

YAMAHA



**PARTS
CATALOGUE**

AG200E (3GX6)

OCEANIA

YAMAHA
GENUINE
Parts & Accessories

| 33GX-700E1

A2

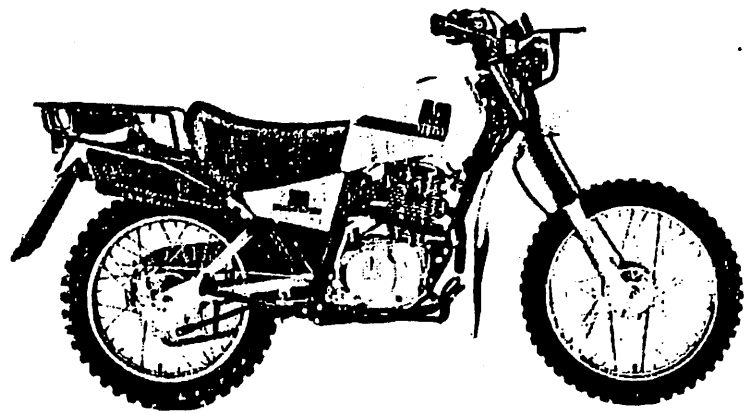

A3

FOREWORD

This Parts Catalogue is related to the parts in use for the Yamaha AG200E(3GX6).
When you are ordering replacement parts for the AG200E(3GX6), refer to this Parts Catalogue and quote both part numbers and part names correctly.

1. Modifications or additions which have been made after issue of the Parts Catalogue will be announced in the Yamaha Parts News.
It is advisable that according to the Yamaha Parts News you make necessary corrections to the Parts Catalogue on hand to keep it up-to-date.

2. Abbreviations

The following abbreviations are used in this Parts Catalogue.

- U.R. Use size (thickness) and/or number as required.
- U.N. Use as many as you need.
- A.P. Alternate Parts
- L.M. Local Made
- F# Frame No. (Applicable machine No.)

3. The parts marked with (-) in the parts number column of this Catalogue are not supplied with by Yamaha, those have to be found locally.
4. Parts, which are to be supplied in the form of assemblies, are listed with an indentation of one letter's space, and a dot (.) is put against the name of each part.

EXAMPLE CARBURETOR ASS'Y
 .JET, pilot
 .NOZZLE, main

5. Indication of No. of constituent parts for assembly

The numeral appearing to the right of each constituent part under the description indicates the quantity of such parts for each individual assembly unit.

EXAMPLE

Part No.	Description	Q'ty	Remarks
2F5-83310-60	FRONT FLASHER LIGHT ASS'Y	2	
115-83311-60	. BULB (6V-18W)	1	
1M1-83309-60	. REFLECTOR	1	

6. Initial Serial No. and Color Code

(A) Frame Serial No.	3GX-018101 and following
(B) Engine Serial No.	3GX-018101 and following

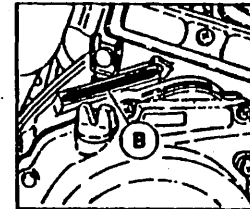
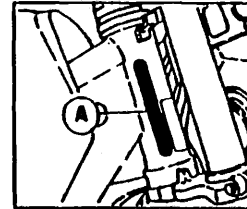

Color Code	Color Name	Abbreviate
00TL	CERAMIC IVORY	CR1

7. Applicable colors of graphics are represented in the "Remarks" column by the letter(s) appropriately picked out of the full word(s) showing such colors.

EXAMPLE

Part No.	Description	Q'ty	Remarks
2N4-24110-00-X5	FUEL TANK COMP.	1	MAXIM RED
3J1-24240-10	. GRAPHIC, fuel tank set	1	for MXR

CONTENTS

ENGINE

Cylinder Head	B2
Cylinder	B3
Crankshaft, Piston	B4 ~ B5
Valve	B6
Camshaft, Chain	B7
Oil Pump	B8
Intake	B9
Carburetor	B10 ~ B11
Exhaust	B12
Crankcase	B13
Crankcase Cover 1	B14
Starter	B15 ~ C2
Clutch	C3 ~ C4
Transmission	C5
Shift Cam. Fork	C6
Shift Shaft	C7

CHASSIS

Frame	C8
Fender	C9
Side Cover	C10
Rear Arm	C11 ~ C12
Rear Suspension	C13
Steering	C14
Front Fork	C15 ~ D2
Fuel Tank	D3
Seat	D4
Front Wheel	D5 ~ D6
Rear Wheel	D7 ~ D8

Steering Handle, Cable	D9
Stand, Footrest	D10
Generator	D11
Flasher Light	D12
Meter	D13
Headlight	D14
Taillight	D15
Handle Switch, Lever	E2
Electrical 1	E3

INDEX

Numerical Index	M1 ~ M3
-----------------------	---------

FIG. 1 CYLINDER HEAD

REF. NO.	PART NO.	DESCRIPTION	Q'TY	REMARKS
1	36X-11102-01	CYLINDER HEAD ASSY	1	
2	5H0-11133-10	.GUIDE, intake valve	2	
3	93440-10085	.CIRCLIP	2	
4	90153-06029	.SCREW, hexagon	1	
5	90430-06014	.GASKET	1	
6	1N0-11181-00	GASKET, cylinder head 1	1	
7	99530-14016	PIN, dowel	3	
8	90430-14131	GASKET	1	
9	90105-08195	BOLT, washer based	4	
10	90201-080L7	WASHER, plate	3	
11	91311-08045	BOLT	2	
12	36X-11185-00	COVER, cylinder head side 1	1	
13	93211-05471	O-RING	1	
14	98501-06020	SCREW, pan head	2	
15	5H0-11186-00	COVER, cylinder head side 2	1	
16	36X-11187-00	COVER, cylinder head side 3	1	
17	93210-57634	O-RING	2	
18	91311-06018	BOLT	4	
19	90110-06064	BOLT, hexagon socket head	1	
20	5H0-1111F-00	PLATE	1	
21	97003-06012	BOLT	2	
22	90215-06184	WASHER, lock	1	
23	94701-00157	PLUG, spark (NGK DBEA)	1	UR
	94701-00181	PLUG, spark (MD X24ES-U)	1	UR
24	36X-12292-00	CABLE, decompression	1	
25	36X-12283-00	BRACKET, decompression	1	

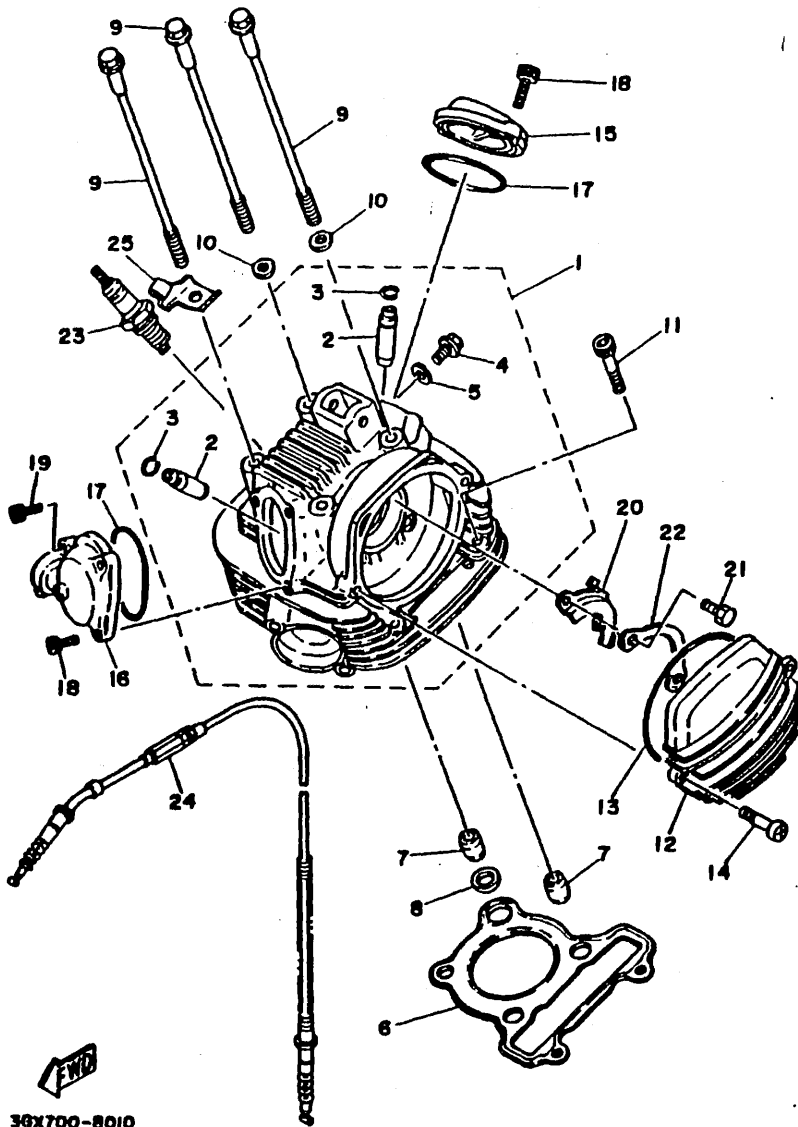

36X700-8010

FIG. 2 CYLINDER

REF. NO.	PART NO.	DESCRIPTION	Q'TY	REMARKS
1	36X-11310-00	CYLINDER	1	
2	93210-72529	O-RING	1	
3	4CS-11351-00	GASKET, cylinder	1	
4	93210-13361	O-RING	1	
5	99530-14016	PIN, dowel	2	
6	91311-06030	BOLT	2	
7	15A-11162-00	ABSORBER 2	2	
8	5H0-11161-00	ABSORBER 1	2	
9	15A-11162-00	ABSORBER 2	1	
10	15A-15441-00	HOLDER, clutch cable	1	

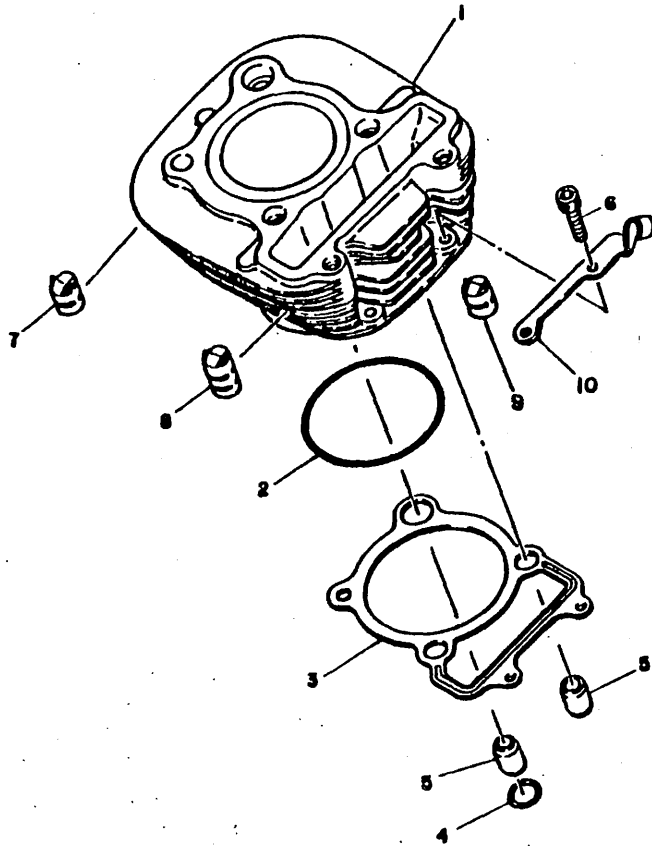

36X700-3020

B3

FIG. 3 CRANKSHAFT, PISTON

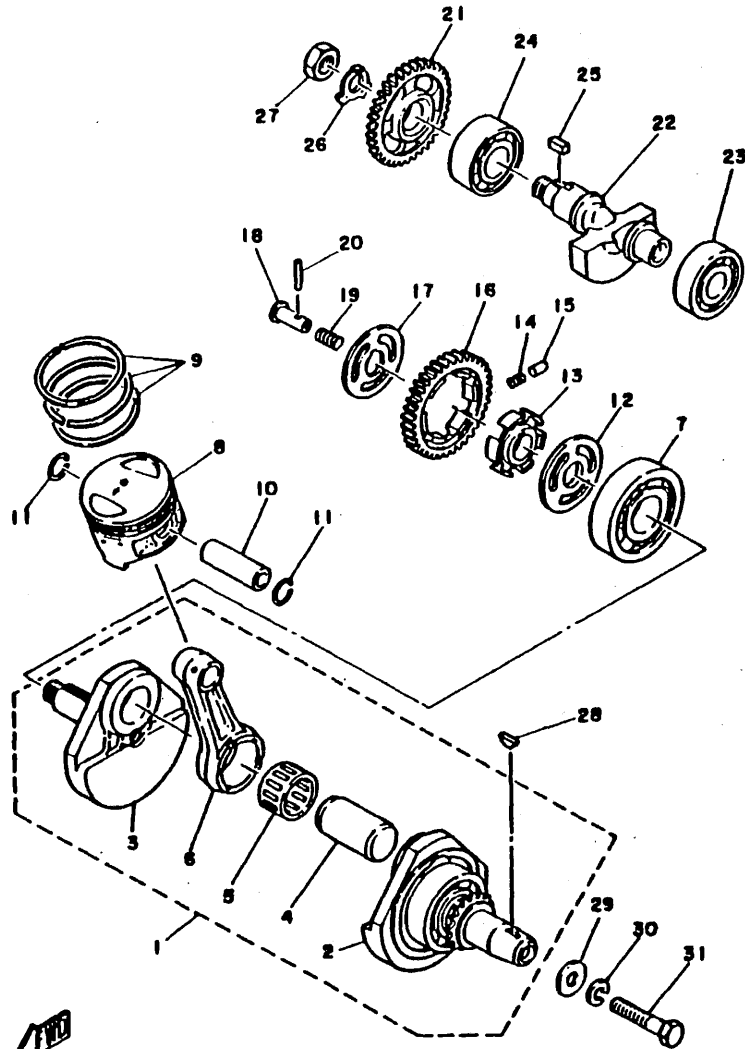

REF. NO.	PART NO.	DESCRIPTION	Q'TY.	REMARKS
1	15A-11400-00	CRANKSHAFT ASSY	1	
2	15A-11412-09	.CRANK 1	1	
3	5H0-11422-00	.CRANK 2	1	
4	5H0-11681-00	.PIN, crank 1	1	
5	93310-530J3	.BEARING, cylindrical	1	
6	15A-11651-00	.ROD, connecting	1	
7	93306-30615	BEARING (86306)	1	
8	36X-11631-00-A0	PISTON (STD)	1	
	36X-11636-00	PISTON (0.50MM O/S)	1	AP
	36X-11638-00	PISTON (1.00MM O/S)	1	AP
9	15A-11603-00	PISTON RING SET (STD)	1	
	15A-11605-00	PISTON RING SET (2ND O/S)	1	AP
	15A-11607-00	PISTON RING SET (4TH O/S)	1	AP
10	58L-11633-00	PIN, piston	1	
11	93450-17044	CIRCLIP	2	
12	90201-201E4	WASHER, plate	1	
13	5H0-11496-00	BOSS, buffer	1	
14	90501-21133	SPRING, compression	6	
15	93605-10090	PIN, dowel	3	
16	5H0-11536-00	GEAR, drive (38T)	1	
17	90214-20023	WASHER, claw	1	
18	90240-07083	PIN, clevis	1	
19	90501-07629	SPRING, compression	1	
20	93602-13177	PIN, dowel	1	
21	5H0-11531-00	GEAR, balance weight (36T)	1	
22	15A-11454-00	WEIGHT 1	1	
23	93306-30427	BEARING	1	
24	93306-30427	BEARING	1	

36X700-3030

B4

FIG. 3 CRANKSHAFT. PISTON

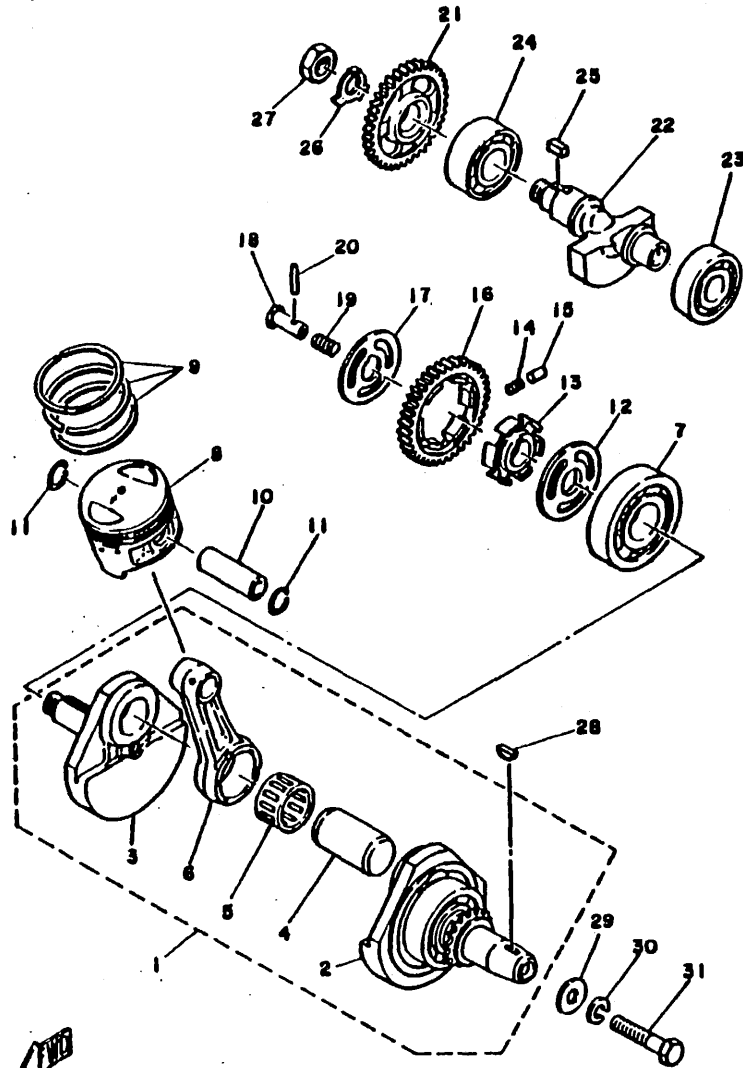

REF. NO.	PART NO.	DESCRIPTION	Q'TY	REMARKS
25	90282-05013	KEY, straight	1	
26	90215-14205	WASHER, lock	1	
27	90170-14284	NUT	1	
28	90280-05013	KEY, woodruff	1	
29	90201-10508	WASHER, plate	1	
30	92901-10100	WASHER, spring	1	
31	90101-10188	BOLT	1	

36X700-3030

B5

FIG. 4 VALVE

REF. NO.	PART NO.	DESCRIPTION	Q'TY	REMARKS
1	5HO-12111-00	VALVE, intake	1	
2	5HO-12121-00	VALVE, exhaust	1	
3	4GO-12116-01	SEAT, valve spring	2	
4	4GO-12113-01	SPRING, valve inner	2	
5	4GO-12114-01	SPRING, valve outer	2	
6	5HO-12119-00	SEAL, valve stem	2	
7	4GO-12117-00	RETAINER, valve spring	2	
8	4GO-12118-00	COTTER, valve	4	
9	36X-12151-00	ARM, valve rocker	2	
10	5HO-12156-00	SHAFT, rocker 2	1	
11	5HO-12146-00	SHAFT, rocker	1	
12	93210-09350	O-RING	1	
13	3Y1-12159-00	SCREW, valve adjusting	2	
14	90170-06128	NUT	2	

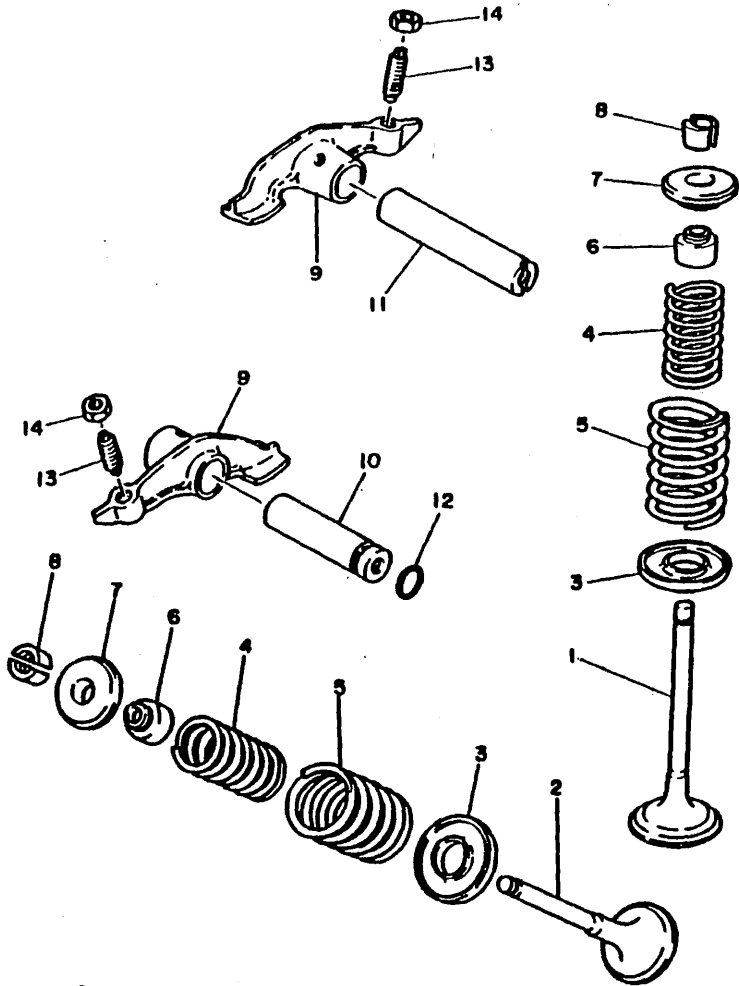

36X700-3040

B6

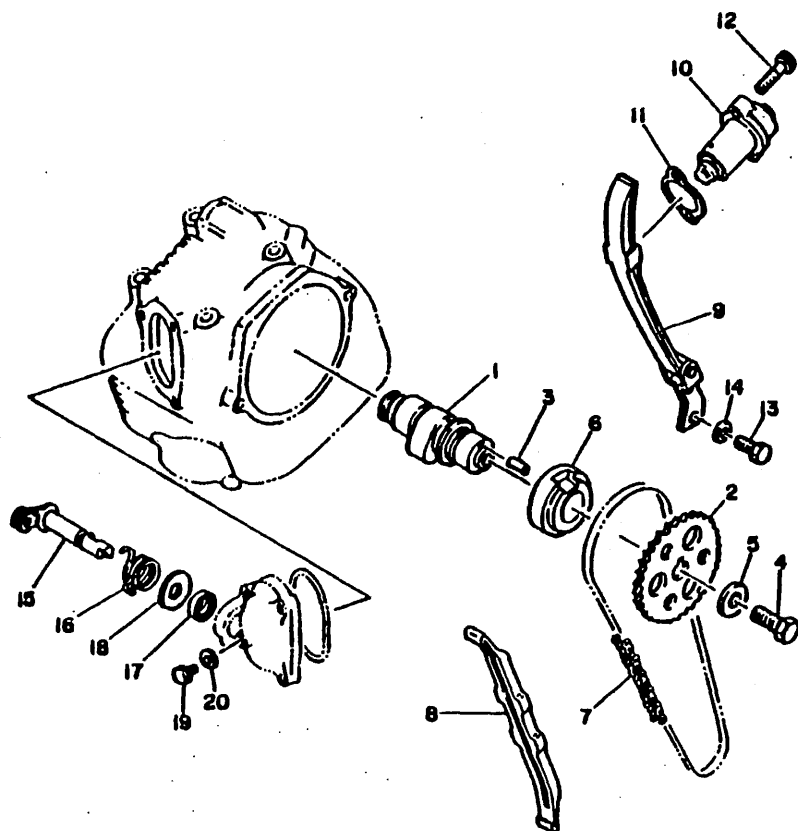

FIG. 5 CAMSHAFT. CHAIN

REF. NO.	PART NO.	DESCRIPTION	Q'TY	REMARKS
1	36X-12171-00	CAMSHAFT 1	1	
2	5H0-12176-00	SPROCKET, cam chain (40T)	1	
3	93604-10011	PIN, dowel	1	
4	90101-10303	BOLT	1	
5	90201-10774	WASHER, plate	1	
6	90387-255F3	COLLAR	1	
7	94580-41104	CHAIN	1	
8	5H0-12231-00	GUIDE, stopper 1	1	
9	5N0-12241-00	GUIDE, stopper 2	1	
10	3GC-12210-10	TENSIONER ASSY, cam chain	1	
11	30X-12213-00	GASKET, tensioner case	1	
12	91311-06025	BOLT	2	
13	97021-06016	BOLT	2	
14	92901-06600	WASHER, plate	2	
15	36X-12288-00	CAM, decompression	1	
16	90508-16428	SPRING, torsion	1	
17	93102-12106	OIL SEAL (SD 12-22-5 HS)	1	
18	90201-12588	WASHER, plate	1	
19	90109-06418	BOLT	1	
20	90430-06014	GASKET	1	



36X700-8050

B7

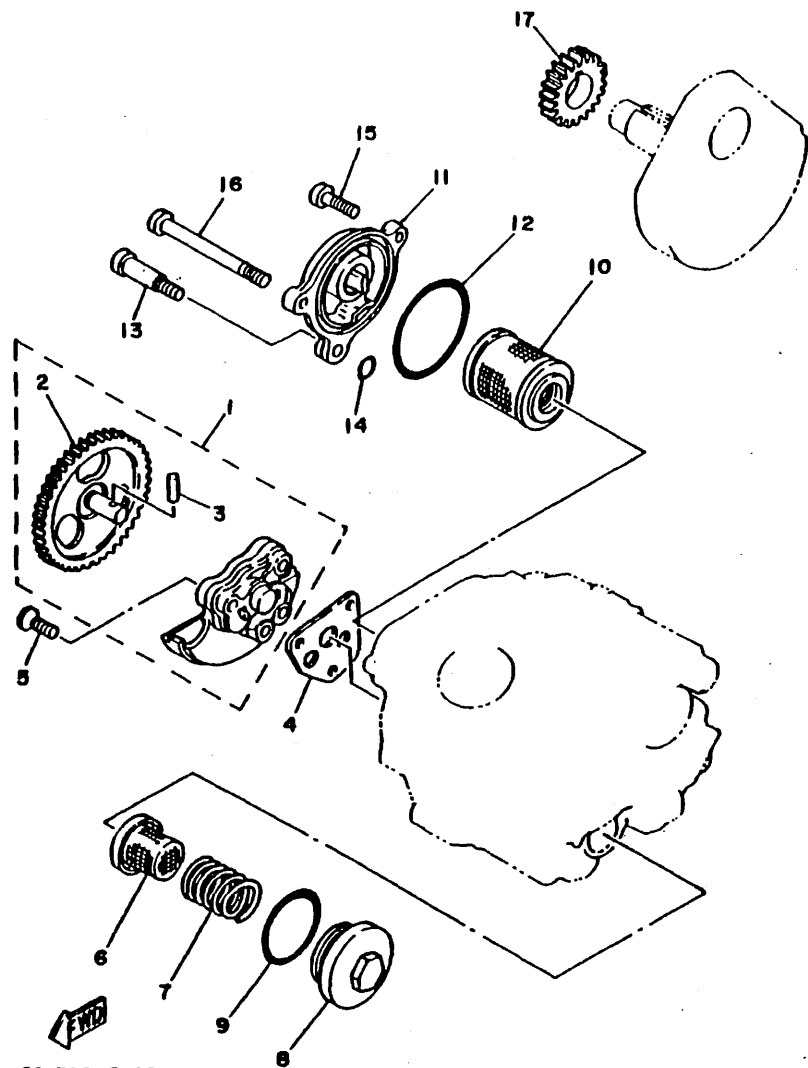
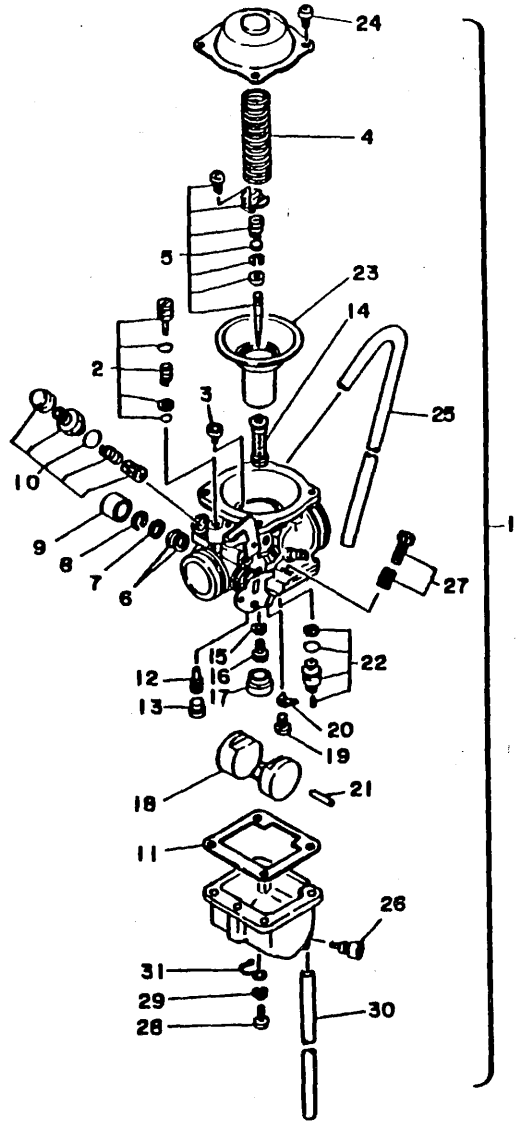

FIG. 6 OIL PUMP

REF. NO.	PART NO.	DESCRIPTION	Q'TY	REMARKS
1	5H0-13300-00	OIL PUMP ASSY	1	
2	5H0-13326-00	.GEAR, pump driven 2 (45T)	1	
3	93603-12030	.PIN, dowel	1	
4	4BE-13329-00	GASKET, pump cover	1	
5	98701-06030	SCREW, flat head	3	
6	51Y-13411-00	STRAINER, oil	1	
7	90501-18576	SPRING, compression	1	
8	5H0-15351-00	PLUG, drain	1	
9	93210-35389	O-RING	1	
10	5H0-13440-00	ELEMENT ASSY, oil cleaner	1	
11	36X-13447-00	COVER, oil element	1	
12	93210-54175	O-RING	1	
13	90109-06755	BOLT	1	
14	93210-07135	O-RING	1	
15	98501-06025	SCREW, pan head	1	
16	98501-06075	SCREW, pan head	1	
17	36X-13324-00	GEAR, pump drive	1	

36X700-3060

FIG. 8 CARBURETOR



REF. NO.	PART NO.	DESCRIPTION	Q'TY	REMARKS
1	36X-14901-00	CARBURETOR ASSY 1	1	
2	36X-14105-00	.PILOT SCREW SET	1	
3	3G2-14231-25	.JET, main (#125)	1	
4	36X-14933-01	.SPRING, diaphragm	1	
5	36X-1490J-00	.NEEDLE SET	1	
6	256-14997-00	.SEAL	2	
7	22F-14126-00	.GASKET	1	
8	812-14137-00	.CLIP	1	
9	36X-14169-00	.CAP	1	
10	36X-1410A-00	.STARTER SET	1	
11	4G0-14984-00	.GASKET, float chamber	1	
12	4G0-14142-35-A0	.JET, pilot (# 35)	1	
13	3F7-14991-00	.SCREW	1	
14	36X-14941-42	.NOZZLE, main	1	
15	137-14153-00	.WASHER, main jet	1	
16	620-14231-74-A0	.JET, main (#117.5)	1	
17	36X-14153-00	.WASHER, main jet	1	
18	4G0-14985-00	.FLOAT	1	
19	98501-04006	.SCREW, pan head	1	
20	36X-14146-00	.PLATE	1	
21	537-14186-00	.PIN, float	1	
22	25G-14107-20	.NEEDLE VALVE SET	1	
23	36X-14940-00	.DIAPHRAGM ASSY	1	
24	98501-05008	.SCREW, pan head	4	
25	36X-14197-00	.PIPE	1	
26	36X-14191-00	.PLUG, drain	1	
27	36X-1490K-00	.STOP SCREW SET	1	
28	98503-04014	.SCREW, pan head	4	

36X700-3080

B10

FIG. 8 CARBURETOR

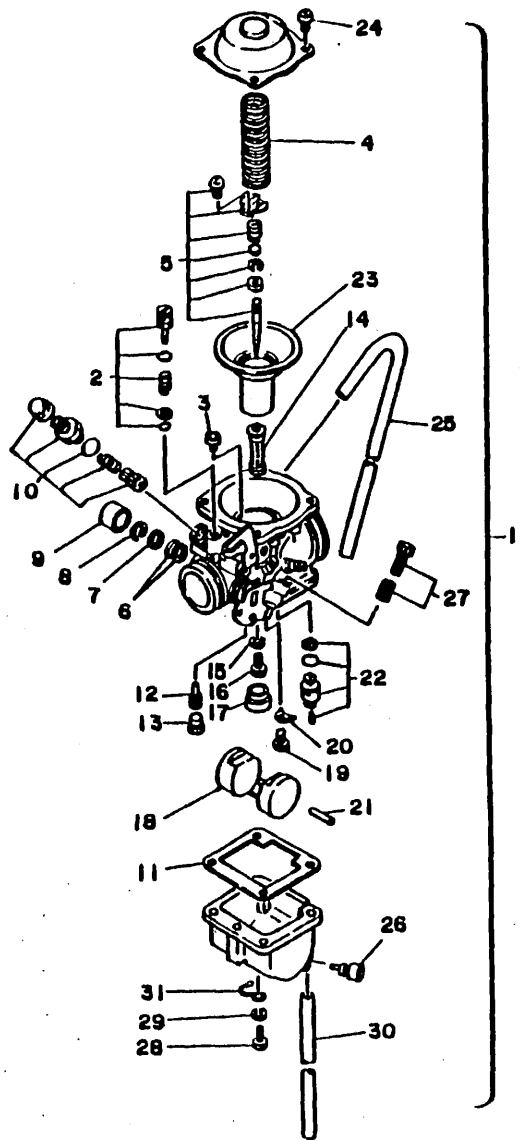

REF. NO.	PART NO.	DESCRIPTION	Q'TY	REMARKS
29	92902-04100	.WASHER, spring	4	
30	21V-14196-00	.PIPE	1	
31	25G-14937-00	.CLIP	1	

36X700-3080

B11

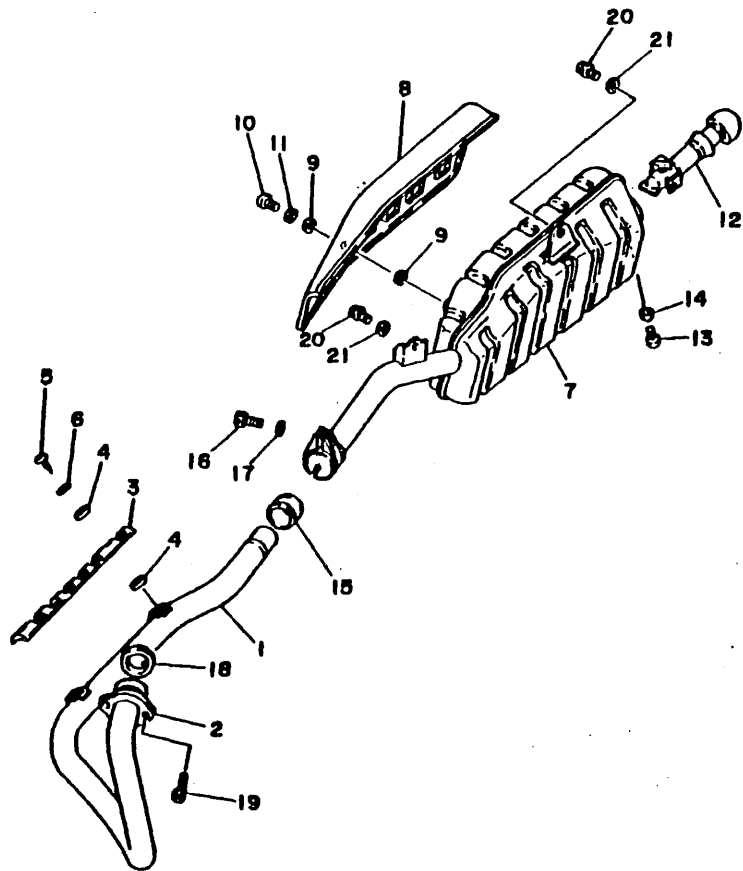

FIG. 9 EXHAUST

REF. NO.	PART NO.	DESCRIPTION	Q'TY	REMARKS
1	36X-14611-01	PIPE, exhaust 1	1	
2	5HO-14612-00	NUT, ring	1	
3	1FE-14628-00	PROTECTOR, exhaust pipe	1	
4	4BD-14766-00	WASHER, protector	4	
5	98906-06010	SCREW, bind	2	
6	90206-06090	WASHER, wave	2	
7	36X-14711-01	MUFFLER 1	1	
8	1FE-14728-00	PROTECTOR, muffler 2	1	
9	4BD-14766-00	WASHER, protector	4	
10	98906-06010	SCREW, bind	2	
11	90206-06090	WASHER, wave	2	
12	36X-14752-01	PIPE, outlet	1	
13	98506-06008	SCREW, pan head	1	
14	92906-06100	WASHER, spring	1	
15	3YF-14714-00	GASKET, muffler	1	
16	91316-08025	BOLT	1	
17	92906-08600	WASHER, plate	1	
18	4BE-14613-00	GASKET, exhaust pipe	1	
19	91316-06020	BOLT	2	
20	90105-08141	BOLT, washer based	2	
21	90201-081H4	WASHER, plate	2	

3GX700-8090

B12

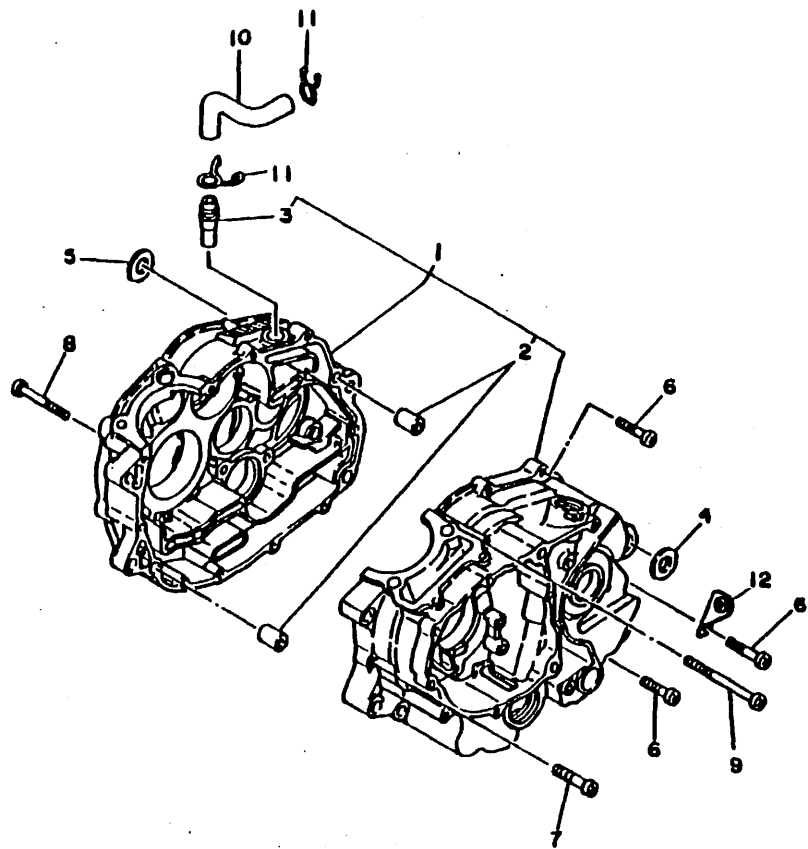

FIG. 10 CRANKCASE

REF. NO.	PART NO.	DESCRIPTION	Q'TY	REMARKS
1	36X-15100-01	CRANKCASE ASSY	1	
2	99510-12016	.PIN, dowel	2	
3	371-11167-01	.PIPE, breather 2	1	
4	90387-125F1	COLLAR	1	
5	90387-125F1	COLLAR	1	
6	98501-06030	SCREW, pan head	7	
7	98501-06040	SCREW, pan head	2	
8	98501-06080	SCREW, pan head	2	
9	98501-06085	SCREW, pan head	1	
10	36X-11166-00	PIPE, breather 1	1	
11	90467-14015	CLIP	2	
12	90465-08200	CLAMP	1	

3GX700-8100

B13

FIG. 11 CRANKCASE COVER 1

REF. NO.	PART NO.	DESCRIPTION	Q'TY	REMARKS
1	36X-15411-00	COVER, crankcase 1	1	
2	15A-15451-01	GASKET, crankcase cover 1	1	
3	99510-12016	PIN, dowel	2	
4	98501-06025	SCREW, pan head	6	
5	98501-06035	SCREW, pan head	2	
6	90340-14068	PLUG, straight screw	1	
7	93210-14369	O-RING	1	
8	90340-32069	PLUG, straight screw	1	
9	93210-32172	O-RING	1	
10	90465-08188	CLAMP	1	
11	98501-06010	SCREW, pan head	1	
12	90465-18187	CLAMP	1	
13	36X-15421-00	COVER, crankcase 2	1	
14	98501-06025	SCREW, pan head	2	
15	36X-15431-01	COVER, crankcase 3	1	
16	48E-15462-00	GASKET, crankcase cover 3	1	
17	99510-12016	PIN, dowel	2	
18	98501-06025	SCREW, pan head	5	
19	98501-06035	SCREW, pan head	3	
20	98503-06045	SCREW, pan head	2	
21	1RG-15363-00	PLUG, oil	1	
22	93210-19123	O-RING	1	
23	3Y1-15361-00	GAUGE, level	1	
24	36X-15378-00	HOLDER	1	

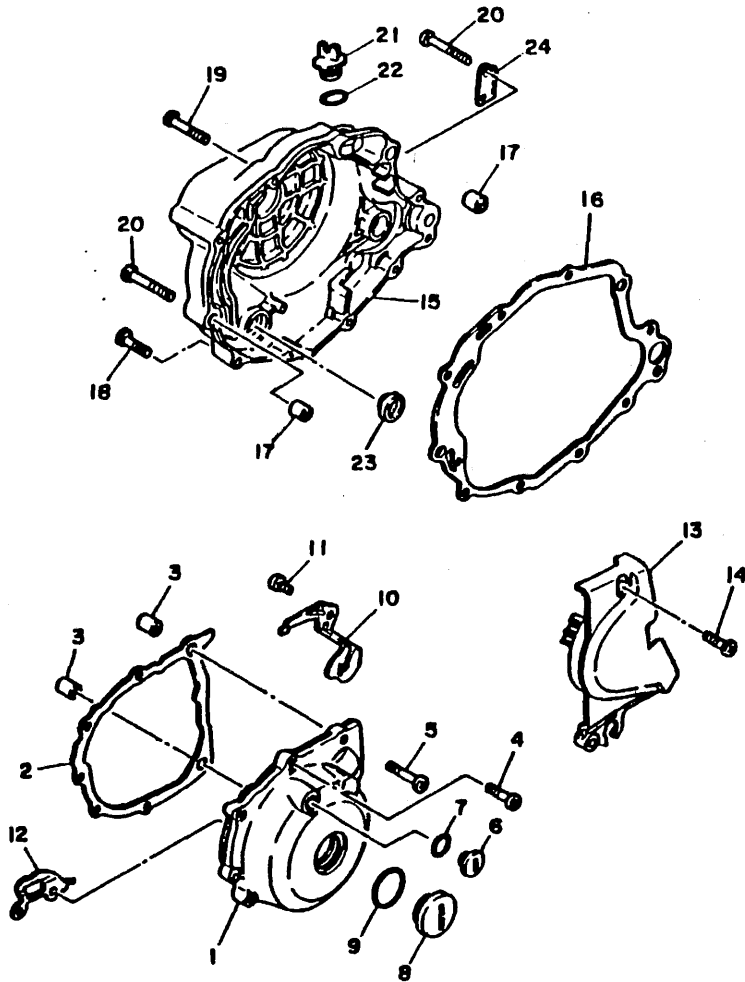

36X700-310

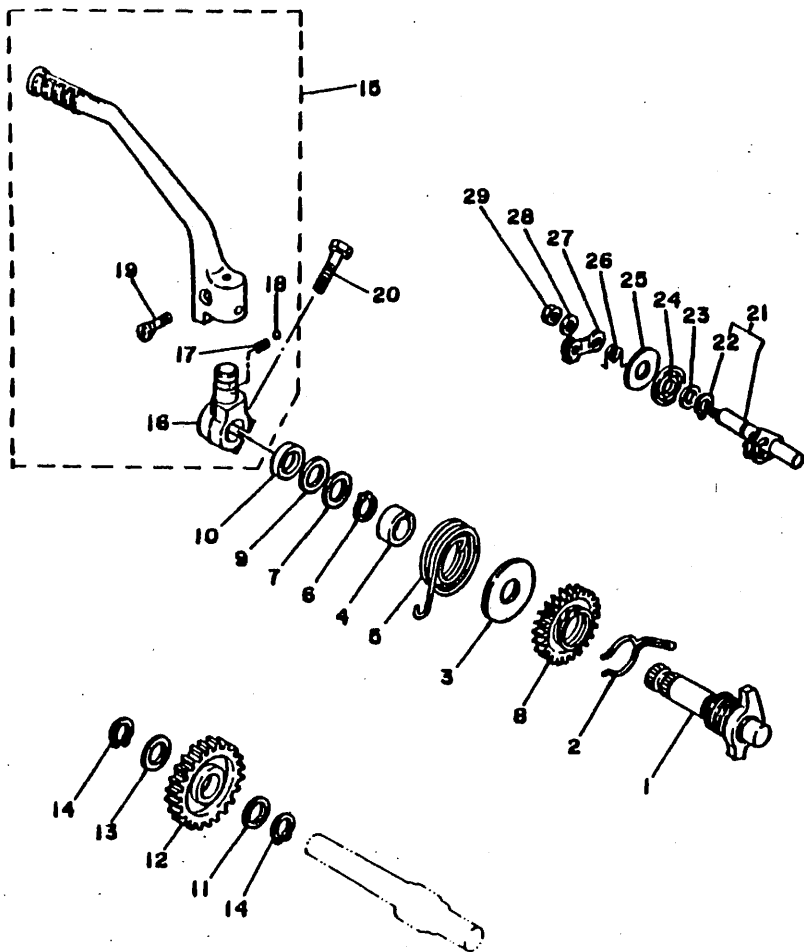

FIG. 12 STARTER

REF. NO.	PART NO.	DESCRIPTION	Q'TY	REMARKS
1	36X-15660-01	KICK AXLE ASSY	1	
2	90468-26122	CLIP	1	
3	401-15676-00	COVER, spring	1	
4	15A-15666-00	SPACER	1	
5	90508-26538	SPRING, torston	1	
6	99009-17400	CIRCLIP	1	
7	90201-175F6	WASHER, plate	1	
8	36X-15641-00	GEAR, kick	1	
9	90209-17226	WASHER	1	
10	93102-17263	OIL SEAL	1	
11	90201-173F4	WASHER, plate	1	
12	15A-15651-01	GEAR, kick idle (2BT)	1	
13	90214-17028	WASHER, claw	1	
14	99009-17400	CIRCLIP	2	
15	36X-15620-01	KICK CRANK ASSY	1	
16	36X-15621-01	.BOSS, kick crank	1	
17	90501-12081	.SPRING, compression	1	
18	93507-32031	.BALL	1	
19	90157-06048	.SCREW, pan head	1	
20	97021-08030	BOLT	1	
21	36X-1561A-00	DECOMP. LEVER ASSY	1	
22	99009-10400	.CIRCLIP	1	
23	90201-10644	WASHER, plate	1	
24	93102-10207	OIL SEAL (SD 10-21-5 HS)	1	
25	90201-105J4	WASHER, plate	1	
26	90508-14620	SPRING, torston	1	
27	36X-15616-00	LEVER, cable	1	
28	92901-06600	WASHER, plate	1	

36X700-3120

B15

FIG. 12 STARTER

REF. NO.	PART NO.	DESCRIPTION	Q'TY	REMARKS
29	95311-06700	NUT	1	

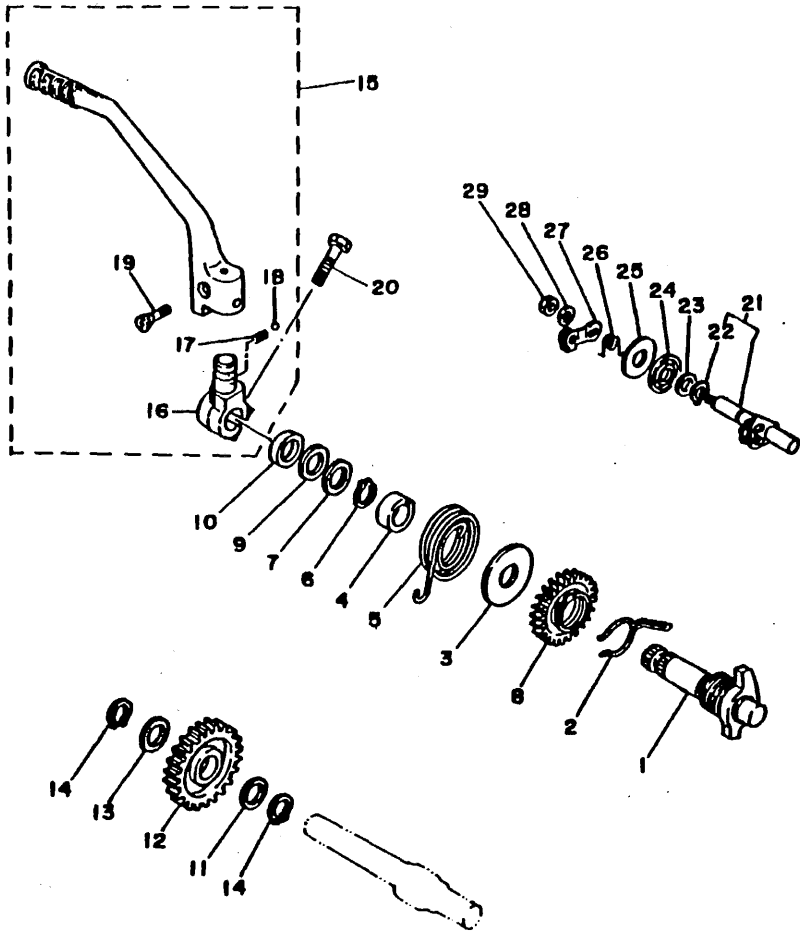

36X700-3120

C2

FIG. 13 CLUTCH

REF. NO.	PART NO.	DESCRIPTION	Q'TY	REMARKS
1	36X-16111-00	GEAR, primary drive	1	
2	90282-05043	KEY, straight	1	
3	90215-14205	WASHER, lock	1	
4	90170-14284	NUT	1	
5	36X-16150-00	PRIMARY DRIVEN GEAR COMP.	1	
6	5H0-16154-00	PLATE, thrust 1	1	
7	36X-16371-00	BOSS, clutch	1	
8	537-16321-00	PLATE, friction	4	
9	137-16324-00	PLATE, clutch 1	4	
10	5H0-16351-00	PLATE, pressure 1	1	
11	90501-23700	SPRING, compression	4	
12	90159-05011	SCREW, with washer	4	
13	30X-16358-00	PLATE, push	1	
14	5H0-16356-01	ROD, push 1	1	
15	93210-48364	O-RING	1	
16	92901-06200	WASHER, plain	1	
17	95303-06600	NUT	1	
18	36X-16321-00	PLATE, friction	1	
19	36X-16383-00	SPRING, clutch boss	1	
20	90215-14224	WASHER, lock	1	
21	90170-14284	NUT	1	
22	15A-16380-00	PUSH LEVER ASSY	1	
23	90430-08119	GASKET	1	
24	90149-08067	SCREW	1	
25	90508-18537	SPRING, torsion	1	
26	5H0-16357-00	ROD, push 2	1	
27	93505-16006	BALL	1	
28	90386-14103	BUSH	1	

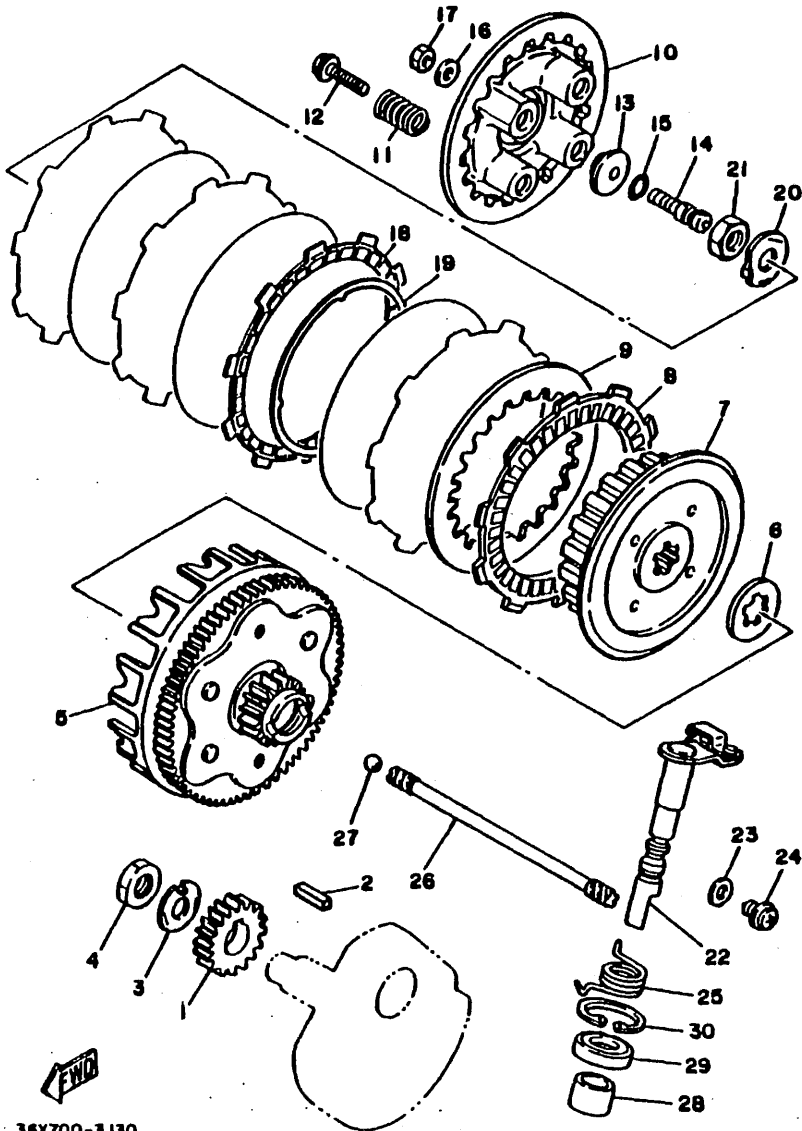

36X700-3130

C3

FIG. 13 CLUTCH

REF. NO.	PART NO.	DESCRIPTION	Q'TY	REMARKS
29	93102-14209	OIL SEAL	1	
30	93420-28055	CIRCLIP	1	

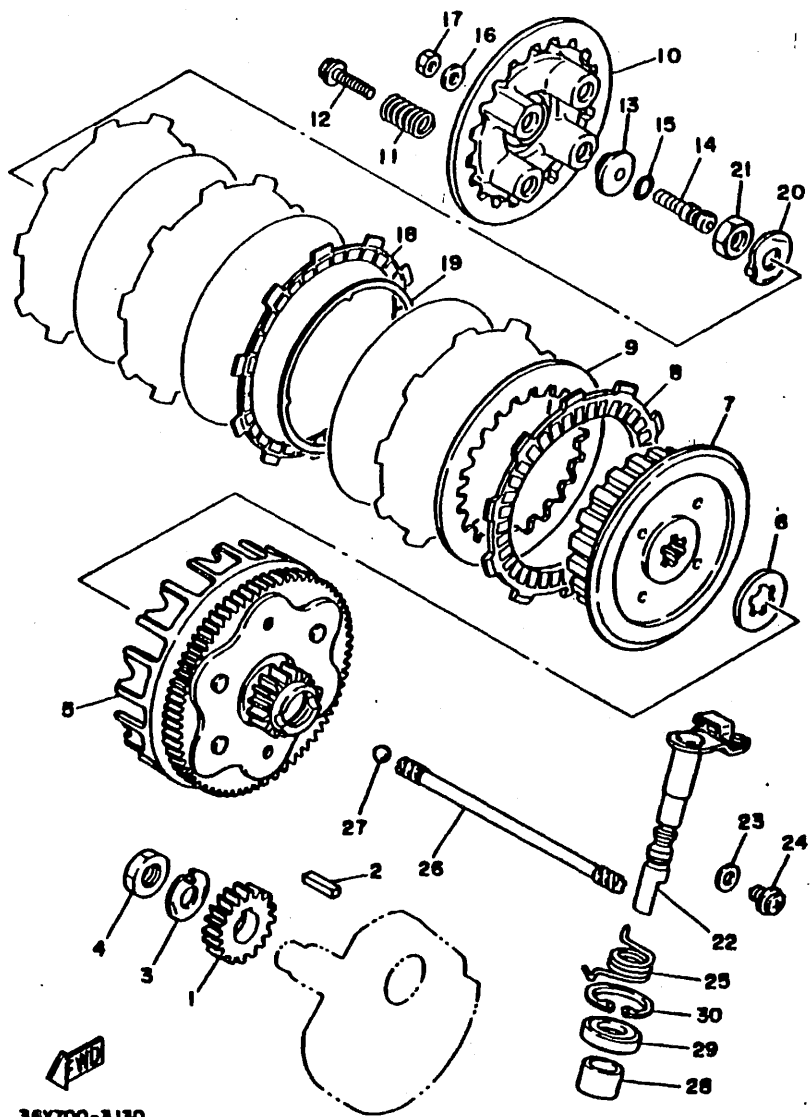

36X700-3130

C4

FIG. 14 TRANSMISSION

REF. NO.	PART NO.	DESCRIPTION	Q'TY	REMARKS
1	36X-17411-00	AXLE, main	1	
2	36X-17141-01	GEAR, 4th pinion	1	
3	90209-16209	WASHER	1	
4	93410-20038	CIRCLIP	1	
5	24W-17131-00	GEAR, 3rd pinion (21T)	1	
6	36X-17151-00	GEAR, 5th pinion	1	
7	24W-17121-00	GEAR, 2nd pinion (15T)	1	
8	93306-20401	BEARING (B6204)	1	
9	93101-15101	OIL SEAL	1	
10	93306-20201	BEARING (B6202)	1	
11	15A-17402-01	DRIVE AXLE ASSY	1	
12	36X-17221-00	GEAR, 2nd wheel	1	
13	36X-17251-00	GEAR, 5th wheel	1	
14	24W-17231-00	GEAR, 3rd wheel (30T)	1	
15	36X-17241-01	GEAR, 4th wheel	1	
16	90209-18208	WASHER	1	
17	93410-22039	CIRCLIP	1	
18	36X-17211-00	GEAR, 1st wheel	1	
19	90201-17257	WASHER, plate	1	
20	99009-17400	CIRCLIP	1	
21	90201-203E7	WASHER, plate	1	
22	93306-30424	BEARING (B6304A3)	1	
23	93102-20242	OIL SEAL	1	
24	93306-20332	BEARING	1	
25	93822-14043	SPROCKET, drive 14t (5N01746141)	1	
26	5H0-17456-00	HOLDER, sprocket	1	
27	97021-06010	BOLT	2	

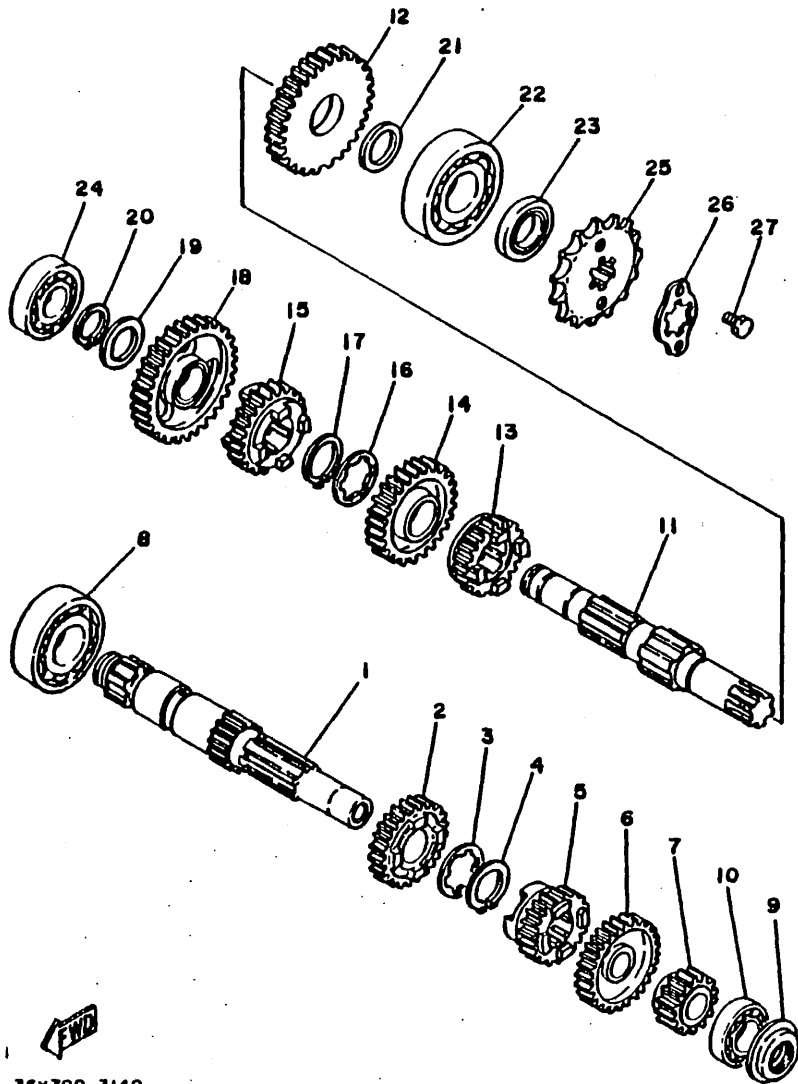

← FWD
36X700-3140

C5

FIG. 15 SHIFT CAM. FORK

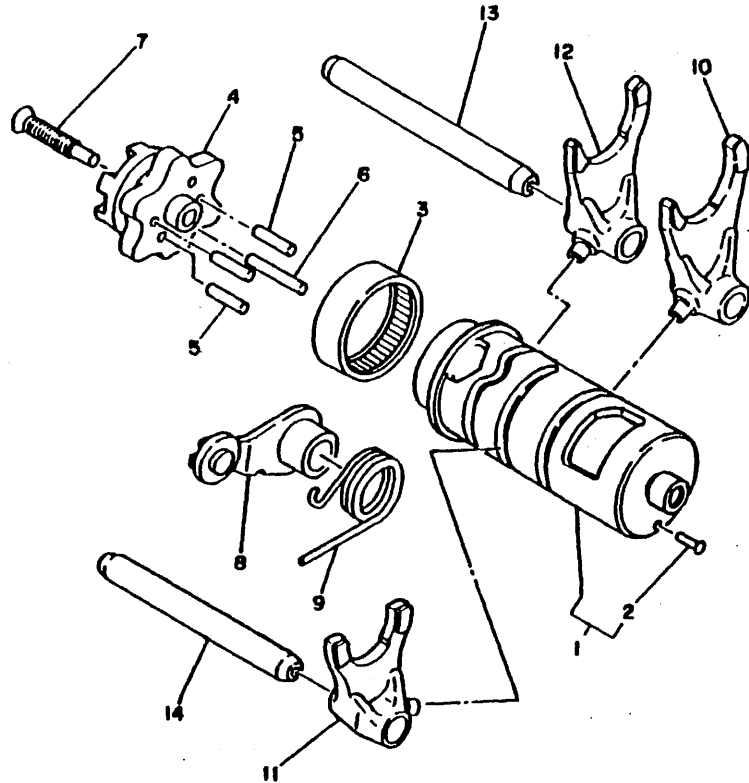

REF. NO.	PART NO.	DESCRIPTION	Q'TY	REMARKS
1	36X-18540-00	SHIFT CAM ASSY	1	
2	136-18542-00	.POINT, neutral	1	
3	93315-23607	BEARING, cylindrical	1	
4	5H0-18185-01	SEGMENT	1	
5	93604-16092	PIN, dowel	4	
6	93604-20156	PIN, dowel	1	
7	90151-06013	SCREW, countersunk	1	
8	4G0-18140-00	STOPPER LEVER ASSY	1	
9	90508-26539	SPRING, torsion	1	
10	36X-18513-00	FORK, shift 3	1	
11	5H0-18511-00	FORK, shift 1	1	
12	5H0-18512-00	FORK, shift 2	1	
13	5H0-18531-00	BAR, shift fork guide 1	1	
14	40W-18535-00	BAR, shift fork guide 2	1	



38X700-3190

FIG. 16 SHIFT SHAFT

REF. NO.	PART NO.	DESCRIPTION	Q'TY	REMARKS
1	5H0-18120-02	SHIFT LEVER ASSY	1	
2	90506-08227	.SPRING, tension	1	
3	90508-29540	SPRING, torsion	1	
4	99001-10600	CIRCLIP	1	
5	90201-12588	WASHER, plate	2	
6	93608-50158	PIN, dowel	1	
7	93102-12106	OIL SEAL (SD 12-22-5 HS)	1	
8	2W5-18111-00	PEDAL, shift	1	
9	132-18113-01	COVER, shift pedal	1	
10	97011-06020	BOLT	1	

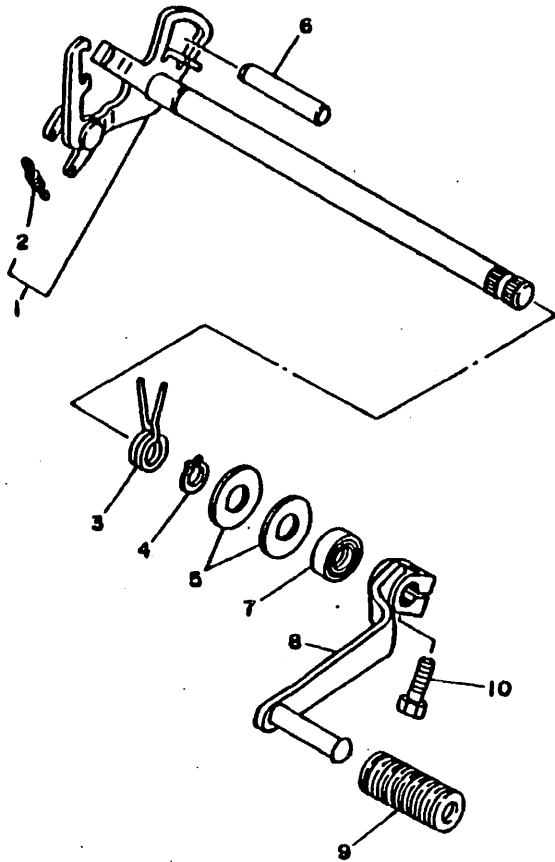

3GX700-8160

C7

FIG. 17 FRAME

REF. NO.	PART NO.	DESCRIPTION	Q'TY	REMARKS
1	36X-21110-00-33	FRAME COMP.	1	YAMAHA BLACK
2	36X-21316-00	STAY, engine 3	1	
3	95811-08065	BOLT, flange	3	
4	95811-08070	BOLT, flange	1	
5	90201-094G1	WASHER, plate	4	
6	90185-08089	NUT, self-locking	4	
7	36X-21315-00	STAY, engine 2	1	
8	95812-08050	BOLT, flange	1	
9	90201-094G1	WASHER, plate	1	
10	90185-08089	NUT, self-locking	1	
11	90105-08155	BOLT, washer based	2	
12	95811-08120	BOLT, flange	1	
13	90201-094G1	WASHER, plate	1	
14	90185-08089	NUT, self-locking	1	
15	36X-21471-00	PROTECTOR, engine	1	
16	36X-21485-00	DAMPER, rubber 1	2	
17	36X-21287-00	BRACKET, regulator	1	
18	97001-06012	BOLT	1	
19	92990-06100	WASHER, spring	1	
20	90480-14229	GROMMET	1	

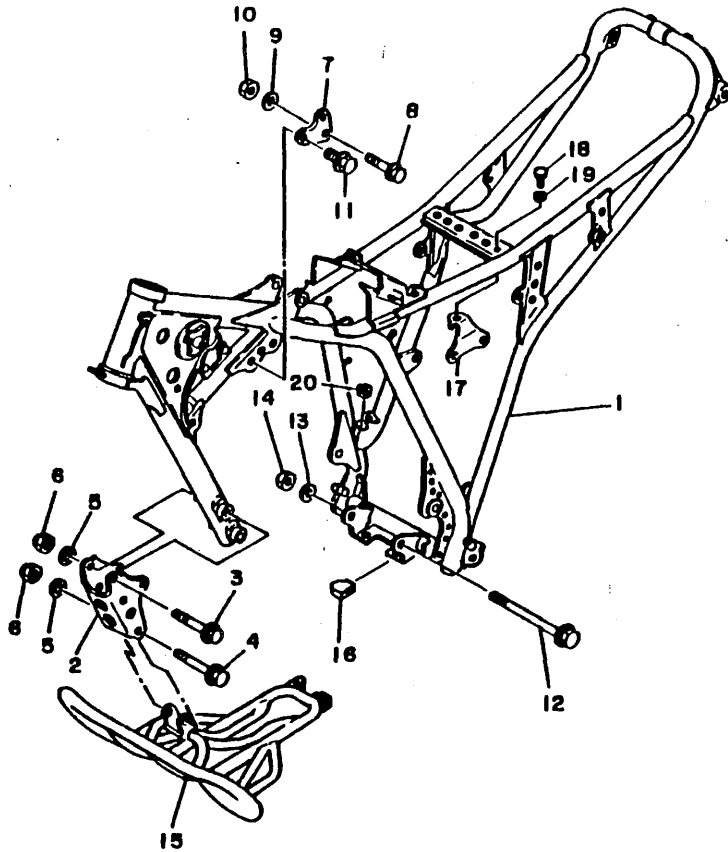

36X700-3171

FIG. 18 FENDER

REF. NO.	PART NO.	DESCRIPTION	Q'TY	REMARKS
1	36X-21511-10	FENDER, front	1	BEIGE
2	90387-062V8	COLLAR	4	
3	90119-06063	BOLT, with washer	4	
4	36X-21521-00	FLAP, front fender	1	
5	36X-21522-00	BAND, flap	1	
6	90159-06085	SCREW, with washer	2	
7	95303-06700	NUT	2	
8	90201-065F3	WASHER, plate	2	
9	36X-21611-10	FENDER, rear	1	BEIGE
10	90119-06097	BOLT, with washer	2	
11	36X-21621-00	FLAP	1	
12	36X-21622-00	BAND, flap	1	
13	36X-21629-00	GUARD, mud	1	
14	90119-06063	BOLT, with washer	2	
15	90464-16021	CLAMP	1	

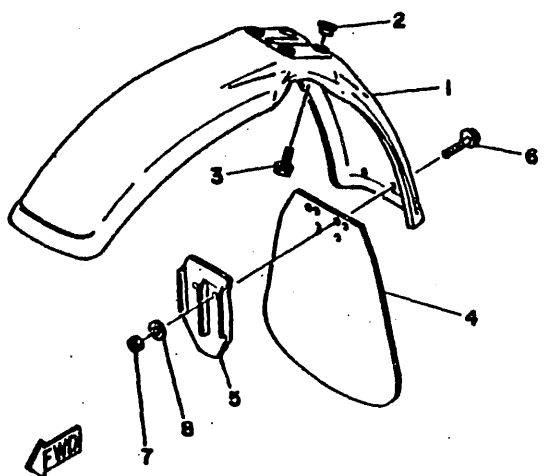
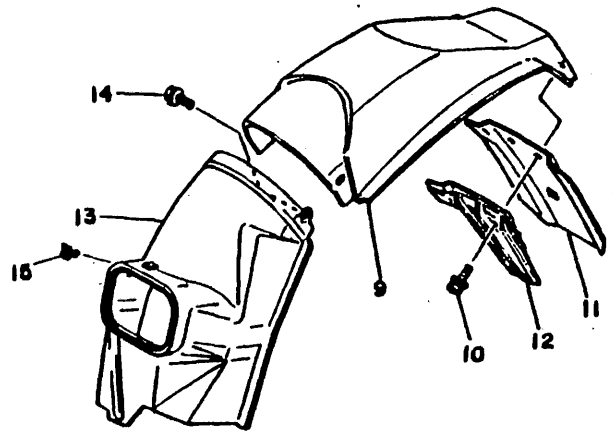

36X700-3180

C9

FIG. 19 SIDE COVER

REF. NO.	PART NO.	DESCRIPTION	Q'TY	REMARKS
1	36X-21711-10	COVER, side 1	1	BEIGE
2	36X-21721-10	COVER, side 2	1	BEIGE
3	90480-12320	GROMMET	3	
4	3H7-21746-00	DAMPER	5	
5	90480-01141	GROMMET	1	
6	36X-2172A-00	PANEL 1	1	
7	92501-06012	SCREW, pan head	2	
8	92990-06600	WASHER, plate	2	
9	36X-21761-20	EMBLEM 1	2	
10	36X-2177F-00	COVER	1	

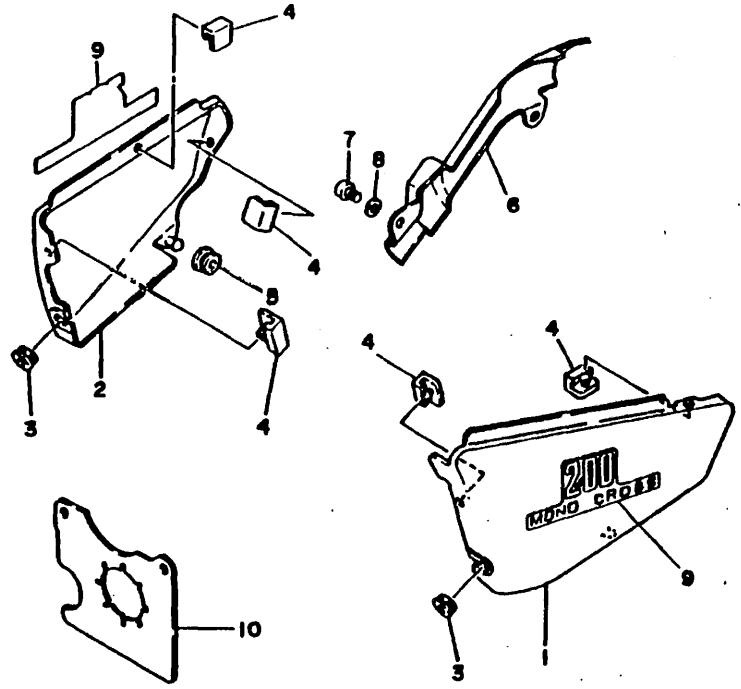

36X700-3191

C10

FIG. 20 REAR ARM

REF. NO.	PART NO.	DESCRIPTION	Q'TY	REMARKS
1	36X-22110-00-35	REAR ARM CO:HP.	1	SILVER
2	15A-22123-00	BUSH 1	2	
3	90386-18028	BUSH	1	
4	93700-06004	NIPPLE, grease	1	
5	93700-06009	NIPPLE, grease	1	
6	36X-22126-00	COLLAR, distance	1	
7	36X-22126-10	COLLAR, distance	1	
8	401-22128-01	SEAL, guard	3	
9	93109-18020	OIL SEAL	1	
10	36X-22141-01	SHAFT, pivot	1	
11	90185-12072	NUT, self-locking	1	
12	401-22127-00	SHIM	1	UN
13	36X-22310-00-35	CHAIN CASE ASSY	1	SILVER
14	98503-06045	SCREW, pan head	1	
15	92901-06600	WASHER, plate	1	
16	95601-06200	NUT, self-locking	1	
17	98501-06016	SCREW, pan head	2	
18	92990-06100	WASHER, spring	2	
19	92901-06600	WASHER, plate	2	
20	148-22315-00	CAP	1	
21	36X-22358-00	SEAL 1	1	
22	90119-06074	BOLT, with washer	1	
23	36X-22325-00	COVER, dust	1	
24	36X-22324-00	STAY, dust cover	1	
25	98501-05008	SCREW, pan head	2	
26	36X-22323-00	STAY, chain case 3	2	
27	98506-04030	SCREW, pan head	1	
28	36X-22318-00	GUARD, chain	1	

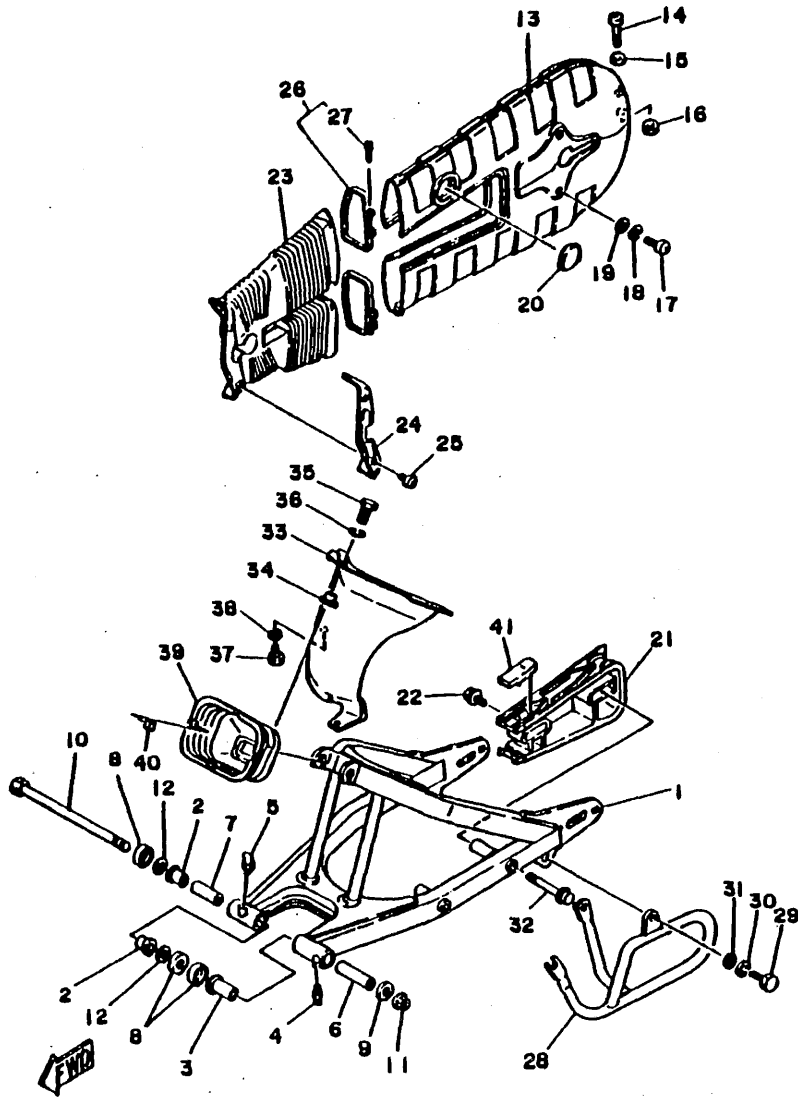

36X4700-1200

C11

FIG. 20 REAR ARM

REF. NO.	PART NO.	DESCRIPTION	Q'TY	REMARKS
29	97313-08012	BOLT	2	
30	92990-08100	WASHER, spring	2	
31	92901-08600	WASHER, plate	2	
32	95811-08090	BOLT, flange	1	
33	36X-22327-00	MUD GUARD 1	1	
34	90387-06681	COLLAR	1	
35	97002-06016	BOLT	1	
36	92990-06100	WASHER, spring	1	
37	97780-50512	SCREW, tapping	2	
38	90201-05032	WASHER, plate	2	
39	36X-22189-00	BOOT, rubber	1	
40	90468-06134	CLIP	4	
41	36X-22151-00	SEAL, guard	1	

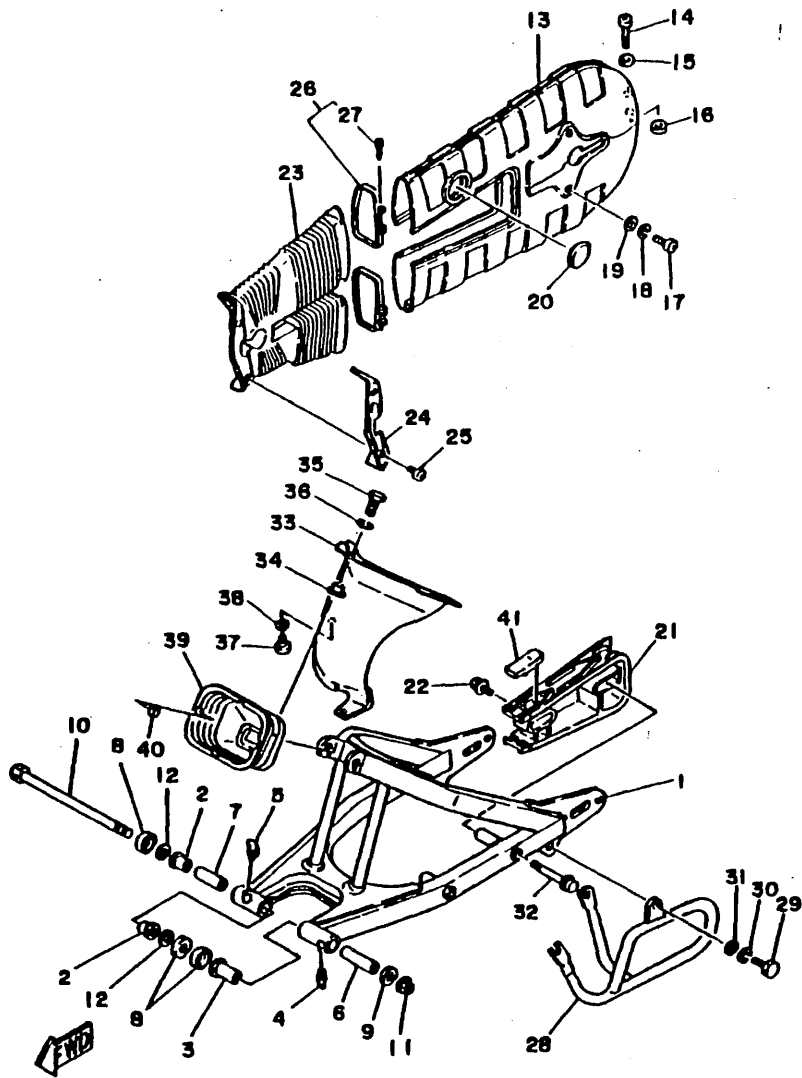

36X4700-1200

FIG. 21 REAR SUSPENSION

REF. NO.	PART NO.	DESCRIPTION	Q'TY	REMARKS
1	36X-22210-10	SHOCK ABSORBER ASSY, rear	1	
2	3R4-22226-00	.BUSH, shock absorber lower	1	
3	90380-12051	.BUSH, solid	2	
4	1YW-22216-00	.BUSH, rear shock absorber	1	
5	90109-10554	BOLT	1	
6	90201-102G9	WASHER, plate	1	
7	95602-10100	NUT, u	1	
8	1W1-22128-00	COVER, thrust l	2	
9	90240-12092	PIN, clevis	1	
10	92990-12600	WASHER, plate	1	
11	91401-30025	PIN, cotter	1	

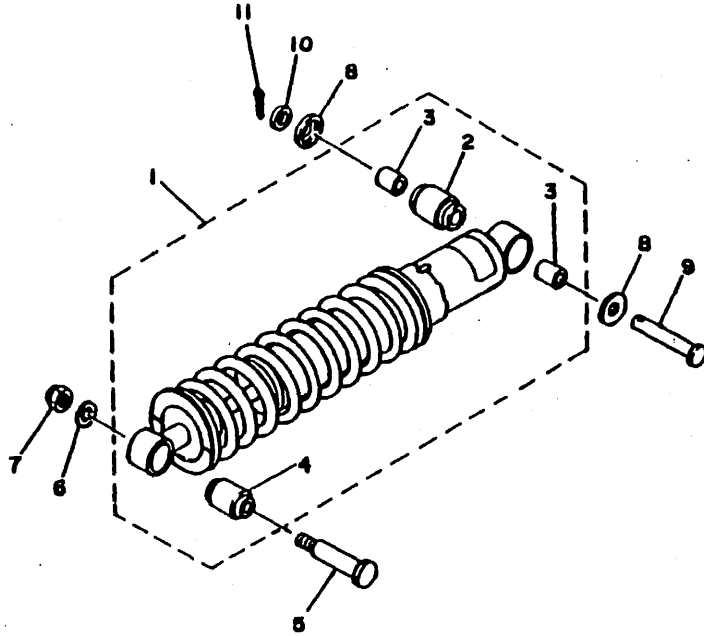

36X700-3210

C13

FIG. 22 STEERING

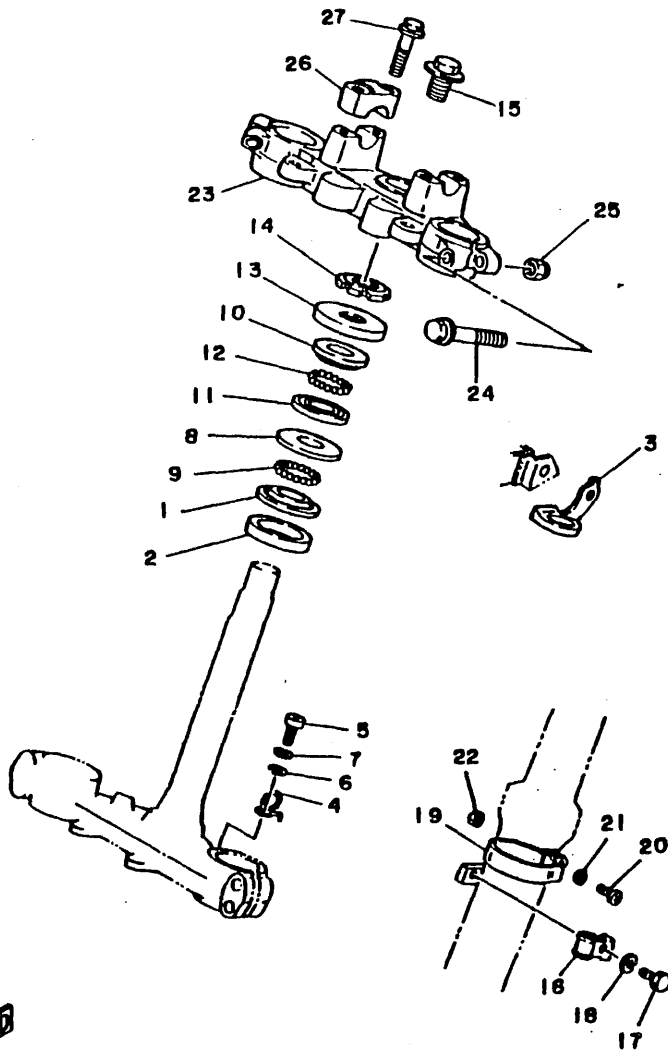

REF. NO.	PART NO.	DESCRIPTION	Q'TY	REMARKS
1	156-23411-00	RACE, ball 1	1	
2	164-23462-00	SEAL, steering	1	
3	36X-23389-00	GUIDE, cable	1	
4	36X-2331E-00	GUIDE, cable	1	
5	92506-06012	SCREW, pan head	1	
6	92906-06600	WASHER, plate	1	
7	92906-06100	WASHER, spring	1	
8	156-23412-00	RACE, ball 2	1	
9	93501-04011	BALL	19	
10	22F-23411-01	RACE, ball 1	1	
11	22F-23412-01	RACE, ball 2	1	
12	93503-16010	BALL	22	
13	36X-23416-00	COVER, ball race 2	1	
14	90179-25033	NUT	1	
15	90105-14102	BOLT, washer based	1	
16	3Y1-23319-00	HOLDER, cable 2	1	
17	97006-06012	BOLT	1	
18	92906-06100	WASHER, spring	1	
19	3R9-23318-00	HOLDER, cable 1	1	
20	98501-05016	SCREW, pan head	1	
21	92901-05600	WASHER, plate	1	
22	95303-05600	NUT	1	
23	36X-23435-00	CROWN, handle	1	
24	95826-10060	BOLT, flange	2	
25	90185-10091	NUT, self-locking	2	
26	1E6-23441-00	HOLDER, handle upper	2	
27	95816-08035	BOLT, flange	4	



30X700-0220

C14

FIG. 23 FRONT FORK

REF. NO.	PART NO.	DESCRIPTION	Q'TY	REMARKS
1	36X-23102-00	FRONT FORK ASSY (L.H)	1	
2	36X-23107-00-35	.OUTER TUBE COMP. (L.H)	1	SILVER
3	4A1-23156-00	..CLIP, oil seal	1	
4	1T3-23145-00	..OIL SEAL	1	
5	4G0-23144-01	..SEAL, dust	1	
6	36X-23110-00	.INNER TUBE COMP.1	1	
7	1W1-23173-L0	.SPINDLE, taper	1	
8	36X-23170-00	.CYLINDER COMP., front fork	1	
9	509-23158-L0	.GASKET	1	
10	278-23181-50	.BOLT, hexagon socket head	1	
11	36X-23191-01	.BOOT	1	
12	36X-23192-00	.BAND	1	
13	4V2-23194-L0	.SCREW, boot band	1	
14	36X-23141-00	.SPRING, front fork	1	
15	583-23142-00	.SEAT, spring upper	1	
16	36X-23118-00	.SPACER	1	
17	1U6-23111-H1	.BOLT, cap	1	
18	240-23114-00	.GASKET	1	
19	122-23129-00	.GASKET, drain plug	1	
20	4H7-23119-00	.PLUG, drain	1	
21	1U6-23168-H1	.CAP, front fork	1	
22	36X-23103-00	FRONT FORK ASSY (R.H)	1	
23	36X-23106-00-35	.OUTER TUBE COMP. (R.H)	1	SILVER
24	4A1-23156-00	..CLIP, oil seal	1	
25	1T3-23145-00	..OIL SEAL	1	
26	4G0-23144-01	..SEAL, dust	1	
27	36X-23110-00	.INNER TUBE COMP. 1	1	
28	1W1-23173-L0	.SPINDLE, taper	1	

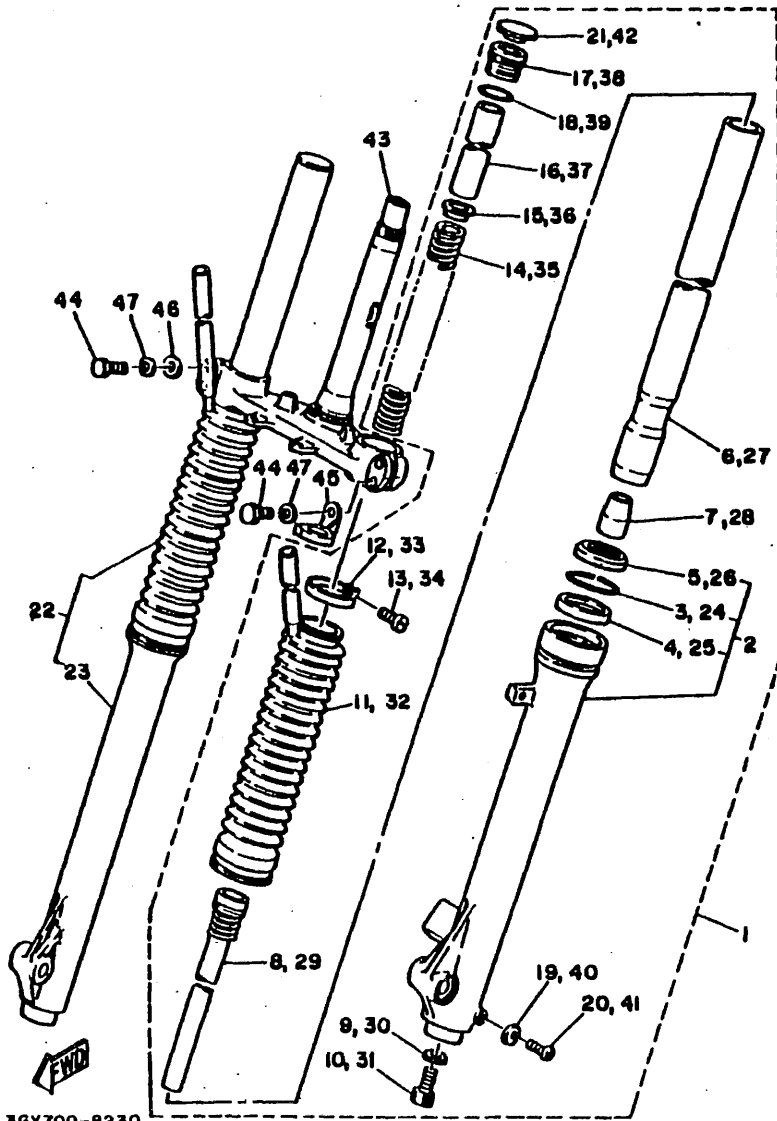

3GX700-8230

C15

FIG. 23 FRONT FORK

REF. NO.	PART NO.	DESCRIPTION	Q'TY	REMARKS
29	36X-23170-00	.CYLINDER COMP., front fork	1	
30	509-23158-L0	.GASKET	1	
31	278-23181-50	.BOLT, hexagon socket head	1	
32	36X-23191-01	.BOOT	1	
33	36X-23192-00	.BAND	1	
34	4V2-23194-L0	.SCREW, boot band	1	
35	36X-23141-00	.SPRING, front fork	1	
36	583-23142-00	.SEAT, spring upper	1	
37	36X-23118-00	.SPACER	1	
38	1U6-23111-M1	.BOLT, cap	1	
39	240-23114-00	.GASKET	1	
40	122-23129-00	.GASKET, drain plug	1	
41	4H7-23119-00	.PLUG, drain	1	
42	1U6-23168-M1	.CAP, front fork	1	
43	36X-23340-00-33	UNDER BRACKET COMP.	1	YAMAHA BLACK
44	36X-23128-00	BOLT, axle holder	4	
45	5Y1-23389-00	GUIDE, cable	1	
46	36X-23392-00	WASHER, special	2	
47	92906-08100	WASHER, spring	4	

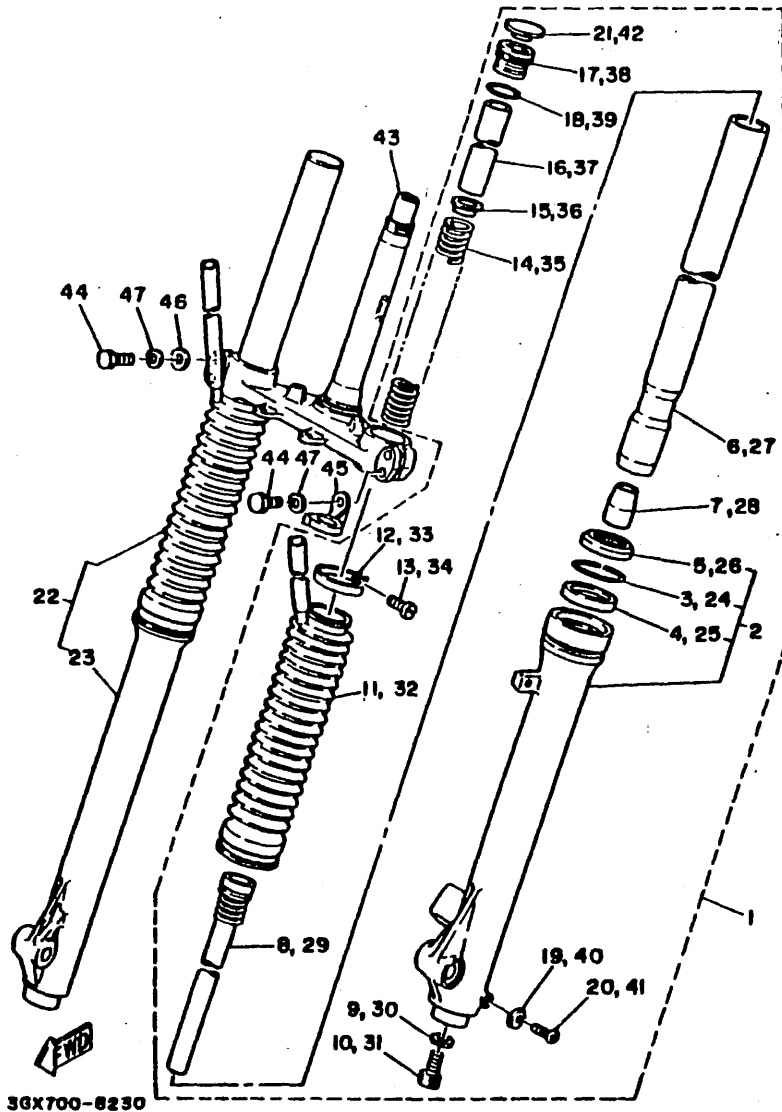

36X700-8230

FIG. 24 FUEL TANK

REF. NO.	PART NO.	DESCRIPTION	Q'TY	REMARKS
1	36X-24110-00-03	FUEL TANK COMP.	1	CERAMIC IVORY
2	3GX-24244-10	.GRAPHIC, fuel tank 1	2	
3	4H7-24181-00	DAMPER, locating 1	2	
4	36X-24182-00	DAMPER, locating 2	1	
5	36X-24186-00	WASHER, special	2	
6	97002-06016	BOLT	2	
7	92990-06100	WASHER, spring	2	
8	15A-24500-03	FUEL COCK ASSY 1	1	
9	3AJ-24523-00	.VALVE	1	
10	3AJ-24534-00	.SEAL, cock	1	
11	4X8-24512-00	.GASKET	1	
12	97801-03008	.SCREW, pan head	2	
13	90149-06011	SCREW	2	
14	90202-05193	WASHER, plate	2	
15	90445-10638	HOSE	1	
16	90467-09006	CLIP	2	
17	36X-24610-00	CAP ASSY	1	

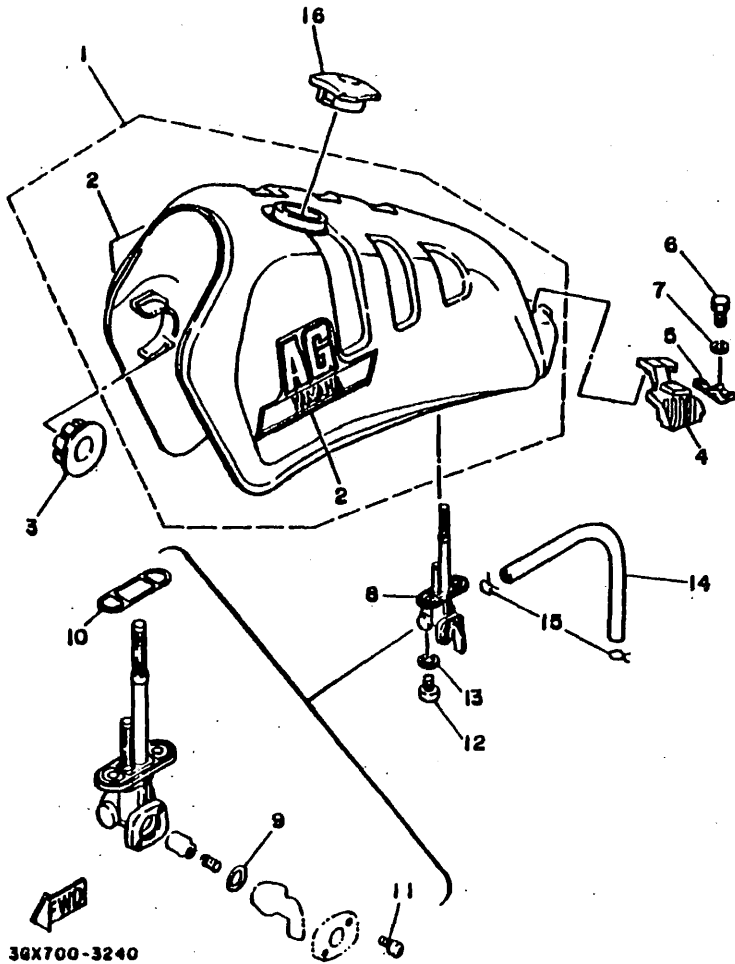

36X700-3240

D3

FIG. 25 SEAT

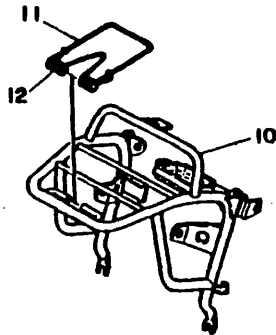
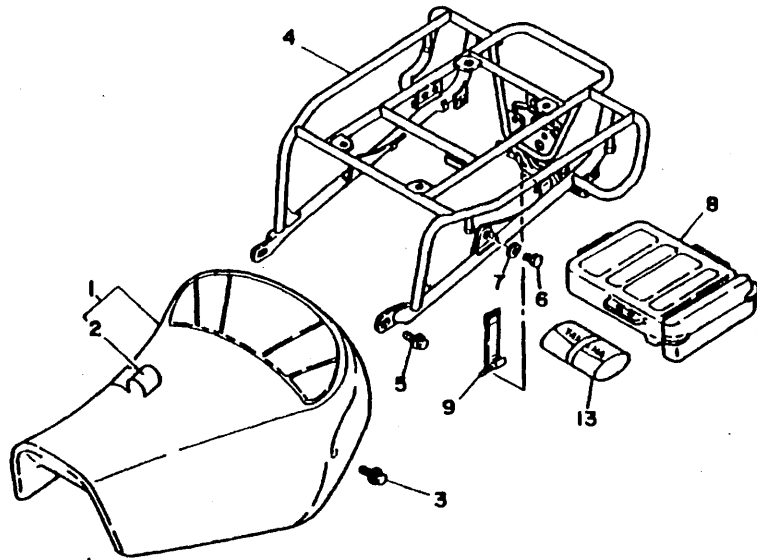

REF. NO.	PART NO.	DESCRIPTION	Q'TY	REMARKS
1	3GX-24710-20	SINGLE SEAT ASSY	1	RED
2	3GX-24711-00	.COVER, single seat	1	RED
3	90119-06061	BOLT, with washer	2	
4	36X-24810-00-98	CARRIER ASSY	1	LOW GLOSS BLACK
5	95816-08012	BOLT, flange	2	
6	90105-08141	BOLT, washer based	1	
7	90201-081H4	WASHER, plate	1	
8	36X-21107-00	TOOL BOX COMP.	1	
9	36X-2811G-00	BAND	1	
10	36X-24860-00-98	FRONT CARRIER ASSY	1	LOW GLOSS BLACK
11	36X-24862-00	CLAMP, carrier	1	
12	36X-24861-00	SPRING, front carrier	1	
13	36X-W2810-00	TOOL KIT	1	



36X700-3250

D4

FIG. 26 FRONT WHEEL

REF. NO.	PART NO.	DESCRIPTION	Q'TY	REMARKS
1	248-25111-00-Y8	HUB, front	1	SILVER
2	93306-30103	BEARING	2	
3	90560-12138	SPACER	1	
4	109-25315-00	FLANGE, spacer	1	
5	93102-18008	OIL SEAL	1	
6	23F-25121-00-35	PLATE, brake shoe	1	SILVER
7	48E-W2536-00	BRAKE SHOE KIT 2	1	
8	90506-15260	SPRING, tension	2	
9	36X-25135-00	GEAR, drive	1	
10	109-25136-00	BUSH	1	
11	36X-25138-00	GEAR, meter	1	
12	93104-07003	OIL SEAL	1	
13	90201-07076	WASHER, plate	1	
14	90201-20269	WASHER, plate	2	
15	183-25149-00	CLUTCH, meter	1	
16	99009-20400	CIRCLIP	1	
17	5H0-25155-00	LEVER, camshaft 1	1	
18	90101-06278	BOLT	1	
19	95303-06600	NUT	1	
20	3V6-25351-00	CAMSHAFT	1	
21	93105-47007	OIL SEAL	1	
22	23F-2533A-00	PLATE, indicator	1	
23	3V6-25104-00	SPOKE SET, front	1	
24	94130-195E9	TIRE (3.00-19)	1	
25	94227-19177	TUBE (2.75-19)	1	DUNLOP
26	94327-19111	BAND, rim (2.75-19)	1	INOUE
27	94416-19263	RIM (1.60-19)	1	
28	353-25381-00	AXLE, wheel	1	

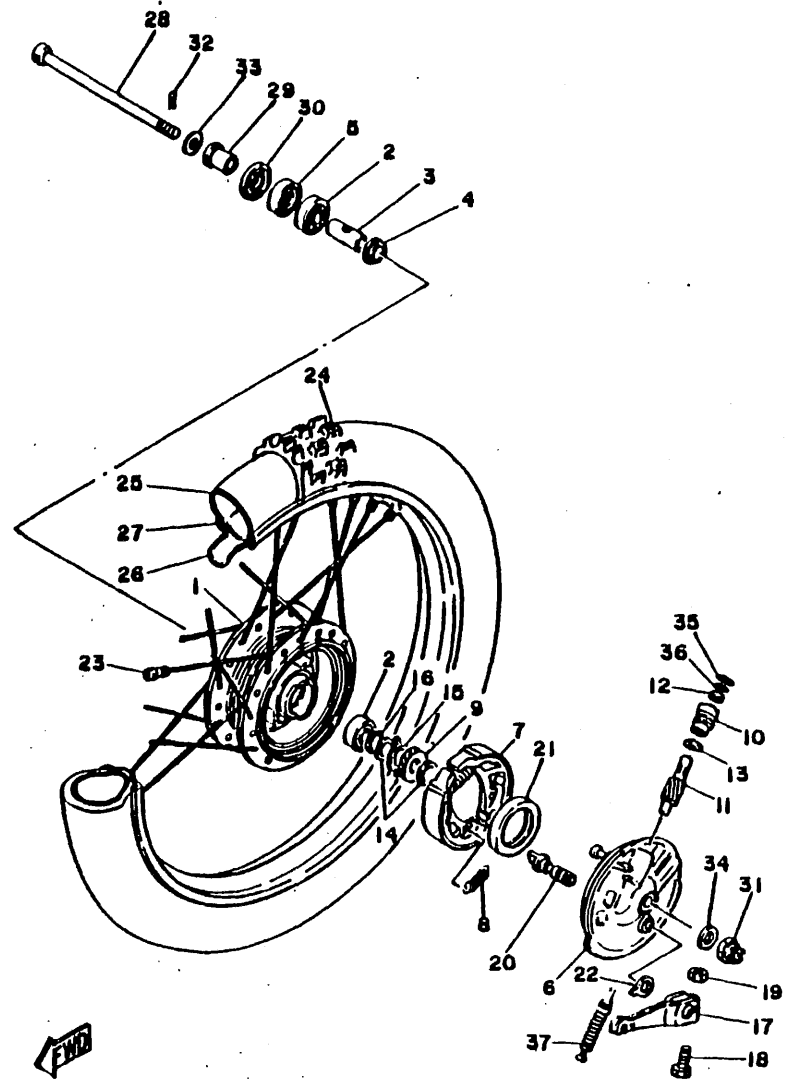

FWD
86X5700-2260

D5

FIG. 26 FRONT WHEEL

REF. NO.	PART NO.	DESCRIPTION	Q'TY	REMARKS
29	90387-12265	COLLAR	1	
30	2K5-25118-00	COVER, hub dust	1	
31	90171-10004	NUT, castle	1	
32	91401-20020	PIN, cotter	1	
33	90201-122A7	WASHER, plate	1	
34	92901-10200	WASHER, plain	1	
35	102-25137-00	RING, stop	1	
36	93210-14104	O-RING	1	
37	90501-12792	SPRING, compression	1	

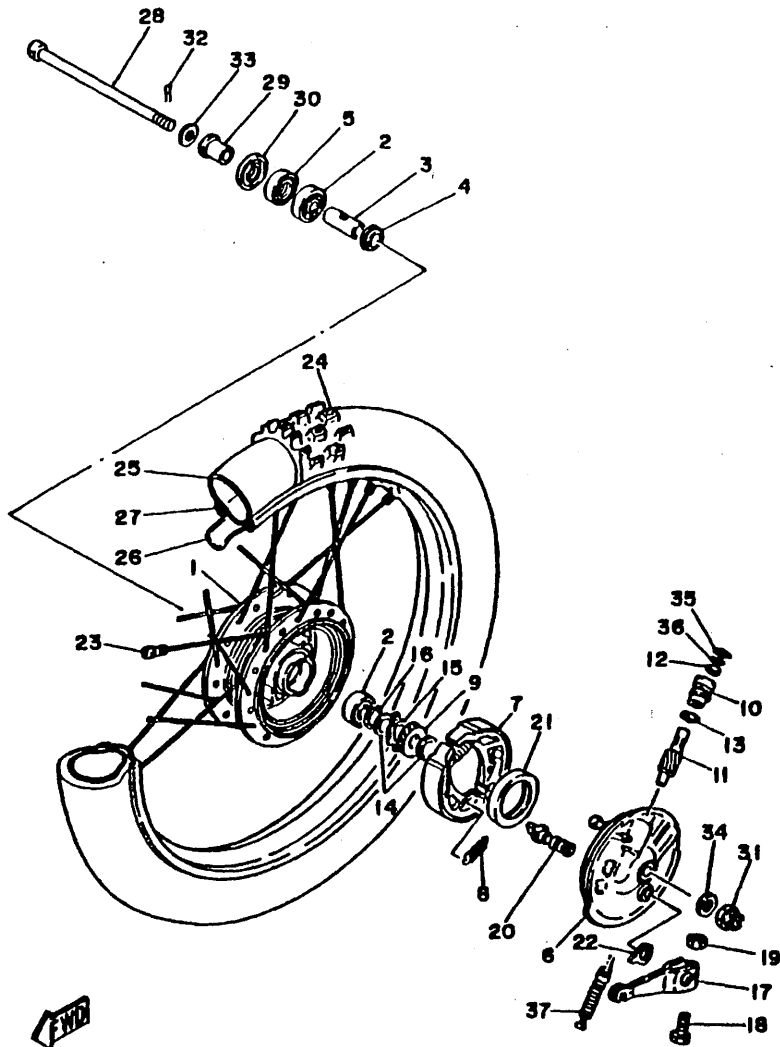

FWD
36X5700-2260

D6

FIG. 27 REAR WHEEL

REF. NO.	PART NO.	DESCRIPTION	Q'TY	REMARKS
1	391-25311-00-38	HUB, rear	1	CLEAR (WITH BUFF)
2	90560-15136	SPACER	1	
3	146-25116-00	FLANGE, spacer 2	1	
4	93306-20204	BEARING (B6202Z)	2	
5	93104-22018	OIL SEAL	1	
6	93210-42101	O-RING	1	
7	36X-25364-00	DAMPER	4	
8	437-25026-10-35	BRAKE SHOE PLATE ASSY	1	SILVER
9	90480-10068	GROMMET	1	
10	3FA-W2536-00	BRAKE SHOE SET	1	
11	90506-16447	SPRING, tension	2	
12	2RH-25351-00	CAMSHAFT	1	
13	4V8-25355-00	LEVER, camshaft	1	
14	90101-06291	BOLT	1	
15	5T9-2533A-00	PLATE, indicator	1	
16	31G-25366-00	CLUTCH, hub	1	
17	93306-00406	BEARING (B6004Z)	1	
18	93106-26005	OIL SEAL	1	
19	15A-25454-10	SPROCKET, driven (54T)	1	
20	90116-08425	BOLT, stud	6	
21	90215-08160	WASHER, lock	3	
22	90170-08258	NUT	6	
23	36X-25327-00	COVER, plate	1	
24	3V6-25304-00	SPOKE SET, rear	1	
25	94141-185E8	TIRE (4.10-18)	1	
26	94235-18085	TUBE (3.50-18)	1	YOKOHAMA
27	94325-18043	BAND, rim (2.50-18)	1	INOUE
28	94418-18246	RIM (1.85-18)	1	

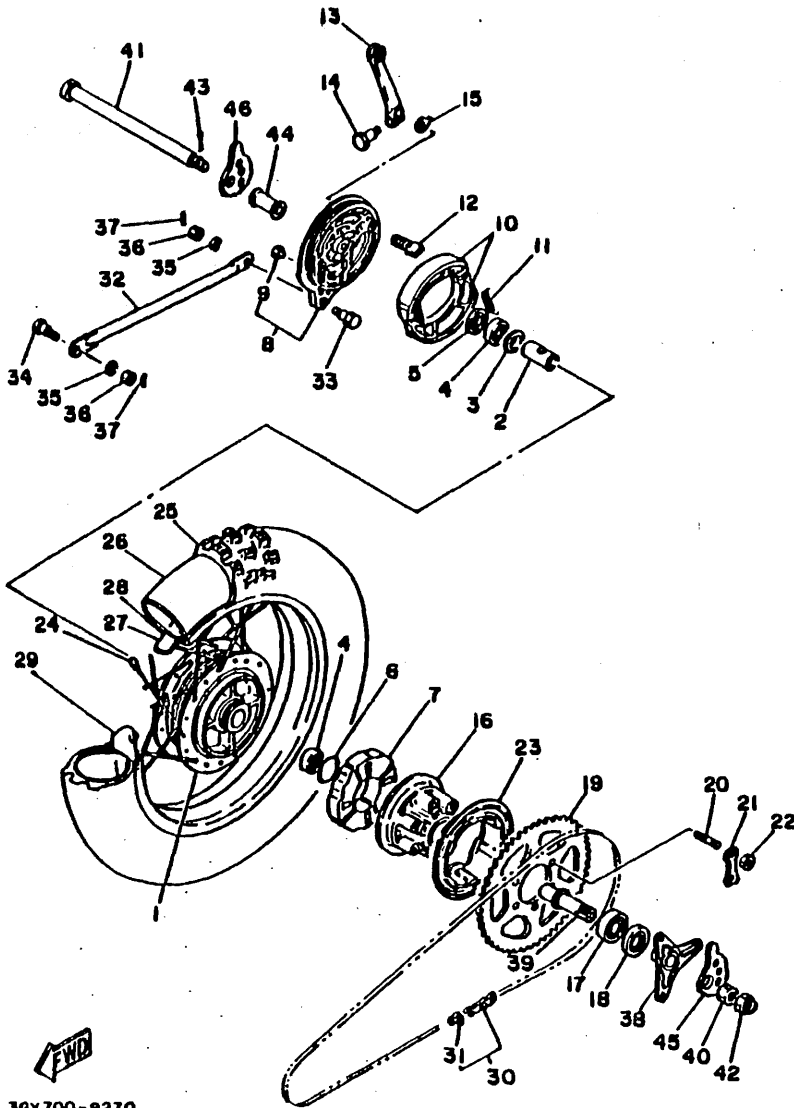

36X700-8270

D7

FIG. 27 REAR WHEEL

REF. NO.	PART NO.	DESCRIPTION	Q'TY	REMARKS
29	1T2-25394-00	SPACER, head	1	
30	94580-33126	CHAIN (D.I.D.428DS-126L)	1	
31	94680-33001	.JOINT, chain (D.I.D.428DS)	1	
32	3V6-25371-00	BAR, tension	1	
33	90109-08063	BOLT	1	
34	90109-08368	BOLT	1	
35	92990-08100	WASHER, spring	2	
36	95303-08700	NUT.	2	
37	91401-20015	PIN, cotter	2	
38	36X-25386-00	COLLAR, sprocket axle	1	
39	36X-25387-00	AXLE, sprocket	1	
40	90170-20167	NUT	1	
41	2K6-25381-00	AXLE, wheel	1	
42	90171-14020	NUT, castle	1	
43	91401-30030	PIN, cotter	1	
44	90387-155J5	COLLAR	1	
45	3V6-25388-00	PULLER, chain 1	1	
46	3V6-25389-00	PULLER, chain 2	1	

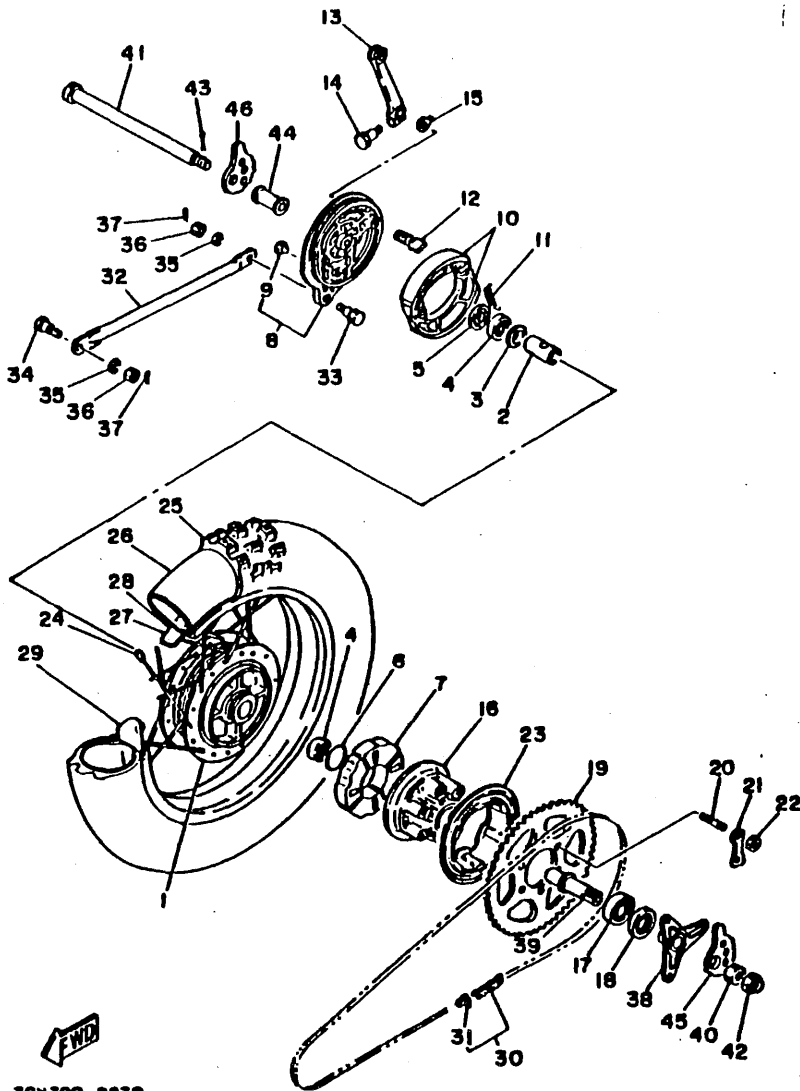

30X700-8270

D8

FIG. 28 STEERING HANDLE. CABLE

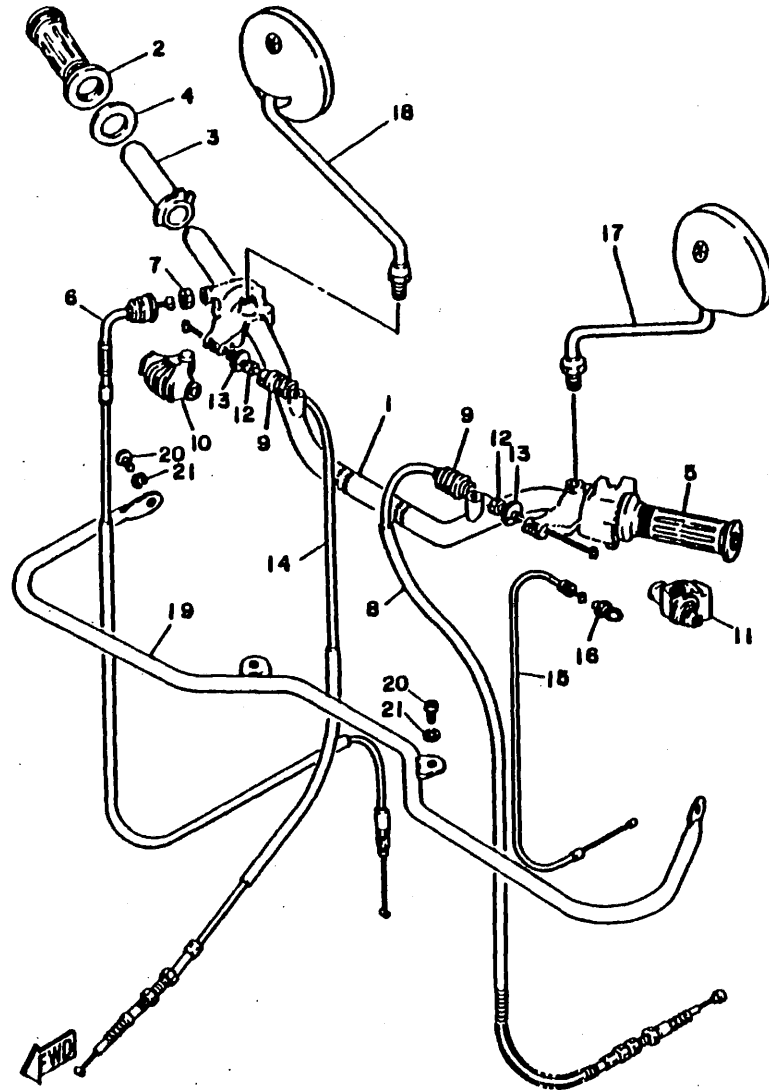

REF. NO.	PART NO.	DESCRIPTION	Q'TY	REMARKS
1	36X-26111-00	HANDLEBAR	1	YAMAHA BLACK
2	2H3-26242-00	GRIP (R.H)	1	BLACK
3	434-26243-00	TUBE, throttle guide	1	
4	1H1-26249-01	RING, leaf	1	
5	2H3-26241-00	GRIP (L.H)	1	BLACK
6	36X-26311-00	CABLE, throttle 1	1	
7	90170-10038	NUT	1	
8	1RH-26335-00	CABLE, clutch	1	
9	1E6-26342-00	BOOT, cable	2	
10	1E6-26372-00	COVER, handle lever 1	1	
11	36X-26372-00	COVER, handle lever 1	1	
12	90123-08046	BOLT	2	
13	90179-08148	NUT	2	
14	36X-26341-00	CABLE, brake	1	
15	36X-26331-00	CABLE, starter 1	1	
16	5Y1-26339-00	BOOT	1	
17	1Y1-26290-50	BACK MIRROR ASSY (L.H)	1	
18	1Y1-26290-60	BACK MIRROR ASSY (R.H)	1	
19	36X-26123-00	GUARD, lever	1	
20	92016-08016	SCREW	4	
21	92906-08100	WASHER, spring	4	

3GX700-8260

D9

FIG. 30 GENERATOR

REF. NO.	PART NO.	DESCRIPTION	Q'TY	REMARKS
1	36X-85550-M0	ROTOR ASSY	1	
2	36X-81410-M0	STATOR ASSY	1	
3	15A-85580-M0	COIL, pulser	1	
4	98501-05030	SCREW, pan head	2	
5	92990-05100	WASHER, spring	2	
6	98503-05025	SCREW, pan head	2	
7	92990-05100	WASHER, spring	2	
8	92501-06020	SCREW, pan head	2	

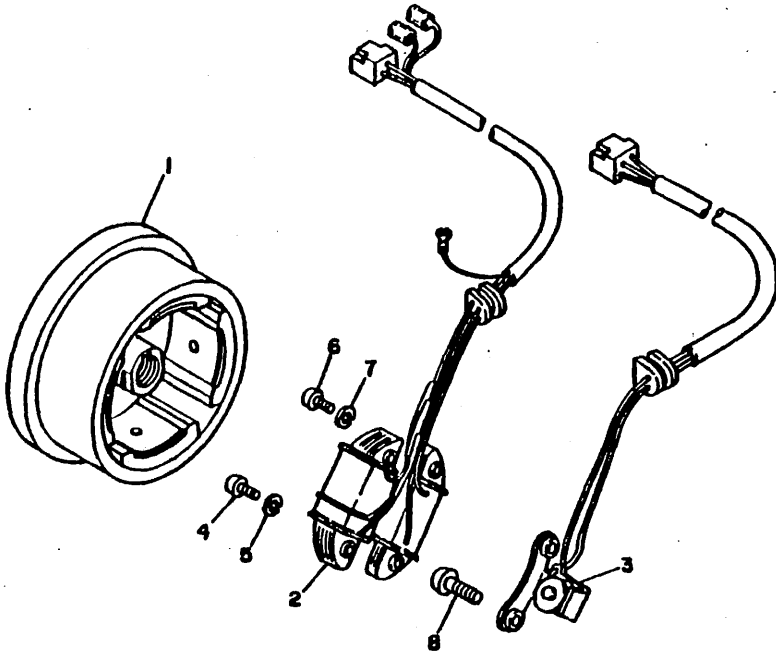

36X700-3301

D11

FIG. 31 FLASHER LIGHT

REF. NO.	PART NO.	DESCRIPTION	Q'TY	REMARKS
1	36X-83310-10	FRONT FLASHER LIGHT ASSY 1	1	
2	36X-83312-00	.LENS, flasher	1	
3	97706-30108	.SCREW, tapping	1	
4	185-83311-10	.BULB (6V-8W)	1	
5	36X-83321-00	.DAMPER, flasher 1	1	
6	36X-83318-00	STAY, flasher 1	1	
7	92506-06016	SCREW, pan head	1	
8	92906-06600	WASHER, plate	1	
9	36X-83320-10	FRONT FLASHER LIGHT ASSY 2	1	
10	36X-83312-00	.LENS, flasher	1	
11	97706-30108	.SCREW, tapping	1	
12	185-83311-10	.BULB (6V-8W)	1	
13	36X-83321-00	.DAMPER, flasher 1	1	
14	36X-83328-00	STAY, flasher 2	1	
15	92506-06016	SCREW, pan head	1	
16	92906-06600	WASHER, plate	1	
17	36X-83310-10	FRONT FLASHER LIGHT ASSY 1	1	
18	36X-83312-00	.LENS, flasher	1	
19	97706-30108	.SCREW, tapping	1	
20	185-83311-10	.BULB (6V-8W)	1	
21	36X-83321-00	.DAMPER, flasher 1	1	
22	36X-83320-10	FRONT FLASHER LIGHT ASSY 2	1	
23	36X-83312-00	.LENS, flasher	1	
24	97706-30108	.SCREW, tapping	1	
25	185-83311-10	.BULB (6V-8W)	1	
26	36X-83321-00	.DAMPER, flasher 1	1	

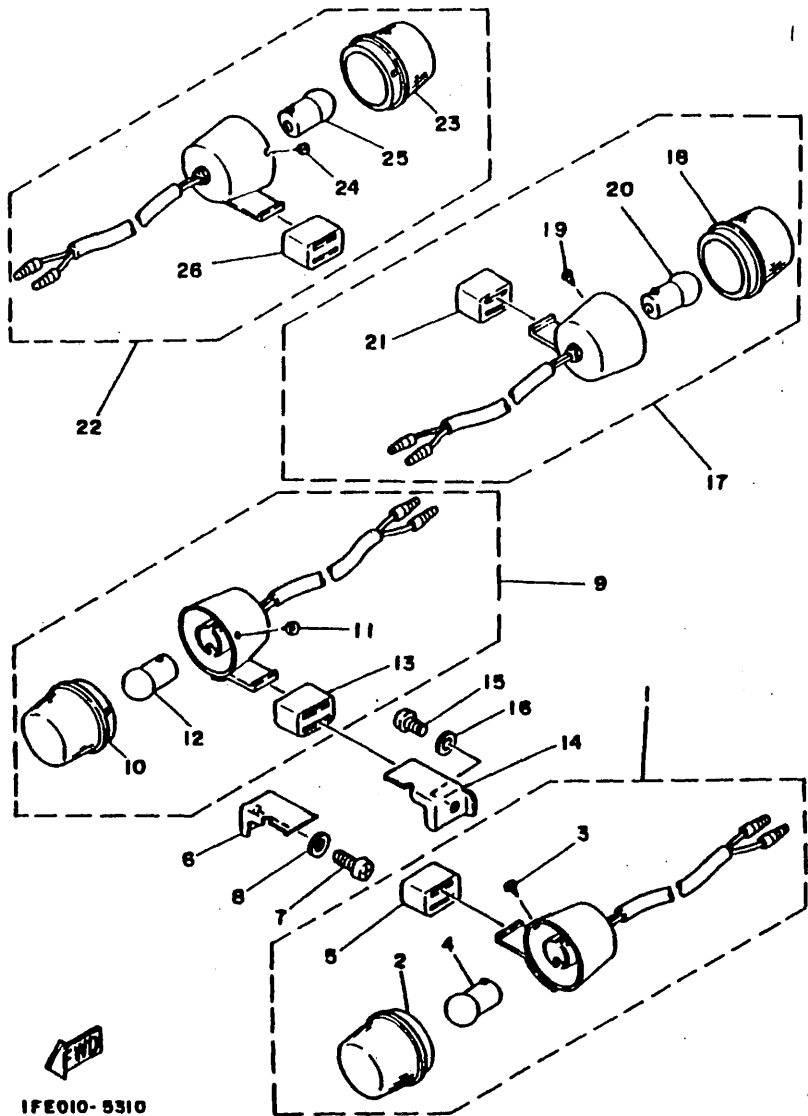



 IFE010-5310

D12

FIG. 32 METER

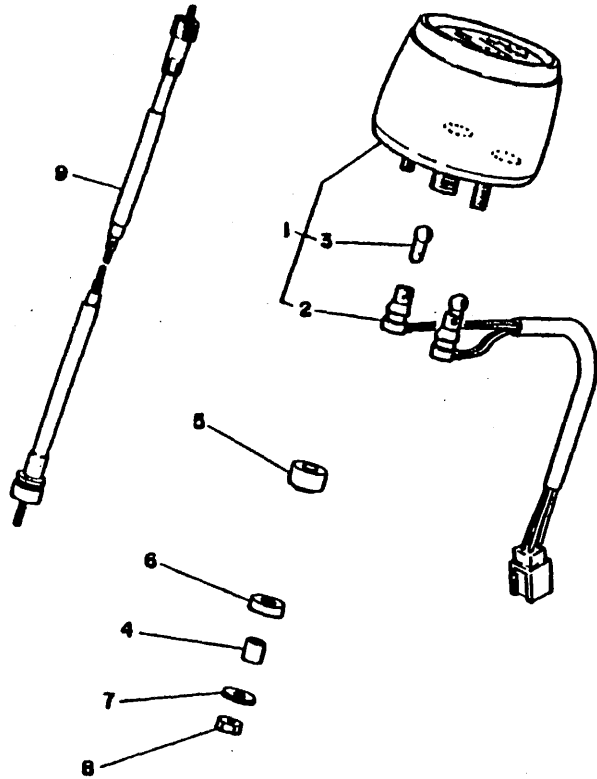
REF. NO.	PART NO.	DESCRIPTION	Q'TY	REMARKS
1	3F4-83510-F0	SPEEDOMETER ASSY	1	KM/H
2	4A7-83520-00	.SOCKET CORD ASSY	1	
3	4N0-83516-00	.BULB (6V-3W)	2	
4	355-83522-00	COLLAR	2	
5	1M3-83513-00	DAMPER	2	
6	355-83526-00	DAMPER 2	2	
7	90201-06412	WASHER, plate	2	
8	96303-06600	NUT	2	
9	1JN-83550-01	SPEEDOMETER CABLE ASSY	1	



3GX700-8320

D13

FIG. 33 HEADLIGHT

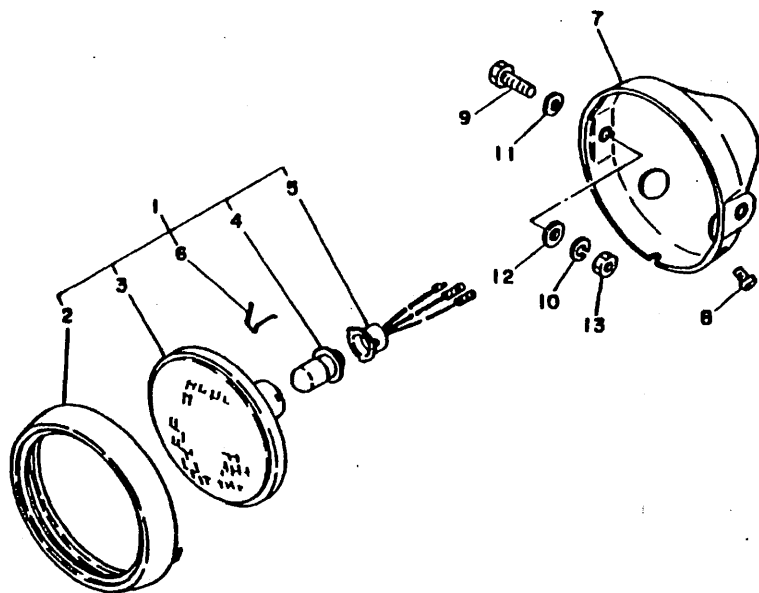

REF. NO.	PART NO.	DESCRIPTION	Q'TY	REMARKS
1	3M7-84110-00	HEADLIGHT UNIT ASSY	1	
2	202-84315-00	.RIM, headlight	1	
3	195-84320-00	.LENS ASSY	1	
4	206-84114-60	.BULB (6V-25/25W)	1	
5	452-84112-00	.SOCKET	1	
6	195-84324-00	.SPRING, reflector	3	
7	3M7-84130-00	BODY ASSY, headlight	1	
8	98506-05012	SCREW, pan head	1	
9	97001-08025	BOLT	2	
10	92990-08100	WASHER, spring	2	
11	92901-08600	WASHER, plate	2	
12	92990-08200	WASHER, plain	2	
13	95303-08600	NUT	2	

5V6700-2310

D14

FIG. 34 TAILLIGHT

REF. NO.	PART NO.	DESCRIPTION	Q'TY	REMARKS
1	36X-84510-00	TAILLIGHT UNIT ASSY	1	
2	1Y1-84521-30	.LENS, taillight	1	
3	98511-03045	.SCREW, pan head	2	
4	122-84514-30	.BULB (6V-17/5.3W)	1	
5	36X-84527-00	DAMPER	1	
6	90387-05563	COLLAR	2	
7	90201-054K4	WASHER, plate	2	
8	97001-05020	BOLT	2	
9	92901-05100	WASHER, spring	2	
10	92901-05600	WASHER, plate	2	

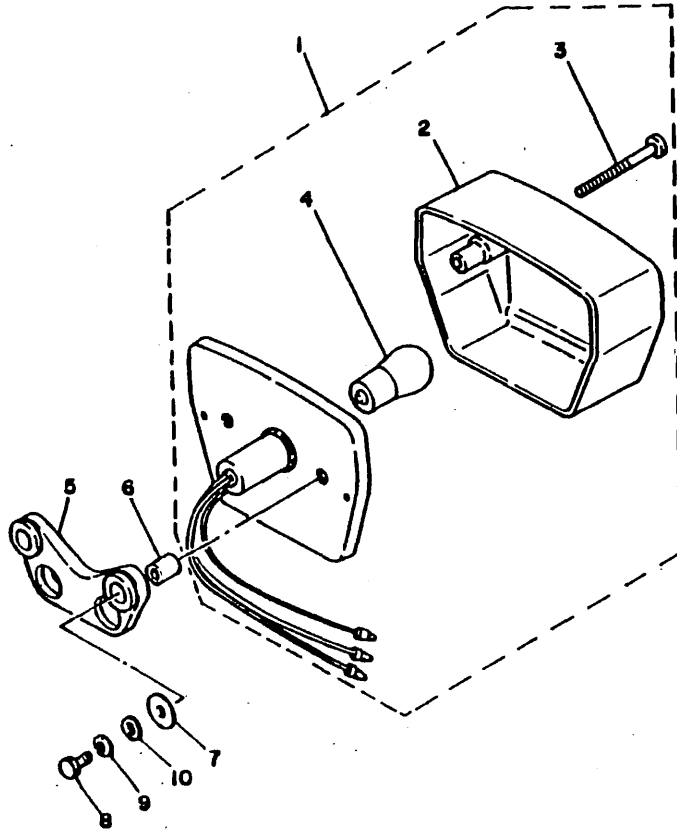

36X700-3340

D15

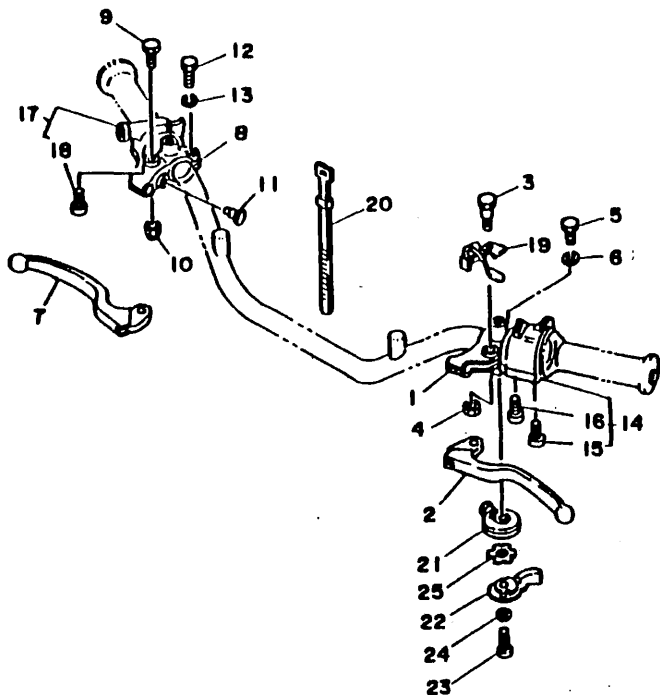

FIG. 35 HANDLE SWITCH. LEVER

REF. NO.	PART NO.	DESCRIPTION	Q'TY	REMARKS
1	5Y1-82911-01	HOLDER, lever 1	1	
2	23X-83912-00	LEVER 1	1	
3	90109-06799	BOLT	1	
4	95616-06100	NUT, u	1	
5	97006-06022	BOLT	1	
6	92906-06100	WASHER, spring	1	
7	23X-83922-00	LEVER 2	1	
8	361-82921-31	HOLDER, lever 2	1	
9	90109-06799	SCREW	1	
10	95616-06100	NUT, u	1	
11	503-83956-00	CAP 1	1	
12	97006-06022	BOLT	1	
13	92906-06100	WASHER, spring	1	
14	36X-83972-00	SWITCH, handle 4	1	
15	98506-05025	.SCREW, pan head	1	
16	98506-05030	.SCREW, pan head	1	
17	1R6-83976-01	SWITCH, handle 1	1	
18	90157-05027	.SCREW, pan head	2	
19	36X-83965-00	LEVER, lock	1	
20	437-83936-01	BAND, switch cord	4	
21	5Y1-83942-00	COVER, starter	1	
22	5Y1-83941-00	LEVER, starter	1	
23	98506-06035	SCREW, pan head	1	
24	92906-06200	WASHER, plain	1	
25	90209-10131	WASHER	1	



30X5700-2350

E2

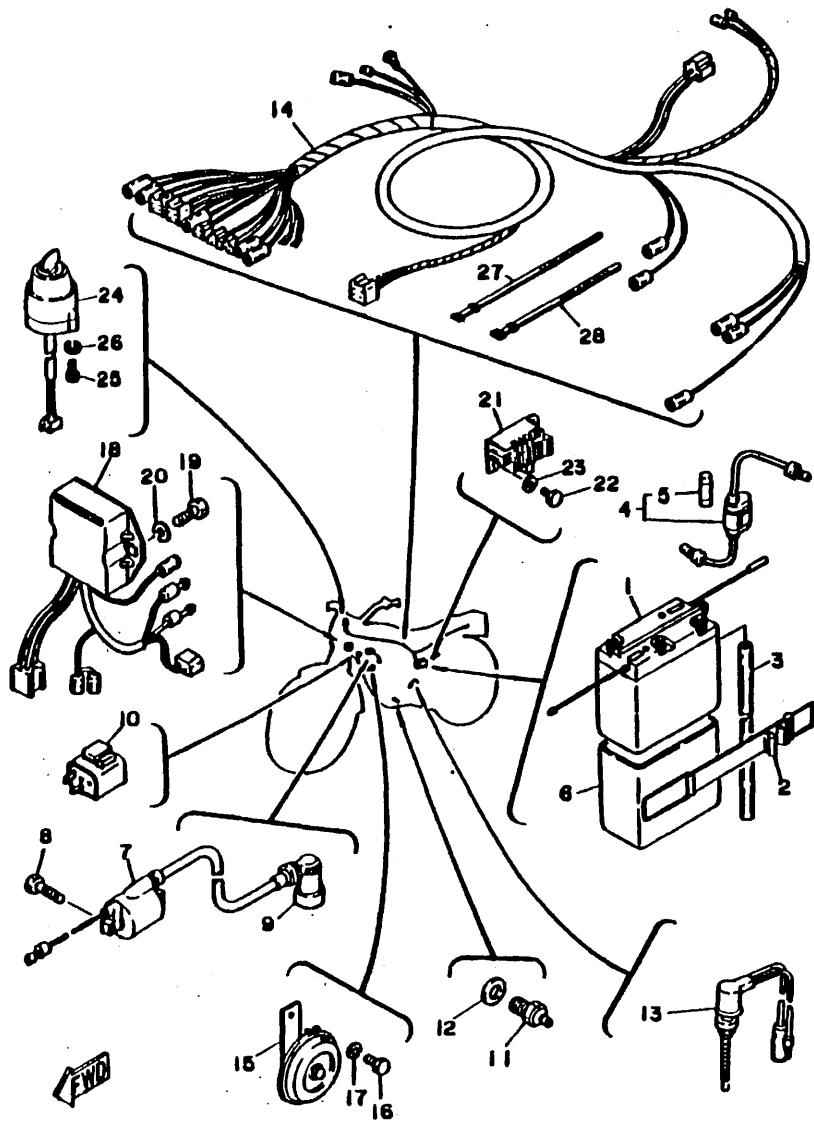

FIG. 36 ELECTRICAL 1

REF. NO.	PART NO.	DESCRIPTION	Q'TY	REMARKS
1	558-82110-29	BATTERY ASSY (6N4B-2A-3)	1	
2	36X-82131-00	BAND, battery	1	
3	90445-08171	HOSE	1	
4	55K-82150-01	FUSE HOLDER ASSY	1	
5	116-82151-00	.FUSE (10A)	2	
6	36X-82122-00	SEAT, battery	1	
7	32N-82310-M0	IGNITION COIL ASSY	1	
8	92502-06016	SCREW, pan head	2	
9	55X-82370-00	PLUG CAP ASSY	1	
10	36X-83350-10	FLASHER RELAY ASSY.	1	
11	2H7-82540-00	NEUTRAL SWITCH ASSY	1	
12	90430-10027	GASKET	1	
13	2F1-82530-02	STOP SWITCH ASSY	1	
14	36X-82590-01	WIRE HARNESS ASSY	1	
15	36X-83371-11	HORN	1	
16	97001-06012	BOLT	2	
17	92990-06100	WASHER, spring	2	
18	12V-85540-M0	C.D.I. UNIT ASSY	1	
19	97002-06016	BOLT	2	
20	92990-06100	WASHER, spring	2	
21	18A-81960-60	RECTIFIER & REGULATOR ASSY	1	
22	97001-05012	BOLT	2	
23	92901-05600	WASHER, plate	2	
24	1FE-82510-00	MAIN SWITCH ASSY	1	
25	98501-05012	SCREW, pan head	2	
26	92901-05100	WASHER, spring	2	
27	437-83936-11	BAND, switch cord	1	
28	3TB-83936-00	BAND, switch cord	3	

3GX4700-1360

E3

NUMERICAL INDEX

PART NO.	GRID NO.	PART NO.	GRID NO.	PART NO.	GRID NO.	PART NO.	GRID NO.	PART NO.	GRID NO.	PART NO.	GRID NO.
3FA-W2536-00	D-7	30X-12213-00	B-7	36X-14752-01	B-12	24W-17131-00	C-5	1W1-22128-00	C-13	36X-23170-00	D-2
4BE-W2536-00	D-5	5HO-12231-00	B-7	480-14766-00	B-12	36X-17141-01	C-5	401-22128-01	C-11	1W1-23173-LO	C-15
36X-W2810-00	D-4	5HO-12241-00	B-7		B-12	36X-17151-00	C-5	36X-22141-01	C-11		C-15
36X-11102-01	B-2	36X-12283-00	B-2	36X-1490J-00	B-10	36X-17211-00	C-5	36X-22151-00	C-12	278-23181-50	C-15
5HO-1111F-00	B-2	36X-12288-00	B-7	36X-1490K-00	B-10	36X-17221-00	C-5	36X-22189-00	C-12		D-2
5HO-11133-10	B-2	36X-12292-00	B-2	36X-14901-00	B-10	24W-17231-00	C-5	36X-22210-10	C-13	36X-23191-01	C-15
5HO-11161-00	B-3	5HO-13300-00	B-8	36X-14933-01	B-10	36X-17241-01	C-5	1YW-22216-00	C-13		D-2
15A-11162-00	B-3	36X-13324-00	B-8	25G-14937-00	B-11	36X-17251-00	C-5	3R4-22226-00	C-13	36X-23192-00	C-15
	B-3	5HO-13326-00	B-8	36X-14940-00	B-10	15A-17402-01	C-5	36X-22310-00-35	C-11		D-2
36X-11166-00	B-13	4BE-13329-00	B-8	36X-14941-42	B-10	36X-17411-00	C-5	148-22315-00	C-11	4V2-23194-LO	C-15
371-11167-01	B-13	51Y-13411-00	B-8	4G0-14984-00	B-10	5HO-17456-00	C-5	36X-22318-00	C-11		D-2
1NU-11181-00	B-2	5HO-13440-00	B-8	4G0-14985-00	B-10	2W5-18111-00	C-7	36X-22323-00	C-11	36X-2331E-00	C-14
36X-11185-00	B-2	36X-13447-00	B-8	3F7-14991-00	B-10	132-18113-01	C-7	36X-22324-00	C-11	3R9-23318-00	C-14
5HO-11186-00	B-2	24W-13512-00	B-9	256-14997-00	B-10	36X-18120-02	C-7	36X-22325-00	C-11	311-23319-00	C-14
36X-11187-00	B-2	16G-13569-00	B-9	36X-15100-01	B-13	4G0-18140-00	C-6	36X-22327-00	C-12	36X-23340-00-33	D-2
36X-11310-00	B-3	1HX-13575-00	B-9	5HO-15351-00	B-8	5HO-18185-01	C-6	36X-22358-00	C-11	36X-23389-00	C-14
4CS-11351-00	B-3	36X-13586-00	B-9	3Y1-15361-00	B-14	5HO-18511-00	C-6	36X-23102-00	C-15	5Y1-23389-00	D-2
15A-11400-00	B-4	36X-1410A-00	B-10	1RG-15363-00	B-14	5HO-18512-00	C-6	36X-23103-00	C-15	36X-23392-00	D-2
15A-11412-09	B-4	36X-14105-00	B-10	36X-15378-00	B-14	36X-18513-00	C-6	36X-23106-00-35	C-15	156-23411-00	C-14
5HO-11422-00	B-4	25G-14107-20	B-10	36X-15411-00	B-14	5HO-18531-00	C-6	36X-23107-00-35	C-15	22F-23411-01	C-14
15A-11454-00	B-4	22F-14126-00	B-10	36X-15421-00	B-14	4DN-18535-00	C-6	36X-23110-00	C-15	156-23412-00	C-14
5HO-11496-00	B-4	81Z-14137-00	B-10	36X-15431-01	B-14	36X-18540-00	C-6		C-15	22F-23412-01	C-14
5HO-11531-00	B-4	4G0-14142-35-AO	B-10	15A-15441-00	B-3	136-18542-00	C-6	1UG-23111-M1	C-15	36X-23416-00	C-14
5HO-11536-00	B-4	36X-14146-00	B-10	15A-15451-01	B-14	36X-21107-00	D-4		D-2	36X-23435-00	C-14
15A-11603-00	B-4	137-14153-00	B-10	4BE-15462-00	B-14	36X-21110-00-33	C-8	240-23114-00	C-15	1E6-23441-00	C-14
15A-11605-00	B-4	36X-14153-00	B-10	36X-1561A-00	B-15	36X-21287-00	C-8		D-2	164-23462-00	C-14
15A-11607-00	B-4	36X-14169-00	B-10	36X-1561G-00	B-15	36X-21315-00	C-8	36X-23118-00	C-15	36X-24110-00-03	D-3
36X-11631-00-AO	B-4	537-14186-00	B-10	36X-15620-01	B-15	36X-21316-00	C-8		D-2	4H7-24181-00	D-3
5BL-11633-00	B-4	36X-14191-00	B-10	36X-15621-01	B-15	36X-21471-00	C-8	4H7-23119-00	C-15	36X-24182-00	D-3
36X-11636-00	B-4	21Y-14196-00	B-11	36X-15641-00	B-15	36X-21485-00	C-8		D-2	36X-24186-00	D-3
36X-11638-00	B-4	36X-14197-00	B-10	15A-15651-01	B-15	36X-21511-10	C-9	36X-23128-00	D-2	3GX-24244-10	D-3
15A-11651-00	B-4	3G2-14231-25	B-10	36X-15660-01	B-15	36X-21521-00	C-9	122-23129-00	C-15	15A-24500-03	D-3
5HO-11681-00	B-4	620-14231-74-AO	B-10	15A-15666-00	B-15	36X-21522-00	C-9		D-2	4X8-24512-00	D-3
5HO-12111-00	B-6	36X-14401-00	B-9	401-15676-00	B-15	36X-21611-10	C-9	36X-23141-00	C-15	3AJ-24523-00	D-3
4G0-12113-01	B-6	36X-14412-00	B-9	36X-16111-00	C-3	36X-21621-00	C-9		D-2	3AJ-24534-00	D-3
4G0-12114-01	B-6	36X-14437-00	B-9	36X-16150-00	C-3	36X-21622-00	C-9	583-23142-00	C-15	36X-24610-00	D-3
4G0-12116-01	B-6	36X-14451-00	B-9	5HO-16154-00	C-3	36X-21629-00	C-9		D-2	36X-24710-20	D-4
4G0-12117-00	B-6	36X-14453-01	B-9	36X-16321-00	C-3	36X-21711-10	C-10	4G0-23144-01	C-15	36X-24711-00	D-4
4G0-12118-00	B-6	36X-14458-00	B-9	537-16321-00	C-3	36X-2172A-00	C-10		C-15	36X-24810-00-98	D-4
5HO-12119-00	B-6	51Y-14462-00	B-9	137-16324-00	C-3	36X-21721-10	C-10	173-23145-00	C-15	36X-24860-00-98	D-4
5HO-12121-00	B-6	36X-14468-00	B-9	5HO-16351-00	C-3	3M7-21746-00	C-10		C-15	36X-24861-00	D-4
5HO-12146-00	B-6	36X-14611-01	B-12	5HO-16356-01	C-3	36X-2177F-00	C-10	4A1-23156-00	C-15	36X-24862-00	D-4
36X-12151-00	B-6	5HO-14612-00	B-12	5HO-16357-00	C-3	36X-21781-20	C-10		C-15	437-25026-10-35	D-7
5HO-12156-00	B-6	4BE-14613-00	B-12	30X-16358-00	C-3	36X-22110-00-35	C-11	509-23158-LO	C-15	3V6-25104-00	D-5
3Y1-12159-00	B-6	1FE-14628-00	B-12	36X-16371-00	C-3	15A-22123-00	C-11		D-2	248-25111-00-78	D-5
36X-12171-00	B-7	36X-14711-01	B-12	15A-16380-00	C-3	36X-22126-00	C-11	1UG-23168-M1	C-15	146-25116-00	D-7
5HO-12176-00	B-7	3YF-14714-00	B-12	36X-16383-00	C-3	36X-22126-10	C-11		D-2	2K5-25118-00	D-6
3GC-12210-10	B-7	1FE-14728-00	B-12	24W-17121-00	C-5	401-22127-00	C-11	36X-23170-00	C-15	23F-25121-00-35	D-5

NUMERICAL INDEX

PART NO.	GRID NO.	PART NO.	GRID NO.	PART NO.	GRID NO.	PART NO.	GRID NO.	PART NO.	GRID NO.	PART NO.	GRID NO.
36X-25135-00	D-5	36X-2811G-00	D-4	5Y1-83941-00	E-2	90149-08067	C-3	90201-20269	D-5	90465-16187	B-14
109-25136-00	D-5	36X-81410-MO	D-11	5Y1-83942-00	E-2	90151-06013	C-6	90201-203E7	C-5	90467-09006	D-3
102-25137-00	D-6	18A-81960-60	E-3	503-83956-00	E-2	90153-06029	B-2	90202-05193	D-3	90467-10039	B-9
36X-25138-00	D-5	558-82110-29	E-3	36X-83965-00	E-2	90157-05027	E-2	90206-06090	B-12	90467-14015	B-13
183-25149-00	D-5	36X-82122-00	E-3	36X-83972-00	E-2	90157-06048	B-15		B-12	90468-06134	C-12
5H0-25155-00	D-5	36X-82131-00	E-3	1R6-83976-01	E-2	90159-05011	C-3	90209-10131	E-2	90468-26122	B-15
3V6-25304-00	D-7	55K-82150-01	E-3	3H7-84110-00	D-14	90159-06085	C-9	90209-16209	C-5	90480-01141	C-10
391-25311-00-38	D-7	116-82151-00	E-3	452-84112-00	D-14	90170-06128	B-6	90209-17226	B-15	90480-10068	D-7
109-25315-00	D-5	32N-82310-MO	E-3	206-84114-60	D-14	90170-08258	D-14	90209-18208	C-5	90480-12320	C-10
36X-25327-00	D-7	55X-82370-00	E-3	3H7-84130-00	D-14	90170-10038	D-9	90214-17028	B-15	90480-14229	C-8
23F-2533A-00	D-5	1FE-82510-00	E-3	202-84315-00	D-14	90170-14284	B-5	90214-20023	B-4	90501-07629	B-4
5T9-2533A-00	D-7	2F1-82530-02	E-3	195-84320-00	D-14		C-3	90215-06184	B-2	90501-10245	D-10
2RH-25351-00	D-7	2H7-82540-00	E-3	195-84324-00	D-14		C-3	90215-08160	D-7	90501-12081	B-15
3Y6-25351-00	D-5	36X-82590-01	E-3	36X-84510-00	D-15	90170-20167	D-8	90215-14205	B-5	90501-12792	D-6
4V8-25355-00	D-7	5Y1-82911-01	E-2	122-84514-30	D-15	90171-10004	D-6		C-3	90501-18576	B-8
36X-25364-00	D-7	361-82921-31	E-2	1Y1-84521-30	D-15	90171-14020	D-8	90215-14224	C-3	90501-21133	B-4
316-25366-00	D-7	36X-83310-10	D-12	36X-84527-00	D-15	90175-06013	D-10	90240-06040	D-10	90501-23700	C-3
3V6-25371-00	D-8		D-12	12V-85540-MO	E-3	90179-08148	D-9	90240-07083	B-4	90506-08227	C-7
2K6-25381-00	D-8	185-83311-10	D-12	36X-85550-MO	D-11	90179-25033	C-14	90240-12092	C-13	90506-14343	D-10
353-25381-00	D-5		D-12	15A-85580-MO	D-11	90185-08089	C-8	90249-12008	D-10	90506-15260	D-5
36X-25386-00	D-8		D-12	90101-06278	D-5		C-8	90280-05013	B-5	90506-16447	D-7
36X-25387-00	D-8		D-12	90101-06291	D-7		C-8	90282-05013	B-5	90506-26270	D-10
3V6-25388-00	D-8	36X-83312-00	D-12	90101-10188	B-5	90185-10037	D-10	90282-05043	C-3	90508-14620	B-15
3V6-25389-00	D-8		D-12	90101-10303	B-7	90185-10091	C-14	90340-14068	B-14	90508-16428	B-7
1T2-25394-00	D-8		D-12	90105-08141	B-12	90185-12072	C-11	90340-32069	B-14	90508-18537	C-3
15A-25454-10	D-7		D-12		D-4	90201-05032	C-12	90380-12051	C-13	90508-20023	D-10
36X-26111-00	D-9	36X-83318-00	D-12	90105-08155	C-8	90201-054K4	D-15	90386-14103	C-3		D-10
36X-26123-00	D-9	36X-83320-10	D-12	90105-08195	B-2	90201-06412	D-13	90386-18028	C-11	90508-26538	B-15
2H3-26241-00	D-9		D-12	90105-10058	D-10	90201-065F3	C-9	90387-051K7	B-9	90508-26539	C-6
2H3-26242-00	D-9	36X-83321-00	D-12	90105-14102	C-14	90201-07076	D-5	90387-05563	D-15	90508-29540	C-7
434-26243-00	D-9		D-12	90109-06418	B-7	90201-080L7	B-2	90387-062V8	C-9	90560-12138	D-5
1H1-26249-01	D-9		D-12	90109-06755	B-8	90201-081H4	B-12	90387-06681	C-12	90560-15136	D-7
1Y1-26290-50	D-9		D-12	90109-06799	E-2		D-4	90387-12265	D-6	91311-06018	B-2
1Y1-26290-60	D-9	36X-83328-00	D-12		E-2	90201-094G1	C-8	90387-125F1	B-13	91311-06025	B-7
36X-26311-00	D-9	36X-83350-10	E-3	90109-08063	D-8		C-8		B-13	91311-06030	B-3
36X-26331-00	D-9	36X-83371-11	E-3	90109-08368	D-8		C-8	90387-155J5	D-8	91311-08045	B-2
1RH-26335-00	D-9	3F4-83510-FO	D-13	90109-103A1	D-10	90201-102G9	C-13	90387-255F3	B-7	91316-06020	B-9
5Y1-26339-00	D-9	1H3-83513-00	D-13	90109-10554	C-13	90201-105J4	B-15	90430-06014	B-2		B-12
36X-26341-00	D-9	4N0-83516-00	D-13	90110-06064	B-2	90201-10508	B-5		C-7	91316-08025	B-12
1E6-26342-00	D-9	4A7-83520-00	D-13	90116-08425	D-7	90201-10644	B-15	90430-08119	C-3	91401-20015	D-8
1E6-26372-00	D-9	355-83522-00	D-13	90119-06061	D-4	90201-10774	B-7	90430-10027	E-3		D-10
36X-26372-00	D-9	355-83526-00	D-13	90119-06063	C-9	90201-122A7	D-6	90430-14131	B-2	91401-20020	D-6
36X-27211-00-90	D-10	1JN-83550-01	D-13		C-9	90201-12588	B-7	90445-08171	E-3	91401-25015	D-10
36X-27231-00	D-10	23X-83912-00	E-2	90119-06074	C-11		C-7	90445-10638	D-3		D-10
36X-27311-00-R4	D-10	23X-83922-00	E-2	90119-06097	C-9	90201-17257	C-5	90460-56105	B-9	91401-30025	C-13
36X-27311-10-R4	D-10	37B-83936-00	E-3	90122-06012	B-9	90201-173F4	B-15	90464-16021	C-9	91401-30030	D-8
36X-27410-00-90	D-10	437-83936-01	E-2	90123-08046	D-9	90201-175F6	B-15	90465-08188	B-14	91701-08038	D-10
36X-27420-00-90	D-10	437-83936-11	E-3	90149-06011	D-3	90201-201E4	B-4	90465-08200	B-13		D-10

NUMERICAL INDEX

PART NO.	GRID NO.	PART NO.	GRID NO.	PART NO.	GRID NO.	PART NO.	GRID NO.	PART NO.	GRID NO.	PART NO.	GRID NO.
92016-08016	D- 9	92990-08100	D- 8	93450-17044	B- 4	95821-12025	D-10	98503-05025	D-11		
92501-06012	C-10		D-14	93501-04011	C-14	95826-10060	C-14	98503-06045	B-14		
92501-06020	D-11	92990-08200	D-14	93503-16010	C-14	97001-05012	E- 3		C-11		
92502-06016	E- 3	92990-12600	C-13	93505-16006	C- 3	97001-05020	D-15	98506-04030	C-11		
92506-06012	C-14	93101-15101	C- 5	93507-32031	B-15	97001-06012	C- 8	98506-05012	D-14		
92506-06016	D-12	93102-10207	B-15	93602-13177	B- 4		E- 3	98506-05016	B- 9		
	D-12	93102-12106	B- 7	93603-12030	B- 8	97001-06020	D-10	98506-05025	E- 2		
92901-05100	D-15		C- 7	93604-10011	B- 7	97001-08025	D-14	98506-05030	E- 2		
	E- 3	93102-14209	C- 4	93604-16092	C- 6	97002-06016	C-12	98506-06008	B-12		
92901-05600	C-14	93102-17263	B-15	93604-20156	C- 6		D- 3	98506-06035	E- 2		
	D-15	93102-18008	D- 5	93605-10090	B- 4		E- 3	98511-03045	D-15		
	E- 3	93102-20242	C- 5	93608-50158	C- 7	97003-06012	B- 2	98701-06030	B- 8		
92901-06200	C- 3	93104-07003	D- 5	93700-06004	C-11	97006-06012	C-14	98906-06010	B-12		
	D-10	93104-22018	D- 7	93700-06009	C-11	97006-06022	E- 2		B-12		
92901-06600	B- 7	93105-47007	D- 5	93822-14043	C- 5		E- 2	99001-10600	C- 7		
	B-15	93106-26005	D- 7	94130-195E9	D- 5	97011-06020	B- 9	99009-10400	B-15		
	C-11	93109-18020	C-11	94141-185E8	D- 7		C- 7	99009-17400	B-15		
	C-11	93210-07135	B- 8	94227-19177	D- 5	97021-06010	C- 5		B-15		
92901-08600	C-12	93210-09350	B- 6	94235-18085	D- 7	97021-06016	B- 7		C- 5		
	D-14	93210-13361	B- 3	94325-18043	D- 7	97021-08030	B-15	99009-20400	D- 5		
92901-10100	B- 5	93210-14104	D- 6	94327-19111	D- 5	97313-08012	C-12	99510-12016	B-13		
92901-10200	D- 6	93210-14369	B-14	94416-19263	D- 5	97706-30108	D-12		B-14		
92902-04100	B-11	93210-19123	B-14	94418-18246	D- 7		D-12		B-14		
92906-05600	B- 9	93210-32172	B-14	94580-33126	D- 8		D-12	99530-14016	B- 2		
92906-06100	B-12	93210-35389	B- 8	94580-41104	B- 7		D-12		B- 3		
	C-14	93210-35537	B- 9	94680-33001	D- 8	97780-50512	C-12				
	C-14	93210-42101	D- 7	94701-00157	B- 2	97801-03008	D- 3				
	E- 2	93210-48364	C- 3	94701-00181	B- 2	98501-04006	B-10				
	E- 2	93210-54175	B- 8	95303-05600	C-14	98501-05008	B-10				
92906-06200	E- 2	93210-57634	B- 2	95303-06600	C- 3		C-11				
92906-06600	C-14	93210-72529	B- 3		D- 5	98501-05012	E- 3				
	D-12	93211-05471	B- 2		D-13	98501-05016	C-14				
	D-12	93306-00406	D- 7	95303-06700	C- 9	98501-05030	D-11				
92906-08100	D- 2	93306-20201	C- 5		D-10	98501-06010	B-14				
	D- 9	93306-20204	D- 7	95303-08600	D-14	98501-06016	C-11				
92906-08600	B-12	93306-20332	C- 5	95303-08700	D- 8	98501-06020	B- 2				
92990-05100	D-11	93306-20401	C- 5	95311-06700	C- 2	98501-06025	B- 8				
	D-11	93306-30103	D- 5	95601-06200	C-11		B-14				
92990-06100	B- 9	93306-30424	C- 5	95602-10100	C-13		B-14				
	C- 8	93306-30427	B- 4	95616-06100	E- 2		B-14				
	C-11		B- 4		E- 2	98501-06030	B-13				
	C-12	93306-30615	B- 4	95811-08065	C- 8	98501-06035	B-14				
	D- 3	93310-530J3	B- 4	95811-08070	C- 8		B-14				
	E- 3	93315-23607	C- 6	95811-08090	C-12	98501-06040	B-13				
	E- 3	93410-20038	C- 5	95811-08120	C- 8	98501-06075	B- 8				
92990-06200	B- 9	93410-22039	C- 5	95812-08050	C- 8	98501-06080	B-13				
92990-06600	C-10	93420-28055	C- 4	95816-08012	D- 4	98501-06085	B-13				
92990-08100	C-12	93440-10085	B- 2	95816-08035	C-14	98503-04014	B-10				

