



**PARTS
CATALOGUE
CATALOGO
DE REPUESTOS**

AG200F (3GXL) PERU

AG200F (3GXM) IVORY COAST, GUATEMALA, SOUTH AFRICA

AG200FE (3GXN) PERU

1D3GX-200E1

()



2008/1/31

NEWS NO.	DATE	COMMENT
PE0-MC-070059	Nov.,21,2007	COR:FIG.17 SHIFT CAM & FORK ILLUSTRATION CORRECTIONS

AG200F/AG200FE
PARTS CATALOGUE
©2004 by Yamaha Motor Co., Ltd.
1st edition, October 2004
All rights reserved.
Any reprinting or unauthorized use
without the written permission of
Yamaha Motor Co., Ltd.
is expressly prohibited.
Printed in Japan.

AG200F/AG200FE
CATALOGO DE REPUESTOS
©2004 por Yamaha Motor Co., Ltd.
1ª edición, octubre 2004
Todos los derechos reservados.
Toda reproducción o uso no autorizado
sin el consentimiento escrito de
Yamaha Motor Co., Ltd.
quedan expresamente prohibidos
Impreso en Japón.

FOREWORD

This Parts Catalogue is related to the parts for the model(s) on the cover page. When you are ordering replacement parts, please refer to this Parts Catalogue and quote both part numbers and part names correctly.

1. Modifications or additions which have been made after the issue of the Parts Catalogue will be announced in the Parts News.

It is advisable that you make the necessary corrections to the Parts Catalogue according to the Parts News.

2. Abbreviations

The following abbreviations are used in this Parts Catalogue.

“UR” Use specified parts number.

“UN” Use as many as needed.

“AP” Alternate Parts

“LM” Locally Made (Parts need to be ordered locally)

“F#” Frame No. (Applicable machine No.)

“O/S” Over Size

3. The number of components for assembly

- Parts, which are to be supplied in an assembly, are listed with a dot (.) in front of the part name as shown below.
- The numeral appearing to the right of each component part indicates the quantity of parts for each assembly unit.

PART NO.	DESCRIPTION	Q'TY	REMARKS
2F5-83310-60	FRONT FLASHER LIGHT ASSY	2	
115-83311-60	.BULB (6V-18W)	1	

4. Applicable colours of graphics are represented in the “REMARKS” as shown below.

PART NO.	DESCRIPTION	Q'TY	REMARKS
2N4-24110-00-X5	FUEL TANK COMP.	2	MXR
3J1-24240-10	.GRAPHIC, FUEL TANK	1	FOR MXR

5. Note that the illustrations for reference in finding parts numbers are not to be used for assembling. When assembling, please use the applicable service manual.

6. The asterisk (*) before a reference number indicates modified items after the first edition.

PROLOGO

Este catálogo de repuestos corresponde a las piezas para el o los modelos que figuran en la página de portada. Al formular el pedido de repuestos, se ruega citar este catálogo y especificar correctamente el número y el nombre de las piezas.

1. Las modificaciones y agregados que se hayan realizado después de la edición de este Catálogo de Repuestos, serán anunciados en las Informaciones de Recambios. Es recomendable que se hagan las correcciones necesarias en el Catálogo de Repuestos de acuerdo con las Informaciones de Recambios.

2. Abreviaciones

En este. Catálogo de Repuestos se emplean las siguientes abreviaciones.

“UR” Usar el número de partes especificado

“UN” Usar la cantidad necesaria

“AP” Piezas sustitutivas

“LM” Fabricación local (Hay que pedir los repuestos en las cercanías)

“F#” N° de bastidor (N° aplicable a la máquina)

“O/S” Sobredimensionado

3. La cantidad de componentes para el montaje

- Los componentes, suministrados como conjunto, se describen con un punto (.) que precede al nombre del parte como se indica a continuación.
- La numeración que aparece a la derecha de cada descripción indica la cantidad de partes por cada unidad de conjunto.

CODIGO N°	DESCRIPCION	CANT.	OBSERVACIONES
2F5-83310-60	ENSAMBLAJE DE LA LUZ	2	
115-83311-60	.BOMBILLA (6V-18W)	1	

4. Los colores de los componentes se indican como sigue en la columna de “OBSERVACIONES”.

CODIGO N°	DESCRIPCION	CANT.	OBSERVACIONES
2N4-24110-00-X5	COMP. DEL TANQUE	2	MXR
3J1-24240-10	.GRAFICO, DEL TANQUE	1	PARA MXR

5. Debe tenerse en cuenta que las ilustraciones sirven como guía para la búsqueda de los números de partes y no deben usarse para el montaje. Durante el montaje, se recomienda usar el manual de taller correspondiente.

6. EL asterisco (*) antes del número de referencia indica los elementos modificados después de la primera edición.

FOREWORD

7. Applicable Serial No.

Engine Serial No.

Frame Serial No.

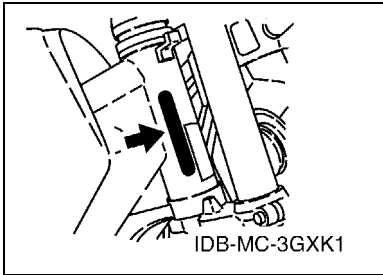
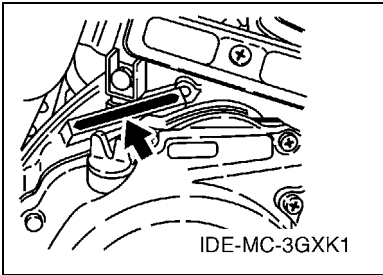

8. Applicable Colour Code (The (*) mark shows Model colour.)

Abbreviation	Colour Name	Colour Code
LGB	LOW GLOSS BLACK	0098
SBE(*)	SPACE BLUE	00J5
SL	SILVER	0035
YB	YAMAHA BLACK	0033
YNS3(*)	YELLOWISH GRAY SOLID 3	0402
ZK	*UNI-CHROME (BLACK CHROMATE)	0090

PROLOGO

7. Números de serie

Nº de Serie del motor

Nº de Serie del bastidor

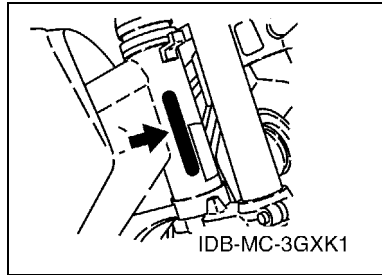
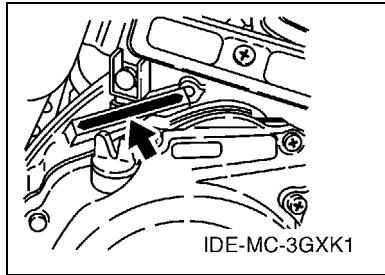

8. Códigos de color aplicables (El símbolo (*) muestra el color de modelo.)

Abreviatura	Nombre de color	Código de color
LGB	LOW GLOSS BLACK	0098
SBE(*)	SPACE BLUE	00J5
SL	SILVER	0035
YB	YAMAHA BLACK	0033
YNS3(*)	YELLOWISH GRAY SOLID 3	0402
ZK	*UNI-CHROME (BLACK CHROMATE)	0090

CONTENTS

ENGINE

CYLINDER HEAD	1
CYLINDER	3
CRANKSHAFT & PISTON	4
VALVE	6
CAMSHAFT & CHAIN	7
OIL PUMP	8
INTAKE	9
CARBURETOR	10
EXHAUST	12
CRANKCASE	13
CRANKCASE COVER 1	14
CRANKCASE COVER 2	15
STARTER	16
STARTER 2	18
CLUTCH	20
TRANSMISSION	22
SHIFT CAM & FORK	23
SHIFT SHAFT	24

CHASSIS

FRAME	25
FRAME 2	26
FENDER	27
SIDE COVER	28
REAR ARM	29
REAR SUSPENSION	31
STEERING	32
FRONT FORK	33
FUEL TANK	35
FUEL TANK 2	36
SEAT	37
FRONT WHEEL	38
FRONT WHEEL 2	40
REAR WHEEL	42
STEERING HANDLE & CABLE	44
STEERING HANDLE & CABLE 2	45
STAND & FOOTREST	46
GENERATOR	47
GENERATOR 2	48
STARTING MOTOR	49
FLASHER LIGHT	50

FLASHER LIGHT 2	51
METER	53
HEADLIGHT	54
HEADLIGHT 2	55
TAILLIGHT	56
TAILLIGHT 2	57
HANDLE SWITCH & LEVER	58
HANDLE SWITCH & LEVER 2	59
ELECTRICAL 1	60
ELECTRICAL 2	61

INDEX

NUMERICAL INDEX	63
-----------------------	----

CONTENIDO

MOTOR

CULATA DE CILINDRO	1
CILINDRO	3
CIGUENAL & PISTON	4
VALVULA	6
ARBOL DE LEVAS & CADENA	7
BOMBA DE ACEITE	8
ADMISION	9
CARBURADOR	10
DESCARGA	12
CARTER	13
CUBIERTA DE CARTER 1	14
CUBIERTA DE CARTER 2	15
ARRANQUE	16
ARRANQUE 2	18
EMBRAGUE	20
TRANSMISION	22
LEVA DE CAMBIO & HORQUILLA	23
EJE DE CAMBIO & PEDAL	24

SHASIS

CUADRO	25
CUADRO 2	26
GUARDABARRO	27
CUBIERTA LATERAL	28
BRAZO TRASERO	29
SUSPENSION TRASERO	31
DIRECCION	32
HORQUILLA DELANTERA	33
DEPOSITO DE COMBUSTIBLE	35
DEPOSITO DE COMBUSTIBLE 2	36
ASIENTO	37
RUEDA DELANTERA	38
RUEDA DELANTERA 2	40
RUEDA TRASERA	42
MANILLAR & CABLE	44
MANILLAR & CABLE 2	45
SOPORTE & APOYAPIE	46
GENERADOR	47
GENERADOR 2	48
MOTOR DE ARRANQUE	49
LUZ DE DESTELLADOR	50

LUZ DE DESTELLADOR 2	51
MEDIDOR	53
FARO DELANTERO	54
FARO DELANTERO 2	55
LUZ DE COLA	56
LUZ DE COLA 2	57
INTERRUPTOR DE MANILLAR&PALANC	58
INTERRUPTOR DE MANILLAR&PALANC	59
EQUIPO ELECTRICO 1	60
EQUIPO ELECTRICO 2	61

INDICE

INDICE NUMERICO	63
-----------------------	----

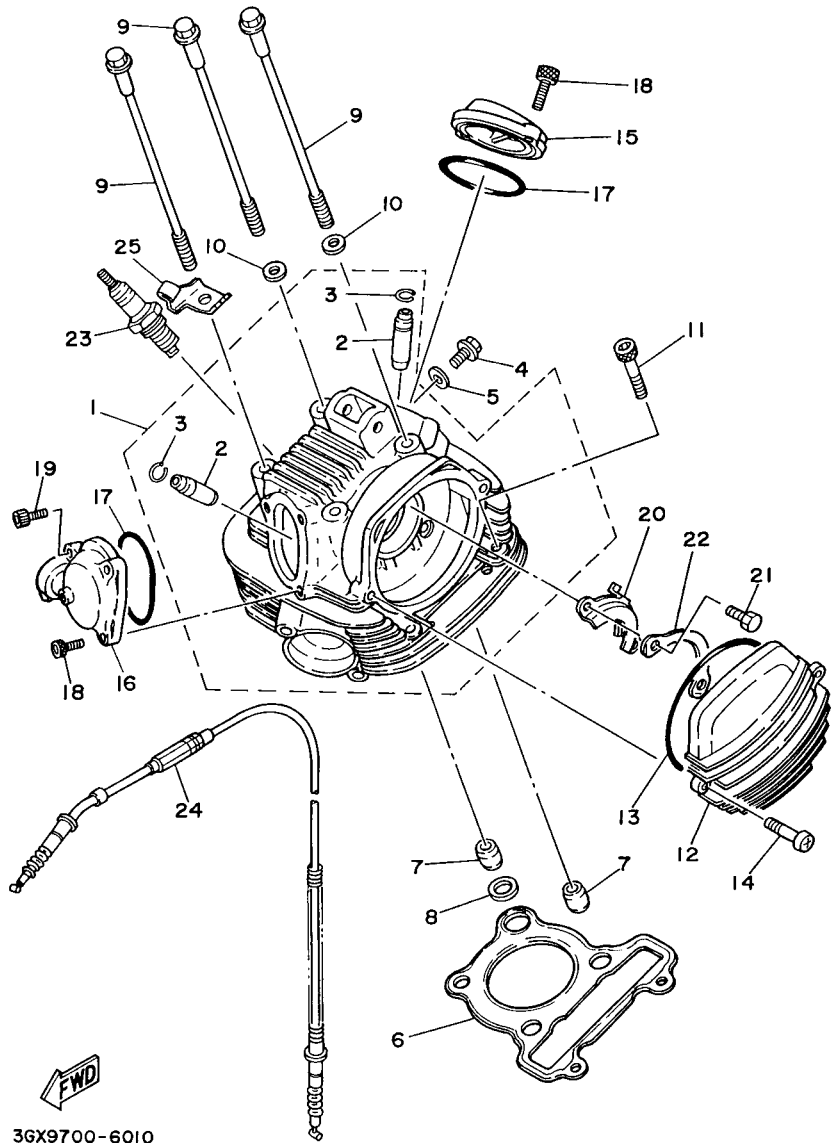

36X9700-6010

FIG. 1 CYLINDER HEAD

CULATA DE CILINDRO

REF. NO.	PART NO. CODIGO Nº	DESCRIPTION DESCRIPCION	3GXL	3GXM	3GXN	REMARKS OBSERVACIONES
1	36X-11102-04	CYLINDER HEAD ASSY CULATA DE CILINDRO COMPLETA	1	1	1	
2	5H0-11133-11	.GUIDE, VALVE 1 .GUIA DE VALVULA 1	2	2	2	
3	93440-10085	.CIRCLIP .PRESILLA REDONDA	2	2	2	
4	90153-06029	SCREW, HEXAGON TORNILLO HEXAGONAL	1	1	1	
5	90430-06014	GASKET JUNTA	1	1	1	
6	1NU-11181-00	GASKET, CYLINDER HEAD 1 JUNTA, DE CULATA 1	1	1	1	
7	99530-14016	PIN, DOWEL PASADOR, DE ESPIGA	3	3	3	
8	90430-14131	GASKET JUNTA	1	1	1	
9	90105-08195	BOLT, FLANGE TORNILLO	4	4	4	
10	90201-08609	WASHER, PLATE ARANDELA PLANA	3	3		
	90201-08609	WASHER, PLATE ARANDELA PLANA			4	
11	91317-08045	BOLT PERNO	2	2	2	
12	3RW-11185-00	COVER, CYLINDER HEAD SIDE 1 CUBIERTA CULATA CIL.LAT.1	1	1		
	4BD-11185-00	COVER, CYLINDER HEAD SIDE 1 CUBIERTA CULATA CIL.LAT.1			1	
13	93211-05471	O-RING ANILLO O	1	1	1	
14	95027-06020	BOLT, FLANGE PERNO, DE BRIDA	2	2	2	
15	5H0-11186-00	COVER, CYLINDER HEAD SIDE 2 CUBIERTA CULATA CIL.LAT.2	1	1		
	3GC-11186-00	COVER, CYLINDER HEAD SIDE 2 CUBIERTA CULATA CIL.LAT.2			1	
16	36X-11187-00	COVER, CYLINDER HEAD SIDE 3 CUBIERTA CULATA CIL.LAT.3	1	1		
	3GC-11187-00	COVER, CYLINDER HEAD SIDE 3 CUBIERTA CULATA CIL.LAT.3			1	
17	93210-57634	O-RING ANILLO O	2	2	2	
18	91317-06018	BOLT PERNO	4	4		
	91317-06018	BOLT PERNO			5	
19	90110-06064	BOLT, HEXAGON SOCKET HEAD TORNILLO ALLEN	1	1		
20	5H0-1111F-00	PLATE PLACA	1	1	1	
21	97007-06012	BOLT PERNO	2	2	2	
22	90215-06184	WASHER, LOCK ARANDELA DE CIERRE	1	1	1	

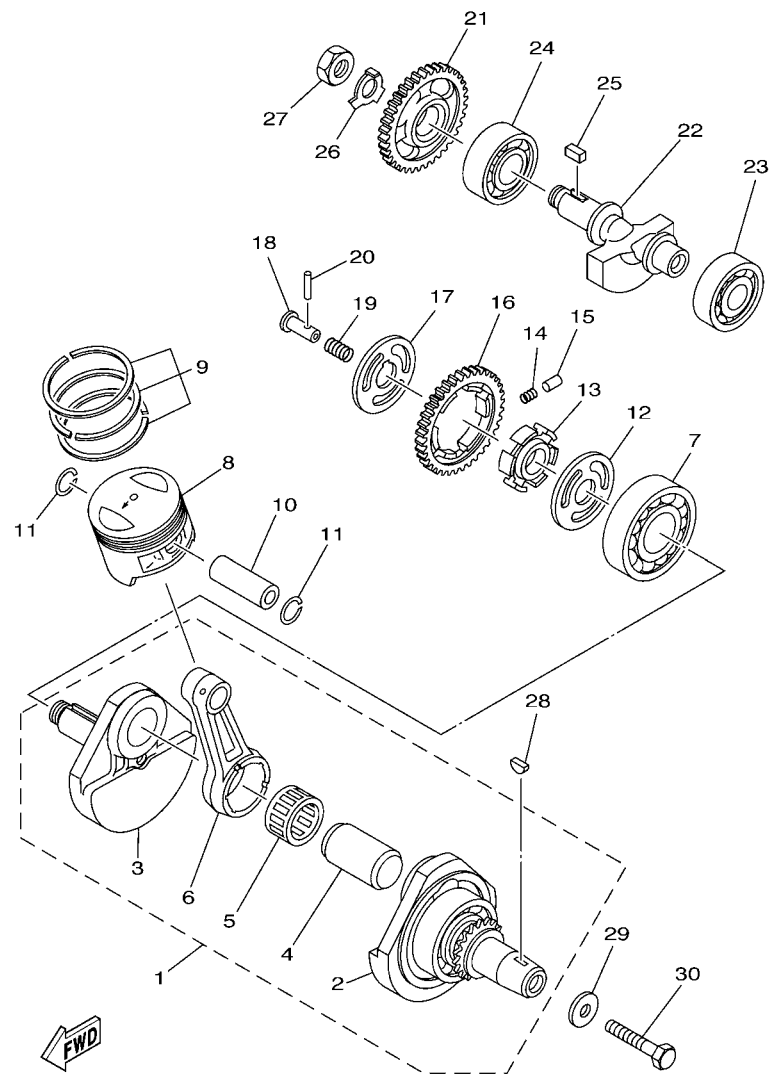

3GXG200-A030

FIG. 3 CRANKSHAFT & PISTON

CIGUENAL & PISTON

REF. NO.	PART NO. CODIGO Nº	DESCRIPTION DESCRIPCION	3GXL	3GXM	3GXN	REMARKS OBSERVACIONES
1	15A-11400-00	CRANKSHAFT ASSY CIGUENAL COMPLETO	1	1		
	5H0-11400-01	CRANKSHAFT ASSY CIGUENAL COMPLETO			1	
2	15A-11412-09	.CRANK 1 .MANIVELA 1	1	1		
	5H0-11412-09	.CRANK 1 .MANIVELA 1			1	
3	5H0-11422-00	.CRANK 2 .MANIVELA 2	1	1	1	
4	5H0-11681-00	.PIN, CRANK 1 .PASADOR MANIVELA 1	1	1	1	
5	93310-530J3	.BEARING .COJINETE DE RODILLOS	1	1	1	
6	15A-11651-00	.ROD, CONNECTING .BIELA	1	1	1	
7	93306-30611	BEARING COJINETE	1	1	1	
8	36X-11631-00-A0	PISTON (STD) PISTON (NORMA)	1	1	1	
	36X-11636-00	PISTON (0.50MM O/S) PISTON (0.50MM O/S)	1	1	1	AP AP
	36X-11638-00	PISTON (1.00MM O/S) PISTON (1.00MM O/S)	1	1	1	AP AP
9	15A-11603-00	PISTON RING SET (STD) JUEGO DE ANILLOS (NORMA)	1	1	1	
	15A-11605-00	PISTON RING SET (0.50MM O/S) JUEGO DE ANILLOS (0.50MM O/S)	1	1	1	AP AP
	15A-11607-00	PISTON RING SET (1.00MM O/S) JUEGO DE ANILLOS (1.00MM O/S)	1	1	1	AP AP
10	15A-11633-00	.PIN, PISTON PASADOR, PISTON	1	1	1	
11	93450-17044	CIRCLIP SEGURO	2	2	2	
12	90201-201E4	WASHER, PLATE ARANDELA PLANA	1	1	1	
13	5H0-11496-00	BOSS, BUFFER COPA TOPE	1	1	1	
14	90501-21133	SPRING, COMPRESSION RESORTE DE COMPRESION	6	6	6	
15	93605-10090	.PIN, DOWEL PASADOR DE CLAVIJA	3	3	3	
16	5H0-11536-00	GEAR, DRIVE (38T) ENGRANAJE TRACCION (38T)	1	1	1	
17	90214-20023	WASHER, CLAW ARANDELA DE POSICION	1	1	1	
18	90240-07083	PIN, CLEVIS PASADOR CON HOYO	1	1	1	
19	90501-07629	SPRING, COMPRESSION RESORTE DE COMPRESION	1	1	1	
20	93602-13177	.PIN, DOWEL PASADOR DE CLAVIJA	1	1	1	
21	5H0-11531-00	GEAR, BALANCE WEIGHT (38T) ENGRANAJE CONTRAPESO (38T)	1	1	1	

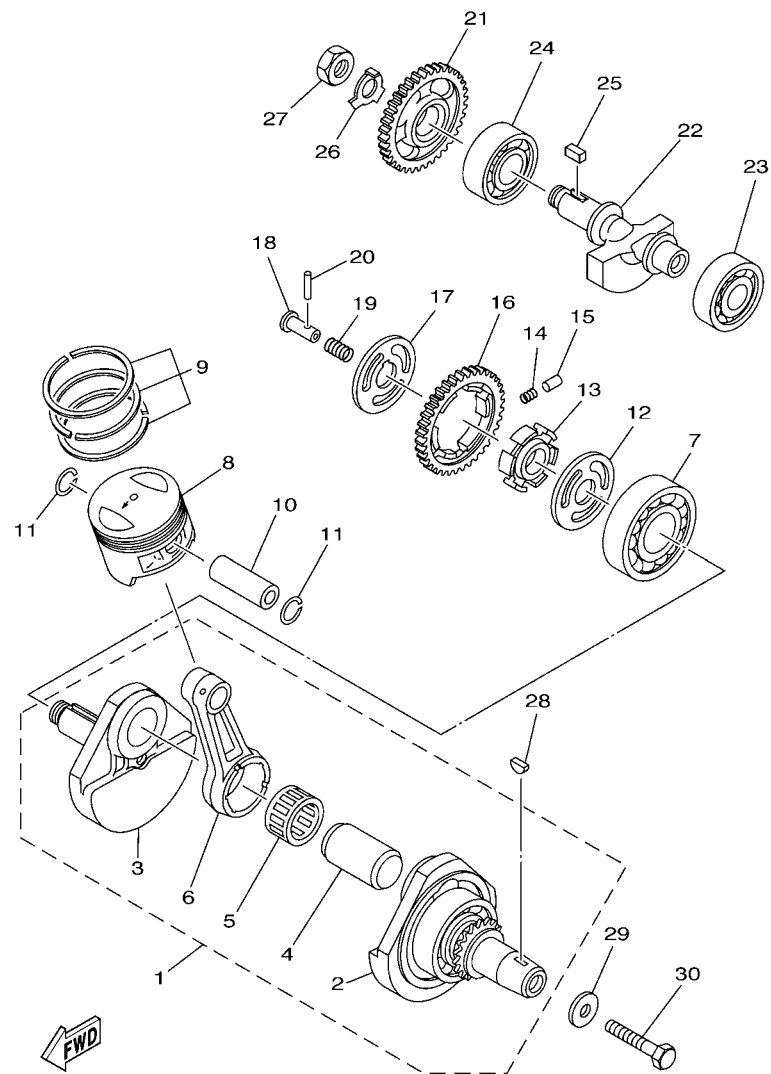

3GXG200-A030

FIG. 3 CRANKSHAFT & PISTON

CIGUENAL & PISTON

REF. NO.	PART NO. CODIGO Nº	DESCRIPTION DESCRIPCION	3GXL	3GXM	3GXN	REMARKS OBSERVACIONES
22	15A-11454-00	WEIGHT 1 PESO 1	1	1	1	
23	93306-30427	BEARING COJINETE	1	1	1	
24	93306-30427	BEARING COJINETE	1	1	1	
25	90282-05013	KEY, STRAIGHT CHAVETA, RECTA	1	1	1	
26	90215-14205	WASHER, LOCK ARANDELA DE CIERRE	1	1	1	
27	90170-14284	NUT TUERCA	1	1	1	
28	90280-05013	KEY, WOODRUFF CUNA WOODRUFF	1	1	1	
29	90201-10508	WASHER, PLATE ARANDELA PLANA	1	1	1	
30	90101-10188	BOLT TORNILLO	1	1	1	

FIG. 4 VALVE

VALVULA

REF. NO.	PART NO. CODIGO Nº	DESCRIPTION DESCRIPCION	3GXL	3GXM	3GXN	REMARKS OBSERVACIONES
1	5H0-12111-02	VALVE, INTAKE VALVULA DE ADMISION	1	1	1	
2	5H0-12121-01	VALVE, EXHAUST VALVULA DE ESCAPE	1	1	1	
3	4G0-12116-01	SEAT, VALVE SPRING ASIENTO RESORTE DE VALVULA	2	2	2	
4	4G0-12113-01	SPRING, VALVE INNER RESORTE VALVULA INTERNA	2	2	2	YELLOW AMARILLO
5	4G0-12114-01	SPRING, VALVE OUTER RESORTE VALVULA EXTERIOR	2	2	2	YELLOW AMARILLO
6	5H0-12119-00	SEAL, VALVE STEM SELLO DE ACEITE VALVULA	2	2	2	
7	4G0-12117-00	RETAINER, VALVE SPRING RETEN RESORTE DE VALVULA	2	2	2	
8	4G0-12118-00	COTTER, VALVE SEGURO DE VALVULA	4	4	4	
9	36X-12151-00	ARM, VALVE ROCKER BRAZO DE BALANCIN DE VALVULA	2	2	2	
10	5H0-12156-00	SHAFT, ROCKER 2 EJE DE BALANCIN	1	1	1	
11	5H0-12146-00	SHAFT, ROCKER ARBOL DE BALANCIN	1	1	1	
12	93210-09165	O-RING ANILLO O	1	1	1	
13	2NX-12159-00	SCREW, VALVE ADJUSTING TORNILLO DE AJUSTE DE VALVULA	2	2	2	
14	90170-06128	NUT TUERCA	2	2	2	

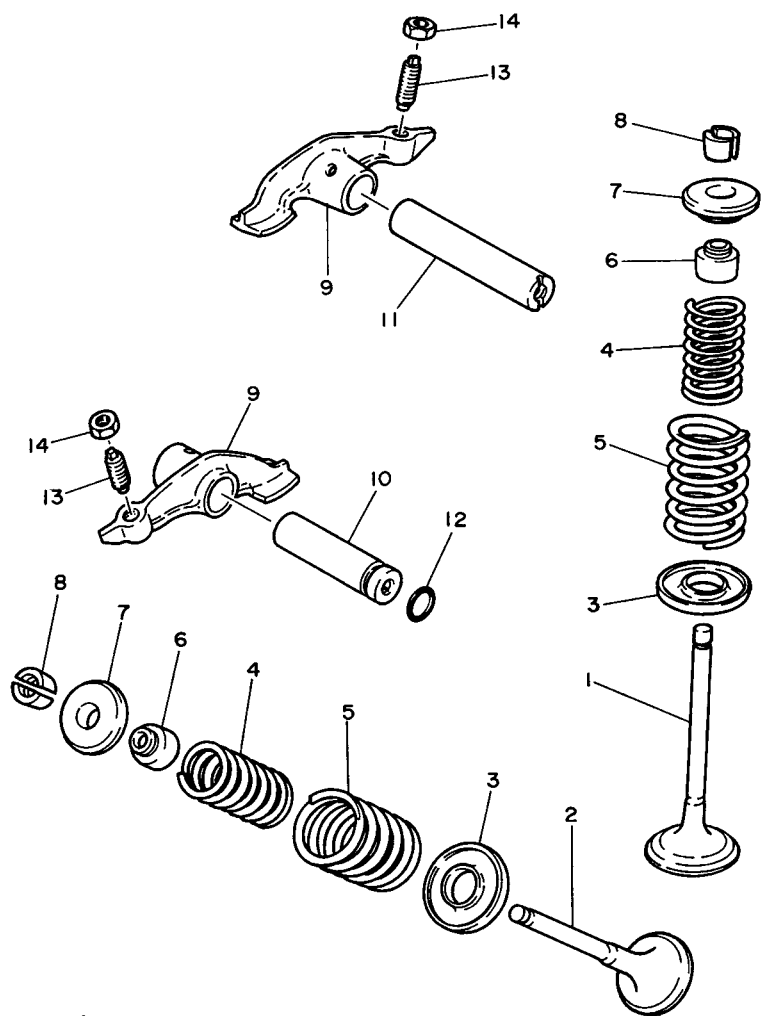

36X700-3040

FIG. 5 CAMSHAFT & CHAIN

ARBOL DE LEVAS & CADENA

REF. NO.	PART NO. CODIGO Nº	DESCRIPTION DESCRIPCION	3GXL	3GXM	3GXN	REMARKS OBSERVACIONES
1	36X-12171-00	CAMSHAFT 1 ARBOL DE LEVAS 1	1	1	1	
2	5H0-12176-00	SPROCKET, CAM CHAIN (40T) CATALINA DE CADENA (40T)	1	1	1	
3	93604-10011	PIN, DOWEL PASADOR DE CLAVIJA	1	1	1	
4	90101-10303	BOLT TORNILLO	1	1	1	
5	90201-10591	WASHER, PLATE ARANDELA PLANA	1	1	1	
6	90387-255F3	COLLAR COLLAR	1	1	1	
7	94580-41104	CHAIN (DID25SH 104L) CADENA (DID25SH 104L)	1	1	1	
8	5H0-12231-00	GUIDE, STOPPER 1 TOPE DE GUIA 1	1	1	1	
9	5N0-12241-00	GUIDE, STOPPER 2 TOPE DE GUIA 2	1	1	1	
10	3GC-12210-10	TENSIONER ASSY, CAM CHAIN TENSOR CADENA DE LEVA	1	1	1	
11	4FM-12213-00	GASKET, TENSIONER CASE EMPAQUE DE CAJA TENSOR	1	1	1	
12	91317-06025	BOLT PERNO	2	2	2	
13	97027-06016	BOLT PERNO	2	2	2	
14	92907-06600	WASHER, PLATE ARANDELA	2	2	2	
15	36X-12288-01	CAM, DECOMPRESSION LEVA DE DESCOMPRESION	1	1		
16	90508-16428	SPRING, TORSION RESORTE DE TORSION	1	1		
17	93102-12321	OIL SEAL SELLO ACEITE	1	1		
18	90201-12588	WASHER, PLATE ARANDELA PLANA	1	1		
19	90109-06418	BOLT PERNO	1	1		
20	90430-06014	GASKET JUNTA	1	1		

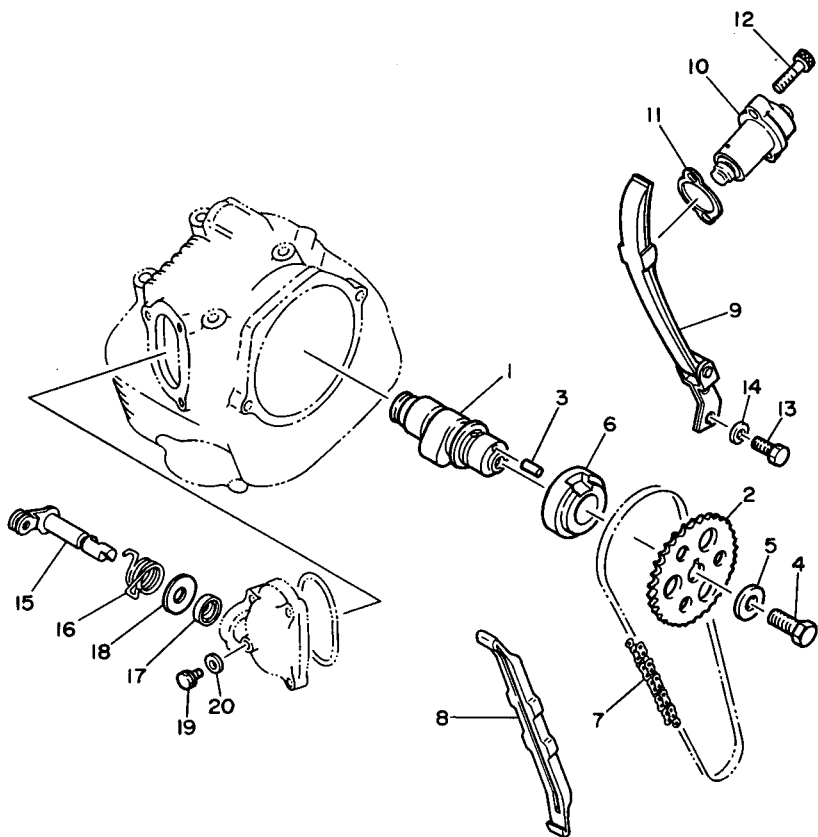

3GX700-8050

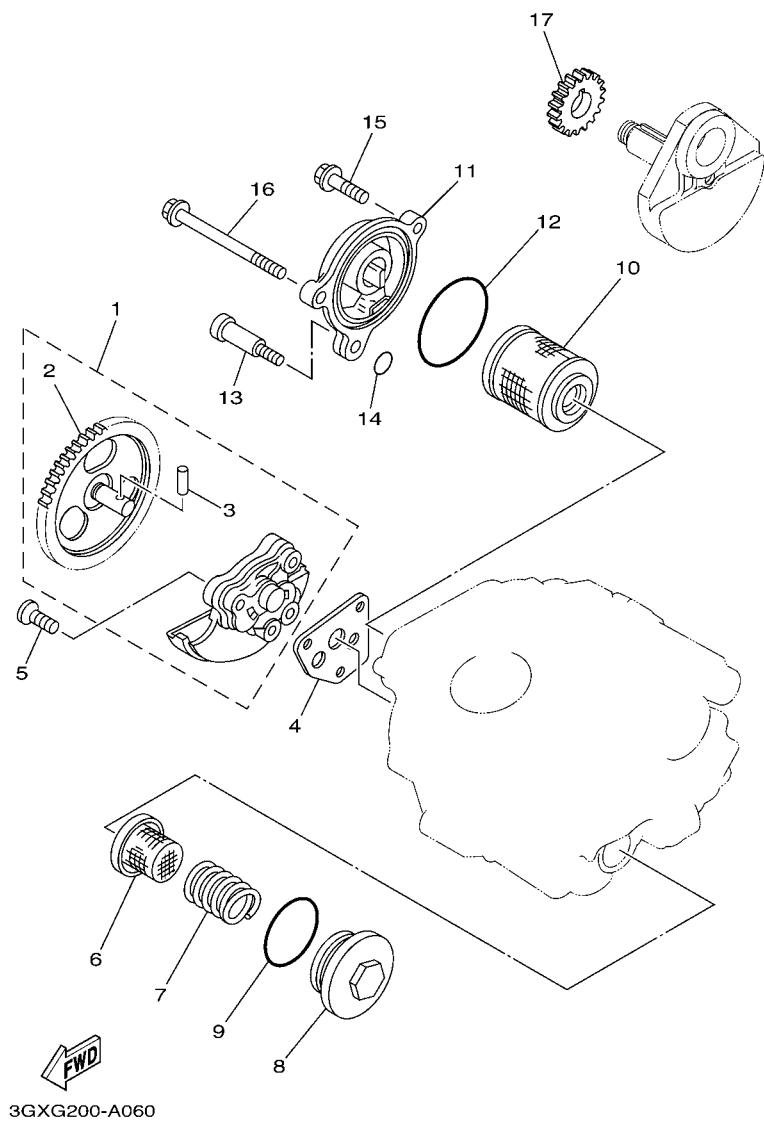
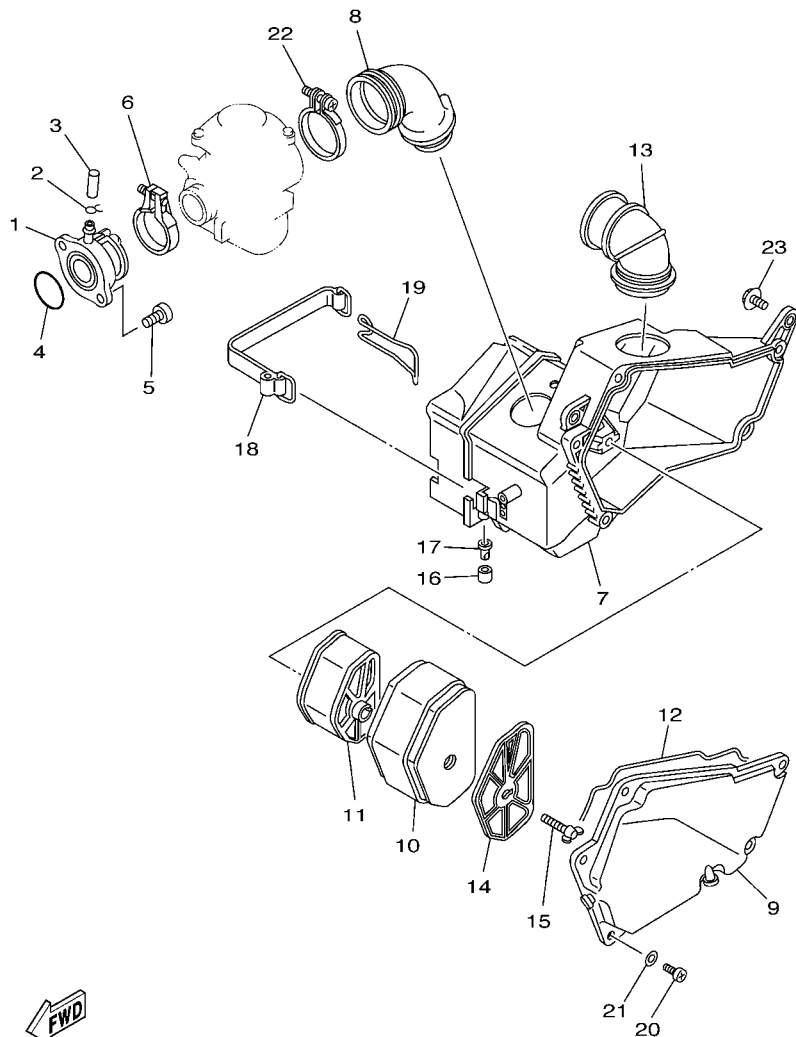

FIG. 6 OIL PUMP

BOMBA DE ACEITE

REF. NO.	PART NO. CODIGO Nº	DESCRIPTION DESCRIPCION	3GXL	3GXM	3GXN	REMARKS OBSERVACIONES
1	5H0-13300-02	OIL PUMP ASSY BOMBA DE ACEITE COMPLETA	1	1	1	
2	5H0-13326-01	.GEAR, PUMP DRIVEN 2 (45T) .ENGRANAJE IMPULSOR (45T)	1	1	1	
3	93603-12030	.PIN, DOWEL .PASADOR DE CLAVIJA	1	1	1	
4	4BE-13329-01	GASKET, PUMP COVER EMPAQUE TAPA DE BOMBA	1	1	1	
5	98707-06030	SCREW, FLAT HEAD TORNILLO DE CABEZA PLANA	3	3	3	
6	51Y-13411-00	STRAINER, OIL FILTRO DE ACEITE	1	1	1	
7	90501-18576	SPRING, COMPRESSION RESORTE DE COMPRESION	1	1	1	
8	5H0-15351-00	PLUG, DRAIN TAPON DE DRENAJE	1	1	1	
9	93210-347A1	O-RING ANILLO O	1	1	1	
10	5H0-13440-00	ELEMENT ASSY, OIL CLEANER ELEMENTO FILTRO DE ACEITE	1	1	1	
11	3GX-13447-00	COVER, OIL ELEMENT TAPA DEL ELEMENTO	1	1	1	
12	93210-54175	O-RING ANILLO O	1	1	1	
13	90109-06419	BOLT PERNO	1	1	1	
14	93210-07135	O-RING ANILLO O	1	1	1	
15	95027-06025	BOLT, FLANGE PERNO, DE BRIDA	1	1	1	
16	90105-065A1	BOLT, FLANGE TORNILLO	1	1	1	
17	36X-13324-00	GEAR, PUMP DRIVE (22T) ENGRANAJE TRACC.DE BOMBA(22T)	1	1	1	



3GXF700-B070



FIG. 7 INTAKE

ADMISION

REF. NO.	PART NO. CODIGO Nº	DESCRIPTION DESCRIPCION	3GXL	3GXM	3GXN	REMARKS OBSERVACIONES
1	36X-13586-01	JOINT, CARBURETOR 1 TOBERA DE CARBURADOR 1	1	1	1	
2	90467-10035	CLIP PRESILLA	1	1		
	90467-10039	CLIP PRESILLA			1	
3	16G-13569-00	PLUG, BLIND TAPON CIEGO	1	1	1	
4	93210-35537	O-RING ANILLO O	1	1	1	
5	91317-06020	BOLT PERNO	2	2	2	
6	1HX-13575-00	BAND BANDA	1	1	1	
7	36X-14401-00	AIR CLEANER CASE ASSY CAJA DE FILTRO DE AIRE COMPL.	1	1		
	3GX-14401-00	AIR CLEANER CASE ASSY CAJA DE FILTRO DE AIRE COMPL.			1	
8	36X-14453-01	JOINT, AIR CLEANER 1 UNION DEL FILTRO DEL AIRE 1	1	1	1	
9	36X-14412-00	CAP, CLEANER CASE 1 TAPA CAJA DEL FILTRO 1	1	1	1	
10	36X-14451-00	ELEMENT, AIR CLEANER ELEMENTO DEL FILTRO DEL AIRE	1	1	1	
11	36X-14458-00	GUIDE GUIA	1	1	1	
12	36X-14452-00	SEAL SELLO	1	1	1	
13	36X-14437-00	DUCT CONDUCTO	1	1	1	
14	36X-14468-00	PLATE, ELEMENT FITTING PLACA ACCESORIO DE ELEMENTO	1	1	1	
15	90122-06012	BOLT, WING PERNO MARIPOSA	1	1	1	
16	90387-051K7	COLLAR COLLAR	1	1	1	
17	24W-13512-00	VALVE, ROTARY VALVULA ROTATORIA	1	1	1	
18	3GX-82131-00	BAND, BATTERY TIRANTE DE BATERIA			1	
19	3GX-82124-00	BAND, BATTERY BANDA DE BATERIA			1	
20	98507-05016	SCREW, PAN HEAD TORNILLO DE CABEZA PLANA	5	5	5	
21	92907-05600	WASHER, PLATE ARANDELA	5	5	5	
22	90460-56105	CLAMP, HOSE BRIDA, DE UNION	1	1	1	
23	95807-06016	BOLT, FLANGE TUERCA DE REBORDE	2	2	2	

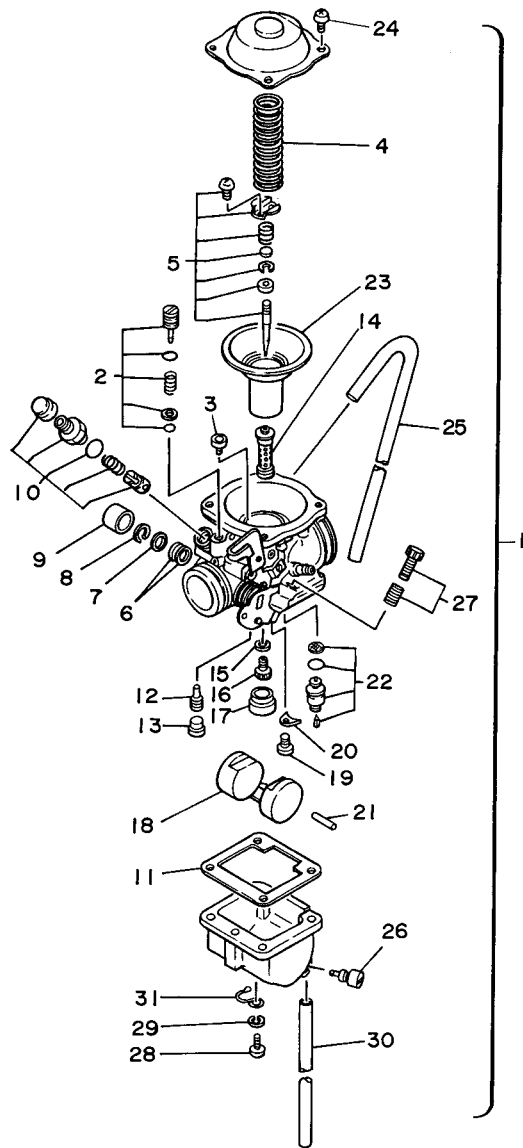

FWD
36X700-3080

FIG. 8 CARBURETOR

CARBURADOR

REF. NO.	PART NO. CODIGO Nº	DESCRIPTION DESCRIPCION	3GX	3XM	3XN	REMARKS OBSERVACIONES
1	36X-14901-01	CARBURETOR ASSY 1 CARBURADOR COMPLETO 1	1	1	1	
2	36X-14105-00	.PILOT SCREW SET .TORNILLO DE PILOTO	1	1	1	
3	3G2-14231-25	.JET, MAIN (#125) .INYECTOR, PRINCIPAL (#125)	1	1	1	
4	36X-14933-01	.SPRING, DIAPHRAGM .RESORTE DE DIAFRAGMA	1	1	1	
5	36X-1490J-00	.NEEDLE SET .CJTO. AGUJA	1	1	1	
6	256-14997-00	.SEAL .SELLO	2	2	2	
7	22F-14126-00	.GASKET .EMPAQUE	1	1	1	
8	812-14137-00	.CLIP .PRESILLA	1	1	1	
9	36X-14169-00	.CAP .FUNDA	1	1	1	
10	36X-1410A-00	.STARTER SET .JUEGO DE ARRANQUE	1	1	1	
11	46X-14984-00	.GASKET, FLOAT CHAMBER .EMPAQUE CAMARA DE BOIA	1	1	1	
12	4G0-14142-35	.JET, PILOT (# 35) .SURTIDOR DE RALENTI (# 35)	1	1	1	
13	3F7-14991-00	.PLUG, SCREW .TAPON DE TORNILLO	1	1	1	
14	36X-14941-42	.NOZZLE, MAIN .BOQUILLA PRINCIPAL	1	1	1	
15	137-14153-00	.WASHER, MAIN JET .ARANDELA SURTIDOR PPAL.	1	1	1	
16	620-14231-74	.JET, MAIN (#117.5) .INYECTOR, PRINCIPAL (#117.5)	1	1	1	
17	36X-14153-00	.WASHER, MAIN JET .ARANDELA SURTIDOR PPAL.	1	1	1	
18	4G0-14985-00	.FLOAT .BOIA	1	1	1	
19	97802-04006	.SCREW, PAN HEAD .TORNILLO	1	1	1	
20	36X-14146-00	.PLATE .PLACA SOPORTE	1	1	1	
21	537-14186-00	.PIN, FLOAT .PASADOR DE LA BOYA	1	1	1	
22	25G-14107-20	.NEEDLE VALVE SET .VALVULA DE AGUJA	1	1	1	
23	36X-14940-00	.DIAPHRAGM ASSY .DIAFRAGMA COMPLETO	1	1	1	
24	97802-05008	.SCREW, PAN HEAD .TORNILLO	4	4	4	
25	36X-14197-00	.PIPE .TUBO RESPIRADERO	1	1	1	
26	36X-14191-00	.PLUG, DRAIN .TORNILLO, DE DRENAJE	1	1	1	
27	36X-1490K-00	.STOP SCREW SET .JUEGO DE TORNILLOS DE TOPE	1	1	1	

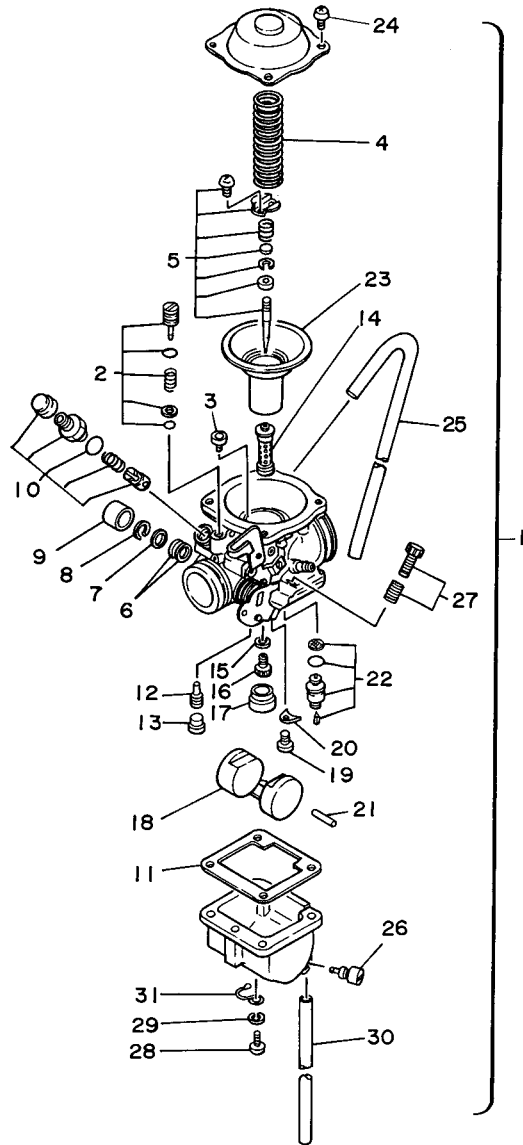

36X700-3080

FIG. 8 CARBURETOR

CARBURADOR

REF. NO.	PART NO. CODIGO Nº	DESCRIPTION DESCRIPCION	3GXL	3GXM	3GXN	REMARKS OBSERVACIONES
28	98502-04014	.SCREW, PAN HEAD .TORNILLO	4	4	4	
29	92902-04100	.WASHER, SPRING .RONDANA SENCILLA	4	4	4	
30	21V-14196-00	.PIPE .TUBO DE DRENASE	1	1	1	
31	25G-14937-00	.CLIP .PRESILLA	1	1	1	

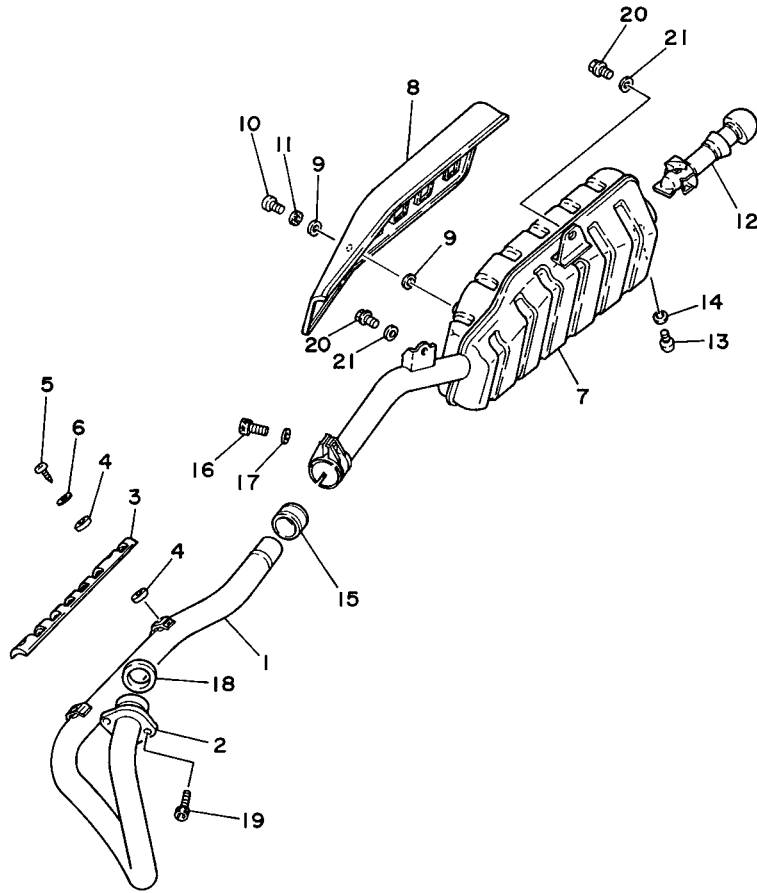

3GX700-8090

FIG. 9 EXHAUST

DESCARGA

REF. NO.	PART NO. CODIGO Nº	DESCRIPTION DESCRIPCION	3GXL	3GXM	3GXN	REMARKS OBSERVACIONES
1	36X-14611-01	PIPE, EXHAUST 1 TUBO DE ESCAPE 1	1	1		
	3GX-14611-00	PIPE, EXHAUST 1 TUBO DE ESCAPE 1			1	
2	5H0-14612-01	NUT, RING TUERCA ANILLO	1	1	1	
3	36X-14628-01	PROTECTOR, EXHAUST PIPE PROTECTOR DE TUBO DE ESCAPE	1	1	1	
4	4BD-14766-00	WASHER, PROTECTOR ARANDELA DE PROTECTOR	4	4	4	
5	98907-06010	SCREW, BIND TORNILLO DE LIGAR	2	2	2	
6	90206-06090	WASHER, WAVE ARANDELA ONDULADA	2	2	2	
7	36X-14711-01	MUFFLER 1 SILENCIADOR 1	1	1	1	
8	36X-14728-00	PROTECTOR, MUFFLER 2 PROTECTOR DE SILENCIADOR	1	1	1	
9	4BD-14766-00	WASHER, PROTECTOR ARANDELA DE PROTECTOR	4	4	4	
10	98907-06010	SCREW, BIND TORNILLO DE LIGAR	2	2	2	
11	90206-06090	WASHER, WAVE ARANDELA ONDULADA	2	2	2	
12	36X-14752-02	PIPE, OUTLET TUBO BOCA DE SALIDA	1	1	1	
13	98507-06010	SCREW, PAN HEAD TORNILLO DE CABEZA PLANA	1	1	1	
14	92907-06600	WASHER, PLATE ARANDELA	1	1	1	
15	3YF-14714-00	GASKET, MUFFLER EMPAQUE DE SILENCIADOR	1	1	1	
16	91317-08025	BOLT PERNO	1	1	1	
17	92907-08600	WASHER, PLATE ARANDELA	1	1	1	
18	4BE-14613-00	GASKET, EXHAUST PIPE JUNTA, TUBO DE ESCAPE	1	1	1	
19	91317-06020	BOLT PERNO	2	2	2	
20	90105-08141	BOLT, FLANGE TORNILLO	2	2	2	
21	90201-08326	WASHER, PLATE ARANDELA PLANA	2	2	2	

FIG. 10 CRANKCASE

CARTER

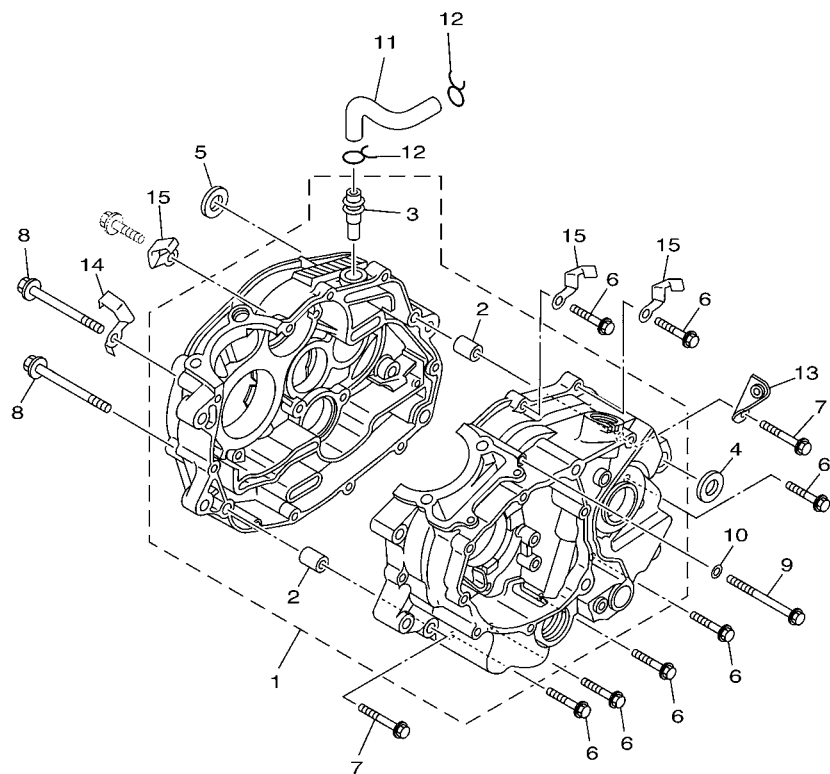

REF. NO.	PART NO. CODIGO Nº	DESCRIPTION DESCRIPCION	3GXL	3GXM	3GXN	REMARKS OBSERVACIONES
1	36X-15100-02	CRANKCASE ASSY CARTER COMPLETO	1	1		
	3GX-15100-02	CRANKCASE ASSY CARTER COMPLETO			1	
2	99530-12016	.PIN, DOWEL .PASADOR, DE ESPIGA	2	2	2	
3	371-11167-01	.PIPE, BREATHER 2 .CUBIERTA RESPIRADERO 2	1	1	1	
4	90387-125F1	COLLAR COLLAR	1	1	1	
5	90387-125F1	COLLAR COLLAR	1	1	1	
6	95027-06030	BOLT, FLANGE PERNO, DE BRIDA	7	7	7	
7	95027-06040	BOLT, FLANGE PERNO, DE BRIDA	2	2	2	
8	95027-06080	BOLT, FLANGE PERNO, DE BRIDA	2	2		
	95027-06090	BOLT, FLANGE PERNO, DE BRIDA			2	
9	95027-06085	BOLT, FLANGE PERNO, DE BRIDA	1	1	1	
10	90430-06014	GASKET JUNTA	1	1	1	
11	36X-11166-00	PIPE, BREATHER 1 TUBO RESPIRADERO 1	1	1	1	
12	90467-14015	CLIP PRESILLA	2	2	2	
13	90465-08020	CLAMP BRIDA	1	1	1	
14	90462-08224	CLAMP BRIDA			1	
15	90462-08225	CLAMP BRIDA			3	

3GXF700-B101

FIG. 11 CRANKCASE COVER 1

CUBIERTA DE CARTER 1

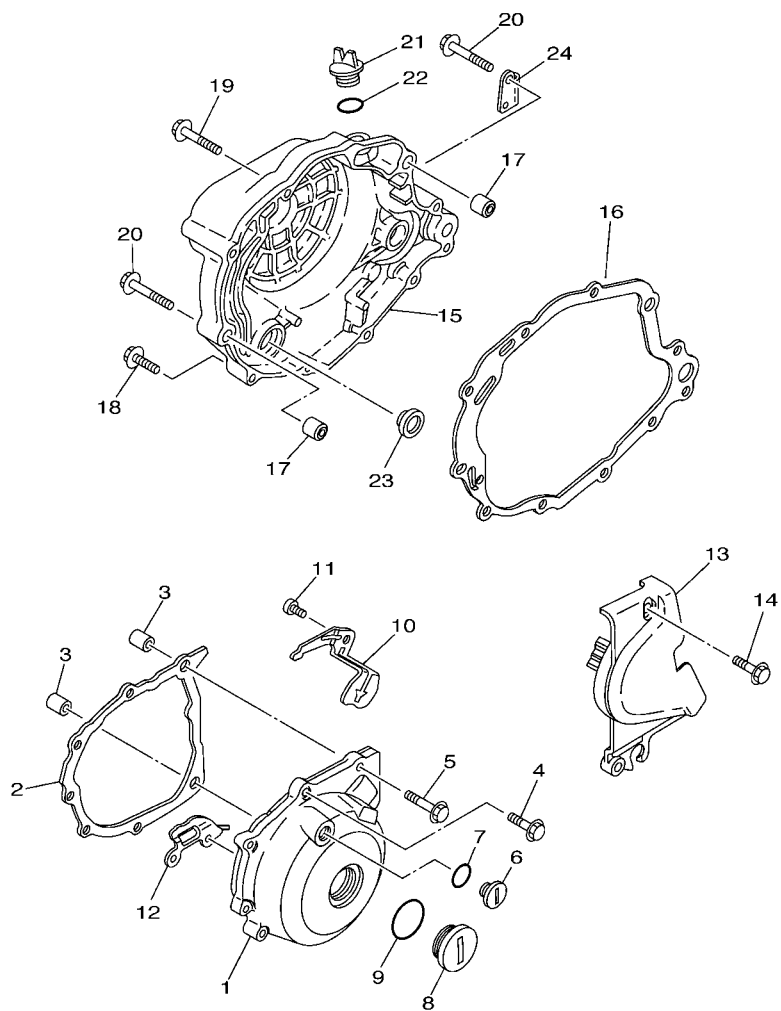

3GXG200-A110

REF. NO.	PART NO. CODIGO Nº	DESCRIPTION DESCRIPCION	3GXL	3GXM	3GXN	REMARKS OBSERVACIONES
1	36X-15411-00	COVER, CRANKCASE 1 CUBIERTA DE CARTER 1	1	1		
2	15A-15451-02	GASKET, CRANKCASE COVER 1 EMPAQ DE CUBIERTA DE CARTER	1	1		
3	99530-12016	PIN, DOWEL PASADOR, DE ESPIGA	2	2		
4	95027-06025	BOLT, FLANGE PERNO, DE BRIDA	2	2		
5	95027-06035	BOLT, FLANGE PERNO, DE BRIDA	2	2		
6	90340-14068	PLUG, STRAIGHT SCREW TORNILLO, DE DRENAJE	1	1		
7	93210-14369	O-RING ANILLO O	1	1		
8	90340-32116	PLUG, STRAIGHT SCREW TORNILLO, DE DRENAJE	1	1		
9	93210-32172	O-RING ANILLO O	1	1		
10	90465-08188	CLAMP BRIDA	1	1		
11	98507-06010	SCREW, PAN HEAD TORNILLO DE CABEZA PLANA	1	1		
12	90465-16187	CLAMP BRIDA	1	1		
13	36X-15421-01	COVER, CRANKCASE 2 TAPA DE CARTER DERECHA	1	1		
14	95027-06025	BOLT, FLANGE PERNO, DE BRIDA	2	2		
15	36X-15431-01	COVER, CRANKCASE 3 CUBIERTA DE CARTER 3	1	1		
16	4BE-15462-00	GASKET, CRANKCASE COVER 3 EMPAQ CUBIERTA DE CARTER 3	1	1		
17	99530-12016	PIN, DOWEL PASADOR, DE ESPIGA	2	2		
18	95027-06025	BOLT, FLANGE PERNO, DE BRIDA	2	2		
19	95027-06035	BOLT, FLANGE PERNO, DE BRIDA	2	2		
20	95027-06045	BOLT, FLANGE PERNO, DE BRIDA	2	2		
21	3Y1-15363-00	PLUG, OIL TAPON DE ACEITE	1	1		
22	93210-19123	O-RING ANILLO O	1	1		
23	3Y1-15361-00	GAUGE, LEVEL MEDIDOR DE NIVEL	1	1		
24	36X-15378-00	HOLDER SOPORTE	1	1		

FIG. 12 CRANKCASE COVER 2

CUBIERTA DE CARTER 2

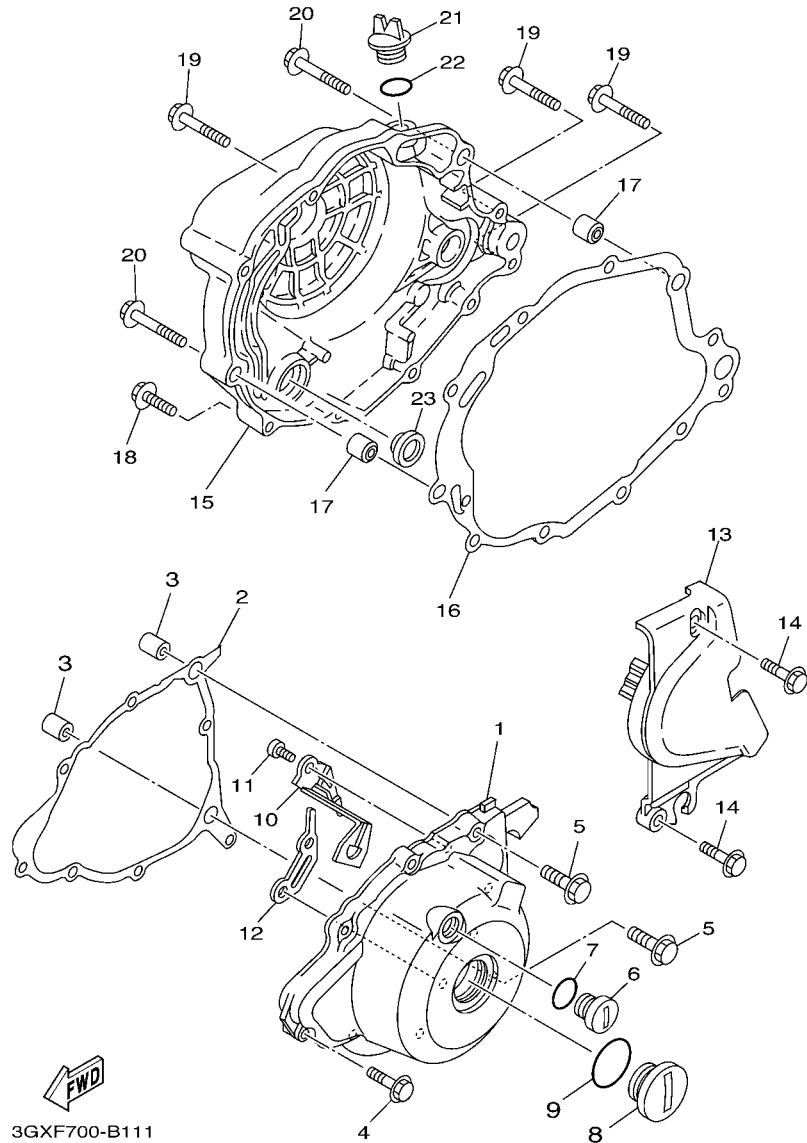

3GX700-B111

REF. NO.	PART NO. CODIGO Nº	DESCRIPTION DESCRIPCION	3GXL	3GXM	3GXN	REMARKS OBSERVACIONES
1	4WP-15411-02	COVER, CRANKCASE 1 CUBIERTA DE CARTER 1			1	
2	4BE-15451-03	GASKET, CRANKCASE COVER 1 EMPAQ DE CUBIERTA DE CARTER			1	
3	99530-12016	PIN, DOWEL PASADOR, DE ESPIGA			2	
4	95027-06025	BOLT, FLANGE PERNO, DE BRIDA			6	
5	95027-06035	BOLT, FLANGE PERNO, DE BRIDA			2	
6	90340-14068	PLUG, STRAIGHT SCREW TORNILLO, DE DRENAJE			1	
7	93210-14369	O-RING ANILLO O			1	
8	90340-32116	PLUG, STRAIGHT SCREW TORNILLO, DE DRENAJE			1	
9	93210-32172	O-RING ANILLO O			1	
10	90465-08364	CLAMP BRIDA			1	
11	91317-06010	BOLT PERNO			1	
12	90462-16213	CLAMP BRIDA			1	
13	36X-15421-01	COVER, CRANKCASE 2 TAPA DE CARTER DERECHA			1	
14	95027-06025	BOLT, FLANGE PERNO, DE BRIDA			2	
15	3GX-15431-00	COVER, CRANKCASE 3 CUBIERTA DE CARTER 3			1	
16	4BE-15462-00	GASKET, CRANKCASE COVER 3 EMPAQ CUBIERTA DE CARTER 3			1	
17	99530-12016	PIN, DOWEL PASADOR, DE ESPIGA			2	
18	95027-06025	BOLT, FLANGE PERNO, DE BRIDA			5	
19	95027-06035	BOLT, FLANGE PERNO, DE BRIDA			3	
20	95027-06045	BOLT, FLANGE PERNO, DE BRIDA			2	
21	3Y1-15363-00	PLUG, OIL TAPON DE ACEITE			1	
22	93210-19123	O-RING ANILLO O			1	
23	3Y1-15361-00	GAUGE, LEVEL MEDIDOR DE NIVEL			1	

FIG. 13 STARTER

ARRANQUE

REF. NO.	PART NO. CODIGO Nº	DESCRIPTION DESCRIPCION	3GXL	3GXM	3GXN	REMARKS OBSERVACIONES
1	36X-15660-01	KICK AXLE ASSY EJE DEL PEDAL DE ARRAN.COMPLET	1	1		
2	90468-26122	CLIP PRESILLA	1	1		
3	401-15676-00	COVER, SPRING CUBIERTA DE RESORTE	1	1		
4	15A-15666-00	SPACER SEPARADOR	1	1		
5	90508-26538	SPRING, TORSION RESORTE DE TORSION	1	1		
6	99009-17400	CIRCLIP PRESILLA REDONDA	1	1		
7	90201-175F6	WASHER, PLATE ARANDELA PLANA	1	1		
8	36X-15641-00	GEAR, KICK (27T) ENGRANAJE PEDAL ARRANQUE(27T)	1	1		
9	90209-17226	WASHER ARANDELA DE SEPARACION	1	1		
10	93102-17263	OIL SEAL SELLO ACEITE	1	1		
11	90201-173F4	WASHER, PLATE ARANDELA PLANA	1	1		
12	15A-15651-01	GEAR, KICK IDLE (28T) PINON, LIBRE (28T)	1	1		
13	90214-17028	WASHER, CLAW ARANDELA DE POSICION	1	1		
14	99009-17400	CIRCLIP PRESILLA REDONDA	2	2		
15	36X-15620-01	KICK CRANK ASSY MANIVELA DE PEDAL COMPLETA	1	1		
16	36X-15621-02	.BOSS, KICK CRANK .COPA DE MANIVELA DE PEDAL	1	1		
17	90501-12081	.SPRING, COMPRESSION .RESORTE DE COMPRESION	1	1		
18	93507-32009	.BALL .ESFERA	1	1		
19	90152-06010	.SCREW, COUNTERSUNK .TORNILLO EMBUTIDO	1	1		
20	97027-08030	BOLT PERNO	1	1		
21	36X-1561A-00	DECOMP. LEVER ASSY PALANCA DE DESCOMPRESION COMPL	1	1		
22	99009-10400	.CIRCLIP .PRESILLA REDONDA	1	1		
23	90201-10644	WASHER, PLATE ARANDELA PLANA	1	1		
24	93102-10207	OIL SEAL (SD 10-21-5 HS) SELLO, ACEITE (SD 10-21-5 HS)	1	1		
25	90201-10135	WASHER, PLATE ARANDELA PLANA	1	1		
26	90508-14620	SPRING, TORSION RESORTE DE TORSION	1	1		
27	36X-1561G-00	LEVER, CABLE PALANCA DE CABLE	1	1		

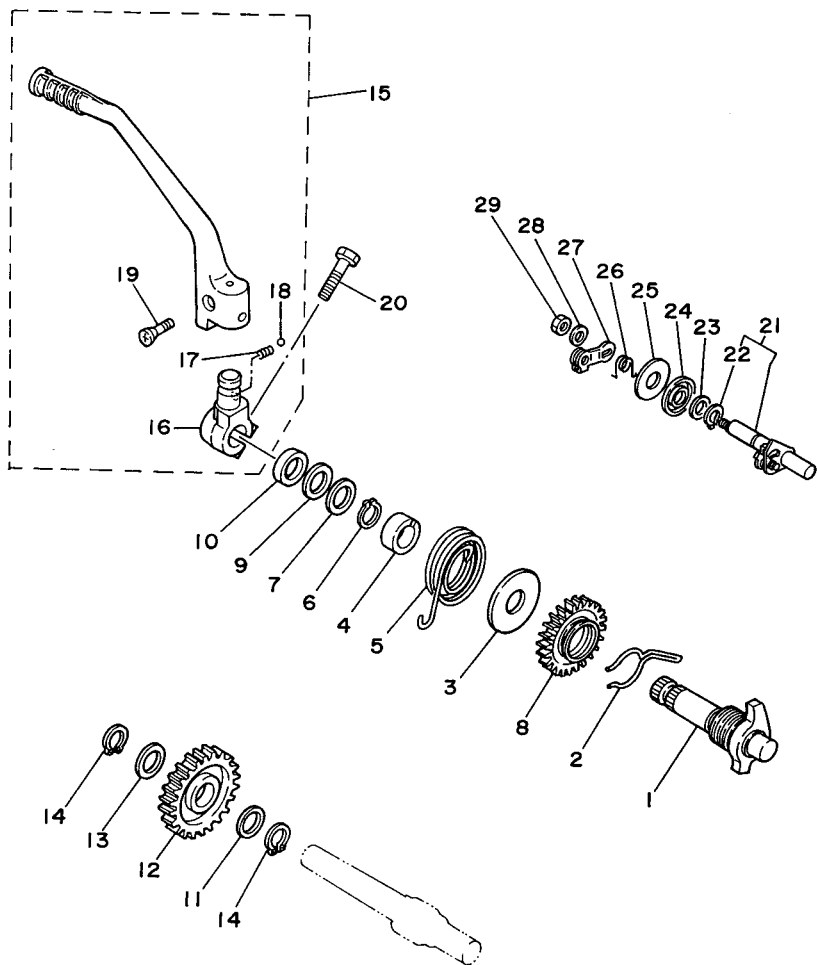

FWD
36X700-3120

FIG. 13 STARTER

ARRANQUE

REF. NO.	PART NO. CODIGO Nº	DESCRIPTION DESCRIPCION	3GXL	3GXM	3GXN	REMARKS OBSERVACIONES
28	92907-06600	WASHER, PLATE ARANDELA	1	1		
29	95317-06700	NUT TUERCA	1	1		

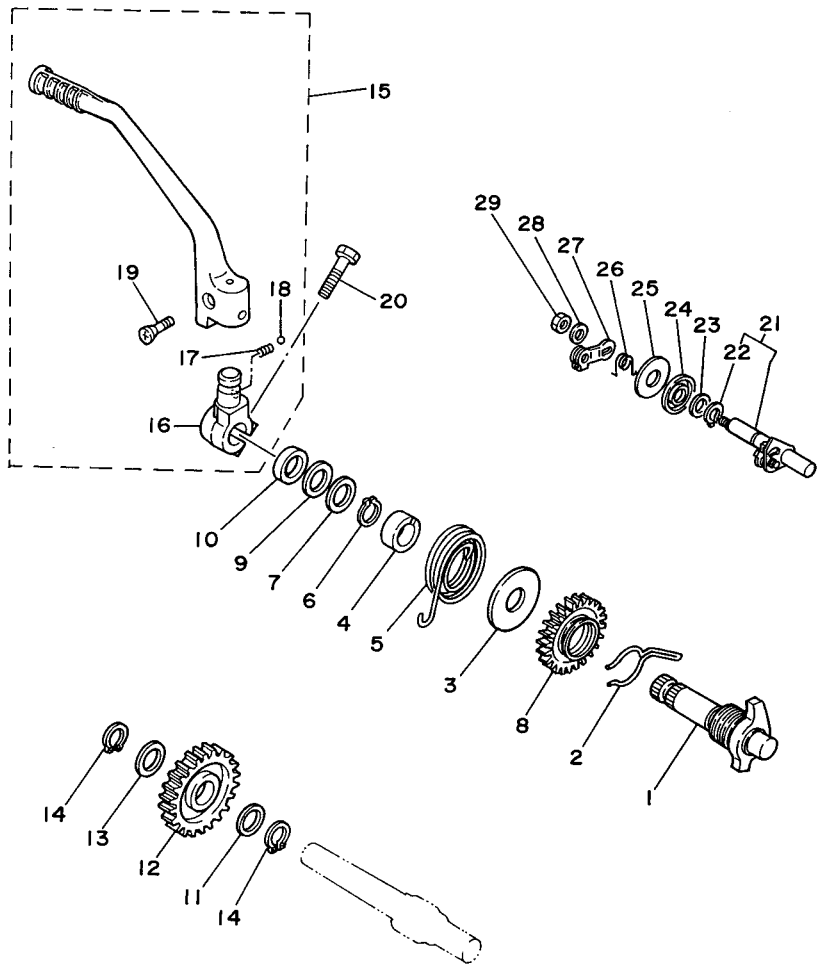

36X700-3120

FIG. 14 STARTER 2

ARRANQUE 2

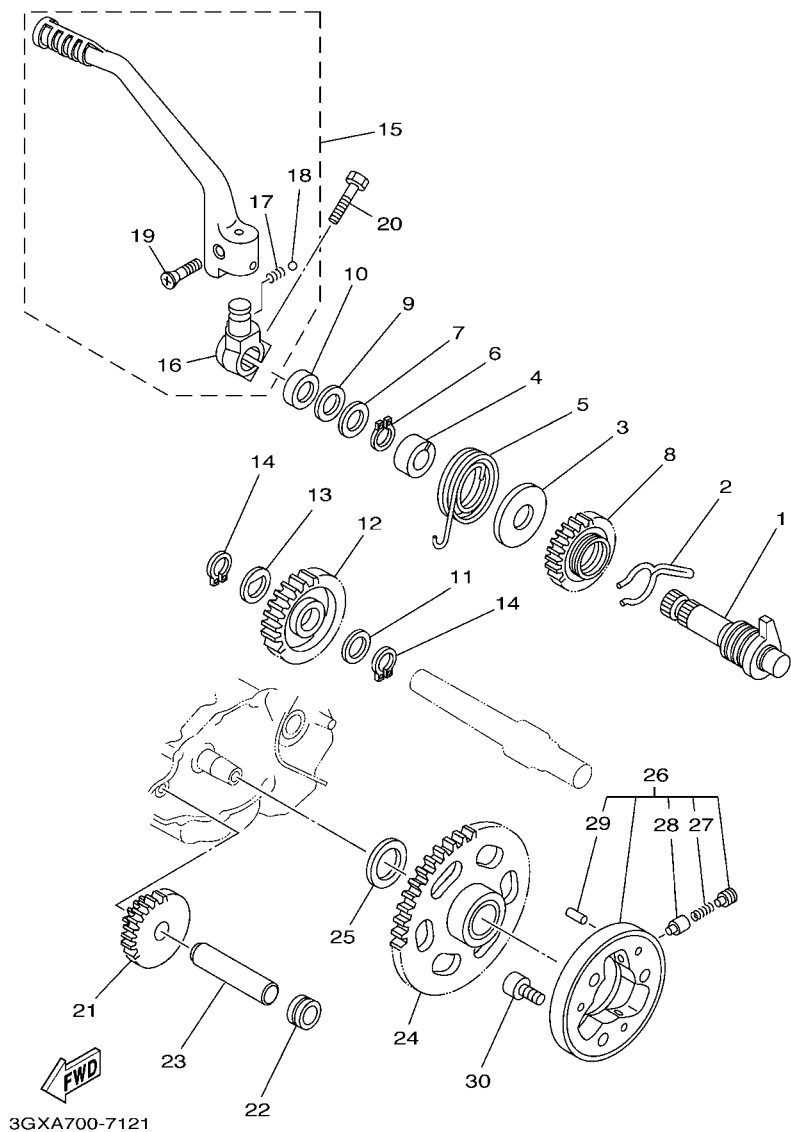

3GXA700-7121

REF. NO.	PART NO. CODIGO N°	DESCRIPTION DESCRIPCION	3GXL	3GXM	3GXN	REMARKS OBSERVACIONES
1	36X-15660-01	KICK AXLE ASSY EJE DEL PEDAL DE ARRAN.COMPLET			1	
2	90468-26122	CLIP PRESILLA			1	
3	401-15676-00	COVER, SPRING CUBIERTA DE RESORTE			1	
4	15A-15666-00	SPACER SEPARADOR			1	
5	90508-26538	SPRING, TORSION RESORTE DE TORSION			1	
6	99009-17400	CIRCLIP PRESILLA REDONDA			1	
7	90201-175F6	WASHER, PLATE ARANDELA PLANA			1	
8	36X-15641-00	GEAR, KICK (27T) ENGRANAJE PEDAL ARRANQUE(27T)			1	
9	90209-17226	WASHER ARANDELA DE SEPARACION			1	
10	93102-17263	OIL SEAL SELLO ACEITE			1	
11	90201-173F4	WASHER, PLATE ARANDELA PLANA			1	
12	15A-15651-01	GEAR, KICK IDLE (28T) PINON, LIBRE (28T)			1	
13	90214-17028	WASHER, CLAW ARANDELA DE POSICION			1	
14	99009-17400	CIRCLIP PRESILLA REDONDA		2		
15	36X-15620-01	KICK CRANK ASSY MANIVELA DE PEDAL COMPLETA			1	
16	36X-15621-02	.BOSS, KICK CRANK .COPA DE MANIVELA DE PEDAL			1	
17	90501-12081	.SPRING, COMPRESSION .RESORTE DE COMPRESION			1	
18	93507-32009	.BALL .ESFERA			1	
19	90152-06010	.SCREW, COUNTERSUNK .TORNILLO EMBUTIDO			1	
20	97027-08030	BOLT PERNO			1	
21	2HT-15512-00	GEAR, IDLER 1 (41T/10T) ENGRANAJE NEUTRO (41T/10T)			1	
22	90387-125Y0	COLLAR COLLAR			1	
23	5H0-15521-00	SHAFT 1 EJE 1			1	
24	5H0-15517-00	GEAR, IDLER 2 (56T) ENGRANAJE POSICION 2DA (56T)			1	
25	90201-25290	WASHER, PLATE ARANDELA PLANA			1	
26	4H7-15580-10	STARTER CLUTCH OUTER ASSY ENSAMBLE EXT.EMBRAGUE ARRANQUE			1	
27	90501-04596	.SPRING, COMPRESSION .RESORTE DE COMPRESION			3	

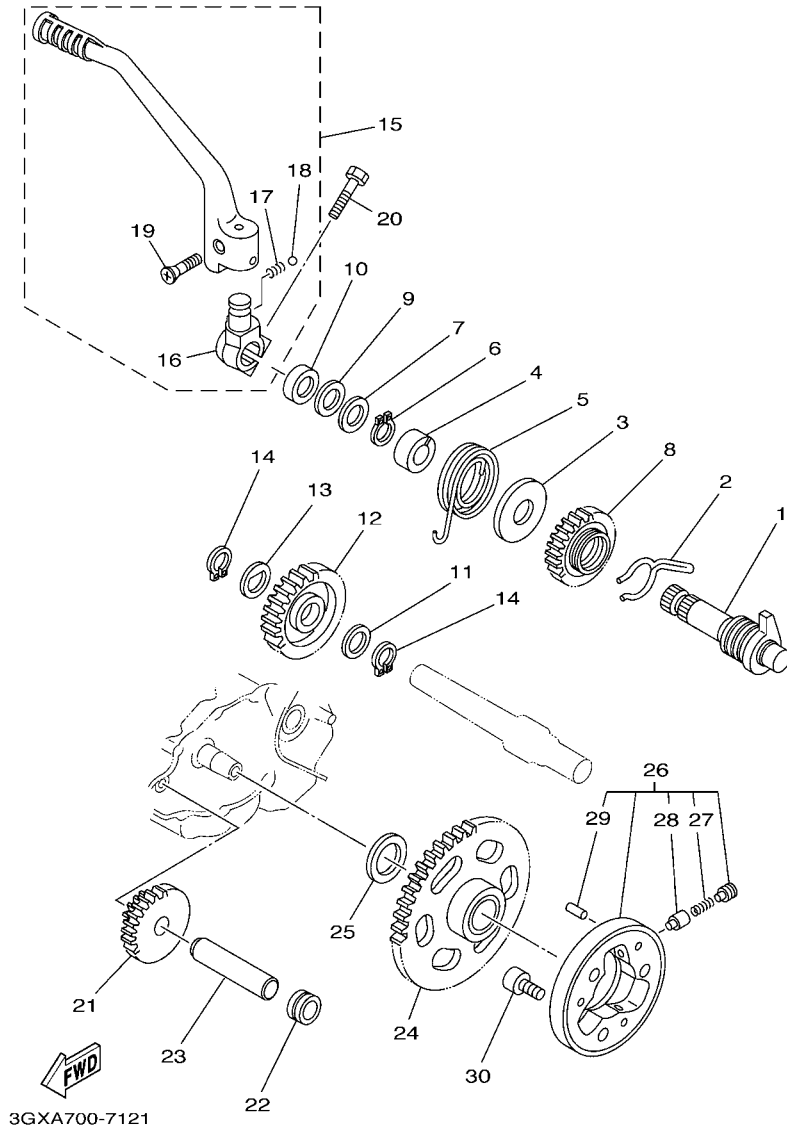
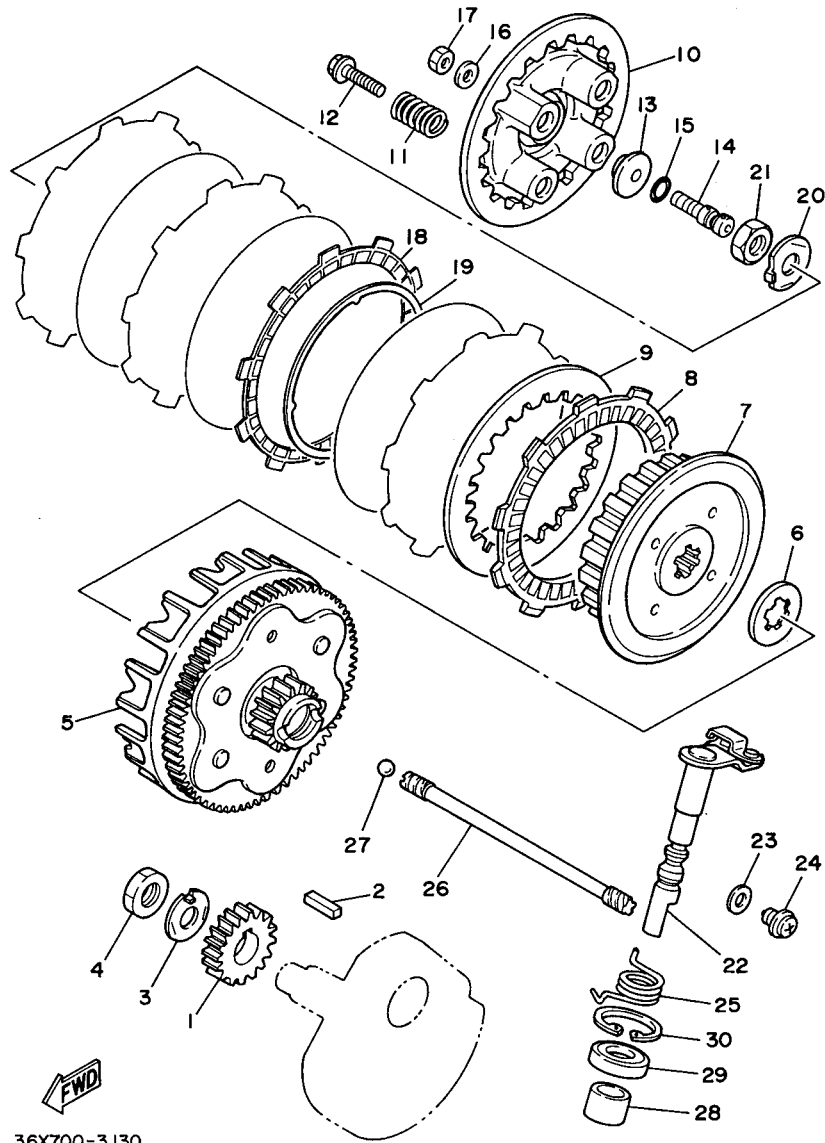

FIG. 14 STARTER 2

ARRANQUE 2

REF. NO.	PART NO. CODIGO Nº	DESCRIPTION DESCRIPCION	3GXL	3GXM	3GXN	REMARKS OBSERVACIONES
28	1J7-15583-01	.CAP. STARTER CLUTCH SPRING .TAPA RESORTE EMBRAG.ARRANQ.			3	
29	93615-12088	.PIN, DOWEL .PASADOR DE CLAVIJA			3	
30	91317-08020	BOLT PERNO			3	



36X700-3 130

FIG. 15 CLUTCH

EMBRAGUE

REF. NO.	PART NO. CODIGO N°	DESCRIPTION DESCRIPCION	3GXL	3GXM	3GXN	REMARKS OBSERVACIONES
1	36X-16111-00	GEAR, PRIMARY DRIVE (20T) ENGRANAJE TRACC.PRIMARIA(20T)	1	1	1	
2	90282-05043	KEY, STRAIGHT CHAVETA, RECTA	1	1	1	
3	90215-14205	WASHER, LOCK ARANDELA DE CIERRE	1	1	1	
4	90170-14284	NUT TUERCA	1	1	1	
5	36X-16150-00	PRIMARY DRIVEN GEAR COMP. CAMPANA DE EMBRAGUE	1	1	1	
6	5H0-16154-00	PLATE, THRUST 1 ARANDELA, DE EMPUJE 1	1	1	1	
7	36X-16371-00	BOSS, CLUTCH CUBO, DE EMBRAGUE	1	1	1	
8	537-16321-00	PLATE, FRICTION PLACA DE FRICCION	4	4	4	
9	137-16324-00	PLATE, CLUTCH 1 PLACA DE EMBRAGUE	4	4	4	
10	5H0-16351-00	PLATE, PRESSURE 1 PLATO DE PRESION	1	1	1	
11	90501-23700	SPRING, COMPRESSION RESORTE DE COMPRESION	4	4	4	
12	90159-05011	SCREW, WITH WASHER TORNILLO CON VALONA	4	4	4	
13	1W1-16358-01	PLATE, PUSH PLACA DE EMPUJE	1	1	1	
14	5H0-16356-01	ROD, PUSH 1 VARILLA DE EMPUJE 1	1	1	1	
15	93210-48364	O-RING ANILLO O	1	1	1	
16	92907-06200	WASHER ARANDELA	1	1	1	
17	95307-06600	NUT TUERCA	1	1	1	
18	36X-16321-00	PLATE, FRICTION PLACA DE FRICCION	1	1	1	
19	1KH-16383-00	SPRING, CLUTCH BOSS RESORTE DE COPA DE EMBRAGUE	1	1	1	
20	90215-14186	WASHER, LOCK ARANDELA DE CIERRE	1	1	1	
21	90170-14284	NUT TUERCA	1	1	1	
22	15A-16380-00	PUSH LEVER ASSY LEVA DE EMPUJE COMPLETA	1	1	1	
23	90430-08119	GASKET JUNTA	1	1	1	
24	90149-08067	SCREW TORNILLO DE REGLAJE	1	1	1	
25	90508-18537	SPRING, TORSION RESORTE DE TORSION	1	1	1	
26	5H0-16357-00	ROD, PUSH 2 VARILLA DE EMPUJE 2	1	1	1	
27	93505-16006	BALL BOLA	1	1	1	

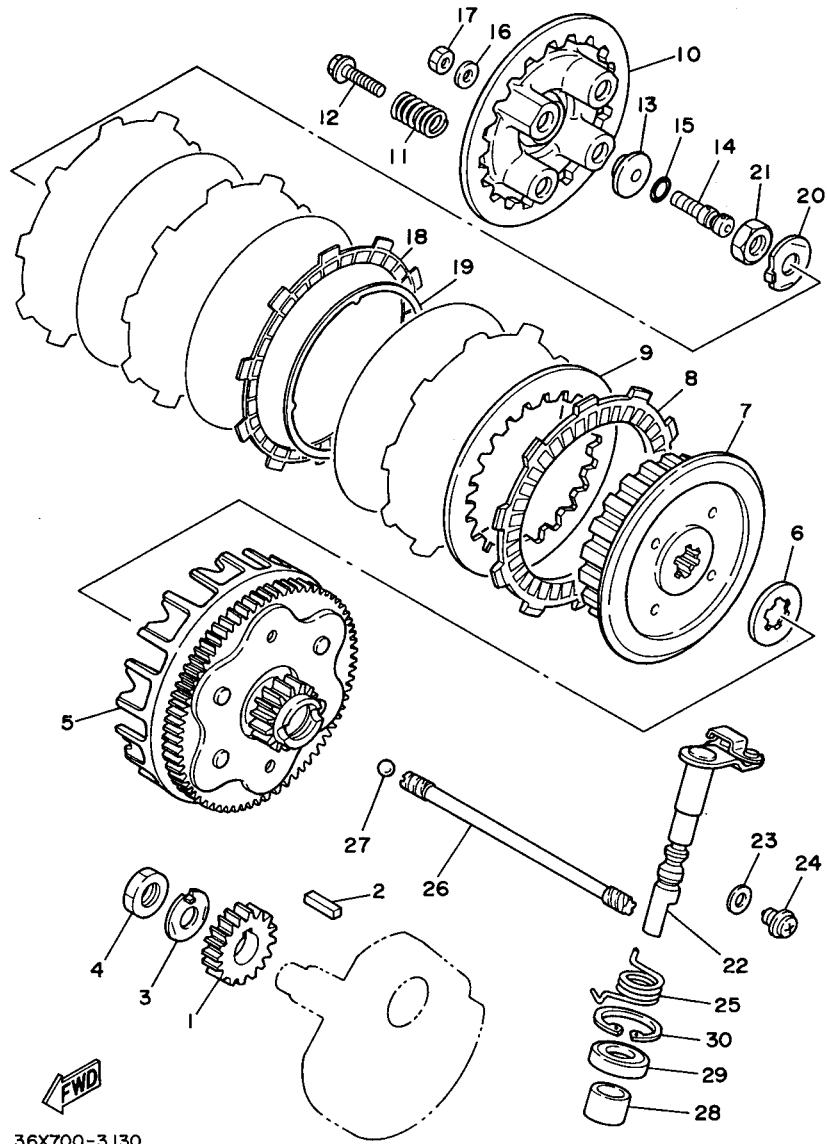
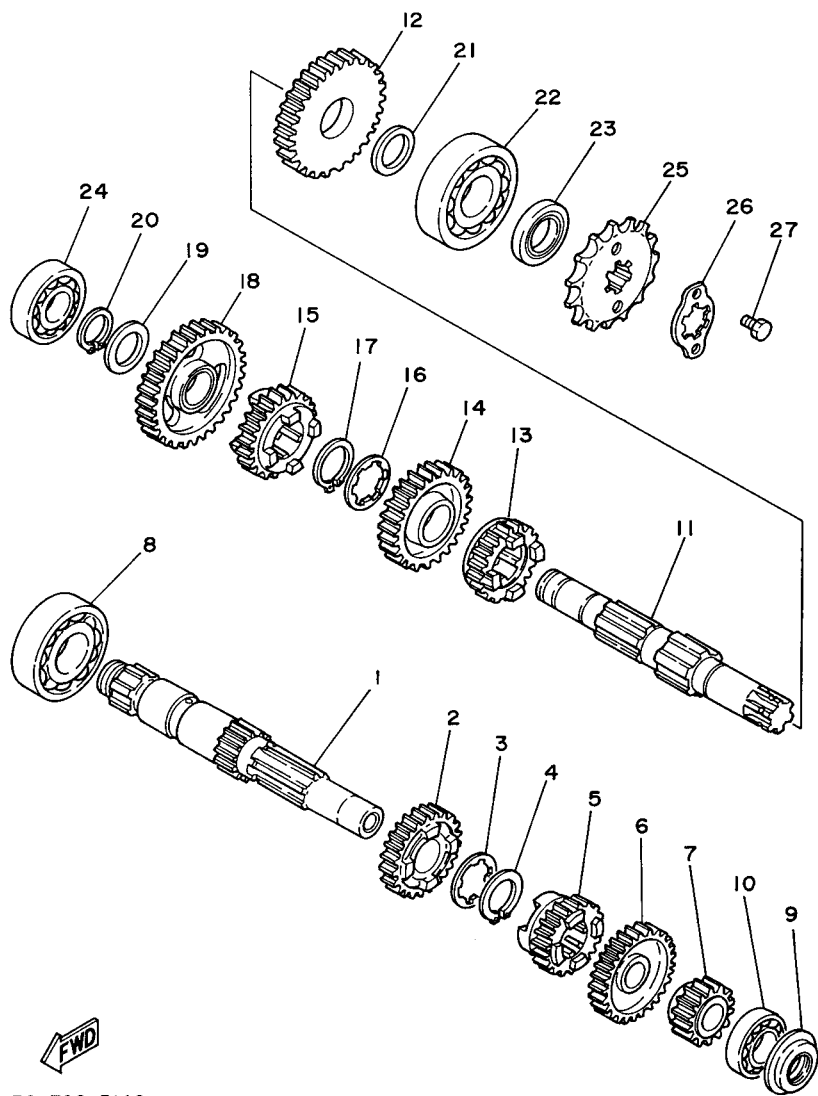

FIG. 15 CLUTCH

EMBRAGUE

REF. NO.	PART NO. CODIGO Nº	DESCRIPTION DESCRIPCION	3GXL	3GXM	3GXN	REMARKS OBSERVACIONES
28	90386-14103	BUSH BUJE	1	1	1	
29	93102-14209	OIL SEAL SELLO ACEITE	1	1	1	
30	93420-28055	CIRCLIP SEGURO	1	1	1	



36X700-3140

FIG. 16 TRANSMISSION

TRANSMISION

REF. NO.	PART NO. CODIGO Nº	DESCRIPTION DESCRIPCION	3GXL	3GXM	3GXN	REMARKS OBSERVACIONES
1	36X-17411-00	AXLE, MAIN (11T) EJE PRIMARIO (11T)	1	1	1	
2	36X-17141-01	GEAR, 4TH PINION (26T) ENGRANAJE PINON DE 4TA (26T)	1	1	1	
3	90209-16209	WASHER ARANDELA DE SEPARACION	1	1	1	
4	93410-20038	CIRCLIP SEGURO	1	1	1	
5	24W-17131-00	GEAR, 3RD PINION (21T) ENGRANAJE PINON DE 3RA (21T)	1	1	1	
6	36X-17151-00	GEAR, 5TH PINION (31T) ENGRANAJE PINON DE 5TA (31T)	1	1	1	
7	24W-17121-00	GEAR, 2ND PINION (15T) ENGRANAJE PINON DE 2DA (15T)	1	1	1	
8	93306-20401	BEARING COJINETE	1	1	1	
9	93101-15101	OIL SEAL SELLO ACEITE	1	1	1	
10	93306-20201	BEARING COJINETE	1	1	1	
11	15A-17402-01	DRIVE AXLE ASSY EJE DE TRACCION COMPLETO	1	1	1	
12	36X-17221-01	GEAR, 2ND WHEEL (31T) ENGRANAJE RUEDA DE 2DA (31T)	1	1	1	
13	36X-17251-00	GEAR, 5TH WHEEL (22T) ENGRANAJE RUEDA DE 5TA (22T)	1	1	1	
14	24W-17231-00	GEAR, 3RD WHEEL (30T) ENGRANAJE RUEDA DE 3RA (30T)	1	1	1	
15	36X-17241-01	GEAR, 4TH WHEEL (20T) ENGRANAJE DE RUEDA 4TA (20T)	1	1	1	
16	90209-18208	WASHER ARANDELA DE SEPARACION	1	1	1	
17	93410-22039	CIRCLIP SEGURO	1	1	1	
18	36X-17211-00	GEAR, 1ST WHEEL (35T) ENGRANAJE RUEDA DE 1 RA (35T)	1	1	1	
19	90201-17257	WASHER, PLATE ARANDELA PLANA	1	1	1	
20	99009-17400	CIRCLIP PRESILLA REDONDA	1	1	1	
21	90201-203E7	WASHER, PLATE ARANDELA PLANA	1	1	1	
22	93306-30424	BEARING COJINETE	1	1	1	
23	93102-20004	OIL SEAL SELLO ACEITE	1	1	1	
24	93306-20332	BEARING COJINETE	1	1	1	
25	93822-14043	SPROCKET,DRIVE (14T) RUEDA DENTAD (14T)	1	1	1	
26	5H0-17456-00	HOLDER, SPROCKET SOPORTE DE CORONA	1	1	1	
27	97027-06010	BOLT PERNO	2	2	2	

FIG. 17 SHIFT CAM & FORK

LEVA DE CAMBIO & HORQUILLA

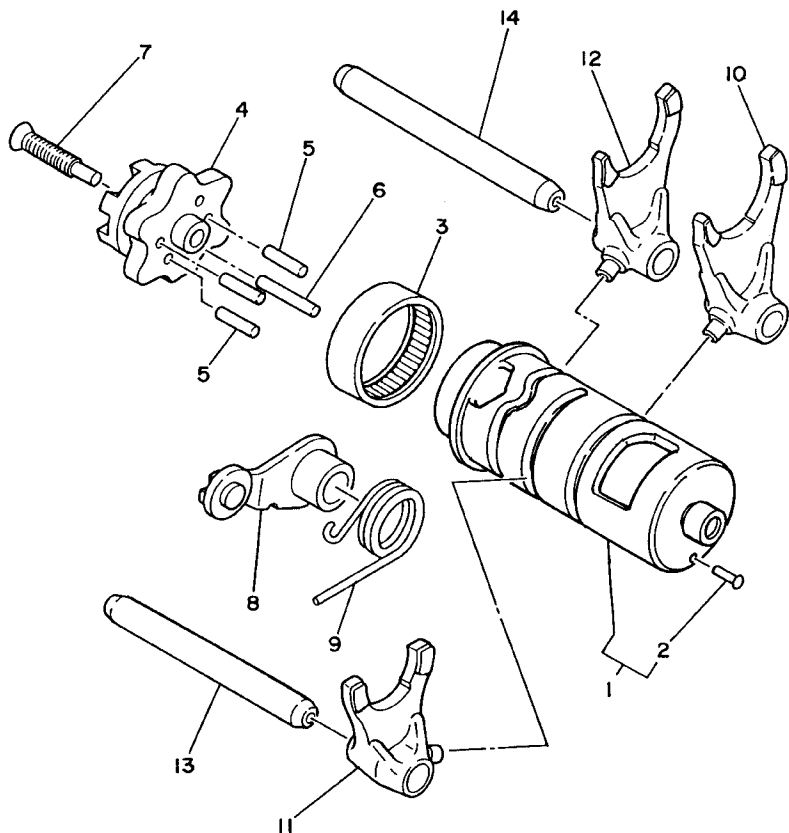

36X700-3151

REF. NO.	PART NO. CODIGO Nº	DESCRIPTION DESCRIPCION	3GXL	3GXM	3GXN	REMARKS OBSERVACIONES
1	36X-18540-00	SHIFT CAM ASSY LEVADEL CAMBIO COMPLETA	1	1	1	
2	136-18542-00	.POINT, NEUTRAL .PUNTO MVERTO	1	1	1	
3	93315-23607	BEARING COJINETE DE RODILLOS	1	1	1	
4	5H0-18185-01	SEGMENT SEGMENTO DE RETENCION	1	1	1	
5	93604-16092	PIN, DOWEL PASADOR DE CLAVIJA	4	4	4	
6	93604-20156	PIN, DOWEL PASADOR DE CLAVIJA	1	1	1	
7	90151-06013	SCREW, COUNTERSUNK TORNILLO EMBUTIDO	1	1	1	
8	4G0-18140-00	STOPPER LEVER ASSY PALANCA DE TOPE COMPLETA	1	1	1	
9	90508-26539	SPRING, TORSION RESORTE DE TORSION	1	1	1	
10	36X-18513-00	FORK, SHIFT 3 HORQUILLA DEL CAMBIO 3	1	1	1	
11	4JG-18511-00	FORK, SHIFT 1 HORQUILLA DEL CAMBIO 1	1	1	1	
12	4JG-18512-01	FORK, SHIFT 2 HORQUILLA DEL CAMBIO 2	1	1	1	
13	3GX-18531-00	BAR, SHIFT FORK GUIDE 1 BARRA GUIA HORQ. CAMBIO 1	1	1	1	
14	3GX-18535-00	BAR, SHIFT FORK GUIDE 2 BARRA GUIA HORQ.CAMBIO 2	1	1	1	

FIG. 18 SHIFT SHAFT

EJE DE CAMBIO & PEDAL

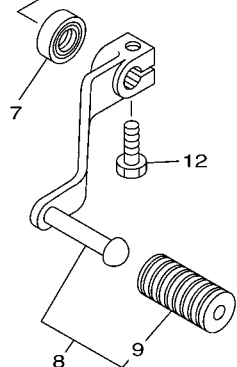
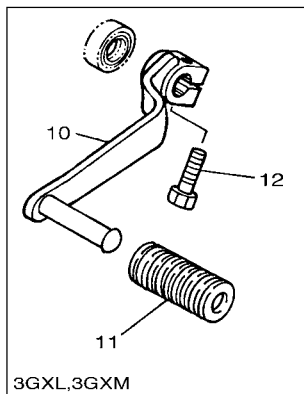
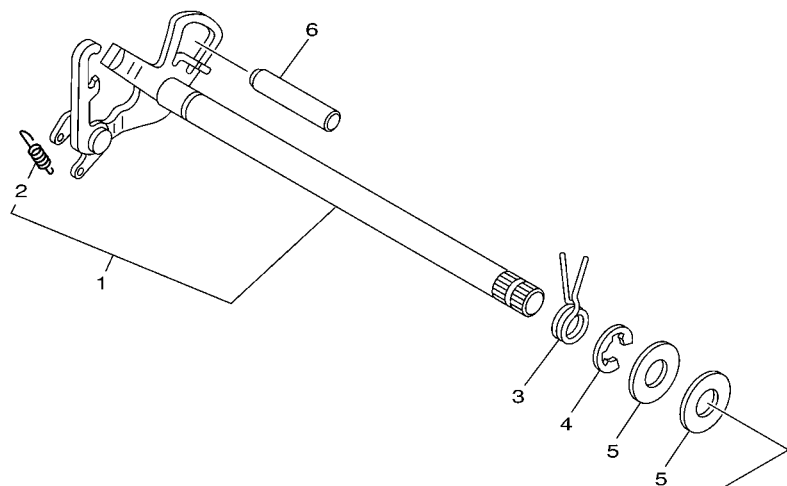

3GXL200-D180

REF. NO.	PART NO. CODIGO Nº	DESCRIPTION DESCRIPCION	3GXL	3GXM	3GXN	REMARKS OBSERVACIONES
1	5H0-18120-02	SHIFT LEVER ASSY PALANCA DE SELECTOR COMPLETO	1	1	1	
2	90506-08227	.SPRING, TENSION .RESORTE DE TENSION	1	1	1	
3	90508-29540	SPRING, TORSION RESORTE DE TORSION	1	1	1	
4	99001-10600	CIRCLIP PRESILLA REDONDA	1	1	1	
5	90201-12588	WASHER, PLATE ARANDELA PLANA	2	2	2	
6	93608-50158	PIN, DOWEL PASADOR DE CLAVIJA	1	1	1	
7	93102-12106	OIL SEAL (SD 12-22-5 HS) SELLO ACEITE (SD 12-22-5 HS)	1	1	1	
8	1RL-18110-00	SHIFT PEDAL ASSY PEDAL DE CAMBIO COMPLETO			1	
9	132-18113-01	.COVER, SHIFT PEDAL .FUNDA DEL PEDAL DEL CAMBIO			1	
10	36X-18111-00	PEDAL, SHIFT PEDAL DEL CAMBIO	1	1		
11	132-18113-01	COVER, SHIFT PEDAL FUNDA DEL PEDAL DEL CAMBIO	1	1		
12	97027-06020	BOLT PERNO	1	1	1	

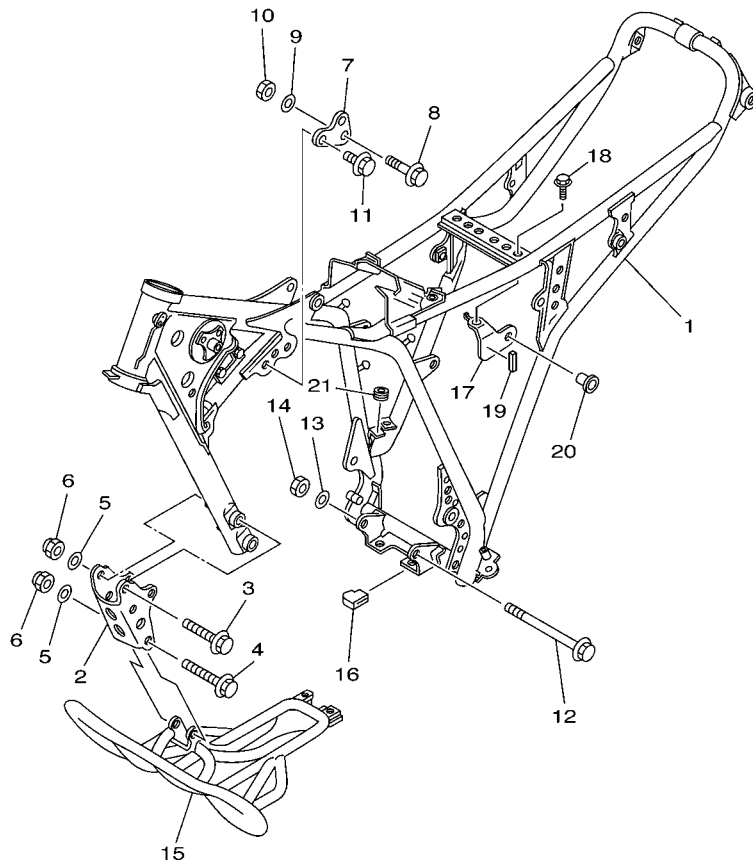

FWD
3GXL200-D190

FIG. 19 FRAME

CUADRO

REF. NO.	PART NO. CODIGO Nº	DESCRIPTION DESCRIPCION	3GXL	3GXM	3GXN	REMARKS OBSERVACIONES
1	3GX-21110-00-33	FRAME COMP. ARMAZON COMPLETO	1	1		YB YB
2	36X-21316-00	STAY, ENGINE 3 SOPORTE DE MOTOR 3	1	1		
3	95817-08065	BOLT, FLANGE TUERCA DE REBORDE	3	3		
4	95817-08070	BOLT, FLANGE TUERCA DE REBORDE	1	1		
5	90201-08366	WASHER, PLATE ARANDELA PLANA	4	4		
6	90185-08089	NUT, SELF-LOCKING TUERCA AUTOBLOCANTE	4	4		
7	36X-21315-00	STAY, ENGINE 2 SOPORTE DE MOTOR 2	1	1		
8	95817-08050	BOLT, FLANGE TUERCA DE REBORDE	1	1		
9	90201-08366	WASHER, PLATE ARANDELA PLANA	1	1		
10	90185-08089	NUT, SELF-LOCKING TUERCA AUTOBLOCANTE	1	1		
11	90105-08066	BOLT, FLANGE TORNILLO	2	2		
12	95827-08120	BOLT, FLANGE TUERCA DE REBORDE	1	1		
13	90201-08366	WASHER, PLATE ARANDELA PLANA	1	1		
14	90185-08089	NUT, SELF-LOCKING TUERCA AUTOBLOCANTE	1	1		
15	36X-21471-00	PROTECTOR, ENGINE PROTECTOR DE MOTOR	1	1		UR YB FOR YNS3 UR YB PARA YNS3
	36X-21471-20	PROTECTOR, ENGINE PROTECTOR DE MOTOR	1	1		UR SL FOR SBE UR SL PARA SBE
16	36X-21485-00	DAMPER, RUBBER 1 AMORTIGUADOR DE GOMA 1	2	2		
17	3GX-21287-10	BRACKET, REGULATOR SOPORTE DE REGULADOR	1	1		
18	95807-06012	BOLT, FLANGE TUERCA DE REBORDE	1	1		
19	5PS-28217-00	DAMPER 1 AMORTIGUADOR 1	1	1		
20	90179-06524	NUT TUERCA	1	1		
21	90480-14229	GROMMET TAPON	1	1		

FIG. 20 FRAME 2

CUADRO 2

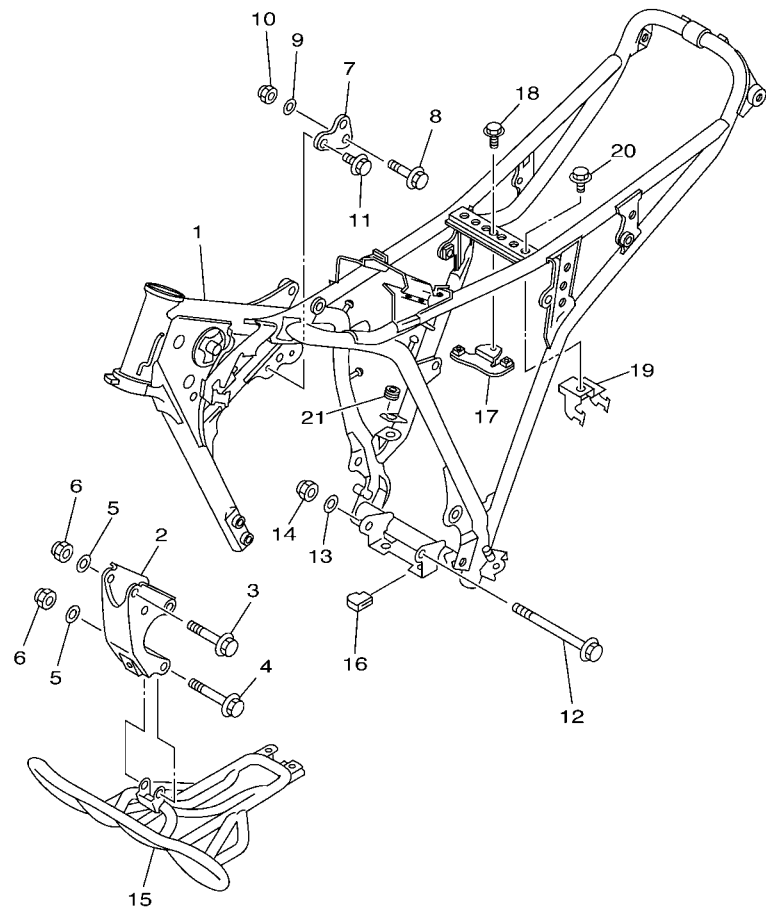

3GXF700-B170

REF. NO.	PART NO. CODIGO Nº	DESCRIPTION DESCRIPCION	3GXL	3GXM	3GXN	REMARKS OBSERVACIONES
1	3GX-21110-10-33	FRAME COMP. ARMAZON COMPLETO			1	YB
2	1RL-21316-00-33	STAY, ENGINE 3 SOPORTE DE MOTOR 3			1	YB
3	95817-08065	BOLT, FLANGE TUERCA DE REBORDE			3	YB
4	95817-08070	BOLT, FLANGE TUERCA DE REBORDE			1	
5	90201-08366	WASHER, PLATE ARANDELA PLANA			4	
6	90185-08089	NUT, SELF-LOCKING TUERCA AUTOBLOCANTE			4	
7	36X-21315-00	STAY, ENGINE 2 SOPORTE DE MOTOR 2			1	
8	95817-08050	BOLT, FLANGE TUERCA DE REBORDE			1	
9	90201-08366	WASHER, PLATE ARANDELA PLANA			1	
10	90185-08089	NUT, SELF-LOCKING TUERCA AUTOBLOCANTE			1	
11	90105-08066	BOLT, FLANGE TORNILLO			2	
12	95827-08120	BOLT, FLANGE TUERCA DE REBORDE			1	
13	90201-08366	WASHER, PLATE ARANDELA PLANA			1	
14	90185-08089	NUT, SELF-LOCKING TUERCA AUTOBLOCANTE			1	
15	36X-21471-10-35	PROTECTOR, ENGINE PROTECTOR DE MOTOR			1	SL
16	36X-21485-00	DAMPER, RUBBER 1 AMORTIGUADOR DE GOMA 1			2	SL
17	3GX-21287-00	BRACKET, REGULATOR SOPORTE DE REGULADOR			1	
18	95807-06008	BOLT, FLANGE TUERCA DE REBORDE			1	
19	3GX-2134E-00	BRACKET, RELAY SOPORTE DE RELE			1	
20	95807-06008	BOLT, FLANGE TUERCA DE REBORDE			1	
21	90480-14229	GROMMET TAPON			1	

FIG. 21 FENDER

GUARDABARRO

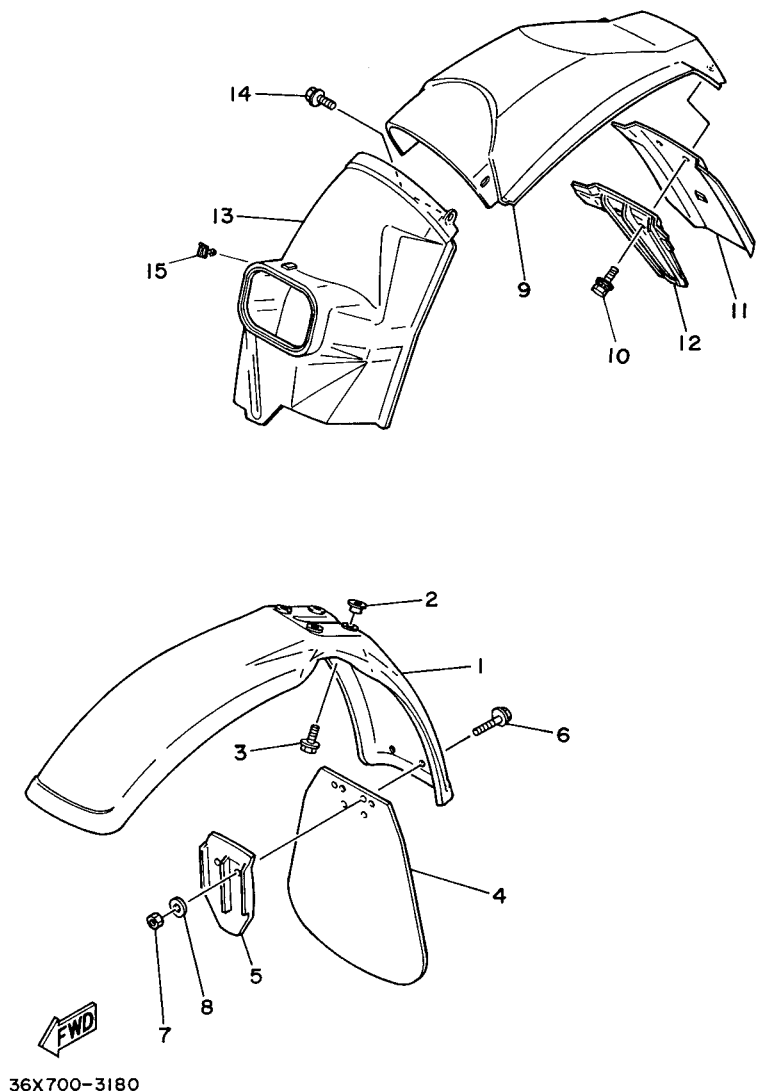

REF. NO.	PART NO. CODIGO Nº	DESCRIPTION DESCRIPCION	3GXL	3GXM	3GXN	REMARKS OBSERVACIONES
1	36X-21511-40	FENDER, FRONT GUARDABARRO DELANTERO	1	1		UR FOR YNS3 UR PARA YNS3
	36X-21511-60	FENDER, FRONT GUARDABARRO DELANTERO	1	1	1	UR FOR SBE UR PARA SBE
2	90387-062V8	COLLAR COLLAR	4	4	4	
3	90119-06063	BOLT, WITH WASHER TORNILLO CON ARANDELA	4	4	4	
4	36X-21521-00	FLAP, FRONT FENDER CHARNELA DE GUARDABARRO	1	1	1	
5	36X-21522-00	BAND, FLAP BANDA DE CHARNELA	1	1	1	
6	90159-06085	SCREW, WITH WASHER TORNILLO CON VALONA	2	2	2	
7	95307-06700	NUT TUERCA	2	2	2	
8	90201-06557	WASHER, PLATE ARANDELA PLANA	2	2	2	
9	36X-21611-20	FENDER, REAR GUARDABARRO TRASERO	1	1		UR FOR YNS3 UR PARA YNS3
	36X-21611-40	FENDER, REAR GUARDABARRO TRASERO	1	1	1	UR FOR SBE UR PARA SBE
10	90119-06097	BOLT, WITH WASHER TORNILLO CON ARANDELA	2	2	2	
11	36X-21621-00	FLAP CHARNELA	1	1	1	
12	36X-21622-00	BAND, FLAP BANDA DE CHARNELA	1	1	1	
13	36X-21629-01	GUARD, MUD GUARDABARRO INFERIOR	1	1	1	
14	90119-06063	BOLT, WITH WASHER TORNILLO CON ARANDELA	2	2	2	
15	90464-13249	CLAMP BRIDA	2	2	2	

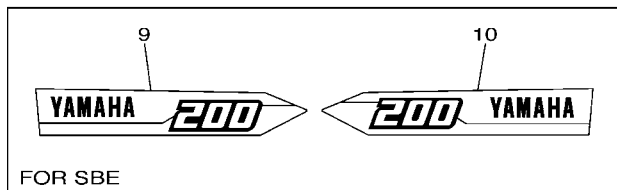
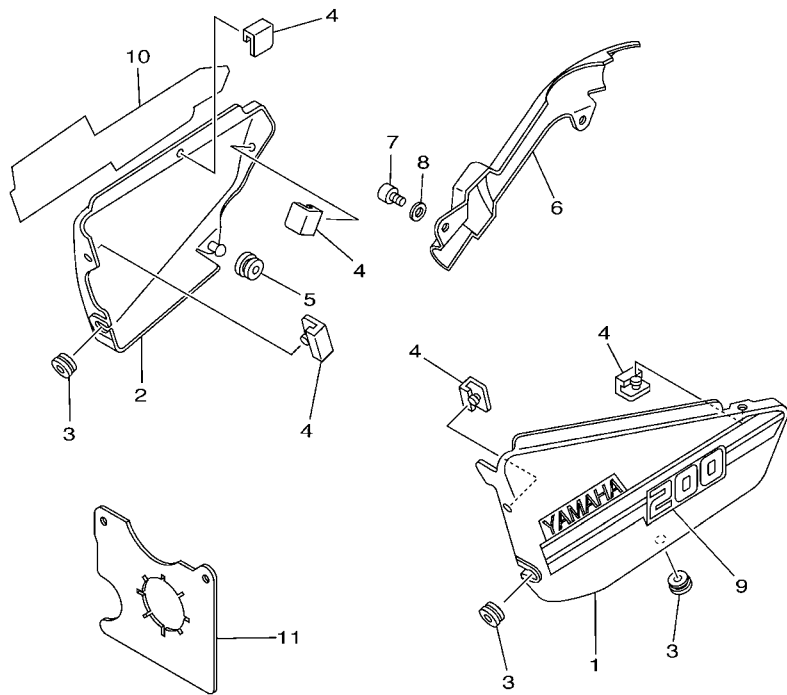

3GXG200-A190

FIG. 22 SIDE COVER

CUBIERTA LATERAL

REF. NO.	PART NO. CODIGO Nº	DESCRIPTION DESCRIPCION	3GXL	3GXM	3GXN	REMARKS OBSERVACIONES
1	36X-21711-20	COVER, SIDE 1 CUBIERTA LATERAL 1	1	1		UR FOR YNS3 UR PARA YNS3
	36X-21711-40	COVER, SIDE 1 CUBIERTA LATERAL 1	1	1	1	UR FOR SBE UR PARA SBE
2	36X-21721-20	COVER, SIDE 2 CUBIERTA LATERAL 2	1	1		UR FOR YNS3 UR PARA YNS3
	36X-21721-40	COVER, SIDE 2 CUBIERTA LATERAL 2	1	1	1	UR FOR SBE UR PARA SBE
3	90480-12320	GROMMET TAPON	3	3	3	
4	3M7-21746-00	DAMPER AMORTIGUADOR	5	5	5	
5	90480-01141	GROMMET TAPON	1	1		
	90480-01558	GROMMET TAPON			1	
6	36X-2172A-00	PANEL 1 PANEL 1	1	1	1	
7	98507-06012	SCREW, PAN HEAD TORNILLO DE CABEZA PLANA	2	2	2	
8	92907-06600	WASHER, PLATE ARANDELA	2	2	2	
9	3GX-2173E-10	GRAPHIC 1 GRAFICO 1	1	1		UR FOR YNS3 UR PARA YNS3
	3GX-2173E-30	GRAPHIC 1 GRAFICO 1	1	1	1	UR FOR SBE UR PARA SBE
10	3GX-2173F-10	GRAPHIC 2 GRAFICO 2	1	1		UR FOR YNS3 UR PARA YNS3
	3GX-2173F-30	GRAPHIC 2 GRAFICO 2	1	1	1	UR FOR SBE UR PARA SBE
11	36X-2177F-00	COVER CUBIERTA	1	1	1	

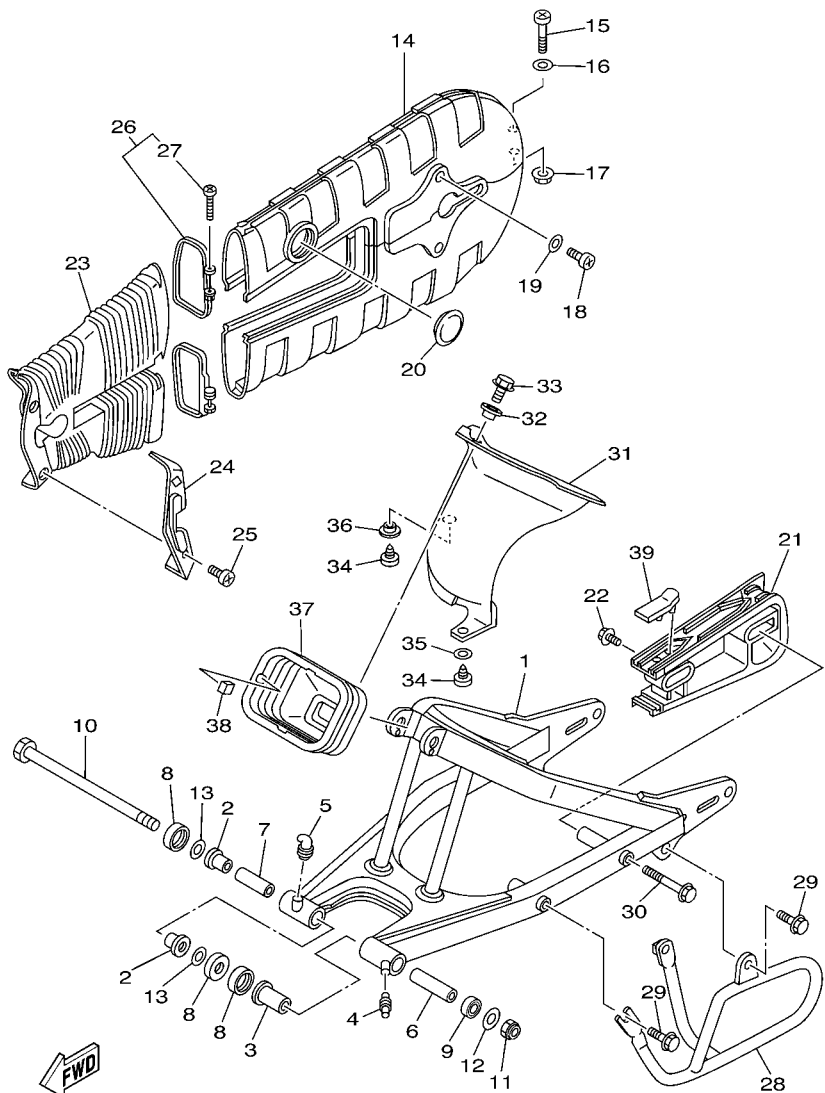

3GXX200-C200

FIG. 23 REAR ARM

BRAZO TRASERO

REF. NO.	PART NO. CODIGO Nº	DESCRIPTION DESCRIPCION	3GXL	3GXM	3GXN	REMARKS OBSERVACIONES
1	36X-22110-00-35	REAR ARM COMP. BRAZO TRASERO COMPLETO	1	1	1	SL SL
2	15A-22123-00	BUSH 1 BUJE 1	2	2	2	
3	90386-18028	BUSH BUJE	1	1	1	
4	93700-06004	NIPPLE, GREASE BOQUILLA DE ENGRASAR	1	1	1	
5	93700-06009	NIPPLE, GREASE BOQUILLA DE ENGRASAR	1	1	1	
6	36X-22126-00	COLLAR, DISTANCE COLLAR DISTANCIADOR	1	1	1	
7	36X-22126-10	COLLAR, DISTANCE COLLAR DISTANCIADOR	1	1	1	
8	401-22128-01	COVER, THRUST 1 TAPA DE EMPIJE 1	3	3	3	
9	93109-18020	OIL SEAL SELLO ACEITE	1	1	1	
10	3GX-22141-00	SHAFT, PIVOT EJE DEL BARCULANTE	1	1	1	
11	90185-12134	NUT, SELF-LOCKING TUERCA AUTOBLOCANTE	1	1	1	
12	90201-120A5	WASHER, PLATE ARANDELA PLANA	1	1	1	
13	401-22127-00	SHIM CUNA	1	1	1	UN UN
14	36X-22310-00-35	CHAIN CASE ASSY CAJA DE CADENA COMPLETA	1	1	1	SL SL
15	98507-06045	SCREW, PAN HEAD TORNILLO DE CABEZA PLANA	1	1	1	
16	92907-06600	WASHER, PLATE ARANDELA	1	1	1	
17	95607-06200	NUT, SELF U-FLANGE TUERCA DE AUTO-CIERRE	1	1	1	
18	98507-06016	SCREW, PAN HEAD TORNILLO DE CABEZA CON PLANA	2	2	2	
19	92907-06600	WASHER, PLATE ARANDELA	2	2	2	
20	148-22315-00	CAP TAPA	1	1	1	
21	36X-22358-00	SEAL 1 SELLO 1	1	1	1	
22	90119-06074	BOLT, WITH WASHER TORNILLO CON ARANDELA	1	1	1	
23	36X-22325-00	COVER, DUST CUBIERTA PARA POLVO	1	1	1	
24	36X-22324-00	STAY, DUST COVER SOPORTE DE CUBIERTA PARA POLVO	1	1	1	
25	98507-05008	SCREW, PAN HEAD TORNILLO DE CABEZA CON PLANA	2	2	2	
26	36X-22323-00	STAY, CHAIN CASE 3 SOPORTE DE CAJA DE CADENA 3	2	2	2	
27	98507-04030	SCREW, PAN HEAD TORNILLO DE CABEZA PLANA	1	1	1	

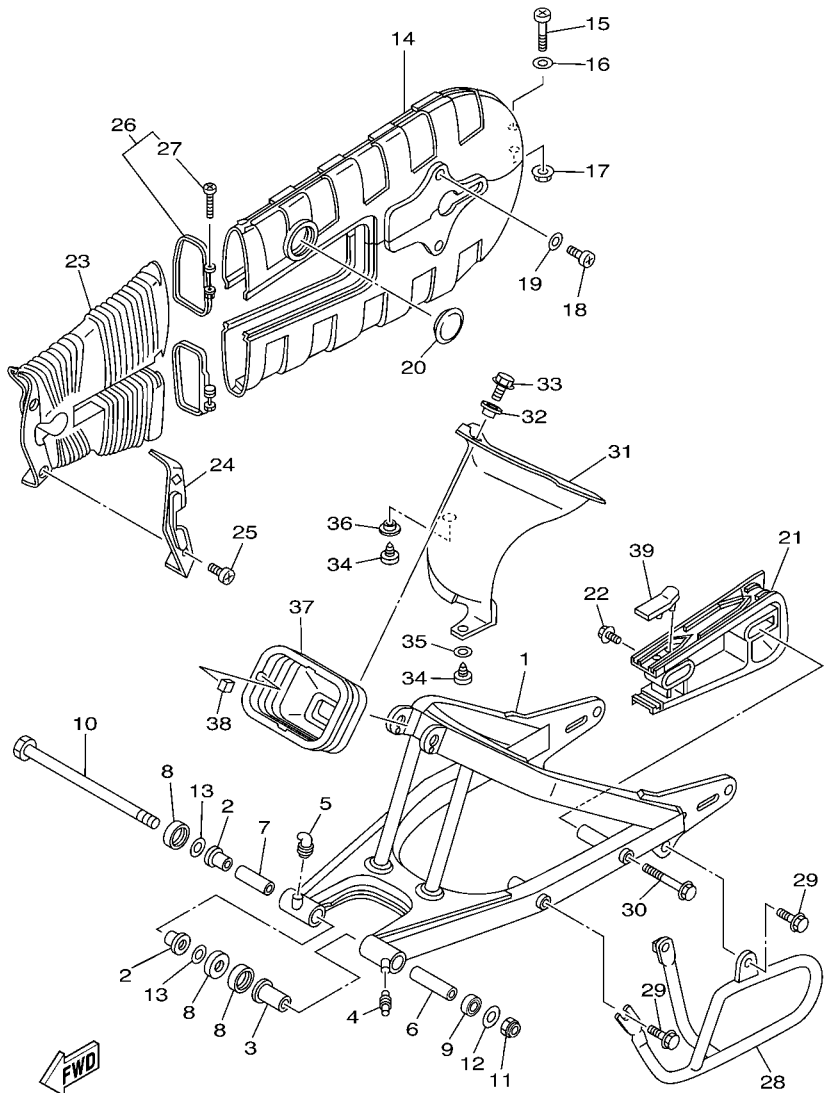

3GXX200-C200

FIG. 23 REAR ARM

BRAZO TRASERO

REF. NO.	PART NO. CODIGO Nº	DESCRIPTION DESCRIPCION	3GXL	3GXM	3GXN	REMARKS OBSERVACIONES
28	36X-22318-00	GUARD, CHAIN GUARDACADENA	1	1	1	
29	95807-08012	BOLT, FLANGE TUERCA DE REBORDE	2	2	2	
30	95827-08090	BOLT, FLANGE TUERCA DE REBORDE	1	1	1	
31	36X-22327-01	MUD GUARD 1 GUARDAFANGO 1	1	1	1	
32	90387-06681	COLLAR COLLAR	1	1	1	
33	95807-06016	BOLT, FLANGE TUERCA DE REBORDE	1	1	1	
34	97707-50512	SCREW, TAPPING TORNILLO ROSCA HEMBRA	2	2	2	
35	90201-05032	WASHER, PLATE ARANDELA PLANA	1	1	1	
36	90387-061M0	COLLAR COLLAR	1	1	1	
37	36X-22189-00	BOOT, RUBBER FUNDA DE GOMA	1	1	1	
38	90468-06134	CLIP PRESILLA	4	4	4	
39	36X-22151-00	SEAL, GUARD SELLO DE GUARDA	1	1	1	

FIG. 24 REAR SUSPENSION

SUSPENSION TRASERO

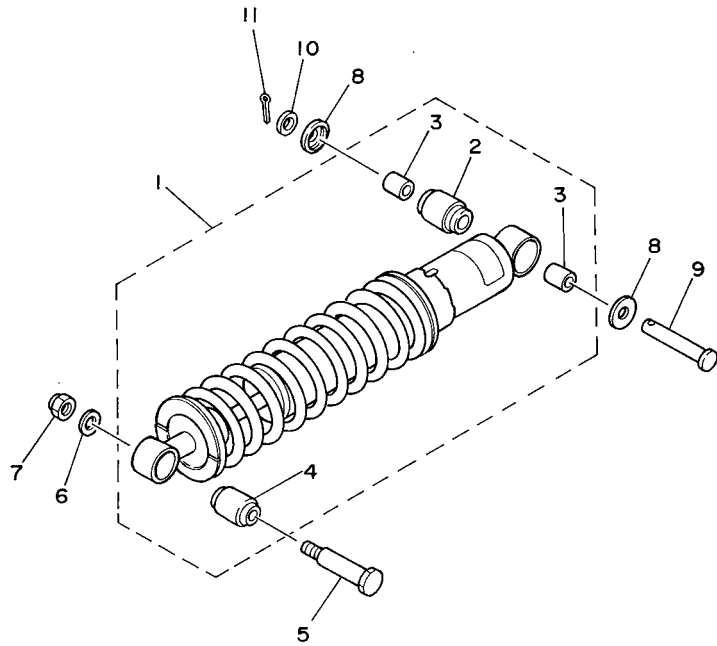

REF. NO.	PART NO. CODIGO Nº	DESCRIPTION DESCRIPCION	3GXL	3GXM	3GXN	REMARKS OBSERVACIONES
1	36X-22210-20	SHOCK ABSORBER ASSY, REAR AMORTIGUADOR TRASERO COMPLETO	1	1	1	
2	3R4-22226-00	.BUSH, SHOCK ABSORBER LOWER .BUJE DE AMORTIGUADOR INFERIO	1	1	1	
3	90380-12051	.BUSH, SOLID .CASQUILLO SOLIDO	2	2	2	
4	1YW-22216-00	.BUSH, REAR SHOCK ABSORBER .BUJE DEL AMORTIGUADOR TRASERO	1	1	1	
5	90109-10554	BOLT PERNO	1	1	1	
6	90201-10126	WASHER, PLATE ARANDELA PLANA	1	1	1	
7	95607-10100	NUT, U TUERCA AUTOBLOCANTE	1	1	1	
8	1W1-22128-00	COVER, THRUST 1 TAPA DE EMPIJE 1	2	2	2	
9	90240-12092	PIN, CLEVIS PASADOR CON HOYO	1	1	1	
10	92907-12600	WASHER, PLATE ARANDELA	1	1	1	
11	91401-25020	PIN, COTTER PASADOR DE CHAVETA	1	1	1	



36X700-3210

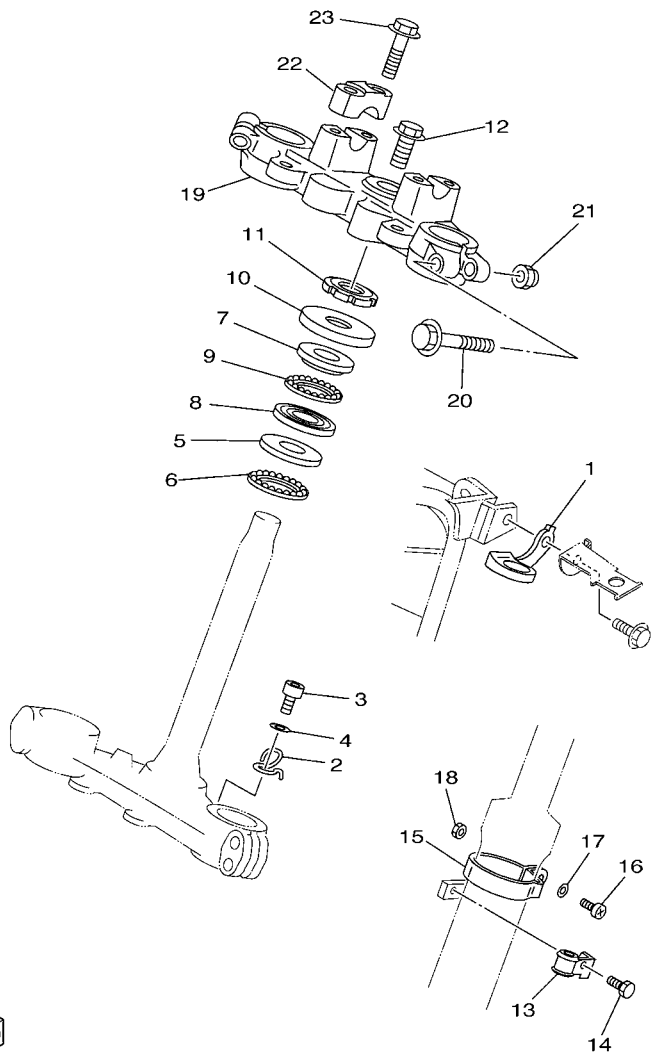

FIG. 25 STEERING

DIRECCION

REF. NO.	PART NO. CODIGO Nº	DESCRIPTION DESCRIPCION	3GXL	3GXM	3GXN	REMARKS OBSERVACIONES
1	36X-23389-00	GUIDE, CABLE GUIA DE CABLE	1	1	1	
2	36X-2331E-00	GUIDE, CABLE GUIA DE CABLE	1	1	1	
3	98507-06012	SCREW, PAN HEAD TORNILLO DE CABEZA PLANA	1	1	1	
4	92907-06600	WASHER, PLATE ARANDELA	1	1	1	
5	156-23412-00	RACE, BALL 2 PISTA DE BOLAS 2	1	1	1	
6	156-2341E-00	RETAINER, BALL BEARING RETEN DE COJINETE	1	1	1	
7	22F-23411-01	RACE, BALL 1 PISTA DE BOLAS 1	1	1	1	
8	22F-23412-01	RACE, BALL 2 PISTA DE BOLAS 2	1	1	1	
9	22F-2341E-00	RETAINER, BALL BEARING RETEN DE COJINETE	1	1	1	
10	36X-23416-00	COVER, BALL RACE 2 CUBIERTA DE BASE DE BOLA 2	1	1	1	
11	90179-25033	NUT TUERCA	1	1	1	
12	90105-14102	BOLT, FLANGE TORNILLO	1	1	1	
13	3Y1-23319-00	HOLDER, CABLE 2 SOSTEN DE CABLE 2	1	1	1	
14	95807-06012	BOLT, FLANGE TUERCA DE REBORDE	1	1	1	
15	3R9-23318-00	HOLDER, CABLE 1 SOSTEN DE CABLE 1	1	1	1	
16	98507-05016	SCREW, PAN HEAD TORNILLO DE CABEZA PLANA	1	1	1	
17	92907-05600	WASHER, PLATE ARANDELA	1	1	1	
18	95307-05600	NUT TUERCA	1	1	1	
19	36X-23435-00	CROWN, HANDLE PLATINA SUPERIOR	1	1	1	
20	95827-10060	BOLT, FLANGE TUERCA DE REBORDE	2	2	2	
21	90185-10091	NUT, SELF-LOCKING TUERCA AUTOBLOCANTE	2	2	2	
22	1E6-23441-10-98	HOLDER, HANDLE UPPER SOPORTE DE MANUBRIO	2	2	2	LGB LGB
23	95827-08035	BOLT, FLANGE TUERCA DE REBORDE	4	4	4	

FWD
3GXF700-B220

FIG. 26 FRONT FORK

HORQUILLA DELANTERA

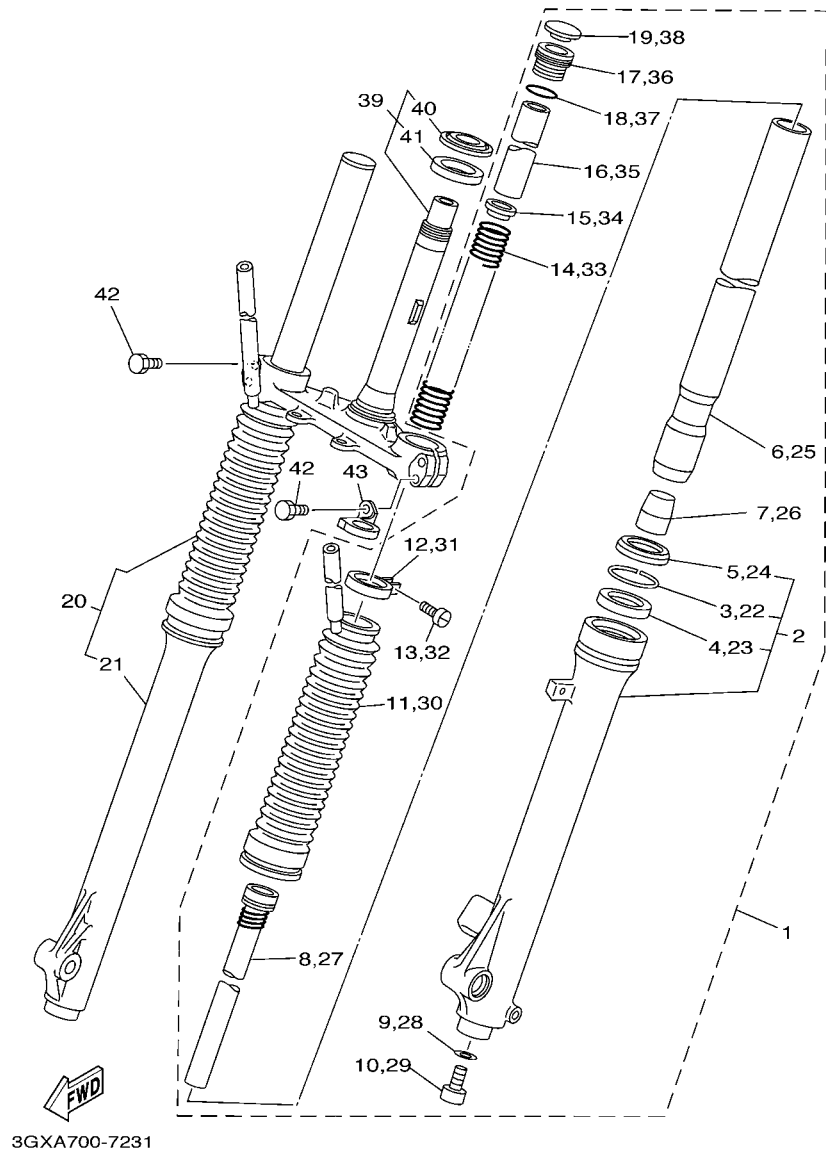

REF. NO.	PART NO. CODIGO Nº	DESCRIPTION DESCRIPCION	3GXL	3GXM	3GXN	REMARKS OBSERVACIONES
1	36X-23102-10	FRONT FORK ASSY (L.H) HORQUILLA DELANTERA COMPL.(MI)	1	1		
	36X-23102-20	FRONT FORK ASSY (L.H) HORQUILLA DELANTERA COMPL.(MI)			1	
2	36X-23107-00-35	.OUTER TUBE COMP. (R.H) .TUBO EXTERIOR COMPLETO (MD)	1	1	1	SL SL
3	4A1-23156-00	..CLIP, OIL SEAL ..PRESILLA DEL RETEN DE ACEITE	1	1	1	
4	1T3-23145-00	..OIL SEAL ..RETEN DE ACEITE	1	1	1	
5	3R2-23144-00	..SEAL, DUST ..GUARDAPOLVO	1	1	1	
6	36X-23110-00	.INNER TUBE COMP.1 .TUBO INTERIOR COMPLETO 1	1	1	1	
7	1W1-23173-L0	.SPINDLE, TAPER .VASTAGO AHUSADO	1	1	1	
8	36X-23170-00	.CYLINDER COMP., FRONT FORK .CILINDRO COMPL DE HORQ DELAN	1	1	1	
9	509-23158-L0	.GASKET .EMPAQUE	1	1	1	
10	278-23181-50	.BOLT, HEXAGON SOCKET HEAD .TORNILLO CABEZAHEXAGONAL	1	1	1	
11	36X-23191-10	.BOOT .FUNDA	1	1	1	
12	36X-23192-00	.BAND .BANDA	1	1	1	
13	4V2-23194-L0	.SCREW, BOOT BAND .TORNILLO DE BANDA DE FUNDA	1	1	1	
14	36X-23141-00	.SPRING, FRONT FORK .RESORTE HORQUILLA DELANT.	1	1	1	
15	3DM-23149-10	.WASHER, SPRING UPPER .ARANDELA DE RESORTE SUPERIOR	1	1	1	
16	36X-23118-00	.SPACER .SEPARADOR	1	1		
	2JL-23118-00	.SPACER .SEPARADOR			1	
17	1U6-23111-M1	.BOLT, CAP .TAPON	1	1	1	
18	240-23114-00	.GASKET .EMPAQUE	1	1	1	
19	1U6-23168-M0	.CAP, FRONT FORK .TAPA DE HORQUILLA DELANTERA	1	1	1	
20	36X-23103-10	FRONT FORK ASSY (R.H) HORQUILLA DELANTERA COMPL.(MD)	1	1		
	36X-23103-20	FRONT FORK ASSY (R.H) HORQUILLA DELANTERA COMPL.(MD)			1	
21	36X-23106-00-35	.OUTER TUBE COMP. (L.H) .TUBO EXTERIOR COMPLETO (MI)	1	1	1	SL SL
22	4A1-23156-00	..CLIP, OIL SEAL ..PRESILLA DEL RETEN DE ACEITE	1	1	1	
23	1T3-23145-00	..OIL SEAL ..RETEN DE ACEITE	1	1	1	
24	3R2-23144-00	..SEAL, DUST ..GUARDAPOLVO	1	1	1	

FIG. 26 FRONT FORK

HORQUILLA DELANTERA

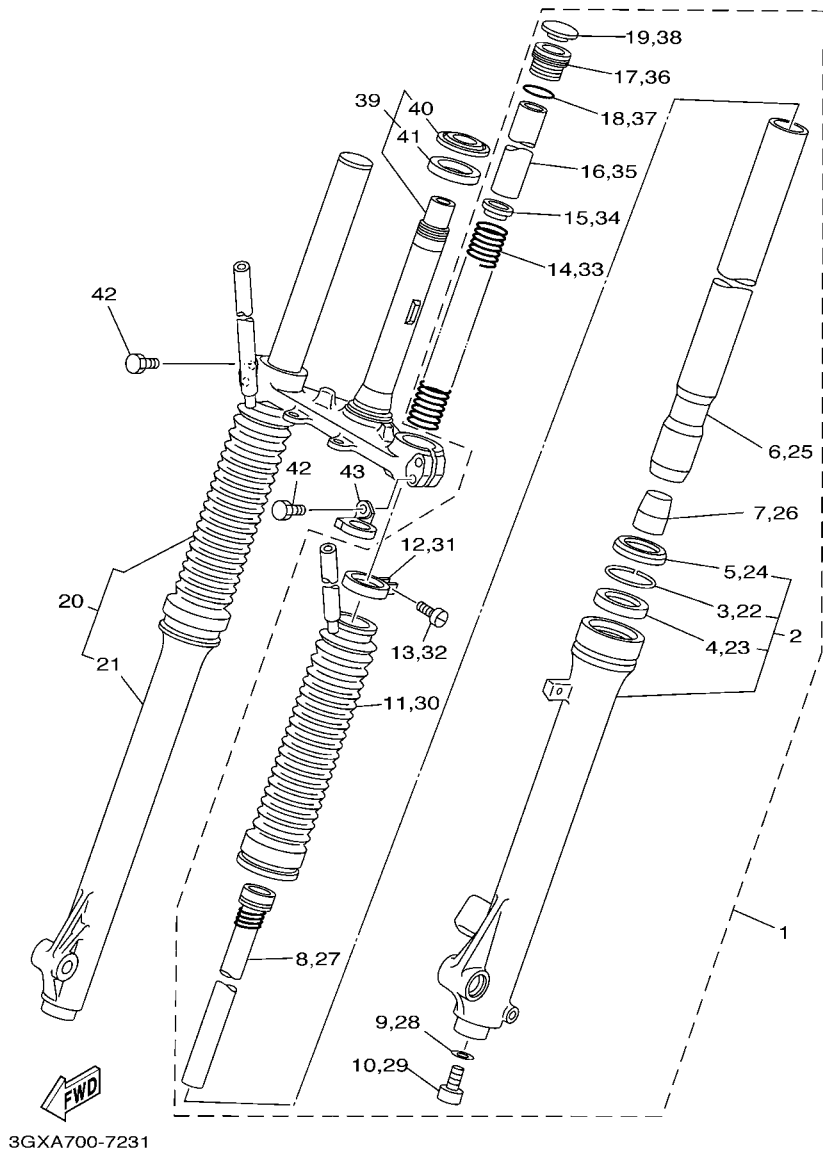

REF. NO.	PART NO. CODIGO Nº	DESCRIPTION DESCRIPCION	3GXL	3GXM	3GXN	REMARKS OBSERVACIONES
25	36X-23110-00	.INNER TUBE COMP.1 .TUBO INTERIOR COMPLETO 1	1	1	1	
26	1W1-23173-L0	.SPINDLE, TAPER .VASTAGO AHUSADO	1	1	1	
27	36X-23170-00	.CYLINDER COMP., FRONT FORK .CILINDRO COMPL. DE HORQ DELAN	1	1	1	
28	509-23158-L0	.GASKET .EMPAQUE	1	1	1	
29	278-23181-50	.BOLT, HEXAGON SOCKET HEAD .TORNILLO CABEZAHEXAGONAL	1	1	1	
30	36X-23191-10	.BOOT .FUNDA	1	1	1	
31	36X-23192-00	.BAND .BANDA	1	1	1	
32	4V2-23194-L0	.SCREW, BOOT BAND .TORNILLO DE BANDA DE FUNDA	1	1	1	
33	36X-23141-00	.SPRING, FRONT FORK .RESORTE HORQUILLA DELANT.	1	1	1	
34	3DM-23149-10	.WASHER, SPRING UPPER .ARANDELA DE RESORTE SUPERIOR	1	1	1	
35	36X-23118-00	.SPACER .SEPARADOR	1	1		
	2JL-23118-00	.SPACER .SEPARADOR			1	
36	1U6-23111-M1	.BOLT, CAP .TAPON	1	1	1	
37	240-23114-00	.GASKET .EMPAQUE	1	1	1	
38	1U6-23168-M0	.CAP, FRONT FORK .TAPA DE HORQUILLA DELANTERA	1	1	1	
39	36X-23340-01	UNDER BRACKET COMP. PLATINA INFERIOR COMPLETA	1	1	1	
40	156-23411-00	.RACE, BALL 1 .PISTA DE BOLAS 1	1	1	1	
41	164-23462-00	.SEAL, STEERING .RETEN DE DIRECCION	1	1	1	
42	3YF-23181-00	BOLT, HEXAGON SOCKET HEAD TORNILLO CABEZAHEXAGONAL	4	4	4	
43	3R4-23389-00	GUIDE, CABLE GUIA DE CABLE	1	1	1	

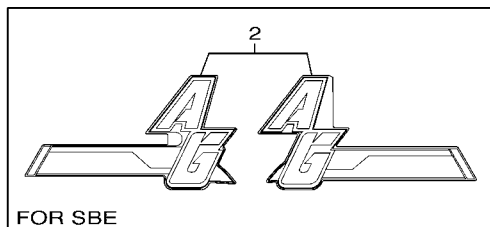
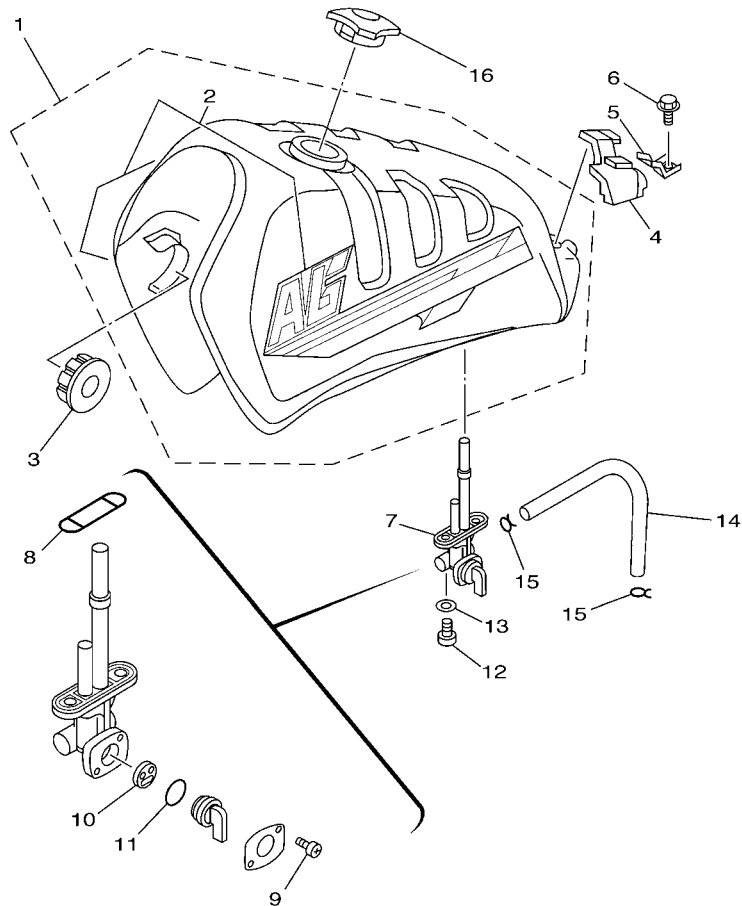

3GXG200-A240

FIG. 27 FUEL TANK

DEPOSITO DE COMBUSTIBLE

REF. NO.	PART NO. CODIGO Nº	DESCRIPTION DESCRIPCION	3GXL	3GXM	3GXN	REMARKS OBSERVACIONES
1	36X-24110-10-02	FUEL TANK COMP. DEPOSITO DE COMBUSTIBLE COMP.	1	1		UR YNS3 UR YNS3
	36X-Y2410-10-02	FUEL TANK COMP. DEPOSITO DE COMBUSTIBLE COMP.	1	1		UR SBE UR SBE
2	3GX-24240-10	.GRAPHIC SET .JUEGO DE CALCOMANIAS	1	1		UR FOR YNS3 UR PARA YNS3
	3GX-24240-40	.GRAPHIC SET .JUEGO DE CALCOMANIAS	1	1		UR FOR SBE UR PARA SBE
3	4H7-24181-00	DAMPER, LOCATING 1 AMORTIGUADOR DE MONTAJE 1	2	2		
4	36X-24182-00	DAMPER, LOCATING 2 AMORTIGUADOR DE MONTAJE 2	1	1		
5	36X-24186-00	WASHER, SPECIAL ARANDELA ESPECIAL	2	2		
6	95807-06016	BOLT, FLANGE TUERCA DE REBORDE	2	2		
7	23F-24500-11	FUEL COCK ASSY 1 GRIFO DE COMBUSTIBLE 1	1	1		
8	4X8-24512-00	O-RING EMPAQUE	1	1		
9	98507-03008	SCREW, PAN HEAD TORNILLO DE CABEZA PLANA	2	2		
10	3AC-24523-00	VALVE PACKING VALVULA	1	1		
11	3AJ-24534-01	SEAL, COCK SELLO DE GRIFO	1	1		
12	90149-06011	SCREW TORNILLO DE REGLAJE	2	2		
13	90202-05193	WASHER, PLATE ARANDELA DE PLANA	2	2		
14	90445-10638	HOSE (L145) TUBO (L145)	1	1		
15	90467-09006	CLIP PRESILLA	2	2		
16	36X-24610-00	CAP ASSY TAPA COMPLETA	1	1		

FIG. 28 FUEL TANK 2

DEPOSITO DE COMBUSTIBLE 2

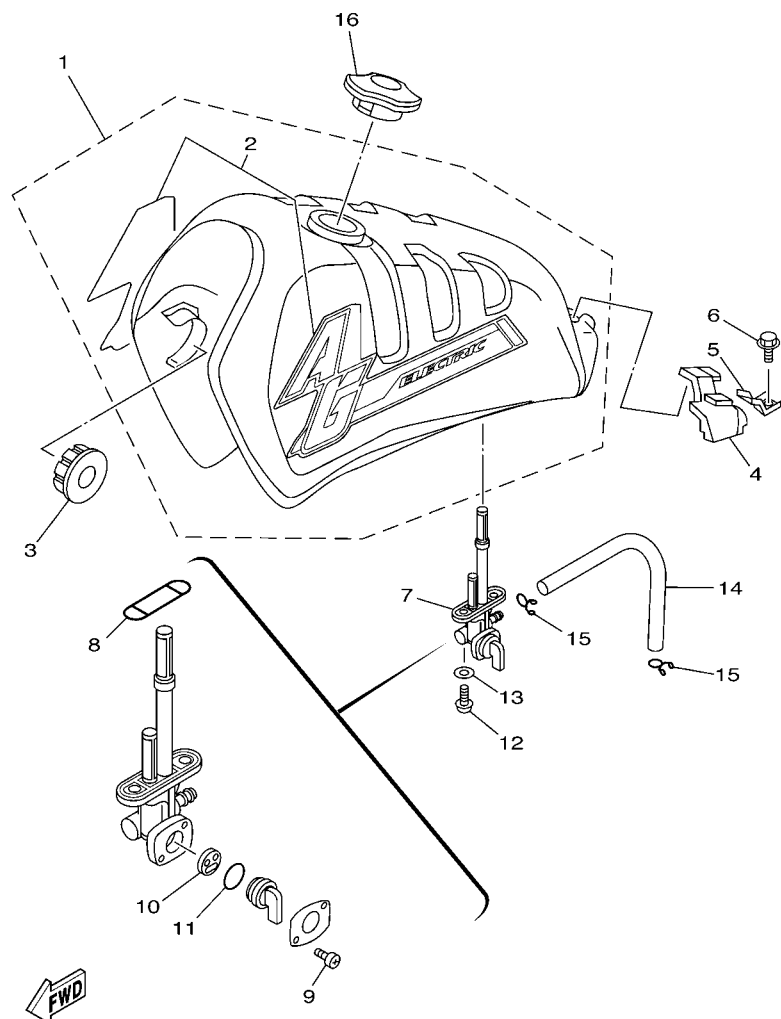

3GXK200-C240

REF. NO.	PART NO. CODIGO Nº	DESCRIPTION DESCRIPCION	3GXL	3GXM	3GXN	REMARKS OBSERVACIONES
1	36X-Y2410-10-01	FUEL TANK COMP. DEPOSITO DE COMBUSTIBLE COMP.			1	SBE SBE
2	3GX-24240-30	.GRAPHIC SET .JUEGO DE CALCOMANIAS			1	
3	4H7-24181-00	DAMPER, LOCATING 1 AMORTIGUADOR DE MONTAJE 1			2	
4	36X-24182-00	DAMPER, LOCATING 2 AMORTIGUADOR DE MONTAJE 2			1	
5	36X-24186-00	WASHER, SPECIAL ARANDELA ESPECIAL			2	
6	95807-06016	BOLT, FLANGE TUERCA DE REBORDE			2	
7	23F-24500-11	FUEL COCK ASSY 1 GRIFO DE COMBUSTIBLE 1			1	
8	4X8-24512-00	.O-RING .EMPAQUE			1	
9	98507-03008	.SCREW, PAN HEAD .TORNILLO DE CABEZA PLANA			2	
10	3AC-24523-00	.VALVE PACKING .VALVULA			1	
11	3AJ-24534-01	.SEAL, COCK .SELLO DE GRIFO			1	
12	90149-06011	SCREW TORNILLO DE REGLAJE			2	
13	90202-05193	WASHER, PLATE ARANDELA DE PLANA			2	
14	90445-10638	HOSE (L145) TUBO (L145)			1	
15	90467-09006	CLIP PRESILLA			2	
16	36X-24610-00	CAP ASSY TAPA COMPLETA			1	

FIG. 29 SEAT

ASIENTO

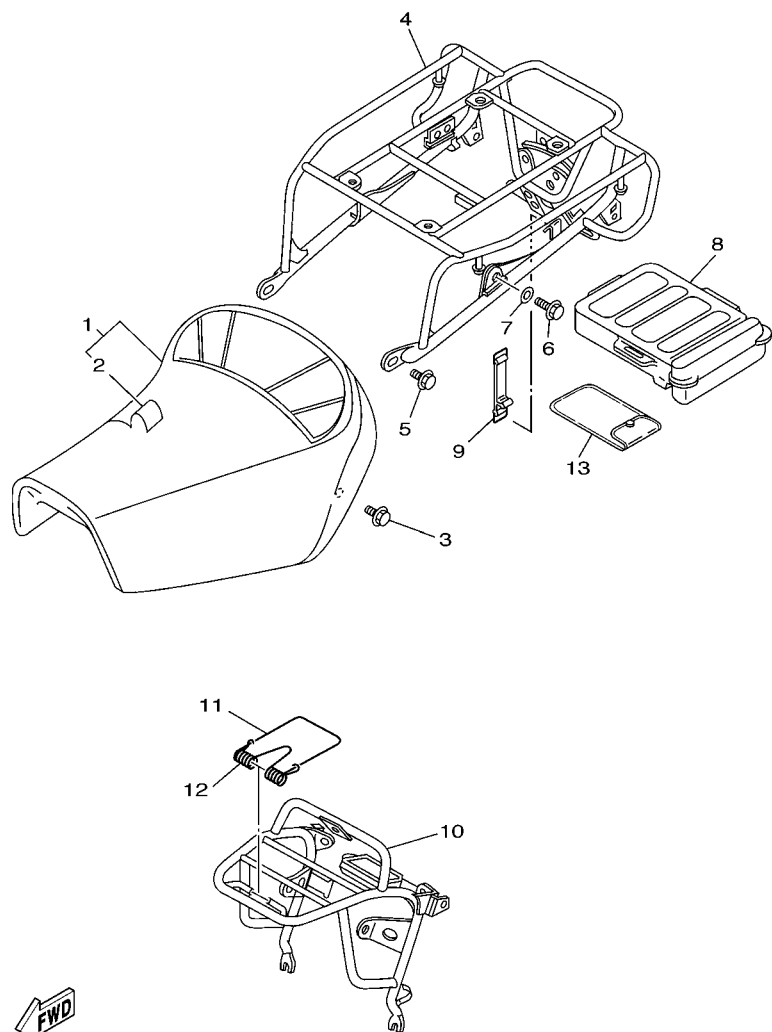

3GXA700-7251

REF. NO.	PART NO. CODIGO Nº	DESCRIPTION DESCRIPCION	3GXL	3GXM	3GXN	REMARKS OBSERVACIONES
1	3GX-24710-31	SINGLE SEAT ASSY ASIENTO SIMPLE COMPLETO	1	1	1	
2	3GX-24711-31	.COVER, SINGLE SEAT .CUBIERTA DE ASIENTO SIMPLE	1	1	1	
3	90119-06063	BOLT, WITH WASHER TORNILLO CON ARANDELA	2	2	2	
4	36X-24810-00-98	CARRIER ASSY PORTADOR COMPLETO	1	1		UR LGB FOR YNS3 UR LGB PARA YNS3
	36X-24810-00-35	CARRIER ASSY PORTADOR COMPLETO	1	1		UR SL FOR SBE UR SL PARA SBE
	36X-24810-10-35	CARRIER ASSY PORTADOR COMPLETO			1	SL SL
5	95817-08012	BOLT, FLANGE TUERCA DE REBORDE	2	2	2	
6	90105-08141	BOLT, FLANGE TORNILLO	1	1	1	
7	90201-08326	WASHER, PLATE ARANDELA PLANA	1	1	1	
8	36X-21107-00	TOOL BOX COMP. CAJA DE HERRAMIENTAS COMPL.	1	1	1	
9	36X-2811G-00	BAND BANDA	1	1	1	
10	36X-24860-00-98	FRONT CARRIER ASSY PORTADOR DELANTERO COMPLETO	1	1		UR LGB FOR YNS3 UR LGB PARA YNS3
	36X-24860-00-35	FRONT CARRIER ASSY PORTADOR DELANTERO COMPLETO	1	1		UR SL FOR SBE UR SL PARA SBE
	36X-24860-10-35	FRONT CARRIER ASSY PORTADOR DELANTERO COMPLETO			1	SL SL
11	36X-24862-00	CLAMP, CARRIER GRAMPA DE PORTADOR	1	1	1	
12	36X-24861-00	SPRING, FRONT CARRIER RESORTE DE PORTADOR DELANTERO	1	1	1	
13	36X-28100-00	TOOL KIT JUEGO DE HERRAMIENTAS	1	1	1	

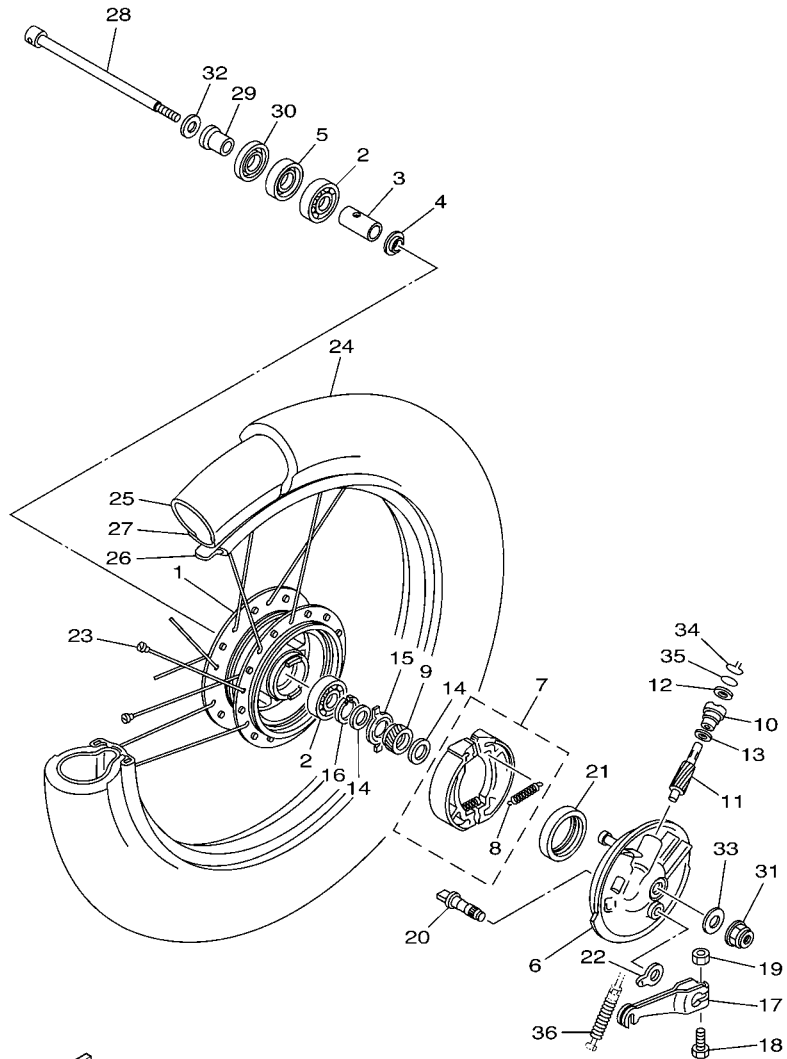

3GXL200-D300

FIG. 30 FRONT WHEEL

RUEDA DELANTERA

REF. NO.	PART NO. CODIGO Nº	DESCRIPTION DESCRIPCION	3GXL	3GXM	3GXN	REMARKS OBSERVACIONES
1	248-25111-00-35	HUB, FRONT MASA DELANTERA	1	1		SL
2	93306-30103	BEARING COJINETE	2	2		SL
3	90560-12138	SPACER SEPARADOR	1	1		
4	109-25315-00	FLANGE, SPACER SEPARADOR	1	1		
5	93102-18008	OIL SEAL SELLO ACEITE	1	1		
6	23F-25121-00-35	PLATE, BRAKE SHOE PLACA DE ZAPATA DE FRENO	1	1		SL
7	4BE-W253E-00	BRAKE SHOE KIT JUEGO DE ZAPATA DE FRENO	1	1		SL
8	90506-15260	.SPRING, TENSION .RESORTE DE TENSION	2	2		
9	36X-25135-00	GEAR, DRIVE ENGRANAJE DE TRACCION	1	1		
10	109-25136-00	BUSH BUJE	1	1		
11	36X-25138-00	GEAR, METER ENGRANAJE DE MEDIDOR	1	1		
12	93104-07003	OIL SEAL SELLO ACEITE	1	1		
13	90201-07076	WASHER, PLATE ARANDELA PLANA	1	1		
14	90201-20269	WASHER, PLATE ARANDELA PLANA	2	2		
15	183-25149-00	CLUTCH, METER EMBRAGUE DEL CUENTAKMS	1	1		
16	99009-20400	CIRCLIP PRESILLA REDONDA	1	1		
17	558-25155-00	LEVER, CAMSHAFT 1 PALANCA DE ARBOL DE LEVAS	1	1		
18	90101-06278	BOLT TORNILLO	1	1		
19	95307-06600	NUT TUERCA	1	1		
20	3Y6-25351-00	CAMSHAFT ARBOL DE LEVAS	1	1		
21	93102-47297	OIL SEAL SELLO ACEITE	1	1		
22	23F-2533A-00	PLATE, INDICATOR PLACA INDICADOR	1	1		
23	3V6-25104-00	SPOKE SET, FRONT JUEGO DE RAYOS DELANTERO	1	1		
24	94130-195E9	TIRE (3.00-19) NEUMATICO (3.00-19)	1	1		INOUE
25	94227-19292	TUBE (2.75-19 TR4) TUBO (2.75-19 TR4)	1	1		INOUE
26	94327-19111	BAND, RIM (1.40-19) BANDA DE ARO (1.40-19)	1	1		INOUE
27	94416-19002	RIM (1.60-19) ARO (1.60-19)	1	1		INOUE

FIG. 31 FRONT WHEEL 2

RUEDA DELANTERA 2

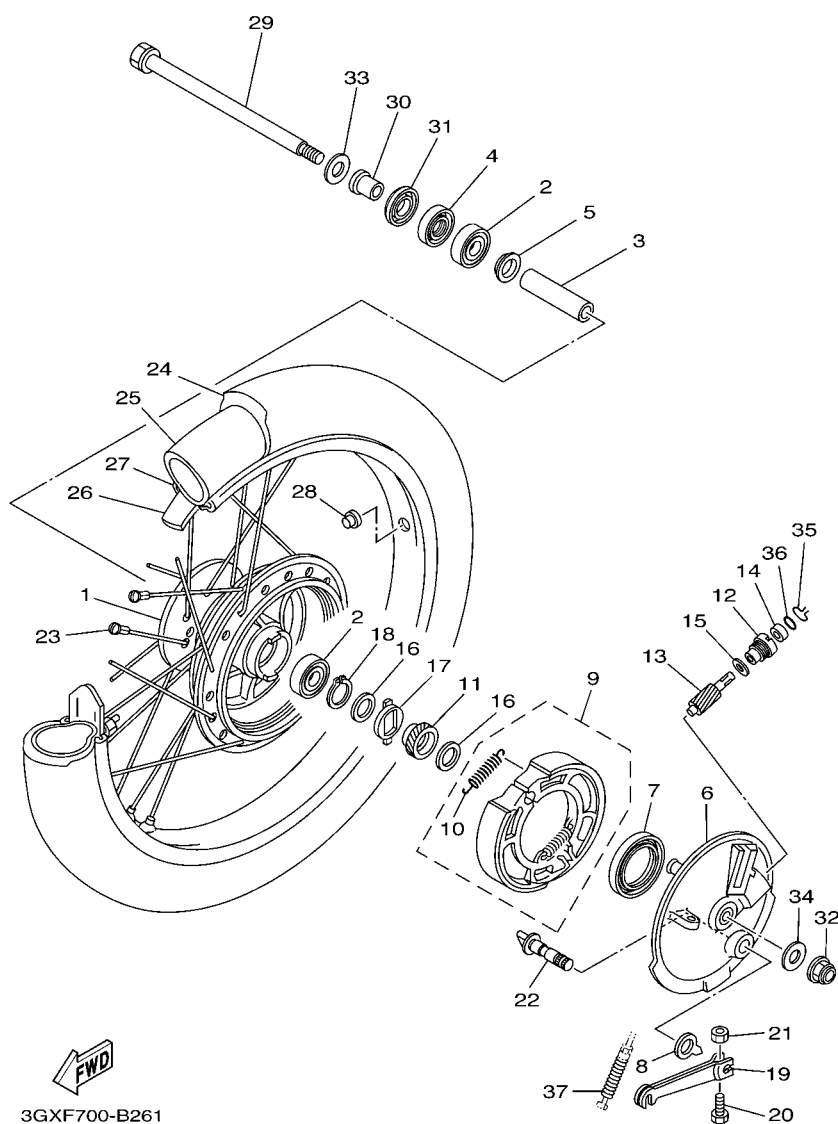

REF. NO.	PART NO. CODIGO Nº	DESCRIPTION DESCRIPCION	3GXL	3GXM	3GXN	REMARKS OBSERVACIONES
1	2A6-25111-00-35	HUB, FRONT MASA DELANTERA			1	SL
2	93306-30101	BEARING COJINETE			2	SL
3	90560-12138	SPACER SEPARADOR			1	
4	93102-18008	OIL SEAL SELLO ACEITE			1	
5	109-25315-00	FLANGE, SPACER SEPARADOR			1	
6	3TL-25121-00-35	PLATE, BRAKE SHOE PLACA DE ZAPATA DE FRENO			1	SL
7	93105-47007	OIL SEAL SELLO ACEITE			1	
8	3Y6-2533A-01	PLATE, INDICATOR PLACA INDICADOR			1	
9	3KG-W253E-00	BRAKE SHOE KIT JUEGO DE ZAPATA DE FRENO			1	
10	90506-15260	.SPRING, TENSION .RESORTE DE TENSION			2	
11	5J0-25135-00	GEAR, DRIVE (31T) ENGRANAJE DE TRACCION (31T)			1	
12	109-25136-00	BUSH BUJE			1	
13	5J0-25138-00	GEAR, METER ENGRANAJE DE MEDIDOR			1	
14	93104-07003	OIL SEAL SELLO ACEITE			1	
15	90201-07076	WASHER, PLATE ARANDELA PLANA			1	
16	90201-20269	WASHER, PLATE ARANDELA PLANA			2	
17	183-25149-00	CLUTCH, METER EMBRAGUE DEL CUENTAKMS			1	
18	99009-20400	CIRCLIP PRESILLA REDONDA			1	
19	2N4-25155-00	LEVER, CAMSHAFT 1 PALANCA DE ARBOL DE LEVAS			1	
20	90101-06278	BOLT TORNILLO			1	
21	95307-06600	NUT TUERCA			1	
22	248-25351-10	CAMSHAFT ARBOL DE LEVAS			1	
23	2A6-25104-01	SPOKE SET, FRONT JUEGO DE RAYOS DELANTERO			1	
24	94108-2111T	TIRE (80/100-21 51M VE32) NEUMATICO (80/100-21 51M VE32)			1	INOUE
25	94227-21293	TUBE (80/100-21 TR4) TUBO (80/100-21 TR4)			1	INOUE
26	94330-21088	BAND, RIM (22-21) BANDA DE ARO (22-21)			1	INOUE
27	94416-21006	RIM (1.60-21) ARO (1.60-21)			1	INOUE

FIG. 32 REAR WHEEL

RUEDA TRASERA

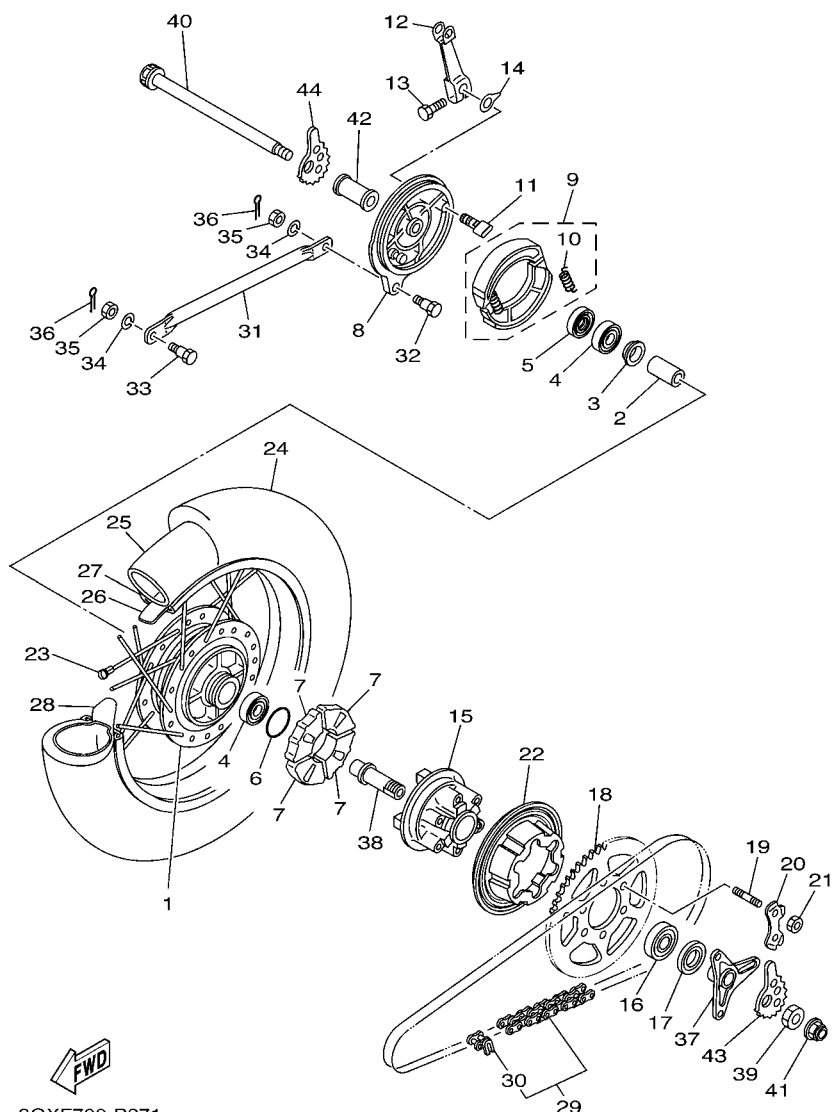

3GXF700-B271

REF. NO.	PART NO. CODIGO Nº	DESCRIPTION DESCRIPCION	3GXL	3GXM	3GXN	REMARKS OBSERVACIONES
1	391-25311-00-35	HUB, REAR MASA TRASERA	1	1	1	SL
2	90560-15136	SPACER SEPARADOR	1	1	1	
3	183-25315-00	FLANGE, SPACER SEPARADOR	1	1	1	
4	93306-20212	BEARING COJINETE	2	2	2	
5	93104-22018	OIL SEAL SELLO ACEITE	1	1	1	
6	93210-42101	O-RING ANILLO O	1	1	1	
7	36X-25364-00	DAMPER AMORTIGUADOR	4	4	4	
8	248-25321-00-35	PLATE, BRAKE SHOE PLACA DE ZAPATA DE FRENO	1	1	1	SL
9	3FA-W253A-00	BRAKE SHOE KIT JUEGO DE ZAPATA DE FRENO	1	1	1	
10	90506-15260	SPRING, TENSION RESORTE DE TENSION	2	2	2	
11	248-25351-10	CAMSHAFT ARBOL DE LEVAS	1	1	1	
12	4V8-25355-00	LEVER, CAMSHAFT PALANCA DE ARBOL DE LEVAS	1	1	1	
13	90101-06291	BOLT TORNILLO	1	1	1	
14	5T9-2533A-00	PLATE, INDICATOR PLACA INDICADOR	1	1	1	
15	31G-25366-00	CLUTCH, HUB EMBRAGUE DE MASA	1	1	1	
16	93306-00416	BEARING COJINETE	1	1	1	
17	93106-26005	OIL SEAL SELLO ACEITE	1	1	1	
18	15A-25454-11	SPROCKET, DRIVEN (54T) CORONA (54T)	1	1	1	
19	90116-08425	BOLT, STUD ESPARRAGO	6	6	6	
20	90215-08160	WASHER, LOCK ARANDELA DE CIERRE	3	3	3	
21	90170-08258	NUT TUERCA	6	6	6	
22	36X-25327-00	COVER, PLATE CUBIERTA DE PLACA	1	1	1	
23	3V6-25304-00	SPOKE SET, REAR JUEGO DE RAYOS TRASEROS	1	1	1	
24	94141-185E8	TIRE (4.10-18 4PR) NEUMATICO (4.10-18 4PR)	1	1	1	INOUE
25	94232-18113	TUBE (3.50-18 TR4) TUBO (3.50-18 TR4)	1	1	1	INOUE
26	94325-18081	BAND, RIM (2.50-18) BANDA DE ARO (2.50-18)	1	1	1	INOUE
27	94418-18008	RIM (1.85-18) ARO (1.85-18)	1	1	1	INOUE

FIG. 32 REAR WHEEL

RUEDA TRASERA

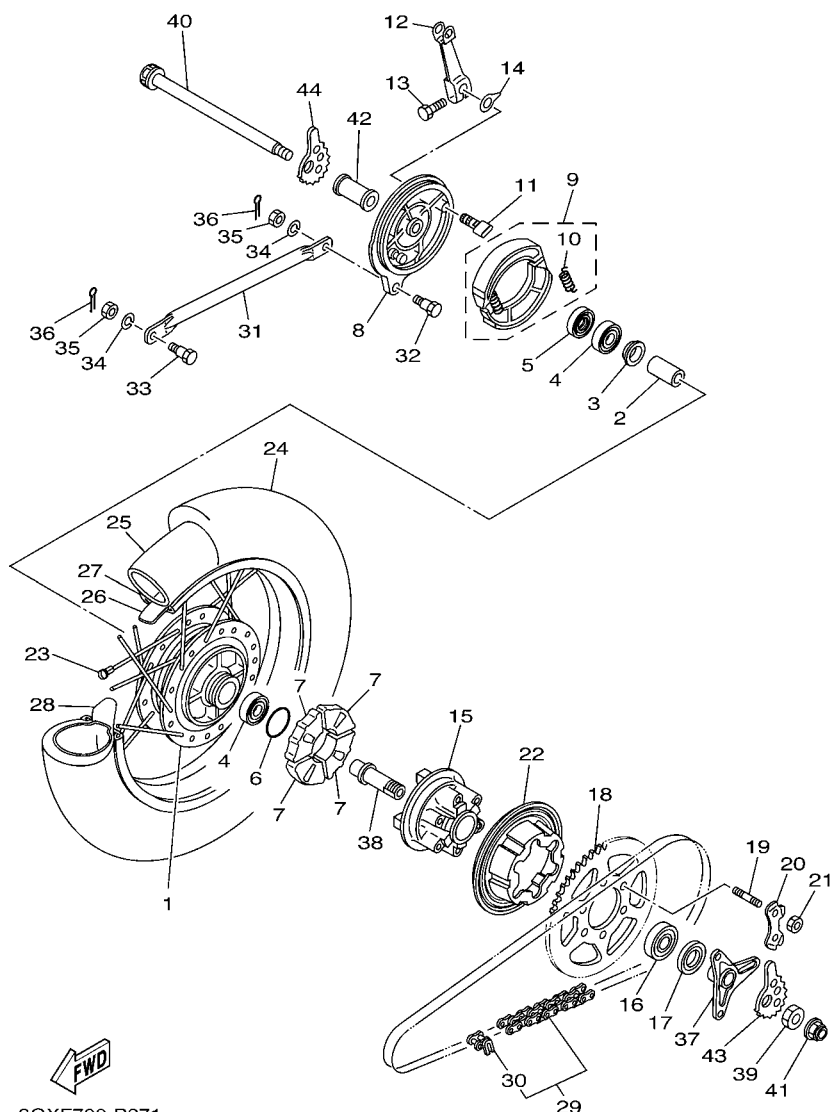

3GXF700-B271

REF. NO.	PART NO. CODIGO Nº	DESCRIPTION DESCRIPCION	3GXL	3GXM	3GXN	REMARKS OBSERVACIONES
28	1T2-25394-00	SPACER, BEAD ESPACIDOR DE BANCADA	1	1	1	
29	94580-88122	CHAIN (DID 428HG-122L) CADENA (DID 428HG-122L)	1	1	1	
30	94680-88001	.JOINT, CHAIN (DID 428HG) .CONECTOR DE CADENA(DID 428HG)	1	1	1	
31	3V6-25371-00	BAR, TENSION BARRA TENSORA	1	1	1	
32	90109-08063	BOLT PERNO	1	1	1	
33	90109-08368	BOLT PERNO	1	1	1	
34	92907-08100	WASHER, SPRING ARANDELA	2	2	2	
35	95307-08700	NUT TUERCA	2	2	2	
36	91401-20012	PIN, COTTER PASADOR DE CHAVETA	2	2	2	
37	36X-25386-00	COLLAR, SPROCKET AXLE COLLAR EJE DE RUEDA DENTADA	1	1	1	
38	36X-25387-00	AXLE, SPROCKET EJE DE CORONA	1	1	1	
39	90170-20224	NUT TUERCA	1	1	1	
40	2K6-25381-10	AXLE, WHEEL EJE DE RUEDA	1	1	1	
41	95607-14200	NUT, SELF-LOCKING TUERCA DE AUTO-CIERRE	1	1	1	
42	90387-155J5	COLLAR COLLAR	1	1	1	
43	3V6-25388-00	PULLER, CHAIN 1 TIRADOR DE CADENA 1	1	1	1	
44	3V6-25389-00	PULLER, CHAIN 2 TIRADOR DE CADENA 2	1	1	1	

FIG. 33 STEERING HANDLE & CABLE MANILLAR & CABLE

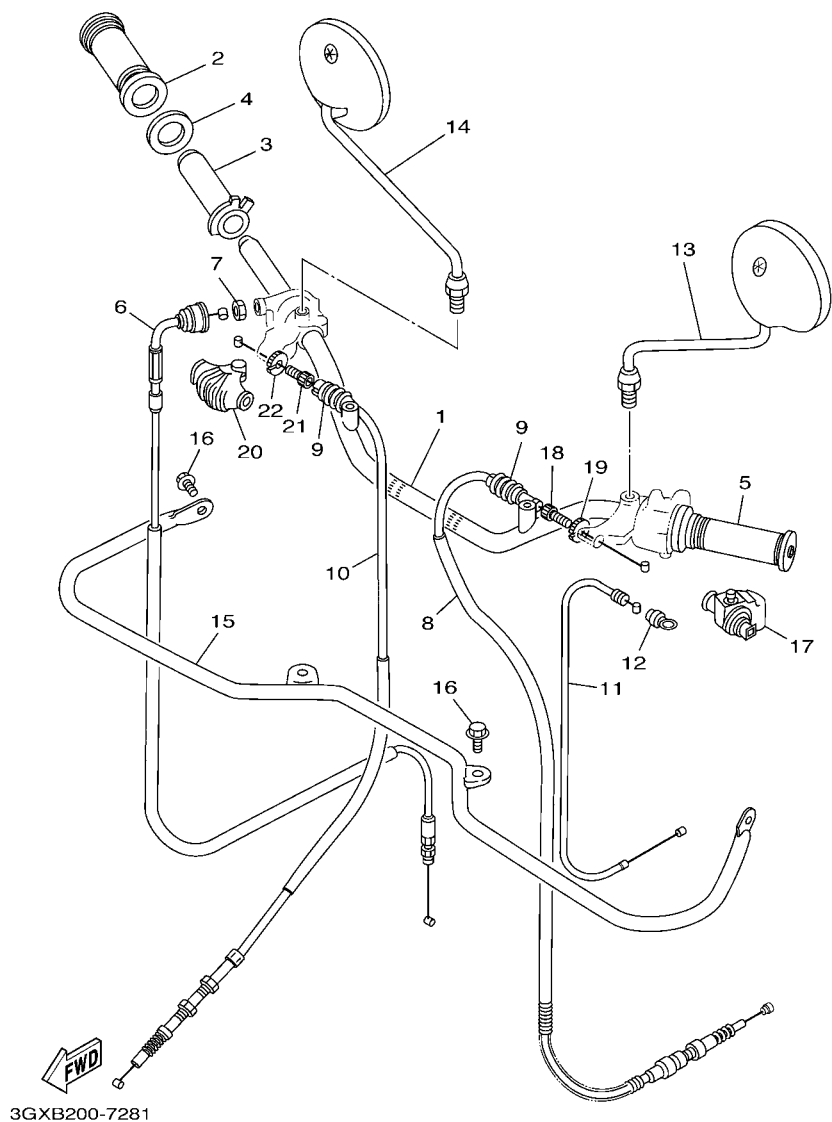

REF. NO.	PART NO. CODIGO Nº	DESCRIPTION DESCRIPCION	3GXL	3GXM	3GXN	REMARKS OBSERVACIONES
1	36X-26111-01	HANDLEBAR MANUBRIO	1	1		UR FOR YNS3 UR PARA YNS3
	36X-26111-11	HANDLEBAR MANUBRIO	1	1		UR FOR SBE UR PARA SBE
2	3V6-26242-00	GRIP (RIGHT) EMPUNADURA (MD)	1	1		
3	434-26243-00	TUBE, THROTTLE GUIDE TUBO DE GUIA DE OBTURADOR	1	1		
4	1M1-26249-01	RING, LEAF ANILLO DE FLEJE	1	1		
5	3V6-26241-00	GRIP (LEFT) EMPUNADURA (MI)	1	1		
6	36X-26311-01	CABLE, THROTTLE 1 CABLE DE ACELERADOR 1	1	1		
7	90170-10038	NUT TUERCA	1	1		
8	1RH-26335-00	CABLE, CLUTCH CABLE DE EMBRAGUE	1	1		
9	1E6-26342-00	BOOT, CABLE FUNDA DE CABLE	2	2		
10	36X-26341-01	CABLE, BRAKE CABLE DE FRENO	1	1		
11	36X-26331-00	CABLE, STARTER 1 CABLE DE ARRANQUE	1	1		
12	5Y1-26339-00	BOOT FUNDA	1	1		
13	1Y1-26290-50	BACK MIRROR ASSY (L.H) ESPEJO COMPLETO (DERECHO)	1	1		
14	1Y1-26290-60	BACK MIRROR ASSY (R.H) ESPEJO COMPLETO (DERECHO)	1	1		
15	36X-26123-01	GUARD, LEVER GUARDA DE PALANCA	1	1		UR FOR YNS3 UR PARA YNS3
	36X-26123-11	GUARD, LEVER GUARDA DE PALANCA	1	1		UR FOR SBE UR PARA SBE
16	95807-08016	BOLT, FLANGE TUERCA DE REBORDE	4	4		
17	36X-26372-00	COVER, HANDLE LEVER 1 CUBIERTA DE PALANCA DE MANUB 1	1	1		
18	90123-08046	BOLT PERNO	1	1		
19	90179-08148	NUT TUERCA	1	1		
20	1E6-26372-00	COVER, HANDLE LEVER 1 CUBIERTA DE PALANCA DE MANUB 1	1	1		
21	90123-08046	BOLT PERNO	1	1		
22	90179-08148	NUT TUERCA	1	1		

FIG. 34 STEERING HANDLE & CABLE 2 MANUBRAR & CABLE 2

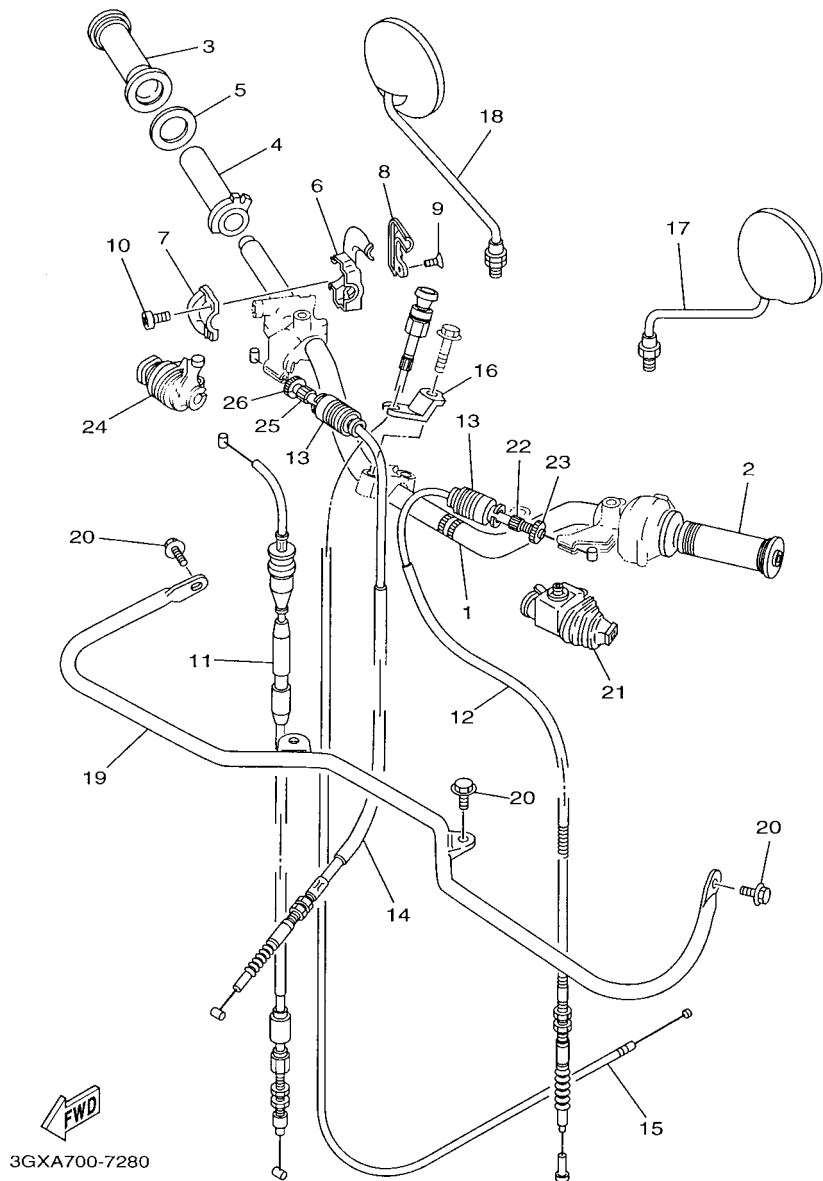

3GXA700-7280

REF. NO.	PART NO. CODIGO Nº	DESCRIPTION DESCRIPCION	3GXL	3GXM	3GXN	REMARKS OBSERVACIONES
1	36X-26111-11	HANDLEBAR MANUBRIO			1	SL SL
2	3V6-26241-00	GRIP (LEFT) EMPUNADURA (MI)			1	
3	3V6-26242-00	GRIP (RIGHT) EMPUNADURA (MD)			1	
4	3GX-26243-00	TUBE, THROTTLE GUIDE TUBO DE GUIA DE OBTURADOR			1	
5	1M1-26249-01	RING, LEAF ANILLO DE FLEJE			1	
6	38V-26281-00-98	CAP, GRIP UPPER TAPA DE EMPUNADURA SUPERIOR			1	LGB LGB
7	493-26282-00-98	CAP, GRIP LOWER TAPA DE EMPUNADURA INFERIOR			1	LGB LGB
8	38V-2628H-00	CAP, WIRE TAPA CABLE			1	
9	98707-04012	SCREW, FLAT HEAD TORNILLO DE CABEZA PLANA			2	
10	98507-05016	SCREW, PAN HEAD TORNILLO DE CABEZA PLANA			2	
11	36X-26311-11	CABLE, THROTTLE 1 CABLE DE ACELERADOR 1			1	
12	1RH-26335-00	CABLE, CLUTCH CABLE DE EMBRAGUE			1	
13	1E6-26342-00	BOOT, CABLE FUNDA DE CABLE			2	
14	36X-26341-11	CABLE, BRAKE CABLE DE FRENO			1	
15	36X-26331-10	CABLE, STARTER 1 CABLE DE ARRANQUE			1	
16	4BE-2637G-00	HOLDER, WIRE SOSTEN, DE CABLE			1	
17	1Y1-26290-50	BACK MIRROR ASSY (L.H) ESPEJO COMPLETO (DERECHO)			1	
18	1Y1-26290-60	BACK MIRROR ASSY (R.H) ESPEJO COMPLETO (DERECHO)			1	
19	36X-26123-11	GUARD, LEVER GUARDA DE PALANCA			1	SL SL
20	95807-08016	BOLT, FLANGE TUERCA DE REBORDE			4	
21	36X-26372-00	COVER, HANDLE LEVER 1 CUBIERTA DE PALANCA DE MANUB 1			1	
22	90123-08046	BOLT PERNO			1	
23	90179-08148	NUT TUERCA			1	
24	1E6-26372-00	COVER, HANDLE LEVER 1 CUBIERTA DE PALANCA DE MANUB 1			1	
25	90123-08046	BOLT PERNO			1	
26	90179-08148	NUT TUERCA			1	

FIG. 35 STAND & FOOTREST

SOPORTE & APOYAPIE

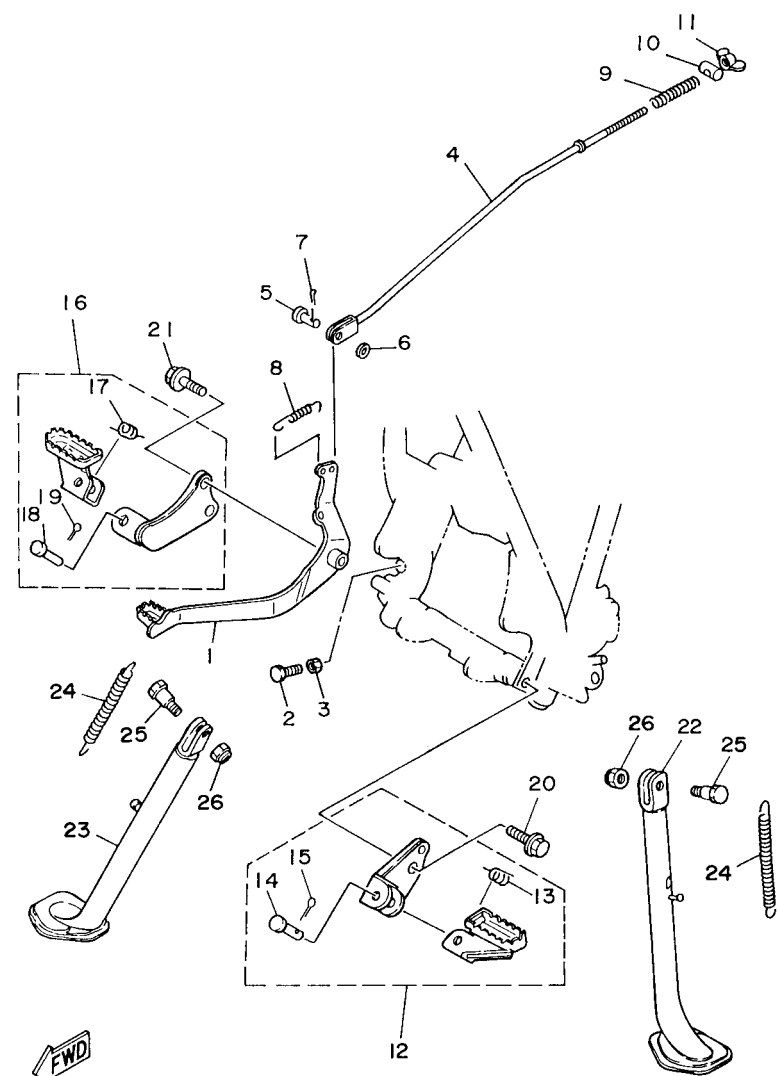

36X700-3290

REF. NO.	PART NO. CODIGO Nº	DESCRIPTION DESCRIPCION	3GXL	3GXM	3GXN	REMARKS OBSERVACIONES
1	36X-27211-00-90	PEDAL, BRAKE PEDAL DE FRENO	1	1	1	ZK ZK
2	97007-06020	BOLT PERNO	1	1	1	
3	95307-06700	NUT TUERCA	1	1	1	
4	36X-27231-00	ROD, BRAKE VARILLA DE FRENO	1	1	1	
5	90240-06076	PIN, CLEVIS PASADOR CON HOYO	1	1	1	
6	92907-06200	WASHER ARANDELA	1	1	1	
7	91401-20012	PIN, COTTER PASADOR DE CHAVETA	1	1	1	
8	90506-14343	SPRING, TENSION RESORTE DE TENSION	1	1	1	
9	90501-10245	SPRING, COMPRESSION RESORTE DE COMPRESION	1	1	1	
10	90249-12008	PIN PASADOR	1	1	1	
11	90175-06013	NUT, WING TUERCA MARIPOSA	1	1	1	
12	36X-27410-00-90	FRONT FOOTREST ASSY (LEFT) APOYAPIE DELANTERO (MI)	1	1	1	ZK ZK
13	90508-20023	.SPRING, TORSION .RESORTE DE TORSION	1	1	1	
14	91701-08038	.PIN, CLEVIS .PASADOR DE ABRAZADERA	1	1	1	
15	91401-25015	.PIN, COTTER .PASADOR DE CHAVETA	1	1	1	
16	36X-27420-00-90	FRONT FOOTREST ASSY (RIGHT) APOYAPIE DELANTERO (MD)	1	1	1	ZK ZK
17	90508-20023	.SPRING, TORSION .RESORTE DE TORSION	1	1	1	
18	91701-08038	.PIN, CLEVIS .PASADOR DE ABRAZADERA	1	1	1	
19	91401-25015	.PIN, COTTER .PASADOR DE CHAVETA	1	1	1	
20	95827-12025	BOLT, FLANGE TUERCA DE REBORDE	1	1	1	
21	90105-10058	BOLT, FLANGE TORNILLO	2	2	2	
22	36X-27311-01	STAND, SIDE PUNTAL LATERAL	1	1	1	
23	36X-27311-11	STAND, SIDE PUNTAL LATERAL	1	1	1	
24	90506-28100	SPRING, TENSION RESORTE DE TENSION	2	2	2	
25	90109-10473	BOLT PERNO	2	2	2	
26	90185-10037	NUT, SELF-LOCKING TUERCA AUTOBLOCANTE	2	2	2	

FIG. 37 GENERATOR 2

GENERADOR 2

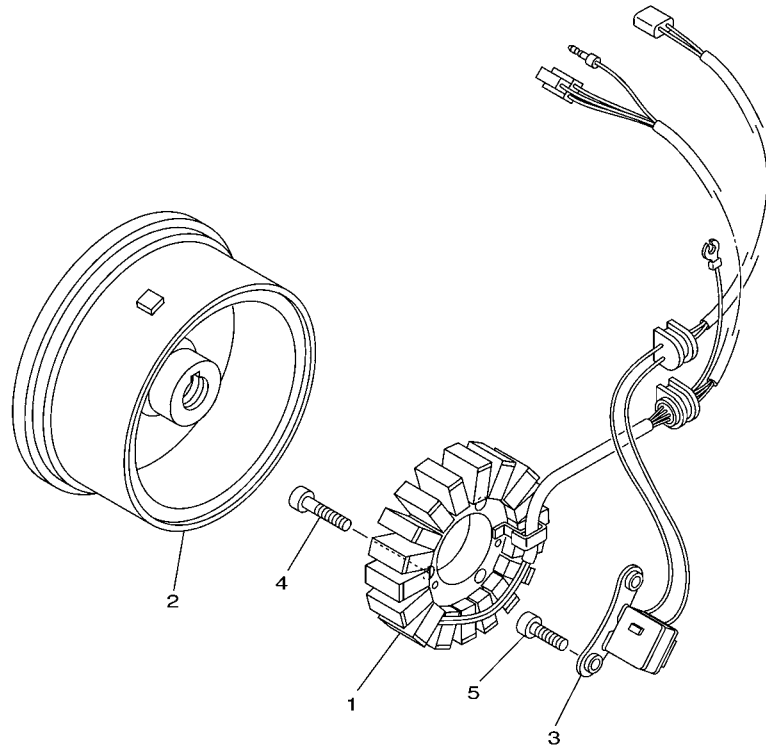

REF. NO.	PART NO. CODIGO Nº	DESCRIPTION DESCRIPCION	3GXL	3GXM	3GXN	REMARKS OBSERVACIONES
1	3GX-81410-00	STATOR ASSY ESTATOR COMPLETO			1	
2	5MP-85550-00	ROTOR ASSY ROTOR COMPLETO			1	
3	4JG-85580-01	COIL, PULSER BOBINA DE PULSACION			1	
4	91317-06025	BOLT PERNO			3	
5	91317-06020	BOLT PERNO			2	

3GXF700-B301

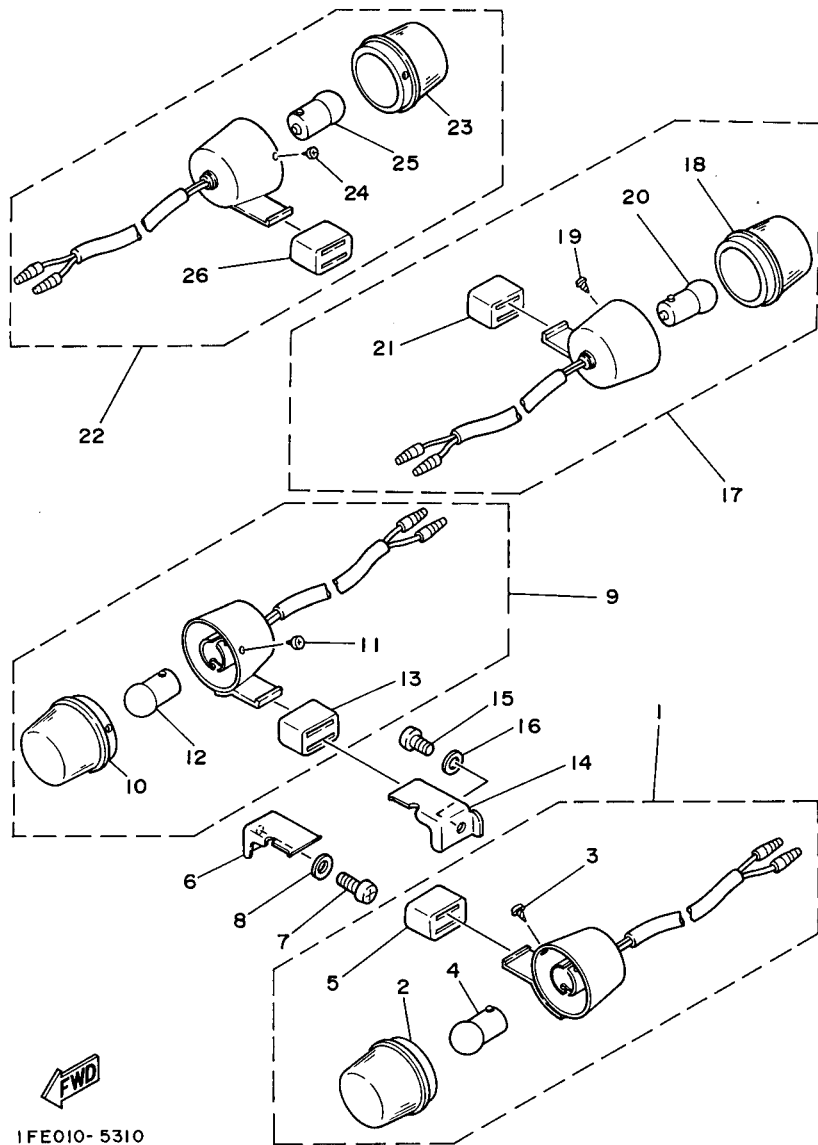

1FE010-5310

FIG. 39 FLASHER LIGHT

LUZ DE DESTELLADOR

REF. NO.	PART NO. CODIGO Nº	DESCRIPTION DESCRIPCION	3GXL	3GXM	3GXN	REMARKS OBSERVACIONES
1	36X-83310-20	FRONT FLASHER LIGHT ASSY 1 DESTELLADOR DE LUZ DELANT.	1	1		
2	36X-83312-00	.LENS, FLASHER .LENTE DE DESTELLADOR	1	1		
3	97706-30108	.SCREW, TAPPING .TORNILLO, ROSCA CHAPA	1	1		
4	185-83311-10	.BULB, FLASHER (6V-8W) .BOMBILLA (6V-8W)	1	1		
5	36X-83321-00	.DAMPER, FLASHER 1 .AMORTIGUADOR DE DESTELLADOR 1	1	1		
6	36X-83318-00	STAY, FLASHER 1 SOPORTE DE DESTELLADOR 1	1	1		
7	98507-06016	SCREW, PAN HEAD TORNILLO DE CABEZA CON PLANA	1	1		
8	92907-06600	WASHER, PLATE ARANDELA	1	1		
9	36X-83320-20	FRONT FLASHER LIGHT ASSY 2 DESTELLADOR DE LUZ DELANT.	1	1		
10	36X-83312-00	.LENS, FLASHER .LENTE DE DESTELLADOR	1	1		
11	97706-30108	.SCREW, TAPPING .TORNILLO, ROSCA CHAPA	1	1		
12	185-83311-10	.BULB, FLASHER (6V-8W) .BOMBILLA (6V-8W)	1	1		
13	36X-83321-00	.DAMPER, FLASHER 1 .AMORTIGUADOR DE DESTELLADOR 1	1	1		
14	36X-83328-00	STAY, FLASHER 2 SOPORTE DE DESTELLADOR 2	1	1		
15	98507-06016	SCREW, PAN HEAD TORNILLO DE CABEZA CON PLANA	1	1		
16	92907-06600	WASHER, PLATE ARANDELA	1	1		
17	36X-83330-20	REAR FLASHER LIGHT ASSY 1 DESTELLADOR DE LUZ TRAS.COMPL.	1	1		
18	36X-83312-00	.LENS, FLASHER .LENTE DE DESTELLADOR	1	1		
19	97706-30108	.SCREW, TAPPING .TORNILLO, ROSCA CHAPA	1	1		
20	185-83311-10	.BULB, FLASHER (6V-8W) .BOMBILLA (6V-8W)	1	1		
21	36X-83321-00	.DAMPER, FLASHER 1 .AMORTIGUADOR DE DESTELLADOR 1	1	1		
22	36X-83340-20	REAR FLASHER LIGHT ASSY 2 DESTELLADOR DE LUZ TRAS.COMPL.	1	1		
23	36X-83312-00	.LENS, FLASHER .LENTE DE DESTELLADOR	1	1		
24	97706-30108	.SCREW, TAPPING .TORNILLO, ROSCA CHAPA	1	1		
25	185-83311-10	.BULB, FLASHER (6V-8W) .BOMBILLA (6V-8W)	1	1		
26	36X-83321-00	.DAMPER, FLASHER 1 .AMORTIGUADOR DE DESTELLADOR 1	1	1		

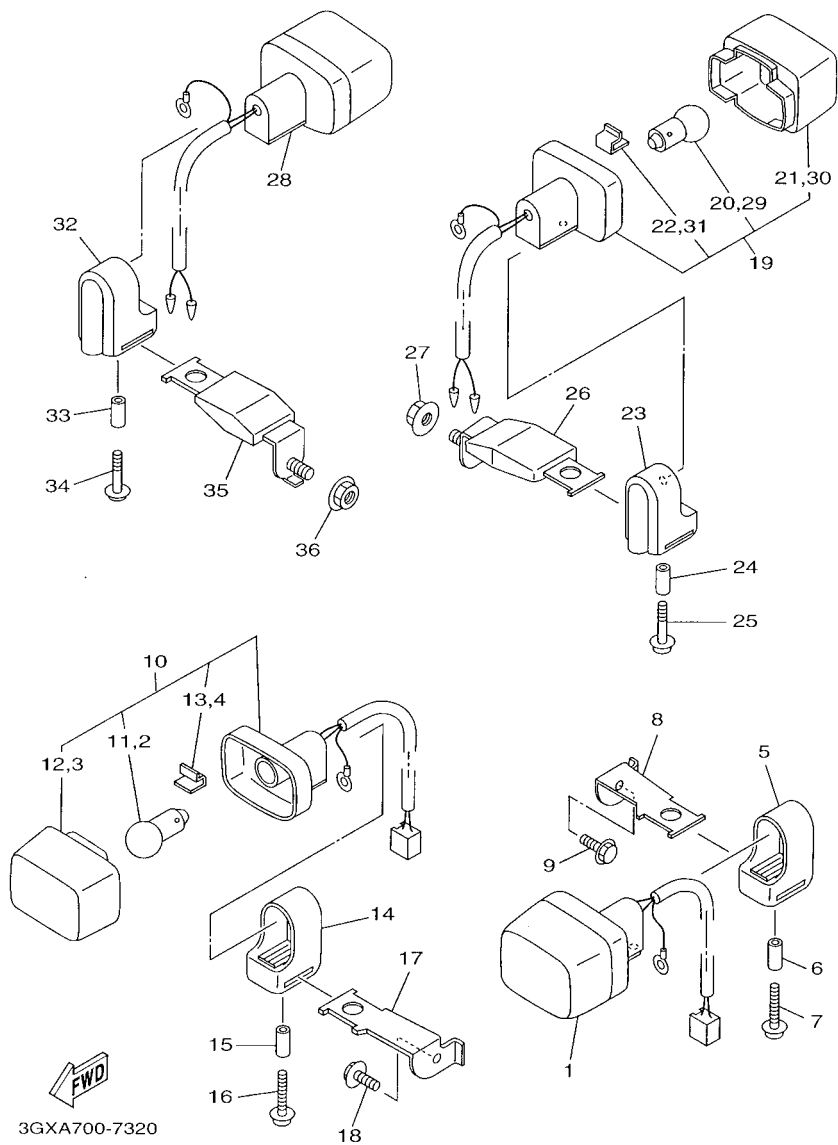

FIG. 40 FLASHER LIGHT 2

LUZ DE DESTELLADOR 2

REF. NO.	PART NO. CODIGO Nº	DESCRIPTION DESCRIPCION	3GXL	3GXM	3GXN	REMARKS OBSERVACIONES
1	1KH-83310-10	FRONT FLASHER LIGHT ASSY 1 DESTELLADOR DE LUZ DELANT.			1	
2	1KH-83311-00	.BULB (12V-10W) .BOMBILLA (12V-10W)			1	
3	2T4-83312-00	.LENS, FLASHER .LENTE DE DESTELLADOR			1	
4	1KH-83345-00	.PLUG, BLIND .TAPON CIEGO			1	
5	1KH-83321-00	DAMPER, FLASHER 1 AMORTIGUADOR DE DESTELLADOR 1			1	
6	90387-05285	COLLAR COLLAR			1	
7	90159-05011	SCREW, WITH WASHER TORNILLO CON VALONA			1	
8	3GX-83318-00	STAY, FLASHER 1 SOPORTE DE DESTELLADOR 1			1	
9	95807-06010	BOLT, FLANGE TUERCA DE REBORDE			1	
10	1KH-83320-10	FRONT FLASHER LIGHT ASSY 2 DESTELLADOR DE LUZ DELANT.			1	
11	1KH-83311-00	.BULB (12V-10W) .BOMBILLA (12V-10W)			1	
12	2T4-83312-00	.LENS, FLASHER .LENTE DE DESTELLADOR			1	
13	1KH-83345-00	.PLUG, BLIND .TAPON CIEGO			1	
14	1KH-83321-00	DAMPER, FLASHER 1 AMORTIGUADOR DE DESTELLADOR 1			1	
15	90387-05285	COLLAR COLLAR			1	
16	90159-05011	SCREW, WITH WASHER TORNILLO CON VALONA			1	
17	3GX-83328-00	STAY, FLASHER 2 SOPORTE DE DESTELLADOR 2			1	
18	95807-06010	BOLT, FLANGE TUERCA DE REBORDE			1	
19	3XP-83310-10	FRONT FLASHER LIGHT ASSY 1 DESTELLADOR DE LUZ DELANT.			1	
20	1KH-83311-00	.BULB (12V-10W) .BOMBILLA (12V-10W)			1	
21	2T4-83312-00	.LENS, FLASHER .LENTE DE DESTELLADOR			1	
22	1KH-83345-00	.PLUG, BLIND .TAPON CIEGO			1	
23	1KH-83321-00	DAMPER, FLASHER 1 AMORTIGUADOR DE DESTELLADOR 1			1	
24	90387-05285	COLLAR COLLAR			1	
25	90159-05011	SCREW, WITH WASHER TORNILLO CON VALONA			1	
26	4GY-83368-00	STAY, FLASHER 1 SOPORTE DE DESTELLADOR 1			1	
27	95707-08500	NUT, FLANGE TUERCA DE BRIDA			1	

FIG. 40 FLASHER LIGHT 2

LUZ DE DESTELLADOR 2

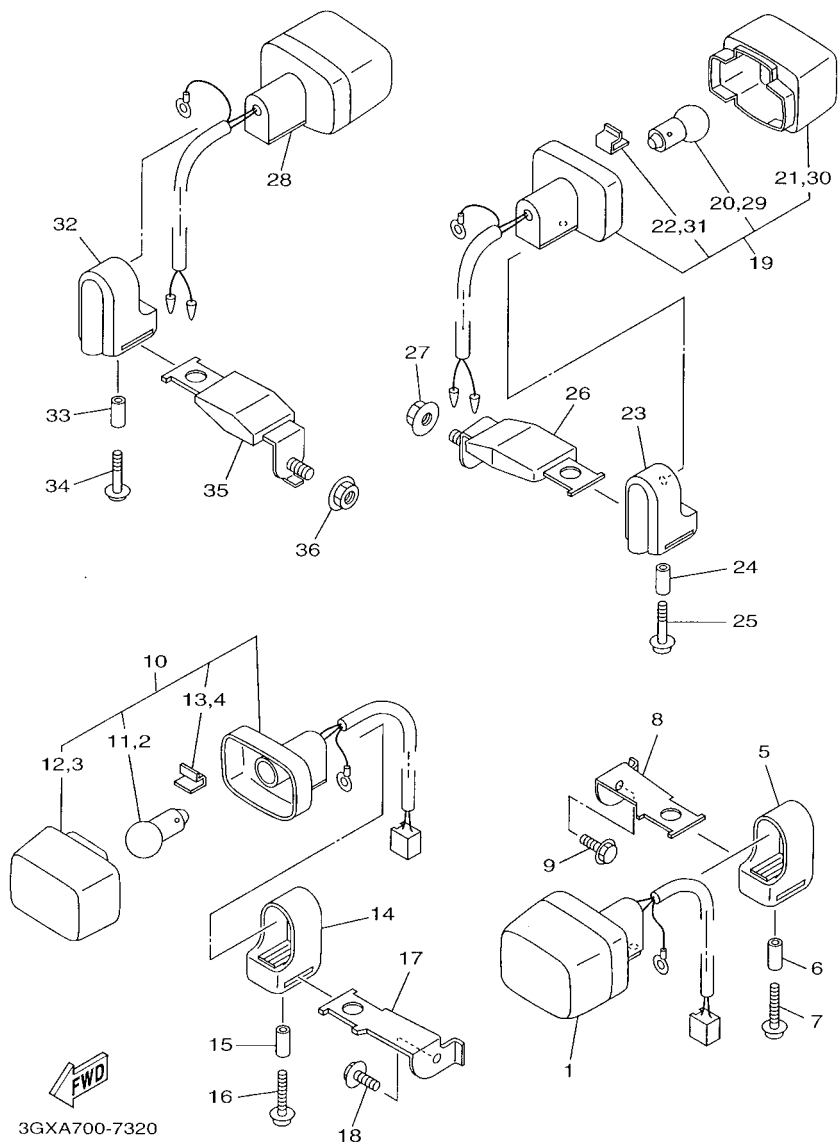

REF. NO.	PART NO. CODIGO Nº	DESCRIPTION DESCRIPCION	3GXL	3GXM	3GXN	REMARKS OBSERVACIONES
28	3XP-83320-10	FRONT FLASHER LIGHT ASSY 2 DESTELLADOR DE LUZ DELANT.			1	
29	1KH-83311-00	.BULB (12V-10W) .BOMBILLA (12V-10W)			1	
30	2T4-83312-00	.LENS, FLASHER .LENTE DE DESTELLADOR			1	
31	1KH-83345-00	.PLUG, BLIND .TAPON CIEGO			1	
32	1KH-83321-00	DAMPER, FLASHER 1 AMORTIGUADOR DE DESTELLADOR 1			1	
33	90387-05285	COLLAR COLLAR			1	
34	90159-05011	SCREW, WITH WASHER TORNILLO CON VALONA			1	
35	4GY-83368-00	STAY, FLASHER 1 SOPORTE DE DESTELLADOR 1			1	
36	95707-08500	NUT, FLANGE TUERCA DE BRIDA			1	

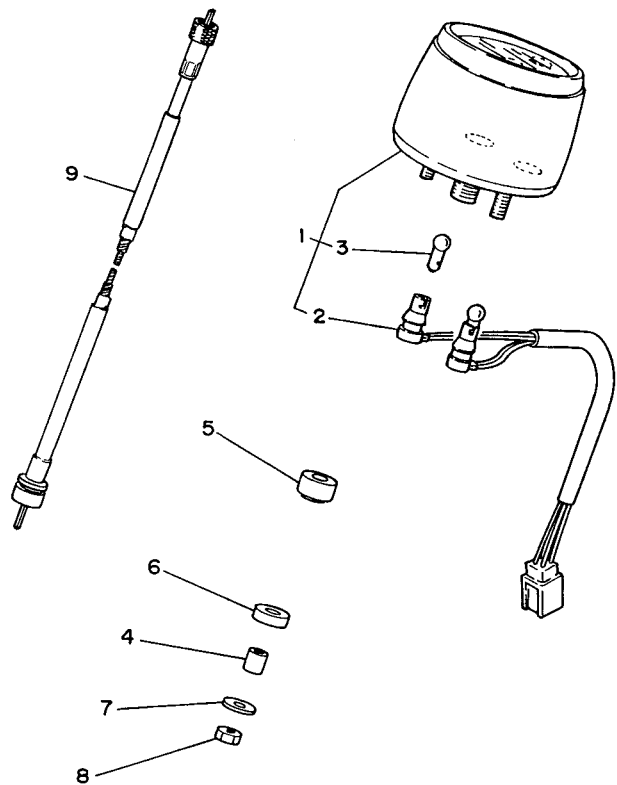

36X700-8320

FIG. 41 METER

MEDIDOR

REF. NO.	PART NO. CODIGO Nº	DESCRIPTION DESCRIPCION	3GXL	3GXM	3GXN	REMARKS OBSERVACIONES
1	3HA-83510-00	SPEEDOMETER ASSY VELOCIMETRO COMPL.	1	1		
	3GX-83510-00	SPEEDOMETER ASSY VELOCIMETRO COMPL.			1	
2	2W0-83520-00	.SOCKET CORD ASSY .ENCASTRE COMPLETO	1	1		
	3GX-83520-00	.SOCKET CORD ASSY .ENCASTRE COMPLETO			1	
3	4N0-83516-00	.BULB (6V-3W) .AMPOLLETA (6V-3W)	2	2		
	1YT-83517-00	.BULB (12V-1.7W T10) .AMPOLLETA (12V-1.7W T10)			2	
4	90387-067V1	COLLAR COLLAR	2	2	2	
5	1M3-83513-00	DAMPER AMORTIGUADOR	2	2	2	
6	355-83526-00	DAMPER 2 AMORTIGUADOR 2	2	2	2	
7	355-83524-00	WASHER, SPECIAL ARANDELA ESPECIAL	2	2	2	
8	95307-06600	NUT TUERCA	2	2	2	
9	36X-83550-00	SPEEDOMETER CABLE ASSY CABLE DE VELOCIMETRO COMPLETO	1	1		
	47J-83550-00	SPEEDOMETER CABLE ASSY CABLE DE VELOCIMETRO COMPLETO			1	

FIG. 42 HEADLIGHT

FARO DELANTERO

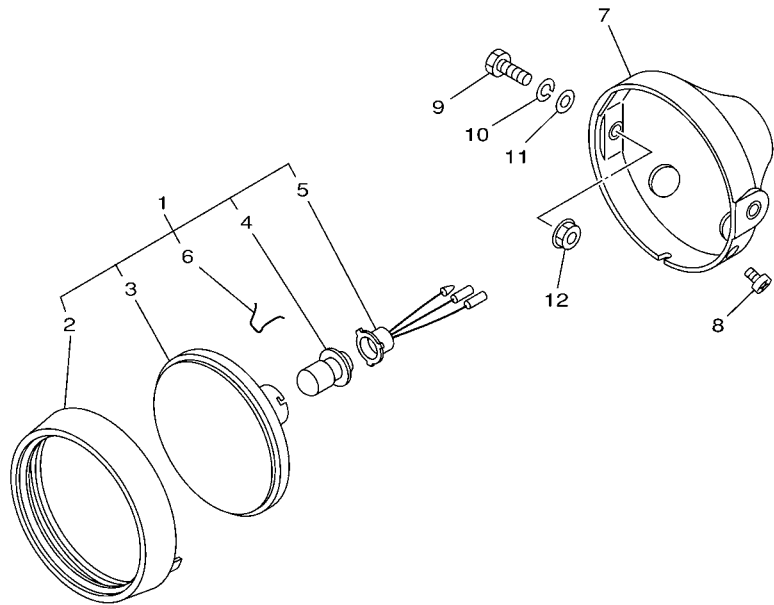

REF. NO.	PART NO. CODIGO Nº	DESCRIPTION DESCRIPCION	3GXL	3GXM	3GXN	REMARKS OBSERVACIONES
1	3M7-84110-00	HEADLIGHT UNIT ASSY UNIDAD FARO DELANTERO COMPLETO	1	1		
2	202-84315-00	.RIM, HEADLIGHT .ARO DE FARO DELANTERO	1	1		
3	276-84120-00	.LENS ASSY .LENTES COMPLETO	1	1		
4	248-84114-00	.BULB, HEADLIGHT (6V-25/25W) .AMPOLLETA (6V-25/25W)	1	1		YELLOW AMARILLO
5	317-84112-30	.SOCKET .ENCASTRE	1	1		
6	195-84324-00	.SPRING, REFLECTOR .RESORTE DE REFLECTOR	3	3		
7	3M7-84130-00	BODY ASSY, HEADLIGHT CUERPO COMPL FARO DELANTERO	1	1		
8	98507-05012	SCREW, PAN HEAD TORNILLO DE CABEZA PLANA	1	1		
9	97007-08025	BOLT PERNO	2	2		
10	92907-08100	WASHER, SPRING ARANDELA	2	2		
11	92907-08600	WASHER, PLATE ARANDELA	2	2		
12	95707-08500	NUT, FLANGE TUERCA DE BRIDA	2	2		



3GXB200-7330

FIG. 43 HEADLIGHT 2

FARO DELANTERO 2

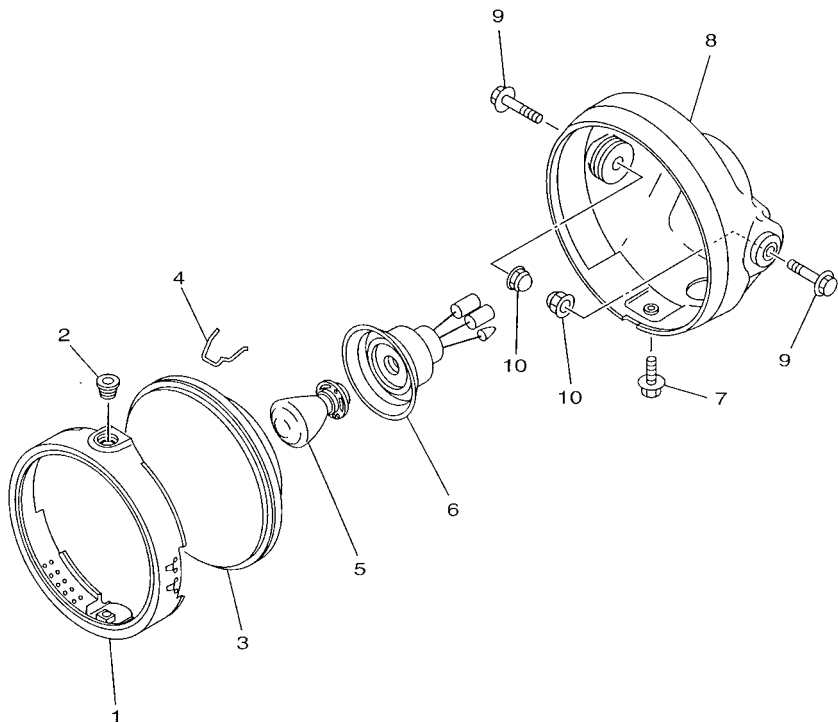

REF. NO.	PART NO. CODIGO Nº	DESCRIPTION DESCRIPCION	3GXL	3GXM	3GXN	REMARKS OBSERVACIONES
1	3J0-84195-60	RING, RETAINING ANILLO DE RETEN			1	
2	1M1-84133-60	COLLAR, SCREW COLLAR DE TORNILLO			1	
3	4F2-84120-00	LENS ASSY LENTES COMPLETO			1	
4	148-84324-00	SPRING, REFLECTOR RESORTE DE REFLECTOR			3	
5	1A0-84314-01	BULB (12V-45/45W) BOMBILLA (12V-45/45W)			1	
6	3GX-84112-00	SOCKET ENCASTRE			1	
7	1M1-84137-60	BOLT, SPECIAL PERNO ESPECIAL			1	
8	3J0-84130-60	BODY ASSY, HEADLIGHT CUERPO COMPL FARO DELANTERO			1	BLACK NEGRO
9	95807-08030	BOLT, FLANGE TUERCA DE REBORDE			2	
10	90176-08068	NUT, CROWN TUERCA CORONA			2	

3GXA700-7340

FIG. 45 TAILLIGHT 2

LUZ DE COLA 2

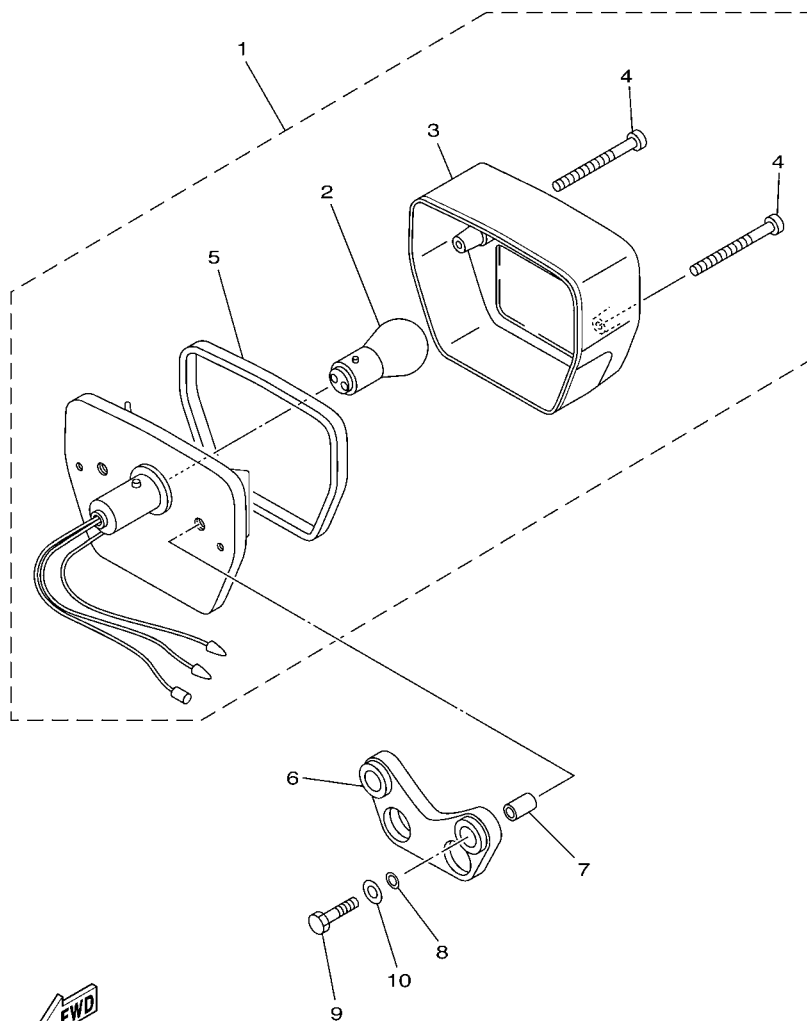

3GXA700-7351

REF. NO.	PART NO. CODIGO Nº	DESCRIPTION DESCRIPCION	3GXL	3GXM	3GXN	REMARKS OBSERVACIONES
1	1KH-84710-00	TAILLIGHT UNIT ASSY CONJT. FARO TRASERO			1	
2	34X-84714-00	.BULB (12V-21/5W) .BOMBILLA (12V-21/5W)			1	
3	1FE-84521-00	.LENS, TAILLIGHT .LENTE DE FARO TRASERO			1	
4	98511-03045	.SCREW, PAN HEAD .TORNILLO, DE CABEZA CRUZADA			2	
5	1KH-84723-00	.GASKET, TAIL LENS .EMPAQUE LENTE FARO TRASERO			1	
6	36X-84527-00	DAMPER AMORTIGUADOR			1	
7	90387-05563	COLLAR COLLAR			2	
8	90201-054K4	WASHER, PLATE ARANDELA PLANA			2	
9	97007-05020	BOLT PERNO			2	
10	92907-05600	WASHER, PLATE ARANDELA			2	

FIG. 46 HANDLE SWITCH & LEVER

INTERRUPTOR DE MANILLAR&PALANC

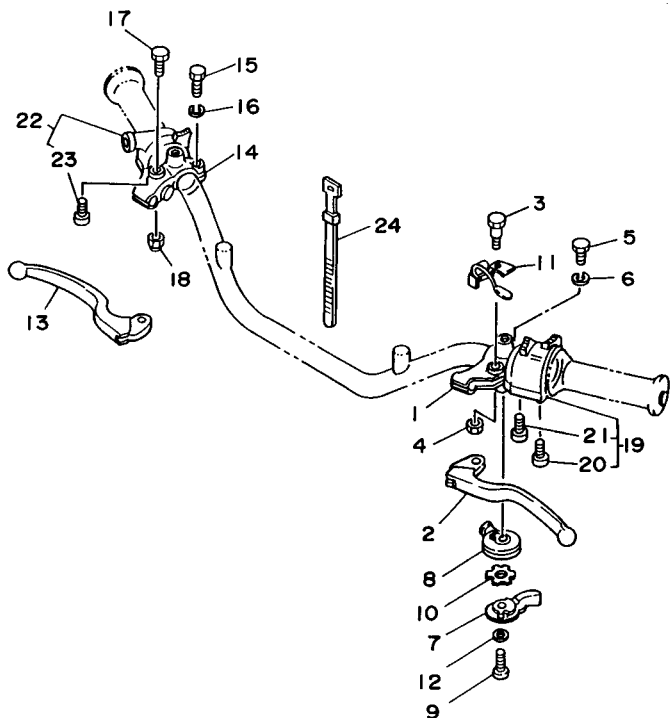

3GX9700-6350

REF. NO.	PART NO. CODIGO Nº	DESCRIPTION DESCRIPCION	3GXL	3GXM	3GXN	REMARKS OBSERVACIONES
1	5Y1-82911-01	HOLDER, LEVER 1 SOPORTE DE LEVA 1	1	1		
2	4GY-83912-00	LEVER 1 PALANCA 1	1	1		
3	90109-06799	BOLT PERNO	1	1		
4	95607-06100	NUT, U TUERCA AUTOBLOCANTE	1	1		
5	97007-06022	BOLT PERNO	1	1		
6	92907-06100	WASHER, SPRING ARANDELA	1	1		
7	5Y1-83941-00	LEVER, STARTER PALANCA DE ARRANQUE	1	1		
8	5Y1-83942-00	COVER, STARTER CUBIERTA DE ARRANQUE	1	1		
9	90153-06042	SCREW, HEXAGON TORNILLO HEXAGONAL	1	1		
10	90209-10131	WASHER ARANDELA DE SEPARACION	1	1		
11	36X-83965-00	LEVER, LOCK PALANCA DE CIERRE	1	1		
12	92907-06200	WASHER ARANDELA	1	1		
13	23X-83922-00	LEVER 2 PALANCA 2	1	1		
14	361-82921-31	HOLDER, LEVER 2 SOPORTE DE LEVA 2	1	1		
15	97007-06022	BOLT PERNO	1	1		
16	92907-06100	WASHER, SPRING ARANDELA	1	1		
17	90109-06799	BOLT PERNO	1	1		
18	95607-06100	NUT, U TUERCA AUTOBLOCANTE	1	1		
19	36X-83972-01	SWITCH, HANDLE 4 INTERRUPTOR DE MANIJA 4	1	1		
20	98506-05025	.SCREW, PAN HEAD .TORNILLO, DE CABEZA CRUZADA	1	1		
21	98506-05030	.SCREW, PAN HEAD .TORNILLO, DE CABEZA CRUZADA	1	1		
22	18G-83976-00	SWITCH, HANDLE 1 INTERRUPTOR MANIJA 1	1	1		
23	90157-05027	.SCREW, PAN HEAD .TORNILLO CABEZA CONICA PLANA	2	2		
24	437-83936-01	BAND, SWITCH CORD BANDA DE CABLE DE INTERRUPTOR	4	4		

FIG. 47 HANDLE SWITCH & LEVER 2 INTERRUPTOR DE MANILLAR&PALANC

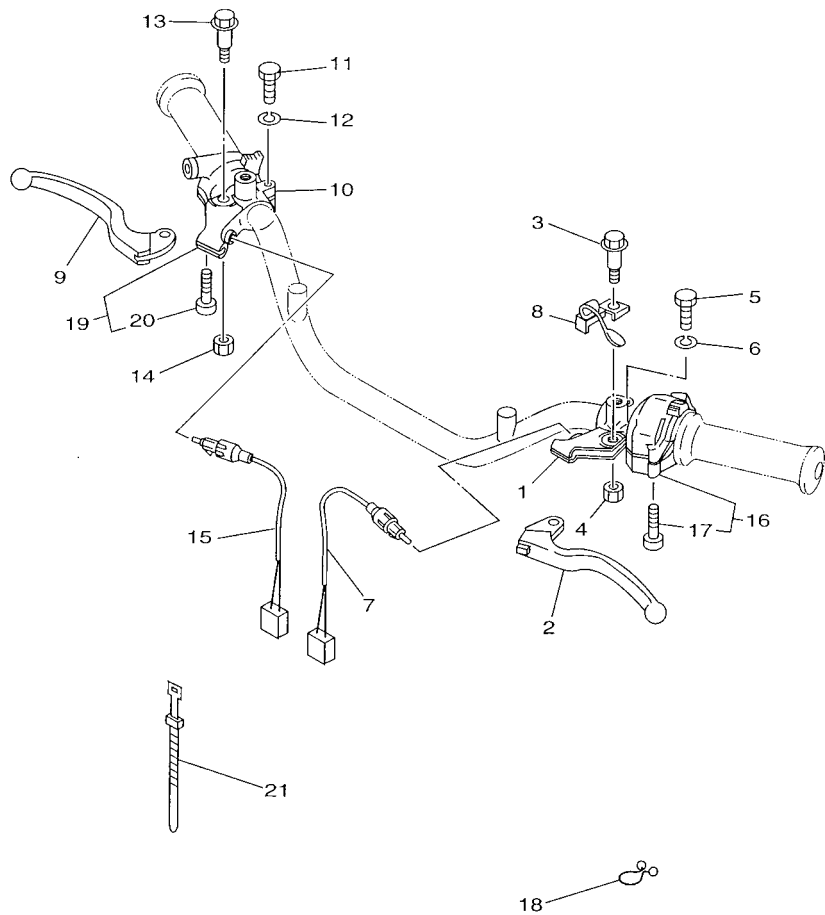

3GXA700-7360

REF. NO.	PART NO. CODIGO Nº	DESCRIPTION DESCRIPCION	3GXL	3GXM	3GXN	REMARKS OBSERVACIONES
1	3Y6-82911-00	HOLDER, LEVER 1 SOPORTE DE LEVA 1			1	
2	4GY-83912-00	LEVER 1 PALANCA 1			1	
3	90109-06799	BOLT PERNO			1	
4	95607-06100	NUT, U TUERCA AUTOBLOCANTE			1	
5	97007-06022	BOLT PERNO			1	
6	92907-06100	WASHER, SPRING ARANDELA			1	
7	3MW-82917-00	SWITCH INTERRUPTOR			1	
8	36X-83965-00	LEVER, LOCK PALANCA DE CIERRE			1	
9	23X-83922-00	LEVER 2 PALANCA 2			1	
10	1JN-82921-00	HOLDER, LEVER 2 SOPORTE DE LEVA 2			1	
11	97007-06022	BOLT PERNO			1	
12	92907-06100	WASHER, SPRING ARANDELA			1	
13	90109-06799	BOLT PERNO			1	
14	95607-06100	NUT, U TUERCA AUTOBLOCANTE			1	
15	3AB-83980-00	FRONT STOP SWITCH ASSY INTERRUP.PARADA DELANTERO			1	
16	3GX-83972-10	SWITCH, HANDLE 4 INTERRUPTOR DE MANIJA 4			1	
17	98507-05030	.SCREW, PAN HEAD .TORNILLO DE CABEZA PLANA			2	
18	90464-23041	CLAMP BRIDA			2	
19	4DW-83975-11	SWITCH, HANDLE 2 INTERRUPTOR MANIJA 2			1	
20	98507-05018	.SCREW, PAN HEAD .TORNILLO DE CABEZA PLANA			2	
21	437-83936-01	BAND, SWITCH CORD BANDA DE CABLE DE INTERRUPTOR			4	

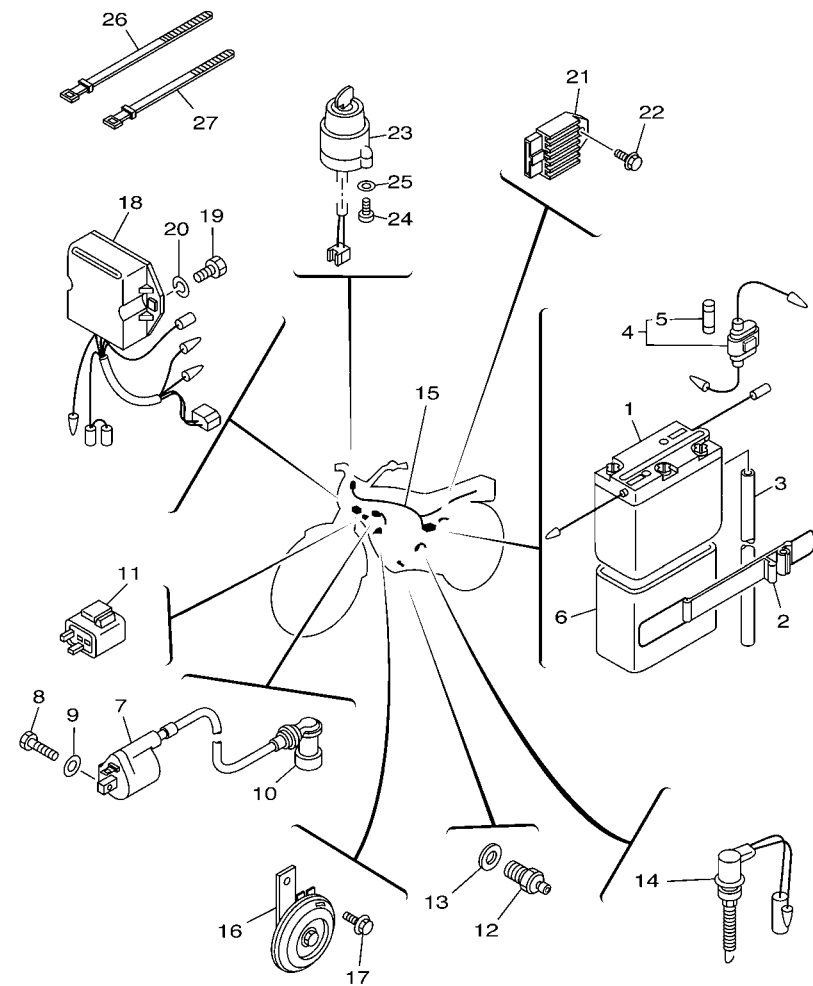

3GXL200-D480

FIG. 48 ELECTRICAL 1

EQUIPO ELECTRICO 1

REF. NO.	PART NO. CODIGO Nº	DESCRIPTION DESCRIPCION	3GXL	3GXM	3GXN	REMARKS OBSERVACIONES
1	558-82110-12	BATTERY ASSY (GS 6N4B-2A-3) BATERIA COMPLETA(GS 6N4B-2A-3)	1	1		
2	36X-82131-00	BAND, BATTERY TIRANTE DE BATERIA	1	1		
3	90445-08171	HOSE (L375) TUBO (L375)	1	1		
4	55K-82150-01	FUSE HOLDER ASSY PORTA-FUSIBLES COMPLETO	1	1		
5	116-82151-00	.FUSE (10A) .FUSIBLE (10A)	2	2		
6	36X-82122-00	SEAT, BATTERY ASIENTO DE BATERIA	1	1		
7	3KJ-82310-10	IGNITION COIL ASSY BOBINA DE ENCENDIDO COMPLETA	1	1		
8	97007-06020	BOLT PERNO	2	2		
9	92907-06600	WASHER, PLATE ARANDELA	2	2		
10	55X-82370-00	PLUG CAP ASSY TAPON DE BUJIA COMPLT	1	1		
11	36X-83350-10	FLASHER RELAY ASSY RELE DE DESTELLADOR COMPL.	1	1		
12	4KM-82540-00	NEUTRAL SWITCH ASSY INTERRUPTOR NEUTRAL COMPL	1	1		
13	90430-10148	GASKET JUNTA	1	1		
14	2F1-82530-02	STOP SWITCH ASSY INTERRUPTOR DE PARADA COMPLETO	1	1		
15	36X-82590-20	WIRE HARNESS ASSY CONJUNTO DE CABLES	1	1		
16	36X-83371-11	HORN BOCINA	1	1		
17	95807-06012	BOLT, FLANGE TUERCA DE REBORDE	1	1		
18	12V-85540-10	C.D.I. UNIT ASSY UNIDAD C.D.I. COMPLETA	1	1		
19	97007-06016	BOLT PERNO	2	2		
20	92907-06100	WASHER, SPRING ARANDELA	2	2		
21	18A-81960-70	RECTIFIER & REGULATOR ASSY RECTIFICADOR Y REGULADOR	1	1		
22	95807-06025	BOLT, FLANGE TUERCA DE REBORDE	1	1		
23	36X-82510-02	MAIN SWITCH ASSY CONJUNTO DE LLAVE IGNICION	1	1		
24	98507-05012	SCREW, PAN HEAD TORNILLO DE CABEZA PLANA	2	2		
25	92907-05600	WASHER, PLATE ARANDELA	2	2		
26	437-83936-11	BAND, SWITCH CORD BANDA DE CABLE DE INTERRUPTOR	1	1		
27	3TB-83936-00	BAND, SWITCH CORD BANDA DE CABLE DE INTERRUPTOR	3	3		

FIG. 49 ELECTRICAL 2

EQUIPO ELECTRICO 2

REF. NO.	PART NO. CODIGO Nº	DESCRIPTION DESCRIPCION	3GXL	3GXM	3GXN	REMARKS OBSERVACIONES
1	4TP-82100-10	BATTERY (GS GT6B-3) BATERIA COMPLETA (GS GT6B-3)			1	
2	55K-82150-01	FUSE HOLDER ASSY PORTA-FUSIBLES COMPLETO			1	
3	116-82151-00	.FUSE (10A) .FUSIBLE (10A)			2	
4	3TJ-81960-02	RECTIFIER & REGULATOR ASSY RECTIFICADOR Y REGULADOR			1	
5	8U9-77162-00	STRIP, WEATHER 2 FRANJA DE CLIMA 2			1	
6	98507-06025	SCREW, PAN HEAD TORNILLO DE CABEZA PLANA			2	
7	4GY-83350-00	FLASHER RELAY ASSY RELE DE DESTELLADOR COMPL.			1	
8	2F1-82530-02	STOP SWITCH ASSY INTERRUPTOR DE PARADA COMPLETO			1	
9	3GX-82590-10	WIRE HARNESS ASSY CONJUNTO DE CABLES			1	
10	3TY-83371-11	HORN BOCINA			1	
11	95807-06012	BOLT, FLANGE TUERCA DE REBORDE			1	
12	3GX-85540-10	C.D.I. UNIT ASSY UNIDAD C.D.I. COMPLETA			1	
13	3GX-85546-00	BAND BANDA			1	
14	4JG-82310-00	IGNITION COIL ASSY BOBINA DE ENCENDIDO COMPLETA			1	
15	95027-06016	BOLT, FLANGE PERNO, DE BRIDA			2	
16	3NS-82370-00	PLUG CAP ASSY TAPON DE BUJIA COMPLT			1	
17	4KM-82540-00	NEUTRAL SWITCH ASSY INTERRUPTOR NEUTRAL COMPL			1	
18	90430-10148	GASKET JUNTA			1	
19	36X-82510-02	MAIN SWITCH ASSY CONJUNTO DE LLAVE IGNICION			1	
20	98507-05012	SCREW, PAN HEAD TORNILLO DE CABEZA PLANA			2	
21	92907-05600	WASHER, PLATE ARANDELA			2	
22	5Y9-12491-00	CLAMP 1 GRAMPA 1			4	
23	90465-13152	CLAMP BRIDA			4	
24	1RL-81950-92	RELAY ASSY RELE COMPLETO			1	
25	4FU-81940-01	STARTER RELAY ASSY CONJUNTO ARRANCADOR RELEVO			1	
26	2GH-82151-00	.FUSE (20A-BL) .FUSIBLE (20A-BL)			1	
27	95027-06008	BOLT, FLANGE PERNO, DE BRIDA			2	

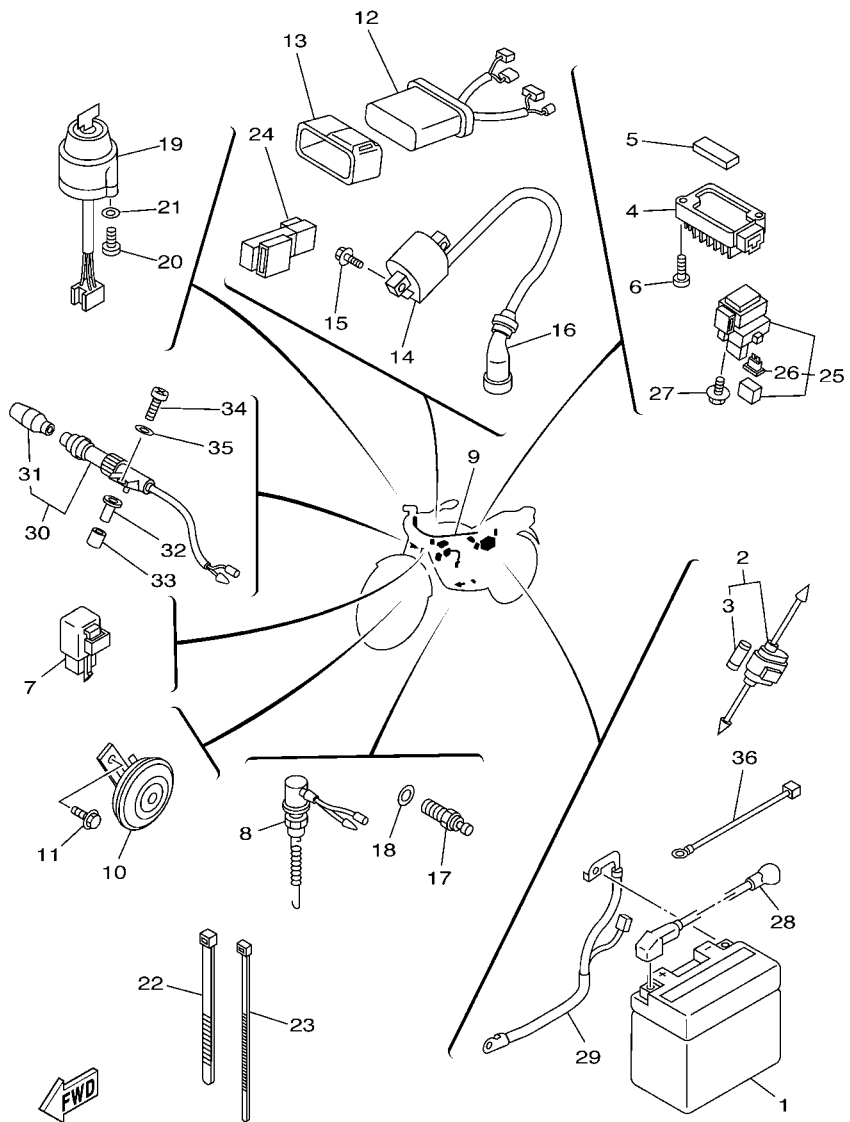

3GXF700-B370



NUMERICAL INDEX
INDICE NUMERICO

PART NO. CODIGO N°	REF. NO.	PART NO. CODIGO N°	REF. NO.	PART NO. CODIGO N°	REF. NO.	PART NO. CODIGO N°	REF. NO.	PART NO. CODIGO N°	REF. NO.	PART NO. CODIGO N°	REF. NO.	PART NO. CODIGO N°	REF. NO.
36X-11102-04	1 - 1	5H0-12176-00	5 - 2	4BE-14613-00	9 - 18	36X-15621-02	14 - 16	36X-18540-00	17 - 1	1YW-22216-00	24 - 4		
5H0-1111F-00	1 - 20	3GC-12210-10	5 - 10	36X-14628-01	9 - 3	36X-15641-00	13 - 8	136-18542-00	17 - 2	3R4-22226-00	24 - 2		
5H0-11133-11	1 - 2	4FM-12213-00	5 - 11	36X-14711-01	9 - 7		14 - 8	36X-21107-00	29 - 8	36X-22310-00-35	23 - 14		
15A-11161-01	2 - 9	5H0-12231-00	5 - 8	3YF-14714-00	9 - 15	15A-15651-01	13 - 12	3GX-21110-00-33	19 - 1	148-22315-00	23 - 20		
15A-11162-00	2 - 7	5NO-12241-00	5 - 9	36X-14728-00	9 - 8		14 - 12	3GX-21110-10-33	20 - 1	36X-22318-00	23 - 28		
5H0-11162-00	2 - 8	36X-12283-00	1 - 25	36X-14752-02	9 - 12	36X-15660-01	13 - 1	3GX-21287-00	20 - 17	36X-22323-00	23 - 26		
36X-11166-00	10 - 11	36X-12288-01	5 - 15	4BD-14766-00	9 - 4		14 - 1	3GX-21287-10	19 - 17	36X-22324-00	23 - 24		
371-11167-01	10 - 3	36X-12292-00	1 - 24		9 - 9	15A-15666-00	13 - 4	36X-21315-00	19 - 7	36X-22325-00	23 - 23		
1NU-11181-00	1 - 6	5Y9-12491-00	49 - 22	36X-14901-01	8 - 1		14 - 4		20 - 7	36X-22327-01	23 - 31		
3RW-11185-00	1 - 12	5H0-13300-02	6 - 1	36X-1490J-00	8 - 5	401-15676-00	13 - 3	36X-21316-00	19 - 2	36X-22358-00	23 - 21		
4BD-11185-00	1 - 12	36X-13324-00	6 - 17	36X-1490K-00	8 - 27		14 - 3	1RL-21316-00-33	20 - 2	36X-23102-10	26 - 1		
3GC-11186-00	1 - 15	5H0-13326-01	6 - 2	36X-14933-01	8 - 4	36X-16111-00	15 - 1	3GX-2134E-00	20 - 19	36X-23102-20	26 - 1		
5H0-11186-00	1 - 15	4BE-13329-01	6 - 4	25G-14937-00	8 - 31	36X-16150-00	15 - 5	36X-21471-00	19 - 15	36X-23103-10	26 - 20		
36X-11187-00	1 - 16	51Y-13411-00	6 - 6	36X-14940-00	8 - 23	5H0-16154-00	15 - 6	36X-21471-10-35	20 - 15	36X-23103-20	26 - 20		
3GC-11187-00	1 - 16	5H0-13440-00	6 - 10	36X-14941-42	8 - 14	36X-16321-00	15 - 18	36X-21471-20	19 - 15	36X-23106-00-35	26 - 21		
36X-11310-00	2 - 1	3GX-13447-00	6 - 11	46X-14984-00	8 - 11	537-16321-00	15 - 8	36X-21485-00	19 - 16	36X-23107-00-35	26 - 2		
5VC-11351-00	2 - 3	24W-13512-00	7 - 17	4G0-14985-00	8 - 18	137-16324-00	15 - 9		20 - 16	36X-23110-00	26 - 6		
15A-11400-00	3 - 1	16G-13569-00	7 - 3	3F7-14991-00	8 - 13	5H0-16351-00	15 - 10	36X-21511-40	21 - 1		26 - 25		
5H0-11400-01	3 - 1	1HX-13575-00	7 - 6	256-14997-00	8 - 6	5H0-16356-01	15 - 14	36X-21511-60	21 - 1	1U6-23111-M1	26 - 17		
15A-11412-09	3 - 2	36X-13586-01	7 - 1	36X-15100-02	10 - 1	5H0-16357-00	15 - 26	36X-21521-00	21 - 4		26 - 36		
5H0-11412-09	3 - 2	36X-14105-00	8 - 2	3GX-15100-02	10 - 1	1W1-16358-01	15 - 13	36X-21522-00	21 - 5	240-23114-00	26 - 18		
5H0-11422-00	3 - 3	25G-14107-20	8 - 22	5H0-15351-00	6 - 8	36X-16371-00	15 - 7	36X-21611-20	21 - 9		26 - 37		
15A-11454-00	3 - 22	36X-1410A-00	8 - 10	3Y1-15361-00	11 - 23	15A-16380-00	15 - 22	36X-21611-40	21 - 9	2JL-23118-00	26 - 16		
5H0-11496-00	3 - 13	22F-14126-00	8 - 7		12 - 23	1KH-16383-00	15 - 19	36X-21621-00	21 - 11		26 - 35		
5H0-11531-00	3 - 21	812-14137-00	8 - 8	3Y1-15363-00	11 - 21	24W-17121-00	16 - 7	36X-21622-00	21 - 12	36X-23118-00	26 - 16		
5H0-11536-00	3 - 16	4G0-14142-35	8 - 12		12 - 21	24W-17131-00	16 - 5	36X-21629-01	21 - 13		26 - 35		
15A-11603-00	3 - 9	36X-14146-00	8 - 20	36X-15378-00	11 - 24	36X-17141-01	16 - 2	36X-21711-20	22 - 1	36X-23141-00	26 - 14		
15A-11605-00	3 - 9	137-14153-00	8 - 15	36X-15411-00	11 - 1	36X-17151-00	16 - 6	36X-21711-40	22 - 1		26 - 33		
15A-11607-00	3 - 9	36X-14153-00	8 - 17	4WP-15411-02	12 - 1	36X-17211-00	16 - 18	36X-21721-20	22 - 2	3R2-23144-00	26 - 5		
36X-11631-00-A0	3 - 8	36X-14169-00	8 - 9	36X-15421-01	11 - 13	36X-17221-01	16 - 12	36X-21721-40	22 - 2		26 - 24		
15A-11633-00	3 - 10	537-14186-00	8 - 21		12 - 13	24W-17231-00	16 - 14	36X-2172A-00	22 - 6	1T3-23145-00	26 - 4		
36X-11636-00	3 - 8	36X-14191-00	8 - 26	3GX-15431-00	12 - 15	36X-17241-01	16 - 15	3GX-2173E-10	22 - 9		26 - 23		
36X-11638-00	3 - 8	21V-14196-00	8 - 30	36X-15431-01	11 - 15	36X-17251-00	16 - 13	3GX-2173E-30	22 - 9	3DM-23149-10	26 - 15		
15A-11651-00	3 - 6	36X-14197-00	8 - 25	36X-15441-00	2 - 10	15A-17402-01	16 - 11	3GX-2173F-10	22 - 10		26 - 34		
5H0-11681-00	3 - 4	3G2-14231-25	8 - 3	15A-15451-02	11 - 2	36X-17411-00	16 - 1	3GX-2173F-30	22 - 10	4A1-23156-00	26 - 3		
5H0-12111-02	4 - 1	620-14231-74	8 - 16	4BE-15451-03	12 - 2	5H0-17456-00	16 - 26	3M7-21746-00	22 - 4		26 - 22		
4G0-12113-01	4 - 4	36X-14401-00	7 - 7	4BE-15462-00	11 - 16	1RL-18110-00	18 - 8	36X-2177F-00	22 - 11	509-23158-L0	26 - 9		
4G0-12114-01	4 - 5	3GX-14401-00	7 - 7		12 - 16	36X-18111-00	18 - 10	36X-22110-00-35	23 - 1		26 - 28		
4G0-12116-01	4 - 3	36X-14412-00	7 - 9	2HT-15512-00	14 - 21	132-18113-01	18 - 9	15A-22123-00	23 - 2	1U6-23168-M0	26 - 19		
4G0-12117-00	4 - 7	36X-14437-00	7 - 13	5H0-15517-00	14 - 24		18 - 11	36X-22126-00	23 - 6		26 - 38		
4G0-12118-00	4 - 8	36X-14451-00	7 - 10	5H0-15521-00	14 - 23	5H0-18120-02	18 - 1	36X-22126-10	23 - 7	36X-23170-00	26 - 8		
5H0-12119-00	4 - 6	36X-14452-00	7 - 12	4H7-15580-10	14 - 26	4G0-18140-00	17 - 8	401-22127-00	23 - 13		26 - 27		
5H0-12121-01	4 - 2	36X-14453-01	7 - 8	1J7-15583-01	14 - 28	5H0-18185-01	17 - 4	1W1-22128-00	24 - 8	1W1-23173-L0	26 - 7		
5H0-12146-00	4 - 11	36X-14458-00	7 - 11	36X-1561A-00	13 - 21	4JG-18511-00	17 - 11	401-22128-01	23 - 8		26 - 26		
36X-12151-00	4 - 9	36X-14468-00	7 - 14	36X-1561G-00	13 - 27	4JG-18512-01	17 - 12	3GX-22141-00	23 - 10	3YF-23181-00	26 - 42		
5H0-12156-00	4 - 10	3GX-14611-00	9 - 1	36X-15620-01	13 - 15	36X-18513-00	17 - 10	36X-22151-00	23 - 39	278-23181-50	26 - 10		
2NX-12159-00	4 - 13	36X-14611-01	9 - 1		14 - 15	3GX-18531-00	17 - 13	36X-22189-00	23 - 37		26 - 29		
36X-12171-00	5 - 1	5H0-14612-01	9 - 2	36X-15621-02	13 - 16	3GX-18535-00	17 - 14	36X-22210-20	24 - 1	36X-23191-10	26 - 11		

NUMERICAL INDEX
INDICE NUMERICO

PART NO. CODIGO N°	REF. NO.	PART NO. CODIGO N°	REF. NO.	PART NO. CODIGO N°	REF. NO.	PART NO. CODIGO N°	REF. NO.	PART NO. CODIGO N°	REF. NO.	PART NO. CODIGO N°	REF. NO.
36X-23191-10	26 - 30	36X-24860-10-35	29 - 10	15A-25454-11	32 - 18	3GX-81410-00	37 - 1	1KH-83311-00	40 - 20	355-83524-00	41 - 7
36X-23192-00	26 - 12	36X-24861-00	29 - 12	36X-26111-01	33 - 1	36X-81410-M0	36 - 2		40 - 29	355-83526-00	41 - 6
	26 - 31	36X-24862-00	29 - 11	36X-26111-11	33 - 1	50M-81801-M0	38 - 2	185-83311-10	39 - 4	36X-83550-00	41 - 9
4V2-23194-L0	26 - 13	3V6-25104-00	30 - 23		34 - 1	59V-81828-M0	38 - 4		39 - 12	47J-83550-00	41 - 9
	26 - 32	2A6-25104-01	31 - 23	36X-26123-01	33 - 15	4JG-8183G-00	38 - 6		39 - 20	4GY-83912-00	46 - 2
3R9-23318-00	25 - 15	248-25111-00-35	30 - 1	36X-26123-11	33 - 15	4JG-81890-00	38 - 1		39 - 25		47 - 2
3Y1-23319-00	25 - 13	2A6-25111-00-35	31 - 1		34 - 19	59V-81920-00	49 - 30	2T4-83312-00	40 - 3	23X-83922-00	46 - 13
36X-2331E-00	25 - 2	2K5-25118-00	30 - 30	3V6-26241-00	33 - 5	4FU-81940-01	49 - 25		40 - 12		47 - 9
36X-23340-01	26 - 39		31 - 31		34 - 2	59V-81942-00	49 - 31		40 - 21	3TB-83936-00	48 - 27
36X-23389-00	25 - 1	23F-25121-00-35	30 - 6	3V6-26242-00	33 - 2	1RL-81950-92	49 - 24		40 - 30	437-83936-01	46 - 24
3FR4-23389-00	26 - 43	3TL-25121-00-35	31 - 6		34 - 3	3TJ-81960-02	49 - 4	36X-83312-00	39 - 2		47 - 21
156-23411-00	26 - 40	36X-25135-00	30 - 9	3GX-26243-00	34 - 4	18A-81960-70	48 - 21		39 - 10	437-83936-11	48 - 26
22F-23411-01	25 - 7	5J0-25135-00	31 - 11	434-26243-00	33 - 3	4TP-82100-10	49 - 1		39 - 18	5Y1-83941-00	46 - 7
156-23412-00	25 - 5	109-25136-00	30 - 10	1M1-26249-01	33 - 4	558-82110-12	48 - 1		39 - 23	5Y1-83942-00	46 - 8
22F-23412-01	25 - 8		31 - 12		34 - 5	3GX-82115-00	49 - 28	36X-83318-00	39 - 6	36X-83965-00	46 - 11
36X-23416-00	25 - 10	102-25137-00	30 - 34	38V-26281-00-98	34 - 6	3GX-82116-00	49 - 29	3GX-83318-00	40 - 8		47 - 8
156-2341E-00	25 - 6		31 - 35	493-26282-00-98	34 - 7	4FU-82122-00	48 - 6	1KH-83320-10	40 - 10	36X-83972-01	46 - 19
22F-2341E-00	25 - 9	36X-25138-00	30 - 11	38V-2628H-00	34 - 8	3GX-82124-00	7 - 19	3XP-83320-10	40 - 28	3GX-83972-10	47 - 16
36X-23435-00	25 - 19	5J0-25138-00	31 - 13	1Y1-26290-50	33 - 13	36X-82131-00	48 - 2	36X-83320-20	39 - 9	4DW-83975-11	47 - 19
1E6-23441-10-98	25 - 22	183-25149-00	30 - 15		34 - 17	3GX-82131-00	7 - 18	1KH-83321-00	40 - 5	18G-83976-00	46 - 22
164-23462-00	26 - 41		31 - 17	1Y1-26290-60	33 - 14	55K-82150-01	48 - 4		40 - 14	3AB-83980-00	47 - 15
36X-24110-10-02	27 - 1	2N4-25155-00	31 - 19		34 - 18		49 - 2		40 - 23	3M7-84110-00	42 - 1
4H7-24181-00	27 - 3	558-25155-00	30 - 17	36X-26311-01	33 - 6	116-82151-00	48 - 5		40 - 32	3GX-84112-00	43 - 6
	28 - 3	3V6-25304-00	32 - 23	36X-26311-11	34 - 11		49 - 3	36X-83321-00	39 - 5	317-84112-30	42 - 5
36X-24182-00	27 - 4	391-25311-00-35	32 - 1	36X-26331-00	33 - 11	2GH-82151-00	49 - 26		39 - 13	248-84114-00	42 - 4
	28 - 4	109-25315-00	30 - 4	36X-26331-10	34 - 15	4JG-82310-00	49 - 14		39 - 21	276-84120-00	42 - 3
36X-24186-00	27 - 5		31 - 5	1RH-26335-00	33 - 8	3KJ-82310-10	48 - 7		39 - 26	4F2-84120-00	43 - 3
	28 - 5	183-25315-00	32 - 3		34 - 12	3NS-82370-00	49 - 16	36X-83328-00	39 - 14	3M7-84130-00	42 - 7
3GX-24240-10	27 - 2	248-25321-00-35	32 - 8	5Y1-26339-00	33 - 12	55X-82370-00	48 - 10	3GX-83328-00	40 - 17	3J0-84130-60	43 - 8
3GX-24240-30	28 - 2	36X-25327-00	32 - 22	36X-26341-01	33 - 10	3GX-82509-00	49 - 36	36X-83330-20	39 - 17	1M1-84133-60	43 - 2
3GX-24240-40	27 - 2	23F-2533A-00	30 - 22	36X-26341-11	34 - 14	36X-82510-02	48 - 23	36X-83340-20	39 - 22	1M1-84137-60	43 - 7
23F-24500-11	27 - 7	5T9-2533A-00	32 - 14	1E6-26342-00	33 - 9		49 - 19	1KH-83345-00	40 - 4	3J0-84195-60	43 - 1
	28 - 7	3Y6-2533A-01	31 - 8		34 - 13	2F1-82530-02	48 - 14		40 - 13	1A0-84314-01	43 - 5
4X8-24512-00	27 - 8	3Y6-25351-00	30 - 20	1E6-26372-00	33 - 20		49 - 8		40 - 22	202-84315-00	42 - 2
	28 - 8	248-25351-10	31 - 22		34 - 24	4KM-82540-00	48 - 12		40 - 31	148-84324-00	43 - 4
3AC-24523-00	27 - 10		32 - 11	36X-26372-00	33 - 17		49 - 17	4GY-83350-00	49 - 7	195-84324-00	42 - 6
	28 - 10	4V8-25355-00	32 - 12		34 - 21	3GX-82590-10	49 - 9	36X-83350-10	48 - 11	36X-84510-00	44 - 1
3AJ-24534-01	27 - 11	36X-25364-00	32 - 7	4BE-2637G-00	34 - 16	36X-82590-20	48 - 15	4GY-83368-00	40 - 26	122-84514-30	44 - 4
	28 - 11	31G-25366-00	32 - 15	36X-27211-00-90	35 - 1	3Y6-82911-00	47 - 1		40 - 35	1FE-84521-00	45 - 3
36X-24610-00	27 - 16	3V6-25371-00	32 - 31	36X-27231-00	35 - 4	5Y1-82911-01	46 - 1	36X-83371-11	48 - 16	1Y1-84521-00	44 - 2
	28 - 16	2K6-25381-10	32 - 40	36X-27311-01	35 - 22	3MW-82911-00	47 - 7	3TY-83371-11	49 - 10	36X-84527-00	44 - 5
3GX-24710-31	29 - 1	353-25381-10	30 - 28	36X-27311-11	35 - 23	1JN-82921-00	47 - 10	3GX-83510-00	41 - 1		45 - 6
3GX-24711-31	29 - 2		31 - 29	36X-27410-00-90	35 - 12	361-82921-31	46 - 14	3HA-83510-00	41 - 1	1KH-84710-00	45 - 1
36X-24810-00-35	29 - 4	36X-25386-00	32 - 37	36X-27420-00-90	35 - 16	1KH-83310-10	40 - 1	1M3-83513-00	41 - 5	34X-84714-00	45 - 2
36X-24810-00-98	29 - 4	36X-25387-00	32 - 38	36X-28100-00	29 - 13	3XP-83310-10	40 - 19	4N0-83516-00	41 - 3	1KH-84723-00	45 - 5
36X-24810-10-35	29 - 4	3V6-25388-00	32 - 43	36X-2811G-00	29 - 9	36X-83310-20	39 - 1	1YT-83517-00	41 - 3	12V-85540-10	48 - 18
36X-24860-00-35	29 - 10	3V6-25389-00	32 - 44	5PS-28217-00	19 - 19	1KH-83311-00	40 - 2	2W0-83520-00	41 - 2	3GX-85540-10	49 - 12
36X-24860-00-98	29 - 10	1T2-25394-00	32 - 28	8U9-77162-00	49 - 5		40 - 11	3GX-83520-00	41 - 2	3GX-85546-00	49 - 13

NUMERICAL INDEX
INDICE NUMERICO

PART NO. CODIGO N°	REF. NO.	PART NO. CODIGO N°	REF. NO.	PART NO. CODIGO N°	REF. NO.	PART NO. CODIGO N°	REF. NO.	PART NO. CODIGO N°	REF. NO.	PART NO. CODIGO N°	REF. NO.
5MP-85550-00	37 - 2	90152-06010	13 - 19	90201-08366	20 - 9	90338-09130	31 - 28	90467-09006	27 - 15	91317-06025	37 - 4
36X-85550-M0	36 - 1		14 - 19		20 - 13	90340-14068	11 - 6		28 - 15	91317-06030	2 - 6
4JG-85580-01	37 - 3	90153-06029	1 - 4	90201-08609	1 - 10		12 - 6	90467-10035	7 - 2	91317-08020	14 - 30
15A-85580-M0	36 - 3	90153-06042	46 - 9		1 - 10	90340-32116	11 - 8	90467-10039	7 - 2	91317-08025	9 - 16
3FA-W253A-00	32 - 9	90157-05027	46 - 23	90201-10126	24 - 6		12 - 8	90467-14015	10 - 12	91317-08045	1 - 11
3KG-W253E-00	31 - 9	90159-05011	15 - 12	90201-10135	13 - 25	90380-12051	24 - 3	90468-06134	23 - 38	91401-20012	32 - 36
4BE-W253E-00	30 - 7		40 - 7	90201-10508	3 - 29	90386-14103	15 - 28	90468-26122	13 - 2		35 - 7
36X-Y2410-10-01	28 - 1		40 - 16	90201-10591	5 - 5	90386-18028	23 - 3		14 - 2	91401-25015	35 - 15
36X-Y2410-10-02	27 - 1		40 - 25	90201-10644	13 - 23	90387-051K7	7 - 16	90480-01141	22 - 5		35 - 19
90101-06278	30 - 18		40 - 34	90201-120A5	23 - 12	90387-05285	40 - 6	90480-01558	22 - 5	91401-25020	24 - 11
	31 - 20	90159-06085	21 - 6	90201-12588	5 - 18		40 - 15	90480-12320	22 - 3	91701-08038	35 - 14
90101-06291	32 - 13	90170-06128	4 - 14		18 - 5		40 - 24	90480-14229	19 - 21		35 - 18
90101-10188	3 - 30	90170-08258	32 - 21	90201-12749	30 - 32		40 - 33		20 - 21	92902-04100	8 - 29
90101-10303	5 - 4	90170-10038	33 - 7		31 - 33	90387-05563	44 - 6	90501-04596	14 - 27	92907-05100	36 - 5
90105-065A1	6 - 16	90170-14284	3 - 27	90201-17257	16 - 19		45 - 7	90501-07629	3 - 19		36 - 7
90105-08066	19 - 11		15 - 4	90201-173F4	13 - 11	90387-061M0	23 - 36	90501-10245	35 - 9		38 - 8
	20 - 11		15 - 21		14 - 11	90387-062V8	21 - 2	90501-12081	13 - 17	92907-05600	7 - 21
90105-08141	9 - 20	90170-20224	32 - 39	90201-175F6	13 - 7	90387-06681	23 - 32		14 - 17		25 - 17
	29 - 6	90175-06013	35 - 11		14 - 7	90387-067V1	41 - 4	90501-12792	30 - 36		44 - 9
90105-08195	1 - 9	90176-08068	43 - 10	90201-201E4	3 - 12	90387-12265	30 - 29		31 - 37		45 - 10
90105-10058	35 - 21	90179-05271	49 - 32	90201-20269	30 - 14		31 - 30	90501-18576	6 - 7		48 - 25
90105-14102	25 - 12	90179-06524	19 - 20		31 - 16	90387-125F1	10 - 4	90501-21133	3 - 14		49 - 21
90109-06418	5 - 19	90179-08148	33 - 19	90201-203E7	16 - 21		10 - 5	90501-23700	15 - 11	92907-06100	46 - 6
90109-06419	6 - 13		33 - 22	90201-25290	14 - 25	90387-125Y0	14 - 22	90506-08227	18 - 2		46 - 16
90109-06799	46 - 3		34 - 23	90202-05193	27 - 13	90387-155J5	32 - 42	90506-14343	35 - 8		47 - 6
	46 - 17		34 - 26		28 - 13	90387-255F3	5 - 6	90506-15260	30 - 8		47 - 12
	47 - 3	90179-25033	25 - 11	90206-06090	9 - 6	90430-06014	1 - 5		31 - 10		48 - 20
	47 - 13	90185-08089	19 - 6		9 - 11		5 - 20		32 - 10	92907-06200	15 - 16
90109-08063	32 - 32		19 - 10	90209-10131	46 - 10		10 - 10	90506-28100	35 - 24		35 - 6
90109-08368	32 - 33		19 - 14	90209-16209	16 - 3	90430-08119	15 - 23	90508-14620	13 - 26		46 - 12
90109-10473	35 - 25		20 - 6	90209-17226	13 - 9	90430-10148	48 - 13	90508-16428	5 - 16	92907-06600	5 - 14
90109-10554	24 - 5		20 - 10		14 - 9		49 - 18	90508-18537	15 - 25		9 - 14
90110-06064	1 - 19		20 - 14	90209-18208	16 - 16	90430-14131	1 - 8	90508-20023	35 - 13		13 - 28
90116-08425	32 - 19	90185-10037	35 - 26	90214-17028	13 - 13	90445-070K7	49 - 33		35 - 17		22 - 8
90119-06063	21 - 3	90185-10091	25 - 21		14 - 13	90445-08171	48 - 3	90508-26538	13 - 5		23 - 16
	21 - 14	90185-12134	23 - 11	90214-20023	3 - 17	90445-10638	27 - 14		14 - 5		23 - 19
	29 - 3	90201-05032	23 - 35	90215-06184	1 - 22		28 - 14	90508-26539	17 - 9		25 - 4
90119-06074	23 - 22	90201-054K4	44 - 7	90215-08160	32 - 20	90460-56105	7 - 22	90508-29540	18 - 3		39 - 8
90119-06097	21 - 10		45 - 8	90215-14186	15 - 20	90462-08224	10 - 14	90560-12138	30 - 3		39 - 16
90122-06012	7 - 15	90201-06557	21 - 8	90215-14205	3 - 26	90462-08225	10 - 15		31 - 3		48 - 9
90123-08046	33 - 18	90201-07076	30 - 13		15 - 3	90462-16213	12 - 12	90560-15136	32 - 2	92907-08100	32 - 34
	33 - 21		31 - 15	90240-06076	35 - 5	90464-13249	21 - 15	91317-06010	12 - 11		42 - 10
	34 - 22	90201-08326	9 - 21	90240-07083	3 - 18	90464-23041	47 - 18	91317-06018	1 - 18	92907-08600	9 - 17
	34 - 25		29 - 7	90240-12092	24 - 9	90465-08020	10 - 13		1 - 18		42 - 11
90149-06011	27 - 12	90201-08366	19 - 5	90249-12008	35 - 10	90465-08188	11 - 10	91317-06020	7 - 5	92907-10200	30 - 33
	28 - 12		19 - 9	90280-05013	3 - 28	90465-08364	12 - 10		9 - 19		31 - 34
90149-08067	15 - 24		19 - 13	90282-05013	3 - 25	90465-13152	49 - 23		37 - 5	92907-12600	24 - 10
90151-06013	17 - 7		20 - 5	90282-05043	15 - 2	90465-16187	11 - 12	91317-06025	5 - 12	92990-05600	49 - 35

NUMERICAL INDEX
INDICE NUMERICO

PART NO. CODIGO N°	REF. NO.	PART NO. CODIGO N°	REF. NO.	PART NO. CODIGO N°	REF. NO.	PART NO. CODIGO N°	REF. NO.	PART NO. CODIGO N°	REF. NO.	PART NO. CODIGO N°	REF. NO.
93101-15101	16 - 9	93306-30611	3 - 7	95027-06025	12 - 18	95807-08016	34 - 20	98507-05012	48 - 24		
93102-10207	13 - 24	93310-530J3	3 - 5	95027-06030	10 - 6	95807-08030	43 - 9		49 - 20		
93102-12106	18 - 7	93315-23607	17 - 3	95027-06035	11 - 5	95817-08012	29 - 5	98507-05016	7 - 20		
93102-12321	5 - 17	93410-20038	16 - 4		11 - 19	95817-08050	19 - 8		25 - 16		
93102-14209	15 - 29	93410-22039	16 - 17		12 - 5		20 - 8		34 - 10		
93102-17263	13 - 10	93420-28055	15 - 30		12 - 19	95817-08065	19 - 3	98507-05018	47 - 20		
	14 - 10	93440-10085	1 - 3	95027-06040	10 - 7		20 - 3	98507-05025	36 - 6		
93102-18008	30 - 5	93450-17044	3 - 11	95027-06045	11 - 20	95817-08070	19 - 4	98507-05030	36 - 4		
	31 - 4	93505-16006	15 - 27		12 - 20		20 - 4		47 - 17		
93102-20004	16 - 23	93507-32009	13 - 18	95027-06080	10 - 8	95827-08035	25 - 23	98507-06010	9 - 13		
93102-47297	30 - 21		14 - 18	95027-06085	10 - 9	95827-08090	23 - 30		11 - 11		
93104-07003	30 - 12	93602-13177	3 - 20	95027-06090	10 - 8	95827-08120	19 - 12	98507-06012	22 - 7		
	31 - 14	93603-12030	6 - 3	95307-05600	25 - 18		20 - 12		25 - 3		
93104-22018	32 - 5	93604-10011	5 - 3	95307-06600	15 - 17	95827-10060	25 - 20	98507-06016	23 - 18		
93105-47007	31 - 7	93604-16092	17 - 5		30 - 19	95827-12025	35 - 20		39 - 7		
93106-26005	32 - 17	93604-20156	17 - 6		31 - 21	97007-05020	44 - 8		39 - 15		
93109-18020	23 - 9	93605-10090	3 - 15		41 - 8		45 - 9	98507-06020	36 - 8		
93210-07135	6 - 14	93608-50158	18 - 6	95307-06700	21 - 7	97007-06012	1 - 21	98507-06025	49 - 6		
93210-09165	4 - 12	93615-12088	14 - 29		35 - 3	97007-06016	48 - 19	98507-06045	23 - 15		
93210-13361	2 - 4	93700-06004	23 - 4	95307-08700	32 - 35	97007-06020	35 - 2	98511-03045	44 - 3		
93210-14104	30 - 35	93700-06009	23 - 5	95317-06700	13 - 29		48 - 8		45 - 4		
	31 - 36	93822-14043	16 - 25	95607-06100	46 - 4	97007-06022	46 - 5	98707-04012	34 - 9		
93210-14369	11 - 7	94108-2111T	31 - 24		46 - 18		46 - 15	98707-06030	6 - 5		
	12 - 7	94130-195E9	30 - 24		47 - 4		47 - 5	98907-06010	9 - 5		
93210-19123	11 - 22	94141-185E8	32 - 24		47 - 14		47 - 11		9 - 10		
	12 - 22	94227-19292	30 - 25	95607-06200	23 - 17	97007-08025	42 - 9	99001-10600	18 - 4		
93210-25711	38 - 5	94227-21293	31 - 25	95607-10100	24 - 7	97027-06010	16 - 27	99009-10400	13 - 22		
93210-32172	11 - 9	94232-18113	32 - 25	95607-10200	30 - 31	97027-06016	5 - 13	99009-17400	13 - 6		
	12 - 9	94325-18081	32 - 26		31 - 32	97027-06020	18 - 12		13 - 14		
93210-347A1	6 - 9	94327-19111	30 - 26	95607-14200	32 - 41	97027-08030	13 - 20		14 - 6		
93210-35537	7 - 4	94330-21088	31 - 26	95707-08500	40 - 27		14 - 20		14 - 14		
93210-42101	32 - 6	94416-19002	30 - 27		40 - 36	97706-30108	39 - 3		16 - 20		
93210-48364	15 - 15	94416-21006	31 - 27		42 - 12		39 - 11	99009-20400	30 - 16		
93210-54175	6 - 12	94418-18008	32 - 27	95807-06008	20 - 18		39 - 19		31 - 18		
93210-55669	38 - 3	94580-41104	5 - 7		20 - 20		39 - 24	99530-12016	10 - 2		
93210-57634	1 - 17	94580-88122	32 - 29	95807-06010	40 - 9	97707-50512	23 - 34		11 - 3		
93210-72529	2 - 2	94680-88001	32 - 30		40 - 18	97802-04006	8 - 19		11 - 17		
93211-05471	1 - 13	94701-00157	1 - 23	95807-06012	19 - 18	97802-05008	8 - 24		12 - 3		
93306-00416	32 - 16	94701-00181	1 - 23		25 - 14	97880-05020	49 - 34		12 - 17		
93306-20201	16 - 10	95027-06008	49 - 27		48 - 17	98502-04014	8 - 28	99530-14016	1 - 7		
93306-20212	32 - 4	95027-06016	49 - 15		49 - 11	98506-05025	46 - 20		2 - 5		
93306-20332	16 - 24	95027-06020	1 - 14	95807-06016	7 - 23	98506-05030	46 - 21				
93306-20401	16 - 8	95027-06025	6 - 15		23 - 33	98507-03008	27 - 9				
93306-30101	31 - 2		11 - 4		27 - 6		28 - 9				
93306-30103	30 - 2		11 - 14		28 - 6	98507-04030	23 - 27				
93306-30424	16 - 22		11 - 18	95807-06025	48 - 22	98507-05008	23 - 25				
93306-30427	3 - 23		12 - 4	95807-08012	23 - 29		38 - 7				
	3 - 24		12 - 14	95807-08016	33 - 16	98507-05012	42 - 8				