



# PARTS CATALOGUE

**FZ6RY'09** (36P1) U49



1H36P-110E1

( )

FZ6RY/FZ6RYC  
PARTS CATALOGUE  
©2008 by Yamaha Motor Co., Ltd.  
1st edition, December 2008  
All rights reserved.  
Any reprinting or unauthorized use  
without the written permission of  
Yamaha Motor Co., Ltd.  
is expressly prohibited.  
Printed in Japan.

# FOREWORD

This Parts Catalogue is related to the parts for the model(s) on the cover page. When you are ordering replacement parts, please refer to this Parts Catalogue and quote both part numbers and part names correctly.

1. Modifications or additions which have been made after the issue of the Parts Catalogue will be announced in the Parts News.

It is advisable that you make the necessary corrections to the Parts Catalogue according to the Parts News.

2. Abbreviations

The following abbreviations are used in this Parts Catalogue.

“UR” Use specified parts number.

“UN” Use as many as needed.

“AP” Alternate Parts

“LM” Locally Made (Parts need to be ordered locally)

“F#” Frame No. (Applicable machine No.)

“O/S” Over Size

3. The number of components for assembly

- Parts, which are to be supplied in an assembly, are listed with a dot (.) in front of the part name as shown below.
- The numeral appearing to the right of each component part indicates the quantity of parts for each assembly unit.

PART NO.	DESCRIPTION	Q'TY	REMARKS
2F5-83310-60	FRONT FLASHER LIGHT ASSY	2	
115-83311-60	.BULB (6V-18W)	1	

4. Applicable colours of graphics are represented in the “REMARKS” as shown below.

PART NO.	DESCRIPTION	Q'TY	REMARKS
2N4-24110-00-X5	FUEL TANK COMP.	2	MXR
3J1-24240-10	.GRAPHIC, FUEL TANK	1	FOR MXR

5. Note that the illustrations for reference in finding parts numbers are not to be used for assembling. When assembling, please use the applicable service manual.

6. The asterisk (\*) before a reference number indicates modified items after the first edition.





# CONTENTS

## ENGINE

CYLINDER HEAD .....	1
CRANKSHAFT & PISTON .....	2
VALVE .....	3
CAMSHAFT & CHAIN .....	5
WATER PUMP .....	6
RADIATOR & HOSE .....	7
OIL PUMP .....	9
OIL CLEANER .....	10
INTAKE .....	11
INTAKE 2 .....	12
AIR INDUCTION SYSTEM .....	14
EXHAUST .....	15
CRANKCASE .....	16
CRANKCASE COVER 1 .....	17
STARTER .....	19
CLUTCH .....	20
TRANSMISSION .....	22
SHIFT CAM & FORK .....	24
SHIFT SHAFT .....	25

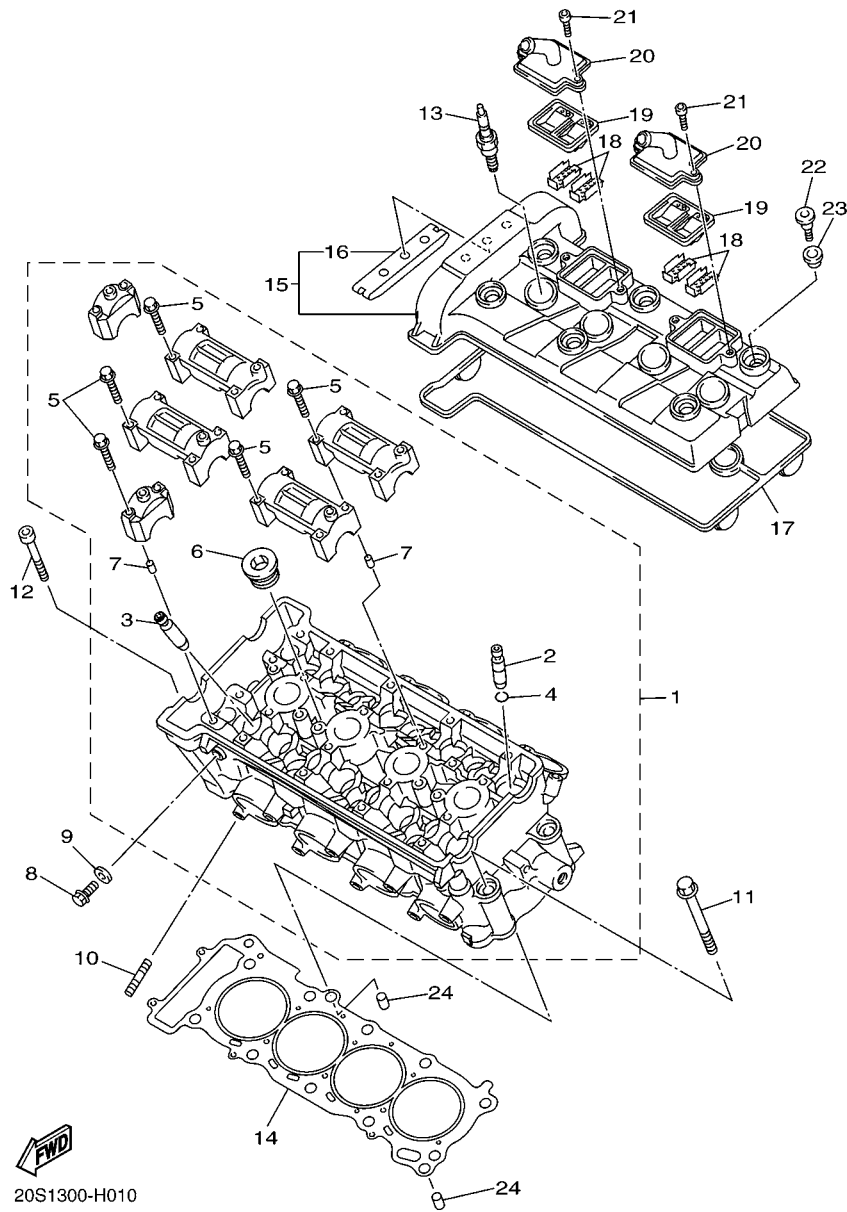
## CHASSIS

FRAME .....	27
FENDER .....	28
SIDE COVER .....	30
REAR ARM .....	32
REAR SUSPENSION .....	33
STEERING .....	34
FRONT FORK .....	35
FUEL TANK .....	37
SEAT .....	39
FRONT WHEEL .....	41
FRONT BRAKE CALIPER .....	42
REAR WHEEL .....	43
REAR BRAKE CALIPER .....	45
STEERING HANDLE & CABLE .....	46
FRONT MASTER CYLINDER .....	47
STAND & FOOTREST .....	48
REAR MASTER CYLINDER .....	51
COWLING 1 .....	53
COWLING 2 .....	55
GENERATOR .....	58

STARTING MOTOR .....	59
FLASHER LIGHT .....	60
METER .....	61
HEADLIGHT .....	62
TAILLIGHT .....	63
HANDLE SWITCH & LEVER .....	64
ELECTRICAL 1 .....	65
ELECTRICAL 2 .....	67

## INDEX

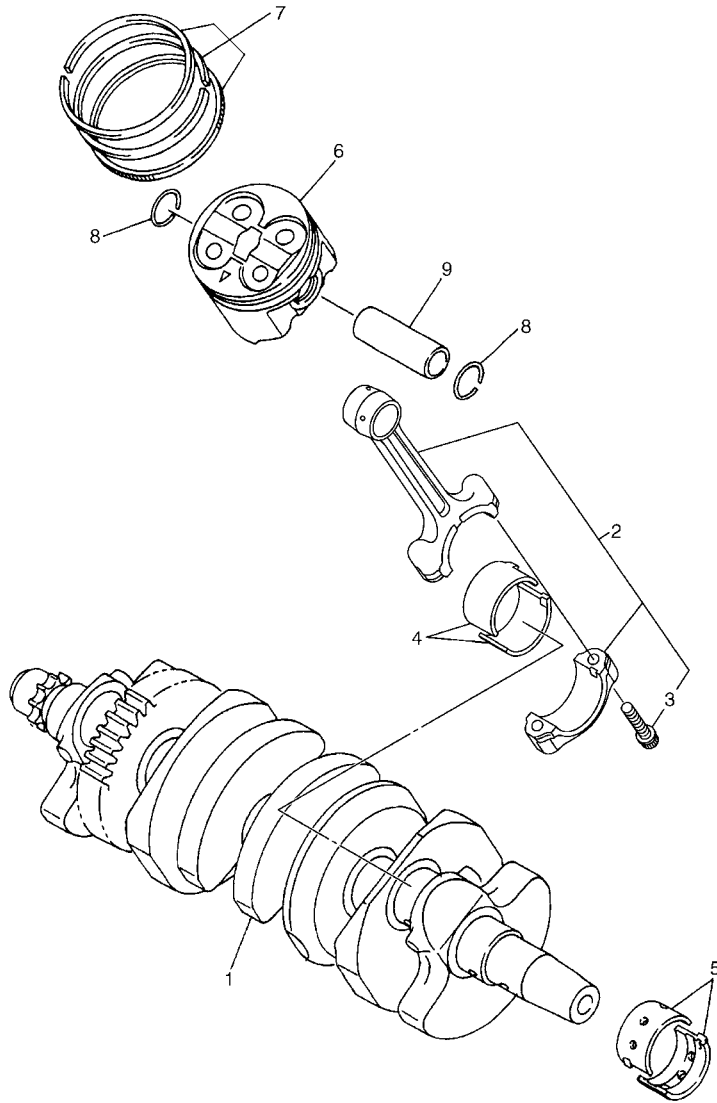
NUMERICAL INDEX .....	69
-----------------------	----



20S1300-H010

FIG. 1 CYLINDER HEAD

REF. NO.	PART NO.	DESCRIPTION	36P1	36P2		REMARKS
1	20S-11101-00	CYLINDER HEAD ASSY	1	1		
2	5EB-11133-10	.GUIDE, VALVE 1	8	8		
3	20S-11134-10	.GUIDE, VALVE 2	8	8		
4	93440-10153	.CIRCLIP	8	8		
5	90105-06027	.BOLT, FLANGE	20	20		
6	90340-20090	.PLUG, STRAIGHT SCREW	3	3		
7	91808-16023	.PIN, DOWEL	12	12		
8	95022-08012	BOLT, FLANGE	1	1		
9	90430-08119	GASKET	1	1		
10	95612-08625	BOLT, STUD	8	8		
11	90119-10003	BOLT, WITH WASHER	10	10		
12	91312-06060	BOLT	2	2		
13	94701-00318	PLUG, SPARK (NGK R CR9E)	4	4		
14	20S-11181-00	GASKET, CYLINDER HEAD 1	1	1		
15	1B3-11191-00	COVER, CYLINDER HEAD 1	1	1		
16	5BE-12241-00	.GUIDE, STOPPER 2	1	1		
17	20S-11193-00	GASKET, HEAD COVER 1	1	1		
18	5SL-1482K-00	PLATE	4	4		
19	5SL-14890-00	REED VALVE ASSY	2	2		
20	5SL-14899-00	CAP, CASE	2	2		
21	91312-06020	BOLT	4	4		
22	90109-066F0	BOLT	6	6		
23	5VY-1111G-00	RUBBER, MOUNT 1	6	6		
24	99530-10114	PIN, DOWEL	2	2		



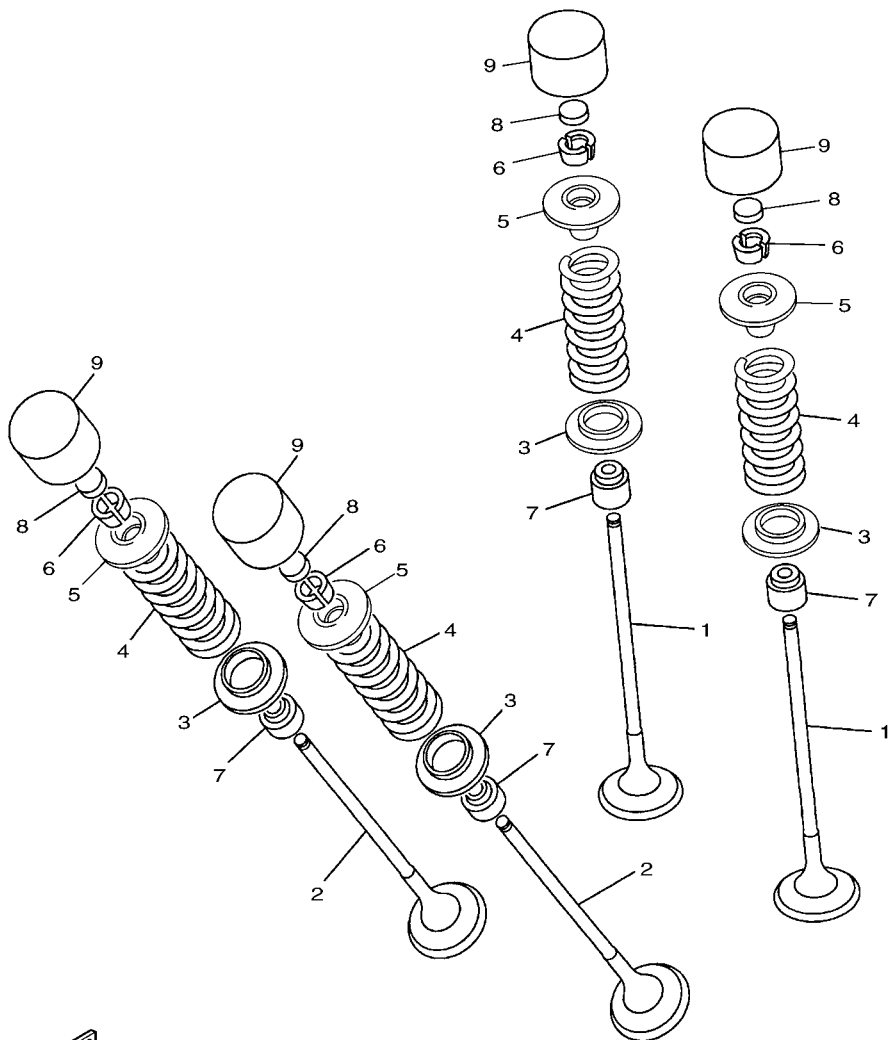
5S44300-H020

FIG. 2 CRANKSHAFT & PISTON

REF. NO.	PART NO.	DESCRIPTION	36P1	36P2	REMARKS
1	20S-11411-00	CRANKSHAFT	1	1	
2	5VX-11650-00	CONNECTING ROD ASSY	4	4	
3	5VX-11654-00	.BOLT, CONNECTING ROD	2	2	
4	5VX-11656-00	PLANE BEARING, CONNECTING ROD	8	8	UR BLUE
	5VX-11656-10	PLANE BEARING, CONNECTING ROD	8	8	UR BLACK
	5VX-11656-20	PLANE BEARING, CONNECTING ROD	8	8	UR BROWN
	5VX-11656-30	PLANE BEARING, CONNECTING ROD	8	8	UR GREEN
5	5EB-11416-A0	PLANE BEARING, CRANKSHAFT 1	10	10	UR WHITE
	5EB-11416-00	PLANE BEARING, CRANKSHAFT 1	10	10	UR BLUE
	5EB-11416-10	PLANE BEARING, CRANKSHAFT 1	10	10	UR BLACK
	5EB-11416-20	PLANE BEARING, CRANKSHAFT 1	10	10	UR BROWN
	5EB-11416-30	PLANE BEARING, CRANKSHAFT 1	10	10	UR GREEN
6	5SL-11631-00	PISTON (STD)	4	4	
7	20S-11603-00	PISTON RING SET (STD)	4	4	
8	93450-17129	CIRCLIP	8	8	
9	20S-11633-00	PIN, PISTON	4	4	

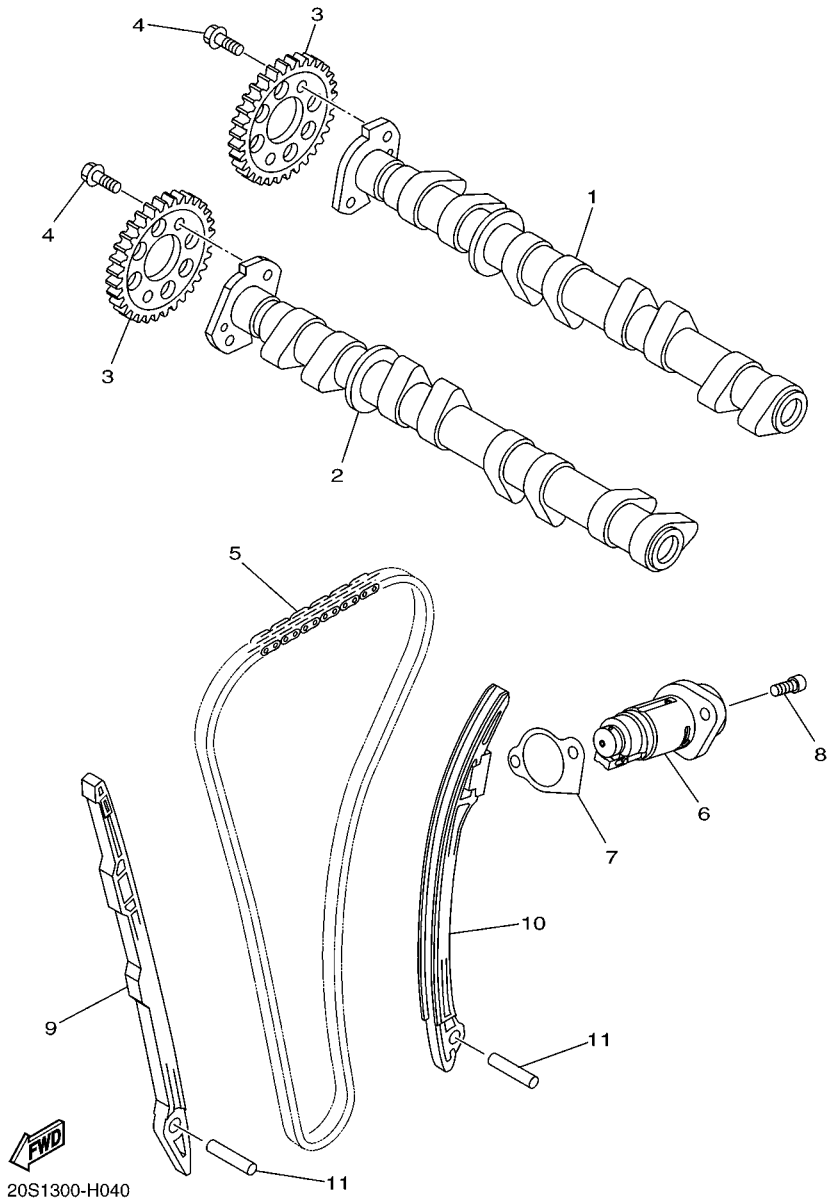
FIG. 3 VALVE

REF. NO.	PART NO.	DESCRIPTION	36P1	36P2			REMARKS
1	20S-12111-00	VALVE, INTAKE	8	8			
2	20S-12121-00	VALVE, EXHAUST	8	8			
3	5EB-12126-00	SEAT, VALVE SPRING 2	16	16			
4	20S-12113-00	SPRING, VALVE INNER	16	16			
5	5EB-12127-00	RETAINER, VALVE SPRING	16	16			
6	1HX-12118-00	COTTER, VALVE	32	32			
7	4TV-12119-00	SEAL, VALVE STEM	16	16			
8	1HX-12168-00	PAD, ADJUSTING 2 (1.20)	16	16			UR
	1HX-12168-20	PAD, ADJUSTING 2 (1.25)	16	16			UR
	1HX-12168-40	PAD, ADJUSTING 2 (1.30)	16	16			UR
	1HX-12168-60	PAD, ADJUSTING 2 (1.35)	16	16			UR
	1HX-12168-80	PAD, ADJUSTING 2 (1.40)	16	16			UR
	1HX-12168-A0	PAD, ADJUSTING 2 (1.45)	16	16			UR
	1HX-12168-F0	PAD, ADJUSTING 2 (1.50)	16	16			UR
	1HX-12168-H1	PAD, ADJUSTING 2 (1.55)	16	16			UR
	1HX-12168-K1	PAD, ADJUSTING 2 (1.60)	16	16			UR
	1HX-12168-M1	PAD, ADJUSTING 2 (1.65)	16	16			UR
	1HX-12168-R1	PAD, ADJUSTING 2 (1.70)	16	16			UR
	1HX-12168-U1	PAD, ADJUSTING 2 (1.75)	16	16			UR
	1HX-12168-W1	PAD, ADJUSTING 2 (1.80)	16	16			UR
	1HX-12168-Y1	PAD, ADJUSTING 2 (1.85)	16	16			UR
	1HX-12169-11	PAD, ADJUSTING 2 (1.90)	16	16			UR
	1HX-12169-31	PAD, ADJUSTING 2 (1.95)	16	16			UR
	1HX-12169-50	PAD, ADJUSTING 2 (2.00)	16	16			UR
	1HX-12169-70	PAD, ADJUSTING 2 (2.05)	16	16			UR
	1HX-12169-90	PAD, ADJUSTING 2 (2.10)	16	16			UR
	1HX-12169-E0	PAD, ADJUSTING 2 (2.15)	16	16			UR



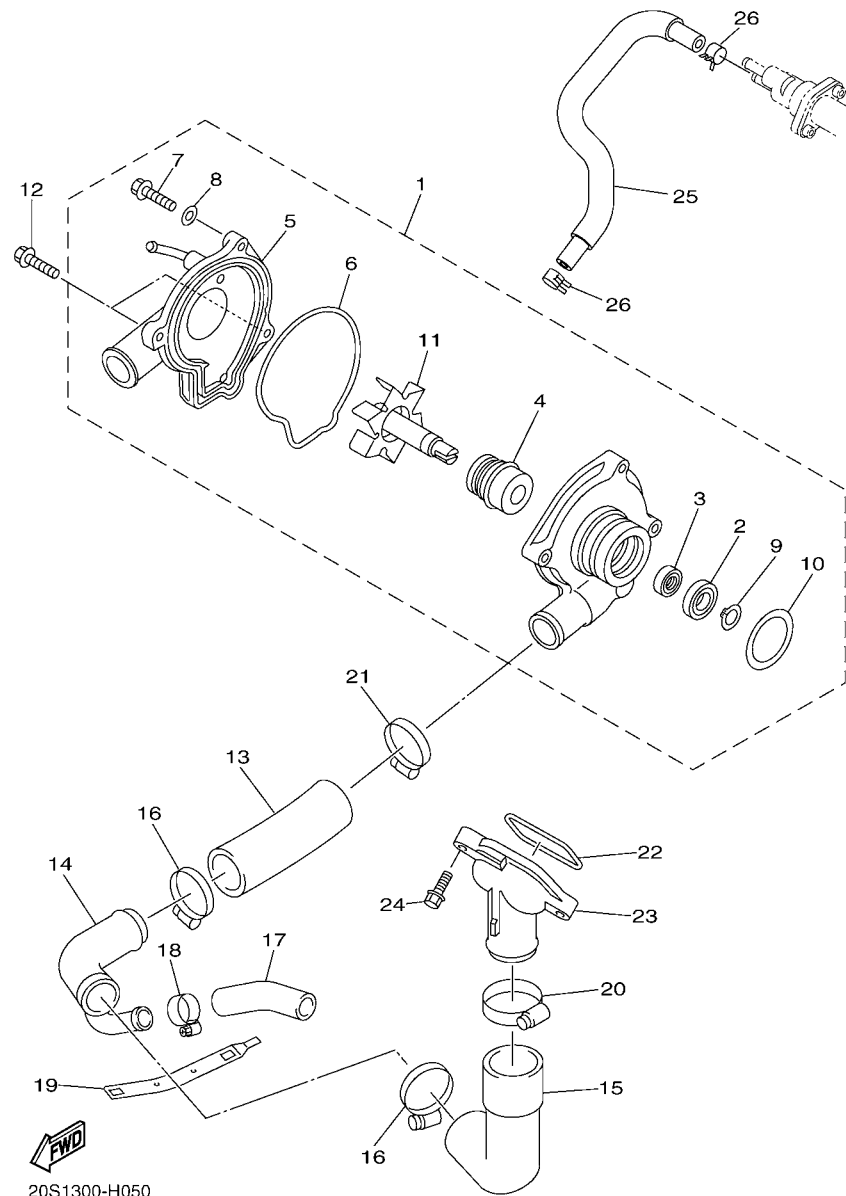
20S1300-H030





**FIG. 4 CAMSHAFT & CHAIN**

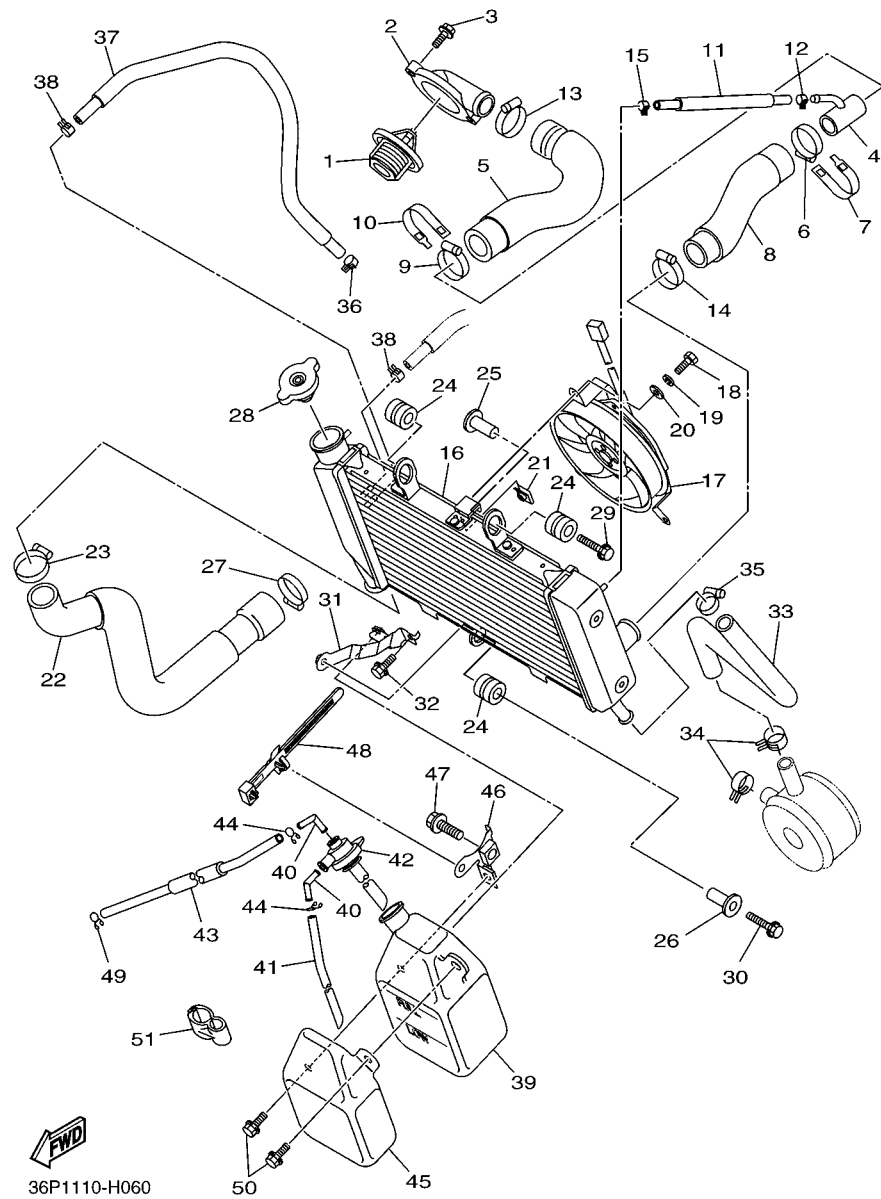
REF. NO.	PART NO.	DESCRIPTION	36P1	36P2				REMARKS
1	20S-12170-00	CAMSHAFT ASSY 1	1	1				
2	20S-12180-00	CAMSHAFT ASSY 2	1	1				
3	20S-12176-00	SPROCKET, CAM CHAIN	2	2				
4	90105-07004	BOLT, FLANGE	4	4				
5	94591-68120	CHAIN	1	1				
6	20S-12210-00	TENSIONER ASSY, CAM CHAIN	1	1				
7	2C0-12213-00	GASKET, TENSIONER CASE	1	1				
8	90110-06335	BOLT, HEXAGON SOCKET HEAD	2	2				
9	2C0-12251-00	DAMPER, CHAIN 1	1	1				
10	13S-12252-00	DAMPER, CHAIN 2	1	1				
11	93607-44002	PIN, DOWEL	2	2				



20S1300-H050

FIG. 5 WATER PUMP

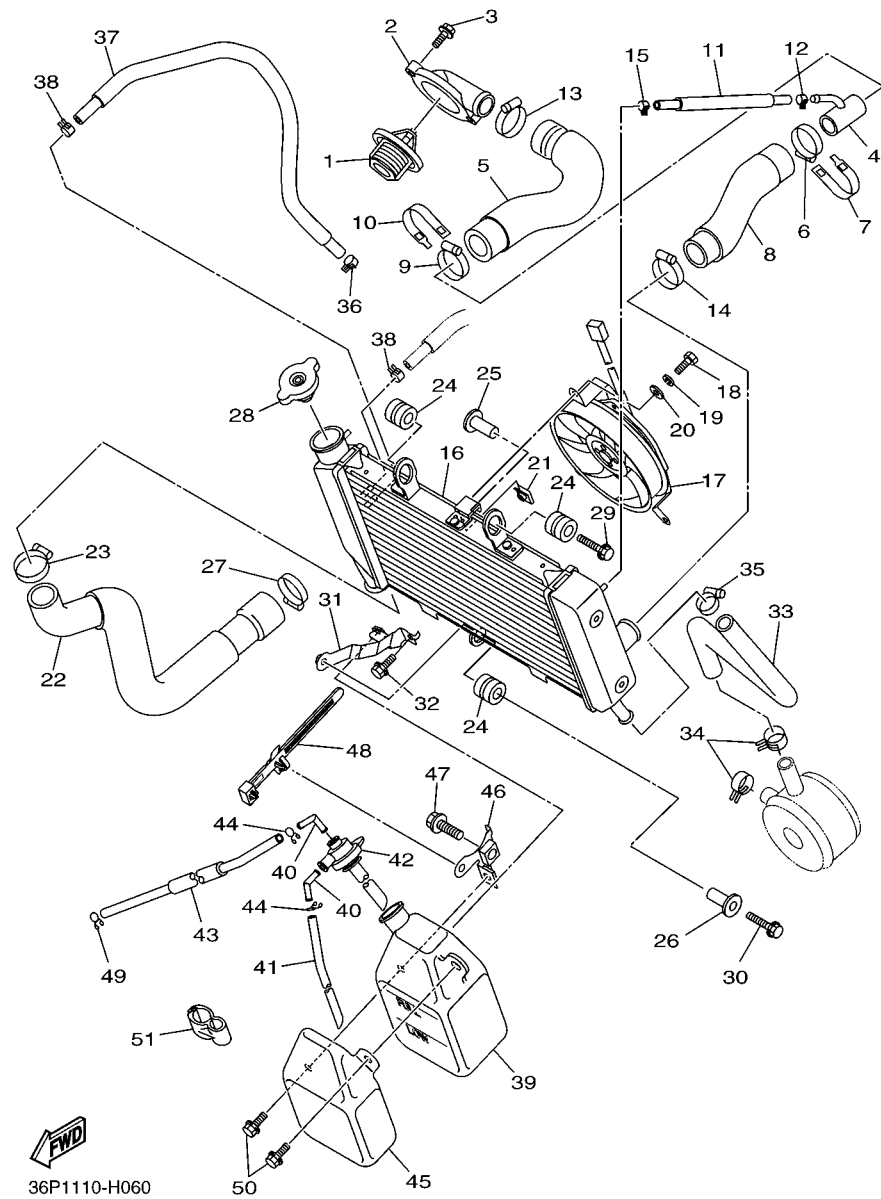
REF. NO.	PART NO.	DESCRIPTION	36P1	36P2	REMARKS
1	20S-12420-00	WATER PUMP ASSY	1	1	
2	93306-00106	.BEARING	1	1	
3	93101-12173	.OIL SEAL	1	1	
4	4C8-12438-00	.SEAL, MECHANICAL	1	1	
5	5SL-12422-00	.COVER, HOUSING	1	1	
6	5EB-12439-00	.O-RING	1	1	
7	95024-06020	.BOLT, FLANGE	2	2	
8	90430-06014	.GASKET	1	1	
9	99009-12400	.CIRCLIP	1	1	
10	93210-33133	.O-RING	1	1	
11	20S-12450-00	.IMPELLER SHAFT ASSY	1	1	
12	90110-06086	BOLT, HEXAGON SOCKET HEAD	2	2	
13	4NK-12579-00	HOSE 4	1	1	
14	20S-12581-00	JOINT, HOSE 1	1	1	
15	5EB-12577-01	HOSE 2	1	1	
16	90450-35001	HOSE CLAMP ASSY	2	2	
17	5SL-12588-01	HOSE 5	1	1	
18	90450-22017	HOSE CLAMP ASSY	1	1	
19	5GV-1246E-00	COVER 2	1	1	
20	90450-38003	HOSE CLAMP ASSY	1	1	
21	90450-32006	HOSE CLAMP ASSY	1	1	
22	93210-46001	O-RING	1	1	
23	5EB-12469-00	JOINT 1	1	1	
24	90105-06053	BOLT, FLANGE	2	2	
25	5VX-1243A-00	HOSE 1	1	1	
26	90467-110A2	CLIP	2	2	



36P1110-H060

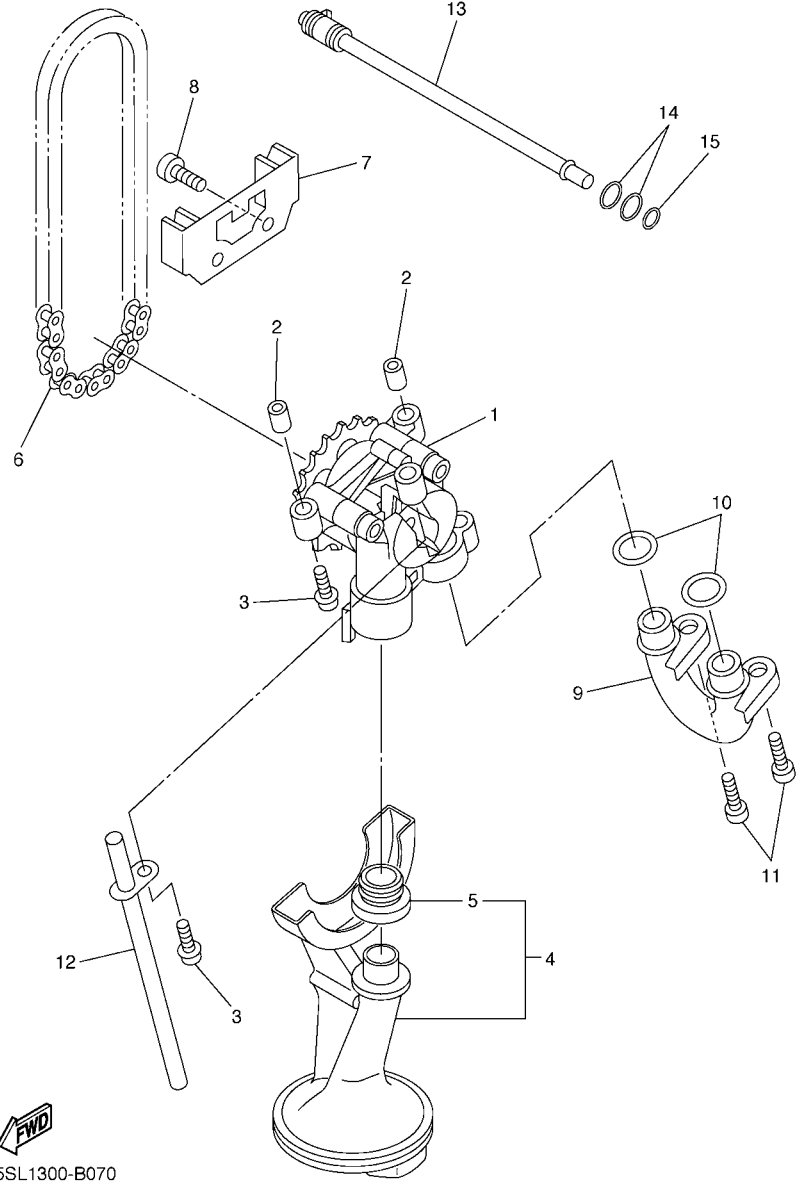
FIG. 6 RADIATOR & HOSE

REF. NO.	PART NO.	DESCRIPTION	36P1	36P2	REMARKS
1	5SL-12410-00	THERMOSTAT ASSY	1	1	
2	5VX-12413-00	COVER, THERMOSTAT	1	1	
3	90105-06164	BOLT, FLANGE	2	2	
4	20S-12582-00	JOINT, HOSE 2	1	1	
5	20S-12578-00	HOSE 3	1	1	
6	90450-32003	HOSE CLAMP ASSY	1	1	
7	20S-1246E-00	COVER 2	1	1	
8	20S-12551-00	HOSE 7	1	1	
9	90450-32003	HOSE CLAMP ASSY	1	1	
10	20S-1246E-00	COVER 2	1	1	
11	90445-12012	HOSE	1	1	
12	90467-11090	CLIP	1	1	
13	90450-32006	HOSE CLAMP ASSY	1	1	
14	90450-32003	HOSE CLAMP ASSY	1	1	
15	90467-11090	CLIP	1	1	
16	20S-12461-01	RADIATOR ASSY	1	1	
17	20S-12405-00	BLOWER ASSY	1	1	
18	97307-06012	BOLT	3	3	
19	92907-06100	WASHER, SPRING	3	3	
20	92907-06600	WASHER, PLATE	3	3	
21	1AA-12535-00	PLATE	3	3	
22	20S-12579-00	HOSE 4	1	1	
23	90450-32003	HOSE CLAMP ASSY	1	1	
24	90480-15363	GROMMET	3	3	
25	90387-0614M	COLLAR	1	1	
26	90387-0614M	COLLAR	1	1	
27	90450-32006	HOSE CLAMP ASSY	1	1	



**FIG. 6 RADIATOR & HOSE**

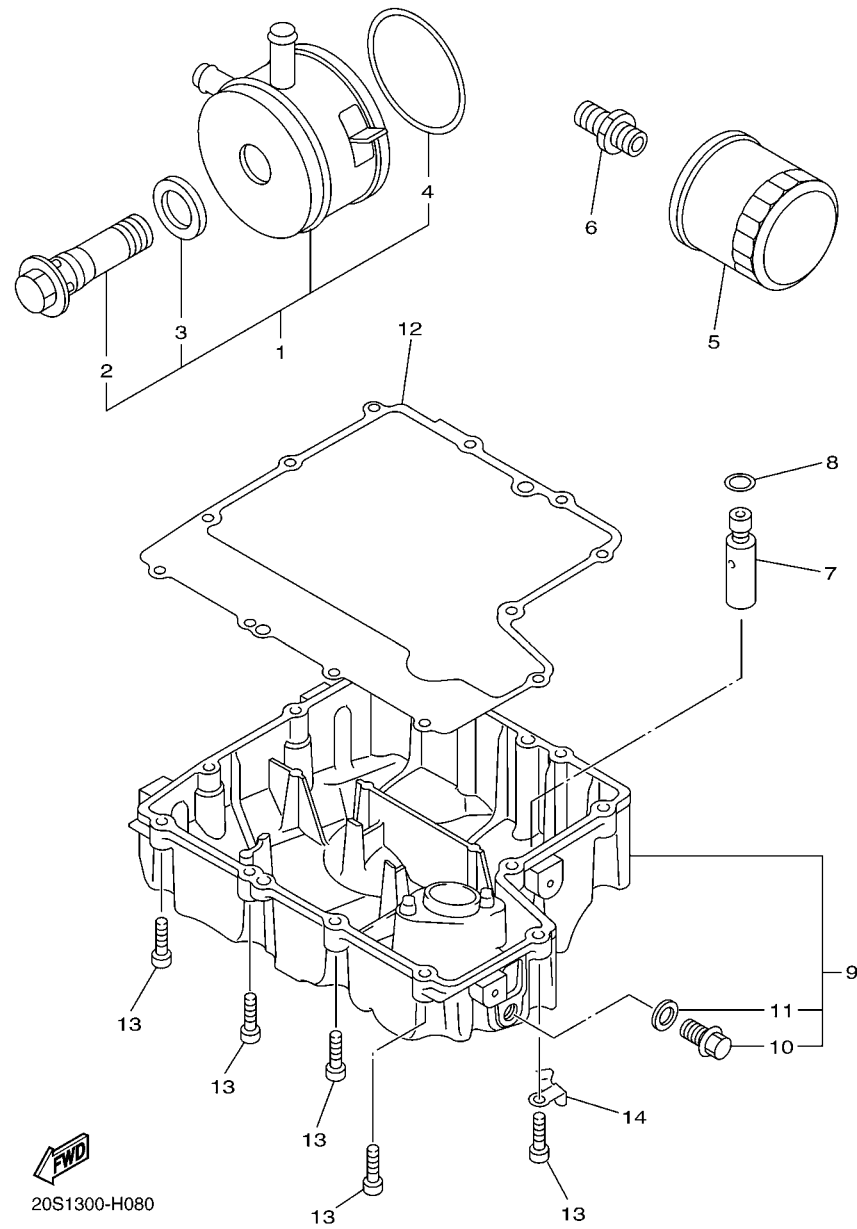
REF. NO.	PART NO.	DESCRIPTION	36P1	36P2	REMARKS
28	22W-12462-00	CAP, RADIATOR	1	1	
29	95802-06025	BOLT, FLANGE	1	1	
30	95802-06030	BOLT, FLANGE	1	1	
31	20S-1244E-00	BRACKET 1	1	1	
32	95822-06012	BOLT, FLANGE	1	1	
33	20S-12589-00	HOSE 6	1	1	
34	90467-200A0	CLIP	2	2	
35	90450-22017	HOSE CLAMP ASSY	1	1	
36	90467-11090	CLIP	1	1	
37	90445-12009	HOSE	1	1	
38	90467-11090	CLIP	2	2	
39	4P5-21871-00	TANK, RECOVERY	1	1	
40	26H-21828-00	ELBOW	2	2	
41	90445-081F2	HOSE (L200)	1	1	
42	3P6-21875-00	CAP	1	1	
43	90445-08025	HOSE	1	1	
44	90467-08075	CLIP	2	2	
45	4P5-2172W-00	COVER	1	1	
46	4P5-21873-00	BRACKET, RECOVERY TANK	1	1	
47	95822-10020	BOLT, FLANGE	1	1	
48	90464-07012	CLAMP	1	1	
49	90467-08075	CLIP	1	1	
50	90105-060A6	BOLT, FLANGE	2	2	
51	90464-10233	CLAMP	1	1	



**FWD**  
5SL1300-B070

**FIG. 7 OIL PUMP**

REF. NO.	PART NO.	DESCRIPTION	36P1	36P2	REMARKS
1	5MT-13300-00	OIL PUMP ASSY	1	1	
2	91808-17032	PIN, DOWEL	2	2	
3	95812-06030	BOLT, FLANGE	3	3	
4	5SL-13410-00	STRAINER HOUSING ASSY	1	1	
5	5EB-13415-00	.SEAL, OIL STRAINER	1	1	
6	94580-25080	CHAIN	1	1	
7	5EB-13898-00	HOLDER	1	1	
8	90110-06161	BOLT, HEXAGON SOCKET HEAD	2	2	
9	2C0-13416-00	PIPE, OIL 1	1	1	
10	93210-14003	O-RING	2	2	
11	90110-06161	BOLT, HEXAGON SOCKET HEAD	2	2	
12	5EB-13161-00	PIPE, DELIVERY 1	1	1	
13	5EB-1316E-00	PIPE, DELIVERY 5	1	1	
14	93210-09165	O-RING	2	2	
15	93210-06667	O-RING	1	1	



20S1300-H080

FIG. 8 OIL CLEANER

REF. NO.	PART NO.	DESCRIPTION	36P1	36P2	REMARKS
1	5EB-13470-00	OIL COOLER ASSY	1	1	
2	5EB-12822-00	.BOLT, UNION	1	1	
3	5EB-13475-00	.GASKET	1	1	
4	5JW-13473-00	.O-RING	1	1	
5	5GH-13440-20	ELEMENT ASSY, OIL CLEANER	1	1	
6	90401-20145	BOLT, UNION	1	1	
7	3KS-13490-00	RELIEF VALVE ASSY	1	1	
8	93210-15566	O-RING	1	1	
9	20S-13400-00	STRAINER COVER ASSY	1	1	
10	90340-14132	.PLUG, STRAIGHT SCREW	1	1	
11	214-11198-01	.GASKET	1	1	
12	20S-13414-00	GASKET, STRAINER COVER	1	1	
13	91312-06025	BOLT	12	12	
14	90465-10030	CLAMP	1	1	

**FIG. 9 INTAKE**

REF. NO.	PART NO.	DESCRIPTION	36P1	36P2				REMARKS
1	20S-13586-00	JOINT, CARBURETOR 1	1	1				
2	20S-13596-00	JOINT, CARBURETOR 2	1	1				
3	91312-06020	BOLT	6	6				
4	90450-63003	HOSE CLAMP ASSY	4	4				
5	20S-14411-00	CASE, AIR CLEANER 1	1	1				
6	20S-14421-00	CASE, AIR CLEANER 2	1	1				
7	20S-14452-00	SEAL	1	1				
8	98902-05020	SCREW, BIND	9	9				
9	20S-14451-00	ELEMENT, AIR CLEANER	1	1				
10	20S-14457-00	SEAL	1	1				
11	20S-14453-00	JOINT, AIR CLEANER 1	2	2				
12	20S-14463-00	JOINT, AIR CLEANER 2	2	2				
13	4D9-1443E-00	PIPE, DRAIN	1	1				
14	90467-10041	CLIP	1	1				
15	90450-53002	HOSE CLAMP ASSY	4	4				
16	90480-12314	GROMMET	1	1				
17	20S-15373-00	PIPE, BREATHER	1	1				
18	90467-15001	CLIP	1	1				
19	8FP-85886-00	SENSOR, AIR TEMPERATURE	1	1				
20	98902-05012	SCREW, BIND	1	1				
21	90387-06205	COLLAR	1	1				
22	90467-14015	CLIP	1	1				
23	5VX-14148-01	PIPE	2	2				
24	90467-17003	CLIP	2	2				
25	90110-06233	BOLT, HEXAGON SOCKET HEAD	1	1				

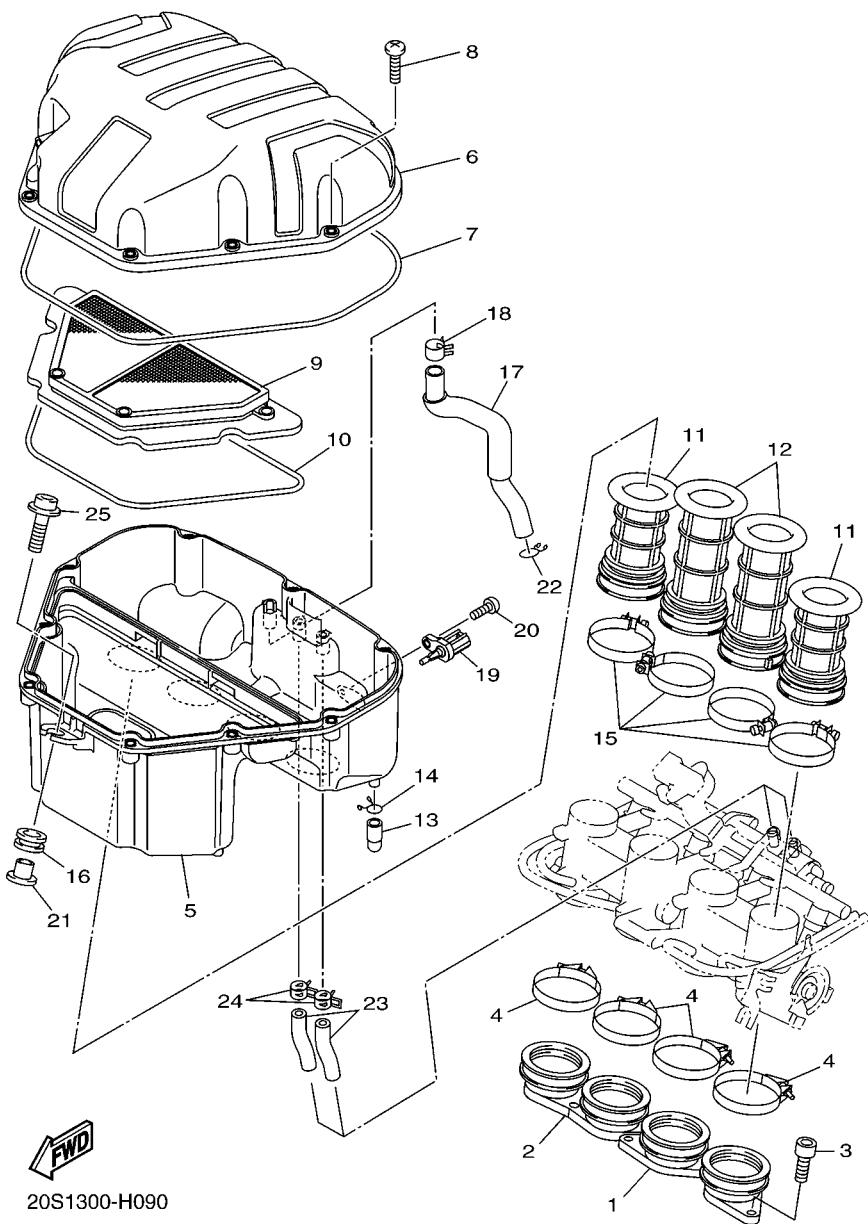
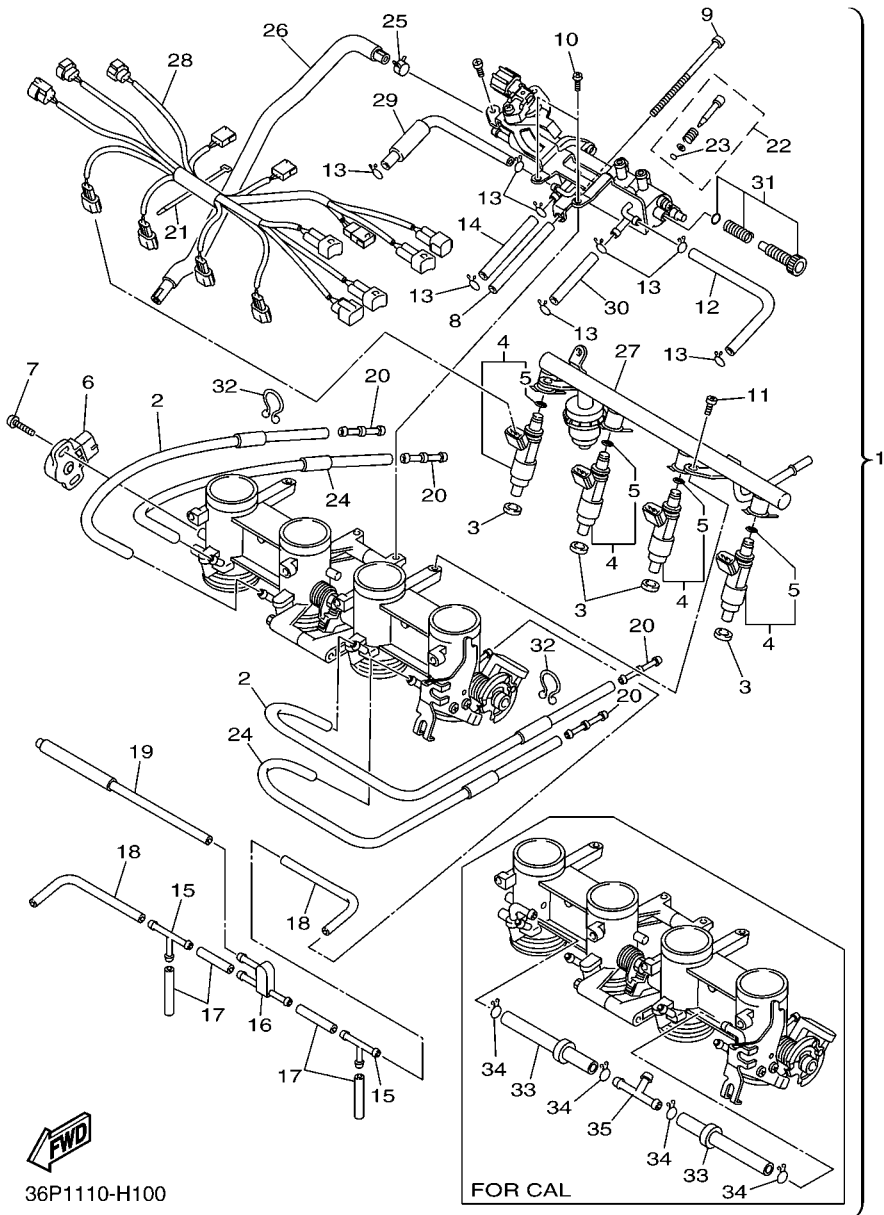


FIG. 10 INTAKE 2

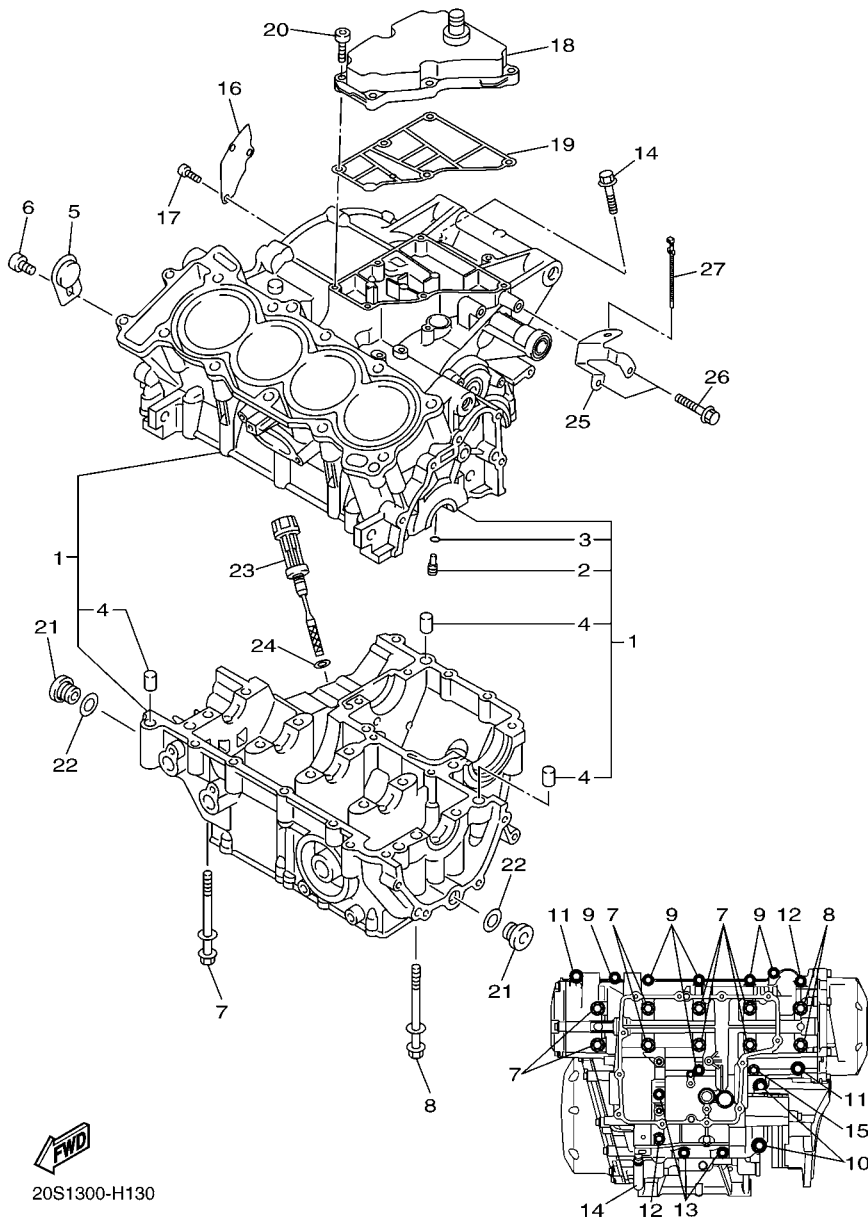
REF. NO.	PART NO.	DESCRIPTION	36P1	36P2	REMARKS
1	20S-13750-00	THROTTLE BODY ASSY	1		
2	5VX-14348-00	.PIPE 1	2	2	
3	8FP-13556-00	.GASKET, MANIFOLD	4	4	
4	5VX-13761-00	.INJECTOR	4	4	
5	5PS-14147-00	..O-RING	1	1	
6	2D1-85885-00	.THROTTLE SENSOR ASSY	1	1	
7	4KM-24453-00	.SCREW	2	2	
8	5VX-14149-00	.PIPE	1	1	
9	5VX-14565-00	.SCREW	1	1	
10	98507-05010	.SCREW, PAN HEAD	2	2	
11	98507-06012	.SCREW, PAN HEAD	2	2	
12	5VX-14396-00	.PIPE	1	1	
13	3UH-14937-00	.CLIP	8	8	
14	5VX-14987-00	.HOSE	1	1	
15	68V-24376-00	.PIPE, JOINT 1	2	2	
16	3XV-14251-00	.NIPPLE	1	1	
17	5FL-14348-10	.PIPE 1	4	4	
18	68V-13533-00	.HOSE, VACUUM SENSING 4	2	2	
19	5VX-1410E-00	.HOSE	1	1	
20	5PW-14251-00	.NIPPLE	4	4	
21	4KM-14137-00	.CLIP	1	1	
22	5JW-14104-00	.AIR SCREW SET	4	4	
23	3H1-14147-00	..O-RING	1	1	
24	5VX-14349-00	.PIPE	2	2	
25	90467-11090	.CLIP	1	1	
26	20S-1243E-00	.HOSE 2	1	1	











20S1300-H130

FIG. 13 CRANKCASE

REF. NO.	PART NO.	DESCRIPTION	36P1	36P2	REMARKS
1	20S-15100-01	CRANKCASE ASSY	1	1	
2	5EB-15155-00	.NOZZLE 3	4	4	
3	93210-04092	.O-RING	4	4	
4	99530-10014	.PIN, DOWEL	3	3	
5	5SL-15189-00	PLUG	1	1	
6	90149-06082	SCREW	1	1	
7	90119-08083	BOLT, WITH WASHER	8	8	
8	90119-08084	BOLT, WITH WASHER	2	2	
9	95812-06055	BOLT, FLANGE	6	6	
10	95812-08065	BOLT, FLANGE	2	2	
11	90109-06168	BOLT	2	2	
12	95812-06065	BOLT, FLANGE	2	2	
13	95812-06045	BOLT, FLANGE	3	3	
14	95812-06100	BOLT, FLANGE	1	1	
15	90105-06145	BOLT, FLANGE	1	1	
16	20S-11165-00	PLATE, BREATHER	1	1	
17	90149-06082	SCREW	3	3	
18	20S-15413-00	COVER	1	1	
19	20S-15462-00	GASKET, CRANKCASE COVER 3	1	1	
20	91312-06025	BOLT	6	6	
21	36Y-15189-00	PLUG	2	2	
22	93210-16325	O-RING	2	2	
23	5EB-15362-00	PLUG, OIL LEVEL	1	1	
24	93210-09165	O-RING	1	1	
25	20S-15544-00	STAY 1	1	1	
26	95022-06012	BOLT, FLANGE	2	2	
27	90464-34002	CLAMP	1	1	

FIG. 14 CRANKCASE COVER 1

REF. NO.	PART NO.	DESCRIPTION	36P1	36P2	REMARKS
1	36P-15411-00	COVER, CRANKCASE 1	1	1	
2	5VX-15451-01	GASKET, CRANKCASE COVER 1	1	1	
3	99530-08012	PIN, DOWEL	2	2	
4	90110-06295	BOLT, HEXAGON SOCKET HEAD	7	7	
5	91314-06030	BOLT, HEXAGON SOCKET HEAD	2	2	
6	90465-08045	CLAMP	1	1	
7	20S-15418-00	COVER, CHAIN CASE	1	1	
8	90110-06329	BOLT, HEXAGON SOCKET HEAD	2	2	
9	90110-06330	BOLT, HEXAGON SOCKET HEAD	1	1	
10	36P-15421-00	COVER, CRANKCASE 2	1	1	
11	3F9-15362-00	PLUG, OIL LEVEL	1	1	
12	93210-27194	O-RING	1	1	
13	20S-15461-00	GASKET, CRANKCASE COVER 2	1	1	
14	93608-17263	PIN, DOWEL	2	2	
15	90110-06295	BOLT, HEXAGON SOCKET HEAD	10	10	
16	36P-15416-00	COVER, OIL PUMP	1	1	
17	90465-14011	CLAMP	1	1	
18	90110-06161	BOLT, HEXAGON SOCKET HEAD	1	1	
19	93210-32172	O-RING	1	1	
20	90340-32004	PLUG, STRAIGHT SCREW	1	1	
21	90430-08143	GASKET	1	1	
22	92014-08014	BOLT, BUTTON HEAD	1	1	
23	20S-15456-00	GASKET, OIL PUMP COVER 1	1	1	
24	90110-06274	BOLT, HEXAGON SOCKET HEAD	7	7	
25	90465-10042	CLAMP	1	1	
26	20S-15425-00	COVER, GENERATOR 2	1	1	
27	93317-11295	BEARING	1	1	

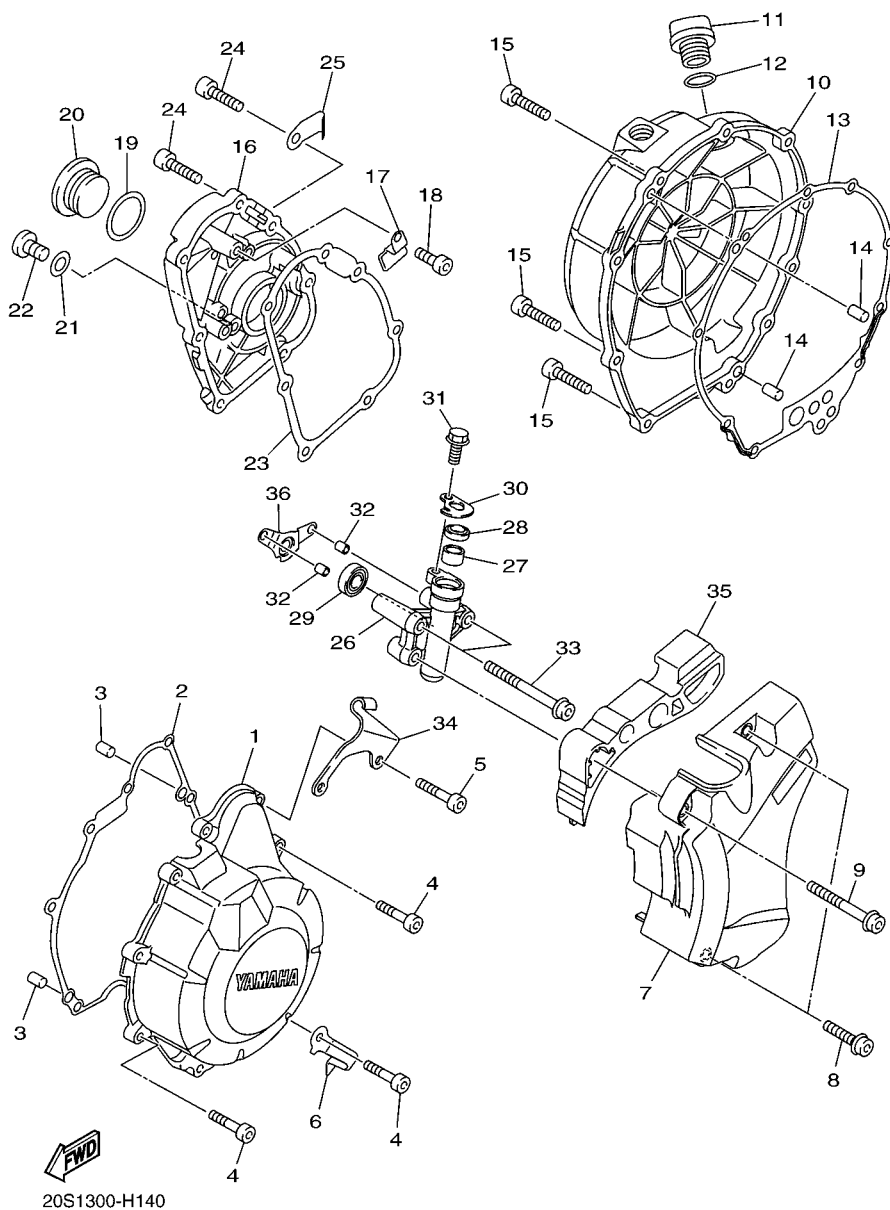
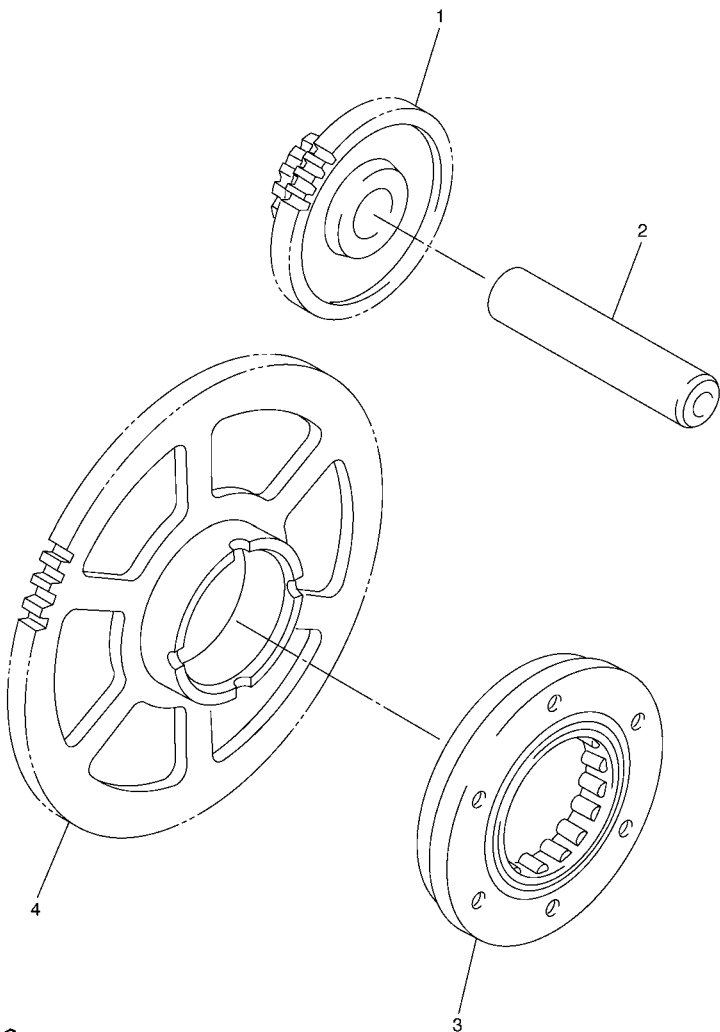




FIG. 15 STARTER

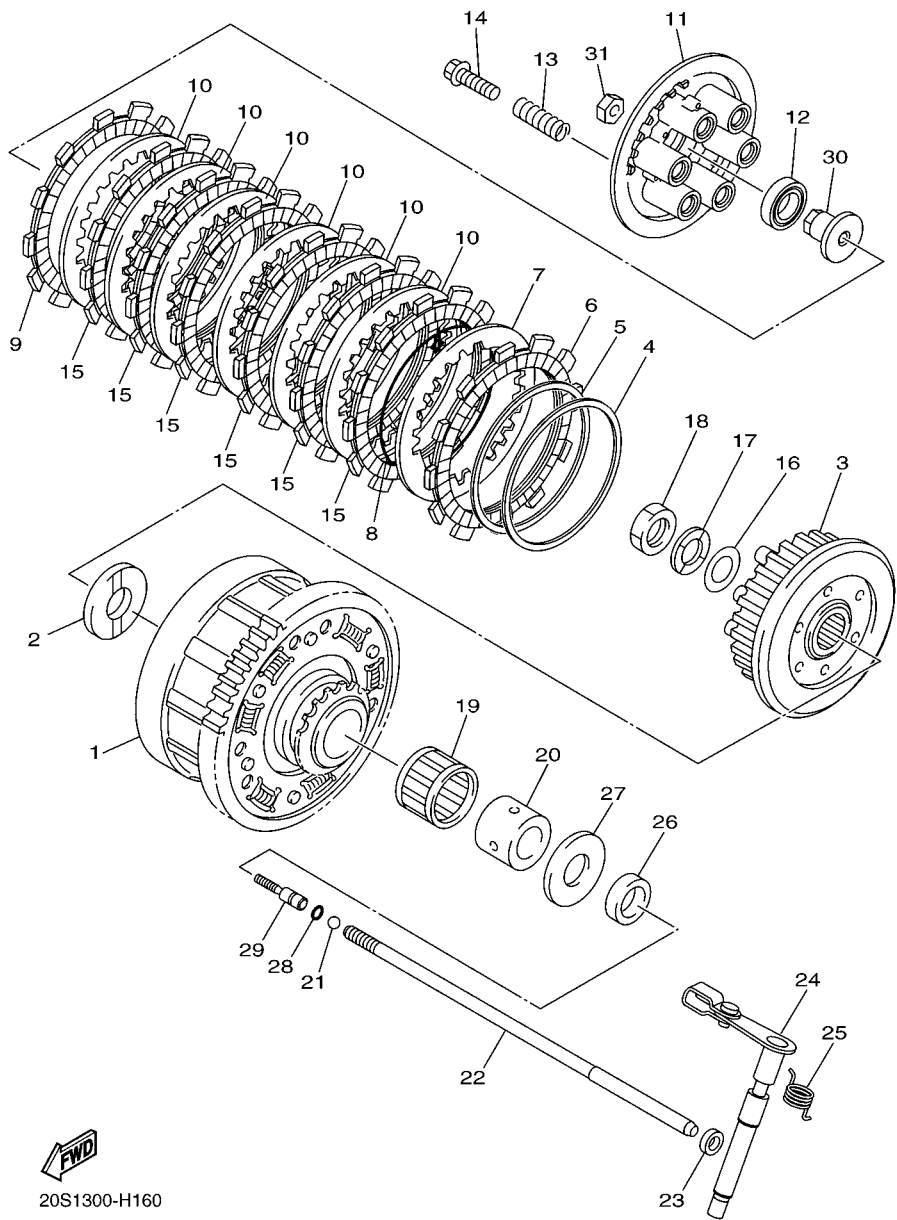
REF. NO.	PART NO.	DESCRIPTION	36P1	36P2				REMARKS
1	20S-15512-00	GEAR, IDLER 1	1	1				
2	5EB-15521-00	SHAFT 1	1	1				
3	5SL-15590-00	STARTER ONE-WAY ASSY	1	1				
4	5MT-15515-00	GEAR 3	1	1				
-----								
-----								
-----								
-----								
-----								
-----								
-----								



5SL1300-B150

FIG. 16 CLUTCH

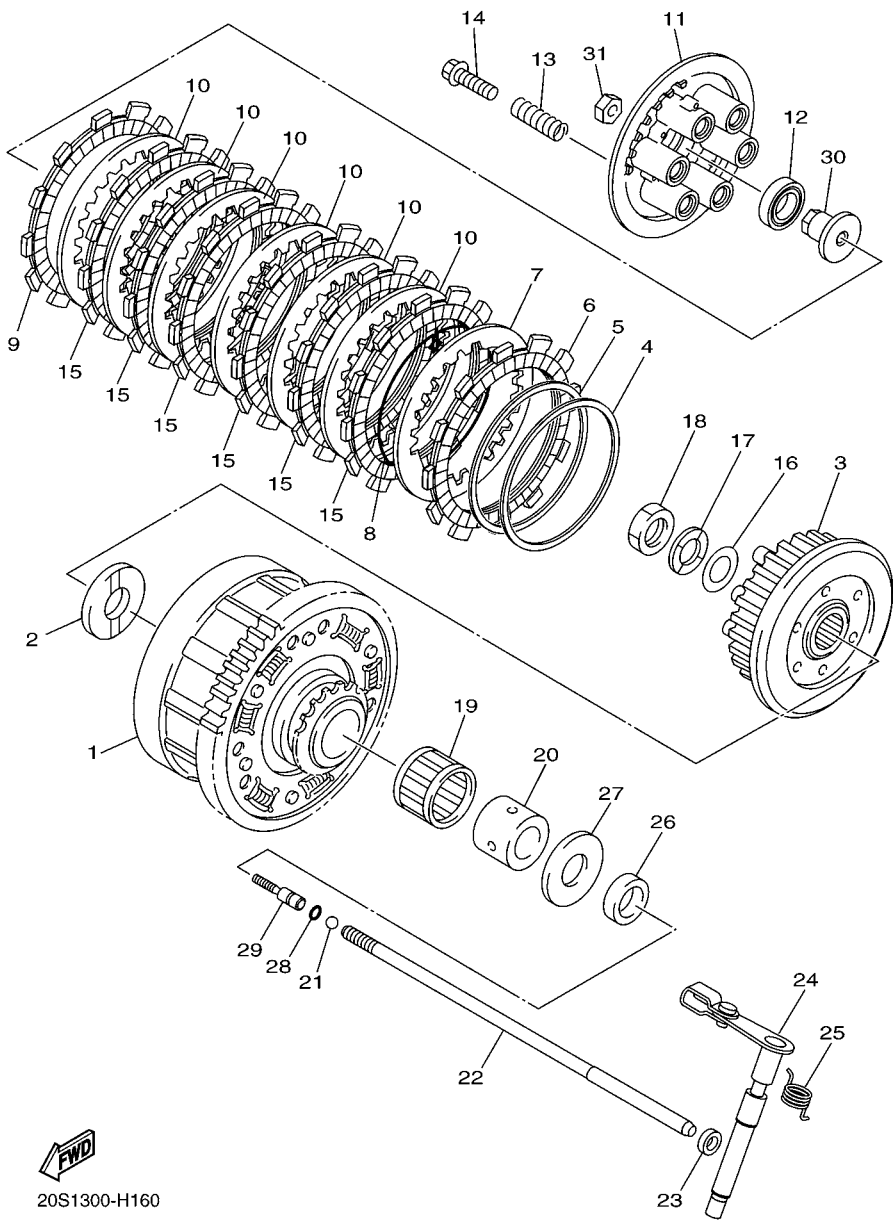
REF. NO.	PART NO.	DESCRIPTION	36P1	36P2	REMARKS
1	20S-16150-00	PRIMARY DRIVEN GEAR COMP.	1	1	
2	5EB-16154-00	PLATE, THRUST 1	1	1	
3	20S-16371-10	BOSS, CLUTCH	1	1	
4	20S-16384-10	PLATE, SEAT	1	1	
5	5LV-16383-00	SPRING, CLUTCH BOSS	1	1	
6	5Y1-16331-01	PLATE, FRICTION 2	1	1	
7	3J2-16324-00	PLATE, CLUTCH 1 (T=2.0)	1	1	
8	1J7-16385-00	RING, CLUTCH BOSS	1	1	
9	4H7-16321-02	PLATE, FRICTION	1	1	
10	3J2-16324-00	PLATE, CLUTCH 1 (T=2.0)	6	6	
11	20S-16351-00	PLATE, PRESSURE 1	1	1	
12	93306-00304	BEARING	1	1	
13	90501-225A9	SPRING, COMPRESSION	6	6	
14	90119-06252	BOLT, WITH WASHER	6	6	
15	5LV-16321-20	PLATE, FRICTION	6	6	
16	90201-20030	WASHER, PLATE	1	1	
17	90208-20001	WASHER, CONICAL SPRING	1	1	
18	90179-20007	NUT	1	1	
19	93310-340N8	BEARING	1	1	
20	90387-25024	COLLAR	1	1	
21	93511-32017	BALL	1	1	
22	20S-16357-00	ROD, PUSH 2	1	1	
23	93109-08061	OIL SEAL	1	1	
24	20S-16380-00	PUSH LEVER ASSY	1	1	
25	90508-18052	SPRING, TORSION	1	1	
26	90201-255A6	WASHER, PLATE	1	1	
27	1AE-16164-00	PLATE, THRUST 2	1	1	



20S1300-H160

FIG. 16 CLUTCH

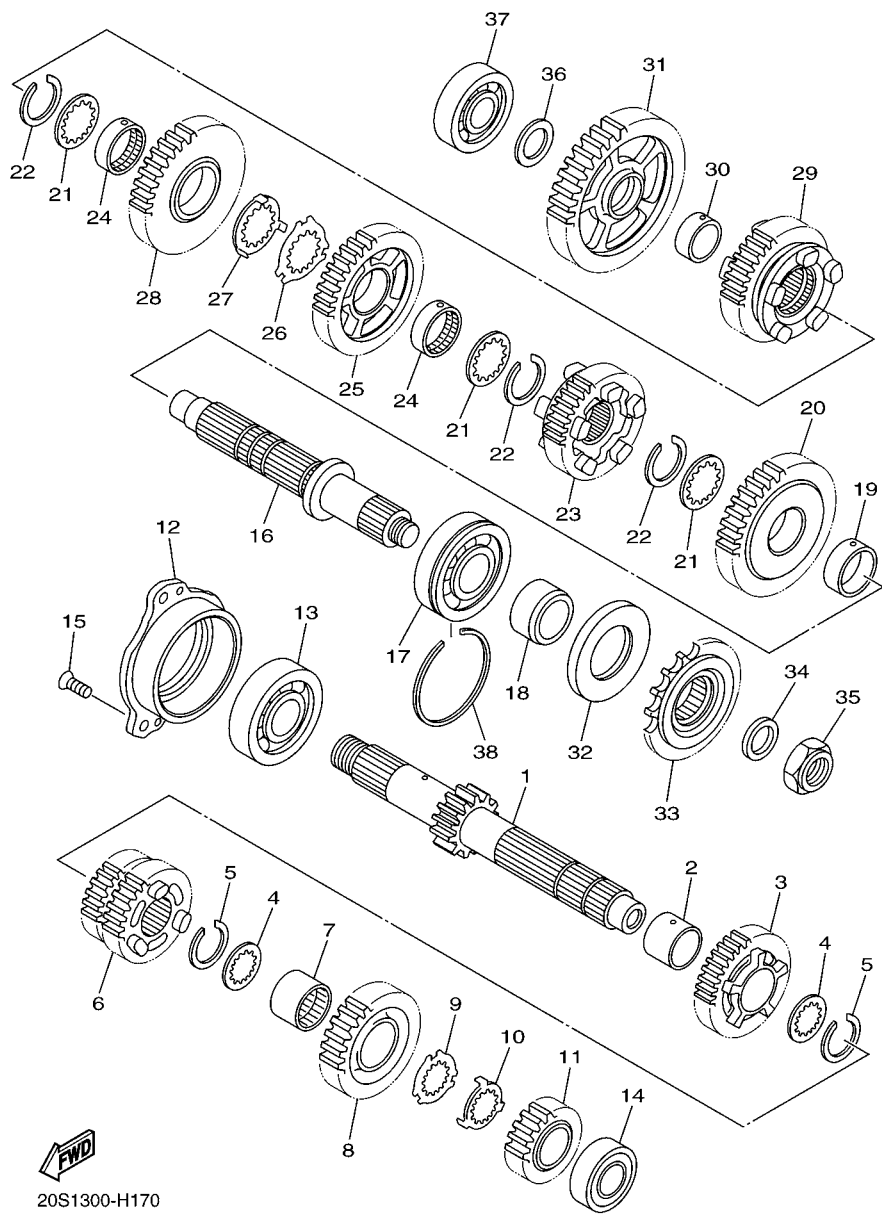
REF. NO.	PART NO.	DESCRIPTION	36P1	36P2	REMARKS
28	93210-06632	O-RING	1	1	
29	20S-16356-00	ROD, PUSH 1	1	1	
30	20S-16358-00	PLATE, PUSH	1	1	
31	95302-06600	NUT	1	1	
-----					
-----					
-----					
-----					
-----					
-----					
-----					
-----					
-----					
-----					



FWD  
20S1300-H160

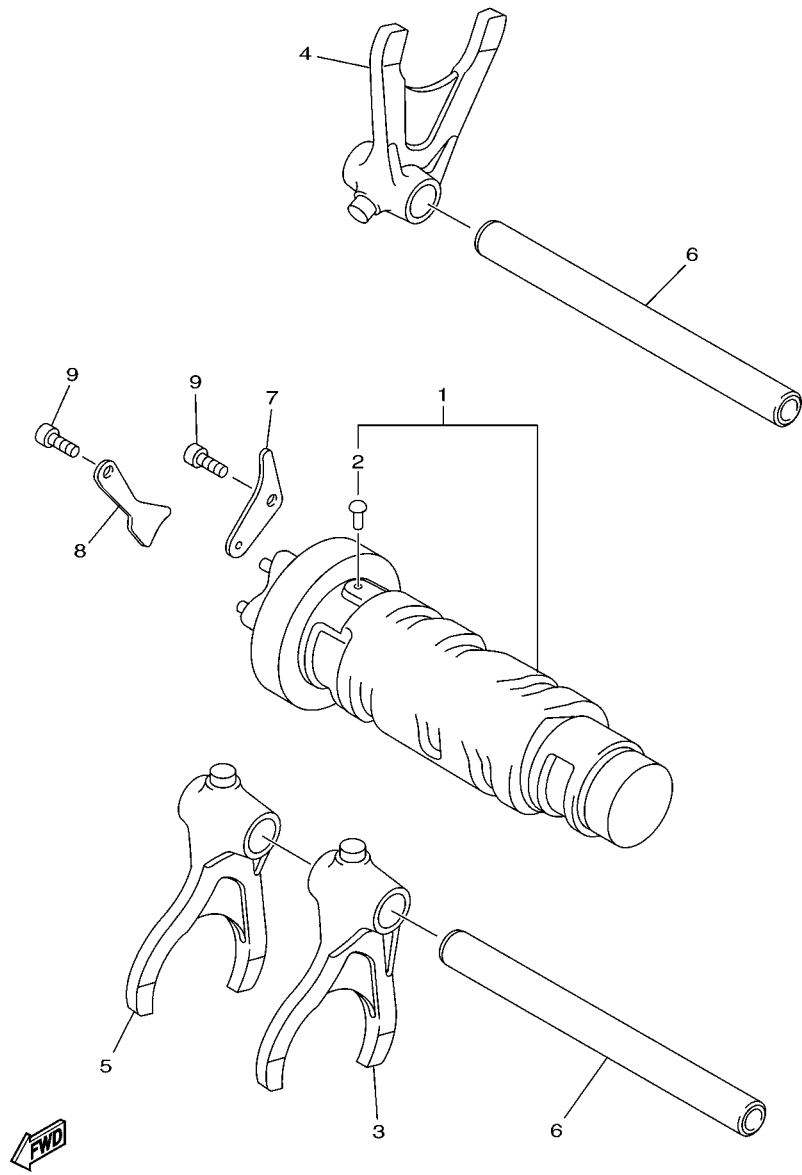
**FIG. 17 TRANSMISSION**

REF. NO.	PART NO.	DESCRIPTION	36P1	36P2	REMARKS
1	20S-17411-00	AXLE, MAIN (13T)	1	1	
2	90387-253M6	COLLAR	1	1	
3	20S-17151-00	GEAR, 5TH PINION (21T)	1	1	
4	90209-21332	WASHER	2	2	
5	93440-25186	CIRCLIP	2	2	
6	20S-17131-00	GEAR, 3RD PINION (18T/24T)	1	1	
7	90387-2513E	COLLAR	1	1	
8	20S-17161-00	GEAR, 6TH PINION (24T)	1	1	
9	90209-22352	WASHER	1	1	
10	90209-21351	WASHER	1	1	
11	20S-17121-00	GEAR, 2ND PINION (19T)	1	1	
12	20S-15163-00	HOUSING, BEARING 1	1	1	
13	93306-30525	BEARING	1	1	
14	93306-20483	BEARING	1	1	
15	90151-06024	SCREW, COUNTERSUNK	3	3	
16	4S8-17421-00	AXLE, DRIVE	1	1	
17	93306-30550	BEARING	1	1	
18	90387-2504A	COLLAR	1	1	
19	90387-2813C	COLLAR	1	1	
20	20S-17221-00	GEAR, 2ND WHEEL (37T)	1	1	
21	90209-25342	WASHER	3	3	
22	93440-28062	CIRCLIP	3	3	
23	20S-17261-00	GEAR, 6TH WHEEL (26T)	1	1	
24	90387-2813D	COLLAR	2	2	
25	20S-17241-00	GEAR, 4TH WHEEL (32T)	1	1	
26	90209-25349	WASHER	1	1	
27	90209-25350	WASHER	1	1	



20S1300-H170





20S1300-H180

FIG. 18 SHIFT CAM & FORK

REF. NO.	PART NO.	DESCRIPTION	36P1	36P2	REMARKS
1	20S-18540-00	SHIFT CAM ASSY	1	1	
2	136-18542-00	.POINT, NEUTRAL	1	1	
3	20S-18511-00	FORK, SHIFT 1	1	1	
4	20S-18512-00	FORK, SHIFT 2	1	1	
5	20S-18513-00	FORK, SHIFT 3	1	1	
6	2C0-18535-00	BAR, SHIFT FORK GUIDE 2	2	2	
7	2C0-18536-00	STOPPER, SHIFT BAR	1	1	
8	2C0-18562-00	PLATE, STOPPER 2	1	1	
9	90110-06182	BOLT, HEXAGON SOCKET HEAD	2	2	
-----					
-----					
-----					
-----					
-----					
-----					
-----					
-----					
-----					



20S1300-H190

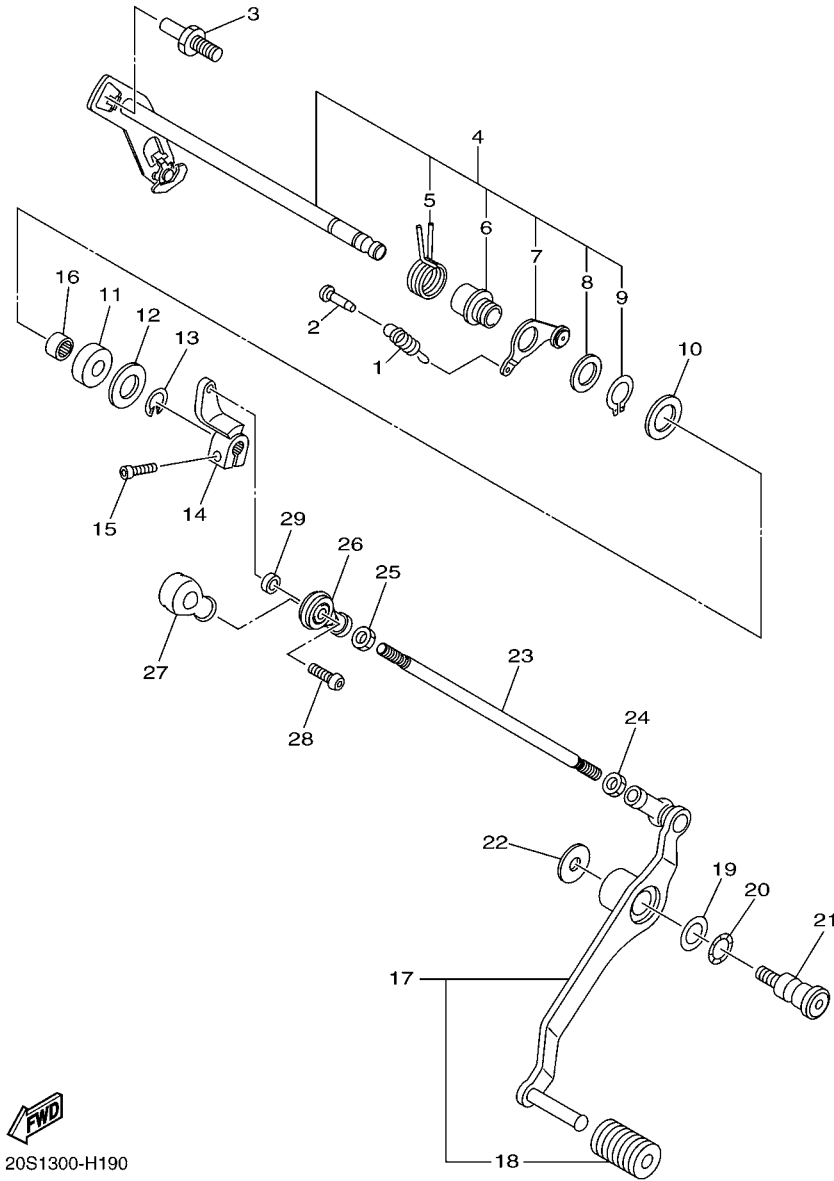


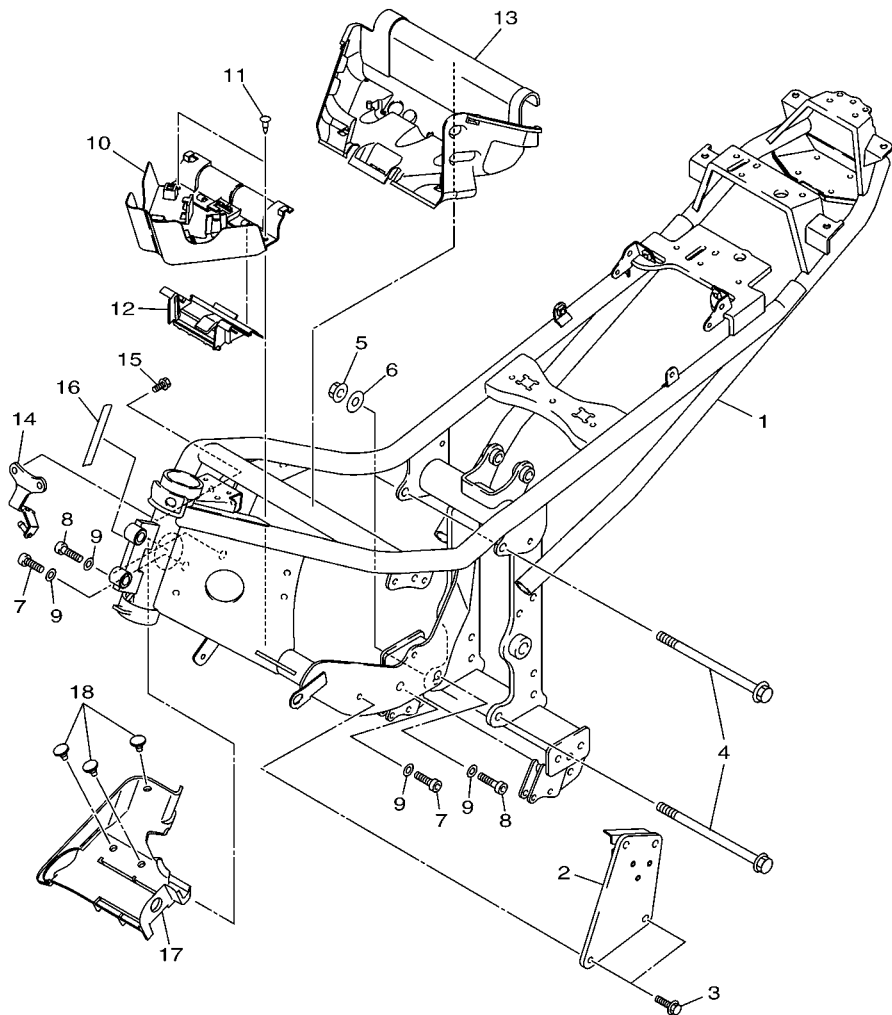
FIG. 19 SHIFT SHAFT

REF. NO.	PART NO.	DESCRIPTION	36P1	36P2	REMARKS
1	90506-15005	SPRING, TENSION	1	1	
2	132-16346-00	HOOK, SPRING	1	1	
3	1D7-18127-00	STOPPER, SCREW	1	1	
4	20S-18101-00	SHIFT SHAFT ASSY	1	1	
5	90508-32020	.SPRING, TORSION	1	1	
6	2C0-18175-00	.SPACER	1	1	
7	20S-18140-00	.STOPPER LEVER ASSY	1	1	
8	90201-177G4	.WASHER, PLATE	1	1	
9	99009-17400	.CIRCLIP	1	1	
10	90201-127E1	WASHER, PLATE	1	1	
11	93102-12106	OIL SEAL (SD 12-22-5 HS)	1	1	
12	90201-12575	WASHER, PLATE	1	1	
13	99001-10600	CIRCLIP	1	1	
14	20S-18112-00	ARM, SHIFT	1	1	
15	91312-06020	BOLT	1	1	
16	93317-11295	BEARING	1	1	
17	20S-18110-00	SHIFT PEDAL ASSY	1	1	
18	5EB-18113-00	.COVER, SHIFT PEDAL	1	1	
19	90201-12051	WASHER, PLATE	1	1	
20	90206-12005	WASHER, WAVE	1	1	
21	4BP-27434-01	BOLT	1	1	
22	90201-08053	WASHER, PLATE	1	1	
23	3D8-18115-00	ROD, SHIFT	1	1	
24	90170-06026	NUT	1	1	
25	95314-06700	NUT	1	1	
26	5VX-18116-00	JOINT, ROD 1	1	1	
27	5VX-18154-00	COVER, DUST	1	1	



FIG. 20 FRAME

REF. NO.	PART NO.	DESCRIPTION	36P1	36P2	REMARKS
1	36P-21110-00	FRAME COMP.	1	1	
2	20S-21136-00	GUSSET	1	1	
3	95822-08020	BOLT, FLANGE	4	4	
4	90105-10297	BOLT, FLANGE	2	2	
5	90179-10658	NUT	2	2	
6	90201-10051	WASHER, PLATE	2	2	
7	91312-10035	BOLT	2	2	
8	91312-10045	BOLT	2	2	
9	90201-10030	WASHER, PLATE	4	4	
10	20S-2117N-00	COVER 3	1	1	
11	90269-07007	RIVET	2	2	
12	20S-2117R-00	COVER 4	1	1	
13	20S-2117T-00	COVER 5	1	1	
14	20S-21249-00	BRACKET	1	1	
15	95802-06010	BOLT, FLANGE	2	2	
16	3D8-2117G-00	PROTECTOR	1	1	
17	36P-2117U-00	COVER 6	1	1	
18	90269-05074	RIVET	3	3	



36P1110-H200

FIG. 21 FENDER

REF. NO.	PART NO.	DESCRIPTION	36P1	36P2	REMARKS
1	5VX-21511-A0-P3	FENDER, FRONT	1		FOR SMX
2	90387-065J6	COLLAR	4	4	
3	90480-12072	GROMMET	4	4	
4	90464-18002	CLAMP	1	1	
5	90154-06061	SCREW, BINDING	2	2	
6	95024-06030	BOLT, FLANGE	2	2	
7	95702-06500	NUT, FLANGE	2	2	
8	20S-21611-00	FENDER, REAR	1	1	
9	90183-06053	NUT, SPRING	2	2	
10	120-82131-00	BAND, BATTERY	1	1	
11	90480-07003	GROMMET	2	2	
12	5JW-2174X-00	DAMPER	1	1	
13	95802-06012	BOLT, FLANGE	2	2	
14	90269-07010	RIVET	2	2	
15	95822-06010	BOLT, FLANGE	1	1	
16	20S-21629-10	GUARD, MUD	1	1	
17	3Y6-85130-02	REAR REFLECTOR ASSY	1	1	
18	95602-05100	NUT, U	1	1	
19	90201-05043	WASHER, PLATE	1	1	
20	20S-21688-00	BRACKET, REAR STAY	1	1	
21	90464-31001	CLAMP	3	3	
22	90160-05012	SCREW, ROUND TAPPING	4	4	
23	90480-23345	GROMMET	1	1	
24	8GC-2836B-01	TUNING FORK MARK	1	1	
25	90269-07001	RIVET	2	2	
26	90387-06232	COLLAR	4	4	

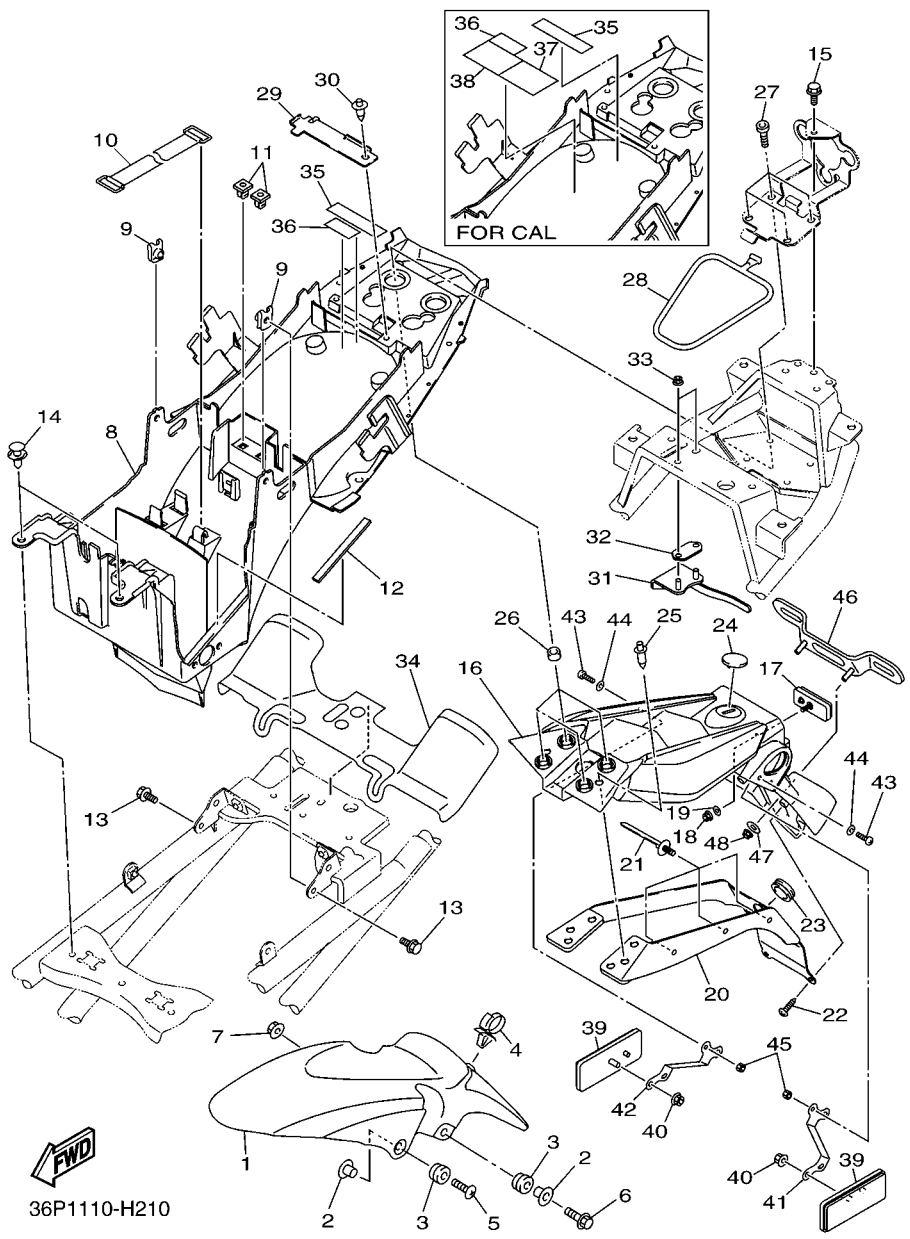
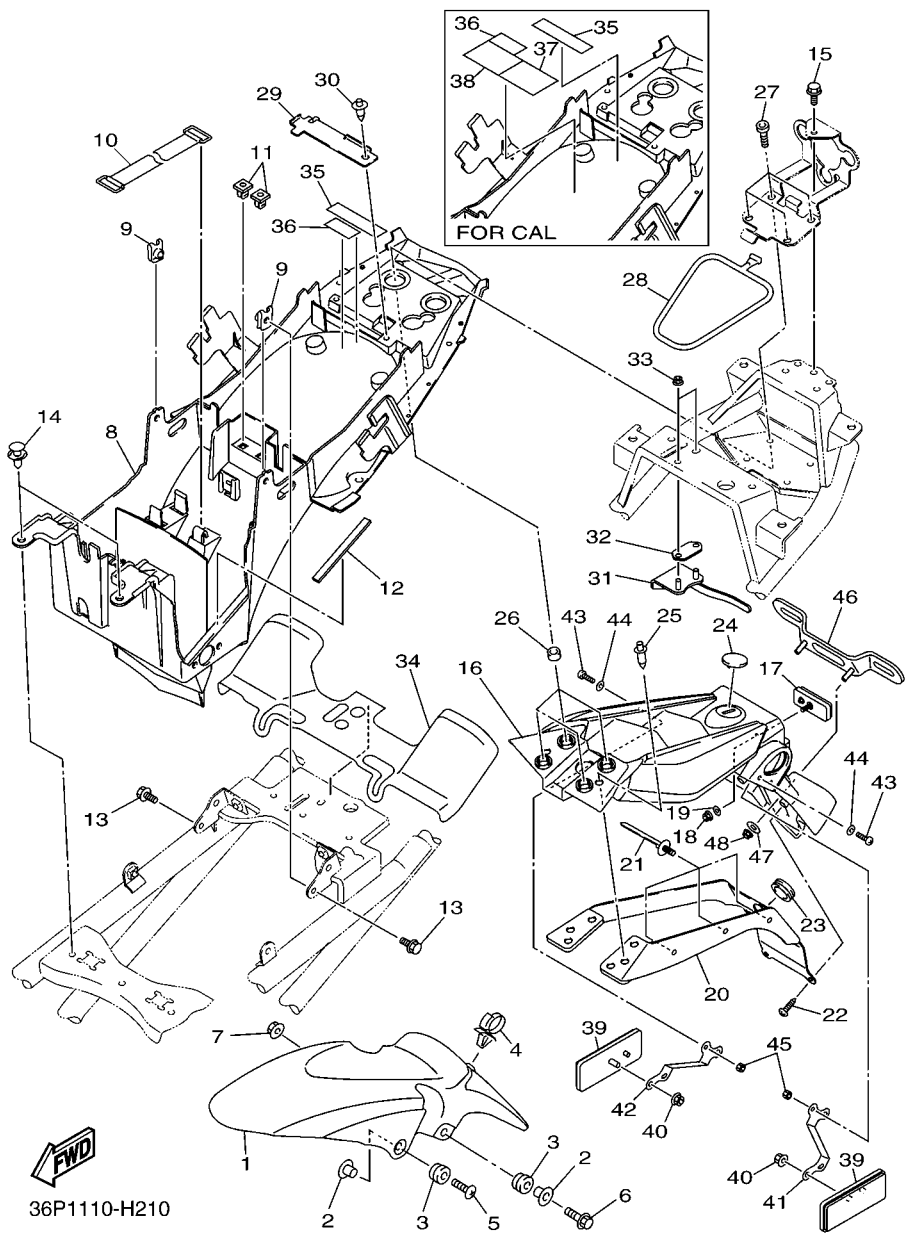
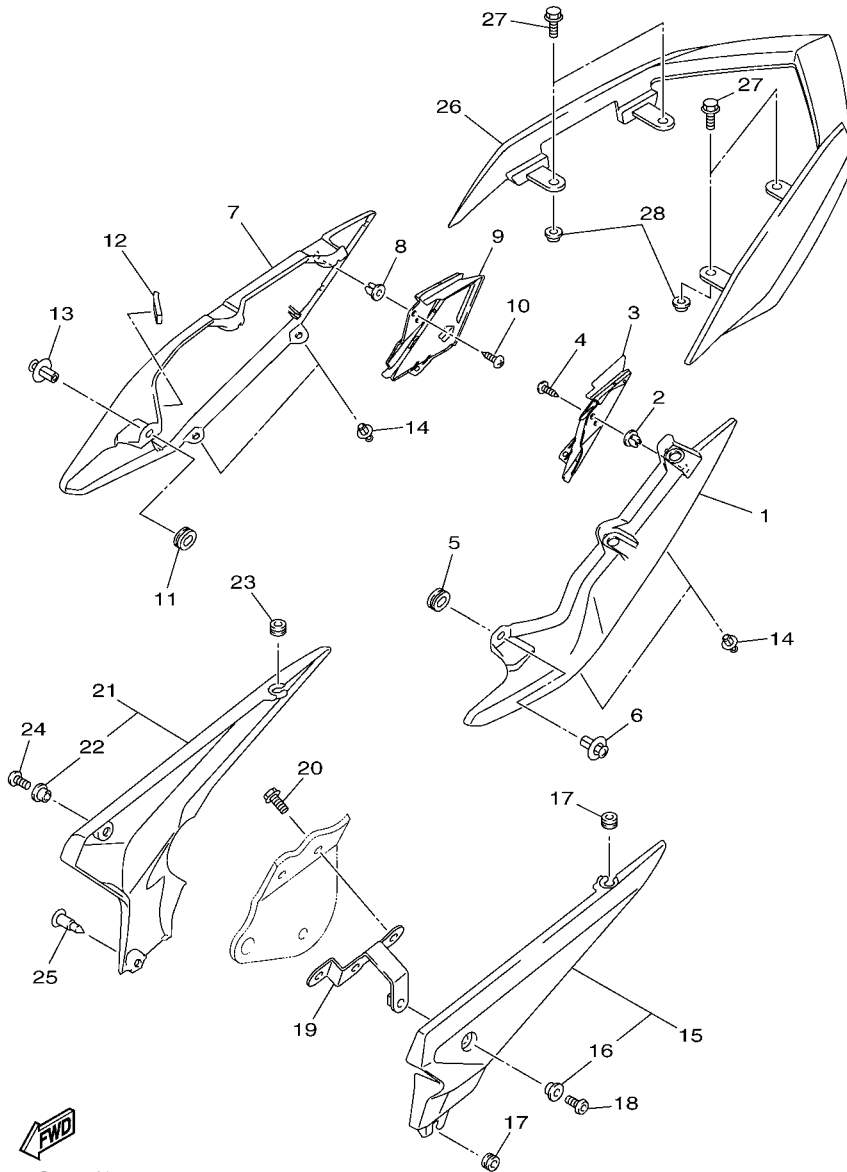


FIG. 21 FENDER

REF. NO.	PART NO.	DESCRIPTION			REMARKS
			36P1	36P2	
27	91312-08025	BOLT	4	4	
28	3YX-21376-00	BAND, TOOL	1	1	
29	20S-21677-00	PLATE, FITTING 3	1	1	
30	90269-06008	RIVET	1	1	
31	36P-2115J-00	BRACKET, HELMET HANGER	1	1	
32	20S-24792-00	PLATE	1	1	
33	95702-06500	NUT, FLANGE	2	2	
34	36P-21639-00	DAMPER 2	1	1	
35	3JJ-28446-A1	LABEL, CAUTION	1	1	
36	3TB-24877-A0	LABEL, CAUTION	1	1	
39	3Y6-85130-02	REAR REFLECTOR ASSY	2	2	
40	95602-05200	NUT, SELF-LOCKING	2	2	
41	36P-2164F-00	STAY 1	1	1	
42	36P-2164G-00	STAY 2	1	1	
43	98502-04012	SCREW, PAN HEAD	4	4	
44	92902-04600	WASHER, PLATE	4	4	
45	95602-04100	NUT, U	4	4	
46	5MT-84751-00	BRACKET, LICENSE	1	1	
47	90201-06088	WASHER, PLATE	2	2	
48	95602-06100	NUT, U	2	2	



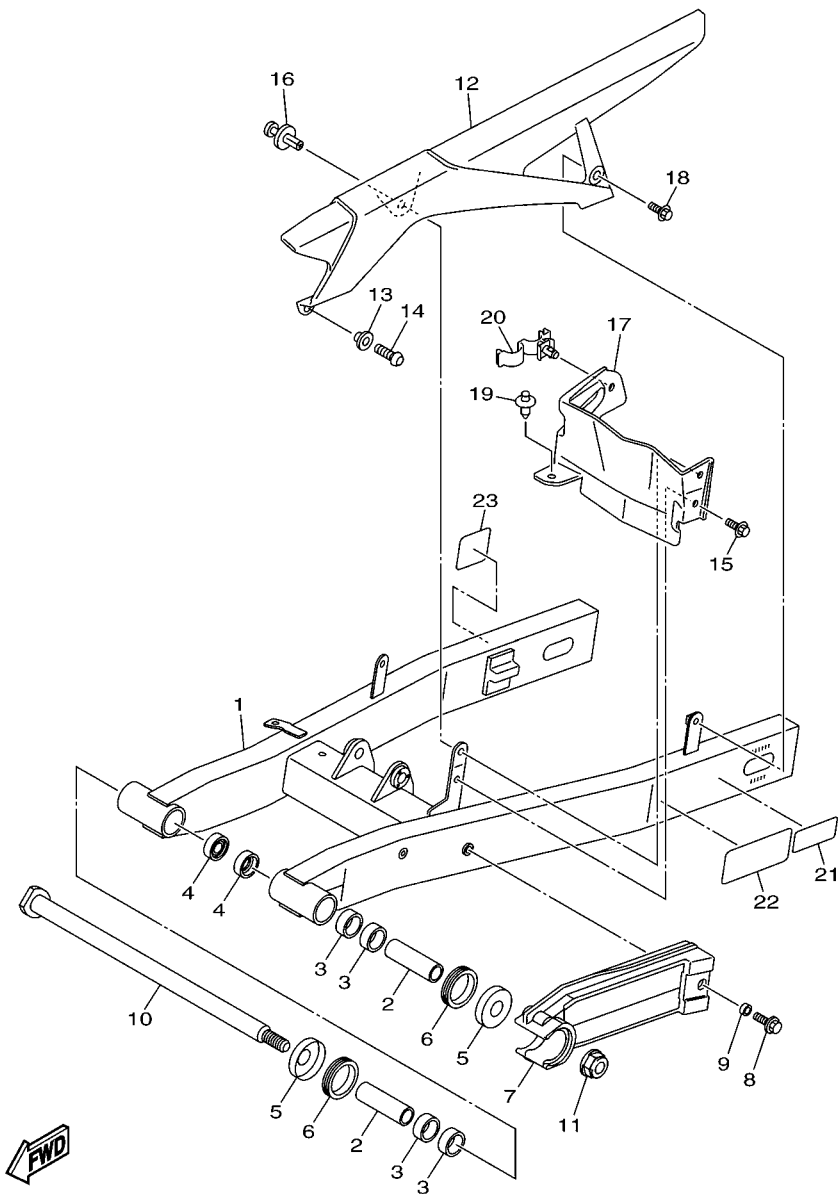


20S1300-H220

FIG. 22 SIDE COVER

REF. NO.	PART NO.	DESCRIPTION	36P1	36P2	REMARKS
1	20S-21711-00-P3	COVER, SIDE 1	1		FOR SMX
2	90480-08005	GROMMET	1	1	
3	20S-2163A-00	COVER, REAR FENDER 1	1	1	
4	97702-50014	SCREW, TAPPING	1	1	
5	5PW-2174X-00	DAMPER	1	1	
6	90269-07076	RIVET	1	1	
7	20S-21721-00-P3	COVER, SIDE 2	1		FOR SMX
8	90480-08005	GROMMET	1	1	
9	20S-2163E-00	COVER, REAR FENDER 2	1	1	
10	97702-50014	SCREW, TAPPING	1	1	
11	5PW-2174X-00	DAMPER	1	1	
12	4C8-24182-00	DAMPER, LOCATING 2	1	1	
13	90269-07076	RIVET	1	1	
14	90269-07077	RIVET	4	4	
15	20S-21730-00	SIDE COVER ASSY 3	1	1	
16	90387-06130	.COLLAR	1	1	
17	90480-10334	GROMMET	2	2	
18	90111-06038	BOLT,HEX. SOCKET BUTTON	1	1	
19	20S-2172U-00	BRKT 7	1	1	
20	95802-06012	BOLT, FLANGE	2	2	
21	20S-21740-00	SIDE COVER ASSY 4	1	1	
22	90387-06130	.COLLAR	1	1	
23	90480-10334	GROMMET	1	1	
24	90111-06038	BOLT,HEX. SOCKET BUTTON	1	1	
25	90269-07008	RIVET	1	1	





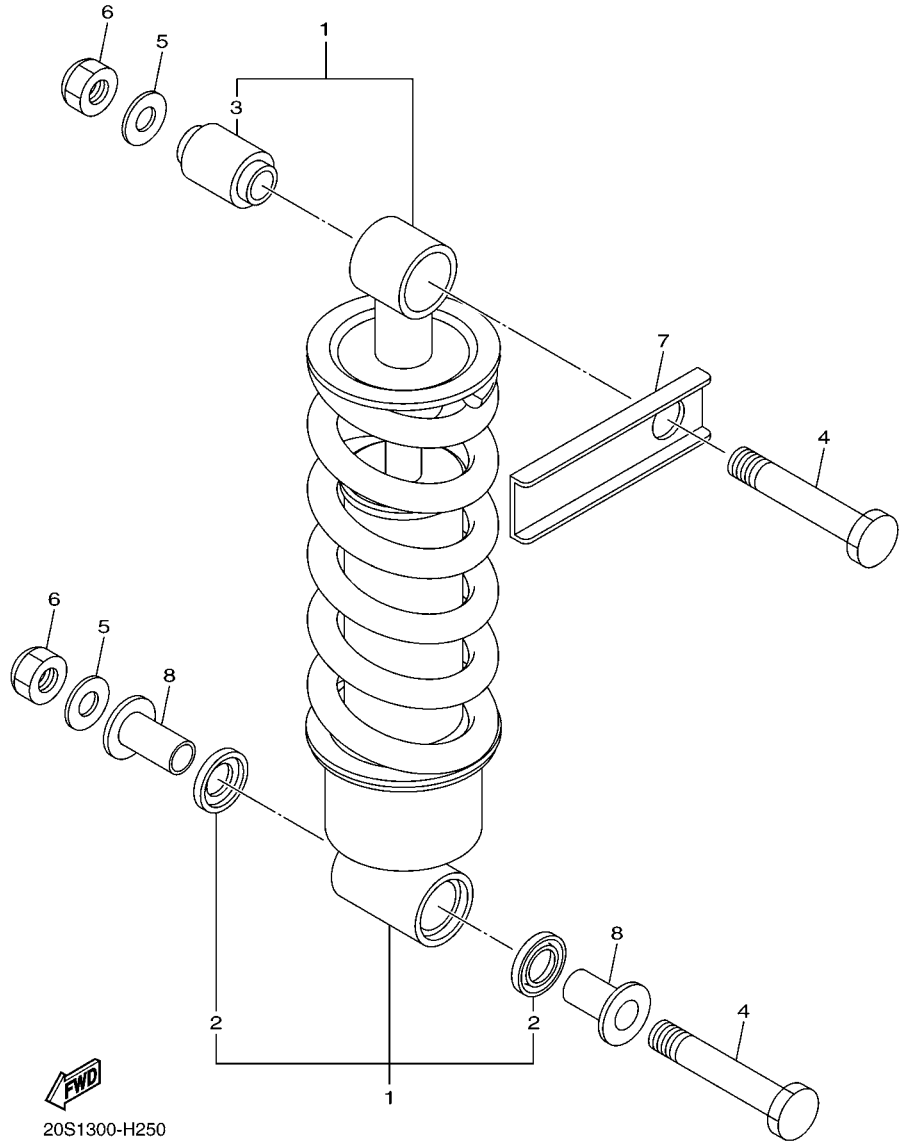
36P1110-H230

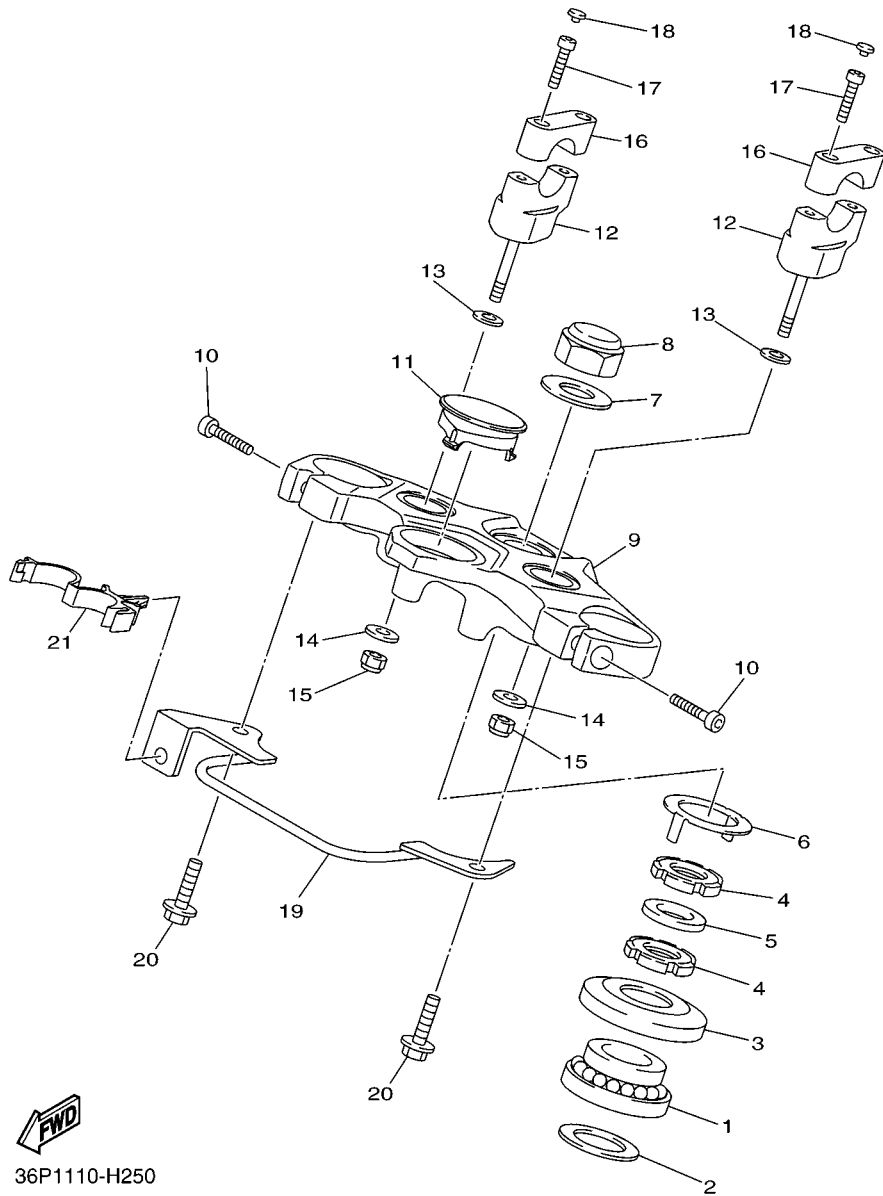
FIG. 23 REAR ARM

REF. NO.	PART NO.	DESCRIPTION	36P1	36P2			REMARKS
1	20S-22110-00	REAR ARM COMP.	1	1			
2	5VK-22124-00	BUSH 2	2	2			
3	93317-22262	BEARING	4	4			
4	93106-22019	OIL SEAL (DC 22-28-8)	2	2			
5	30X-2219X-00	COVER	2	2			
6	93108-35004	OIL SEAL (35-41-8)	2	2			
7	20S-22151-00	SEAL, GUARD	1	1			
8	90119-06147	BOLT, WITH WASHER	1	1			
9	90387-06133	COLLAR	1	1			
10	1AE-22141-00	SHAFT, PIVOT	1	1			
11	90185-14012	NUT, SELF-LOCKING	1	1			
12	20S-22311-00	CASE, CHAIN	1	1			
13	90387-06130	COLLAR	1	1			
14	92012-06020	BOLT, BUTTON HEAD	1	1			
15	90119-06154	BOLT, WITH WASHER	1	1			
16	90269-07076	RIVET	1	1			
17	20S-22325-01	COVER, DUST	1	1			
18	90119-06154	BOLT, WITH WASHER	1	1			
19	90269-08001	RIVET	1	1			
20	90464-16011	CLAMP	1	1			
21	3XW-21668-A1	LABEL, TIRE	1	1			
22	36P-2179W-00	PLATE, EPA (NON CALIFORNIA)	1				

**FIG. 24 REAR SUSPENSION**

REF. NO.	PART NO.	DESCRIPTION			REMARKS
			36P1	36P2	
1	20S-22210-10	SHOCK ABSORBER ASSY, REAR	1	1	
2	93109-18020	.OIL SEAL	2	2	
3	34L-22216-00	.BUSH, REAR SHOCK ABSORBER	1	1	
4	90109-125F1	BOLT	2	2	
5	90201-12050	WASHER, PLATE	2	2	
6	95612-12100	NUT, U	2	2	
7	20S-22243-00	WASHER 1	1	1	
8	90387-123X6	COLLAR	2	2	
-----					
-----					
-----					
-----					
-----					
-----					
-----					
-----					





**FWD**  
36P1110-H250

**FIG. 25 STEERING**

REF. NO.	PART NO.	DESCRIPTION	36P1	36P2	REMARKS
1	93399-99931	BEARING	1	1	
2	90202-24190	WASHER, PLATE	1	1	
3	1W1-23416-00	COVER, BALL RACE 2	1	1	
4	90179-25033	NUT	2	2	
5	90202-26142	WASHER, PLATE	1	1	
6	26H-23418-01	WASHER, SPECIAL	1	1	
7	90201-220T0	WASHER, PLATE	1	1	
8	90176-22081	NUT, CROWN	1	1	
9	20S-W2341-10	CROWN, HANDLE	1	1	
10	91312-08030	BOLT	2	2	
11	36P-82552-00	CAP, SWITCH	1	1	
12	5LV-23442-01	HOLDER, HANDLE LOWER	2	2	
13	92907-10200	WASHER, PLAIN	2	2	
14	90201-10141	WASHER, PLATE	2	2	
15	95602-10100	NUT, U	2	2	
16	4H7-23441-01-98	HOLDER, HANDLE UPPER	2	2	LGB
17	91312-08030	BOLT	4	4	
18	341-23469-00	CAP, BOLT	4	4	
19	36P-23318-00	HOLDER, CABLE 1	1	1	
20	95802-06012	BOLT, FLANGE	2	2	
21	90464-16006	CLAMP	1	1	

FIG. 26 FRONT FORK

REF. NO.	PART NO.	DESCRIPTION	36P1	36P2	REMARKS
1	20S-23102-10	FRONT FORK ASSY (L.H)	1	1	
2	20S-23110-00	.INNER TUBE COMP.1	1	1	
3	3VD-23135-10	..METAL, SLIDE 2	1	1	
4	20S-23170-00	.CYLINDER COMP., FRONT FORK	1	1	
5	20S-23126-10	.TUBE, OUTER (LEFT)	1	1	
6	3VD-23151-00	.SPRING, REBOUND	1	1	
7	5VU-23173-00	.SPINDLE, TAPER	1	1	
8	3VD-23125-10	.METAL, SLIDE 1	1	1	
9	5VU-23145-00	.OIL SEAL	1	1	
10	3VD-23115-00	.GUIDE, COVER UPPER	1	1	
11	3VD-23156-00	.RING, SNAP	1	1	
12	3VD-23144-00	.SEAL, DUST	1	1	
13	20S-23141-00	.SPRING, FRONT FORK	1	1	
14	5VU-2311H-00	.FORK BOLT	1	1	
15	93210-35N02	.O-RING	1	1	
16	90430-10171	.GASKET	1	1	
17	90110-10N52	.BOLT, HEXAGON SOCKET HEAD	1	1	
18	5VU-23118-00	.SPACER	1	1	
19	5VU-23142-00	.SEAT, SPRING UPPER	1	1	
20	4TX-2331G-00	.COVER	1	1	
21	20S-23103-10	FRONT FORK ASSY (R.H)	1	1	
22	20S-23110-00	.INNER TUBE COMP.1	1	1	
23	3VD-23135-10	..METAL, SLIDE 2	1	1	
24	20S-23170-00	.CYLINDER COMP., FRONT FORK	1	1	
25	20S-23136-10	.TUBE, OUTER (RIGHT)	1	1	
26	3VD-23151-00	.SPRING, REBOUND	1	1	
27	5VU-23173-00	.SPINDLE, TAPER	1	1	

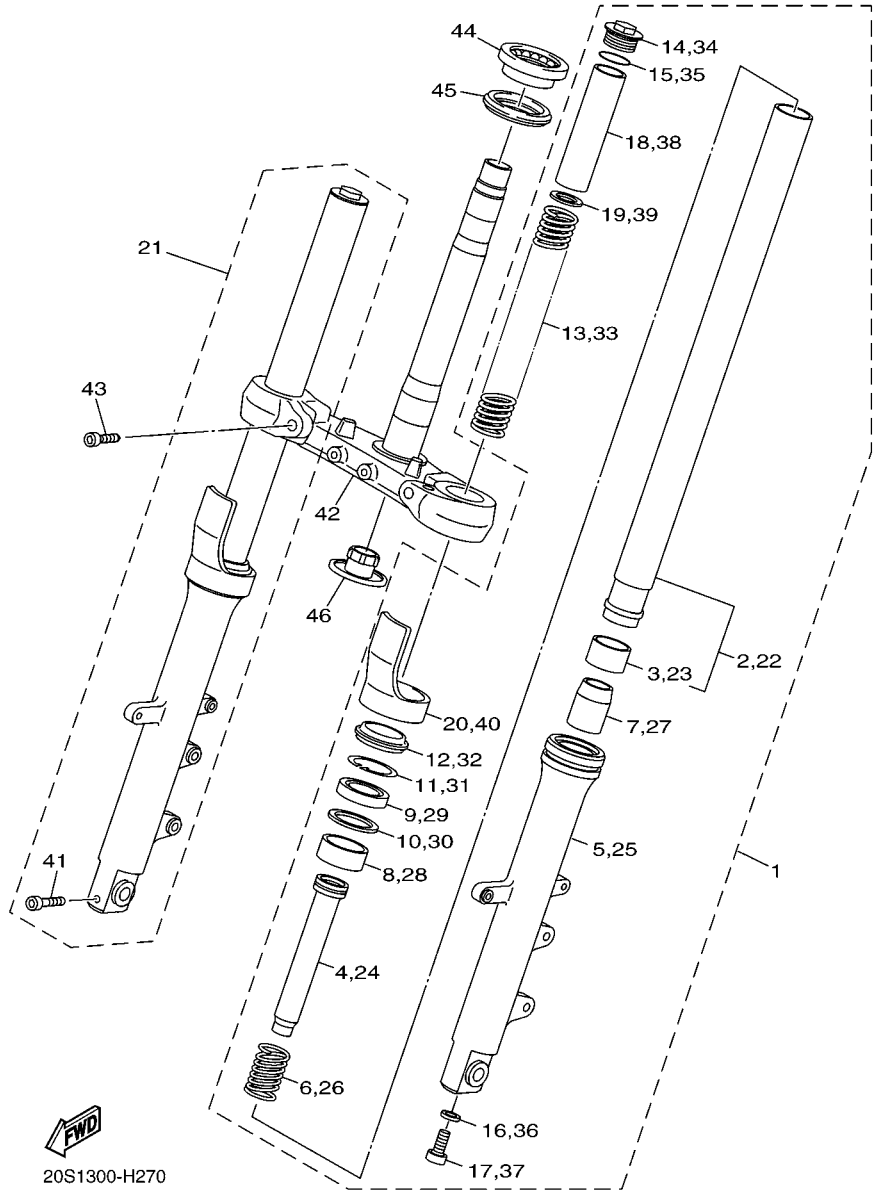
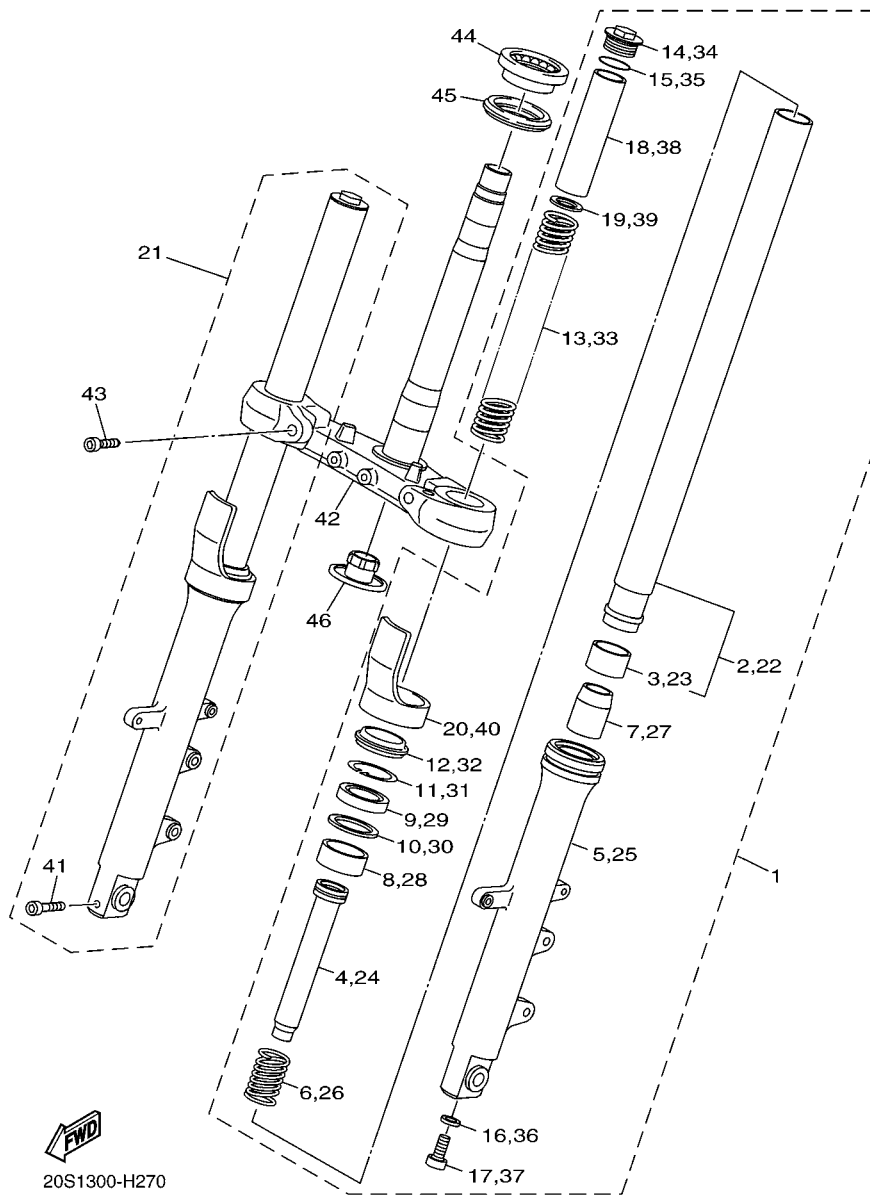
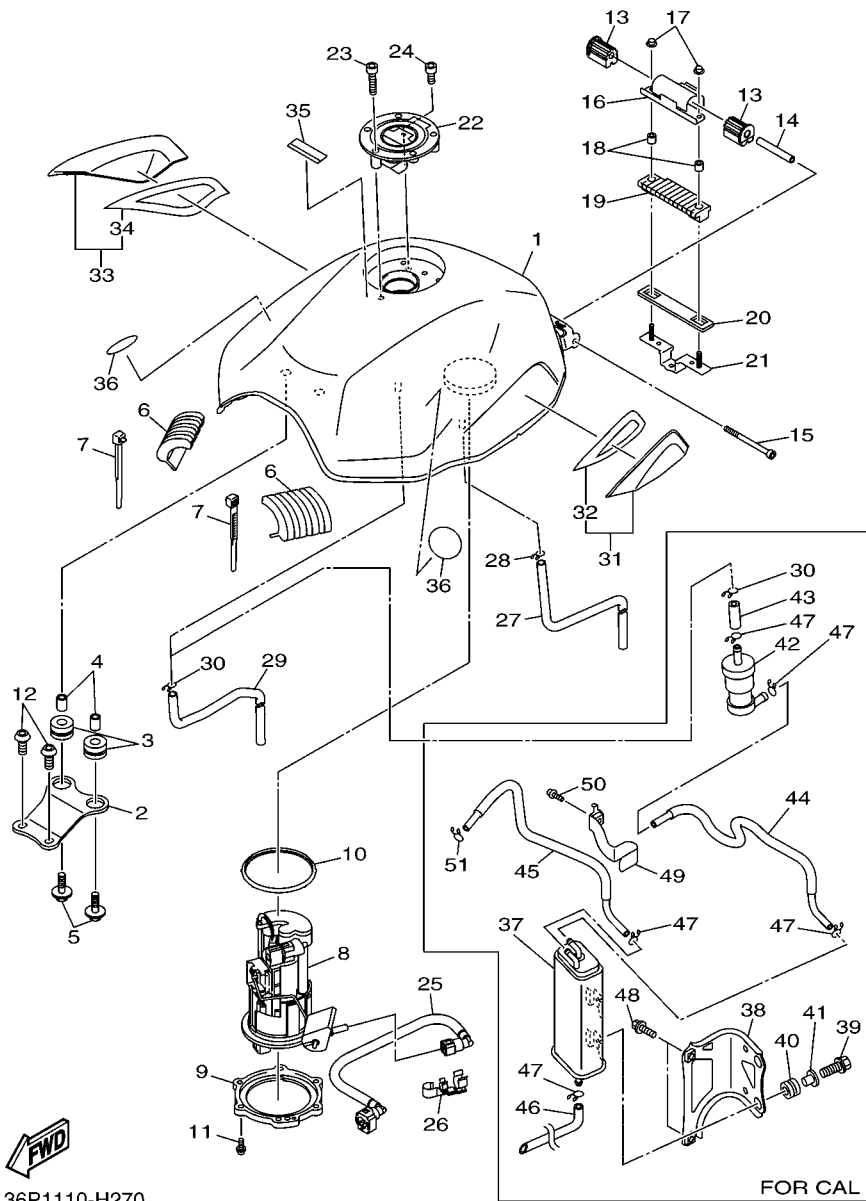


FIG. 26 FRONT FORK

REF. NO.	PART NO.	DESCRIPTION			REMARKS
			36P1	36P2	
28	3VD-23125-10	.METAL, SLIDE 1	1	1	
29	5VU-23145-00	.OIL SEAL	1	1	
30	3VD-23115-00	.GUIDE, COVER UPPER	1	1	
31	3VD-23156-00	.RING, SNAP	1	1	
32	3VD-23144-00	.SEAL, DUST	1	1	
33	20S-23141-00	.SPRING, FRONT FORK	1	1	
34	5VU-2311H-00	.FORK BOLT	1	1	
35	93210-35N02	.O-RING	1	1	
36	90430-10171	.GASKET	1	1	
37	90110-10N52	.BOLT, HEXAGON SOCKET HEAD	1	1	
38	5VU-23118-00	.SPACER	1	1	
39	5VU-23142-00	.SEAT, SPRING UPPER	1	1	
40	4TX-2331G-00	.COVER	1	1	
41	91314-08040	.BOLT, HEXAGON SOCKET HEAD	1	1	
42	20S-23340-10	UNDER BRACKET COMP.	1	1	
43	91312-10025	BOLT	2	2	
44	93399-99932	BEARING	1	1	
45	3FV-23462-00	SEAL, STEERING	1	1	
46	4KM-23123-01	COVER, UNDER 1	1	1	



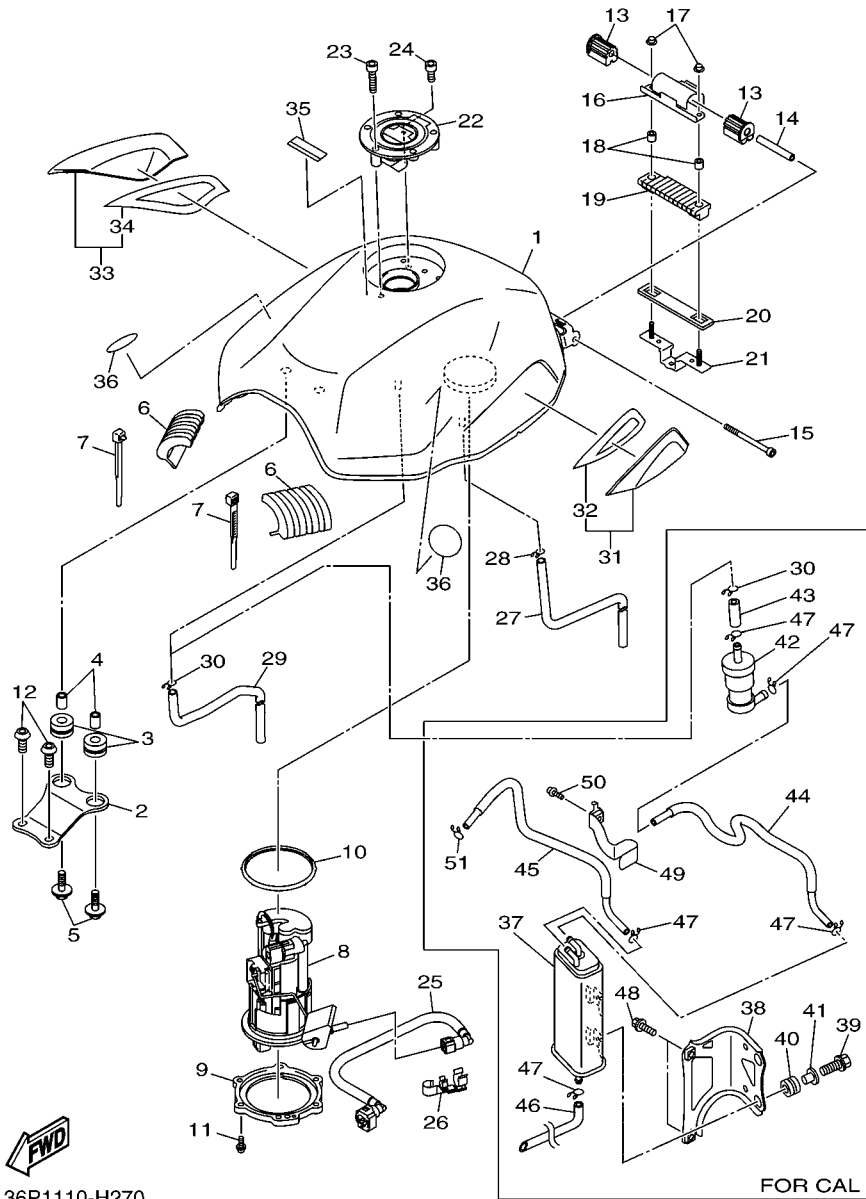


**FWD**  
36P1110-H270

**FIG. 27 FUEL TANK**

REF. NO.	PART NO.	DESCRIPTION	36P1	36P2	REMARKS
1	20S-YK241-00-P0	FUEL TANK COMP.	1		FOR SMX
2	20S-24191-00	BRACKET, FUEL TANK 1	1	1	
3	90480-16010	GROMMET	2	2	
4	90387-06068	COLLAR	2	2	
5	90119-06062	BOLT, WITH WASHER	2	2	
6	20S-24183-00	DAMPER, LOCATING 3	2	2	
7	90465-15011	CLAMP	4	4	
8	20S-13907-00	FUEL PUMP COMP.	1	1	
9	13S-24491-00	BRACKET, FUEL PUMP	1	1	
10	5JW-24486-00	O-RING	1	1	
11	90110-05028	BOLT, HEXAGON SOCKET HEAD	6	6	
12	90111-06127	BOLT, HEX. SOCKET BUTTON	2	2	
13	5VX-24181-00	DAMPER, LOCATING 1	2	2	
14	90387-061W6	COLLAR	1	1	
15	91312-06090	BOLT	1	1	
16	20S-2413Y-00	BRACKET, TANK FITTING	1	1	
17	95702-06500	NUT, FLANGE	2	2	
18	90387-06299	COLLAR	2	2	
19	20S-24181-00	DAMPER, LOCATING 1	1	1	
20	20S-2414H-00	DAMPER, PLATE 1	1	1	
21	20S-21296-00	NUT	1	1	
22	5JJ-24602-00	CAP ASSY	1	1	
23	90110-05112	BOLT, HEXAGON SOCKET HEAD	3	3	
24	91317-05010	BOLT	1	1	
25	5VX-13971-00	PIPE, FUEL 1	1	1	
26	90464-16005	CLAMP	1	1	

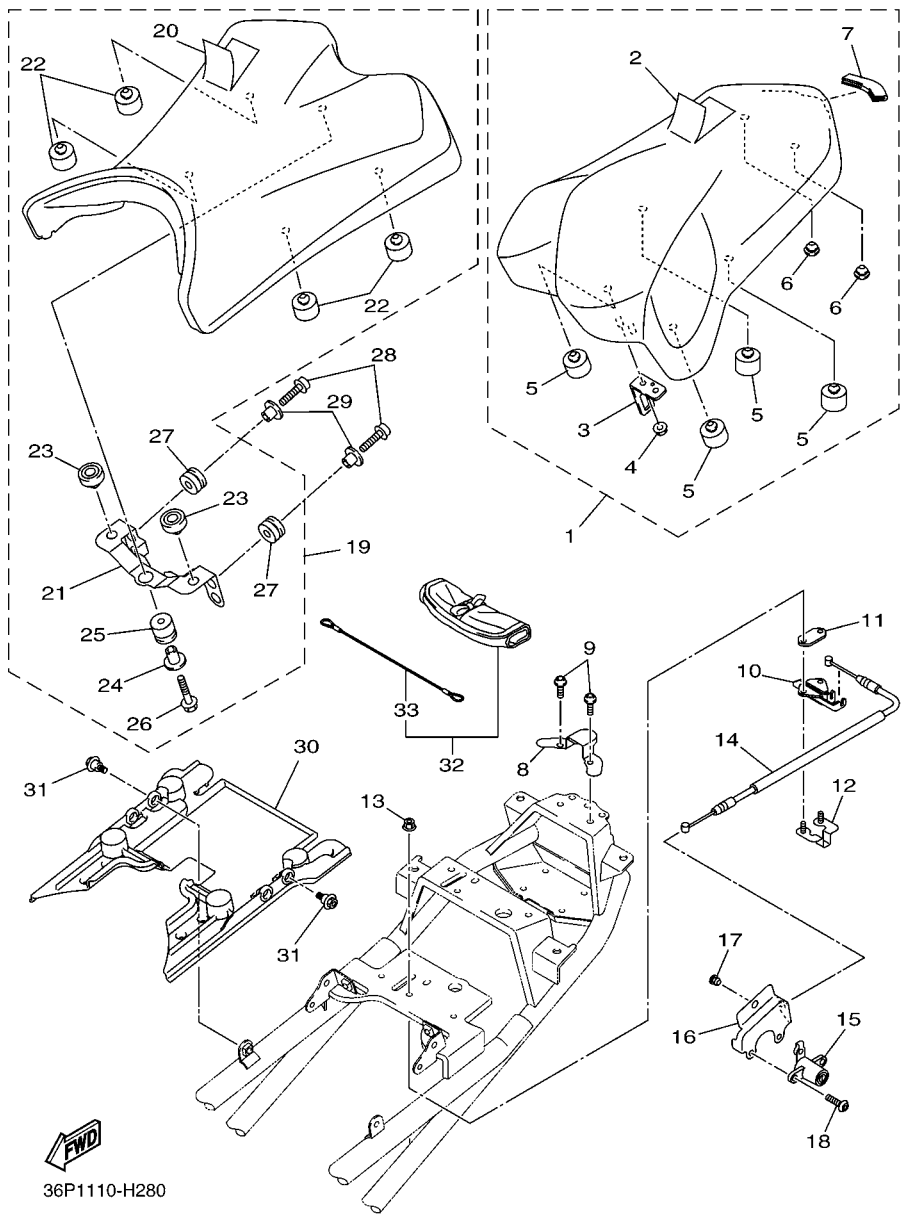
**FIG. 27 FUEL TANK**



36P1110-H270

REF. NO.	PART NO.	DESCRIPTION			REMARKS
			36P1	36P2	
27	90445-106J2	HOSE (L650)	1	1	
28	90467-090A2	CLIP	1	1	
29	90445-106J2	HOSE (L650)	1		
30	90467-090A2	CLIP	1		
31	20S-24106-00	TANK SIDE COVER ASSY 1	1	1	
32	20S-2173T-00	.TAPE 1	1	1	
33	20S-24108-00	TANK SIDE COVER ASSY 2	1	1	
34	20S-2173U-00	.TAPE 2	1	1	
36	5JW-2413B-00	EMBLEM	2	2	
-----					
-----					
-----					
-----					
-----					
-----					

FIG. 28 SEAT

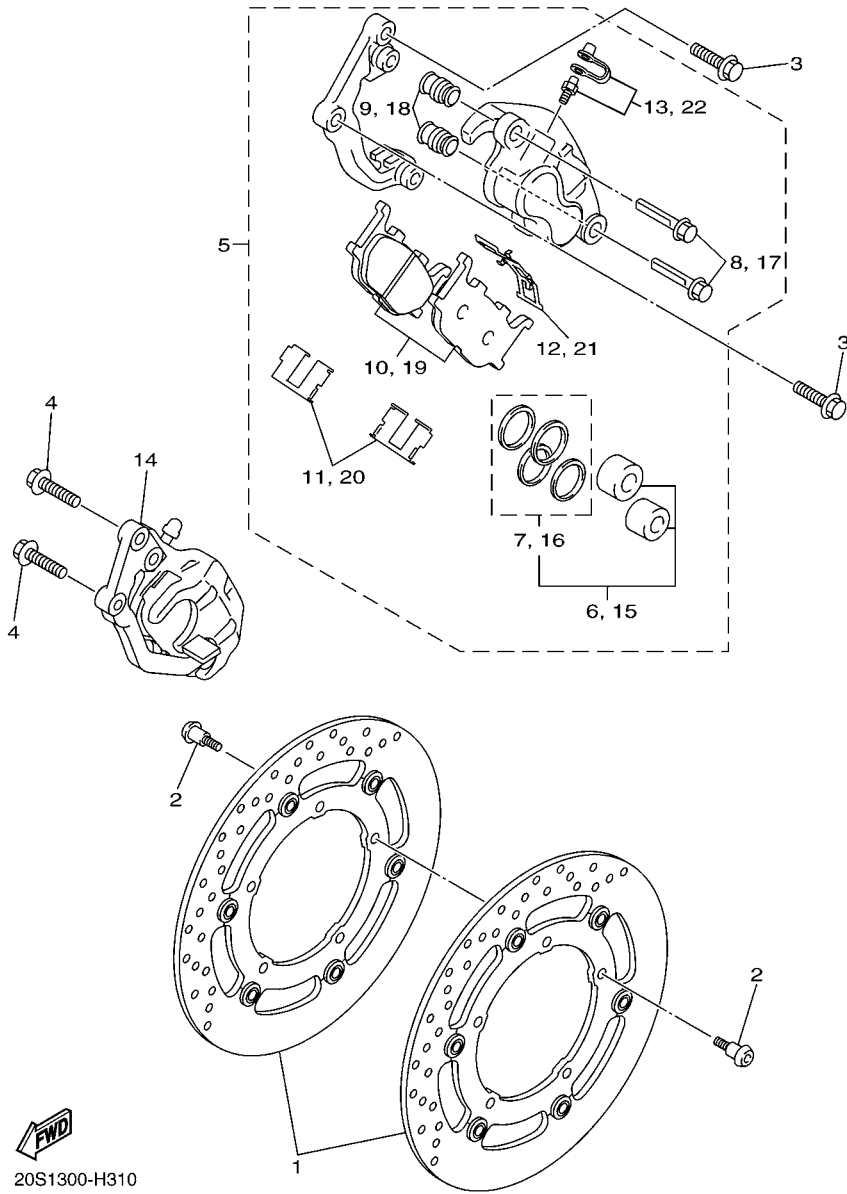


36P1110-H280

REF. NO.	PART NO.	DESCRIPTION	36P1	36P2				REMARKS
1	36P-24750-00	TANDEM SEAT ASSY	1	1				
2	36P-2470H-00	.SEAT COVER COMP.,2	1	1				
3	4NK-24728-00	.BRACKET, SEAT	1	1				
4	95702-06500	.NUT, FLANGE	1	1				
5	4D9-27114-00	.STOPPER, MAIN STAND	4	4				
6	90338-07043	.PLUG	2	2				
7	36P-24724-00	.DAMPER, SEAT	1	1				
8	36P-24728-00	BRACKET, SEAT	1	1				
9	92012-06012	BOLT, BUTTON HEAD	2	2				
10	50W-24780-01	SEAT LOCK ASSY	1	1				
11	20S-24792-00	PLATE	1	1				
12	36P-2478X-00	BRACKET, SEAT LOCK	1	1				
13	95702-06500	NUT, FLANGE	2	2				
14	5JW-2478E-00	CABLE, SEAT LOCK	1	1				
15	2TV-W2470-00	ROTOR SET	1	1				
16	20S-2117K-00	STAY, LOCK	1	1				
17	90338-07043	PLUG	1	1				
18	90149-06081	SCREW	2	2				
19	36P-24710-00	SINGLE SEAT ASSY	1	1				
20	36P-2470F-00	.SEAT COVER COMP.	1	1				
21	36P-24718-00	.BRACKET, SEAT	1	1				
22	4D9-27114-00	.STOPPER, MAIN STAND	4	4				
23	2GH-24741-00	.PAD, SEAT	2	2				
24	90387-06091	.COLLAR	1	1				
25	90480-15M06	.GROMMET	1	1				
26	90105-06122	.BOLT, FLANGE	1	1				
27	90480-14016	.GROMMET	2	2				







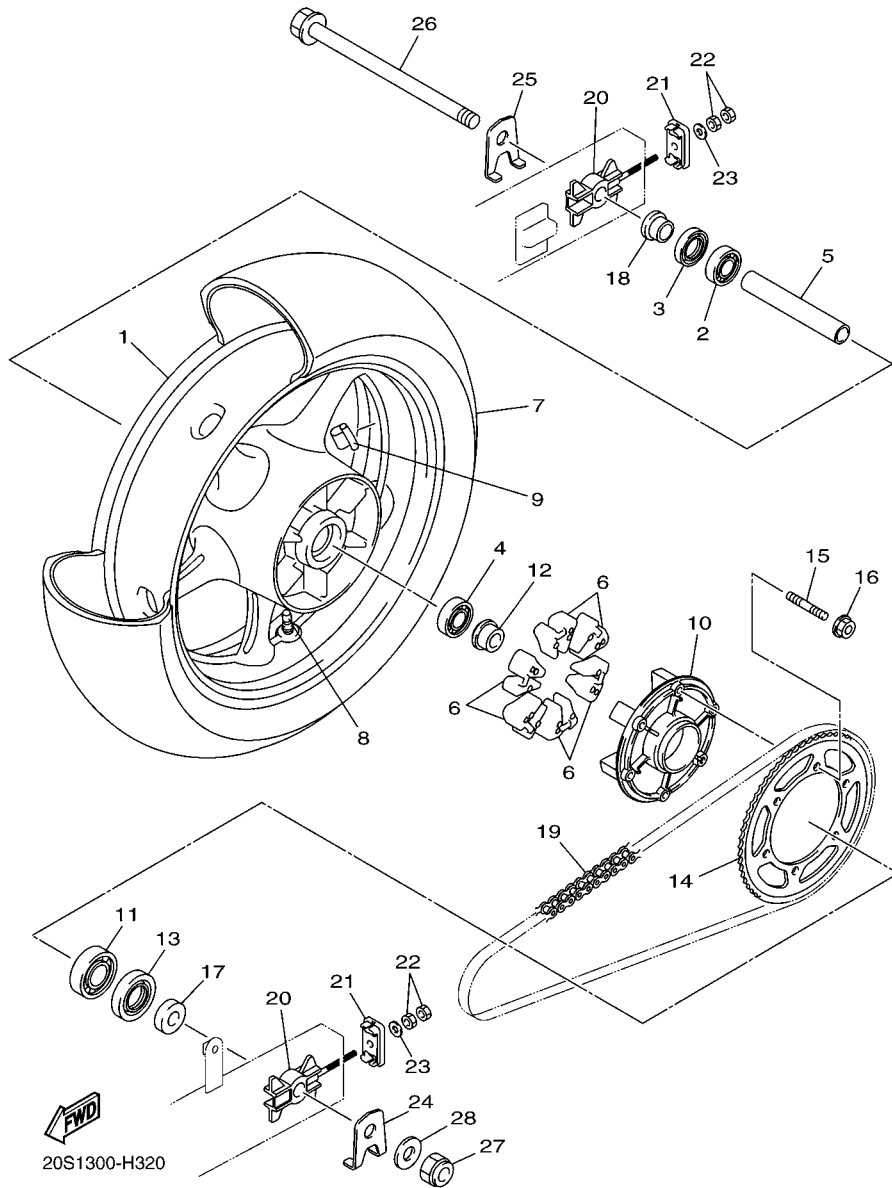
20S1300-H310

FIG. 30 FRONT BRAKE CALIPER

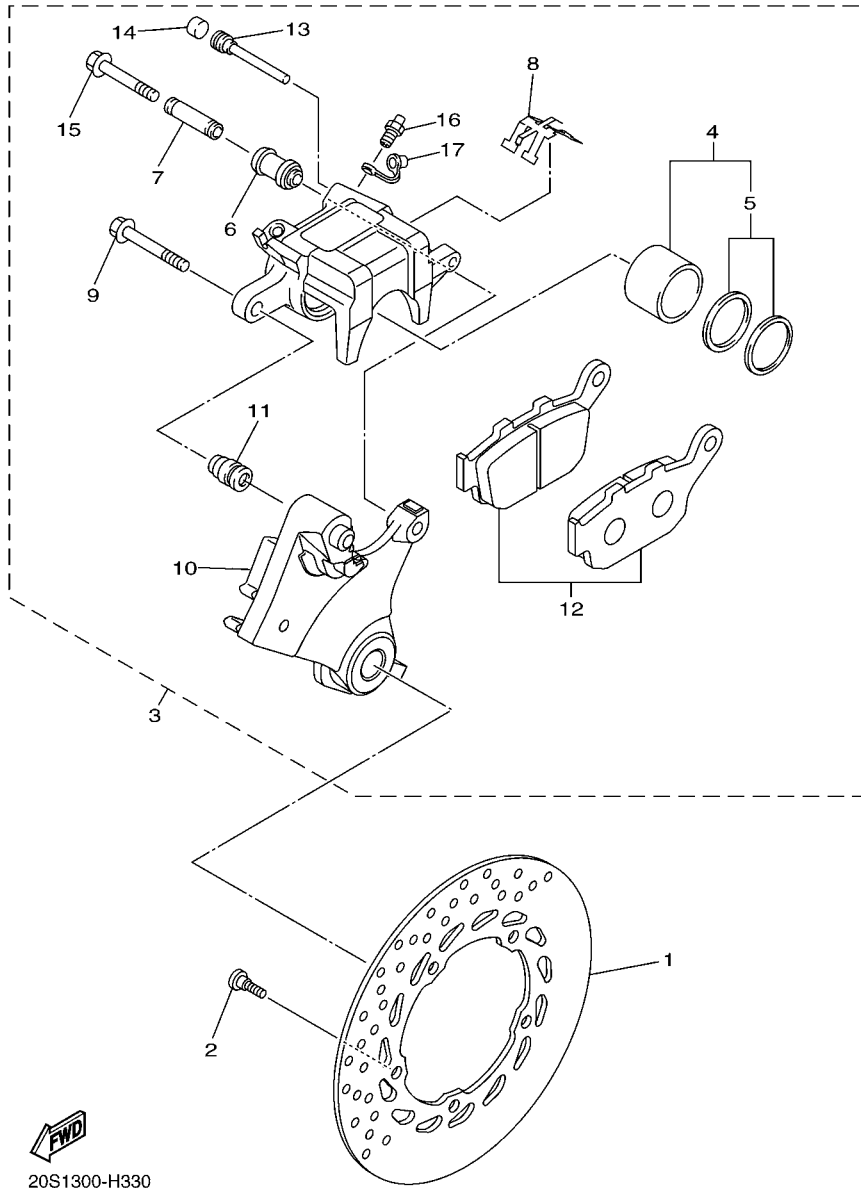
REF. NO.	PART NO.	DESCRIPTION	36P1	36P2	REMARKS
1	20S-2581T-00	DISK BRAKE ASSY	2	2	
2	90109-064G6	BOLT	10	10	
3	90105-10638	BOLT, FLANGE	2	2	
4	90105-10638	BOLT, FLANGE	2	2	
5	5VX-2580T-00	CALIPER ASSY (LEFT)	1	1	
6	5KS-W0057-00	.PISTON ASSY, CALIPER	1	1	
7	4FU-W0047-00	..CALIPER SEAL KIT	1	1	
8	5JW-25914-10	.PIN, SLIDE	2	2	
9	4TT-25937-00	.BOOT 2	2	2	
10	5VX-W0045-00	.BRAKE PAD KIT	1	1	
11	4BP-25919-00	.SUPPORT, PAD	2	2	
12	3YX-25929-00	.SPRING, ANTI RATTLE	1	1	
13	51L-W0048-00	.BLEED SCREW KIT	1	1	
14	5VX-2580U-00	CALIPER ASSY (RIGHT)	1	1	
15	5KS-W0057-00	.PISTON ASSY, CALIPER	1	1	
16	4FU-W0047-00	..CALIPER SEAL KIT	1	1	
17	5JW-25914-10	.PIN, SLIDE	2	2	
18	4TT-25937-00	.BOOT 2	2	2	
19	5VX-W0045-00	.BRAKE PAD KIT	1	1	
20	4BP-25919-00	.SUPPORT, PAD	2	2	
21	3YX-25929-00	.SPRING, ANTI RATTLE	1	1	
22	51L-W0048-00	.BLEED SCREW KIT	1	1	

FIG. 31 REAR WHEEL

REF. NO.	PART NO.	DESCRIPTION	36P1	36P2	REMARKS
1	20S-25338-00-98	CAST WHEEL, REAR	1	1	LGB
2	93306-30317	BEARING	1	1	
3	93102-25044	OIL SEAL	1	1	
4	93306-30317	BEARING	1	1	
5	20S-25317-00	SPACER, BEARING	1	1	
6	20S-25364-00	DAMPER	6	6	
7	L.M.	TIRE(160/60ZR17M/C 69W BT021R)	1		
8	93900-00030	VALVE, RIM (TR412)	1	1	TAIHEIYO
9	5MT-25398-00	BALANCER, WHEEL (10G)	1	1	UR
	5MT-25398-10	BALANCER, WHEEL (20G)	1	1	UR
	5MT-25398-20	BALANCER, WHEEL (30G)	1	1	UR
10	20S-25366-00	CLUTCH, HUB	1	1	
11	93306-20659	BEARING	1	1	
12	20S-25383-00	COLLAR, WHEEL	1	1	
13	93106-40041	OIL SEAL	1	1	
14	20S-25446-00	SPROCKET, DRIVEN (46T)	1	1	
15	90116-10048	BOLT, STUD	6	6	
16	95602-10200	NUT, U FLANGE	6	6	
17	20S-25377-00	COLLAR, WHEEL	1	1	
18	20S-25183-00	COLLAR, WHEEL	1	1	
19	94582-24118	CHAIN (DID520VP2)	1	1	
20	1UF-25388-01	PULLER, CHAIN 1	2	2	
21	1UF-22174-01	END 1	2	2	
22	95302-08600	NUT	4	4	
23	92902-08600	WASHER, PLATE	2	2	
24	1UF-2533A-01	PLATE, INDICATOR	1	1	



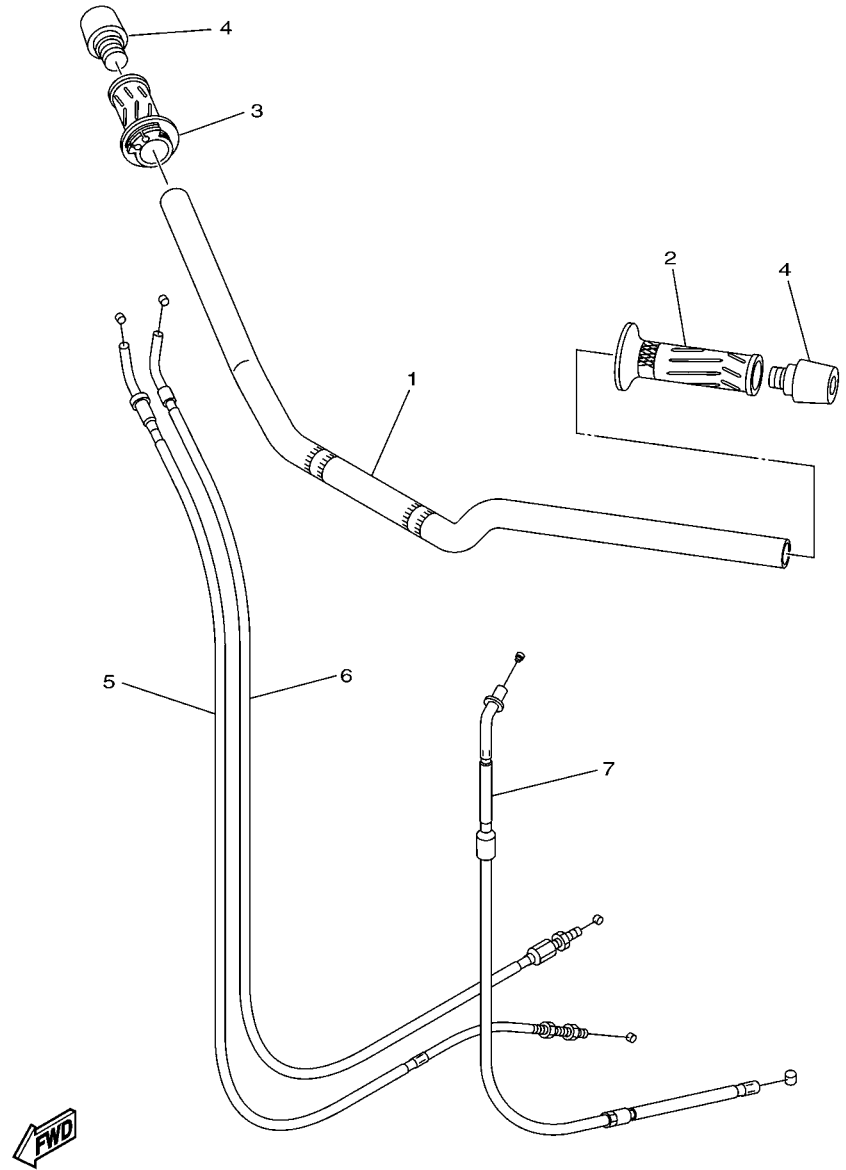




20S1300-H330

FIG. 32 REAR BRAKE CALIPER

REF. NO.	PART NO.	DESCRIPTION	36P1	36P2	REMARKS
1	20S-2582W-00	DISK, REAR BRAKE 2	1	1	
2	90109-083G4	BOLT	5	5	
3	20S-2580W-00	CALIPER ASSY, REAR 2	1	1	
4	5SL-W0057-00	.PISTON ASSY, CALIPER	1	1	
5	5SL-W0047-00	..CALIPER SEAL KIT	1	1	
6	5SL-25917-00	.BOOT, CALIPER	1	1	
7	5SL-25838-00	.SLEEVE, CALIPER	1	1	
8	5SL-25919-00	.SUPPORT, PAD	1	1	
9	5SL-25914-00	.PIN, SLIDE	1	1	
10	20S-25921-50	.BRACKET, SUPPORT	1	1	
11	3JD-25917-00	.BOOT, CALIPER	1	1	
12	20S-W0046-00	.BRAKE PAD KIT 2	1	1	
13	8CR-25924-00	.PIN, PAD	1	1	
14	5DH-25916-00	.PLUG	1	1	
15	5SL-25926-00	.BOLT	1	1	
16	1UY-25824-51	.SCREW, BLEED	1	1	
17	1UY-25825-51	.CAP	1	1	



36P1110-H330

FIG. 33 STEERING HANDLE & CABLE

REF. NO.	PART NO.	DESCRIPTION	36P1	36P2			REMARKS
1	20S-26111-00	HANDLEBAR	1	1			
2	4YR-26241-02	GRIP (LEFT)	1	1			
3	4YR-26240-02	GRIP ASSY	1	1			
4	51J-26246-01	END, GRIP	2	2			
5	36P-26311-00	CABLE, THROTTLE 1	1	1			
6	36P-26312-00	CABLE, THROTTLE 2	1	1			
7	20S-26335-00	CABLE, CLUTCH	1	1			



20S1300-H350

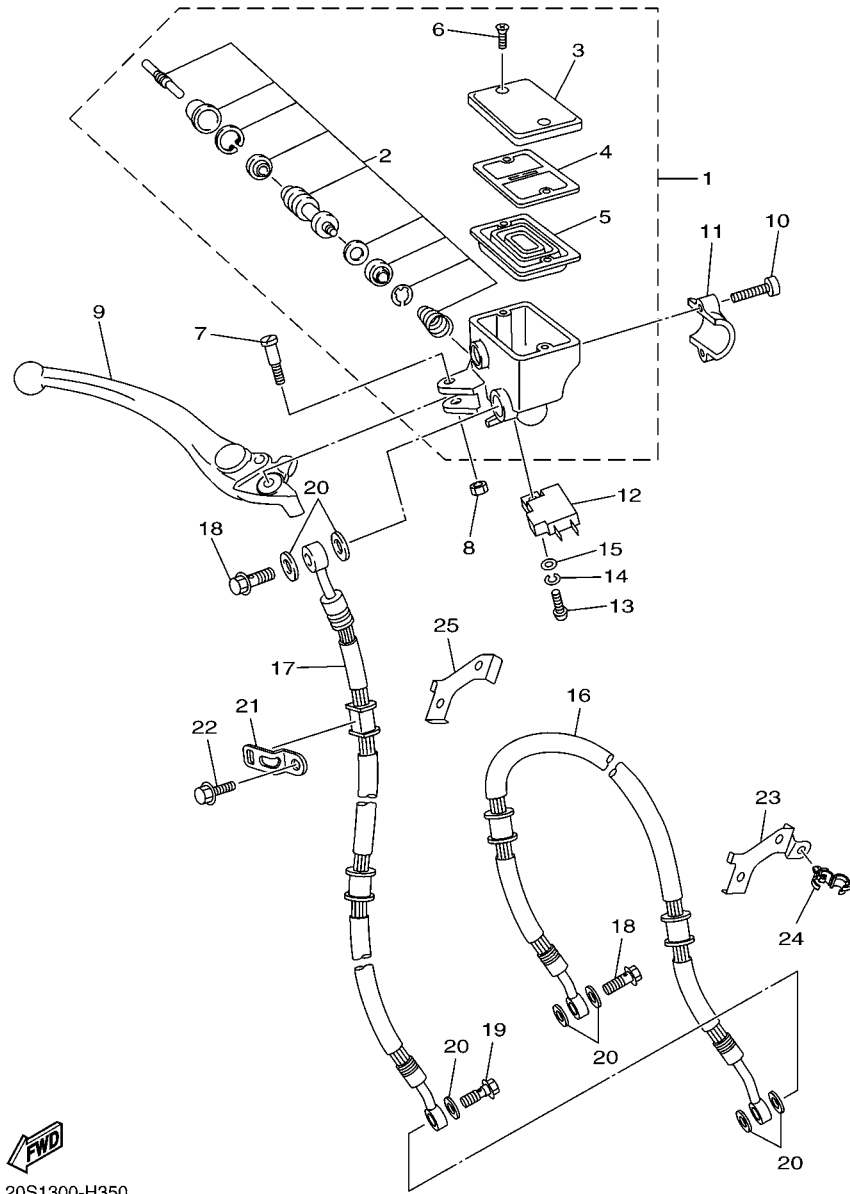
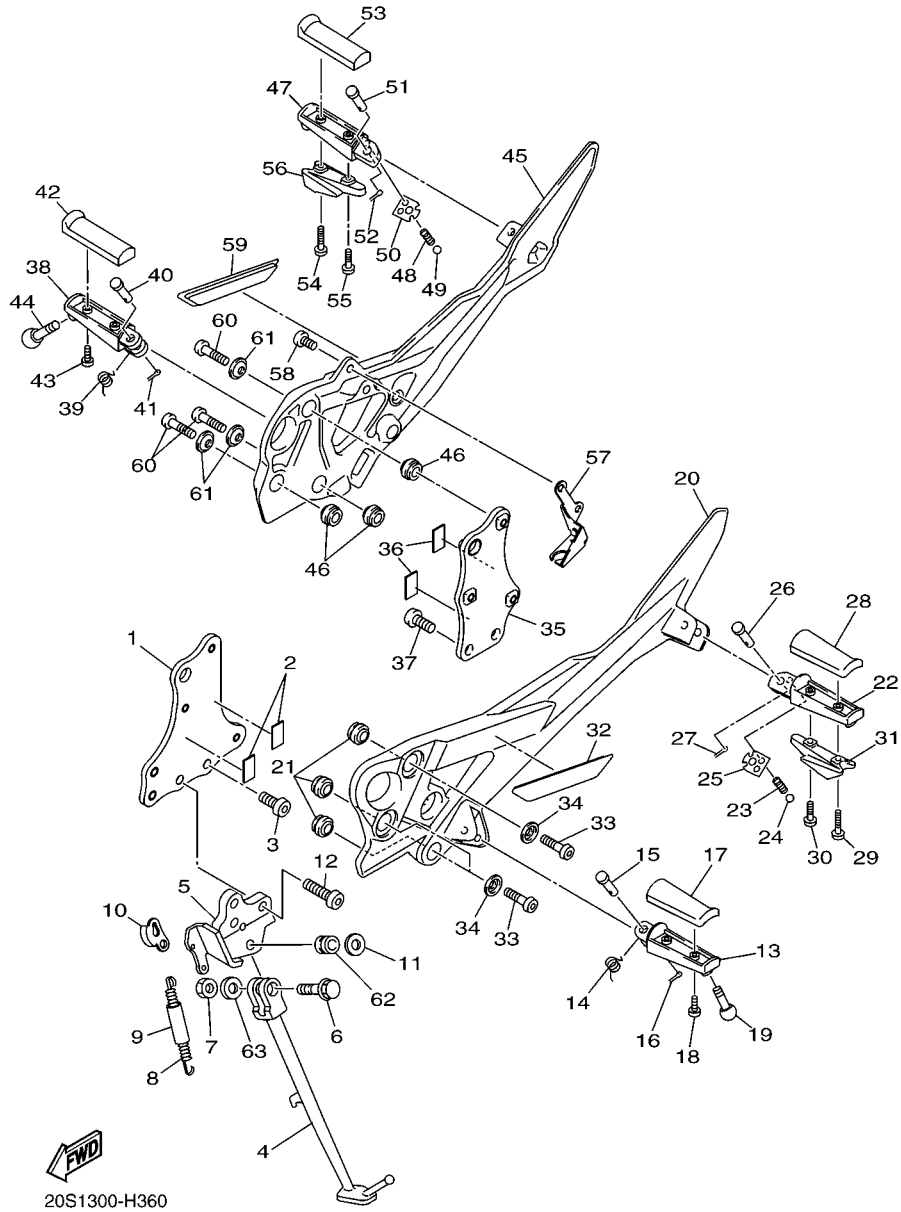


FIG. 34 FRONT MASTER CYLINDER

REF. NO.	PART NO.	DESCRIPTION	36P1	36P2	REMARKS
1	36C-W2587-00	MASTER CYLINDER SUB ASSY	1	1	
2	2D1-W0041-00	.CYLINDER KIT, MASTER	1	1	
3	5VS-25852-00	.CAP, RESERVOIR	1	1	
4	5VS-25855-00	.BUSH,DIAPHRAGM	1	1	
5	20S-25854-00	.GASKET, DIAPHRAGM	1	1	
6	5VS-2589H-00	.SCREW	2	2	
7	5VS-2589F-00	BOLT, LEVER	1	1	
8	95617-06100	NUT, U	1	1	
9	5VS-83922-00	LEVER 2	1	1	
10	5VS-26332-00	BOLT	2	2	
11	5VS-25867-00	BRACKET, MASTER CYLINDER	1	1	
12	4HM-83980-00	FRONT STOP SWITCH ASSY	1	1	
13	98502-04012	SCREW, PAN HEAD	1	1	
14	92902-04100	WASHER, SPRING	1	1	
15	92902-04600	WASHER, PLATE	1	1	
16	20S-25872-00	HOSE, BRAKE 1	1	1	
17	20S-25873-00	HOSE, BRAKE 2	1	1	
18	90401-10020	BOLT, UNION	2	2	
19	90401-10038	BOLT, UNION	1	1	
20	90430-10005	GASKET	7	7	
21	5SL-25876-00	HOLDER, BRAKE HOSE 2	1	1	
22	95802-06012	BOLT, FLANGE	1	1	
23	20S-2537W-00	BRACKET 1	1	1	
24	90464-18002	CLAMP	3	3	
25	20S-25876-00	HOLDER, BRAKE HOSE 2	1	1	

FIG. 35 STAND & FOOTREST

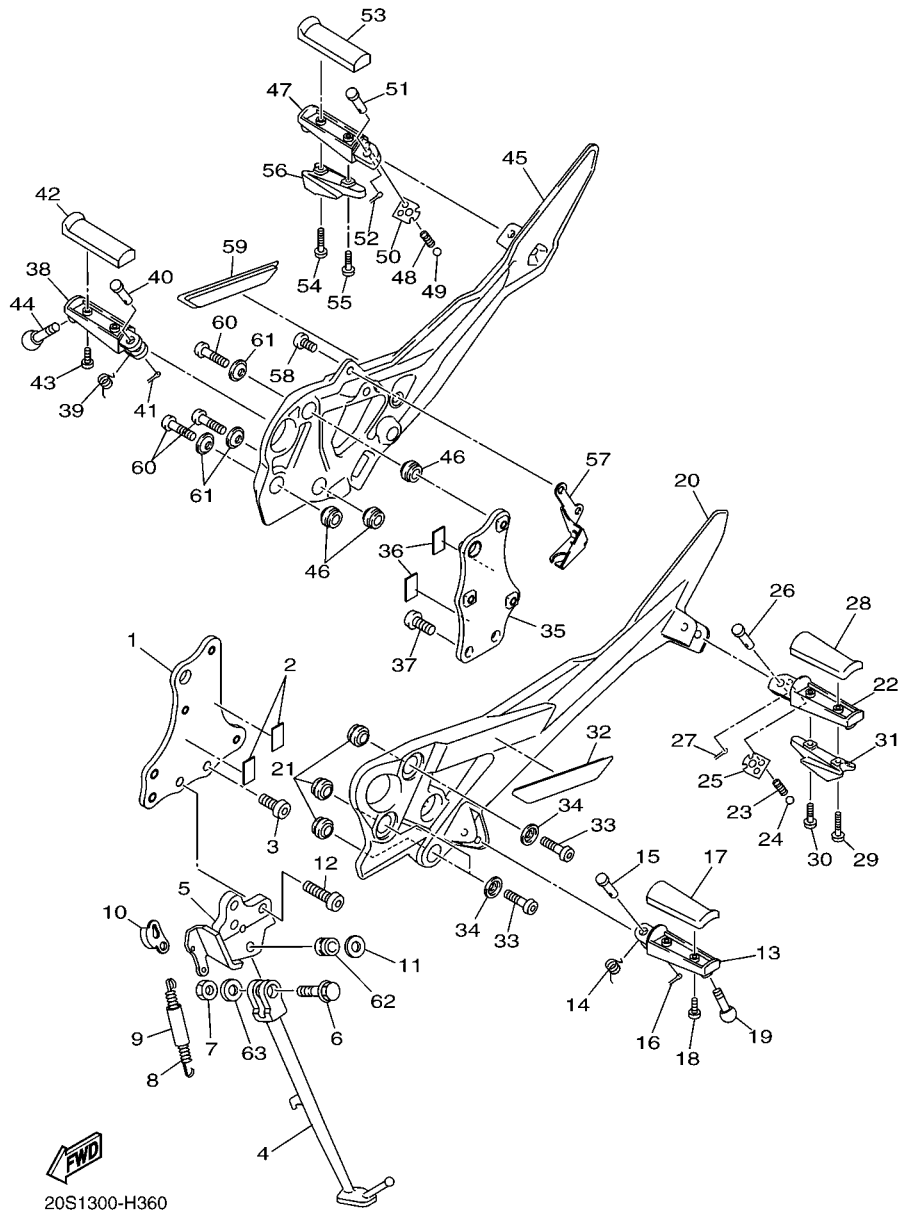
REF. NO.	PART NO.	DESCRIPTION	36P1	36P2	REMARKS
1	20S-274A3-00	BEACKET, ADAPTER 1	1	1	
2	4RR-21485-00	DAMPER, RUBBER 1	2	2	
3	90111-10043	BOLT, HEX. SOCKET BUTTON	1	1	
4	20S-27311-00	STAND, SIDE	1	1	
5	20S-27321-00	BRACKET, SIDE STAND	1	1	
6	90105-10365	BOLT, FLANGE	1	1	
7	90185-10023	NUT, SELF-LOCKING	1	1	
8	90506-23018	SPRING, TENSION	1	1	
9	5VX-27351-00	GUIDE, SIDE STAND	1	1	
10	5VX-27315-00	LINK, SIDE STAND	1	1	
11	90201-10051	WASHER, PLATE	1	1	
12	90111-10045	BOLT, HEX. SOCKET BUTTON	3	3	
13	4BH-27451-01	FOOTREST	1	1	
14	90508-20572	SPRING, TORSION	1	1	
15	91701-08042	PIN	1	1	
16	91402-25015	PIN, COTTER	1	1	
17	4BP-27413-00	COVER, FOOTREST	1	1	
18	90157-05025	SCREW, PAN HEAD	2	2	
19	90109-08203	BOLT	1	1	
20	20S-27442-00	BRACKET 2	1	1	
21	5VX-27424-00	DAMPNER, FOOTREST 2	3	3	
22	5RT-27431-00	FOOTREST, REAR 1	1	1	
23	90501-12743	SPRING, COMPRESSION	1	1	
24	93501-04011	BALL	1	1	
25	5VX-27437-00	WASHER, SPECIAL	1	1	
26	91701-08042	PIN	1	1	
27	91402-25015	PIN, COTTER	1	1	



20S1300-H360

FIG. 35 STAND & FOOTREST

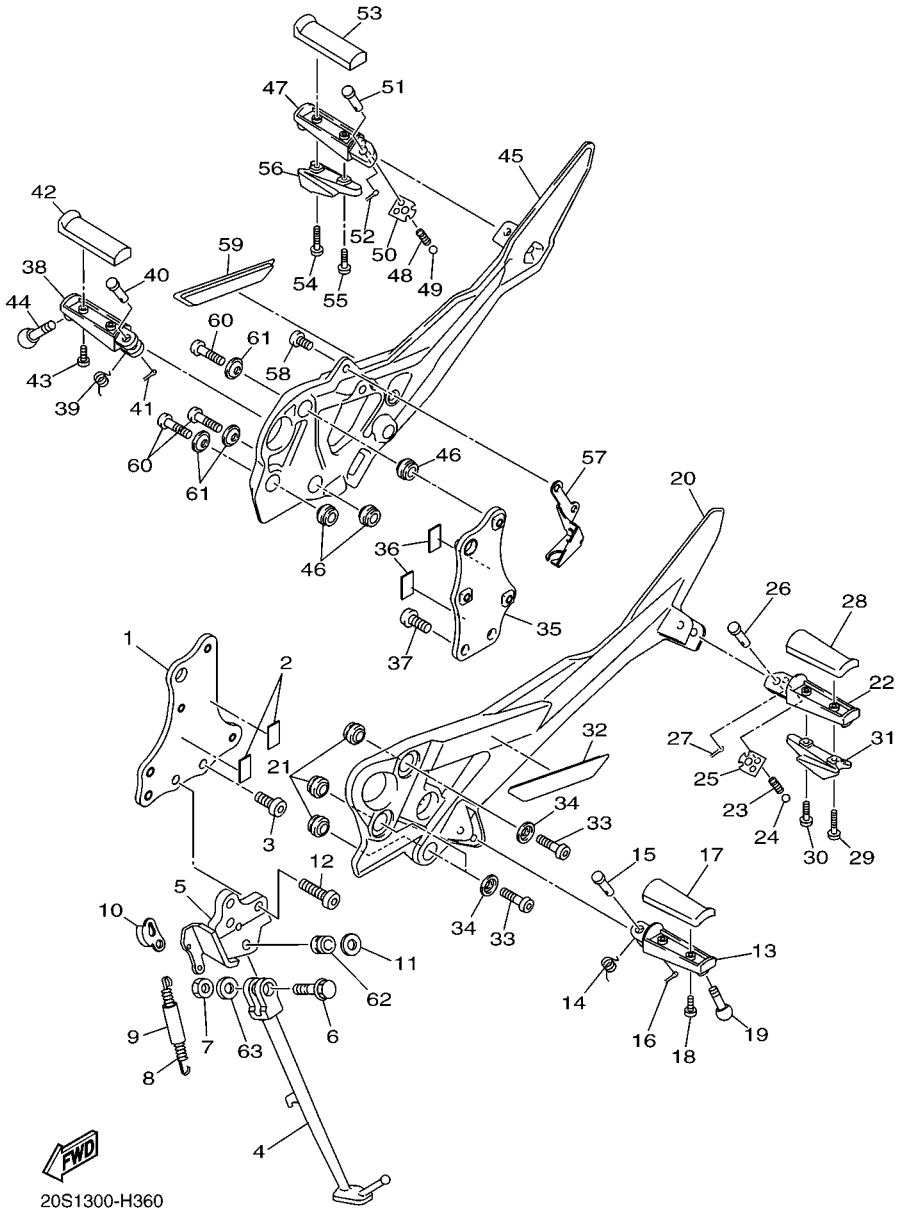
REF. NO.	PART NO.	DESCRIPTION			REMARKS
			36P1	36P2	
28	4BP-27413-00	COVER, FOOTREST	1	1	
29	90159-05187	SCREW, WITH WASHER	1	1	
30	90159-05004	SCREW, WITH WASHER	1	1	
31	5LV-2741E-01	ARM 2	1	1	
32	20S-27453-00	COVER 1	1	1	
33	90111-08066	BOLT,HEX. SOCKET BUTTON	3	3	
34	90209-08295	WASHER	3	3	
35	20S-274A4-00	BRACKET,ADAPTER 2	1	1	
36	4RR-21485-00	DAMPER, RUBBER 1	2	2	
37	90111-10036	BOLT,HEX. SOCKET BUTTON	2	2	
38	4BH-27461-01	FOOTREST	1	1	
39	90508-20572	SPRING, TORSION	1	1	
40	91701-08042	PIN	1	1	
41	91402-25015	PIN, COTTER	1	1	
42	4BP-27413-00	COVER, FOOTREST	1	1	
43	90157-05025	SCREW, PAN HEAD	2	2	
44	90109-08203	BOLT	1	1	
45	20S-27443-00	BRACKET 3	1	1	
46	5VX-27424-00	DAMPER, FOOTREST 2	3	3	
47	5RT-27441-00	FOOTREST, REAR 2	1	1	
48	90501-12743	SPRING, COMPRESSION	1	1	
49	93501-04011	BALL	1	1	
50	5VX-27437-00	WASHER, SPECIAL	1	1	
51	91701-08042	PIN	1	1	
52	91402-25015	PIN, COTTER	1	1	
53	4BP-27413-00	COVER, FOOTREST	1	1	
54	90159-05187	SCREW, WITH WASHER	1	1	



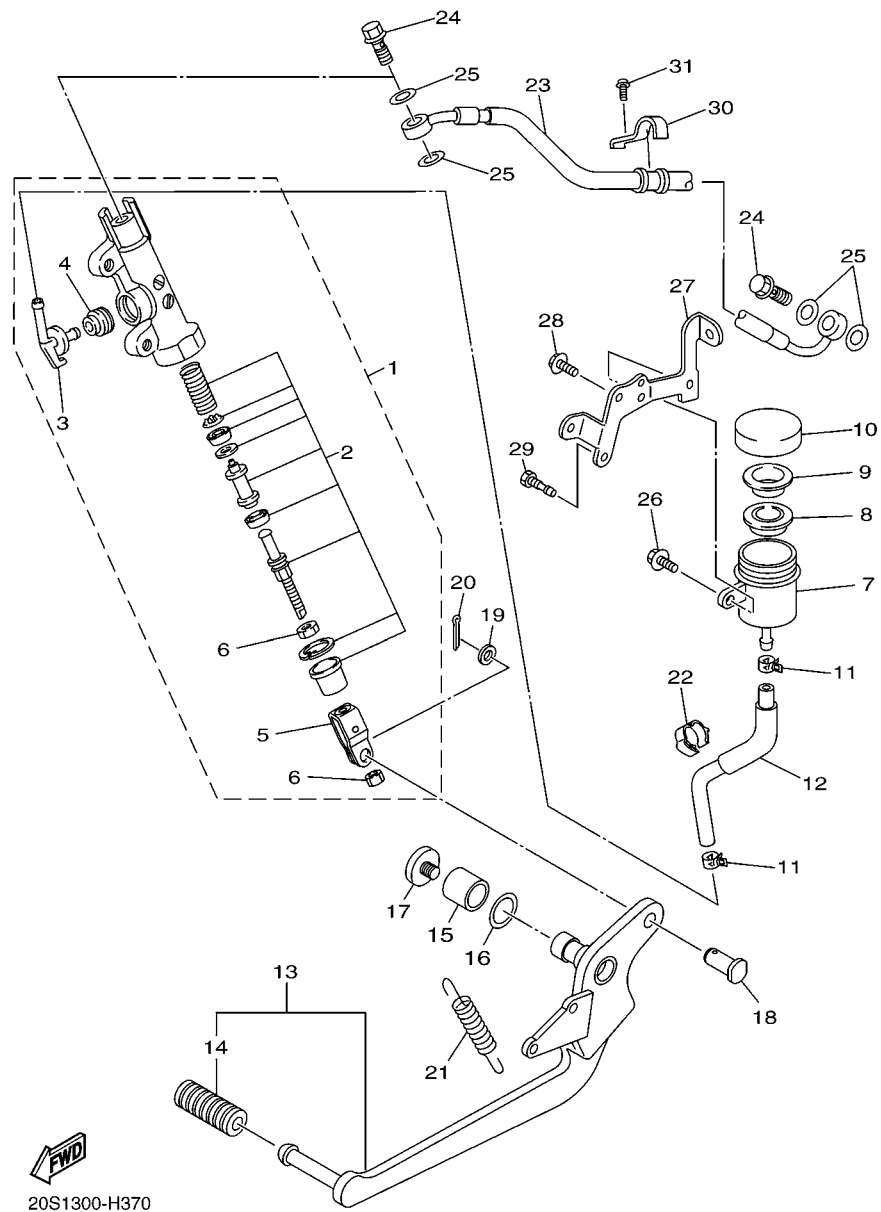
20S1300-H360

**FIG. 35 STAND & FOOTREST**

REF. NO.	PART NO.	DESCRIPTION			REMARKS
			36P1	36P2	
55	90159-05004	SCREW, WITH WASHER	1	1	
56	5LV-2741E-01	ARM 2	1	1	
57	20S-2144G-00	STAY, STOP SWITCH	1	1	
58	92014-08020	BOLT, BUTTON HEAD	2	2	
59	20S-27463-00	COVER 2	1	1	
60	90111-08066	BOLT, HEX. SOCKET BUTTON	3	3	
61	90209-08295	WASHER	3	3	
62	90387-1003G	COLLAR	1	1	
63	90201-10035	WASHER, PLATE	1	1	
-----					
-----					
-----					
-----					
-----					
-----					
-----					
-----					
-----					
-----					





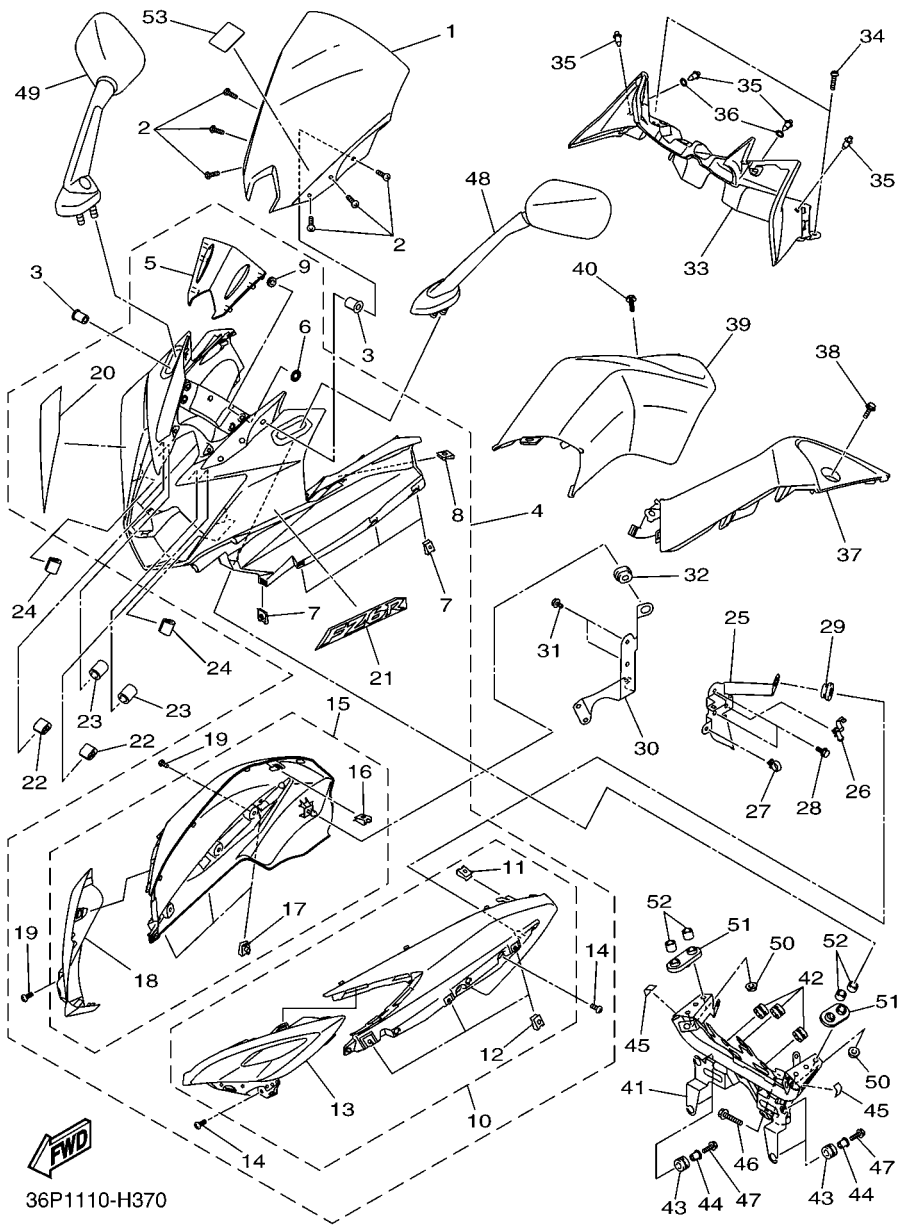


**FIG. 36 REAR MASTER CYLINDER**

REF. NO.	PART NO.	DESCRIPTION	36P1	36P2	REMARKS
28	95802-06012	BOLT, FLANGE	1	1	
29	90153-06034	SCREW, HEXAGON	1	1	
30	20S-2587A-00	HOLDER, BRAKE HOSE	1	1	
31	95022-06012	BOLT, FLANGE	1	1	

FIG. 37 COWLING 1

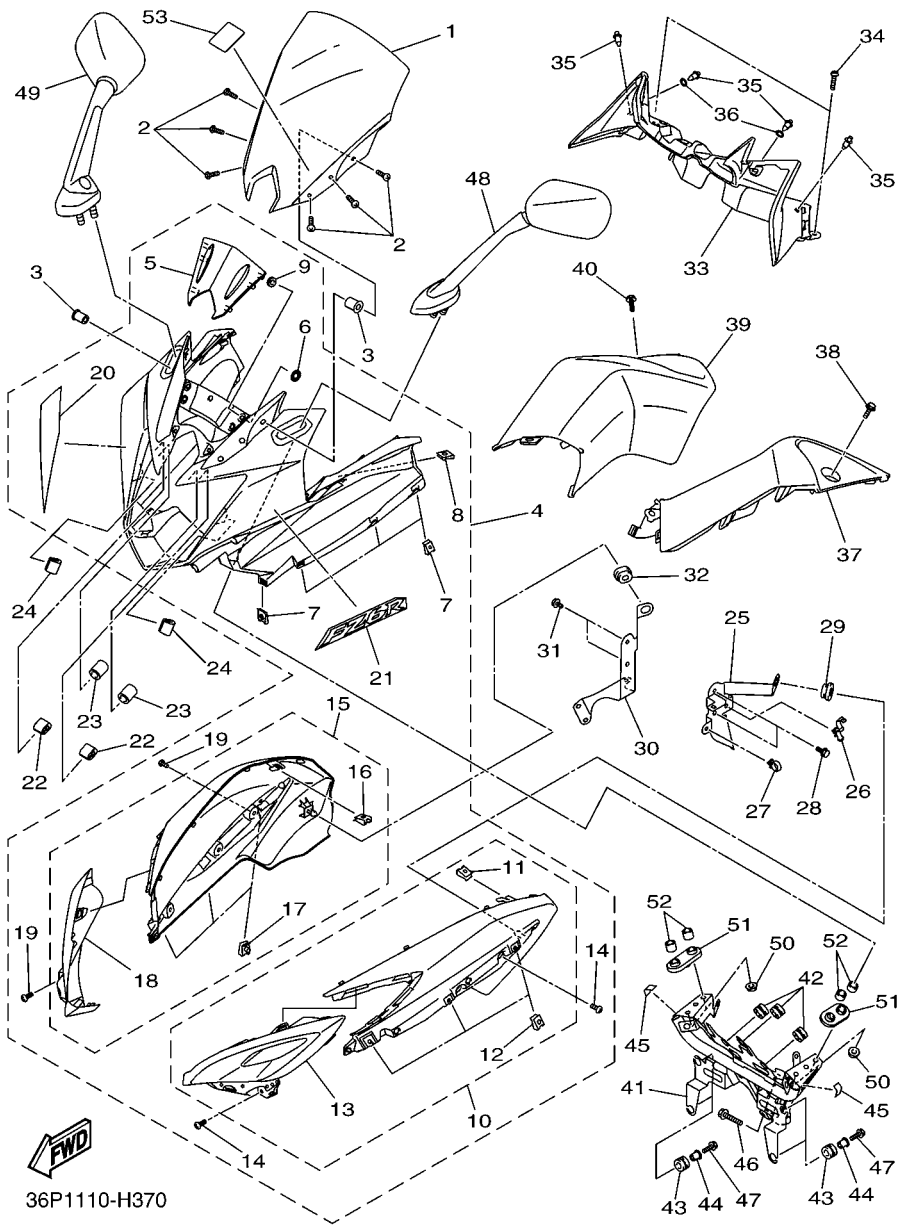
REF. NO.	PART NO.	DESCRIPTION	36P1	36P2	REMARKS
1	36P-28381-00	WINDSHIELD	1	1	
2	90150-05023	SCREW, ROUND HEAD	6	6	
3	90179-05523	NUT	6	6	
4	36P-Y283G-00-P1	BODY, FRONT UPPER 1	1		FOR SMX
5	36P-83559-00	.COVER, METER	1	1	
6	90183-05M02	..NUT, SPRING	4	4	
7	90183-05042	..NUT, SPRING	8	8	
8	90183-05076	..NUT, SPRING	2	2	
9	5SL-84753-00	..DAMPER	4	4	
10	36P-2830N-00	..BOX SUB ASSY	1	1	
11	90183-05076	..NUT, SPRING	1	1	
12	90183-05008	..NUT, SPRING	3	3	
13	36P-2837N-00	..GRILL, AIR INTAKE 1	1	1	
14	97702-50016	..SCREW, TAPPING	4	4	
15	36P-2830R-00	..BOX SUB ASSY	1	1	
16	90183-05076	..NUT, SPRING	1	1	
17	90183-05008	..NUT, SPRING	3	3	
18	36P-2837R-00	..GRILL, AIR INTAKE 2	1	1	
19	97702-50016	..SCREW, TAPPING	4	4	
20	N/A				
21	N/A				
22	20S-28376-00	TRIM	2	2	
23	90445-05003	HOSE	2	2	
24	1FK-2171M-00	MOLE, SIDE COVER 2	2	2	
25	36P-2172R-00	BRACKET 5	1	1	
26	90464-16006	CLAMP	1	1	



36P1110-H370

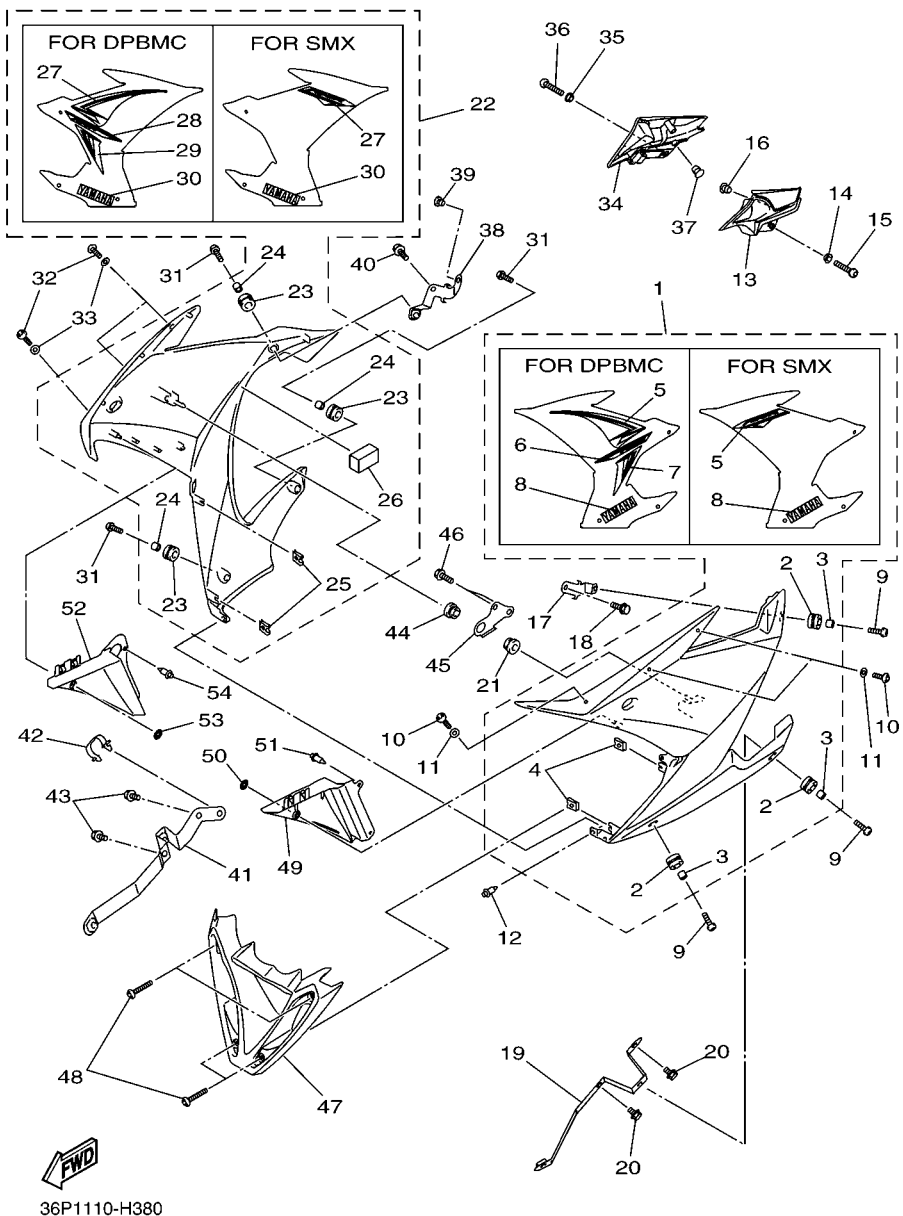
FIG. 37 COWLING 1

REF. NO.	PART NO.	DESCRIPTION			REMARKS
			36P1	36P2	
27	90464-15157	CLAMP	1	1	
28	95802-06012	BOLT, FLANGE	2	2	
29	90480-01558	GROMMET	1	1	
30	36P-2172T-00	BRKT 6	1	1	
31	95802-06012	BOLT, FLANGE	2	2	
32	90480-01558	GROMMET	1	1	
33	36P-2836K-00	PANEL, INNER 1	1	1	
34	90111-05034	BOLT,HEX. SOCKET BUTTON	2	2	
35	90269-06008	RIVET	4	4	
36	90202-06004	WASHER, PLATE	2	2	
37	36P-2836L-00	PANEL, INNER 2	1	1	
38	90111-05034	BOLT,HEX. SOCKET BUTTON	1	1	
39	36P-2836M-00	PANEL, INNER 3	1	1	
40	90111-05034	BOLT,HEX. SOCKET BUTTON	1	1	
41	36P-28356-00	STAY 1	1	1	
42	3C3-83513-00	DAMPER	3	3	
43	90480-14004	GROMMET	4	4	
44	90387-07391	COLLAR	4	4	
45	36P-2837J-00	DAMPER 5	2	2	
46	95822-08035	BOLT, FLANGE	2	2	
47	95822-06025	BOLT, FLANGE	4	4	
48	36P-26280-00	REAR VIEW MIRROR ASSY (LEFT)	1	1	
49	36P-26290-00	REAR VIEW MIRROR ASSY (RIGHT)	1	1	
50	95702-06500	NUT, FLANGE	4	4	
51	3C3-26298-00	PLATE, MIRROR FITTING 1	2	2	
52	90387-064T3	COLLAR	4	4	
53	4B5-2815K-00	LABEL, NOTICE WINDSHIELD 1	1	1	



36P1110-H370

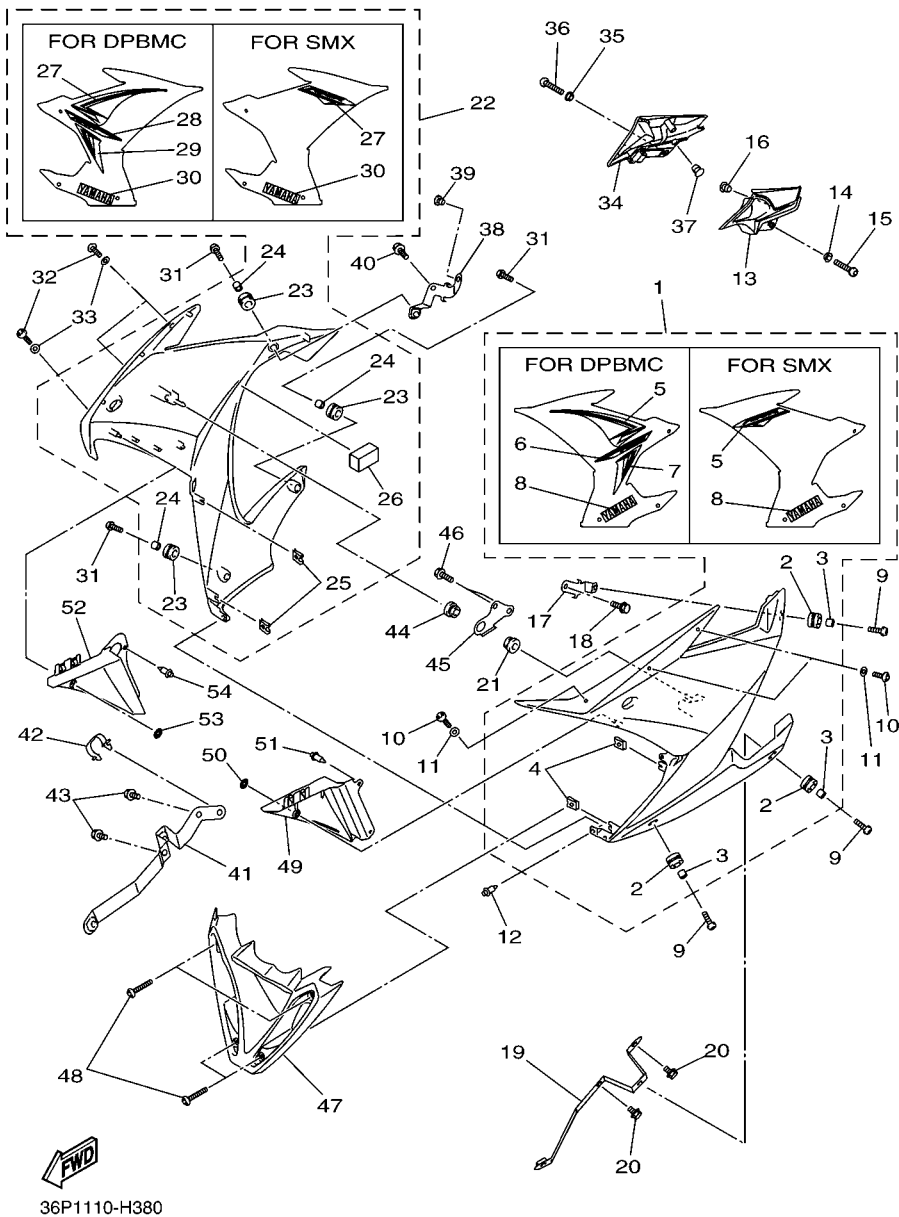
FIG. 38 COWLING 2



36P1110-H380

REF. NO.	PART NO.	DESCRIPTION	36P1	36P2	REMARKS
1	36P-Y283U-00-P1	PANEL ASSEMBLY 1	1		FOR SMX
2	90480-14003	.GROMMET	3	3	
3	90387-06057	.COLLAR	3	3	
4	90183-05076	.NUT, SPRING	2	2	
5	36P-2839E-00	.GRAPHIC, 1	1		FOR SMX
6	N/A				
7	N/A				
8	36P-2153E-10	.EMBLEM, YAMAHA	1		FOR SMX
9	90149-06302	SCREW	3	3	
10	90111-05007	BOLT, HEX. SOCKET BUTTON	3	3	
11	90202-05180	WASHER, PLATE	3	3	
12	90269-06008	RIVET	1	1	
13	36P-2171N-00	MOLE, SIDE COVER 3	1	1	
14	90387-06130	COLLAR	1	1	
15	90149-06302	SCREW	1	1	
16	90338-07043	PLUG	1	1	
17	36P-2833A-00	BRACKET 7	1	1	
18	95802-06014	BOLT, FLANGE	1	1	
19	36P-2836A-00	BRACKET 1	1	1	
20	90109-060E9	BOLT	2	2	
21	90480-01558	GROMMET	1	1	
22	36P-Y283V-00-P1	PANEL ASSEMBLY 2	1		FOR SMX
23	90480-14003	.GROMMET	3	3	

FIG. 38 COWLING 2

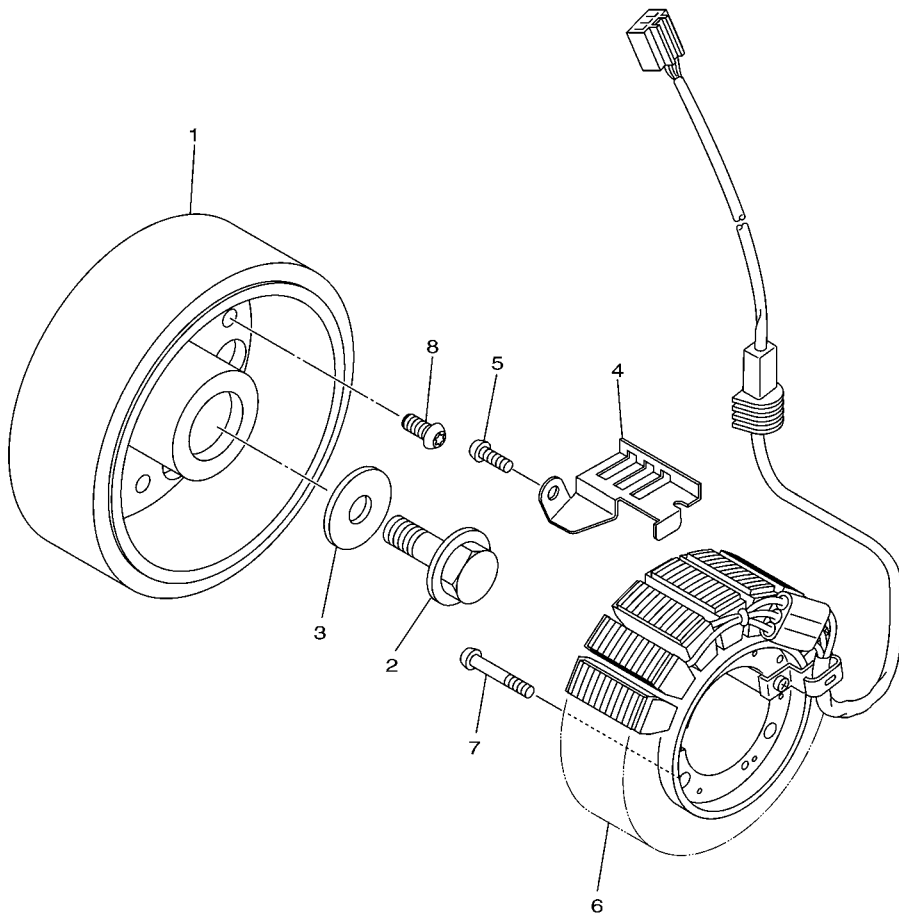


REF. NO.	PART NO.	DESCRIPTION	36P1	36P2	REMARKS
24	90387-06057	.COLLAR	3	3	
25	90183-05076	.NUT, SPRING	2	2	
26	2C0-2162G-00	.PLATE 1	1	1	
27	36P-2839F-00	.GRAPHIC, 2	1		FOR SMX
28	N/A				
29	N/A				
30	36P-2153E-10	.EMBLEM, YAMAHA	1		FOR SMX
31	90149-06302	SCREW	3	3	
32	90111-05007	BOLT, HEX. SOCKET BUTTON	3	3	
33	90202-05180	WASHER, PLATE	3	3	
34	36P-2171R-00	MOLE, SIDE COVER 4	1	1	
35	90387-06130	COLLAR	1	1	
36	90149-06302	SCREW	1	1	
37	90338-07043	PLUG	1	1	
38	36P-2833E-00	BRACKET 8	1	1	
39	90338-07157	PLUG	1	1	
40	95802-06014	BOLT, FLANGE	1	1	
41	36P-2836E-00	BRACKET 2	1	1	
42	90464-24230	CLAMP	1	1	
43	90109-060E9	BOLT	2	2	
44	90480-01558	GROMMET	1	1	
45	20S-21843-00	STAY, 4	1	1	
46	95822-06014	BOLT, FLANGE	2	2	
47	36P-22863-00	COVER, UNDER	1	1	
48	90111-05034	BOLT, HEX. SOCKET BUTTON	4	4	

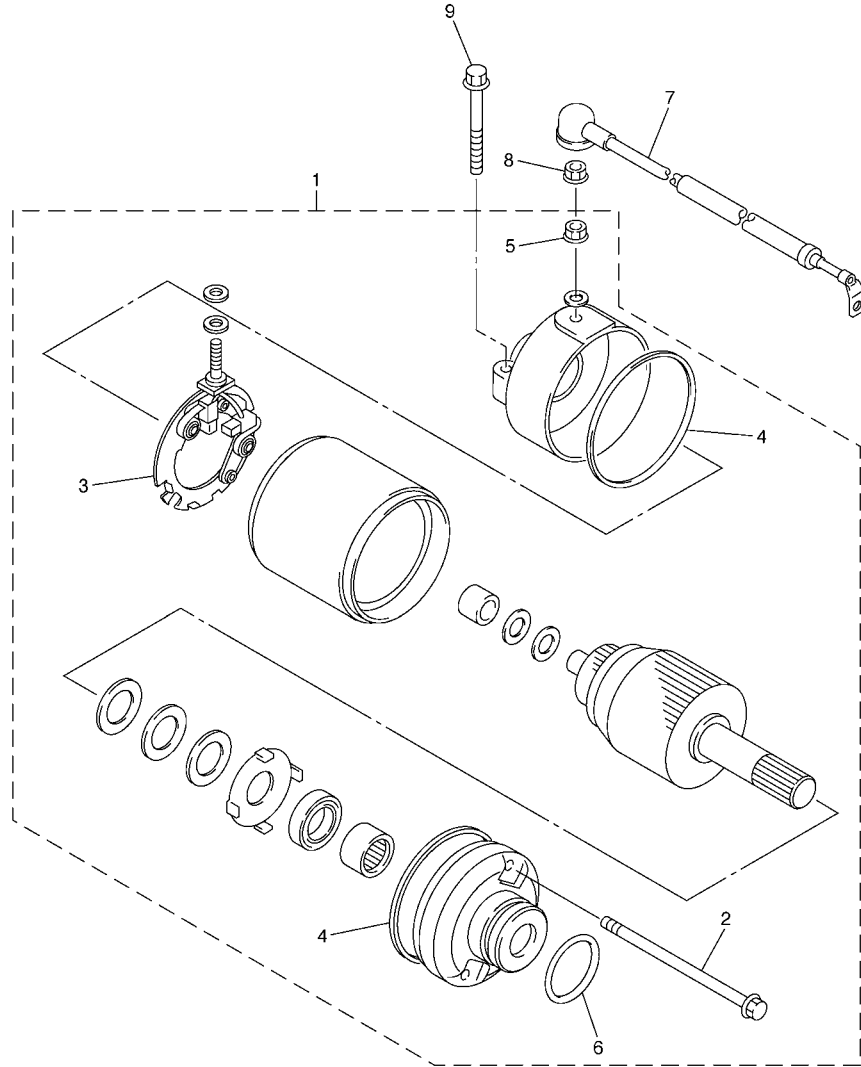


**FIG. 39 GENERATOR**

REF. NO.	PART NO.	DESCRIPTION	36P1	36P2			REMARKS
1	5VX-81450-00	ROTOR ASSY	1	1			
2	90105-126A8	BOLT, FLANGE	1	1			
3	90201-12008	WASHER, PLATE	1	1			
4	5VX-15484-00	CLAMP 2	1	1			
5	90149-06071	SCREW	1	1			
6	20S-81410-00	STATOR ASSY	1	1			
7	90149-06093	SCREW	3	3			
8	90149-08030	SCREW	3	3			
-----							
-----							
-----							
-----							
-----							
-----							



  
20S1300-H380



**FIG. 40 STARTING MOTOR**

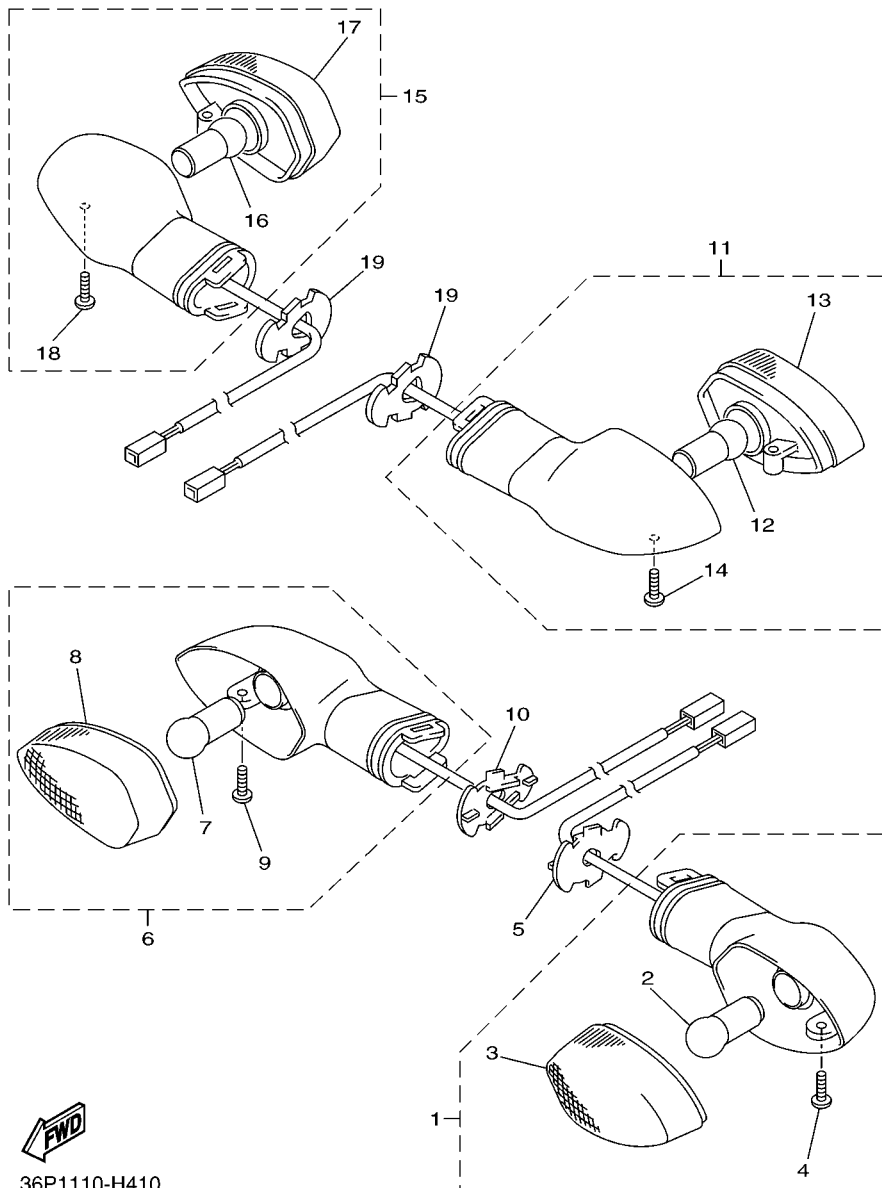
REF. NO.	PART NO.	DESCRIPTION	36P1	36P2				REMARKS
1	2C0-81890-00	MOTOR ASSY	1	1				
2	4WP-81826-00	.BOLT	2	2				
3	4WP-81801-00	.BRUSH SET	1	1				
4	4WP-81844-00	.GASKET	2	2				
5	4XV-8182A-00	.NUT	1	1				
6	1FK-81847-00	.O-RING	1	1				
7	5VX-81815-00	CORD, STARTER MOTOR	1	1				
8	4XV-8182A-00	NUT	1	1				
9	95022-06025	BOLT, FLANGE	2	2				



2C01300-E400

FIG. 41 FLASHER LIGHT

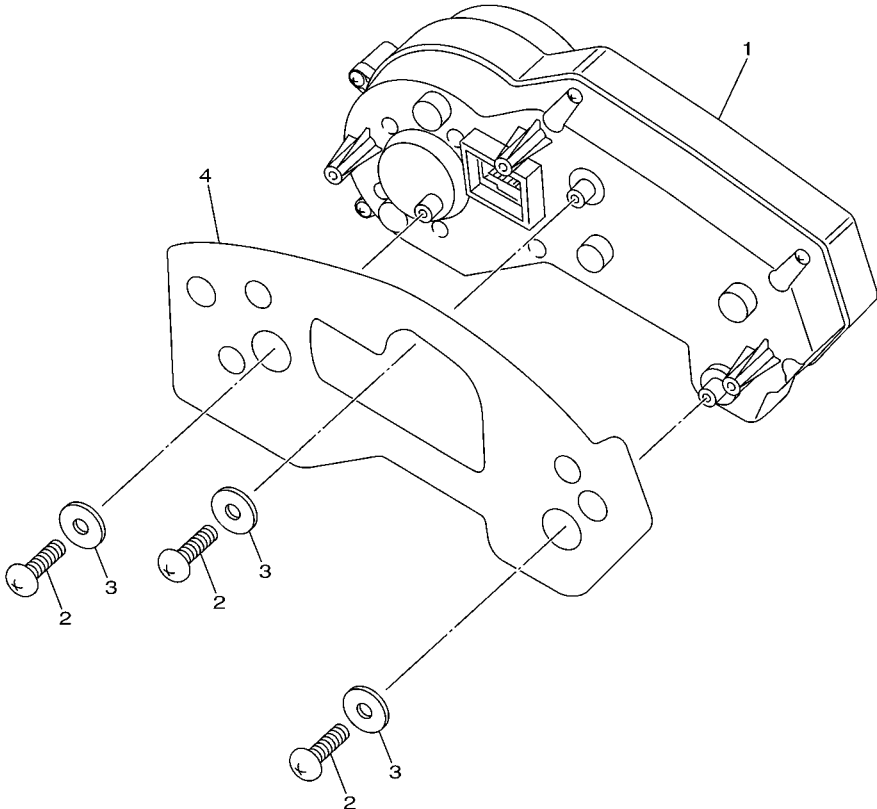
REF. NO.	PART NO.	DESCRIPTION	36P1	36P2			REMARKS
1	2C0-83310-10	FRONT FLASHER LIGHT ASSY 1	1	1			
2	1A2-84714-41	.BULB (12V-21/5W)	1	1			
3	2C0-8333A-10	.LENS COMP	1	1			
4	97702-40010	.SCREW, TAPPING	1	1			
5	2C0-83318-00	STAY, FLASHER 1	1	1			
6	2C0-83320-10	FRONT FLASHER LIGHT ASSY 2	1	1			
7	1A2-84714-41	.BULB (12V-21/5W)	1	1			
8	2C0-8334A-10	.LENS COMP	1	1			
9	97702-40010	.SCREW, TAPPING	1	1			
10	2C0-83318-00	STAY, FLASHER 1	1	1			
11	2C0-83330-10	REAR FLASHER LIGHT ASSY 1	1	1			
12	306-83311-40	.BULB, FLASHER (12V-21W)	1	1			
13	2C0-8334A-10	.LENS COMP	1	1			
14	97702-40010	.SCREW, TAPPING	1	1			
15	2C0-83340-10	REAR FLASHER LIGHT ASSY 2	1	1			
16	306-83311-40	.BULB, FLASHER (12V-21W)	1	1			
17	2C0-8333A-10	.LENS COMP	1	1			
18	97702-40010	.SCREW, TAPPING	1	1			
19	3D7-83318-10	STAY, FLASHER 1	2	2			



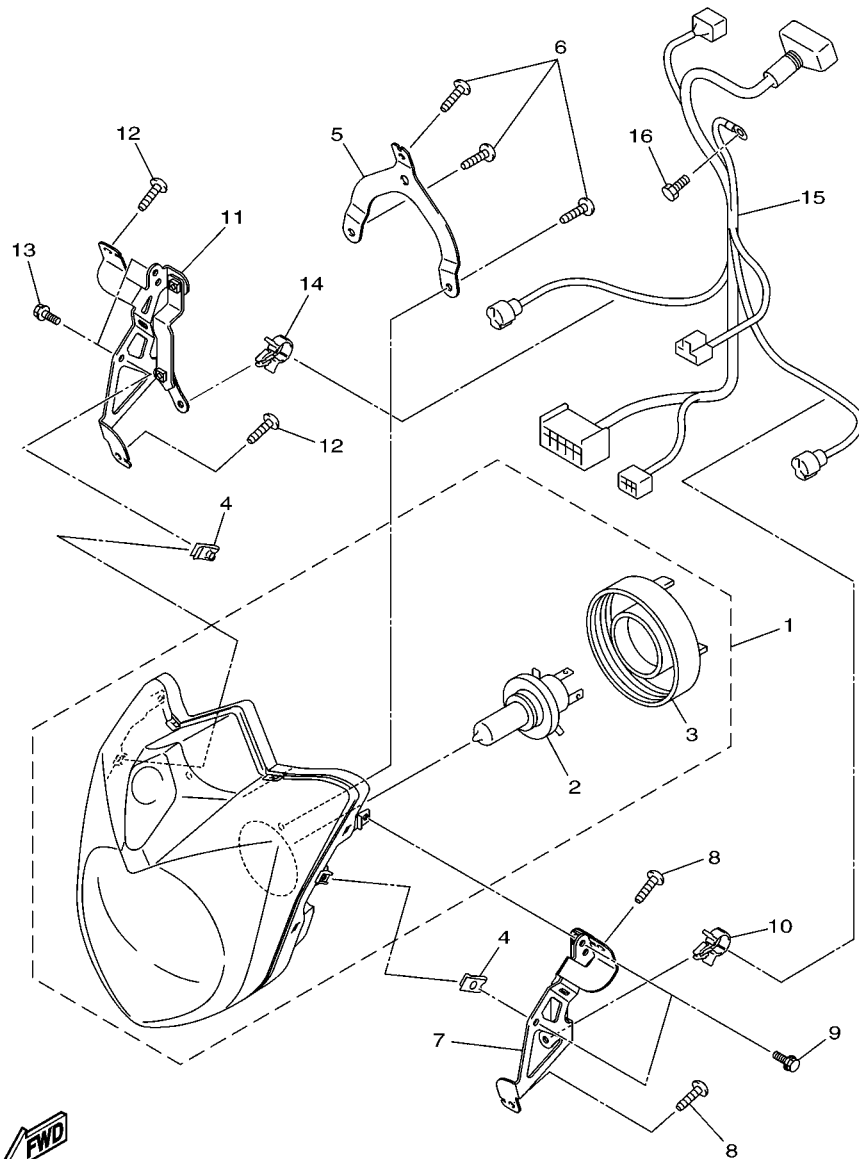
**FWD**  
36P1110-H410

**FIG. 42 METER**

REF. NO.	PART NO.	DESCRIPTION			REMARKS
			36P1	36P2	
1	36P-83500-10	METER ASSY(MPH)	1	1	
2	90160-05012	SCREW, ROUND TAPPING	3	3	
3	90201-05036	WASHER, PLATE	3	3	
4	36P-83615-00	BLIND, METER	1	1	
-----					
-----					
-----					
-----					
-----					
-----					
-----					
-----					
-----					



  
36P1110-H420



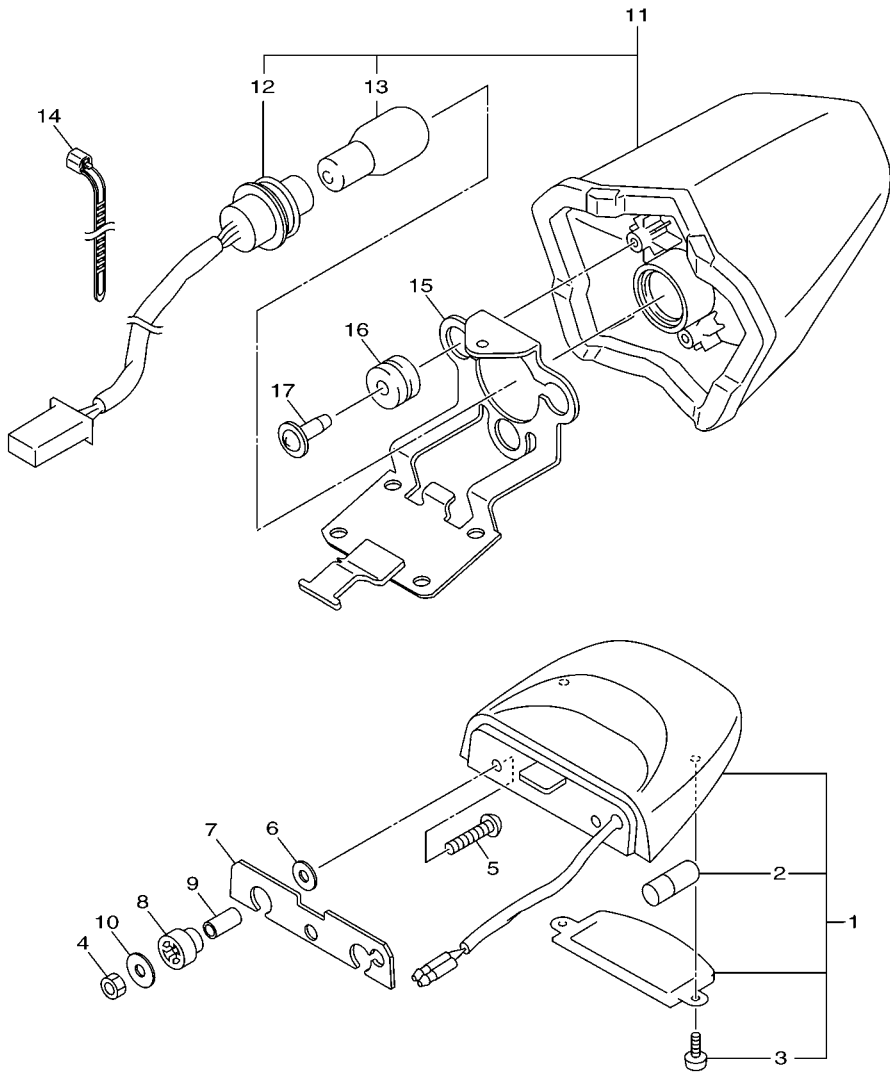
36P1110-H430

FIG. 43 HEADLIGHT

REF. NO.	PART NO.	DESCRIPTION	36P1	36P2	REMARKS
1	36P-84300-00	HEADLIGHT ASSY	1	1	
2	4K0-84314-G0	.BULB (12V 60/55W HALOGEN)	1	1	
3	5JW-84397-00	.COVER, SOCKET	1	1	
4	90183-06069	NUT, SPRING	2	2	
5	36P-28396-00	PLATE 1	1	1	
6	97702-50016	SCREW, TAPPING	3	3	
7	36P-84118-00	STAY, HEADLIGHT 1	1	1	
8	97702-50016	SCREW, TAPPING	2	2	
9	95802-06012	BOLT, FLANGE	2	2	
10	90464-15157	CLAMP	1	1	
11	36P-84119-00	STAY, HEADLIGHT 2	1	1	
12	97702-50016	SCREW, TAPPING	2	2	
13	95802-06012	BOLT, FLANGE	2	2	
14	90464-15157	CLAMP	1	1	
15	36P-84359-00	CORD, HEADLIGHT	1	1	
16	91380-05008	BOLT	1	1	

FIG. 44 TAILLIGHT

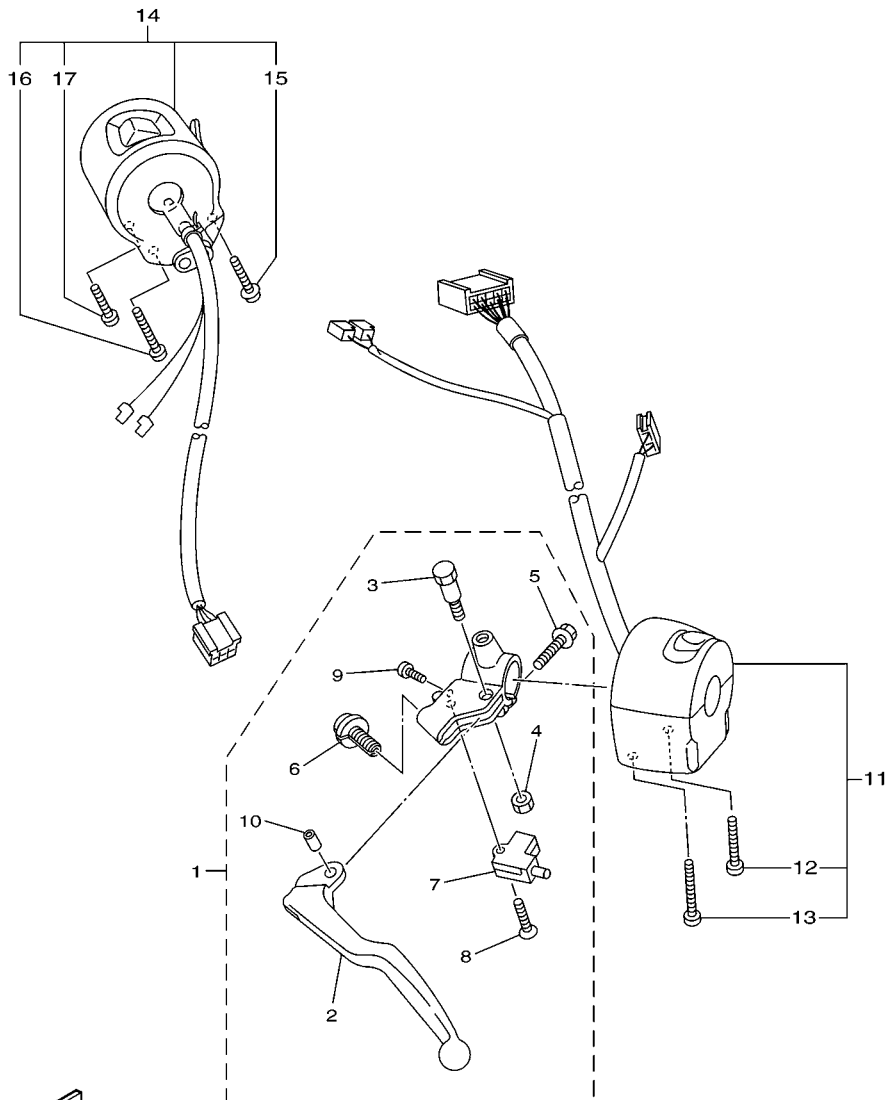
REF. NO.	PART NO.	DESCRIPTION	36P1	36P2			REMARKS
1	5VX-84745-01	LICENCE LIGHT UNIT ASSY	1	1			
2	4HC-84744-00	.BULB (12V-5W)	1	1			
3	97706-04012	.SCREW, TAPPING	2	2			
4	95602-05100	NUT, U	2	2			
5	90111-05030	BOLT,HEX. SOCKET BUTTON	2	2			
6	90201-05043	WASHER, PLATE	2	2			
7	20S-84753-00	DAMPER	1	1			
8	3F9-84553-00	DAMPER	2	2			
9	90387-05049	COLLAR	2	2			
10	90201-05025	WASHER, PLATE	2	2			
11	20S-84710-00	TAILLIGHT UNIT ASSY	1	1			
12	20S-84735-00	.CORD ASSY	1	1			
13	3P6-83331-10	.BULB,FLASHER (12V-21/5W)	1	1			
14	90464-25004	CLAMP	1	1			
15	36P-84519-00	BRACKET, TAILLIGHT	1	1			
16	90480-18276	GROMMET	3	3			
17	90164-05001	SCREW, TAPPING	3	3			



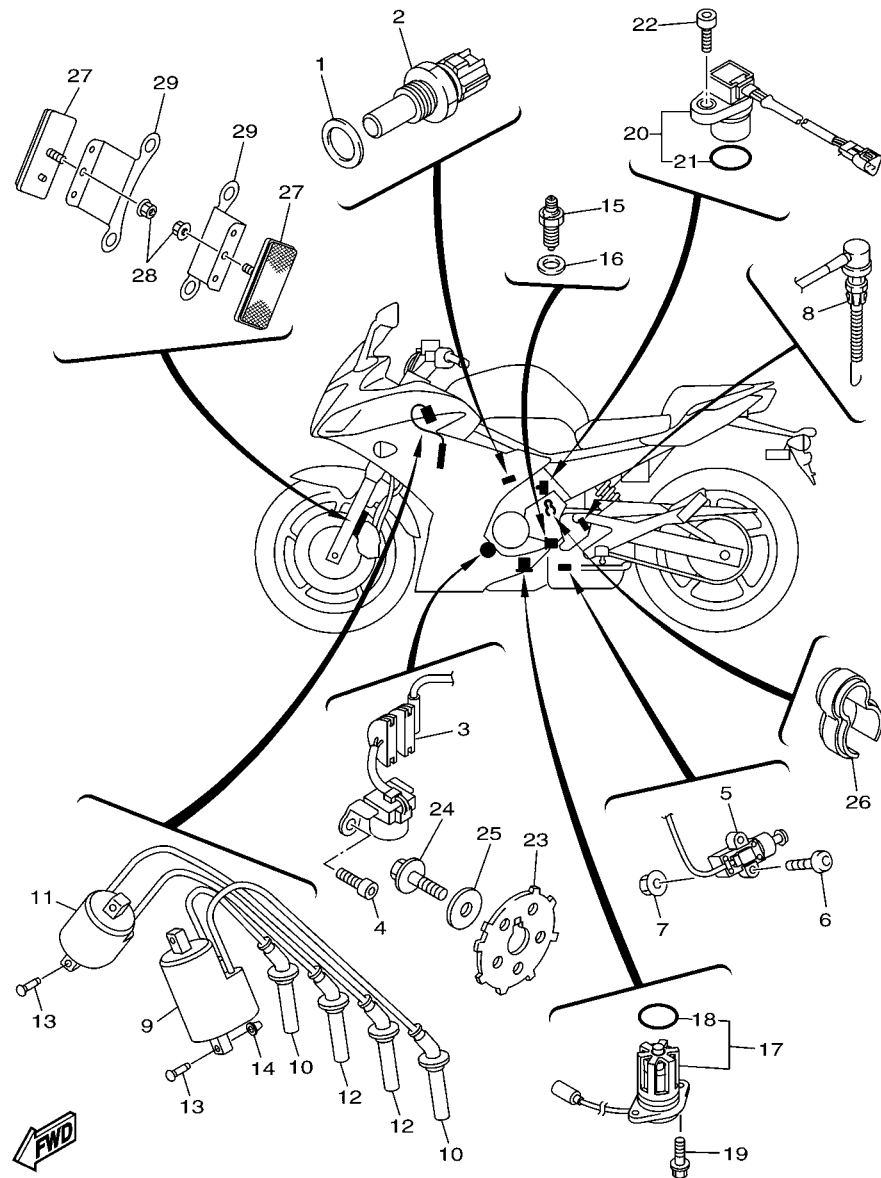
**FWD**  
36P1110-H440

FIG. 45 HANDLE SWITCH & LEVER

REF. NO.	PART NO.	DESCRIPTION	36P1	36P2	REMARKS
1	5VX-82910-01	LEVER HOLDER ASSY (LEFT)	1	1	
2	5EB-83912-03	.LEVER 1	1	1	
3	4XV-83945-00	.BOLT, LEVER	1	1	
4	95607-06100	.NUT, U	1	1	
5	95027-06020	.BOLT, FLANGE	1	1	
6	5LV-83951-00	.BOLT, CABLE ADJUSTING	1	1	
7	3YX-82917-01	.SWITCH	1	1	
8	98704-03020	.SCREW, FLAT HEAD	1	1	
9	98507-04010	.SCREW, PAN HEAD	1	1	
10	5JJ-83913-00	.COLLAR, LEVER 1	1	1	
11	36P-83963-00	SWITCH, HANDLE 3	1	1	
12	98507-05030	.SCREW, PAN HEAD	1	1	
13	98507-05045	.SCREW, PAN HEAD	1	1	
14	5VX-83975-01	SWITCH, HANDLE 2	1	1	
15	97607-05255	.SCREW, WITH WASHER	1	1	
16	98507-05045	.SCREW, PAN HEAD	1	1	
17	98507-05020	.SCREW, PAN HEAD	1	1	



36P1110-H450

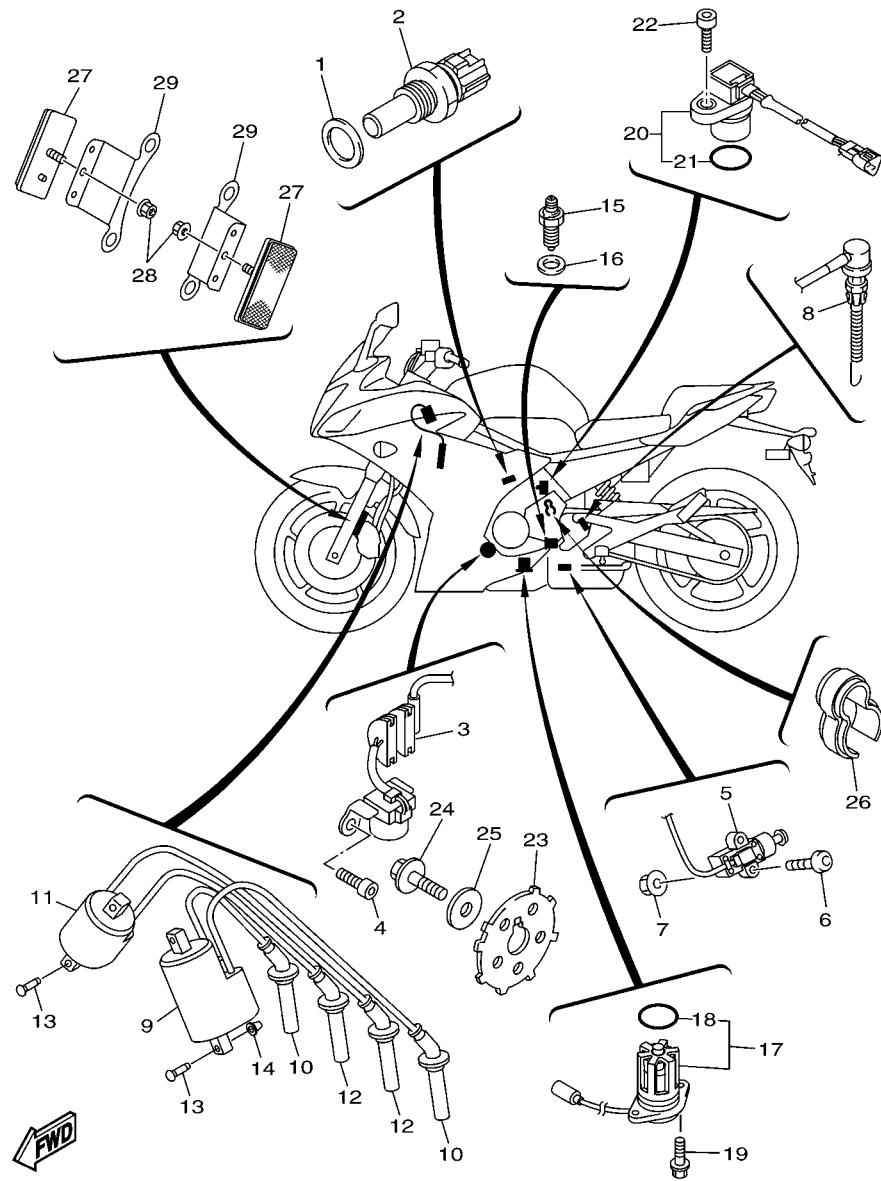


36P1110-H460



FIG. 46 ELECTRICAL 1

REF. NO.	PART NO.	DESCRIPTION	36P1	36P2	REMARKS
1	90201-12790	WASHER, PLATE	1	1	
2	8CC-85790-01	THERMOSENSOR ASSY	1	1	
3	20S-81670-00	PICK-UP ASSY	1	1	
4	90110-06161	BOLT, HEXAGON SOCKET HEAD	2	2	
5	20S-82566-60	SWITCH, SIDE STAND	1	1	
6	92012-05025	BOLT, BUTTON HEAD	2	2	
7	95602-05200	NUT, SELF-LOCKING	2	2	
8	20S-82530-00	STOP SWITCH ASSY	1	1	
9	20S-82310-00	IGNITION COIL ASSY	1	1	
10	20S-82370-01	PLUG CAP ASSY	2	2	
11	20S-82320-00	IGNITION COIL ASSY	1	1	
12	20S-82370-01	PLUG CAP ASSY	2	2	
13	97702-60525	SCREW, TAPPING	2	2	
14	90338-08226	PLUG	2	2	
15	3GB-82540-01	NEUTRAL SWITCH ASSY	1	1	
16	90430-10148	GASKET	1	1	
17	5VX-85720-01	OIL LEVEL GAUGE ASSY	1	1	
18	5VY-8A8E0-00	.O-RING	1	1	
19	90105-06187	BOLT, FLANGE	2	2	
20	4WM-83755-02	SENSOR, SPEED	1	1	
21	4D9-81168-00	.O-RING	1	1	
22	91312-06016	BOLT	1	1	
23	20S-81673-00	ROTOR	1	1	
24	90105-08113	BOLT, FLANGE	1	1	
25	90201-08054	WASHER, PLATE	1	1	
26	90464-15065	CLAMP	1	1	
27	11H-85110-01	REFLECTOR ASSY	2	2	



36P1110-H460

FIG. 46 ELECTRICAL 1

REF. NO.	PART NO.	DESCRIPTION	36P1	36P2		REMARKS
28	95602-05200	NUT, SELF-LOCKING	2	2		
29	36P-85112-00	BRACKET, REFLECTOR 1	2	2		
<hr/>						
<hr/>						
<hr/>						
<hr/>						
<hr/>						
<hr/>						
<hr/>						
<hr/>						
<hr/>						
<hr/>						
<hr/>						

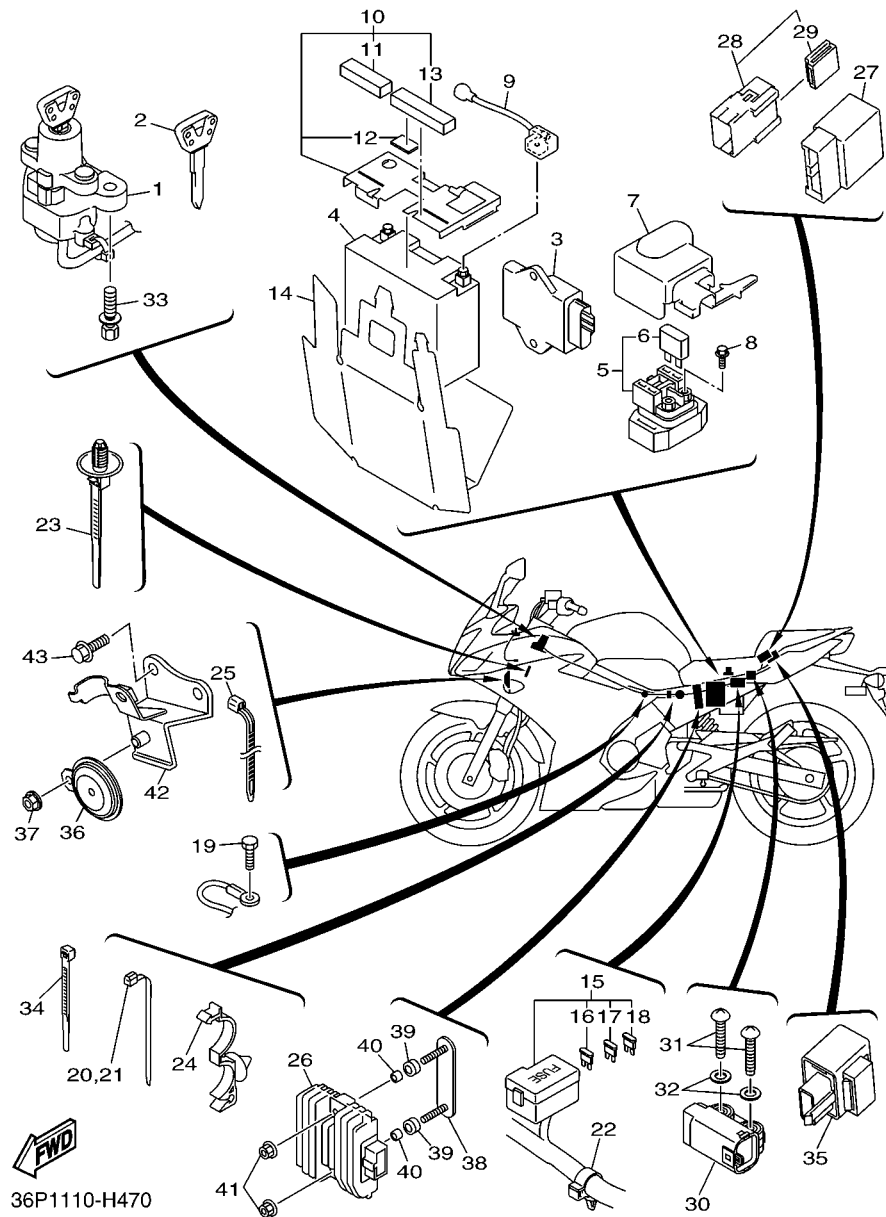


FIG. 47 ELECTRICAL 2

REF. NO.	PART NO.	DESCRIPTION			REMARKS
			36P1	36P2	
1	36P-82501-00	MAIN SWITCH STEERING LOCK	1	1	
2	4BH-82511-09	BLANK KEY	1	1	AP
3	36P-8591A-00	ENGINE CONTROL UNIT ASSY	1	1	
4	4TX-82100-02	BATTERY ASSY (GS GT12B-4)	1	1	
5	4SV-81940-12	STARTER RELAY ASSY	1	1	
6	1AE-82151-00	.FUSE (30A-BL)	2	2	
7	20S-82119-00	COVER, LEAD WIRE	1	1	
8	95022-06008	BOLT, FLANGE	2	2	
9	20S-82115-00	WIRE, PLUS LEAD	1	1	
10	20S-82160-00	BATTERY COVER ASSY	1	1	
11	5VK-21746-00	.DAMPER	1	1	
12	5HN-2139X-00	.DAMPER	1	1	
13	90520-15002	.DAMPER, PLATE	1	1	
14	20S-82122-00	SEAT, BATTERY	1	1	
15	36P-82590-00	WIRE HARNESS ASSY	1	1	
16	5JJ-82151-10	.FUSE (15A-BL)	3	3	
17	5JJ-82151-20	.FUSE (20A-BL)	2	2	
18	5JJ-82151-30	.FUSE (10A-BL)	4	4	
19	91380-06012	BOLT	1	1	
20	90464-13077	CLAMP	1	1	
21	90464-13077	CLAMP	1	1	
22	90464-20010	CLAMP	2	2	
23	90464-20213	CLAMP	2	2	
24	90464-20010	CLAMP	1	1	
25	90464-15195	CLAMP	1	1	
26	5SL-81960-00	RECTIFIER & REGULATOR ASSY	1	1	
27	5VK-81950-40	RELAY ASSY	1	1	



NUMERICAL INDEX

PART NO.	REF. NO.	PART NO.	REF. NO.	PART NO.	REF. NO.	PART NO.	REF. NO.	PART NO.	REF. NO.	PART NO.	REF. NO.
20S-11101-00	1 - 1	1HX-12169-31	3 - 8	5EB-1316E-00	7 - 13	3YF-14613-01	12 - 2	5Y1-16331-01	16 - 6	3D8-2117G-00	20 - 16
5VY-1111G-00	1 - 23	1HX-12169-50	3 - 8	5MT-13300-00	7 - 1	36P-14703-00	12 - 1	132-16346-00	19 - 2	20S-2117K-00	28 - 16
5EB-11133-10	1 - 2	1HX-12169-70	3 - 8	20S-13400-00	8 - 9	5JW-14723-00	11 - 7	20S-16351-00	16 - 11	20S-2117N-00	20 - 10
20S-11134-10	1 - 3	1HX-12169-90	3 - 8	5SL-13410-00	7 - 4	20S-14799-00	12 - 8	20S-16356-00	16 - 29	20S-2117R-00	20 - 12
20S-11165-00	13 - 16	1HX-12169-E0	3 - 8	20S-13414-00	8 - 12	5VX-14807-00	10 - 30	20S-16357-00	16 - 22	20S-2117T-00	20 - 13
20S-11181-00	1 - 14	1HX-12169-G0	3 - 8	5EB-13415-00	7 - 5	5SL-1482K-00	1 - 18	20S-16358-00	16 - 30	36P-2117U-00	20 - 17
1B3-11191-00	1 - 15	1HX-12169-J0	3 - 8	2C0-13416-00	7 - 9	20S-14840-00	11 - 1	20S-16371-10	16 - 3	5GK-2118K-00	27 - 35
20S-11193-00	1 - 17	1HX-12169-L0	3 - 8	5GH-13440-20	8 - 5	5EB-14881-00	11 - 2	20S-16380-00	16 - 24	20S-21228-00	36 - 27
214-11198-01	8 - 11	1HX-12169-N0	3 - 8	5EB-13470-00	8 - 1	20S-14882-00	11 - 4	5LV-16383-00	16 - 5	20S-21249-00	20 - 14
20S-11411-00	2 - 1	1HX-12169-T0	3 - 8	5JW-13473-00	8 - 4	20S-14883-00	11 - 6	20S-16384-00	14 - 30	20S-21296-00	27 - 21
5EB-11416-00	2 - 5	20S-12170-00	4 - 1	5EB-13475-00	8 - 3	5SL-14890-00	1 - 19	20S-16384-10	16 - 4	20S-21308-00	28 - 33
5EB-11416-10	2 - 5	20S-12176-00	4 - 3	3KS-13490-00	8 - 7	5SL-14899-00	1 - 20	1J7-16385-00	16 - 8	3YX-21376-00	21 - 28
5EB-11416-20	2 - 5	20S-12180-00	4 - 2	5VX-13533-00	10 - 29	3UH-14937-00	10 - 13	20S-17121-00	17 - 11	5HN-2139X-00	47 - 12
5EB-11416-30	2 - 5	20S-12210-00	4 - 6	68V-13533-00	10 - 18	5VX-14987-00	10 - 14	20S-17131-00	17 - 6	20S-21445-00	12 - 4
5EB-11416-A0	2 - 5	2C0-12213-00	4 - 7	8FP-13556-00	10 - 3	20S-15100-01	13 - 1	20S-17151-00	17 - 3	20S-2144G-00	35 - 57
20S-11603-00	2 - 7	5BE-12241-00	1 - 16	20S-13586-00	9 - 1	5EB-15155-00	13 - 2	20S-17161-00	17 - 8	4RR-21485-00	35 - 2
5SL-11631-00	2 - 6	2C0-12251-00	4 - 9	20S-13596-00	9 - 2	20S-15163-00	17 - 12	20S-17211-00	17 - 31		35 - 36
20S-11633-00	2 - 9	13S-12252-00	4 - 10	20S-13750-00	10 - 1	20S-15185-00	14 - 36	20S-17221-00	17 - 20	5VX-21511-A0-P2	21 - 1
5VX-11650-00	2 - 2	20S-12405-00	6 - 17	36P-13750-00	10 - 1	36Y-15189-00	13 - 21	20S-17231-00	17 - 28	5VX-21511-A0-P3	21 - 1
5VX-11654-00	2 - 3	5SL-12410-00	6 - 1	5VX-13761-00	10 - 4	5SL-15189-00	13 - 5	20S-17241-00	17 - 25	36P-2153E-00	38 - 8
5VX-11656-00	2 - 4	5VX-12413-00	6 - 2	5EB-13898-00	7 - 7	3F9-15362-00	14 - 11	20S-17251-00	17 - 29		38 - 30
5VX-11656-10	2 - 4	20S-12420-00	5 - 1	20S-13907-00	27 - 8	5EB-15362-00	13 - 23	20S-17261-00	17 - 23	36P-2153E-10	38 - 8
5VX-11656-20	2 - 4	5SL-12422-00	5 - 5	5VX-13971-00	27 - 25	20S-15373-00	9 - 17	20S-17411-00	17 - 1		38 - 30
5VX-11656-30	2 - 4	4C8-12438-00	5 - 4	5JW-14104-00	10 - 22	20S-15377-00	14 - 35	458-17421-00	17 - 16	20S-21611-00	21 - 8
20S-12111-00	3 - 1	5EB-12439-00	5 - 6	5VX-1410E-00	10 - 19	36P-15411-00	14 - 1	278-17424-01	17 - 38	20S-21629-10	21 - 16
20S-12113-00	3 - 4	5VX-1243A-00	5 - 25	4KM-14137-00	10 - 21	20S-15413-00	13 - 18	20S-17460-00	17 - 33	2C0-2162G-00	38 - 26
1HX-12118-00	3 - 6	20S-1243E-00	10 - 26	3H1-14147-00	10 - 23	36P-15416-00	14 - 16	20S-18101-00	19 - 4	36P-21639-00	21 - 34
4TV-12119-00	3 - 7	20S-1244E-00	6 - 31	5PS-14147-00	10 - 5	20S-15418-00	14 - 7	20S-18110-00	19 - 17	20S-2163A-00	22 - 3
20S-12121-00	3 - 2	20S-12450-00	5 - 11	5VX-14148-01	9 - 23	36P-15421-00	14 - 10	20S-18112-00	19 - 14	20S-2163E-00	22 - 9
5EB-12126-00	3 - 3	20S-12461-01	6 - 16	5VX-14149-00	10 - 8	20S-15425-00	14 - 26	5EB-18113-00	19 - 18	36P-2164F-00	21 - 41
5EB-12127-00	3 - 5	22W-12462-00	6 - 28	3XV-14251-00	10 - 16	20S-15441-00	14 - 34		36 - 14	36P-2164G-00	21 - 42
5EB-12153-09	3 - 9	5EB-12469-00	5 - 23	5PW-14251-00	10 - 20	5VX-15451-01	14 - 2	3D8-18115-00	19 - 23	3XW-21668-A1	23 - 21
5EB-12153-10	3 - 9	20S-1246E-00	6 - 7	5VX-14348-00	10 - 2	20S-15456-00	14 - 23	5VX-18116-00	19 - 26	20S-21677-00	21 - 29
1HX-12168-00	3 - 8		6 - 10	5FL-14348-10	10 - 17	20S-15461-00	14 - 13	1D7-18127-00	19 - 3	5VX-21684-00	21 - 37
1HX-12168-20	3 - 8	5GV-1246E-00	5 - 19	5VX-14349-00	10 - 24	20S-15462-00	13 - 19	20S-18140-00	19 - 7	5SL-21686-00	23 - 23
1HX-12168-40	3 - 8	1AA-12535-00	6 - 21	5VX-14396-00	10 - 12	5VX-15484-00	39 - 4	5VX-18154-00	19 - 27	20S-21688-00	21 - 20
1HX-12168-60	3 - 8	20S-12551-00	6 - 8	20S-14411-00	9 - 5	20S-15512-00	15 - 1	2C0-18175-00	19 - 6	20S-21689-00	47 - 38
1HX-12168-80	3 - 8	5EB-12577-01	5 - 15	20S-14421-00	9 - 6	5MT-15515-00	15 - 4	20S-18511-00	18 - 3	20S-21711-00-P2	22 - 1
1HX-12168-A0	3 - 8	20S-12578-00	6 - 5	4D9-1443E-00	9 - 13	5EB-15521-00	15 - 2	20S-18512-00	18 - 4	20S-21711-00-P3	22 - 1
1HX-12168-F0	3 - 8	20S-12579-00	6 - 22	20S-14451-00	9 - 9	20S-15544-00	13 - 25	20S-18513-00	18 - 5	1FK-2171M-00	37 - 24
1HX-12168-H1	3 - 8	4NK-12579-00	5 - 13	20S-14452-00	9 - 7	5SL-15590-00	15 - 3	2C0-18535-00	18 - 6	36P-2171N-00	38 - 13
1HX-12168-K1	3 - 8	20S-12581-00	5 - 14	20S-14453-00	9 - 11	20S-16150-00	16 - 1	2C0-18536-00	18 - 7	36P-2171R-00	38 - 34
1HX-12168-M1	3 - 8	20S-12582-00	6 - 4	20S-14457-00	9 - 10	5EB-16154-00	16 - 2	20S-18540-00	18 - 1	20S-21721-00-P2	22 - 7
1HX-12168-R1	3 - 8	5SL-12588-01	5 - 17	20S-14463-00	9 - 12	1AE-16164-00	16 - 27	136-18542-00	18 - 2	20S-21721-00-P3	22 - 7
1HX-12168-U1	3 - 8	20S-12589-00	6 - 33	5VX-14465-01	10 - 33	4H7-16321-02	16 - 9	2C0-18562-00	18 - 8	36P-2172R-00	37 - 25
1HX-12168-W1	3 - 8	5EB-12822-00	8 - 2	36P-14466-00	27 - 45	5LV-16321-20	16 - 15	36P-21110-00	20 - 1	36P-2172T-00	37 - 30
1HX-12168-Y1	3 - 8	5VX-13160-00	10 - 27	5VX-14503-00	10 - 31	3J2-16324-00	16 - 7	20S-21136-00	20 - 2	20S-2172U-00	22 - 19
1HX-12169-11	3 - 8	5EB-13161-00	7 - 12	5VX-14565-00	10 - 9		16 - 10	36P-2115J-00	21 - 31	4P5-2172W-00	6 - 45

NUMERICAL INDEX

PART NO.	REF. NO.	PART NO.	REF. NO.	PART NO.	REF. NO.	PART NO.	REF. NO.	PART NO.	REF. NO.	PART NO.	REF. NO.
20S-21730-00	22 - 15	5VU-23142-00	26 - 39	36P-24718-00	28 - 21	2D1-2583V-00	36 - 1	4BP-27222-02	36 - 5	36P-28392-00	38 - 27
20S-2173T-00	27 - 32	3VD-23144-00	26 - 12	36P-24724-00	28 - 7	5SL-25852-00	36 - 10	20S-27311-00	35 - 4	36P-28393-00	38 - 6
20S-2173U-00	27 - 34		26 - 32	36P-24728-00	28 - 8	5VS-25852-00	34 - 3	5VX-27315-00	35 - 10	36P-28394-00	38 - 28
20S-21740-00	22 - 21	5VU-23145-00	26 - 9	4NK-24728-00	28 - 3	20S-25854-00	34 - 5	20S-27321-00	35 - 5	36P-28396-00	43 - 5
5VK-21746-00	47 - 11		26 - 29	2GH-24741-00	28 - 23	5SL-25854-00	36 - 8	5VX-27351-00	35 - 9	36P-28398-00	38 - 7
5JW-2174X-00	21 - 12	3VD-23151-00	26 - 6	36P-24750-00	28 - 1	5SL-25855-00	36 - 9	4BP-27413-00	35 - 17	36P-28399-00	38 - 29
5PW-2174X-00	22 - 5		26 - 26	36P-2475B-00	28 - 30	5VS-25855-00	34 - 4		35 - 28	36P-2839A-00	37 - 20
	22 - 11	3VD-23156-00	26 - 11	20S-24773-00	22 - 26	4BP-2585F-01	36 - 4		35 - 42	36P-2839E-00	38 - 5
36P-2176P-00	23 - 22		26 - 31	50W-24780-01	28 - 10	5VS-25867-00	34 - 11		35 - 53	36P-2839F-00	38 - 27
5VX-2178A-00	21 - 38	20S-23170-00	26 - 4	5JW-2478E-00	28 - 14	20S-25872-00	34 - 16	5LV-2741E-01	35 - 31	3JJ-28446-A1	21 - 35
36P-2179W-00	23 - 22		26 - 24	36P-2478X-00	28 - 12	20S-25873-00	34 - 17		35 - 56	4D9-81168-00	46 - 21
26H-21828-00	6 - 40	5VU-23173-00	26 - 7	20S-24792-00	21 - 32	20S-25876-00	34 - 25	5VX-27424-00	35 - 21	20S-81410-00	39 - 6
20S-21843-00	38 - 45		26 - 27		28 - 11	5SL-25876-00	34 - 21		35 - 46	5VX-81450-00	39 - 1
4P5-21871-00	6 - 39	36P-23318-00	25 - 19	3TB-24877-A0	21 - 36	20S-2587A-00	36 - 30	5RT-27431-00	35 - 22	20S-81670-00	46 - 3
4P5-21873-00	6 - 46	4TX-2331G-00	26 - 20	20S-25117-00	29 - 4	4P5-25894-00	36 - 7	4BP-27434-01	19 - 21	20S-81673-00	46 - 23
3P6-21875-00	6 - 42		26 - 40	20S-25168-00-98	29 - 1	20S-25895-00	36 - 12	5VX-27437-00	35 - 25	4WP-81801-00	40 - 3
20S-22110-00	23 - 1	20S-23340-10	26 - 42	20S-25181-00	29 - 10	5VS-2589F-00	34 - 7		35 - 50	5VX-81815-00	40 - 7
5VK-22124-00	23 - 2	20S-23377-00	47 - 42	20S-25183-00	29 - 9	5VS-2589H-00	34 - 6	5RT-27441-00	35 - 47	4WP-81826-00	40 - 2
1AE-22141-00	23 - 10	1W1-23416-00	25 - 3		31 - 18	5SL-25914-00	32 - 9	20S-27442-00	35 - 20	4XV-8182A-00	40 - 5
20S-22151-00	23 - 7	26H-23418-01	25 - 6	146-25315-00	29 - 5	5JW-25914-10	30 - 8	20S-27443-00	35 - 45		40 - 8
1UF-22174-01	31 - 21	4H7-23441-01-98	25 - 16	20S-25317-00	31 - 5		30 - 17	4BH-27451-01	35 - 13	4WP-81844-00	40 - 4
30X-2219X-00	23 - 5	5LV-23442-01	25 - 12	20S-25338-00-98	31 - 1	5DH-25916-00	32 - 14	20S-27453-00	35 - 32	1FK-81847-00	40 - 6
20S-22210-10	24 - 1	3FV-23462-00	26 - 45	1UF-2533A-01	31 - 24	3JD-25917-00	32 - 11	4BH-27461-01	35 - 38	2C0-81890-00	40 - 1
34L-22216-00	24 - 3	341-23469-00	25 - 18	1UF-2533E-01	31 - 25	5SL-25917-00	32 - 6	20S-27463-00	35 - 59	4SV-81940-12	47 - 5
20S-22243-00	24 - 7	20S-24106-00	27 - 31	20S-25364-00	31 - 6	4BP-25919-00	30 - 11	20S-274A3-00	35 - 1	5JJ-81950-20	47 - 28
20S-22311-00	23 - 12	20S-24108-00	27 - 33	20S-25366-00	31 - 10		30 - 20	20S-274A4-00	35 - 35	5VK-81950-40	47 - 27
20S-22325-01	23 - 17	5JW-2413B-00	27 - 36	20S-25377-00	31 - 17	5SL-25919-00	32 - 8	20S-28100-00	28 - 32	5JJ-81952-00	47 - 29
36P-22863-00	38 - 47	20S-2413Y-00	27 - 16	20S-2537W-00	34 - 23	20S-25921-50	32 - 10	4B5-2815K-00	37 - 53	5SL-81960-00	47 - 26
20S-23102-10	26 - 1	20S-2414H-00	27 - 20	20S-25381-00	31 - 26	8CR-25924-00	32 - 13	36P-2830N-00	37 - 10	4TX-82100-02	47 - 4
20S-23103-10	26 - 21	5C7-24170-00	27 - 37	20S-25383-00	31 - 12	5SL-25926-00	32 - 15	36P-2830R-00	37 - 15	20S-82115-00	47 - 9
20S-23110-00	26 - 2	5RB-24180-00	27 - 42	1UF-25388-01	31 - 20	3YX-25929-00	30 - 12	36P-28315-00	37 - 21	20S-82119-00	47 - 7
	26 - 22	20S-24181-00	27 - 19	5MT-25398-00	29 - 8		30 - 21	36P-2833A-00	38 - 17	20S-82122-00	47 - 14
3VD-23115-00	26 - 10	5VX-24181-00	27 - 13		31 - 9	4TT-25937-00	30 - 9	36P-2833E-00	38 - 38	120-82131-00	21 - 10
	26 - 30	4C8-24182-00	22 - 12	5MT-25398-10	29 - 8		30 - 18	36P-28356-00	37 - 41	1AE-82151-00	47 - 6
5VU-23118-00	26 - 18	20S-24183-00	27 - 6		31 - 9	20S-26111-00	33 - 1	36P-2836A-00	38 - 19	5JJ-82151-10	47 - 16
	26 - 38	20S-24191-00	27 - 2	5MT-25398-20	29 - 8	4YR-26240-02	33 - 3	8GC-2836B-01	21 - 24	5JJ-82151-20	47 - 17
5VU-2311H-00	26 - 14	36P-2419F-00	27 - 38		31 - 9	4YR-26241-02	33 - 2	36P-2836E-00	38 - 41	5JJ-82151-30	47 - 18
	26 - 34	36P-24314-00	27 - 44	20S-25446-00	31 - 14	51J-26246-01	33 - 4	36P-2836K-00	37 - 33	20S-82160-00	47 - 10
4KM-23123-01	26 - 46	36P-24315-00	27 - 46	5VX-2580T-00	30 - 5	36P-26280-00	37 - 48	36P-2836L-00	37 - 37	20S-82310-00	46 - 9
3VD-23125-10	26 - 8	68V-24376-00	10 - 15	5VX-2580U-00	30 - 14	36P-26290-00	37 - 49	36P-2836M-00	37 - 39	20S-82320-00	46 - 11
	26 - 28	4KM-24453-00	10 - 7	20S-2580W-00	32 - 3	3C3-26298-00	37 - 51	36P-2836N-00	38 - 49	20S-82370-01	46 - 10
20S-23126-10	26 - 5	5JW-24486-00	27 - 10	20S-2581K-00	36 - 23	36P-26311-00	33 - 5	36P-2836R-00	38 - 52		46 - 12
3VD-23135-10	26 - 3	13S-24491-00	27 - 9	20S-2581T-00	30 - 1	36P-26312-00	33 - 6	20S-28376-00	37 - 22	20S-82386-00	10 - 28
	26 - 23	5JJ-24602-00	27 - 22	1UY-25824-51	32 - 16	5VS-26332-00	34 - 10	36P-2837J-00	37 - 45	36P-82501-00	47 - 1
20S-23136-10	26 - 25	36P-24667-00	27 - 49	1UY-25825-51	32 - 17	20S-26335-00	33 - 7	36P-2837N-00	37 - 13	4BH-82511-09	47 - 2
20S-23141-00	26 - 13	36P-2470F-00	28 - 20	2D1-2582A-00	36 - 3	4D9-27114-00	28 - 5	36P-2837R-00	37 - 18	20S-82530-00	46 - 8
	26 - 33	36P-2470H-00	28 - 2	20S-2582W-00	32 - 1		28 - 22	36P-28381-00	37 - 1	3GB-82540-01	46 - 15
5VU-23142-00	26 - 19	36P-24710-00	28 - 19	5SL-25838-00	32 - 7	20S-27200-00	36 - 13	36P-28391-00	38 - 5	36P-82552-00	25 - 11

NUMERICAL INDEX

PART NO.	REF. NO.	PART NO.	REF. NO.	PART NO.	REF. NO.	PART NO.	REF. NO.	PART NO.	REF. NO.	PART NO.	REF. NO.
20S-82566-60	46 - 5	5MT-84751-00	21 - 46	90105-10365	35 - 6	90111-10036	35 - 37	90183-05042	37 - 7	90208-20001	16 - 17
5PS-82576-01	47 - 30	20S-84753-00	44 - 7	90105-10638	30 - 3	90111-10043	35 - 3	90183-05076	37 - 8	90209-08295	35 - 34
36P-82590-00	47 - 15	5SL-84753-00	37 - 9		30 - 4	90111-10045	35 - 12		37 - 11		35 - 61
5VX-82910-01	45 - 1	11H-85110-01	46 - 27	90105-126A8	39 - 2	90116-10048	31 - 15		37 - 16	90209-21332	17 - 4
3YX-82917-01	45 - 7	36P-85112-00	46 - 29	90109-060E9	38 - 20	90119-06062	27 - 5		38 - 4	90209-21351	17 - 10
2C0-83310-10	41 - 1	3Y6-85130-02	21 - 17		38 - 43	90119-06137	36 - 26		38 - 25	90209-22352	17 - 9
306-83311-40	41 - 12		21 - 39	90109-06168	13 - 11	90119-06147	23 - 8	90183-05M02	37 - 6	90209-25342	17 - 21
	41 - 16	5VX-85720-01	46 - 17	90109-06236	28 - 31	90119-06154	23 - 15		38 - 50	90209-25349	17 - 26
2C0-83318-00	41 - 5	8CC-85790-01	46 - 2	90109-064G6	30 - 2		23 - 18		38 - 53	90209-25350	17 - 27
	41 - 10	2D1-85885-00	10 - 6	90109-066F0	1 - 22	90119-06252	16 - 14	90183-06053	21 - 9	90240-08005	36 - 18
3D7-83318-10	41 - 19	8FP-85886-00	9 - 19	90109-08195	47 - 33	90119-08083	13 - 7	90183-06069	43 - 4	90269-05074	20 - 18
2C0-83320-10	41 - 6	36P-8591A-00	47 - 3	90109-08203	35 - 19	90119-08084	13 - 8	90185-10023	35 - 7	90269-06008	21 - 30
2C0-83330-10	41 - 11	5VY-8A8E0-00	46 - 18		35 - 44	90119-10003	1 - 11	90185-14012	23 - 11		37 - 35
3P6-83331-10	44 - 13	2D1-W0041-00	34 - 2	90109-083G4	32 - 2	90149-06071	39 - 5	90185-16002	31 - 27		38 - 12
2C0-8333A-10	41 - 3	5VX-W0042-50	36 - 2	90109-125F1	24 - 4	90149-06081	28 - 18	90201-04030	47 - 32		38 - 51
	41 - 17	5VX-W0045-00	30 - 10	90110-05028	27 - 11	90149-06082	13 - 6	90201-05025	44 - 10		38 - 54
2C0-83340-10	41 - 15		30 - 19	90110-05112	27 - 23		13 - 17	90201-05036	42 - 3	90269-07001	21 - 25
2C0-8334A-10	41 - 8	20S-W0046-00	32 - 12	90110-06086	5 - 12	90149-06093	39 - 7	90201-05043	21 - 19	90269-07007	20 - 11
	41 - 13	4FU-W0047-00	30 - 7	90110-06161	7 - 8	90149-06302	38 - 9		44 - 6	90269-07008	22 - 25
3GM-83350-01	47 - 35		30 - 16		7 - 11		38 - 15	90201-06088	21 - 47	90269-07010	21 - 14
20S-83371-00	47 - 36	5SL-W0047-00	32 - 5		14 - 18		38 - 31	90201-08053	19 - 22	90269-07016	22 - 6
36P-83500-10	42 - 1	51L-W0048-00	30 - 13		46 - 4		38 - 36	90201-08054	46 - 25		22 - 13
3C3-83513-00	37 - 42		30 - 22	90110-06172	28 - 28	90149-08030	39 - 8	90201-08066	36 - 19		23 - 16
36P-83559-00	37 - 5	5KS-W0057-00	30 - 6	90110-06182	18 - 9	90150-05023	37 - 2	90201-10030	20 - 9	90269-07077	22 - 14
36P-83615-00	42 - 4		30 - 15	90110-06233	9 - 25	90151-06024	17 - 15	90201-10035	35 - 63	90269-08001	23 - 19
4WM-83755-02	46 - 20	5SL-W0057-00	32 - 4	90110-06249	36 - 17	90153-06034	36 - 29	90201-10051	20 - 6	90338-07043	28 - 6
5EB-83912-03	45 - 2	20S-W2341-10	25 - 9	90110-06274	14 - 24	90154-06061	21 - 5		35 - 11		28 - 17
5JJ-83913-00	45 - 10	2TV-W2470-00	28 - 15	90110-06295	14 - 4	90157-05025	35 - 18	90201-10141	25 - 14		38 - 16
5VS-83922-00	34 - 9	36C-W2587-00	34 - 1		14 - 15		35 - 43	90201-12008	39 - 3		38 - 37
4XV-83945-00	45 - 3	36P-Y283G-00-P0	37 - 4	90110-06307	14 - 33	90159-05004	35 - 30	90201-12050	24 - 5	90338-07157	38 - 39
5LV-83951-00	45 - 6	36P-Y283G-20-P1	37 - 4	90110-06329	14 - 8		35 - 55	90201-12051	19 - 19	90338-08226	46 - 14
36P-83963-00	45 - 11	36P-Y283U-00-P0	38 - 1	90110-06330	14 - 9	90159-05187	35 - 29	90201-12575	19 - 12	90340-14132	8 - 10
5VX-83975-01	45 - 14	36P-Y283U-10-P1	38 - 1	90110-06335	4 - 8		35 - 54	90201-12790	46 - 1	90340-20090	1 - 6
4HM-83980-00	34 - 12	36P-Y283V-00-P0	38 - 22	90110-10N52	26 - 17	90160-04009	47 - 31	90201-127E1	19 - 10	90340-32004	14 - 20
36P-84118-00	43 - 7	36P-Y283V-10-P1	38 - 22		26 - 37	90160-05012	21 - 22	90201-16026	31 - 28	90386-14171	36 - 15
36P-84119-00	43 - 11	20S-YK241-00-P0	27 - 1	90111-05007	38 - 10		42 - 2	90201-177G4	19 - 8	90387-05049	44 - 9
36P-84300-00	43 - 1	20S-YK241-00-P2	27 - 1		38 - 32	90164-05001	44 - 17	90201-20023	17 - 34	90387-06057	38 - 3
4K0-84314-G0	43 - 2	90105-06027	1 - 5	90111-05030	44 - 5	90170-06026	19 - 24	90201-20030	16 - 16		38 - 24
36P-84359-00	43 - 15	90105-06053	5 - 24	90111-05034	37 - 34	90170-08010	36 - 6	90201-20278	17 - 36	90387-06068	27 - 4
5JW-84397-00	43 - 3	90105-060A6	6 - 50		37 - 38	90176-22081	25 - 8	90201-220T0	25 - 7	90387-06091	28 - 24
36P-84519-00	44 - 15	90105-06122	28 - 26		37 - 40	90179-05523	37 - 3	90201-255A6	16 - 26	90387-06130	22 - 16
3F9-84553-00	44 - 8	90105-06145	13 - 15		38 - 48	90179-08410	12 - 3	90202-05180	38 - 11		22 - 22
20S-84710-00	44 - 11	90105-06164	6 - 3	90111-06038	22 - 18	90179-10658	20 - 5		38 - 33		23 - 13
1A2-84714-41	41 - 2	90105-06187	46 - 19		22 - 24	90179-20007	16 - 18	90202-06004	37 - 36		38 - 14
	41 - 7	90105-07004	4 - 4	90111-06098	19 - 28	90179-20011	17 - 35	90202-24190	25 - 2		38 - 35
20S-84735-00	44 - 12	90105-08113	46 - 24	90111-06127	27 - 12	90179-25033	25 - 4	90202-26142	25 - 5	90387-06133	23 - 9
4HC-84744-00	44 - 2	90105-08164	12 - 5	90111-08066	35 - 33	90183-05008	37 - 12	90206-12005	19 - 20	90387-0614M	6 - 25
5VX-84745-01	44 - 1	90105-10297	20 - 4		35 - 60		37 - 17	90206-14086	36 - 16		6 - 26

NUMERICAL INDEX

PART NO.	REF. NO.	PART NO.	REF. NO.	PART NO.	REF. NO.	PART NO.	REF. NO.	PART NO.	REF. NO.	PART NO.	REF. NO.
90387-061W6	27 - 14	90450-32006	5 - 21	90467-11090	6 - 15	91312-06020	9 - 3	93106-22019	23 - 4	94112-17103	29 - 6
90387-06205	9 - 21		6 - 13		6 - 36		19 - 15	93106-40041	31 - 13	94116-17015	31 - 7
90387-06232	21 - 26		6 - 27		6 - 38	91312-06025	8 - 13	93108-35004	23 - 6	94116-17019	31 - 7
90387-06299	27 - 18	90450-35001	5 - 16		10 - 25		13 - 20	93109-08061	14 - 29	94580-25080	7 - 6
90387-062L2	27 - 41	90450-38003	5 - 20	90467-110A2	5 - 26	91312-06060	1 - 12		16 - 23	94582-24118	31 - 19
90387-06372	19 - 29	90450-53002	9 - 15	90467-14015	9 - 22	91312-06090	27 - 15	93109-18020	24 - 2	94591-68120	4 - 5
90387-064T3	37 - 52	90450-63003	9 - 4	90467-15001	9 - 18	91312-08025	21 - 27	93210-04092	13 - 3	94701-00318	1 - 13
	47 - 40	90464-07012	6 - 48	90467-17003	9 - 24	91312-08030	25 - 10	93210-06632	16 - 28	95022-06008	47 - 8
90387-065J6	21 - 2	90464-10233	6 - 51		11 - 8		25 - 17	93210-06667	7 - 15	95022-06012	13 - 26
90387-07391	37 - 44	90464-13077	47 - 20	90467-17089	11 - 3	91312-10025	26 - 43	93210-09165	7 - 14		36 - 31
90387-077M3	28 - 29		47 - 21		11 - 5	91312-10035	20 - 7		13 - 24	95022-06014	14 - 31
90387-08089	22 - 28	90464-15065	46 - 26	90467-17128	11 - 9	91312-10045	20 - 8	93210-14003	7 - 10	95022-06025	40 - 9
90387-1003G	35 - 62	90464-15157	37 - 27	90467-200A0	6 - 34	91314-06030	14 - 5	93210-15566	8 - 8	95022-08012	1 - 8
90387-123X6	24 - 8		43 - 10	90480-01558	37 - 29	91314-08040	26 - 41	93210-16325	13 - 22	95024-06020	5 - 7
90387-2202V	17 - 30		43 - 14		37 - 32	91317-05010	27 - 24	93210-27194	14 - 12	95024-06030	21 - 6
90387-25024	16 - 20	90464-15195	47 - 25		38 - 21	91380-05008	43 - 16	93210-32172	14 - 19	95027-06020	46 - 5
90387-2504A	17 - 18	90464-16003	36 - 22		38 - 44	91380-06012	47 - 19	93210-33133	5 - 10	95302-06600	15 - 31
90387-2513E	17 - 7	90464-16005	27 - 26	90480-07003	21 - 11	91402-20012	36 - 20	93210-35N02	26 - 15	95302-08600	31 - 22
90387-253M6	17 - 2	90464-16006	25 - 21	90480-08005	22 - 2	91402-25015	35 - 16		26 - 35	95314-06700	19 - 25
90387-2813C	17 - 19		37 - 26		22 - 8		35 - 27	93210-46001	5 - 22	95602-04100	21 - 45
90387-2813D	17 - 24	90464-16011	23 - 20	90480-10334	22 - 17		35 - 41	93306-00106	5 - 2	95602-05100	21 - 18
90401-10020	34 - 18	90464-18002	21 - 4		22 - 23		35 - 52	93306-00304	16 - 12		44 - 4
	36 - 24		34 - 24	90480-12072	21 - 3	91701-08042	35 - 15	93306-20331	29 - 2	95602-05200	21 - 40
90401-10038	34 - 19	90464-20010	47 - 22	90480-12314	9 - 16		35 - 26	93306-20483	17 - 14		46 - 7
90401-20145	8 - 6		47 - 24	90480-13163	27 - 40		35 - 40		17 - 37		46 - 28
90413-08012	10 - 35	90464-20213	47 - 23	90480-14003	38 - 2		35 - 51	93306-20659	31 - 11	95602-06100	21 - 48
90430-06014	5 - 8	90464-23041	10 - 32		38 - 23	91808-16023	1 - 7	93306-30317	31 - 2	95602-10100	25 - 15
90430-08119	1 - 9	90464-24230	38 - 42	90480-14004	37 - 43	91808-17032	7 - 2		31 - 4	95602-10200	31 - 16
90430-08143	14 - 21	90464-25004	44 - 14	90480-14016	28 - 27	92012-05025	46 - 6	93306-30525	17 - 13	95607-06100	45 - 4
90430-10005	34 - 20	90464-31001	21 - 21	90480-15363	6 - 24	92012-06012	28 - 9	93306-30550	17 - 17	95612-08625	1 - 10
	36 - 25	90464-34002	13 - 27	90480-15M06	28 - 25	92012-06020	23 - 14	93310-340N8	16 - 19	95612-12100	24 - 6
90430-10148	46 - 16	90465-08045	14 - 6	90480-16007	47 - 39	92012-08020	22 - 27	93317-11295	14 - 27	95617-06100	34 - 8
90430-10171	26 - 16	90465-10030	8 - 14	90480-16010	27 - 3	92014-06010	12 - 9		19 - 16	95702-06500	21 - 7
	26 - 36	90465-10042	14 - 25	90480-18276	44 - 16	92014-08014	14 - 22	93317-22262	23 - 3		21 - 33
90445-05003	37 - 23	90465-14011	14 - 17	90480-23345	21 - 23	92014-08020	35 - 58	93399-99931	25 - 1		27 - 17
90445-08025	6 - 43	90465-15011	27 - 7	90501-12743	35 - 23	92902-04100	34 - 14	93399-99932	26 - 44		28 - 4
90445-081F2	6 - 41		47 - 34		35 - 48	92902-04600	21 - 44	93440-10153	1 - 4		28 - 13
90445-106J2	27 - 27	90467-08075	6 - 44	90501-225A9	16 - 13		34 - 15	93440-25186	17 - 5		37 - 50
	27 - 29		6 - 49	90506-15005	19 - 1	92902-08600	31 - 23	93440-28062	17 - 22		47 - 41
90445-11065	27 - 43	90467-090A2	27 - 28	90506-23008	36 - 21	92907-06100	6 - 19	93450-17129	2 - 8	95702-08500	47 - 37
90445-12009	6 - 37		27 - 30	90506-23018	35 - 8	92907-06600	6 - 20	93501-04011	35 - 24	95802-06010	20 - 15
90445-12012	6 - 11	90467-10008	10 - 34	90508-18052	16 - 25	92907-10200	25 - 13		35 - 49		27 - 50
90450-22017	5 - 18	90467-10041	9 - 14	90508-20572	35 - 14	93101-12173	5 - 3		16 - 21	95802-06012	21 - 13
	6 - 35	90467-100A1	27 - 30		35 - 39	93102-12106	19 - 11		4 - 11		22 - 20
90450-32003	6 - 6		27 - 47	90508-32020	19 - 5	93102-12224	14 - 28	93607-44002	14 - 14		25 - 20
	6 - 9		27 - 51	90520-15002	47 - 13	93102-25017	29 - 3	93608-17263	29 - 7		34 - 22
	6 - 14	90467-11044	36 - 11	91312-06016	46 - 22	93102-25044	31 - 3	93900-00030	31 - 8		36 - 28
	6 - 23	90467-11090	6 - 12	91312-06020	1 - 21	93102-35423	17 - 32	94112-17102	29 - 6		37 - 28

NUMERICAL INDEX

PART NO.	REF. NO.	PART NO.	REF. NO.	PART NO.	REF. NO.	PART NO.	REF. NO.	PART NO.	REF. NO.	PART NO.	REF. NO.
95802-06012	37 - 31	98507-06012	10 - 11								
	43 - 9	98704-03020	45 - 8								
	43 - 13	98902-05012	9 - 20								
95802-06014	38 - 18	98902-05020	9 - 8								
	38 - 40	99001-10600	19 - 13								
95802-06016	27 - 39	99009-12400	5 - 9								
	47 - 43	99009-17400	19 - 9								
95802-06025	6 - 29	99530-08012	14 - 3								
95802-06030	6 - 30	99530-10014	13 - 4								
95802-08016	27 - 48	99530-10114	1 - 24								
95812-06030	7 - 3	99590-08012	14 - 32								
95812-06045	13 - 13										
95812-06055	13 - 9										
95812-06065	13 - 12										
95812-06100	13 - 14										
95812-08065	13 - 10										
95822-06010	21 - 15										
95822-06012	6 - 32										
95822-06014	38 - 46										
95822-06025	37 - 47										
95822-08020	20 - 3										
95822-08035	37 - 46										
95822-10020	6 - 47										
95824-06016	12 - 7										
95824-06020	12 - 6										
97307-06012	6 - 18										
97607-05255	45 - 15										
97702-40010	41 - 4										
	41 - 9										
	41 - 14										
	41 - 18										
97702-50014	22 - 4										
	22 - 10										
97702-50016	37 - 14										
	37 - 19										
	43 - 6										
	43 - 8										
	43 - 12										
97702-60525	46 - 13										
97706-04012	44 - 3										
98502-04012	21 - 43										
	34 - 13										
98507-04010	45 - 9										
98507-05010	10 - 10										
98507-05020	45 - 17										
98507-05030	45 - 12										
98507-05045	45 - 13										
	45 - 16										