



PARTS CATALOGUE

FZ6-S (5VX1) EUROPE,SOUTH AFRICA FZ6-SS (5VX2) AUSTRALIA



1C5VX-300E1

(2C5VX-300E1)

NEWS No.	DATE	COMMENT
PE0-MC-040017	Apr.,08,2004	FIG.16: CLUTCH ILLUSTRATION CORRECTION
PE0-MC-050060	Jun.,27,2005	FIG.16: CLUTCH ILLUSTRATION CORRECTION
PE0-MC-060020	Mar.,14,2006	FIG.12: EXHAUST LIST CORRECTION
PE0-MC-090082	Dec.,4,2009	FIG.42: HEADLIGHT ILLUSTRATION CORRECTION

FZ6-S/FZ6-SS
PARTS CATALOGUE
©2003 by Yamaha Motor Co., Ltd.
1st edition, August 2003
All rights reserved.
Any reprinting or unauthorized use
without the written permission of
Yamaha Motor Co., Ltd.
is expressly prohibited.
Printed in Japan.

A3

FZ6-S



A4

FOREWORD

This Parts Catalogue is related to the parts for the model(s) on the cover page. When you are ordering replacement parts, please refer to this Parts Catalogue and quote both part numbers and part names correctly.

1. Modifications or additions which have been made after the issue of the Parts Catalogue will be announced in the Parts News.

It is advisable that you make the necessary corrections to the Parts Catalogue according to the Parts News.

2. Abbreviations

The following abbreviations are used in this Parts Catalogue.

“UR” Use specified parts number.

“UN” Use as many as needed.

“AP” Alternate Parts

“LM” Locally Made (Parts need to be ordered locally)

“F#” Frame No. (Applicable machine No.)

“O/S” Over Size

3. The number of components for assembly

- Parts, which are to be supplied in an assembly, are listed with a dot (.) in front of the part name as shown below.
- The numeral appearing to the right of each component part indicates the quantity of parts for each assembly unit.

PART NO.	DESCRIPTION	Q'TY	REMARKS
2F5-83310-60	FRONT FLASHER LIGHT ASSY	2	
115-83311-60	.BULB (6V-18W)	1	

4. Applicable colours of graphics are represented in the “REMARKS” as shown below.

PART NO.	DESCRIPTION	Q'TY	REMARKS
2N4-24110-00-X5	FUEL TANK COMP.	2	MXR
3J1-24240-10	.GRAPHIC, FUEL TANK	1	FOR MXR

5. Note that the illustrations for reference in finding parts numbers are not to be used for assembling. When assembling, please use the applicable service manual.

6. The asterisk (*) before a reference number indicates modified items after the first edition.

FOREWORD

7. Applicable Serial No.

Engine Serial No.

Frame Serial No.

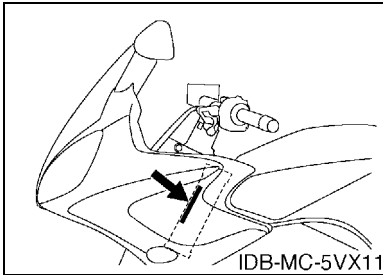
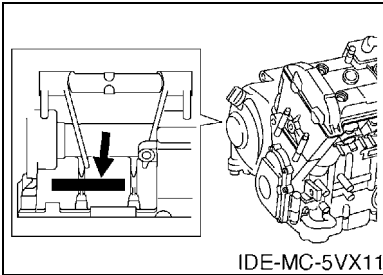

8. Applicable Colour Code (The (*) mark shows Model colour.)

Abbreviation	Colour Name	Colour Code
DNBME(*)	DARK GRAYISH BLUE METALLIC E	0866
DPBML(*)	DARK PURPLISH BLUE METALLIC L	0865
S3(*)	SILVER 3	0791
SL	SILVER	0035

MODEL LABEL

(1) A label called "Model Label" is affixed in the location as indicated in (3) below. When using this parts catalogue, please be sure to cross-reference the "model code – production code No." in the catalogue with the "model code – production code No." indicated on the Model Label affixed onto the product concerned.

(2) "Model Label" Indication

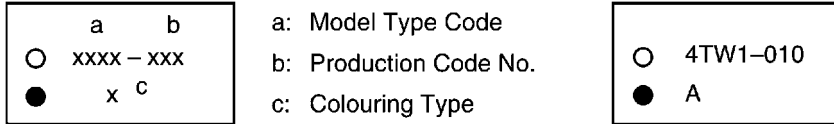

(3) Model Label Affixing Location

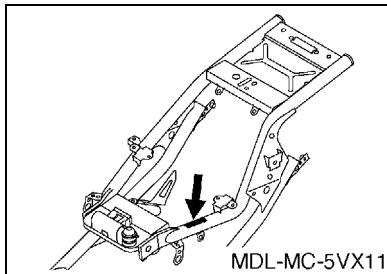

(4) Colouring Information

Model Code	Colouring Type Code	Colour Code	Colour Name	Abbreviation
5VX1	A	0791	SILVER 3	S3
	B	0865	DARK PURPLISH BLUE METALLIC L	DPBML
	C	0866	DARK GRAYISH BLUE METALLIC E	DNBME
5VX2	A	0791	SILVER 3	S3
	B	0865	DARK PURPLISH BLUE METALLIC L	DPBML
	C	0866	DARK GRAYISH BLUE METALLIC E	DNBME

(5) Model Code – Production Code Number of Model Listed in This Parts Catalogue

Model Code	Production Code No.	Country (destination)	Model Code	Production Code No.	Country (destination)
5VX1	010	ITALY			
	020	BELGIUM			
	040	DENMARK			
		FINLAND			
		NORWAY			
	070	UNITED KINGDOM			
	080	GREECE			
	090	NETHERLANDS			
	100	PORTUGAL			
110	SOUTH AFRICA				
5VX2	010	AUSTRALIA			

CONTENTS

ENGINE

CYLINDER	B2
CRANKSHAFT & PISTON	B3
VALVE	B4
CAMSHAFT & CHAIN	B6
WATER PUMP	B7
RADIATOR & HOSE	B8
OIL PUMP	B10
OIL CLEANER	B11
INTAKE	B12
INTAKE 2	B13
AIR INDUCTION SYSTEM	B15
EXHAUST	C2
CRANKCASE	C4
CRANKCASE COVER 1	C6
STARTER	C8
CLUTCH	C9
TRANSMISSION	C11
SHIFT CAM & FORK	C13
SHIFT SHAFT	C14

CHASSIS

FRAME	D2
FENDER	D4
SIDE COVER	D7
REAR ARM	D9
REAR SUSPENSION	D10
STEERING	D11
FRONT FORK	D12
FUEL TANK	D14
SEAT	E2
FRONT WHEEL	E3
FRONT BRAKE CALIPER	E4
REAR WHEEL	E5
REAR BRAKE CALIPER	E7
STEERING HANDLE & CABLE	E8
FRONT MASTER CYLINDER	E9
STAND & FOOTREST	E10
REAR MASTER CYLINDER	E12
COWLING 1	E13
GENERATOR	E15
STARTING MOTOR	F2

FLASHER LIGHT	F3
METER	F4
HEADLIGHT	F5
TAILLIGHT	F6
HANDLE SWITCH & LEVER	F7
ELECTRICAL 1	F8
ELECTRICAL 2	F9

INDEX

NUMERICAL INDEX	M1
-----------------------	----

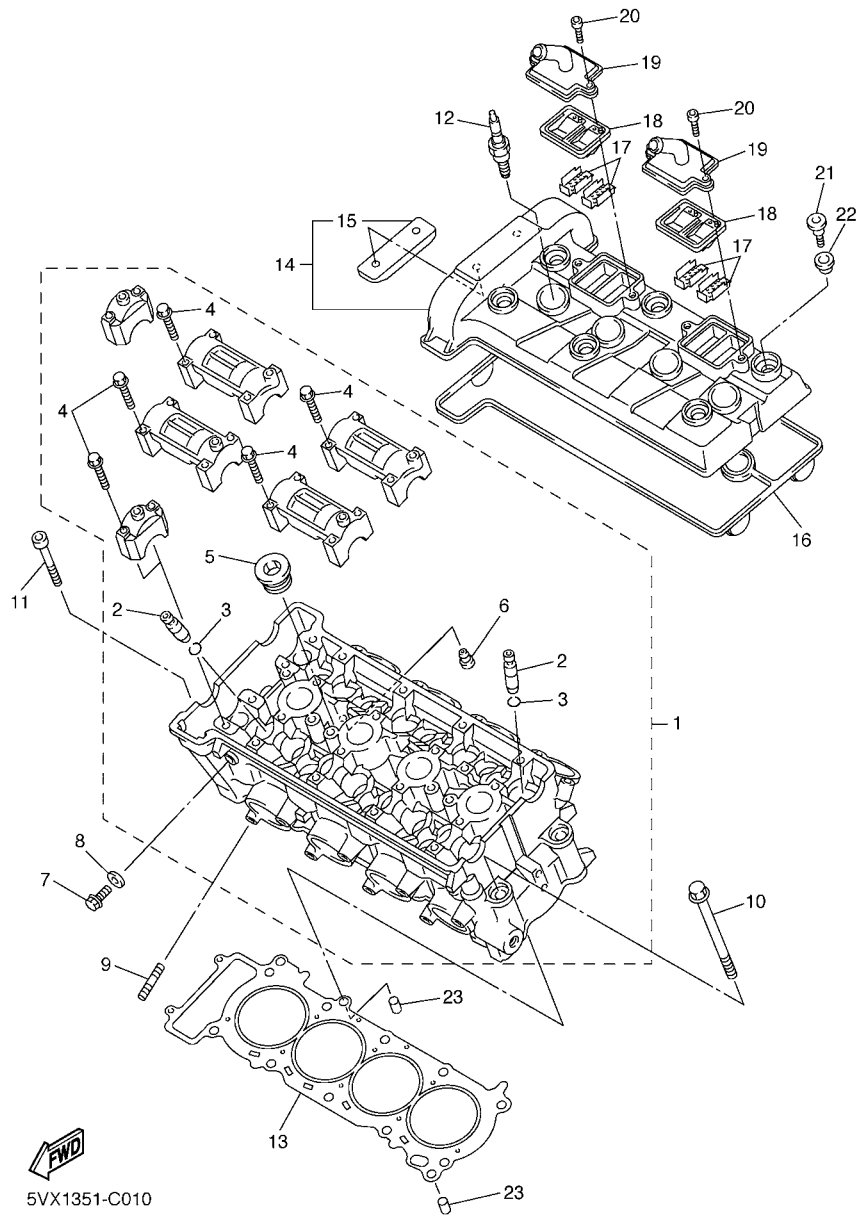

5VX1351-C010

FIG. 1 CYLINDER

REF. NO.	PART NO.	DESCRIPTION	5VX1	5VX2			REMARKS
1	5VX-11101-00	CYLINDER HEAD ASSY	1	1			
2	5EB-11133-10	.GUIDE, VALVE 1	16	16			
3	93440-10153	.CIRCLIP	16	16			
4	90105-06027	.BOLT, FLANGE	20	20			
5	90340-20090	.PLUG, STRAIGHT SCREW	3	3			
6	11H-15138-00	.NOZZLE 1	1	1			
7	95027-08012	BOLT, FLANGE	1	1			
8	90430-08119	GASKET	1	1			
9	95617-08625	BOLT, STUD	8	8			
10	90119-10003	BOLT, WITH WASHER	10	10			
11	91314-06060	BOLT	2	2			
12	94701-00403	PLUG, SPARK	4	4			
13	5VX-11181-00	GASKET, CYLINDER HEAD 1	1	1			
14	5VX-11191-00	COVER, CYLINDER HEAD 1	1	1			
15	5BE-12241-00	.GUIDE, STOPPER 2	1	1			
16	5SL-11193-00	GASKET, HEAD COVER 1	1	1			
17	5SL-1482K-00	PLATE	4	4			
18	5SL-14890-00	REED VALVE ASSY	2	2			
19	5SL-14899-00	CAP, CASE	2	2			
20	91317-06020	BOLT	4	4			
21	90109-066F0	BOLT	6	6			
22	4KG-1111G-00	RUBBER, MOUNT 1	6	6			
23	99530-10114	PIN, DOWEL	2	2			

FIG. 2 CRANKSHAFT & PISTON

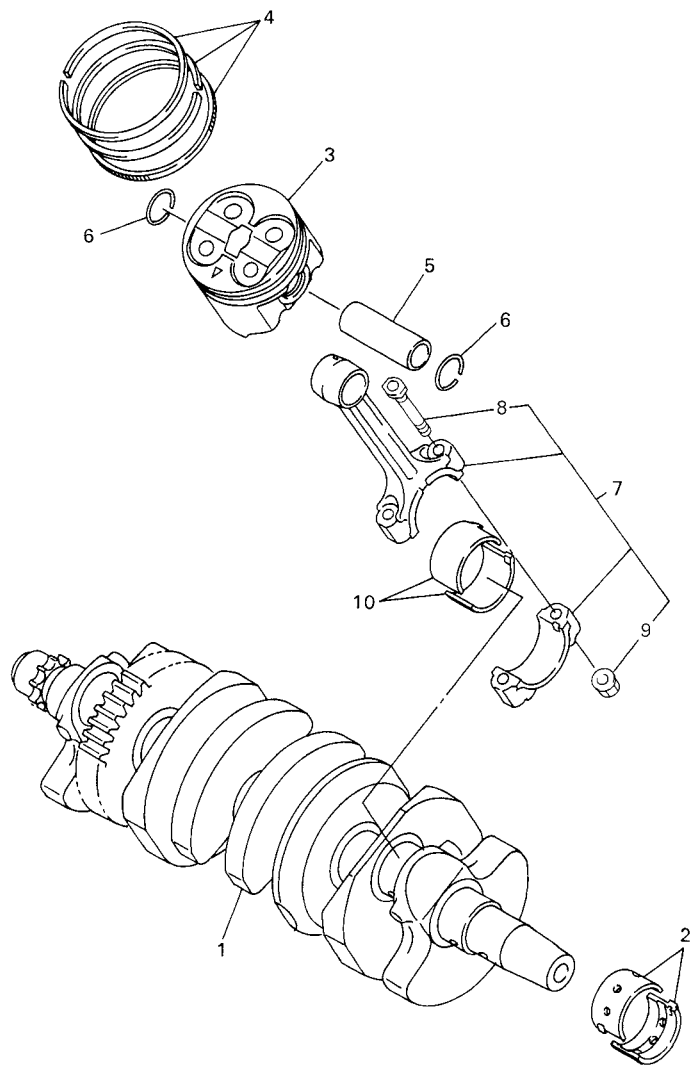

REF. NO.	PART NO.	DESCRIPTION	5VX1	5VX2	REMARKS
1	5SL-11411-00	CRANKSHAFT	1	1	
2	5EB-11416-A0	PLANE BEARING, CRANKSHAFT 1	10	10	UR WHITE
	5EB-11416-00	PLANE BEARING, CRANKSHAFT 1	10	10	UR BLUE
	5EB-11416-10	PLANE BEARING, CRANKSHAFT 1	10	10	UR BLACK
	5EB-11416-20	PLANE BEARING, CRANKSHAFT 1	10	10	UR BROWN
	5EB-11416-30	PLANE BEARING, CRANKSHAFT 1	10	10	UR GREEN
3	5SL-11631-00	PISTON (STD)	4	4	
4	5SL-11603-00	PISTON RING SET (STD)	4	4	
5	5EB-11633-00	PIN, PISTON	4	4	
6	93450-17129	CIRCLIP	8	8	
7	5SL-11650-00	CONNECTING ROD ASSY	4	4	
8	5SL-11654-00	.BOLT, CONNECTING ROD	2	2	
9	90179-07652	.NUT	2	2	
10	5SL-11656-00	PLANE BEARING, CONNECTING ROD	8	8	UR BLUE
	5SL-11656-10	PLANE BEARING, CONNECTING ROD	8	8	UR BLACK
	5SL-11656-20	PLANE BEARING, CONNECTING ROD	8	8	UR BROWN
	5SL-11656-30	PLANE BEARING, CONNECTING ROD	8	8	UR GREEN



5EB3351-9020

FIG. 3 VALVE

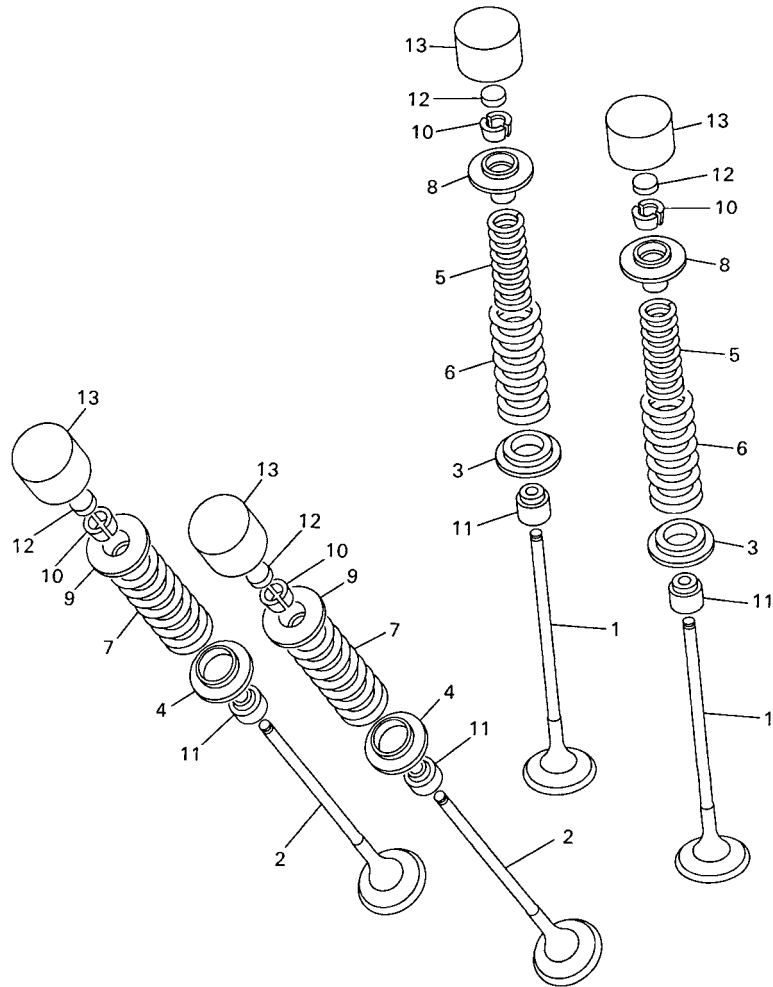

REF. NO.	PART NO.	DESCRIPTION	5VX1	5VX2	REMARKS
1	5EB-12111-00	VALVE, INTAKE	8	8	
2	5SL-12121-00	VALVE, EXHAUST	8	8	
3	5SL-12116-00	SEAT, VALVE SPRING	8	8	
4	5EB-12126-00	SEAT, VALVE SPRING 2	8	8	
5	5EB-12113-00	SPRING, VALVE INNER	8	8	
6	5EB-12114-00	SPRING, VALVE OUTER	8	8	
7	5EB-12124-01	SPRING, VALVE OUTER	8	8	
8	5EB-12117-00	RETAINER, VALVE SPRING	8	8	
9	5EB-12127-00	RETAINER, VALVE SPRING	8	8	
10	1HX-12118-00	COTTER, VALVE	32	32	
11	4TV-12119-00	SEAL, VALVE STEM	16	16	
12	1HX-12168-00	PAD, ADJUSTING 2 (1.20)	16	16	UR
	1HX-12168-20	PAD, ADJUSTING 2 (1.25)	16	16	UR
	1HX-12168-40	PAD, ADJUSTING 2 (1.30)	16	16	UR
	1HX-12168-60	PAD, ADJUSTING 2 (1.35)	16	16	UR
	1HX-12168-80	PAD, ADJUSTING 2 (1.40)	16	16	UR
	1HX-12168-A0	PAD, ADJUSTING 2 (1.45)	16	16	UR
	1HX-12168-F0	PAD, ADJUSTING 2 (1.50)	16	16	UR
	1HX-12168-H1	PAD, ADJUSTING 2 (1.55)	16	16	UR
	1HX-12168-K1	PAD, ADJUSTING 2 (1.60)	16	16	UR
	1HX-12168-M1	PAD, ADJUSTING 2 (1.65)	16	16	UR
	1HX-12168-R1	PAD, ADJUSTING 2 (1.70)	16	16	UR
	1HX-12168-U1	PAD, ADJUSTING 2 (1.75)	16	16	UR
	1HX-12168-W1	PAD, ADJUSTING 2 (1.80)	16	16	UR
	1HX-12168-Y1	PAD, ADJUSTING 2 (1.85)	16	16	UR
	1HX-12169-11	PAD, ADJUSTING 2 (1.90)	16	16	UR
	1HX-12169-31	PAD, ADJUSTING 2 (1.95)	16	16	UR



5EB3351-9030

B4

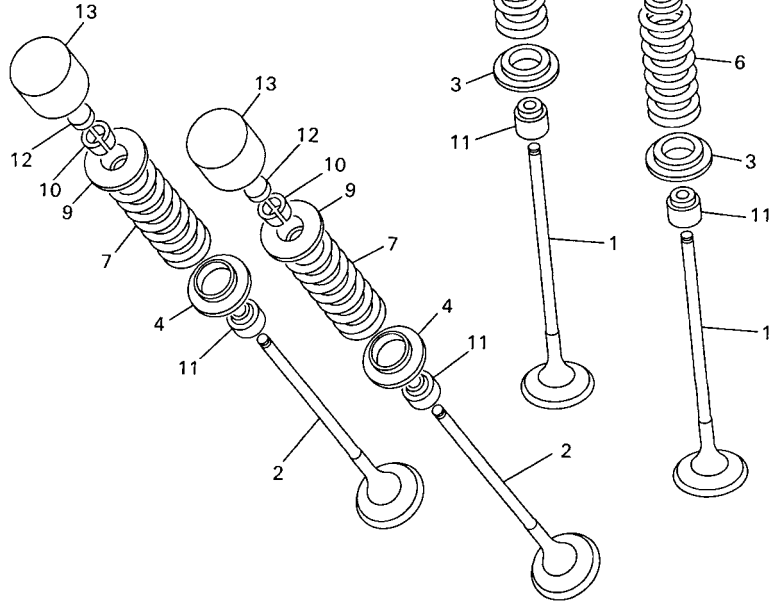

5EB3351-9030

FIG. 3 VALVE

REF. NO.	PART NO.	DESCRIPTION	5VX1	5VX2	REMARKS
12	1HX-12169-50	PAD, ADJUSTING 2 (2.00)	16	16	UR
	1HX-12169-70	PAD, ADJUSTING 2 (2.05)	16	16	UR
	1HX-12169-90	PAD, ADJUSTING 2 (2.10)	16	16	UR
	1HX-12169-E0	PAD, ADJUSTING 2 (2.15)	16	16	UR
	1HX-12169-G0	PAD, ADJUSTING 2 (2.20)	16	16	UR
	1HX-12169-J0	PAD, ADJUSTING 2 (2.25)	16	16	UR
	1HX-12169-L0	PAD, ADJUSTING 2 (2.30)	16	16	UR
	1HX-12169-N0	PAD, ADJUSTING 2 (2.35)	16	16	UR
	1HX-12169-T0	PAD, ADJUSTING 2 (2.40)	16	16	UR
13	5EB-12153-20	LIFTER, VALVE	16	16	UR BLUE
	5EB-12153-30	LIFTER, VALVE	16	16	UR RED
	5EB-12153-09	LIFTER, VALVE	16	16	AP GREEN

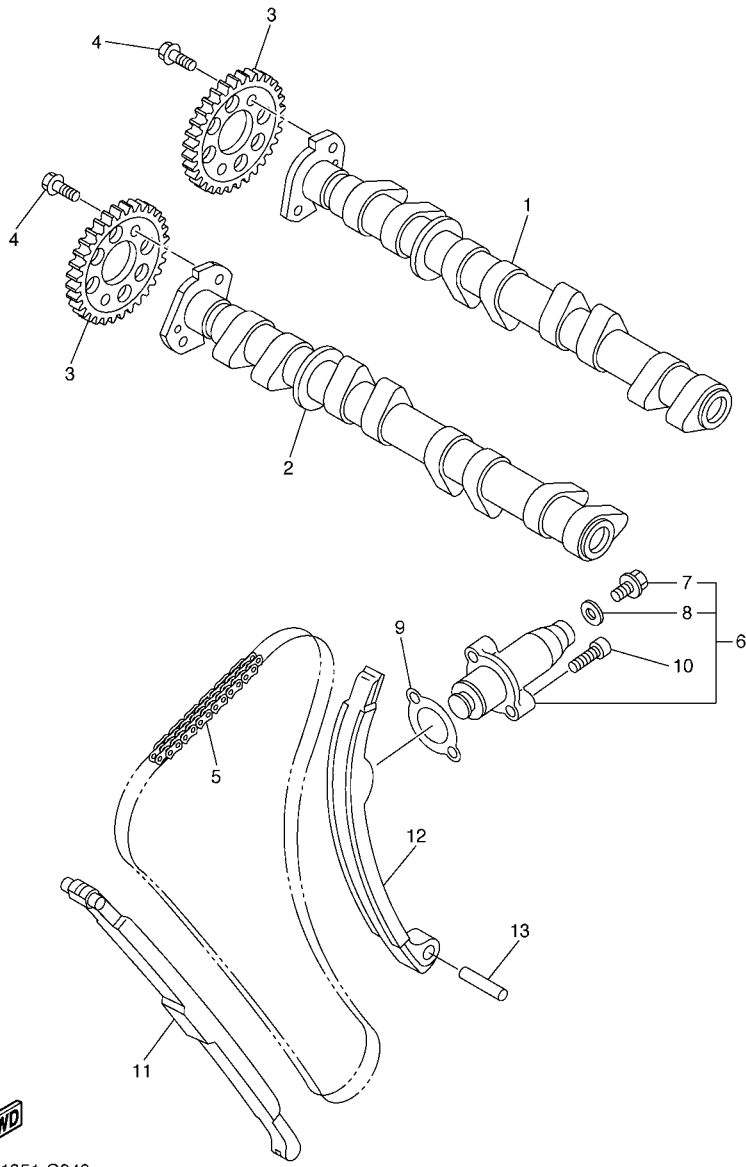
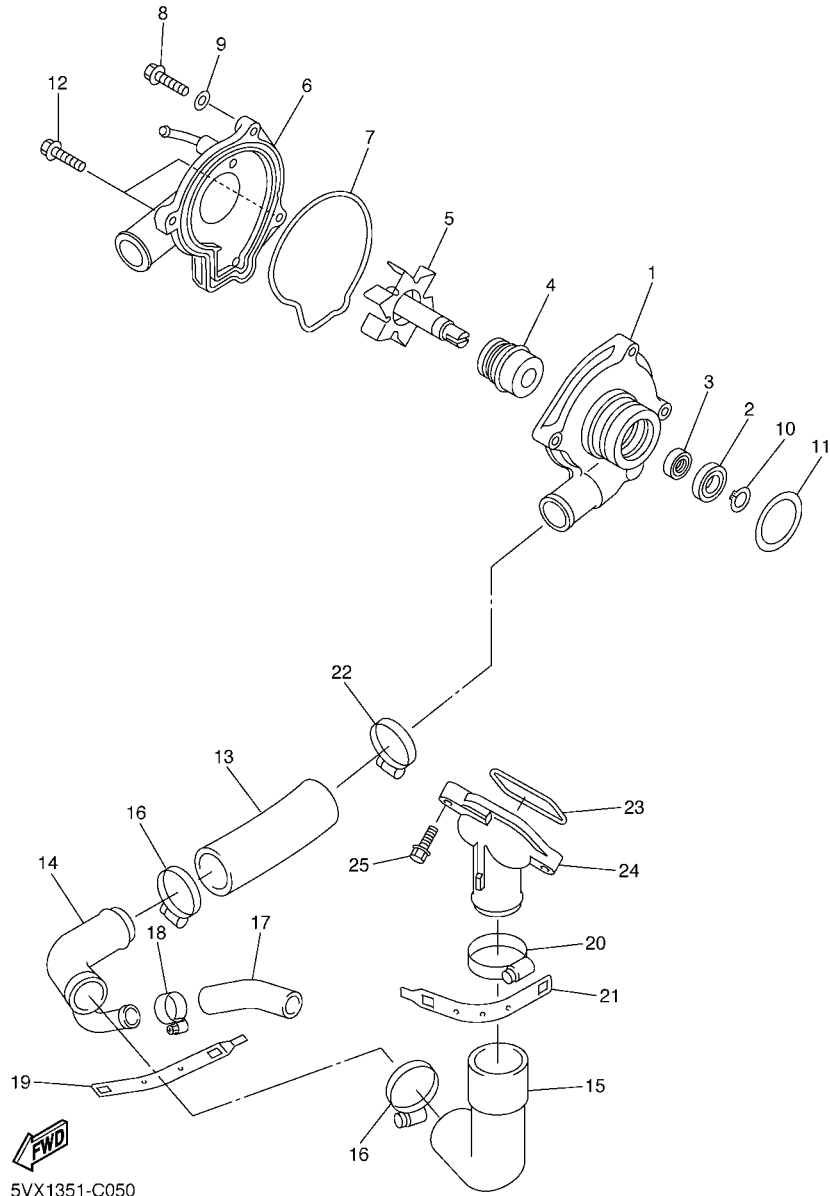

FIG. 4 CAMSHAFT & CHAIN

REF. NO.	PART NO.	DESCRIPTION	5VX1	5VX2				REMARKS
1	5VX-12170-00	CAMSHAFT ASSY 1	1	1				
2	5VX-12180-00	CAMSHAFT ASSY 2	1	1				
3	5VX-12176-00	SPROCKET, CAM CHAIN	2	2				
4	90105-07004	BOLT, FLANGE	4	4				
5	94591-49120	CHAIN	1	1				
6	5SL-12210-10	TENSIONER ASSY, CAM CHAIN	1	1				
7	5EL-12228-00	.BOLT	1	1				
8	5SL-12214-00	.GASKET	1	1				
9	4FM-12213-00	GASKET, TENSIONER CASE	1	1				
10	91314-06025	BOLT	2	2				
11	5EB-12251-00	DAMPER, CHAIN 1	1	1				
12	5EB-12252-10	DAMPER, CHAIN 2	1	1				
13	93607-44190	PIN, DOWEL	1	1				

 5VX1351-C040

FIG. 5 WATER PUMP



5VX1351-C050

REF. NO.	PART NO.	DESCRIPTION	5VX1	5VX2				REMARKS
1	5VX-12421-00	HOUSING, WATER PUMP	1	1				
2	93306-00106	BEARING	1	1				
3	93101-12173	OIL SEAL	1	1				
4	11H-12438-10	SEAL, MECHANICAL	1	1				
5	5EB-12450-00	IMPELLER SHAFT ASSY	1	1				
6	5VX-12422-00	COVER, HOUSING	1	1				
7	5EB-12439-00	O-RING	1	1				
8	95024-06020	BOLT, FLANGE	2	2				
9	90430-06014	GASKET	1	1				
10	99009-12400	CIRCLIP	1	1				
11	93210-33133	O-RING	1	1				
12	90110-06086	BOLT, HEXAGON SOCKET HEAD	2	2				
13	4NK-12579-00	HOSE 4	1	1				
14	5VX-12581-00	JOINT, HOSE 1	1	1				
15	5EB-12577-01	HOSE 2	1	1				
16	90450-35001	HOSE CLAMP ASSY	2	2				
17	5SL-12588-01	HOSE 5	1	1				
18	90450-22017	HOSE CLAMP ASSY	1	1				
19	5GV-1246E-00	COVER 2	1	1				
20	90450-38040	HOSE CLAMP ASSY	1	1				
21	5GV-1246A-00	COVER 1	1	1				
22	90450-32001	HOSE CLAMP ASSY	1	1				
23	93210-47675	O-RING	1	1				
24	5EB-12469-00	JOINT 1	1	1				
25	95024-06020	BOLT, FLANGE	2	2				

FIG. 6 RADIATOR & HOSE

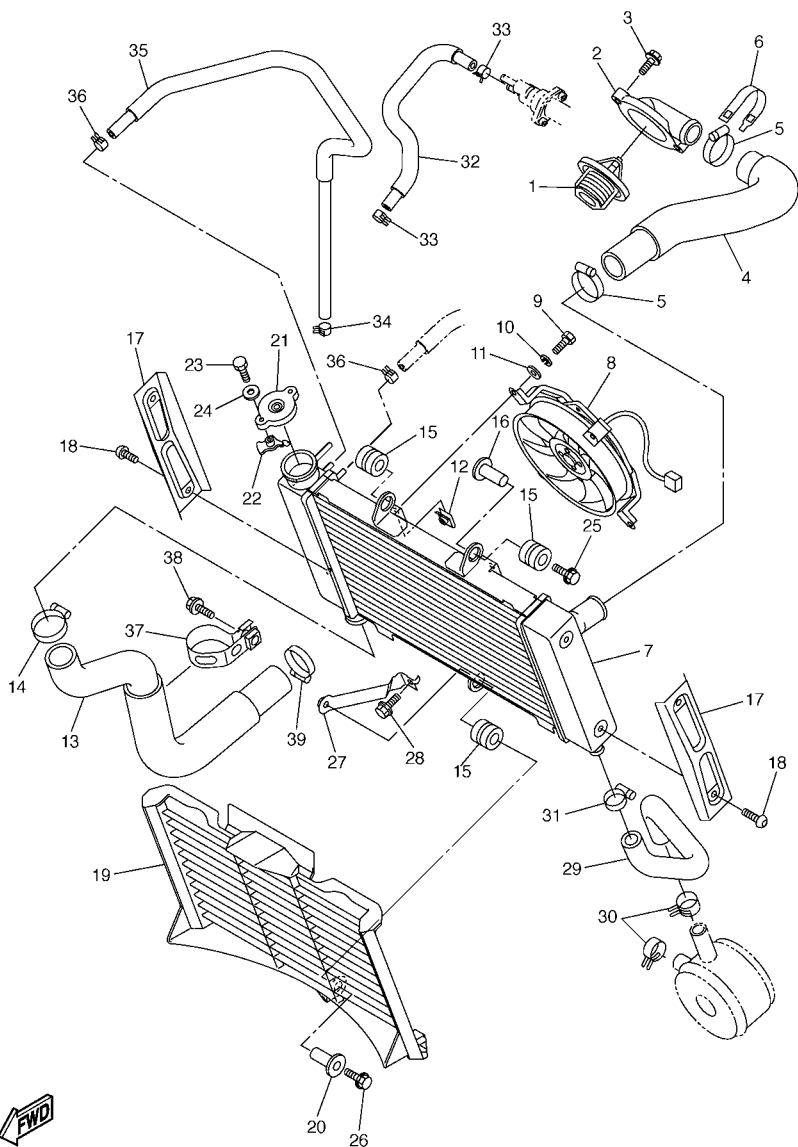

5VX1351-C060

REF. NO.	PART NO.	DESCRIPTION	5VX1	5VX2	REMARKS
1	5SL-12410-00	THERMOSTAT ASSY	1	1	
2	5VX-12413-00	COVER, THERMOSTAT	1	1	
3	90105-06557	BOLT, FLANGE	2	2	
4	5VX-12578-00	HOSE 3	1	1	
5	90450-35001	HOSE CLAMP ASSY	2	2	
6	5GV-1246E-00	COVER 2	1	1	
7	5VX-12461-00	RADIATOR ASSY	1	1	
8	5VX-12405-00	BLOWER ASSY	1	1	
9	97307-06012	BOLT	4	4	
10	92907-06100	WASHER, SPRING	4	4	
11	92907-06600	WASHER, PLATE	4	4	
12	1AA-12535-00	PLATE	4	4	
13	5VX-12579-00	HOSE 4	1	1	
14	90450-35001	HOSE CLAMP ASSY	1	1	
15	90480-15363	GROMMET	3	3	
16	90387-0614M	COLLAR	1	1	
17	5VX-1240J-00	RADIATOR COVER ASSY1	2	2	
18	90111-06016	BOLT	4	4	
19	5VX-12467-00	COVER, RADIATOR	1	1	
20	90387-066H4	COLLAR	1	1	
21	4FL-12462-00	CAP, RADIATOR	1	1	
22	1KT-12437-00	STOPPER	1	1	
23	97007-05012	BOLT	1	1	
24	92907-05600	WASHER, PLATE	1	1	
25	90119-06038	BOLT, WITH WASHER	1	1	
26	95824-06030	BOLT, FLANGE	1	1	
27	5VX-1244E-00	BRACKET 1	1	1	



5VX1351-C060

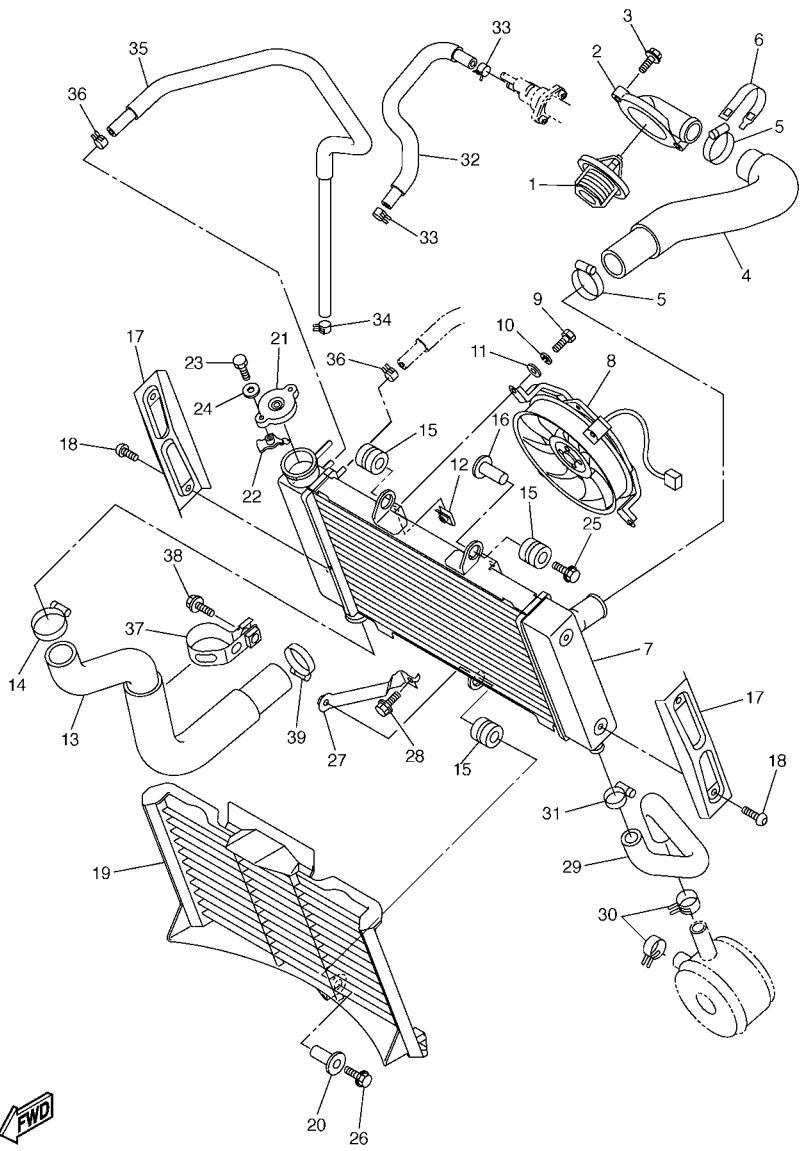
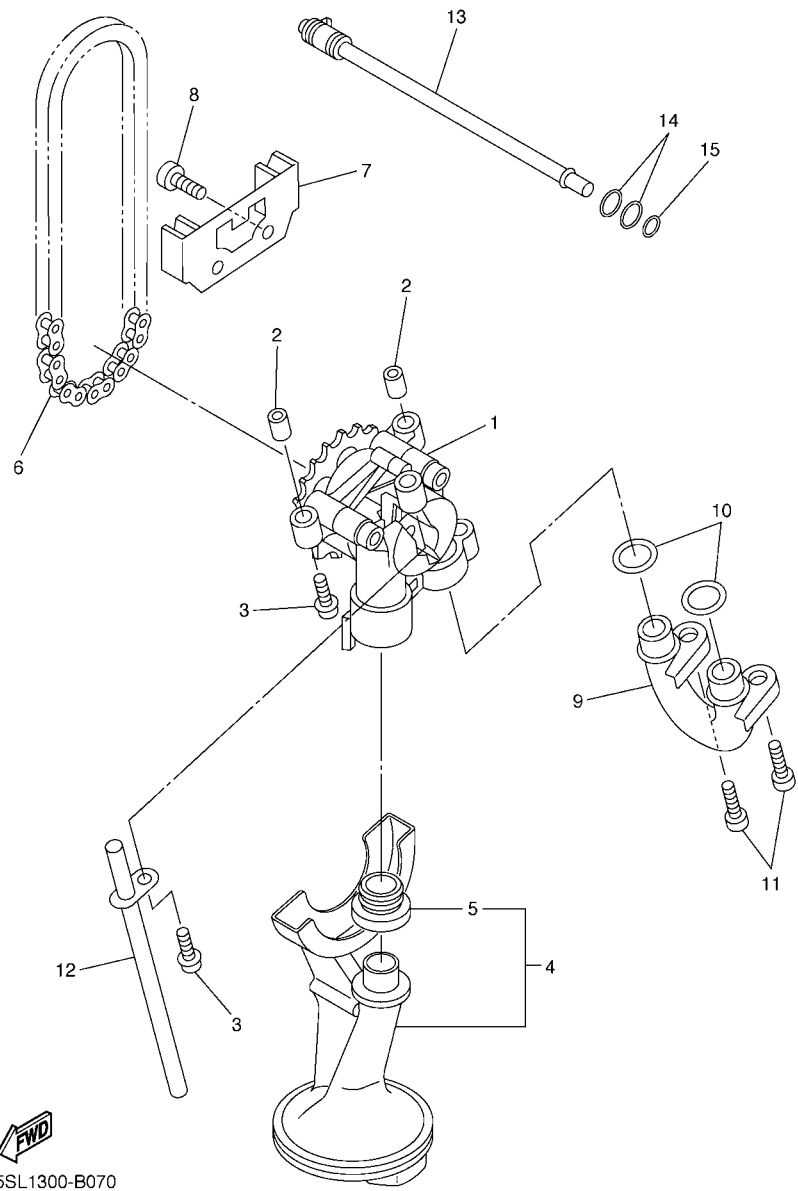

FIG. 6 RADIATOR & HOSE

REF. NO.	PART NO.	DESCRIPTION	5VX1	5VX2	REMARKS
28	95824-06012	BOLT, FLANGE	1	1	
29	5VX-12589-00	HOSE 6	1	1	
30	90467-200A0	CLIP	2	2	
31	90450-22017	HOSE CLAMP ASSY	1	1	
32	5VX-1243A-00	HOSE 1	1	1	
33	90467-11090	CLIP	2	2	
34	90467-11090	CLIP	1	1	
35	5VX-1244G-00	HOSE, 4	1	1	
36	90467-11090	CLIP	2	2	
37	5VX-12491-00	CLAMP 1	1	1	
38	95024-10020	BOLT, FLANGE	1	1	
39	90450-32001	HOSE CLAMP ASSY	1	1	



FWD
5SL1300-B070

FIG. 7 OIL PUMP

REF. NO.	PART NO.	DESCRIPTION	5VX1	5VX2	REMARKS
1	5MT-13300-00	OIL PUMP ASSY	1	1	
2	91808-17032	PIN, DOWEL	2	2	
3	90109-06031	BOLT	3	3	
4	5SL-13410-00	STRAINER HOUSING ASSY	1	1	
5	5EB-13415-00	.SEAL, OIL STRAINER	1	1	
6	94580-25080	CHAIN	1	1	
7	5EB-13898-00	HOLDER	1	1	
8	90110-06041	BOLT, HEXAGON SOCKET HEAD	2	2	
9	5JW-13416-00	PIPE, OIL 1	1	1	
10	93210-14003	O-RING	2	2	
11	90110-06041	BOLT, HEXAGON SOCKET HEAD	2	2	
12	5EB-13161-00	PIPE, DELIVERY 1	1	1	
13	5EB-1316E-00	PIPE, DELEVERY 5	1	1	
14	93210-09165	O-RING	2	2	
15	93210-06667	O-RING	1	1	

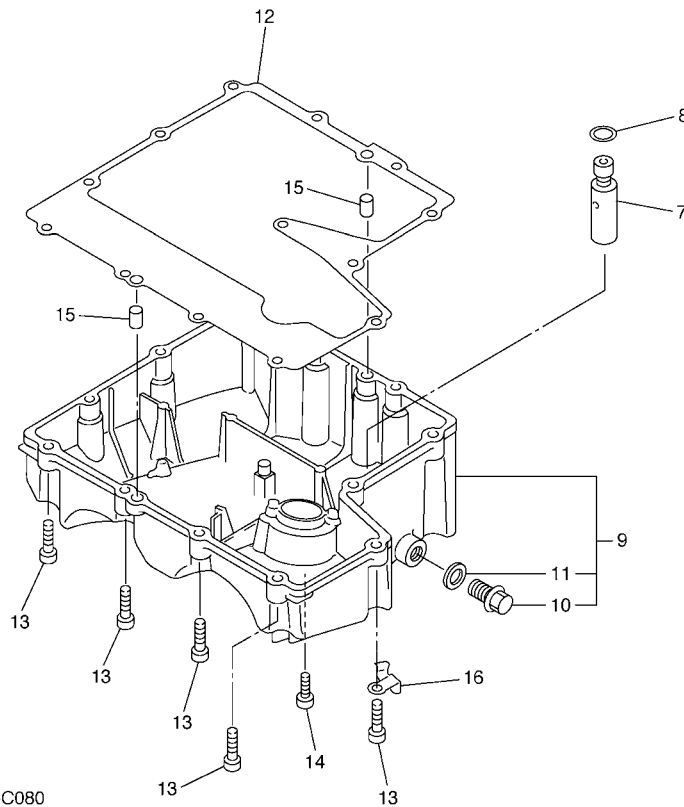
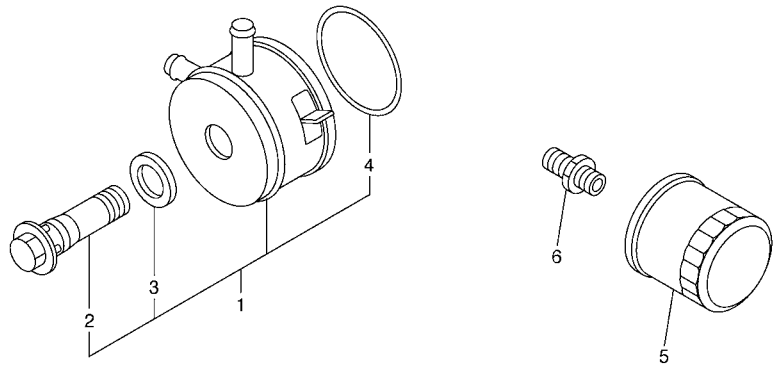



5VX1351-C080

FIG. 8 OIL CLEANER

REF. NO.	PART NO.	DESCRIPTION	5VX1	5VX2				REMARKS
1	5EB-13470-00	OIL COOLER ASSY	1	1				
2	5EB-12822-00	.BOLT, UNION	1	1				
3	5EB-13475-00	.GASKET	1	1				
4	4JH-13473-00	.O-RING	1	1				
5	5GH-13440-10	ELEMENT ASSY, OIL CLEANER	1	1				
6	90401-20145	BOLT, UNION	1	1				
7	3KS-13490-00	RELIEF VALVE ASSY	1	1				
8	93210-15566	O-RING	1	1				
9	5VX-13417-00	COVER, STRAINER	1	1				
10	90340-14132	.PLUG, STRAIGHT SCREW	1	1				
11	214-11198-01	.GASKET	1	1				
12	5VX-13414-00	GASKET, STRAINER COVER	1	1				
13	91317-06025	BOLT	12	12				
14	90110-06020	BOLT, HEXAGON SOCKET HEAD	1	1				
15	99530-08012	PIN, DOWEL	2	2				
16	90465-10030	CLAMP	1	1				

FIG. 10 INTAKE 2

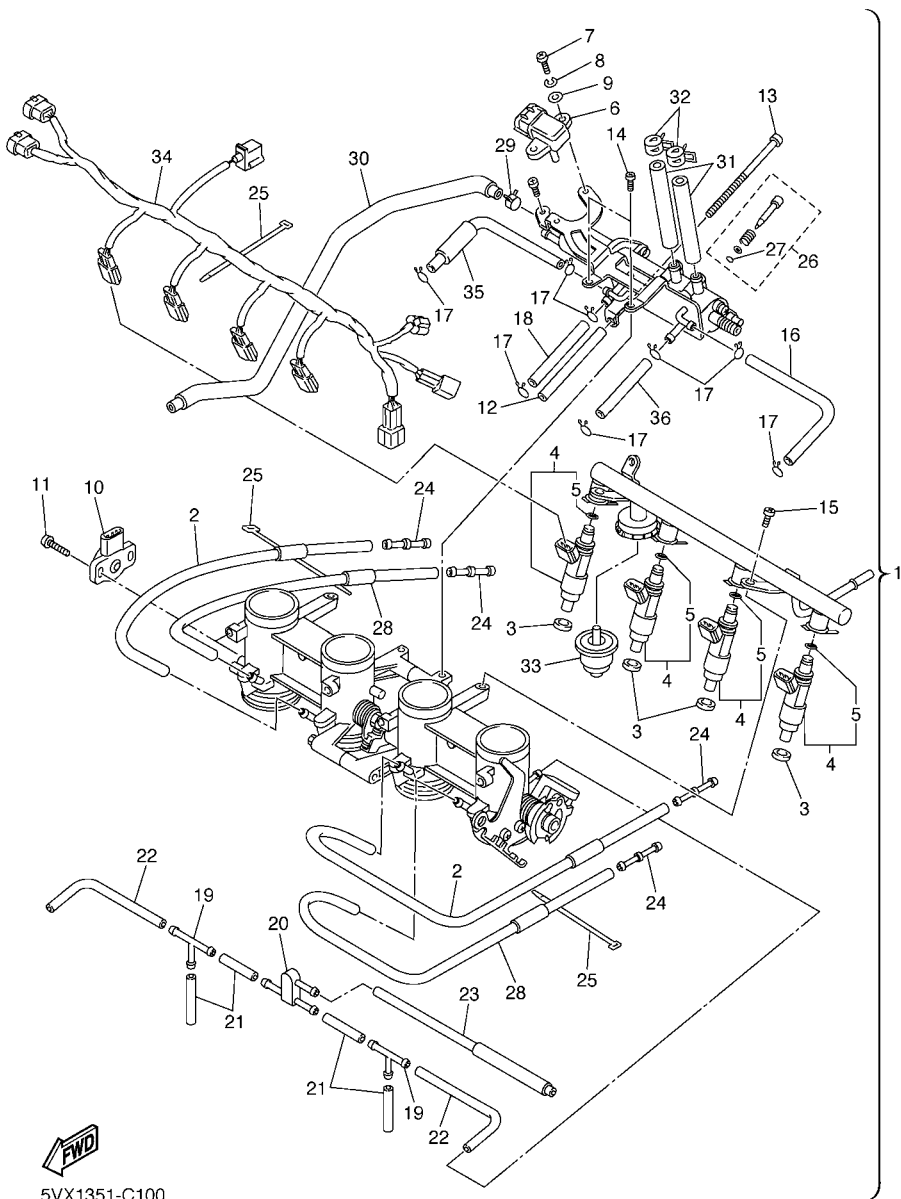
REF. NO.	PART NO.	DESCRIPTION	5VX1	5VX2	REMARKS
1	5VX-13750-00	THROTTLE BODY ASSY	1	1	
2	5VX-14348-00	.PIPE 1	2	2	
3	90430-09002	.GASKET	4	4	
4	5VX-13761-00	.INJECTOR ASSY	4	4	
5	5PS-14147-00	..O-RING	1	1	
6	5VX-82380-00	.SENSOR, PRESSURE	1	1	
7	98507-05016	.SCREW, PAN HEAD	2	2	
8	92907-05100	.WASHER, SPRING	2	2	
9	92907-05600	.WASHER, PLATE	2	2	
10	5FL-85885-01	.THROTTLE SENSOR ASSY	1	1	
11	8CC-14216-10	.SCREW	2	2	
12	5VX-14149-00	.PIPE	1	1	
13	5VX-14565-00	.SCREW	1	1	
14	98507-05010	.SCREW, PAN HEAD	2	2	
15	98507-06012	.SCREW, PAN HEAD	2	2	
16	5VX-14396-00	.PIPE	1	1	
17	3UH-14937-00	.CLIP	8	8	
18	5VX-14987-00	.HOSE	1	1	
19	68V-24376-00	.PIPE, JOINT 1	2	2	
20	3XV-14251-00	.NIPPLE	1	1	
21	5FL-14348-10	.PIPE 1	4	4	
22	68V-13533-00	.HOSE, VACUUM SENSING 4	2	2	
23	5VX-1410E-00	.HOSE	1	1	
24	5PW-14251-00	.NIPPLE	4	4	
25	4KM-14137-00	.CLIP	3	3	
26	5JW-14104-00	.AIR SCREW SET	4	4	
27	3H1-14147-00	..O-RING	1	1	



5VX1351-C100

FIG. 10 INTAKE 2

REF. NO.	PART NO.	DESCRIPTION	5VX1	5VX2	REMARKS
28	5VX-14349-00	.PIPE	2	2	
29	90467-11090	.CLIP	1	1	
30	5VX-1243E-00	.HOSE 2	1	1	
31	5VX-14148-00	.PIPE	2	2	
32	90467-17089	.CLIP	2	2	
33	5VX-13982-00	.DAMPER, FUEL	1	1	
34	5VX-82386-00	.EXTENSION, WIRE HARNESS	1	1	
35	5VX-13533-00	.HOSE, VACUUM SENSING 4	1	1	
36	5VX-14807-00	.HOSE	1	1	

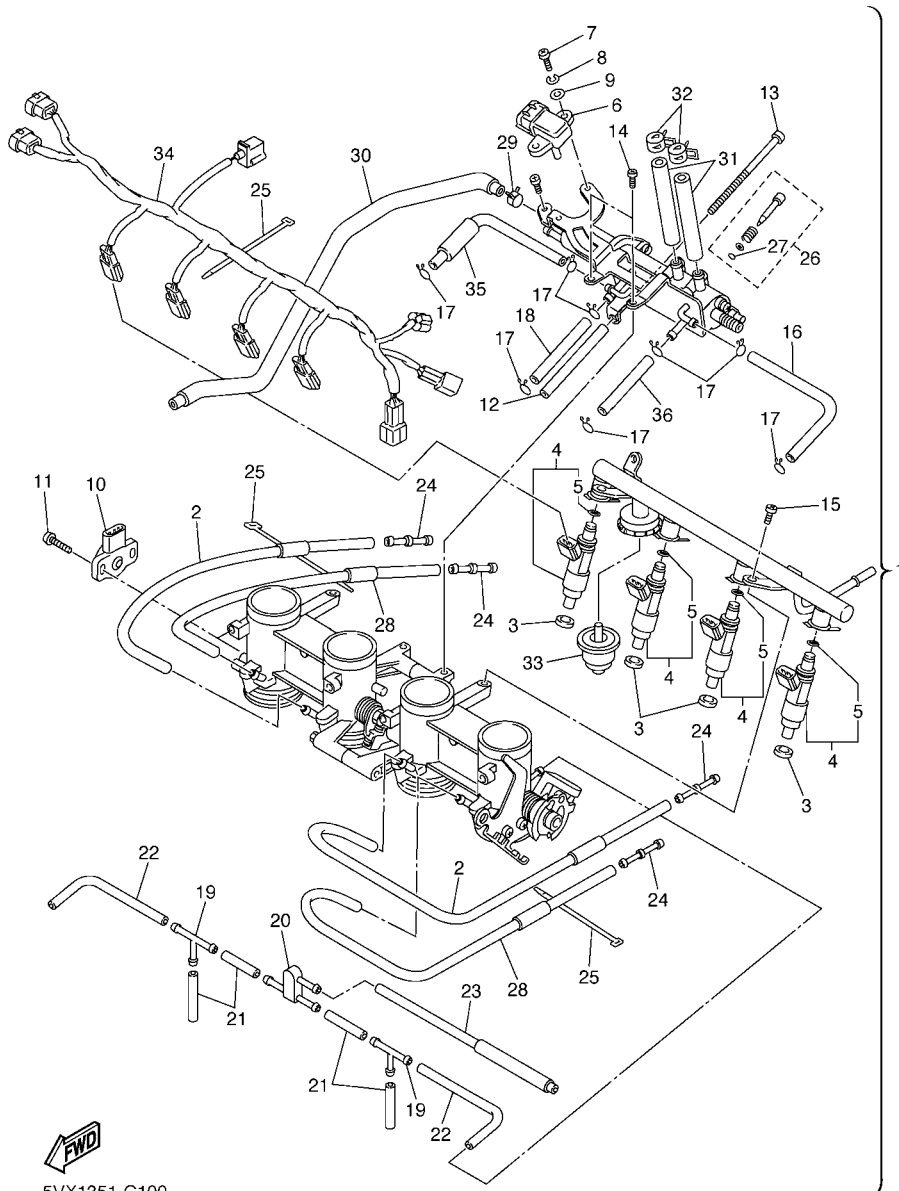

FWD
5VX1351-C100

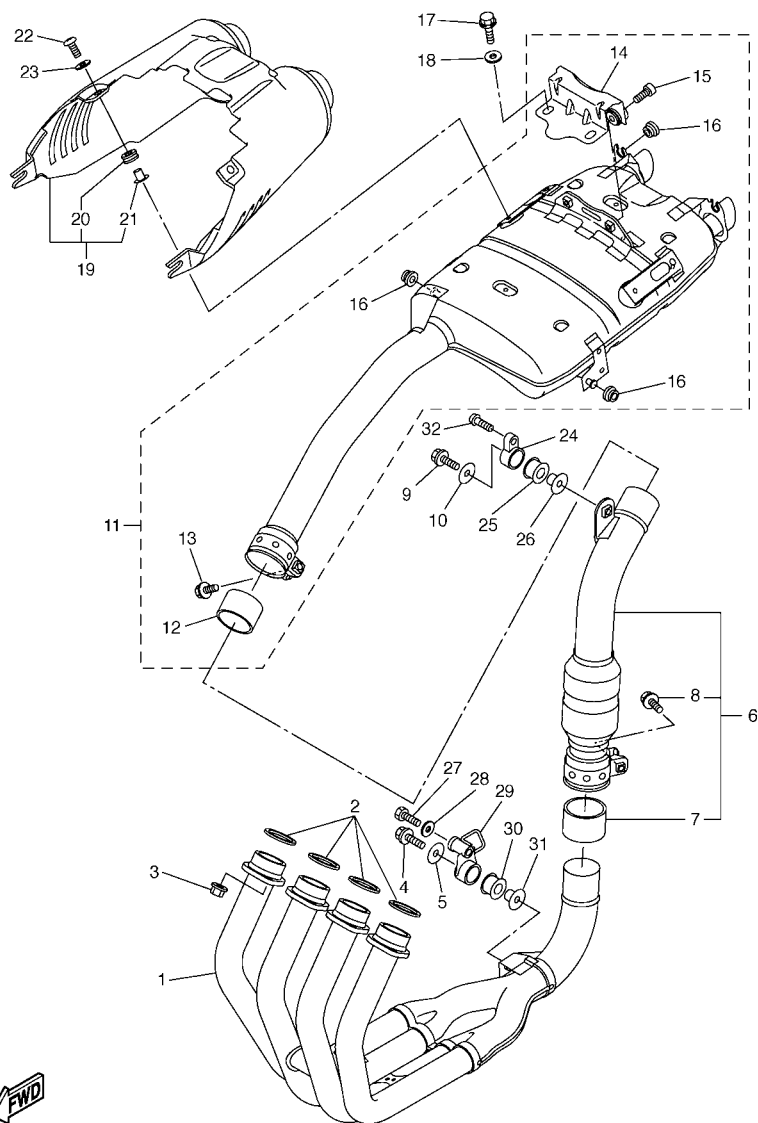

5VX1351-C120

FIG. 12 EXHAUST

REF. NO.	PART NO.	DESCRIPTION	5VX1	5VX2	REMARKS
1	5VX-14602-00	EXHAUST PIPE COMP.	1	1	
2	3YF-14613-01	GASKET, EXHAUST PIPE	4	4	
3	90179-08410	NUT	8	8	
4	95817-08035	BOLT, FLANGE	1	1	
5	90201-08612	WASHER, PLATE	1	1	
6	5VX-14740-00	CATALYST ASSY.	1	1	
7	3XW-14714-00	.GASKET, MUFFLER	1	1	
8	95814-08045	.BOLT, FLANGE	1	1	
9	95817-08035	BOLT, FLANGE	1	1	
10	90201-08612	WASHER, PLATE	1	1	
11	5VX-14710-00	MUFFLER ASSY 1	1	1	
12	5EB-14714-01	.GASKET, MUFFLER	1	1	
13	95814-08045	.BOLT, FLANGE	1	1	
14	5VX-1467K-00	.BRACKET, SILENCER 3	1	1	
15	91317-08030	.BOLT	2	2	
16	90480-10332	.GROMMET	4	4	
17	95817-08014	BOLT, FLANGE	2	2	
18	90201-086A3	WASHER, PLATE	2	2	
19	5VX-14708-10	PROTECTOR ASSY	1	1	
20	90480-12006	.GROMMET	2	2	
21	90387-061N6	.COLLAR	2	2	
22	98907-06020	SCREW, BIND	2	2	
23	4FB-14766-00	WASHER, PROTECTOR	2	2	
24	5VX-21446-10	STAY, MUFFLER 2	1	1	
25	4XV-27424-00	DAMPER, FOOTREST 2	1	1	
26	90387-082W9	COLLAR	1	1	
27	90109-082A1	BOLT	1	1	

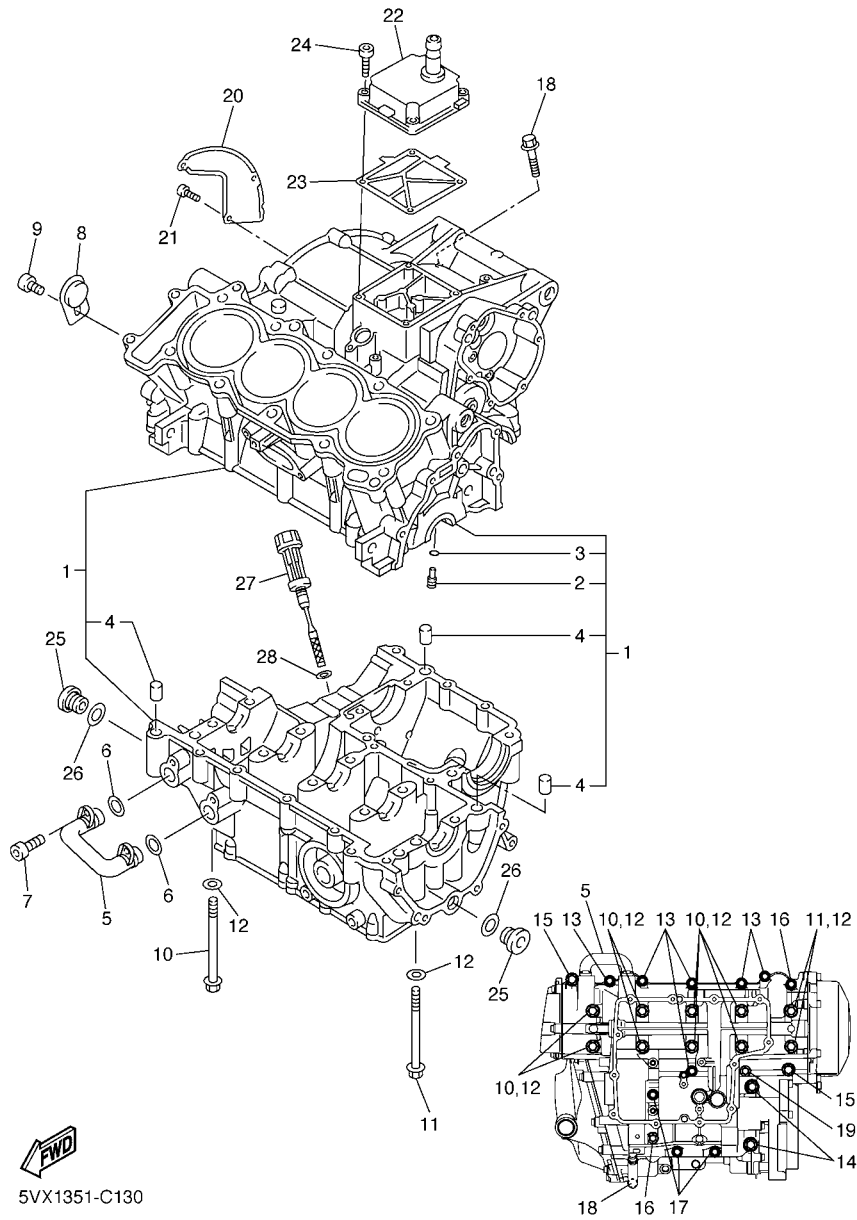

5VX1351-C130

FIG. 13 CRANKCASE

REF. NO.	PART NO.	DESCRIPTION	5VX1	5VX2	REMARKS
1	5VX-15100-00	CRANKCASE ASSY	1	1	
2	5EB-15155-00	.NOZZLE 3	4	4	
3	93210-04092	.O-RING	4	4	
4	99530-10014	.PIN, DOWEL	3	3	
5	5VX-13418-00	PIPE, OIL 2	1	1	
6	93210-14579	O-RING	2	2	
7	90110-06091	BOLT, HEXAGON SOCKET HEAD	2	2	
8	5SL-15189-00	PLUG	1	1	
9	90149-06020	SCREW	1	1	
10	90105-087A0	BOLT, FLANGE	8	8	
11	90105-086A9	BOLT, FLANGE	2	2	
12	90201-087K3	WASHER, PLATE	10	10	
13	95817-06055	BOLT, FLANGE	6	6	
14	95817-08065	BOLT, FLANGE	2	2	
15	90109-065G3	BOLT	2	2	
16	95817-06065	BOLT, FLANGE	2	2	
17	95817-06045	BOLT, FLANGE	3	3	
18	95817-06100	BOLT, FLANGE	1	1	
19	90105-06006	BOLT, FLANGE	1	1	
20	5SL-11165-00	PLATE, BREATHER	1	1	
21	90149-06020	SCREW	3	3	
22	5VX-15413-01	COVER	1	1	
23	5SL-15462-00	GASKET, CRANKCASE COVER 3	1	1	
24	91314-06025	BOLT	4	4	
25	36Y-15189-00	PLUG	2	2	
26	93210-16325	O-RING	2	2	
27	5EB-15362-00	PLUG, OIL LEVEL	1	1	

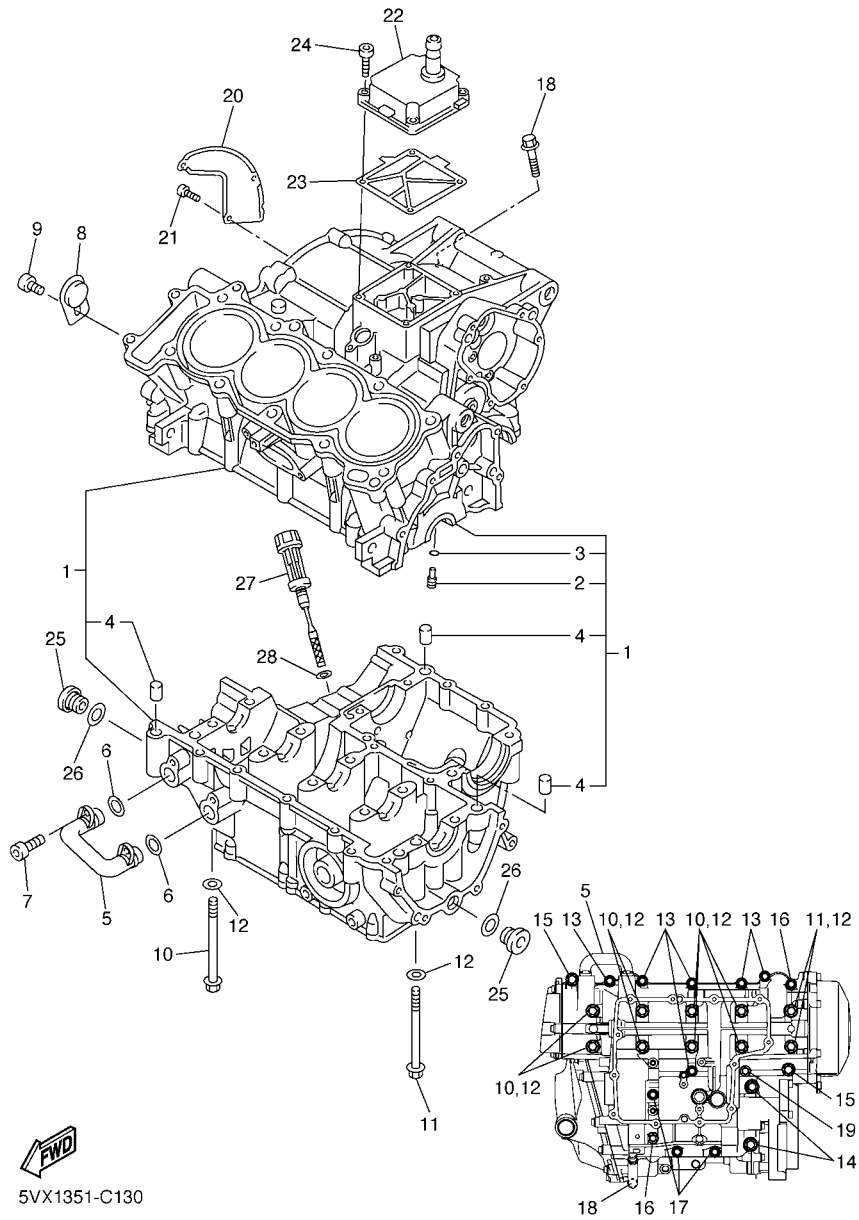

FWD
5VX1351-C130

FIG. 13 CRANKCASE

REF. NO.	PART NO.	DESCRIPTION	5VX1	5VX2		REMARKS
28	93210-09165	O-RING	1	1		

FIG. 14 CRANKCASE COVER 1

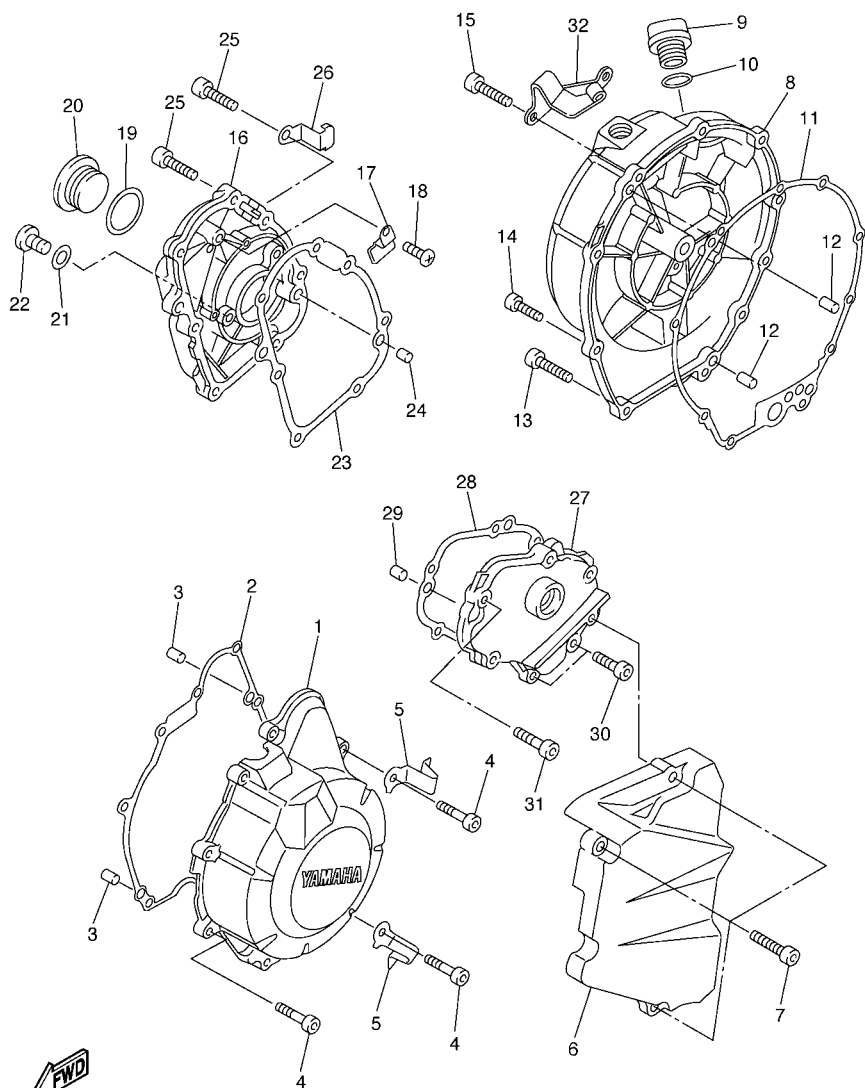

5VX1351-C140

REF. NO.	PART NO.	DESCRIPTION	5VX1	5VX2	REMARKS
1	5VX-15411-00	COVER, CRANKCASE 1	1	1	
2	5VX-15451-00	GASKET, CRANKCASE COVER 1	1	1	
3	99530-08012	PIN, DOWEL	2	2	
4	91314-06025	BOLT	9	9	
5	90465-08045	CLAMP	2	2	
6	5VX-15418-00	COVER, CHAIN CASE	1	1	
7	91314-06025	BOLT	3	3	
8	5VX-15421-00	COVER, CRANKCASE 2	1	1	
9	3F9-15362-00	PLUG, OIL LEVEL	1	1	
10	93210-27194	O-RING	1	1	
11	5SL-15461-00	GASKET, CRANKCASE COVER 2	1	1	
12	93608-17263	PIN, DOWEL	2	2	
13	91314-06025	BOLT	7	7	
14	90110-06022	BOLT, HEXAGON SOCKET HEAD	1	1	
15	91314-06030	BOLT	2	2	
16	5VX-15416-00	COVER, OIL PUMP	1	1	
17	90465-14011	CLAMP	1	1	
18	98507-06012	SCREW, PAN HEAD	1	1	
19	93210-32172	O-RING	1	1	
20	90340-32116	PLUG, STRAIGHT SCREW	1	1	
21	90430-08143	GASKET	1	1	
22	92014-08014	BOLT, BUTTON HEAD	1	1	
23	5SL-15456-00	GASKET, OIL PUMP COVER 1	1	1	
24	99530-08012	PIN, DOWEL	2	2	
25	91314-06020	BOLT	7	7	
26	90465-10035	CLAMP	1	1	
27	5VX-15425-00	COVER, GENERATOR 2	1	1	

FIG. 15 STARTER

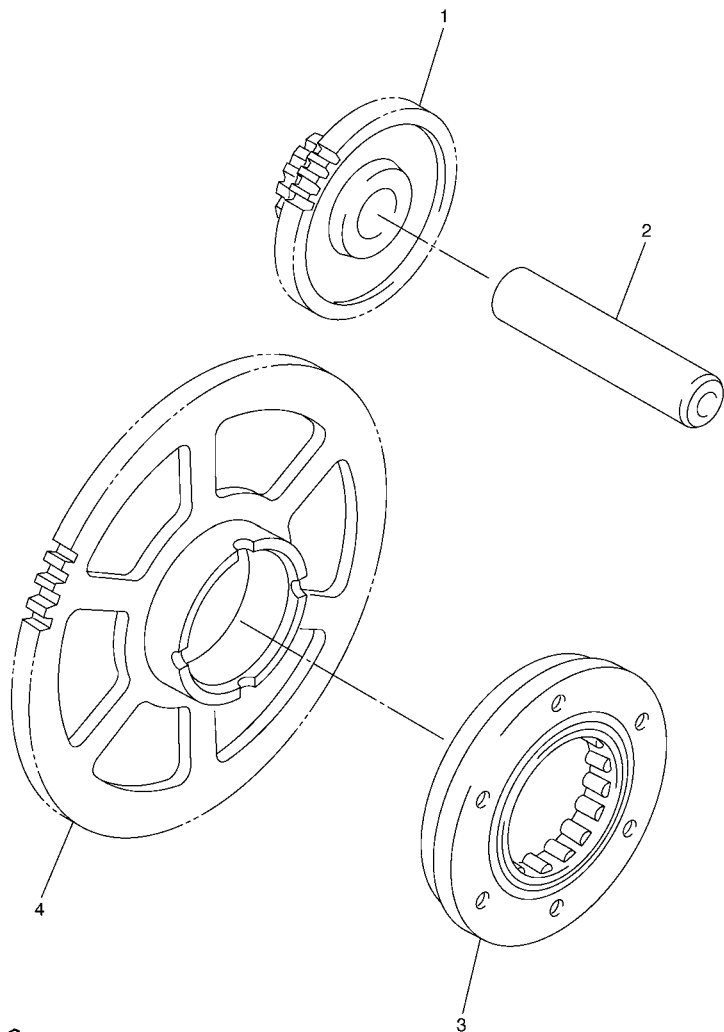

REF. NO.	PART NO.	DESCRIPTION	5VX1	5VX2				REMARKS
1	5SL-15512-00	GEAR, IDLER 1	1	1				
2	5EB-15521-00	SHAFT 1	1	1				
3	5SL-15590-00	STARTER ONE-WAY ASSY	1	1				
4	5MT-15515-00	GEAR 3	1	1				

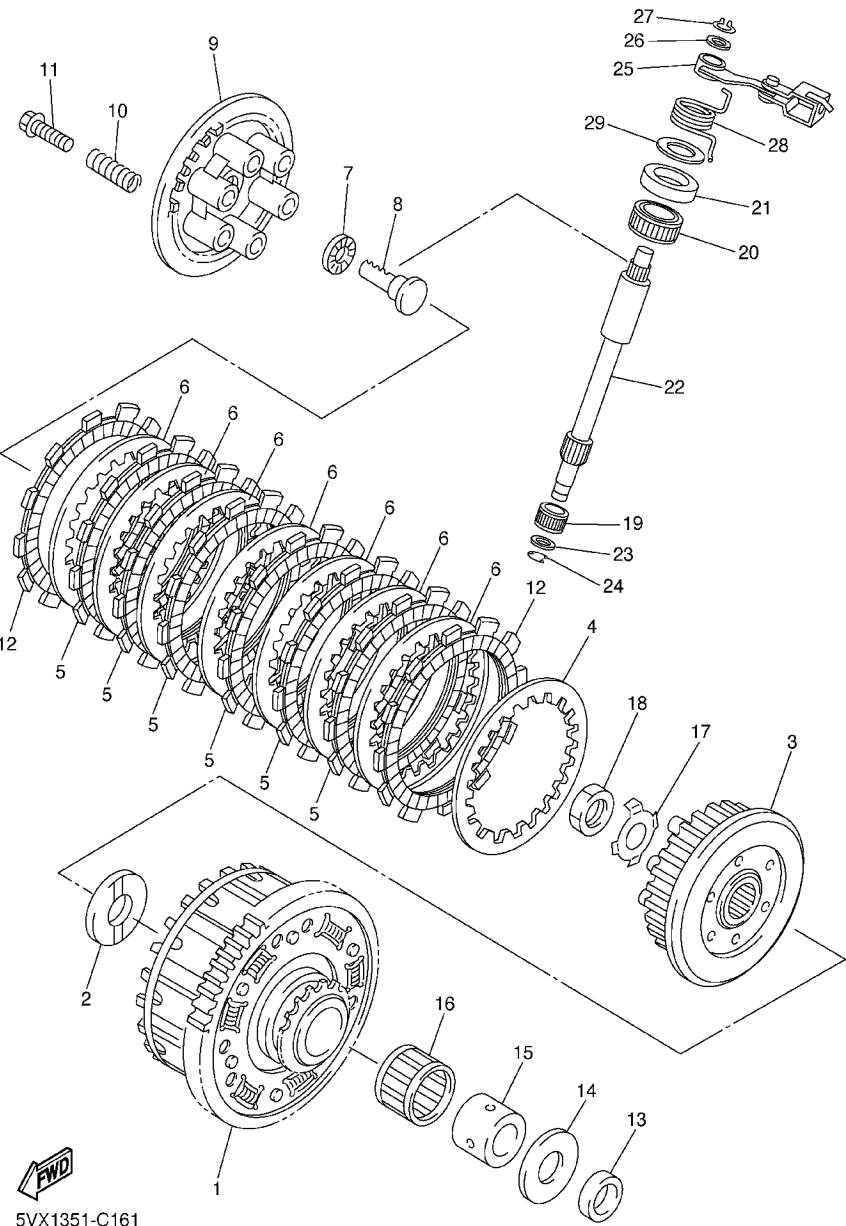

5SL1300-B150



5VX1351-C161

FIG. 16 CLUTCH

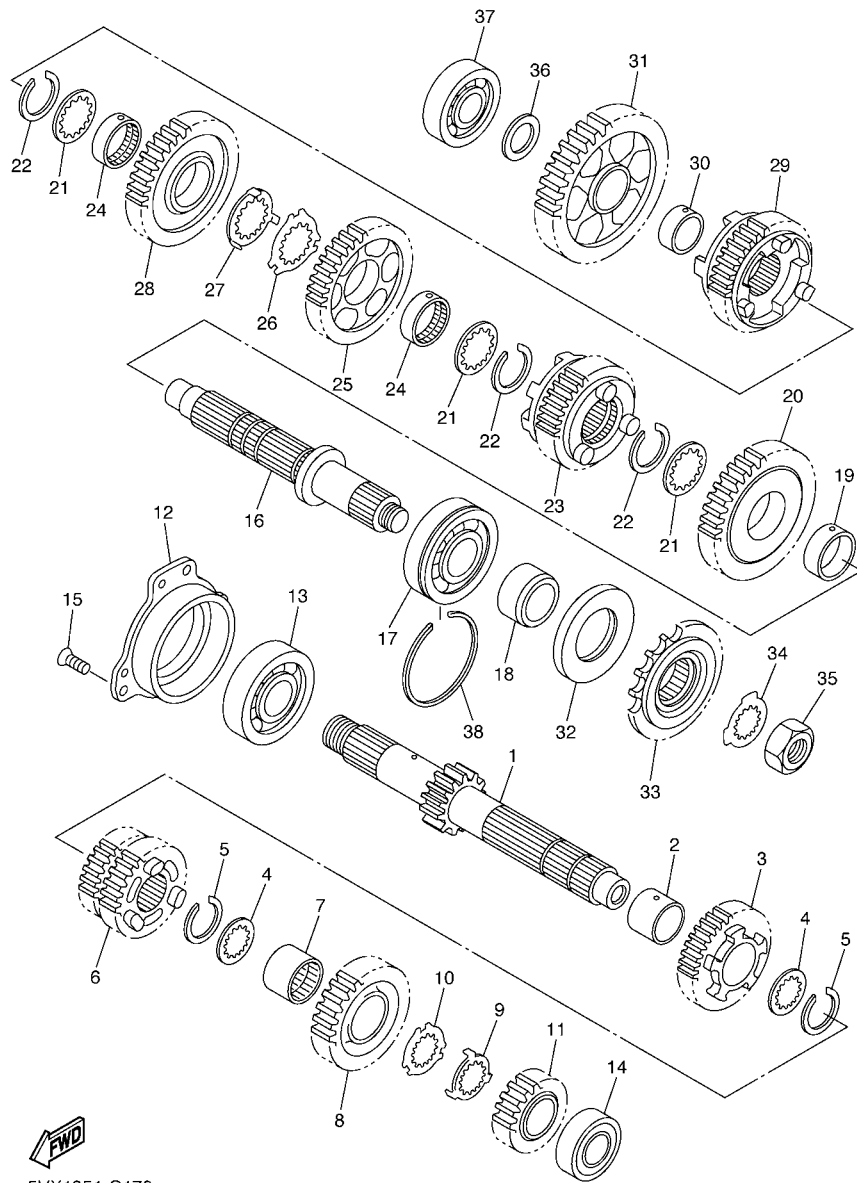
REF. NO.	PART NO.	DESCRIPTION	5VX1	5VX2	REMARKS
1	5VX-16150-00	PRIMARY DRIVEN GEAR COMP.	1	1	
2	5EB-16154-00	PLATE, THRUST 1	1	1	
3	5VX-16371-00	BOSS, CLUTCH	1	1	
4	168-16324-00	PLATE, CLUTCH 1 (T=2.3)	1	1	
5	4FN-16321-00	PLATE, FRICTION	6	6	
6	3J2-16324-00	PLATE, CLUTCH 1 (T=2.0)	7	7	
7	93306-00304	BEARING (B6003C4)	1	1	
8	5EB-16356-01	ROD, PUSH 1	1	1	
9	5EB-16351-01	PLATE, PRESSURE 1	1	1	
10	90501-225A9	SPRING, COMPRESSION	6	6	
11	90159-06002	SCREW, WITH WASHER	6	6	
12	4H7-16321-02	PLATE, FRICTION	2	2	
13	90201-255A6	WASHER, PLATE	1	1	
14	1AE-16164-00	PLATE, THRUST 2	1	1	
15	90387-25010	COLLAR	1	1	
16	93310-340N8	BEARING	1	1	
17	90215-20004	WASHER, LOCK	1	1	
18	90170-20008	NUT	1	1	
19	93317-11020	BEARING	1	1	
20	93315-31502	BEARING	1	1	
21	93102-15212	OIL SEAL	1	1	
22	5VX-16382-00	AXLE, PUSH LEVER	1	1	
23	92907-08600	WASHER, PLATE	1	1	
24	99001-07600	CIRCLIP	1	1	
25	5VX-16340-00	PUSH LEVER ASSY	1	1	
26	90201-10119	WASHER, PLATE	1	1	
27	99009-10400	CIRCLIP	1	1	



5VX1351-C170

FIG. 17 TRANSMISSION

REF. NO.	PART NO.	DESCRIPTION	5VX1	5VX2	REMARKS
1	5SL-17411-00	AXLE, MAIN (13T)	1	1	
2	90387-253M6	COLLAR	1	1	
3	5VX-17151-00	GEAR, 5TH PINION (21T)	1	1	
4	90209-21332	WASHER	2	2	
5	93440-25084	CIRCLIP	2	2	
6	5SL-17131-20	GEAR, 3RD PINION (18T/24T)	1	1	
7	90387-2513E	COLLAR	1	1	
8	5SL-17161-00	GEAR, 6TH PINION (24T)	1	1	
9	90209-22352	WASHER	1	1	
10	90209-21351	WASHER	1	1	
11	5SL-17121-00	GEAR, 2ND PINION (19T)	1	1	
12	5EB-15163-01	HOUSING, BEARING 1	1	1	
13	93306-30525	BEARING (B6305)	1	1	
14	93306-20464	BEARING	1	1	
15	90151-06008	SCREW, COUNTERSUNK	3	3	
16	5SL-17421-00	AXLE, DRIVE	1	1	
17	93306-30546	BEARING (B6305A5 SPECIAL)	1	1	
18	90387-2504A	COLLAR	1	1	
19	90387-2813C	COLLAR	1	1	
20	5VX-17221-00	GEAR, 2ND WHEEL (37T)	1	1	
21	90209-25342	WASHER	3	3	
22	93440-28062	CIRCLIP	3	3	
23	5VX-17261-00	GEAR, 6TH WHEEL (26T)	1	1	
24	90387-2813D	COLLAR	2	2	
25	5SL-17241-00	GEAR, 4TH WHEEL (32T)	1	1	
26	90209-25349	WASHER	1	1	
27	90209-25350	WASHER	1	1	

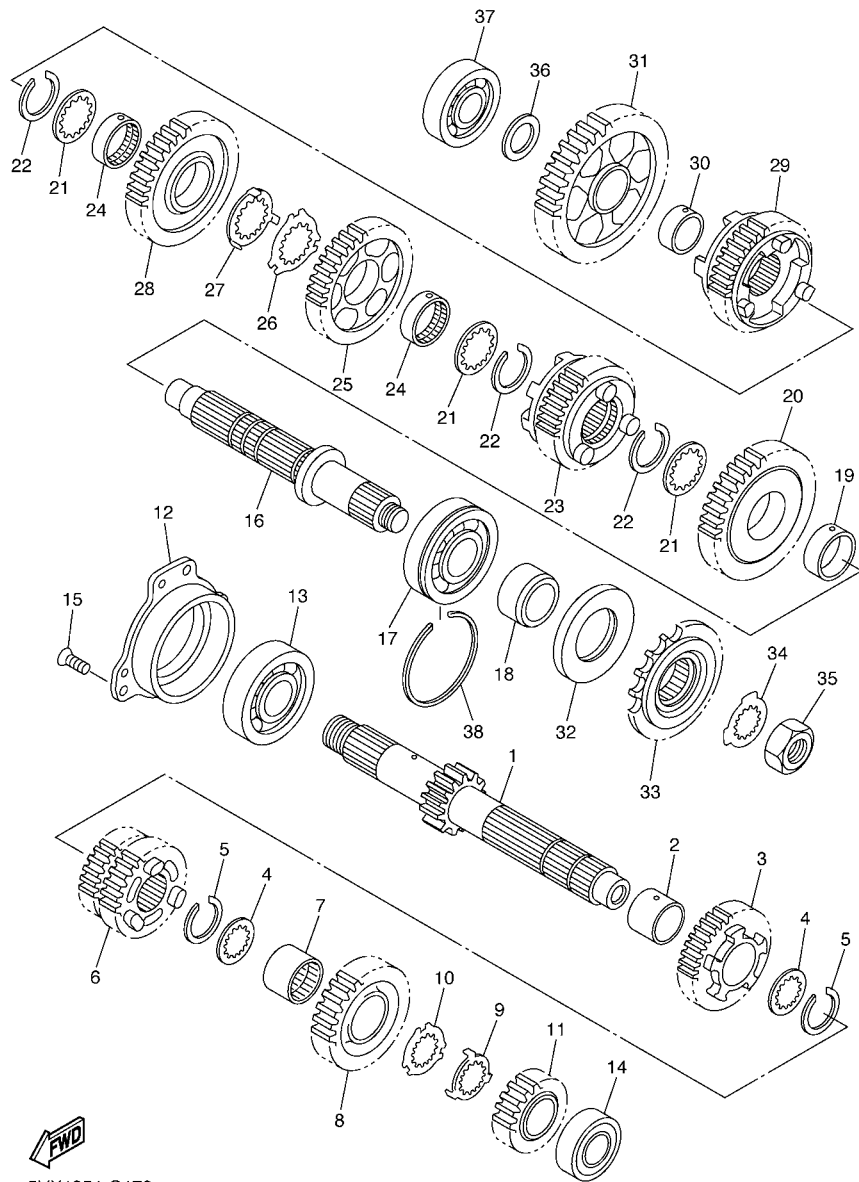

5VX1351-C170

FIG. 17 TRANSMISSION

REF. NO.	PART NO.	DESCRIPTION	5VX1	5VX2	REMARKS
28	5SL-17231-00	GEAR, 3RD WHEEL (28T)	1	1	
29	5VX-17251-00	GEAR, 5TH WHEEL (25T)	1	1	
30	90387-2202V	COLLAR	1	1	
31	5SL-17211-00	GEAR, 1ST WHEEL (37T)	1	1	
32	93102-35423	OIL SEAL	1	1	
33	5VX-17460-00	SPROCKET, DRIVE (16T)	1	1	
34	90215-21290	WASHER, LOCK	1	1	
35	90179-18667	NUT	1	1	
36	90201-20278	WASHER, PLATE	1	1	
37	93306-20464	BEARING	1	1	
38	278-17424-01	CIRCLIP 1	1	1	

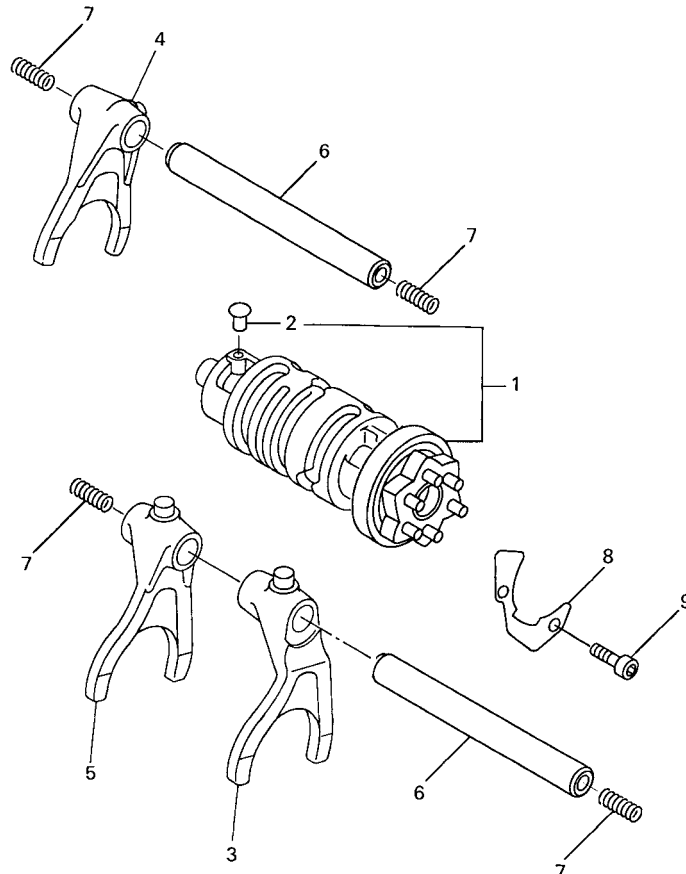

FIG. 18 SHIFT CAM & FORK

REF. NO.	PART NO.	DESCRIPTION	5VX1	5VX2				REMARKS
1	5VX-18540-00	SHIFT CAM ASSY	1	1				
2	136-18542-00	.POINT, NEUTRAL	1	1				
3	5SL-18511-00	FORK, SHIFT 1	1	1				
4	5MT-18512-00	FORK, SHIFT 2	1	1				
5	5EB-18513-00	FORK, SHIFT 3	1	1				
6	4XV-18531-00	BAR, SHIFT FORK GUIDE 1	2	2				
7	90501-064L1	SPRING, COMPRESSION	4	4				
8	5EB-18536-00	STOPPER, SHIFT BAR	1	1				
9	90110-06018	BOLT, HEXAGON SOCKET HEAD	2	2				



5EB3351-9170

FIG. 19 SHIFT SHAFT

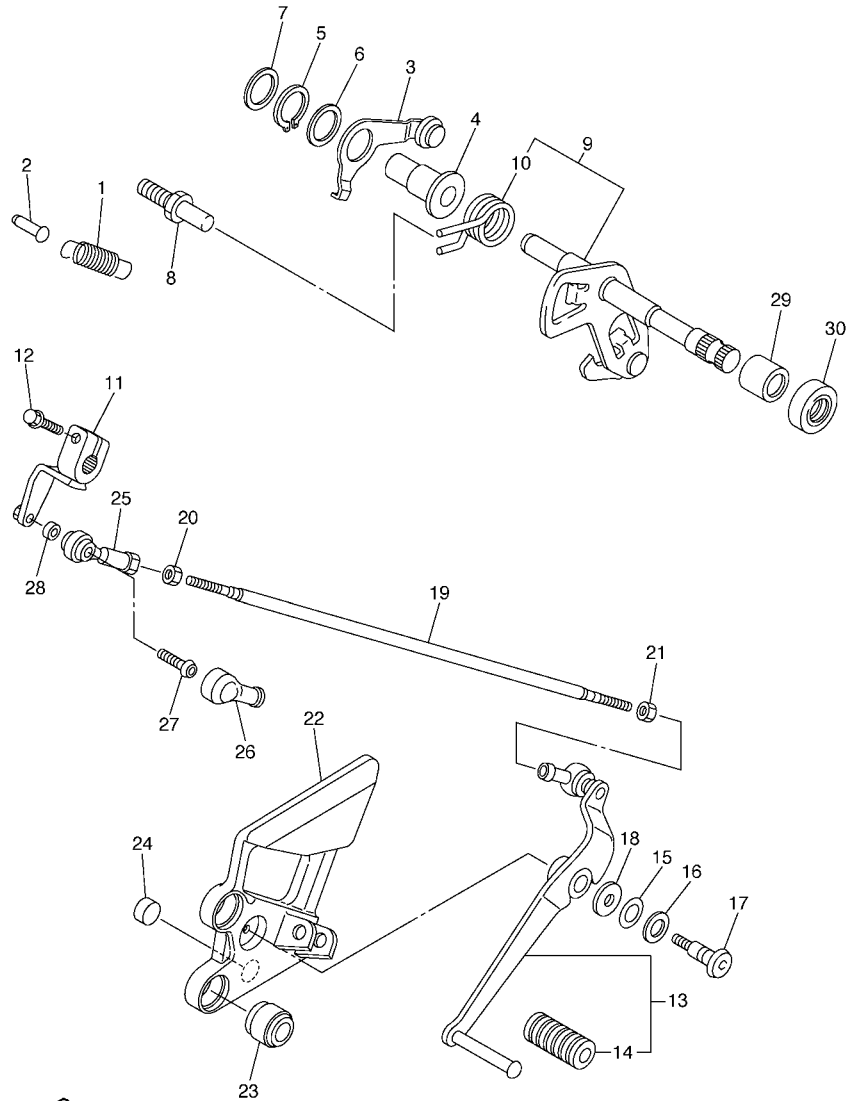

5VX1351-C190

REF. NO.	PART NO.	DESCRIPTION	5VX1	5VX2	REMARKS
1	90506-14003	SPRING, TENSION	1	1	
2	132-16346-00	HOOK, SPRING	1	1	
3	5VX-18140-00	STOPPER LEVER ASSY	1	1	
4	90387-127V3	COLLAR	1	1	
5	99009-17400	CIRCLIP	1	1	
6	90201-177G4	WASHER, PLATE	1	1	
7	90201-154E8	WASHER, PLATE (T=1.0)	1	1	
8	4XV-18127-00	STOPPER, SCREW	1	1	
9	5VX-18101-10	SHIFT SHAFT ASSY	1	1	
10	90508-295B2	.SPRING, TORSION	1	1	
11	5VX-18112-00	ARM, SHIFT	1	1	
12	95824-06020	BOLT, FLANGE	1	1	
13	5VX-18110-00	SHIFT PEDAL ASSY	1	1	
14	5EB-18113-00	.COVER, SHIFT PEDAL	1	1	
15	90201-12013	WASHER, PLATE	1	1	
16	90206-12074	WASHER, WAVE	1	1	
17	4BP-27434-01	BOLT	1	1	
18	90201-08784	WASHER, PLATE	1	1	
19	5VX-18115-00	ROD, SHIFT	1	1	
20	90170-06228	NUT(COUNTER CLOCKWISE)	1	1	
21	95304-06700	NUT	1	1	
22	5VX-27442-00	BRACKET 2	1	1	
23	5VX-27424-00	DAMPER, FOOTREST 2	2	2	
24	5VX-27114-00	STOPPER, MAIN STAND	1	1	
25	5VX-18116-00	JOINT, ROD 1	1	1	
26	5VX-18154-00	COVER, DUST	1	1	
27	90111-06019	BOLT	1	1	

FIG. 19 SHIFT SHAFT

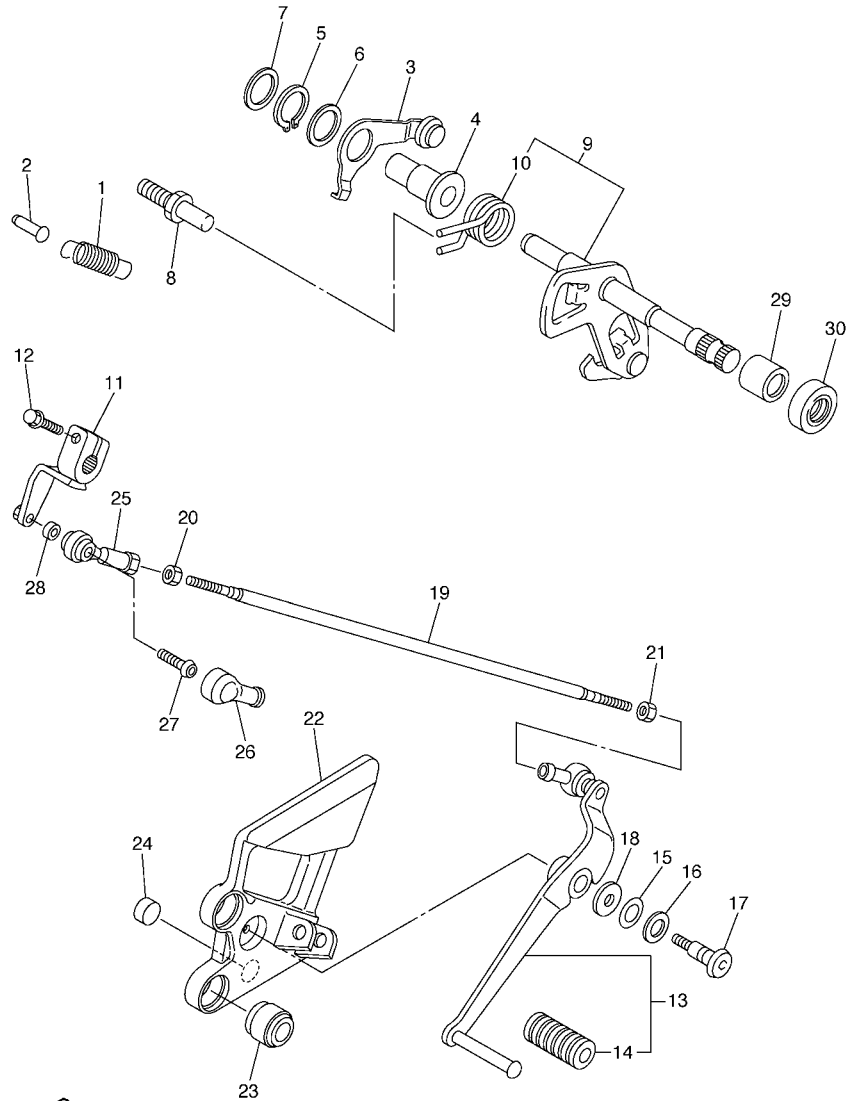

REF. NO.	PART NO.	DESCRIPTION	5VX1	5VX2				REMARKS
28	90387-06372	COLLAR	1	1				
29	93317-11287	BEARING	1	1				
30	93101-12004	OIL SEAL	1	1				



5VX1351-C190

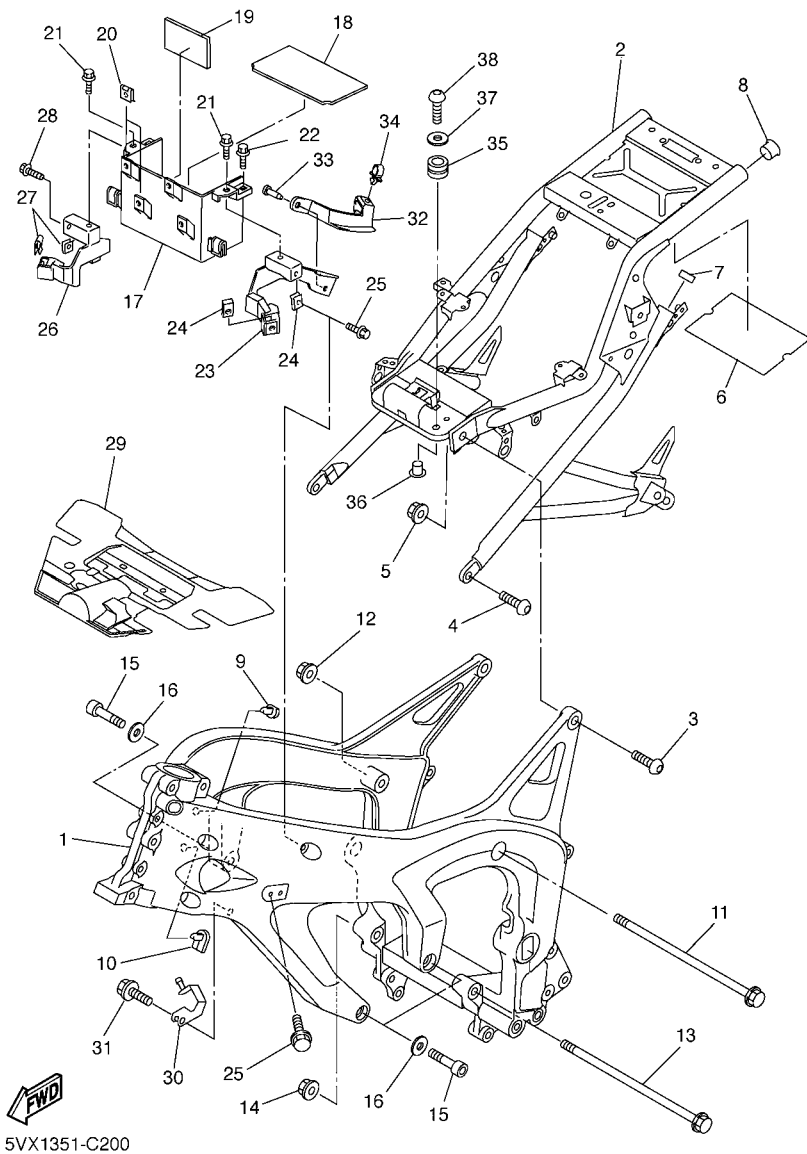

5VX1351-C200

FIG. 20 FRAME

REF. NO.	PART NO.	DESCRIPTION	5VX1	5VX2	REMARKS
1	5VX-21110-00	FRAME COMP.	1		
	5VX-21110-10	FRAME COMP.		1	
2	5VX-21190-00	REAR FRAME COMP.	1	1	
3	90149-10006	SCREW	2	2	
4	90149-10012	SCREW	2	2	
5	95607-10200	NUT, SELF-LOCKING	2	2	
6	5VX-21268-00	SEAL	1	1	
7	3YJ-24481-00	PLUG	2	2	
8	90338-21145	PLUG	1	1	
9	5VX-21279-00	PLUG, BLIND	1	1	
10	5VX-21289-00	PLUG, BLIND	1	1	
11	90105-10032	BOLT, FLANGE	1	1	
12	90185-10002	NUT, SELF-LOCKING	1	1	
13	90105-10N53	BOLT, FLANGE	1	1	
14	90185-10002	NUT, SELF-LOCKING	1	1	
15	91314-10050	BOLT	3	3	
16	90201-10020	WASHER, PLATE	3	3	
17	5VX-2177G-00	BOX, BATTERY	1	1	
18	5VX-82122-00	SEAT, BATTERY	1	1	
19	5EJ-2414H-00	DAMPER, PLATE 1	1	1	
20	90183-06053	NUT, SPRING	2	2	
21	90109-06060	BOLT	2	2	
22	95807-06025	BOLT, FLANGE	2	2	
23	5VX-21238-00	BRACKET	1	1	
24	90183-060A1	NUT, SPRING	2	2	
25	90105-06557	BOLT, FLANGE	2	2	
26	5VX-21239-00	BRACKET 2	1	1	

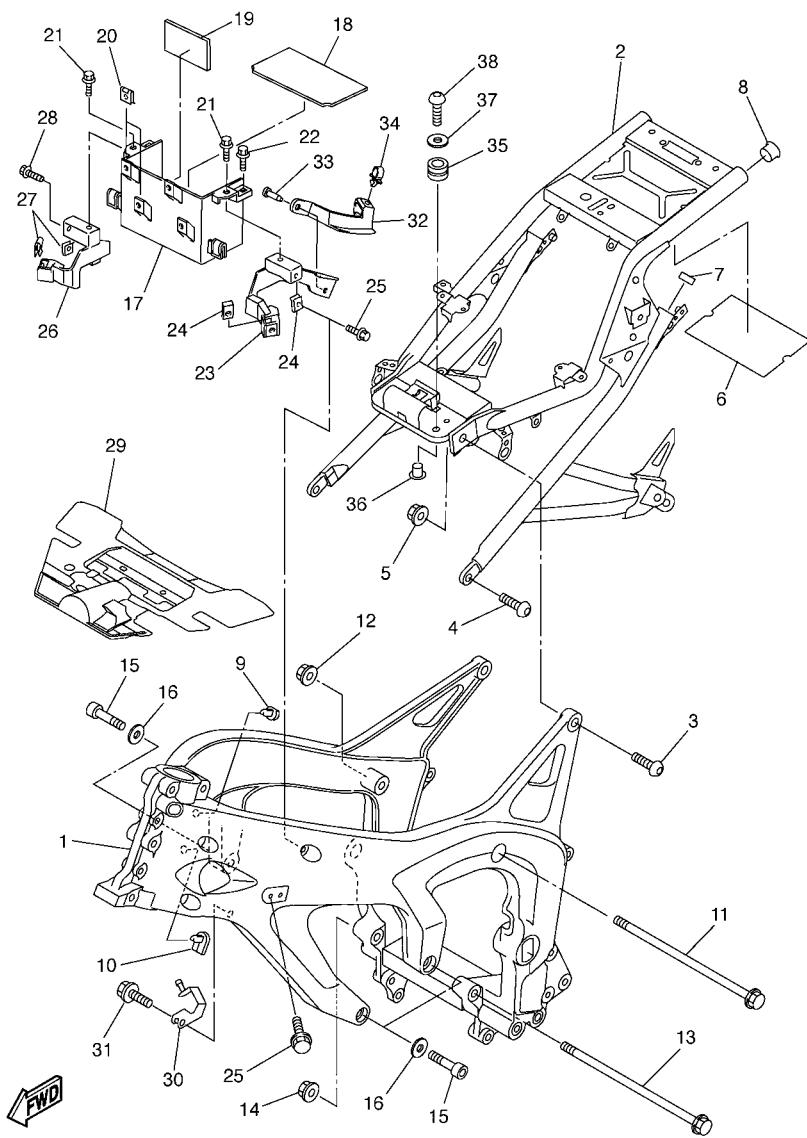

5VX1351-C200

FIG. 20 FRAME

REF. NO.	PART NO.	DESCRIPTION	5VX1	5VX2		REMARKS
27	90183-060A1	NUT, SPRING	2	2		
28	90105-06557	BOLT, FLANGE	2	2		
29	5VX-2117M-01	COVER 2	1	1		
30	5VX-21249-00	BRACKET	1	1		
31	95027-06012	BOLT, FLANGE	1	1		
32	5VX-2135F-00	COVER	1	1		
33	90269-08066	RIVET	2	2		
34	90464-15157	CLAMP	1	1		
35	90480-12237	GROMMET	2	2		
36	90387-06078	COLLAR	2	2		
37	90201-06055	WASHER, PLATE	2	2		
38	92017-06020	BOLT, BUTTON HEAD	2	2		



5VX1300-C210

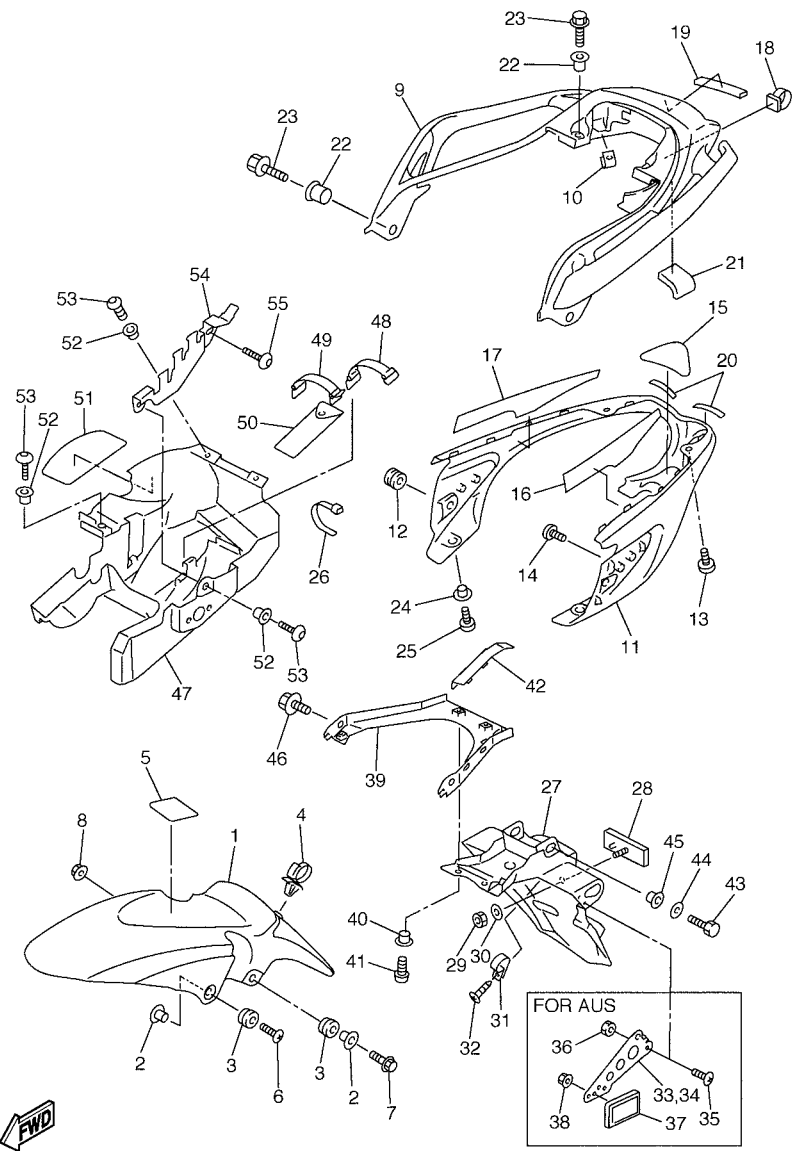
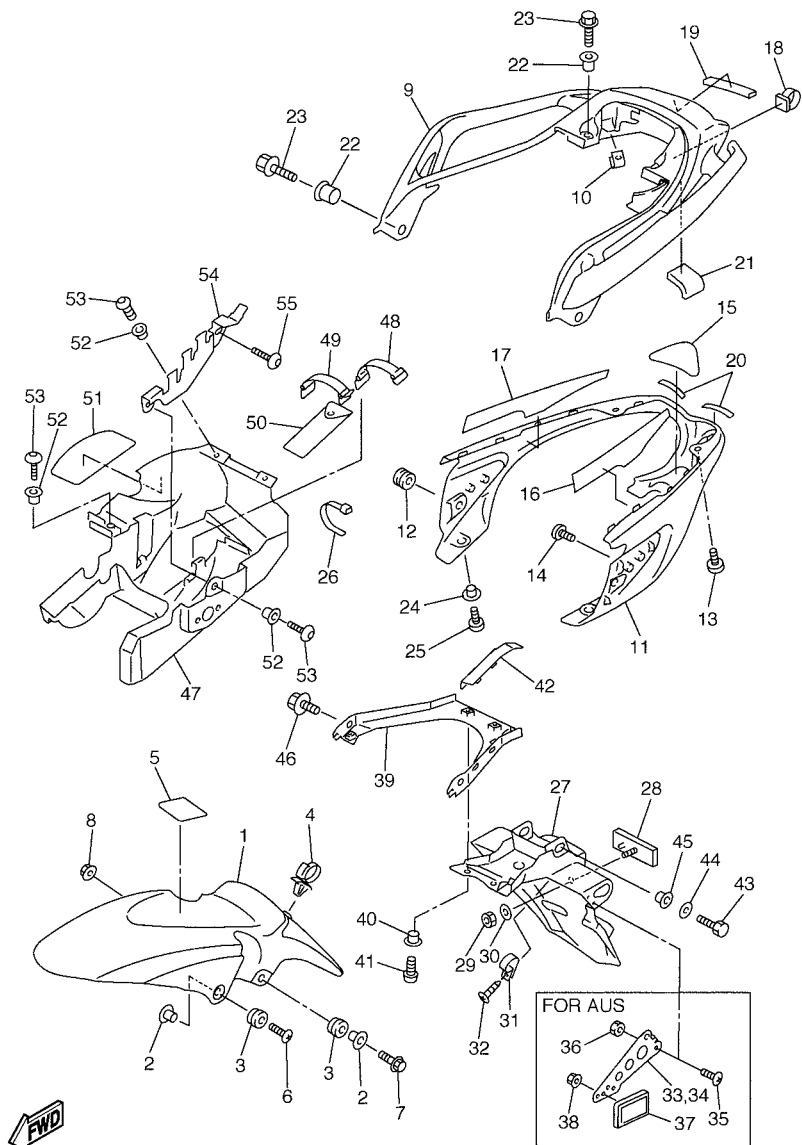

FIG. 21 FENDER

REF. NO.	PART NO.	DESCRIPTION	5VX1	5VX2	REMARKS
1	5VX-21511-10	FENDER, FRONT	1	1	FOR S3
	5VX-21511-00	FENDER, FRONT	1	1	FOR DPBML, DNBME
2	90387-065J6	COLLAR	4	4	
3	90480-12072	GROMMET	4	4	
4	90464-18002	CLAMP	1	1	
5	5VX-21575-00	SEAL 1	1	1	
6	90154-06061	SCREW, BINDING	2	2	
7	95024-06025	BOLT, FLANGE	2	2	
8	90179-06403	NUT	2	2	
9	5VX-24773-00-P0	HANDLE, SEAT	1	1	UR S3
	5VX-24773-00-P1	HANDLE, SEAT	1	1	UR DPBML
	5VX-24773-00-P2	HANDLE, SEAT	1	1	UR DNBME
10	90183-05061	NUT, SPRING	2	2	
11	5VX-21651-00	COVER, REAR FENDER	1	1	
12	90480-13398	GROMMET	2	2	
13	98907-05012	SCREW, BIND	2	2	
14	97707-50012	SCREW, TAPPING	2	2	
15	5VX-21669-00	SEAL	1	1	
16	5VX-21732-00	SEAL 1	1	1	
17	5VX-21735-00	SEAL 2	1	1	
18	90464-14002	CLAMP	1	1	
19	4XY-88158-00	DAMPER	1	1	
20	5VX-21639-00	DAMPER 2	2	2	
21	31A-28217-00	DAMPER 1	1	1	
22	90387-09003	COLLAR	4	4	
23	95827-08025	BOLT, FLANGE	4	4	
24	90387-064J1	COLLAR	2	2	



5VX1300-C210

FIG. 21 FENDER

REF. NO.	PART NO.	DESCRIPTION	5VX1	5VX2	REMARKS
25	98907-06012	SCREW, BIND	2	2	
26	90465-13152	CLAMP	2	2	
27	5VX-21621-00	FLAP	1		
	5VX-21621-10	FLAP		1	
28	3Y6-85130-02	REAR REFLECTOR ASSY	1	1	
29	95607-05100	NUT, U	1	1	
30	90201-05725	WASHER, PLATE	1	1	
31	90464-18029	CLAMP	1	1	
32	97707-40012	SCREW, TAPPING	1	1	
33	5VX-2164H-00	STAY 3		1	
34	5VX-2164J-00	STAY 4		1	
35	90150-04041	SCREW, ROUND HEAD	4		
36	95607-04100	NUT, U	4		
37	5SL-85110-00	REFLECTOR ASSY	2		
38	95707-05500	NUT, FLANGE	2		
39	5VX-2161G-00	BRACKET 6	1	1	
40	90387-064J1	COLLAR	2	2	
41	92017-06012	BOLT, BUTTON HEAD	2	2	
42	5VX-21665-00	GUIDE, MUD GUARD	1	1	
43	97007-06016	BOLT	2	2	
44	92907-06600	WASHER, PLATE	2	2	
45	90387-06075	COLLAR	2	2	
46	95827-08012	BOLT, FLANGE	2	2	
47	5VX-21629-00	GUARD, MUD	1	1	
48	3TJ-82131-00	BAND, BATTERY	1	1	
49	122-82131-00	BAND, BATTERY	1	1	
50	5VX-28100-00	TOOL KIT	1	1	



5VX1300-C210

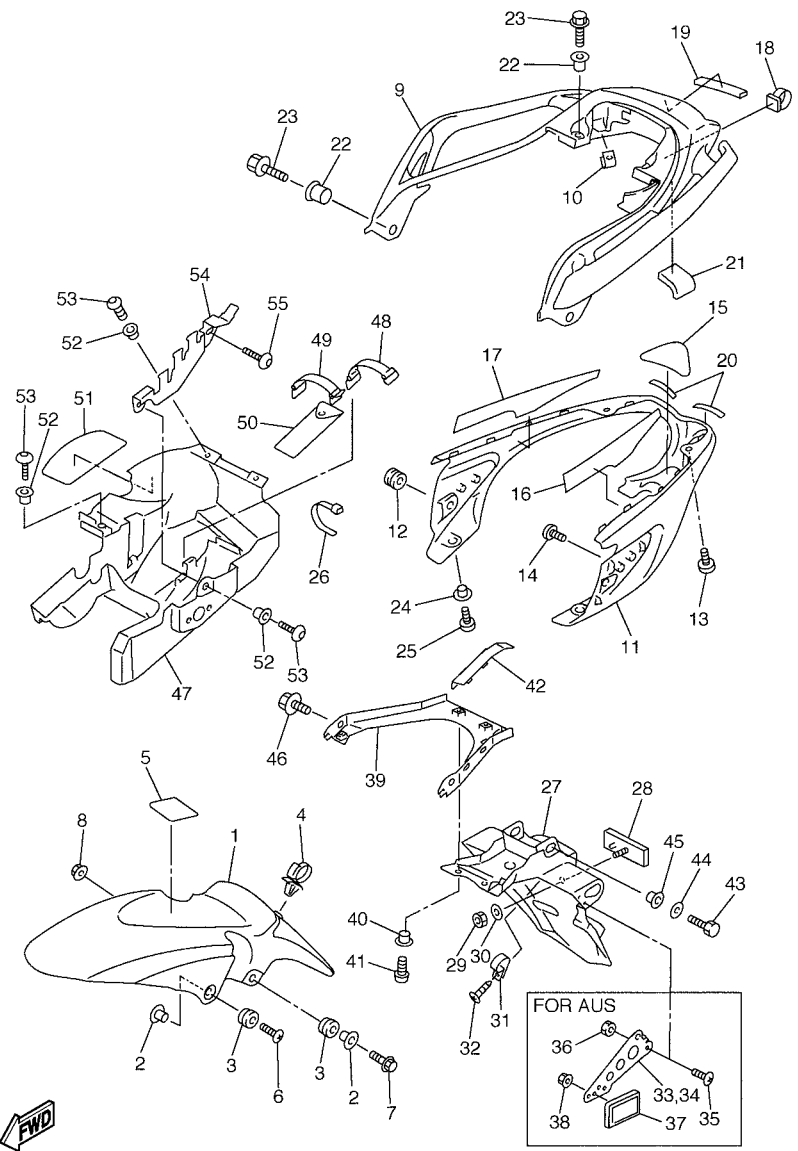
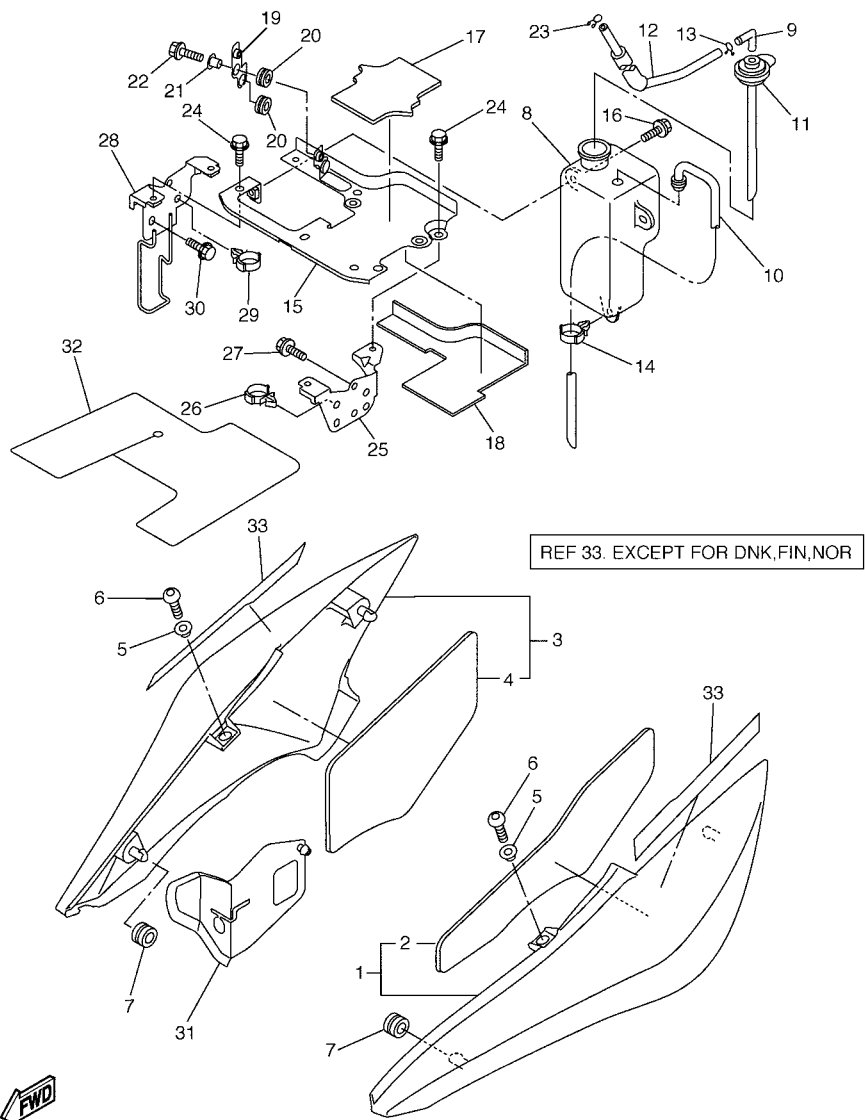

FIG. 21 FENDER

REF. NO.	PART NO.	DESCRIPTION	5VX1	5VX2				REMARKS
51	5VX-2173N-00	SEAL 4	1	1				
52	90387-064J1	COLLAR	4	4				
53	92017-06016	BOLT, BUTTON HEAD	4	4				
54	5VX-2164F-00	STAY 1	1	1				
55	92017-06016	BOLT, BUTTON HEAD	1	1				
<hr style="border-top: 1px dashed black;"/>								
<hr style="border-top: 1px dashed black;"/>								
<hr style="border-top: 1px dashed black;"/>								
<hr style="border-top: 1px dashed black;"/>								
<hr style="border-top: 1px dashed black;"/>								
<hr style="border-top: 1px dashed black;"/>								
<hr style="border-top: 1px dashed black;"/>								
<hr style="border-top: 1px dashed black;"/>								



5VX1300-C220

FIG. 22 SIDE COVER

REF. NO.	PART NO.	DESCRIPTION	5VX1	5VX2	REMARKS
1	5VX-21710-10	SIDE COVER ASSY 1	1	1	FOR S3
	5VX-21710-00	SIDE COVER ASSY 1	1	1	FOR DPBML, DNBME
2	5VX-2174X-00	.DAMPER	1	1	
3	5VX-21720-10	SIDE COVER ASSY 2	1	1	FOR S3
	5VX-21720-00	SIDE COVER ASSY 2	1	1	FOR DPBML, DNBME
4	5VX-2174Y-00	.DAMPER	1	1	
5	90387-064J1	COLLAR	2	2	
6	92017-06014	BOLT, BUTTON HEAD	2	2	
7	90480-01558	GROMMET	2	2	
8	5VX-21871-00	TANK, RECOVERY	1	1	
9	26H-21828-00	ELBOW	1	1	
10	5VX-21816-00	PIPE 1	1	1	
11	5VX-21875-00	CAP	1	1	
12	90445-08018	HOSE	1	1	
13	90467-08075	CLIP	1	1	
14	90464-20181	CLAMP	1	1	
15	5VX-21873-00	BRACKET, RECOVERY TANK	1	1	
16	90119-06117	BOLT, WITH WASHER	2	2	
17	5VX-21779-00	DAMPER, LOCATING 2	1	1	
18	5VX-2173M-00	SEAL 3	1	1	
19	5VX-21228-00	BRACKET, RESERVE TANK	1	1	
20	90480-13163	GROMMET	2	2	
21	90560-06201	SPACER	1	1	
22	95807-06016	BOLT, FLANGE	1	1	
23	90467-08075	CLIP	1	1	
24	95827-06010	BOLT, FLANGE	4	4	
25	5VX-21843-00	STAY, 4	1	1	

D7

FIG. 22 SIDE COVER

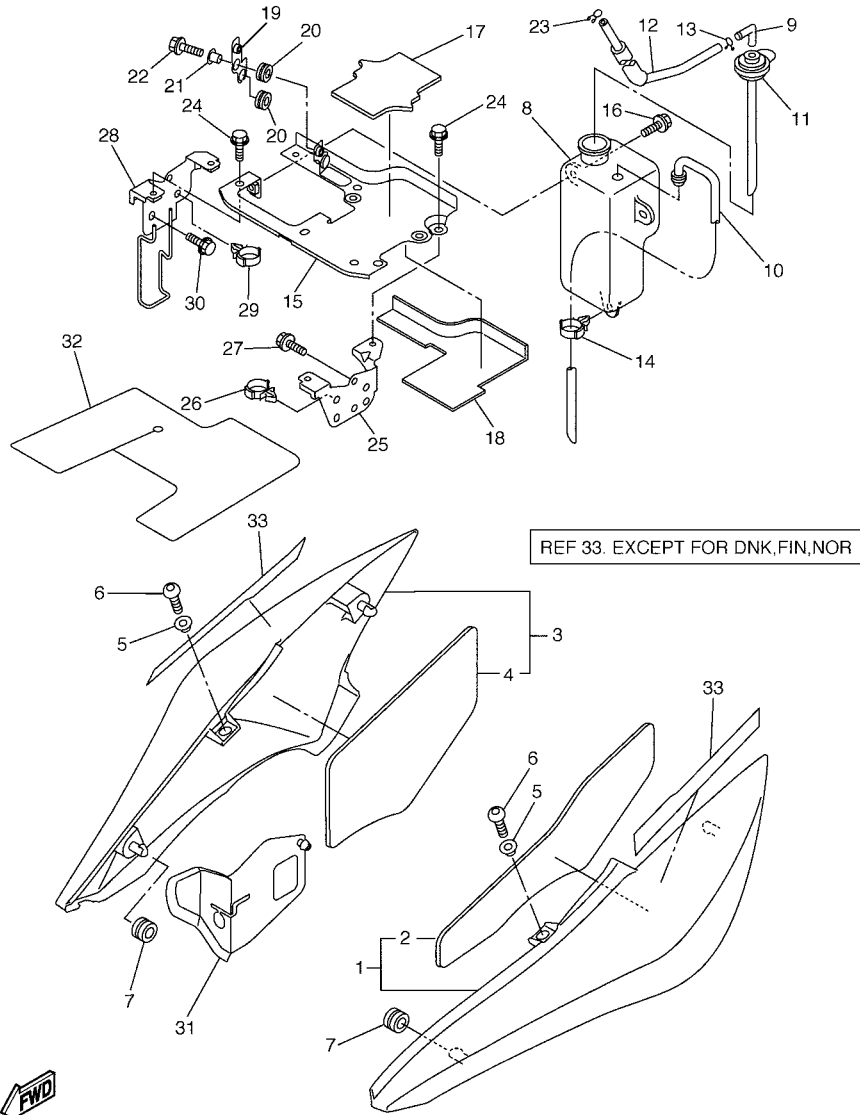

REF 33. EXCEPT FOR DNK,FIN,NOR



5VX1300-C220

REF. NO.	PART NO.	DESCRIPTION	5VX1	5VX2			REMARKS
26	90464-20181	CLAMP	1	1			
27	95827-06010	BOLT, FLANGE	2	2			
28	5VX-22836-00	STAY, 3	1	1			
29	90464-16006	CLAMP	1	1			
30	95827-06010	BOLT, FLANGE	2	2			
31	5VX-2163A-00	COVER, REAR FENDER 1	1	1			
32	5VX-2177F-00	FLAP	1	1			
33	5VX-21781-20	EMBLEM 1	2	2			FOR S3
	5VX-21781-00	EMBLEM 1	2	2			FOR DPBML, DNBME

FIG. 23 REAR ARM

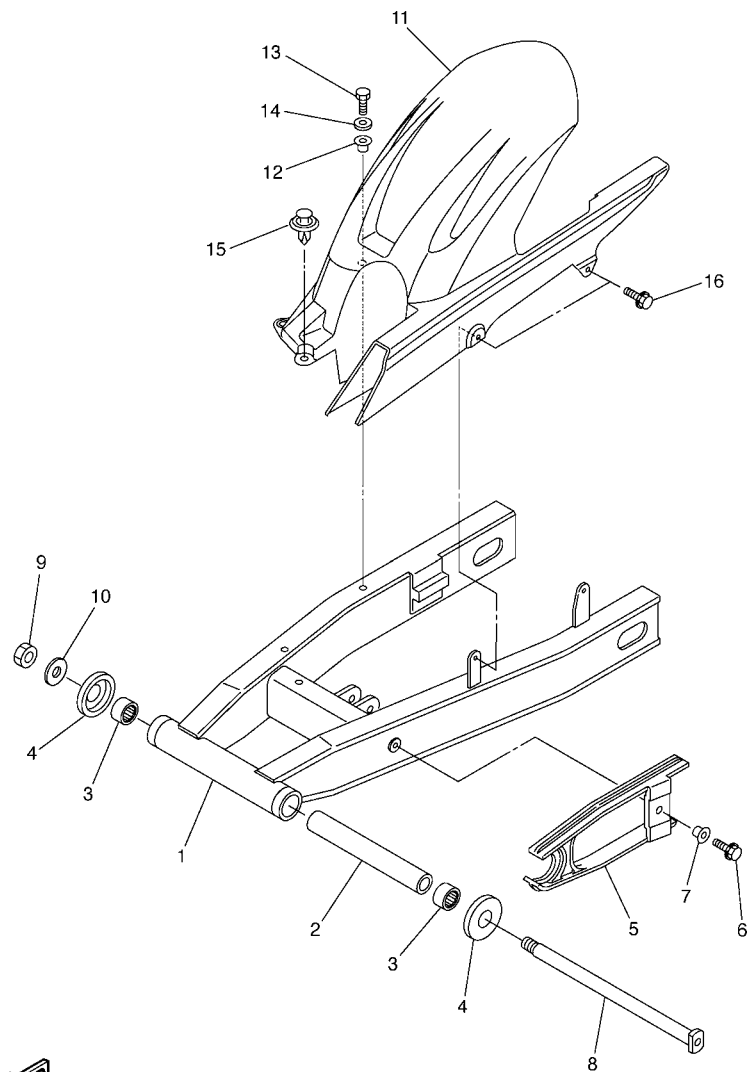

5VX1351-C230

REF. NO.	PART NO.	DESCRIPTION	5VX1	5VX2		REMARKS
1	5VX-22110-00	REAR ARM COMP.	1	1		
2	5EB-22184-00	BUSH	1	1		
3	93315-42523	BEARING	2	2		
4	5JJ-22128-00	COVER, THRUST 1	2	2		
5	5VX-22151-00	SEAL, GUARD	1	1		
6	90119-06096	BOLT, WITH WASHER	1	1		
7	90387-06372	COLLAR	1	1		
8	4FN-22141-00	SHAFT, PIVOT	1	1		
9	90185-18104	NUT, SELF-LOCKING	1	1		
10	90201-186M4	WASHER, PLATE	1	1		
11	5VX-21650-00	REAR FENDER COMP.	1	1		
12	90387-064J1	COLLAR	2	2		
13	97007-06025	BOLT	2	2		
14	92907-06600	WASHER, PLATE	2	2		
15	90269-08001	RIVET	1	1		
16	90119-06117	BOLT, WITH WASHER	2	2		

FIG. 24 REAR SUSPENSION

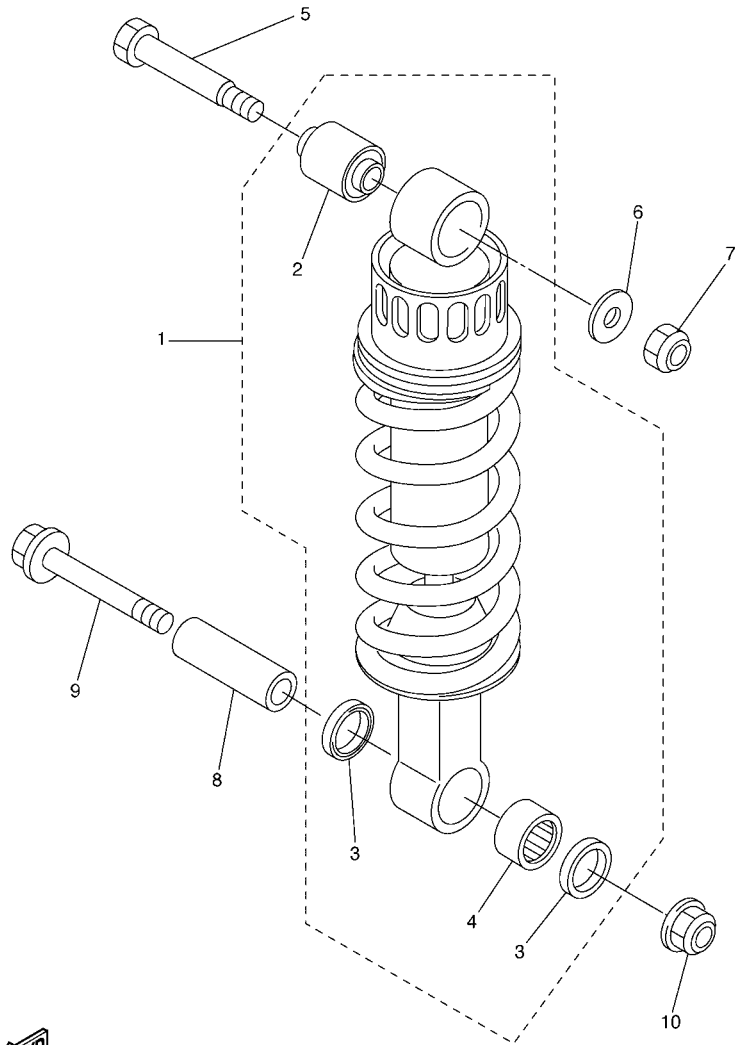

REF. NO.	PART NO.	DESCRIPTION	5VX1	5VX2			REMARKS
1	5VX-22210-00	SHOCK ABSORBER ASSY, REAR	1	1			
2	34L-22216-00	.BUSH, REAR SHOCK ABSORBER	1	1			
3	93109-17071	.OIL SEAL	2	2			
4	93315-31758	.BEARING	1	1			
5	90109-10654	BOLT	1	1			
6	90201-101J1	WASHER, PLATE	1	1			
7	95607-10100	NUT, U	1	1			
8	90387-1012B	COLLAR	1	1			
9	90105-10323	BOLT, FLANGE	1	1			
10	95607-10200	NUT, SELF-LOCKING	1	1			

FWD
5VX1351-C240

D10

FIG. 25 STEERING

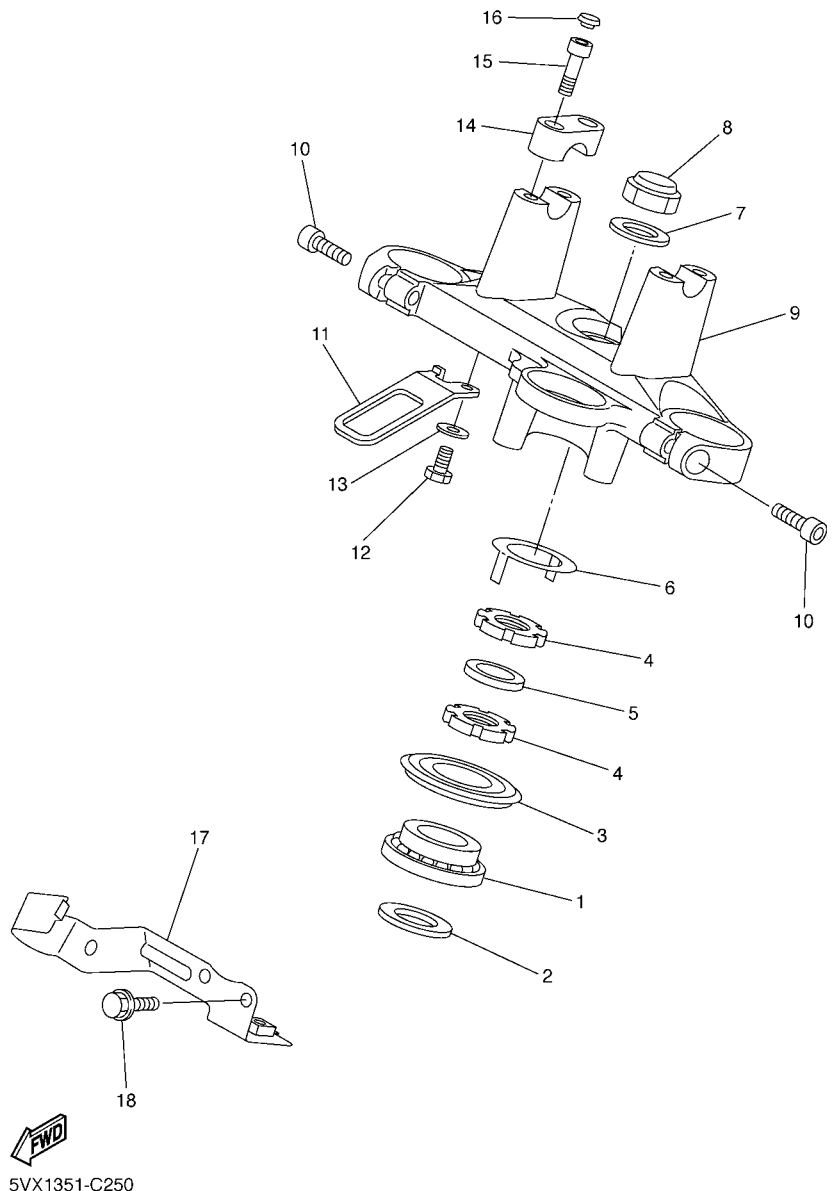

REF. NO.	PART NO.	DESCRIPTION	5VX1	5VX2	REMARKS
1	93399-99931	BEARING	1	1	
2	90202-24190	WASHER, PLATE	1	1	
3	5VX-23415-00	COVER, BALL RACE 1	1	1	
4	90179-25033	NUT	2	2	
5	90202-26142	WASHER, PLATE	1	1	
6	26H-23418-01	WASHER, SPECIAL	1	1	
7	90201-220T0	WASHER, PLATE	1	1	
8	90176-22081	NUT, CROWN	1	1	
9	5VX-23435-00	CROWN, HANDLE	1	1	
10	91314-08030	BOLT	2	2	
11	5VX-23389-00	GUIDE, CABLE	1	1	
12	97017-06016	BOLT	1	1	
13	92907-06600	WASHER, PLATE	1	1	
14	4H7-23441-00-35	HOLDER, HANDLE UPPER	2	2	SL
15	91317-08030	BOLT	4	4	
16	90338-06004	PLUG	4	4	
17	5VX-23377-00	BRACKET, HORN	1	1	
18	95807-06012	BOLT, FLANGE	2	2	

D11

FIG. 26 FRONT FORK

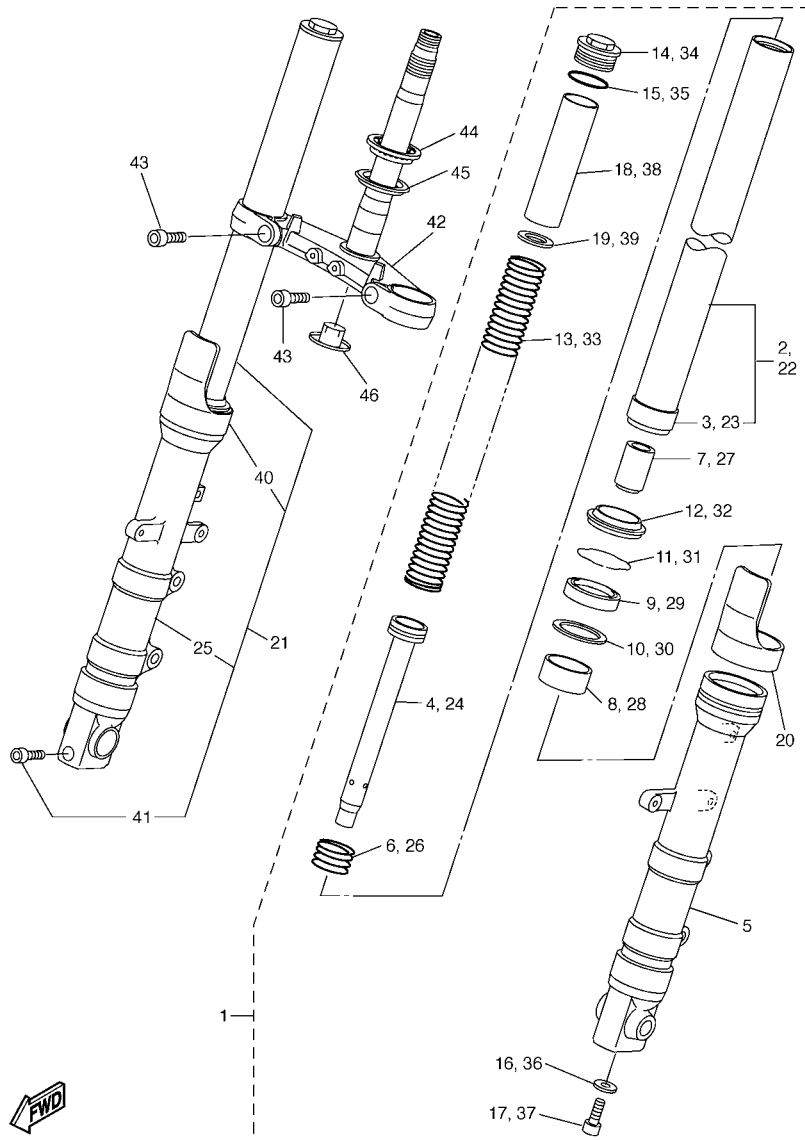

5VX1351-C260

REF. NO.	PART NO.	DESCRIPTION	5VX1	5VX2	REMARKS
1	5VX-23102-00	FRONT FORK ASSY (L.H)	1	1	
2	5VX-23110-00	.INNER TUBE COMP.1	1	1	
3	4TX-23135-A0	..METAL, SLIDE 2	1	1	
4	5VX-23170-00	.CYLINDER COMP., FRONT FORK	1	1	
5	5VX-23126-00	.TUBE, OUTER (LEFT)	1	1	
6	4TX-23151-00	.SPRING, REBOUND	1	1	
7	4TX-23173-00	.SPINDLE, TAPER	1	1	
8	4TX-23125-A0	.METAL, SLIDE 1	1	1	
9	5VX-23145-00	.OIL SEAL	1	1	
10	4TX-23115-00	.GUIDE, COVER UPPER	1	1	
11	4TX-23156-00	.CLIP, OIL SEAL	1	1	
12	4TX-23144-00	.SEAL, DUST	1	1	
13	5VX-23141-00	.SPRING, FRONT FORK	1	1	
14	5VX-2311H-00	.FORK, BOLT	1	1	
15	93210-34504	.O-RING	1	1	
16	90430-10171	.GASKET	1	1	
17	90110-10N52	.BOLT, HEXAGON SOCKET HEAD	1	1	
18	5VX-23118-00	.SPACER	1	1	
19	90201-231E1	.WASHER, PLATE	1	1	
20	4TX-2331G-00	.COVER	1	1	
21	5VX-23103-00	FRONT FORK ASSY (R.H)	1	1	
22	5VX-23110-00	.INNER TUBE COMP.1	1	1	
23	4TX-23135-A0	..METAL, SLIDE 2	1	1	
24	5VX-23170-00	.CYLINDER COMP., FRONT FORK	1	1	
25	5VX-23136-00	.TUBE, OUTER (RIGHT)	1	1	
26	4TX-23151-00	.SPRING, REBOUND	1	1	
27	4TX-23173-00	.SPINDLE, TAPER	1	1	

FIG. 26 FRONT FORK

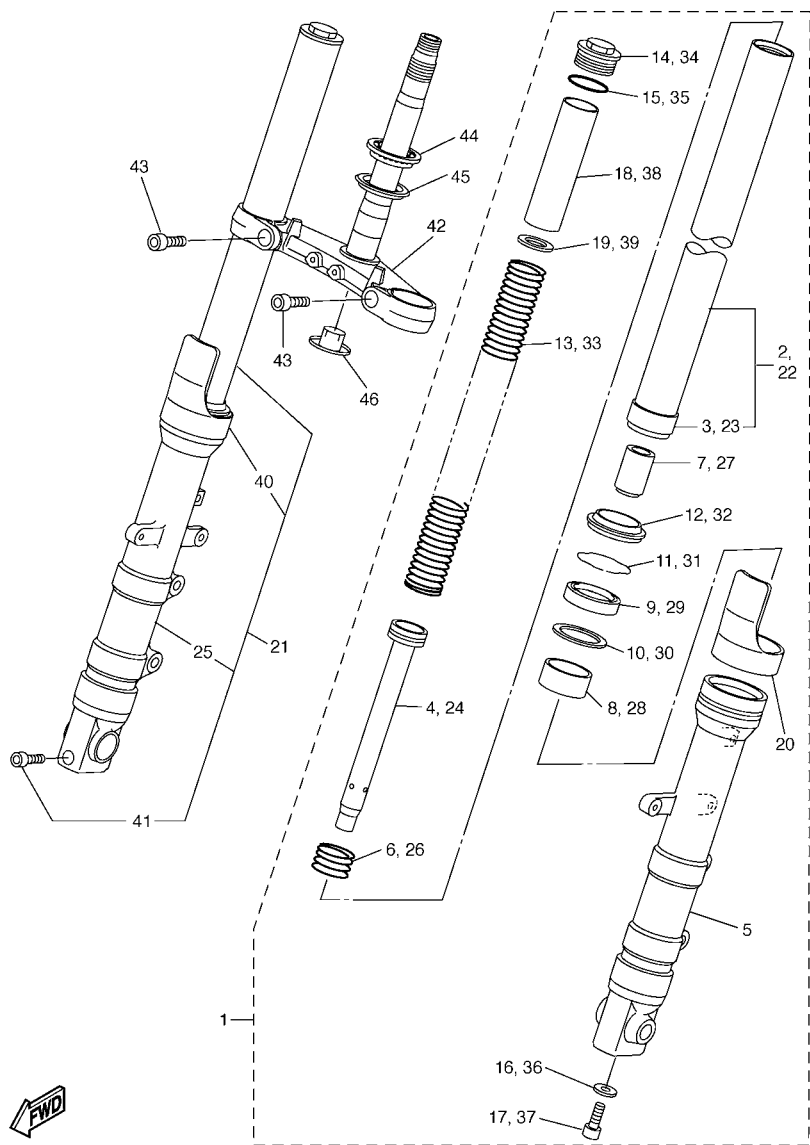

5VX1351-C260

REF. NO.	PART NO.	DESCRIPTION	5VX1	5VX2	REMARKS
28	4TX-23125-A0	.METAL, SLIDE 1	1	1	
29	5VX-23145-00	.OIL SEAL	1	1	
30	4TX-23115-00	.GUIDE, COVER UPPER	1	1	
31	4TX-23156-00	.CLIP, OIL SEAL	1	1	
32	4TX-23144-00	.SEAL, DUST	1	1	
33	5VX-23141-00	.SPRING, FRONT FORK	1	1	
34	5VX-2311H-00	.FORK, BOLT	1	1	
35	93210-34504	.O-RING	1	1	
36	90430-10171	.GASKET	1	1	
37	90110-10N52	.BOLT, HEXAGON SOCKET HEAD	1	1	
38	5VX-23118-00	.SPACER	1	1	
39	90201-231E1	.WASHER, PLATE	1	1	
40	4TX-2331G-00	.COVER	1	1	
41	91314-08045	.BOLT	1	1	
42	5VX-23340-00	UNDER BRACKET COMP.	1	1	
43	91317-10025	BOLT	2	2	
44	93399-99932	BEARING	1	1	
45	3FV-23462-00	SEAL, STEERING	1	1	
46	4KM-23123-01	COVER, LOWER 1	1	1	

FIG. 27 FUEL TANK

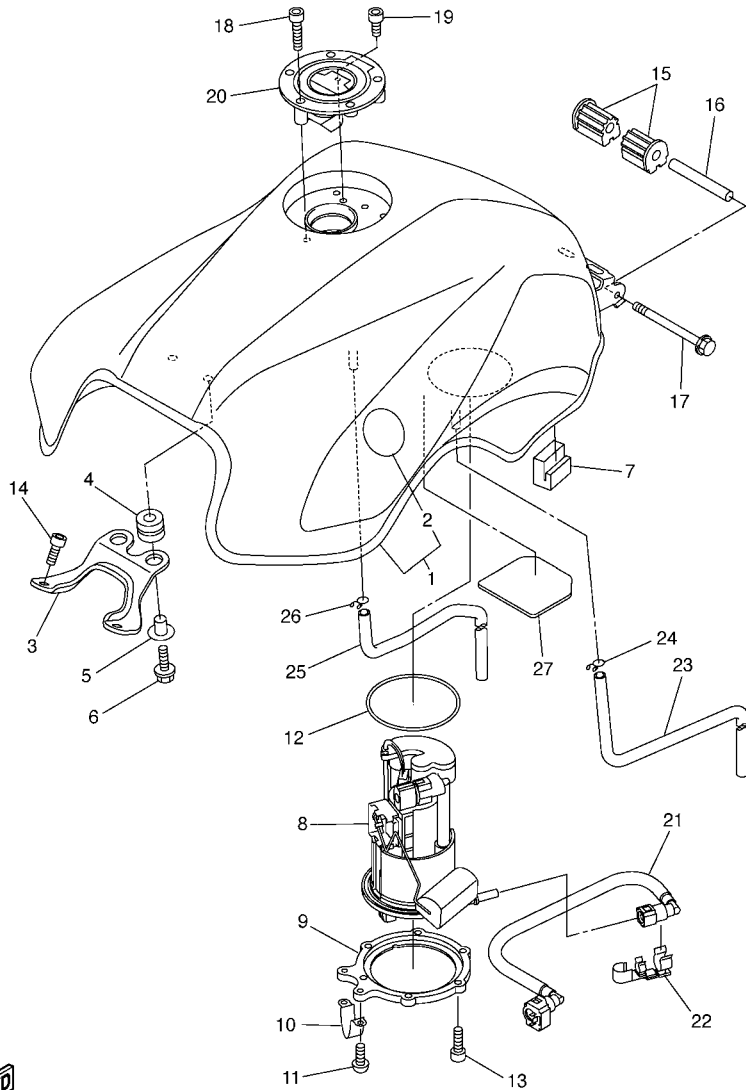

REF. NO.	PART NO.	DESCRIPTION	5VX1	5VX2	REMARKS
1	5VX-Y2410-30-01	FUEL TANK COMP.	1	1	UR S3
	5VX-Y2410-30-02	FUEL TANK COMP.	1	1	UR DPBML
	5VX-Y2410-30-03	FUEL TANK COMP.	1	1	UR DNBME
2	5VX-2411B-00	.TUNING FORK MARK	2	2	
3	5VX-24191-00	BRACKET, FUEL TANK 1	1	1	
4	90480-15005	GROMMET	2	2	
5	90387-06068	COLLAR	2	2	
6	90119-06062	BOLT, WITH WASHER	2	2	
7	5VX-24183-00	DAMPER, LOCATING 3	2	2	
8	5VX-13907-00	FUEL PUMP COMP.	1	1	
9	5SL-24491-00	BRACKET, FUEL PUMP	1	1	
10	5PW-24192-00	BRACKET, FUEL TANK 2	1	1	
11	98907-05008	SCREW, BIND	2	2	
12	5JW-24486-00	O-RING	1	1	
13	90110-05014	BOLT, HEXAGON SOCKET HEAD	6	6	
14	90110-06079	BOLT, HEXAGON SOCKET HEAD	2	2	
15	5VX-24181-00	DAMPER, LOCATING 1	2	2	
16	90387-061W6	COLLAR	1	1	
17	95827-06090	BOLT, FLANGE	1	1	
18	90110-05112	BOLT, HEXAGON SOCKET HEAD	3	3	
19	91317-05010	BOLT	1	1	
20	5JJ-24602-00	CAP ASSY	1	1	
21	5VX-13971-00	PIPE, FUEL 1	1	1	
22	90464-16005	CLAMP	1	1	
23	90445-10033	HOSE	1	1	
24	90467-10008	CLIP	1	1	
25	90445-10032	HOSE	1	1	



5VX1351-C270

FIG. 27 FUEL TANK

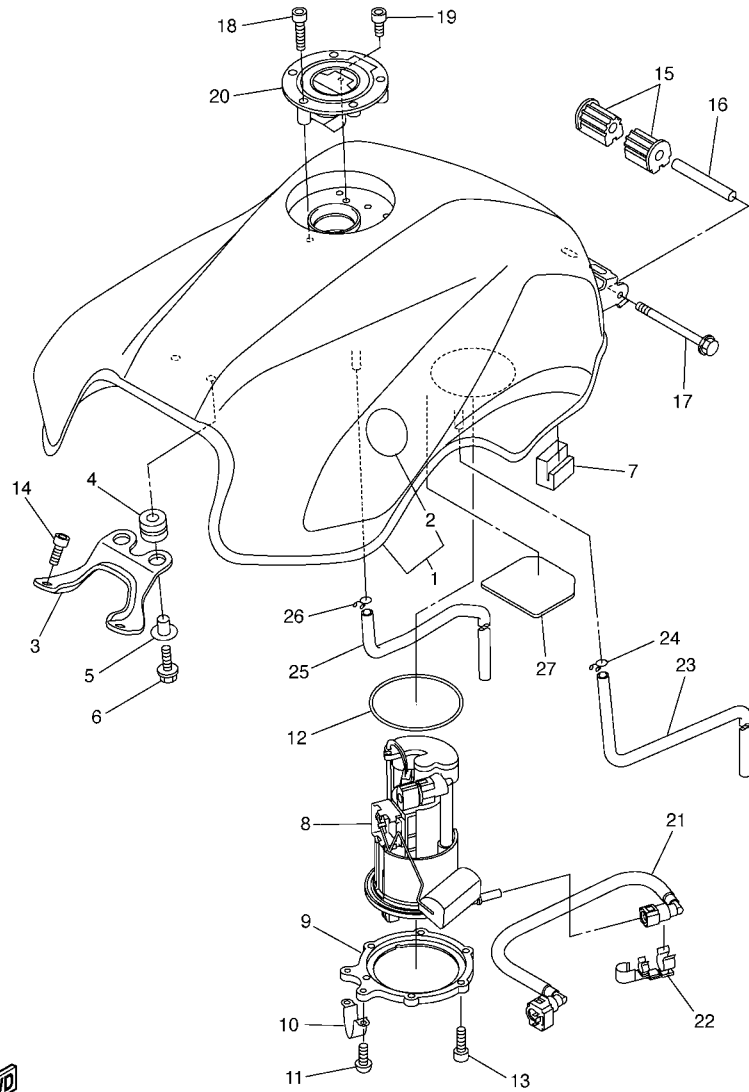

REF. NO.	PART NO.	DESCRIPTION	5VX1	5VX2				REMARKS
26	90467-10008	CLIP	1	1				
27	5VX-24141-00	PROTECTOR, FUEL TANK	1	1				



5VX1351-C270

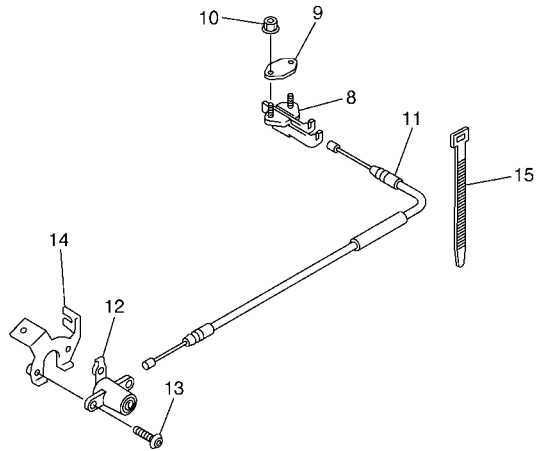
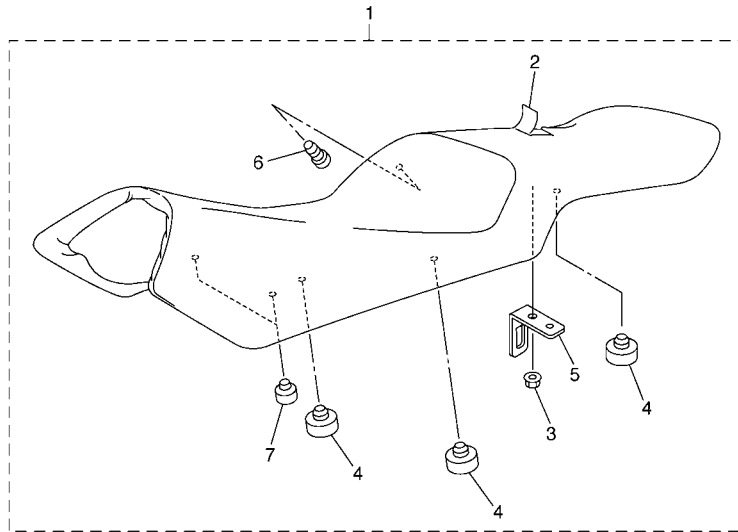

5VX1351-C280

FIG. 28 SEAT

REF. NO.	PART NO.	DESCRIPTION	5VX1	5VX2				REMARKS
1	5VX-24730-00	DOUBLE SEAT ASSY	1	1				
2	5VX-24711-00	.COVER, SINGLE SEAT	1	1				
3	95707-06500	.NUT, FLANGE	1	1				
4	371-27114-00	.STOPPER, MAIN STAND	6	6				
5	4NK-24728-00	.BRACKET, SEAT	1	1				
6	90338-06018	.PLUG	1	1				
7	5VX-24724-00	.DAMPER, SEAT	2	2				
8	4BP-24780-00	SEAT LOCK ASSY	1	1				
9	4BP-24792-00	PLATE	1	1				
10	95707-06500	NUT, FLANGE	2	2				
11	5VX-2478E-00	CABLE, SEAT LOCK	1	1				
12	2TV-W2470-00	SEAT LOCK ASSY	1	1				
13	90149-06308	SCREW	2	2				
14	5PW-2117K-00	STAY, LOCK	1	1				
15	90464-16061	CLAMP	1	1				

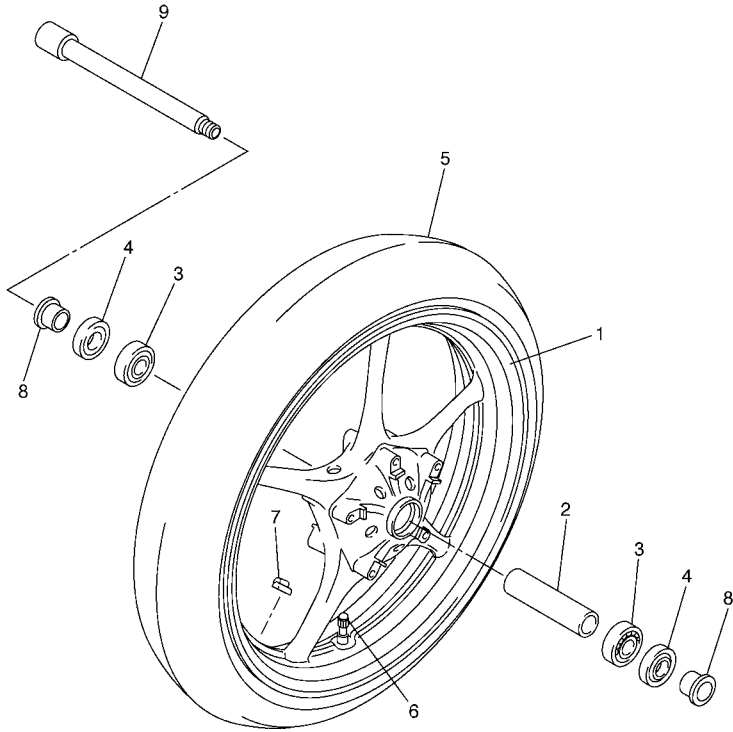

FIG. 29 FRONT WHEEL

REF. NO.	PART NO.	DESCRIPTION	5VX1	5VX2	REMARKS
1	5SL-25168-00-35	CAST WHEEL, FRONT	1	1	SL
2	4XV-25117-00	SPACER, BEARING	1	1	
3	93306-00420	BEARING (B6004)	2	2	
4	93106-28043	OIL SEAL	2	2	
5	94112-17066	TIRE(120/70ZR17M/C 58W BT020F)	1	1	UR BRIDGESTONE
	94112-17067	TIRE(120/70ZR17M/C 58W D252F)	1	1	UR DUNLOP
6	93900-00030	VALVE, RIM (TR412)	1	1	TAIHEIYO
7	5MT-25398-00	BALANCER, WHEEL (10G)	1	1	UR
	5MT-25398-10	BALANCER, WHEEL (20G)	1	1	UR
	5MT-25398-20	BALANCER, WHEEL (30G)	1	1	UR
8	90387-22002	COLLAR	2	2	
9	4XV-25181-00	AXLE, WHEEL	1	1	



5VX1351-C290

FIG. 30 FRONT BRAKE CALIPER

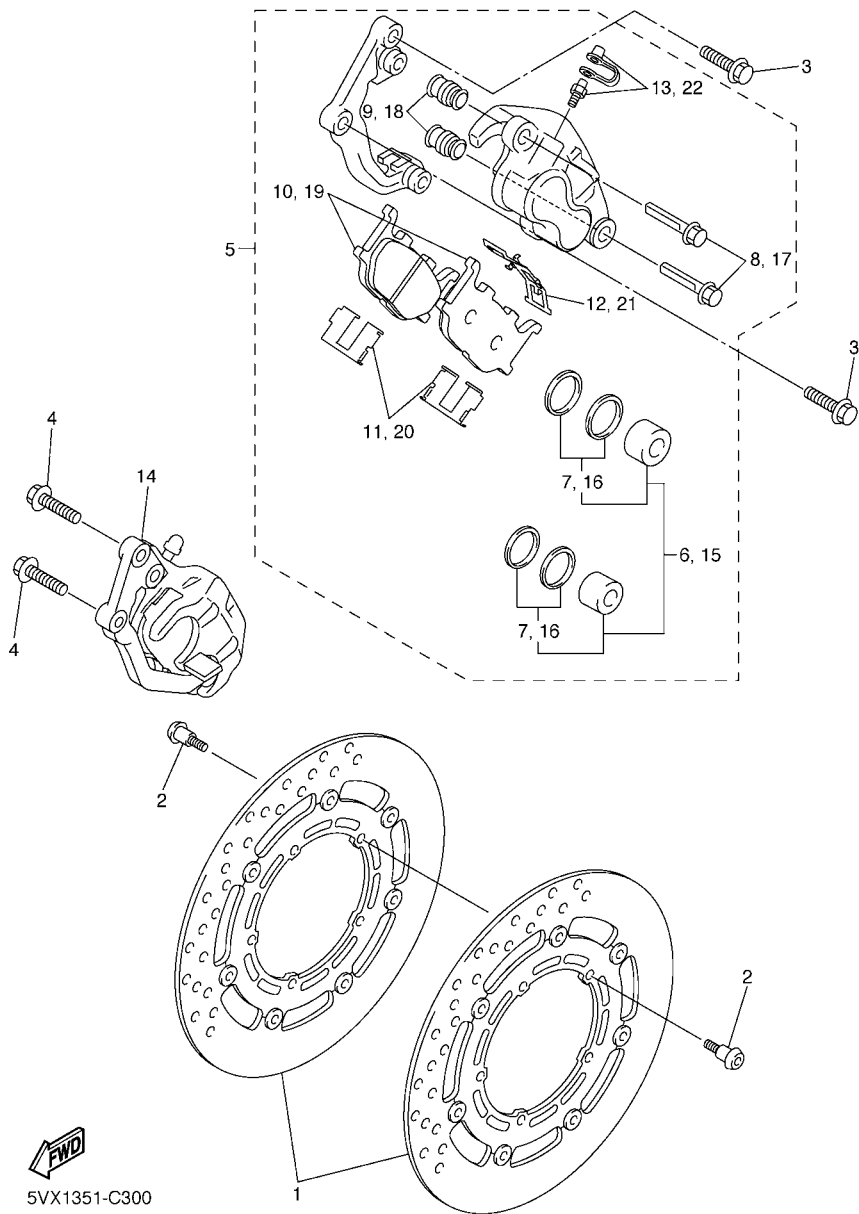

5VX1351-C300

REF. NO.	PART NO.	DESCRIPTION	5VX1	5VX2			REMARKS
1	5VX-2581T-00	DISC BRAKE ASSY	2	2			
2	90109-064G6	BOLT	10	10			
3	90105-10638	BOLT, FLANGE	2	2			
4	90105-10638	BOLT, FLANGE	2	2			
5	5VX-2580T-00	CALIPER ASSY (LEFT)	1	1			
6	5KS-W0057-00	.PISTON ASSY, CALIPER	1	1			
7	4FU-W0047-00	..CALIPER SEAL KIT	1	1			
8	5JW-25914-10	.PIN, SLIDE	2	2			
9	4TT-25937-00	.BOOT 2	2	2			
10	5VX-W0045-00	.BRAKE PAD KIT	1	1			
11	4BP-25919-00	.SUPPORT, PAD	2	2			
12	3YX-25929-00	.SPRING, ANTI RATTLE	1	1			
13	51L-W0048-00	.BLEED SCREW KIT	1	1			
14	5VX-2580U-00	CALIPER ASSY (RIGHT)	1	1			
15	5KS-W0057-00	.PISTON ASSY, CALIPER	1	1			
16	4FU-W0047-00	..CALIPER SEAL KIT	1	1			
17	5JW-25914-10	.PIN, SLIDE	2	2			
18	4TT-25937-00	.BOOT 2	2	2			
19	5VX-W0045-00	.BRAKE PAD KIT	1	1			
20	4BP-25919-00	.SUPPORT, PAD	2	2			
21	3YX-25929-00	.SPRING, ANTI RATTLE	1	1			
22	51L-W0048-00	.BLEED SCREW KIT	1	1			

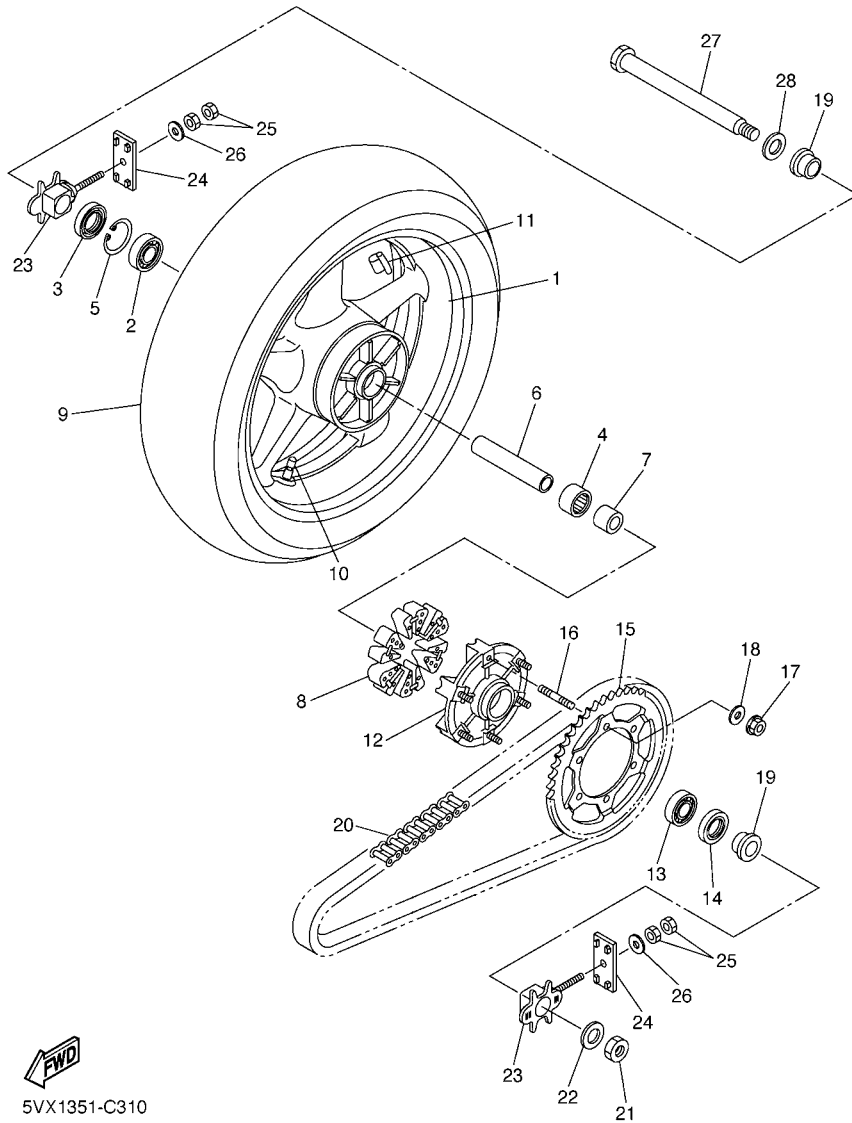

5VX1351-C310

FIG. 31 REAR WHEEL

REF. NO.	PART NO.	DESCRIPTION	5VX1	5VX2	REMARKS
1	5SL-25338-00-35	CAST WHEEL, REAR	1	1	SL
2	93306-20531	BEARING	1	1	
3	93106-40013	OIL SEAL	1	1	
4	93317-43580	BEARING	1	1	
5	93420-61M07	CIRCLIP	1	1	
6	4XV-25317-00	SPACER, BEARING	1	1	
7	5SL-25383-00	COLLAR, WHEEL	1	1	
8	5VX-25364-00	DAMPER	6	6	
9	94118-17041	TIRE(180/55ZR17M/C 73W BT020R)	1	1	UR BRIDGESTONE
	94118-17053	TIRE(180/55ZR17M/C 73W D252)	1	1	UR DUNLOP
10	93900-00030	VALVE, RIM (TR412)	1	1	TAIHEIYO
11	5MT-25398-00	BALANCER, WHEEL (10G)	1	1	UR
	5MT-25398-10	BALANCER, WHEEL (20G)	1	1	UR
	5MT-25398-20	BALANCER, WHEEL (30G)	1	1	UR
12	5SL-25366-00	CLUTCH, HUB	1	1	
13	93306-20531	BEARING	1	1	
14	93106-40013	OIL SEAL	1	1	
15	5VX-25446-00	SPROCKET, DRIVEN (46T)	1	1	
16	90116-10485	BOLT, STUD	6	6	
17	90185-10009	NUT, SELF-LOCKING	6	6	
18	90201-10021	WASHER, PLATE	6	6	
19	90387-28001	COLLAR	2	2	
20	94582-11118	CHAIN (DID50V4-118LE)	1	1	
21	90185-24165	NUT, SELF-LOCKING	1	1	
22	90201-25015	WASHER, PLATE	1	1	
23	5VX-25388-01	PULLER, CHAIN 1	2	2	
24	2GH-25389-00	PULLER, CHAIN 2	2	2	

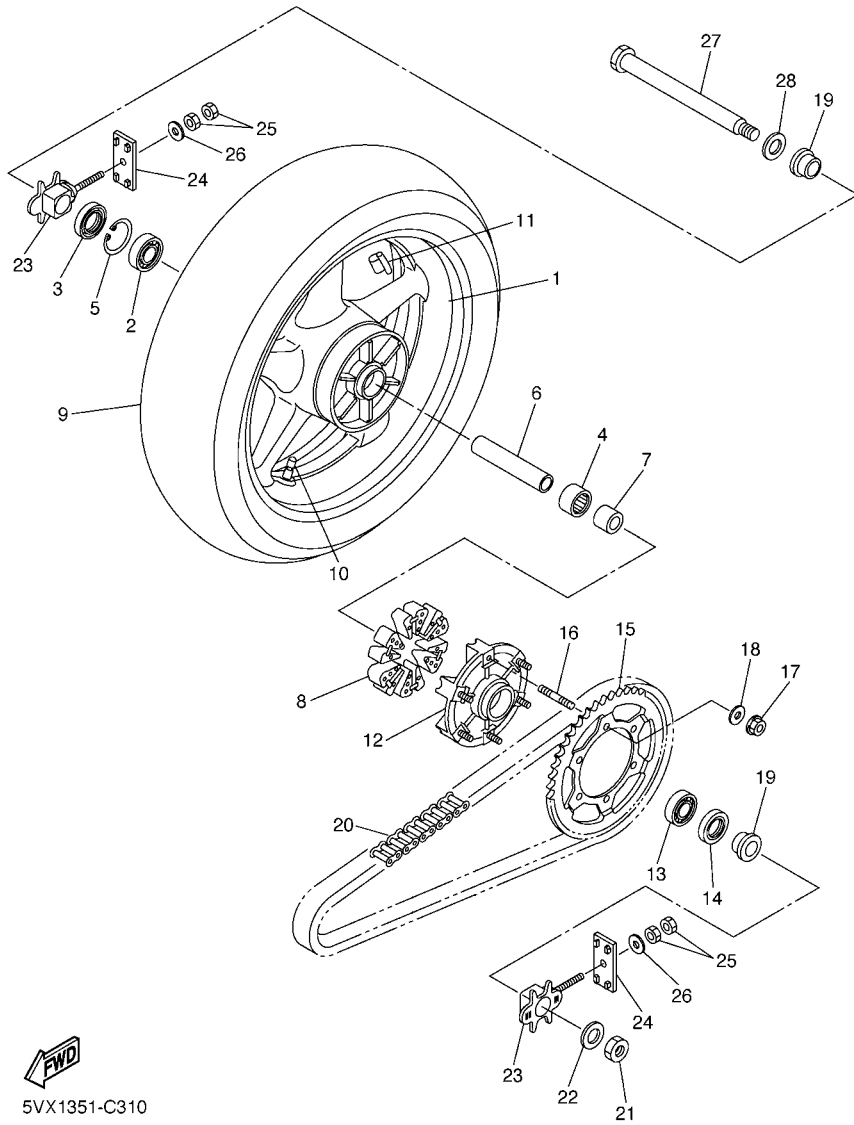

5VX1351-C310

FIG. 31 REAR WHEEL

REF. NO.	PART NO.	DESCRIPTION	5VX1	5VX2				REMARKS
25	95307-08600	NUT	4	4				
26	92907-08200	WASHER	2	2				
27	5VX-25381-00	AXLE, WHEEL	1	1				
28	90201-28014	WASHER, PLATE	1	1				

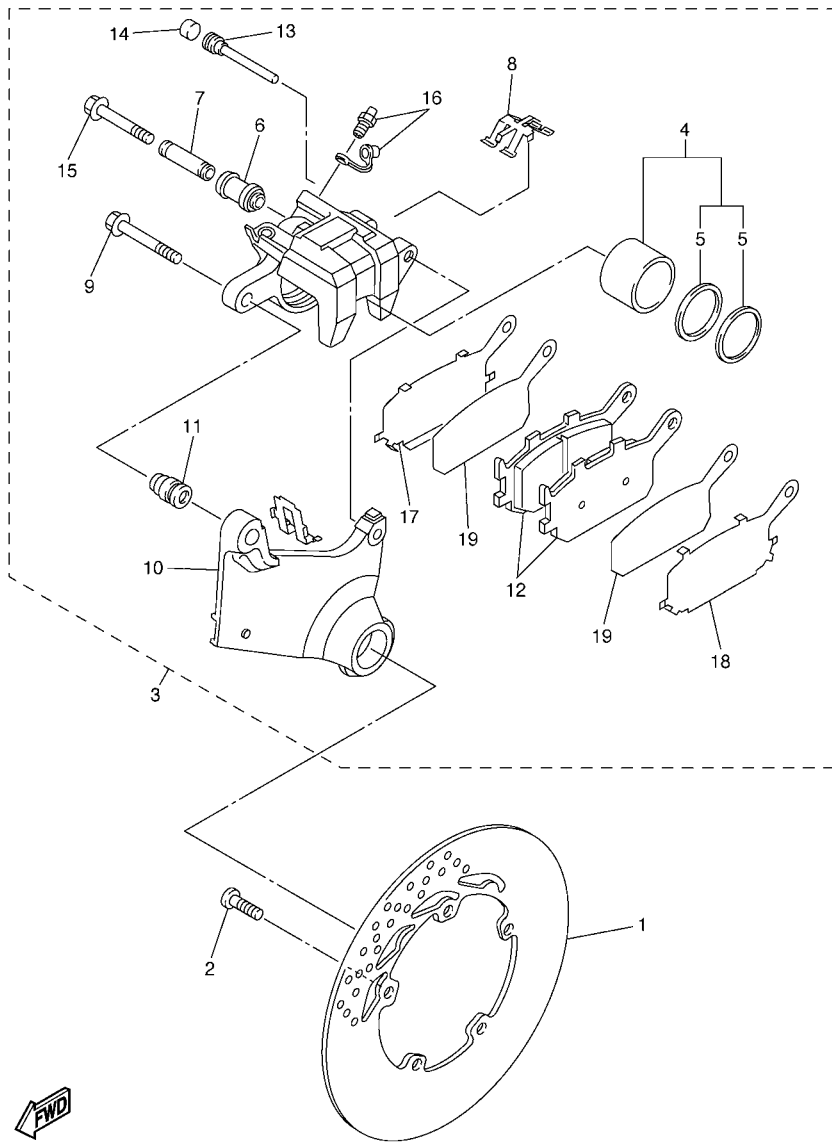

5VX1351-C320

FIG. 32 REAR BRAKE CALIPER

REF. NO.	PART NO.	DESCRIPTION	5VX1	5VX2	REMARKS
1	5VX-2582W-00	DISC, REAR BRAKE 2	1	1	
2	90109-08045	BOLT	5	5	
3	5VX-2580W-00	CALIPER ASSY, REAR 2	1	1	
4	5SL-W0057-00	.PISTON ASSY, CALIPER	1	1	
5	5SL-W0047-00	..CALIPER SEAL KIT	1	1	
6	5SL-25917-00	.BOOT, CALIPER	1	1	
7	5SL-25838-00	.SLEEVE, CALIPER	1	1	
8	5SL-25919-00	.SUPPORT, PAD	1	1	
9	5SL-25914-00	.PIN, SLIDE	1	1	
10	5VX-25921-50	.BRACKET, SUPPORT	1	1	
11	3JD-25917-00	.BOOT, CALIPER	1	1	
12	5VX-W0046-00	.BRAKE PAD KIT 2	1	1	
13	8CR-25924-00	.PIN, PAD	1	1	
14	5DH-25916-00	.PLUG	1	1	
15	5SL-25926-00	.BOLT	1	1	
16	1UY-W0048-00	.BLEED SCREW KIT	1	1	
17	5SL-25827-00	.SHIM, CALIPER	1	1	
18	5SL-25827-10	.SHIM, CALIPER	1	1	
19	5SL-25828-00	.SHIM, CALIPER	2	2	

FIG. 33 STEERING HANDLE & CABLE

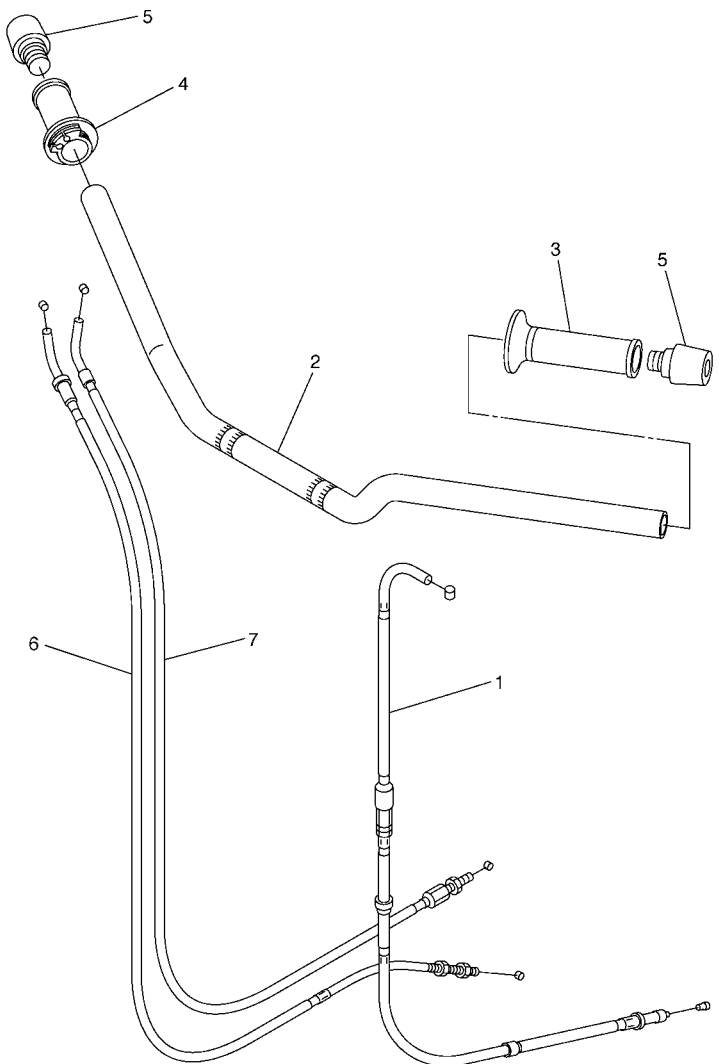

REF. NO.	PART NO.	DESCRIPTION	5VX1	5VX2				REMARKS
1	5VX-26335-00	CABLE, CLUTCH	1	1				
2	5VX-26111-00	HANDLEBAR	1	1				
3	4YR-26241-01	GRIP (LEFT)	1	1				
4	4YR-26240-01	GRIP ASSY	1	1				
5	51J-26246-01	END, GRIP	2	2				
6	5VX-26311-00	CABLE, THROTTLE 1	1	1				
7	5VX-26312-00	CABLE, THROTTLE 2	1	1				

FWD
5VX1351-C330

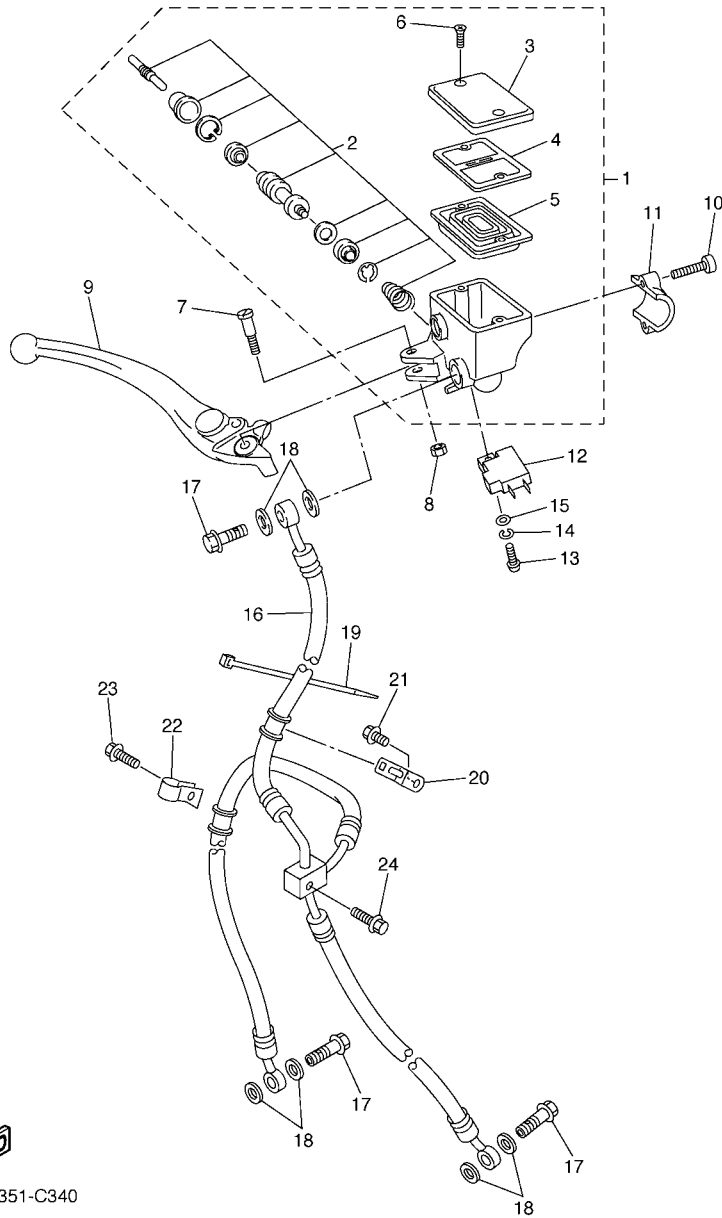

FWD
5VX1351-C340

FIG. 34 FRONT MASTER CYLINDER

REF. NO.	PART NO.	DESCRIPTION	5VX1	5VX2	REMARKS
1	5VS-W2587-00	MASTER CYLINDER SUB ASSY	1	1	
2	5VS-W0041-00	.CYLINDER KIT, MASTER	1	1	
3	5VS-25852-00	.CAP, RESERVOIR	1	1	
4	5VS-25855-00	.BUSH, DIAPHRAGM	1	1	
5	5VS-25854-00	.DIAPHRAGM, RESERVOIR	1	1	
6	5VS-2589H-00	.SCREW	2	2	
7	5VS-2589F-00	BOLT, LEVER	1	1	
8	95617-06100	NUT, U	1	1	
9	5VS-83922-00	LEVER 2	1	1	
10	5VS-26332-00	BOLT	2	2	
11	5VS-25867-00	BRACKET, MASTER CYLINDER	1	1	
12	4HM-83980-00	FRONT STOP SWITCH ASSY	1	1	
13	98502-04012	SCREW, PAN HEAD	1	1	
14	92902-04100	WASHER, SPRING	1	1	
15	92902-04600	WASHER, PLATE	1	1	
16	5VX-25872-00	HOSE, BRAKE 1	1	1	
17	90401-10159	BOLT, UNION	3	3	
18	90201-10118	WASHER, PLATE	6	6	
19	1UA-82591-00	BAND	1	1	
20	5SL-25876-00	HOLDER, BRAKE HOSE 2	1	1	
21	95807-06010	BOLT, FLANGE	1	1	
22	5VX-25875-00	HOLDER, BRAKE HOSE 1	1	1	
23	95027-06025	BOLT, FLANGE	1	1	
24	95027-06025	BOLT, FLANGE	1	1	

FIG. 35 STAND & FOOTREST

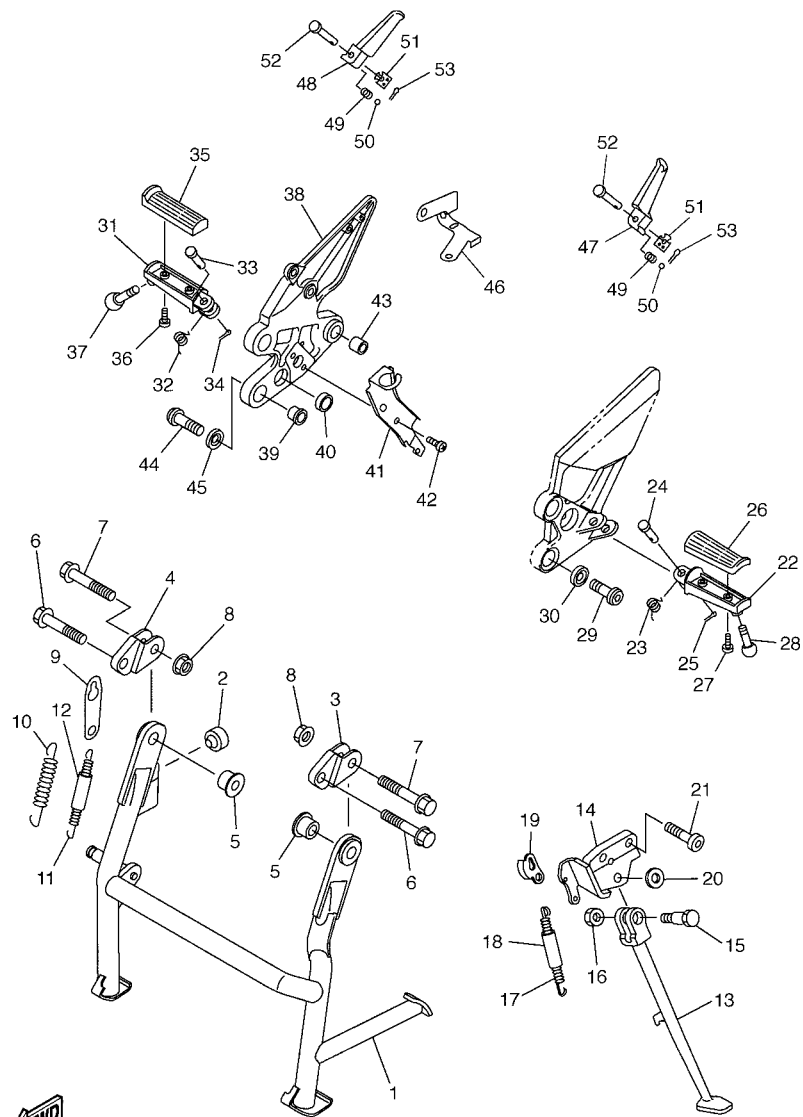

5VX1351-C350

REF. NO.	PART NO.	DESCRIPTION	5VX1	5VX2	REMARKS
1	5VX-27111-02	STAND, MAIN	1	1	
2	4GL-27114-00	STOPPER, MAIN STAND	1	1	
3	5VX-27151-02	BRACKET, MAIN STAND	1	1	
4	5VX-27152-02	BRACKET, MAIN STAND 2	1	1	
5	5VX-27113-00	COLLAR, MAIN STAND	2	2	
6	90105-10083	BOLT, FLANGE	2	2	
7	90105-10091	BOLT, FLANGE	2	2	
8	95707-10500	NUT, FLANGE	4	4	
9	5VX-27115-00	LINK, MAIN STAND	1	1	
10	90506-50001	SPRING, TENSION	1	1	
11	90506-26008	SPRING, TENSION	1	1	
12	90445-170K9	HOSE (L60)	1	1	
13	5VX-27311-00	STAND, SIDE	1	1	
14	5VX-27321-00	BRACKET, SIDE STAND	1	1	
15	90109-10011	BOLT	1	1	
16	90185-10037	NUT, SELF-LOCKING	1	1	
17	90506-23007	SPRING, TENSION	1	1	
18	5VX-27351-00	GUIDE, SIDE STAND	1	1	
19	5VX-27315-00	LINK, SIDE STAND	1	1	
20	90201-12021	WASHER, PLATE	1	1	
21	90110-10010	BOLT, HEXAGON SOCKET HEAD	2	2	
22	4BH-27451-01	FOOTREST	1	1	
23	90508-20572	SPRING, TORSION	1	1	
24	91701-08040	PIN, CLEVIS	1	1	
25	91401-25015	PIN, COTTER	1	1	
26	3YX-27413-00	COVER, FOOTREST	1	1	
27	90157-05079	SCREW, PAN HEAD	2	2	

FIG. 35 STAND & FOOTREST

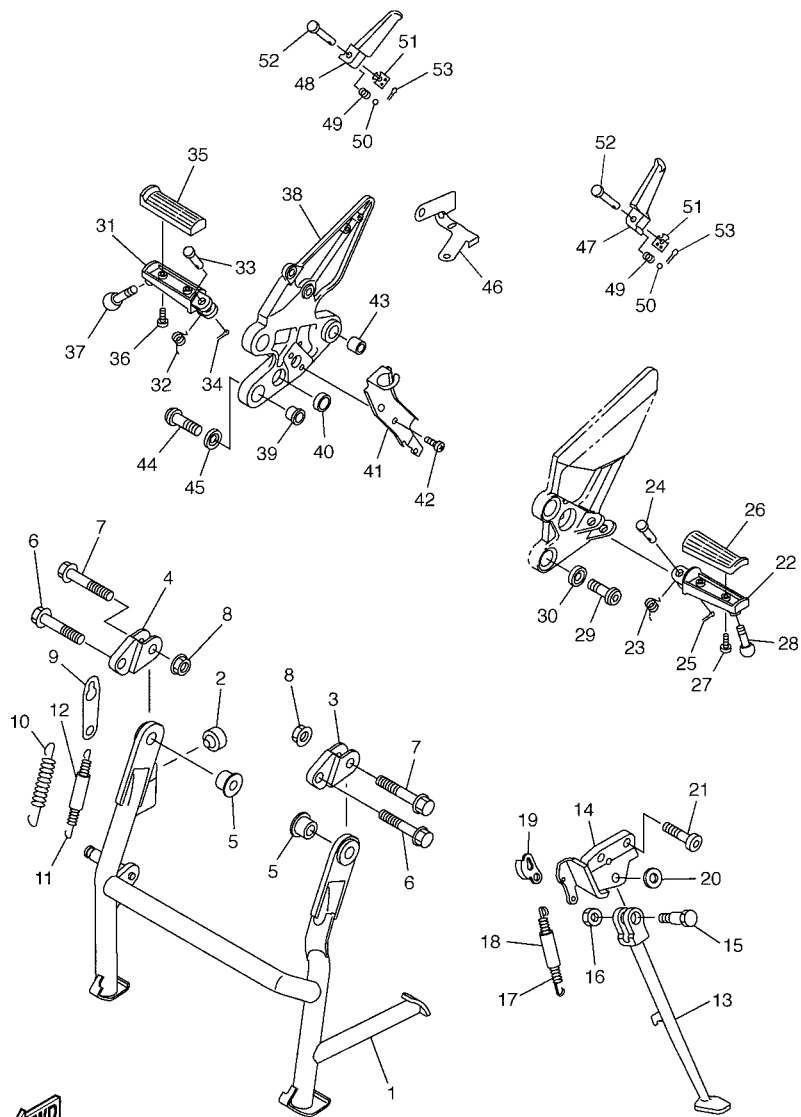

5VX1351-C350

REF. NO.	PART NO.	DESCRIPTION	5VX1	5VX2	REMARKS
28	90109-083E2	BOLT	1	1	
29	90110-08220	BOLT, HEXAGON SOCKET HEAD	2	2	
30	90209-08295	WASHER	2	2	
31	4BH-27461-01	FOOTREST	1	1	
32	90508-20572	SPRING, TORSION	1	1	
33	91701-08040	PIN, CLEVIS	1	1	
34	91401-25015	PIN, COTTER	1	1	
35	3YX-27413-00	COVER, FOOTREST	1	1	
36	90157-05079	SCREW, PAN HEAD	2	2	
37	90109-083E2	BOLT	1	1	
38	5VX-27443-00	BRACKET 3	1	1	
39	5VX-27424-00	DAMPER, FOOTREST 2	2	2	
40	5VX-27114-00	STOPPER, MAIN STAND	1	1	
41	5VX-2144G-00	STAY, STOP SWITCH	1	1	
42	98507-06008	SCREW, PAN HEAD	2	2	
43	90383-14001	BUSH, FORMED	1	1	
44	90110-08220	BOLT, HEXAGON SOCKET HEAD	2	2	
45	90209-08295	WASHER	2	2	
46	5VX-2587A-00	HOLDER, BREAK HOSE	1	1	
47	3VR-27431-01	FOOTREST, REAR 1	1	1	
48	3VR-27441-01	FOOTREST, REAR 2	1	1	
49	90501-12743	SPRING, COMPRESSION	2	2	
50	93501-04011	BALL	2	2	
51	5VX-27437-00	WASHER, SPECIAL	2	2	
52	90240-08063	PIN, CLEVIS	2	2	
53	91401-25015	PIN, COTTER	2	2	

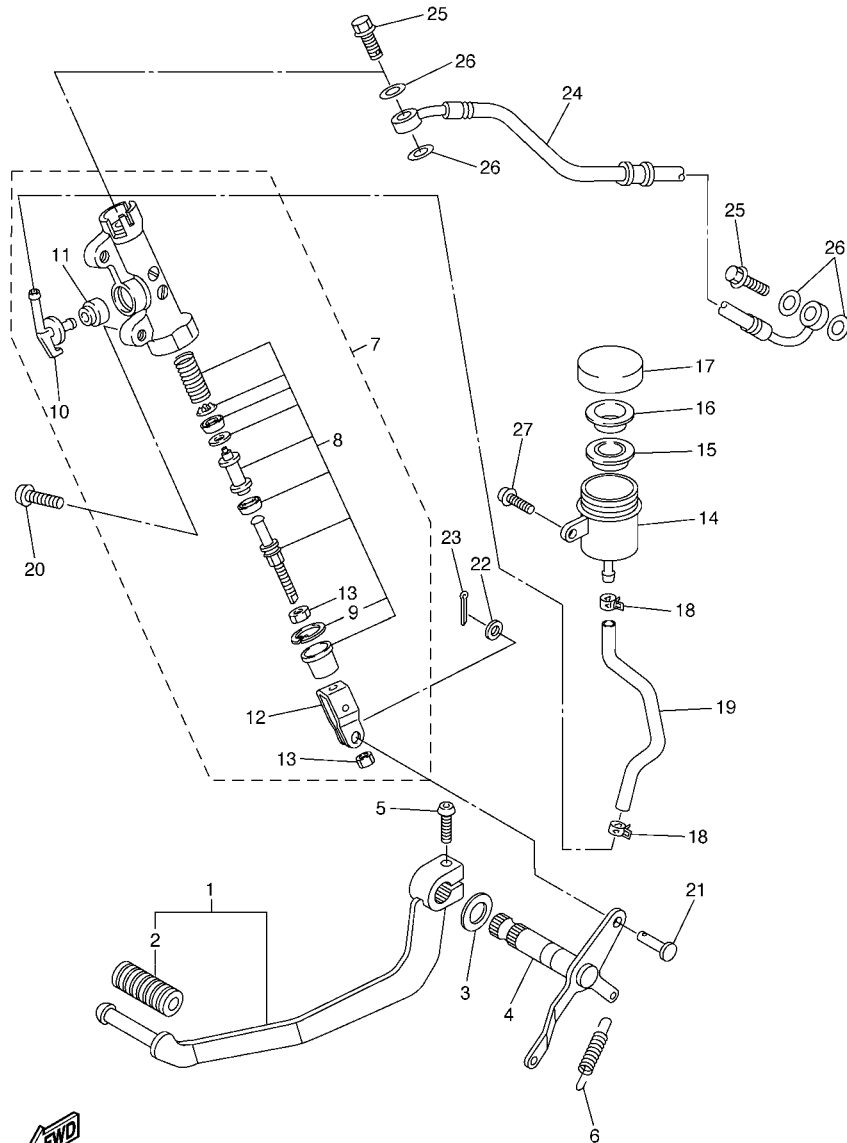

5VX1351-C360

FIG. 36 REAR MASTER CYLINDER

REF. NO.	PART NO.	DESCRIPTION	5VX1	5VX2	REMARKS
1	5VX-27200-00	PEDAL, BRAKE	1	1	
2	5EB-18113-00	.COVER, SHIFT PEDAL	1	1	
3	90201-14215	WASHER, PLATE	1	1	
4	5VX-27212-00	SHAFT, BRAKE PEDAL	1	1	
5	92014-06020	BOLT, BUTTON HEAD	1	1	
6	90506-20223	SPRING, TENSION	1	1	
7	5VX-2583V-00	RR. MASTER CYLINDER ASSY.	1	1	
8	5VX-W0042-50	.CYLINDER KIT, MASTER	1	1	
9	3LN-2585G-00	..CIRCLIP	1	1	
10	5VX-2582A-00	.JOINT	1	1	
11	4BP-2585F-00	.BUSH	1	1	
12	4BP-27222-01	.JOINT	1	1	
13	90170-08010	.NUT	2	2	
14	5SL-25894-00	TANK, RESERVOIR	1	1	
15	5SL-25854-00	DIAPHRAGM, RESERVOIR	1	1	
16	5SL-25855-00	BUSH,DIAPHRAGM	1	1	
17	5SL-25852-00	CAP, RESERVOIR	1	1	
18	90467-090A1	CLIP	2	2	
19	5VX-25895-00	HOSE, RESERVOIR	1	1	
20	92014-08020	BOLT, BUTTON HEAD	2	2	
21	90240-08124	PIN, CLEVIS	1	1	
22	90201-08083	WASHER, PLATE	1	1	
23	91401-20012	PIN, COTTER	1	1	
24	5VX-2581K-00	HOSE, BRAKE 5	1	1	
25	90401-10159	BOLT, UNION	2	2	
26	90201-10118	WASHER, PLATE	4	4	
27	90119-06044	BOLT, WITH WASHER	1	1	

FIG. 37 COWLING 1

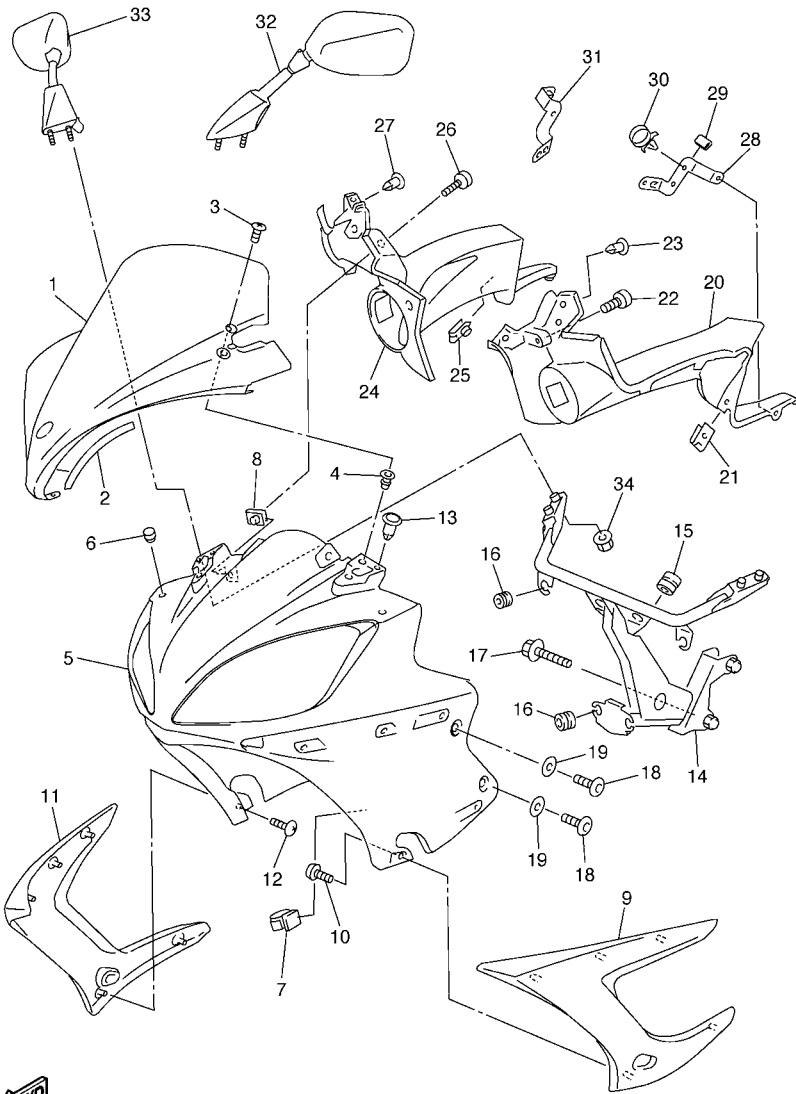

5VX1351-C370

REF. NO.	PART NO.	DESCRIPTION	5VX1	5VX2	REMARKS
1	5VX-28381-00	WINDSHIELD	1		
	5VX-28381-30	WINDSHIELD		1	
2	5VX-28376-00	TRIM	2	2	
	90150-05023	SCREW, ROUND HEAD	5	5	
4	90179-05523	NUT	5	5	
	5VX-2835G-10	BODY, FRONT UPPER 1	1	1	FOR S3
5	5VX-2835G-00	BODY, FRONT UPPER 1	1	1	FOR DPBML, DNBME
	1J7-21717-00	DAMPER	2	2	
7	90464-54086	CLAMP	2	2	
	90183-05074	NUT, SPRING	2	2	
9	5VX-2830C-00-P0	VISOR, SIDE 1	1	1	UR S3
	5VX-2830C-00-P1	VISOR, SIDE 1	1	1	UR DPBML
	5VX-2830C-00-P2	VISOR, SIDE 1	1	1	UR DNBME
10	97707-50016	SCREW, TAPPING	4	4	
	5VX-2830D-00-P0	VISOR, SIDE 2	1	1	UR S3
11	5VX-2830D-00-P1	VISOR, SIDE 2	1	1	UR DPBML
	5VX-2830D-00-P2	VISOR, SIDE 2	1	1	UR DNBME
12	97707-50016	SCREW, TAPPING	5	5	
	90269-05049	RIVET	2	2	
14	5VX-28356-00	STAY 1	1	1	
	90480-14585	GROMMET	2	2	
16	90480-14229	GROMMET	4	4	
	95814-08035	BOLT, FLANGE	2	2	
18	90110-06200	BOLT, HEXAGON SOCKET HEAD	4	4	
	90202-06170	WASHER, PLATE	4	4	
20	5VX-2836K-10	PANEL, INNER 1	1	1	FOR S3
	5VX-2836K-00	PANEL, INNER 1	1	1	FOR DPBML, DNBME

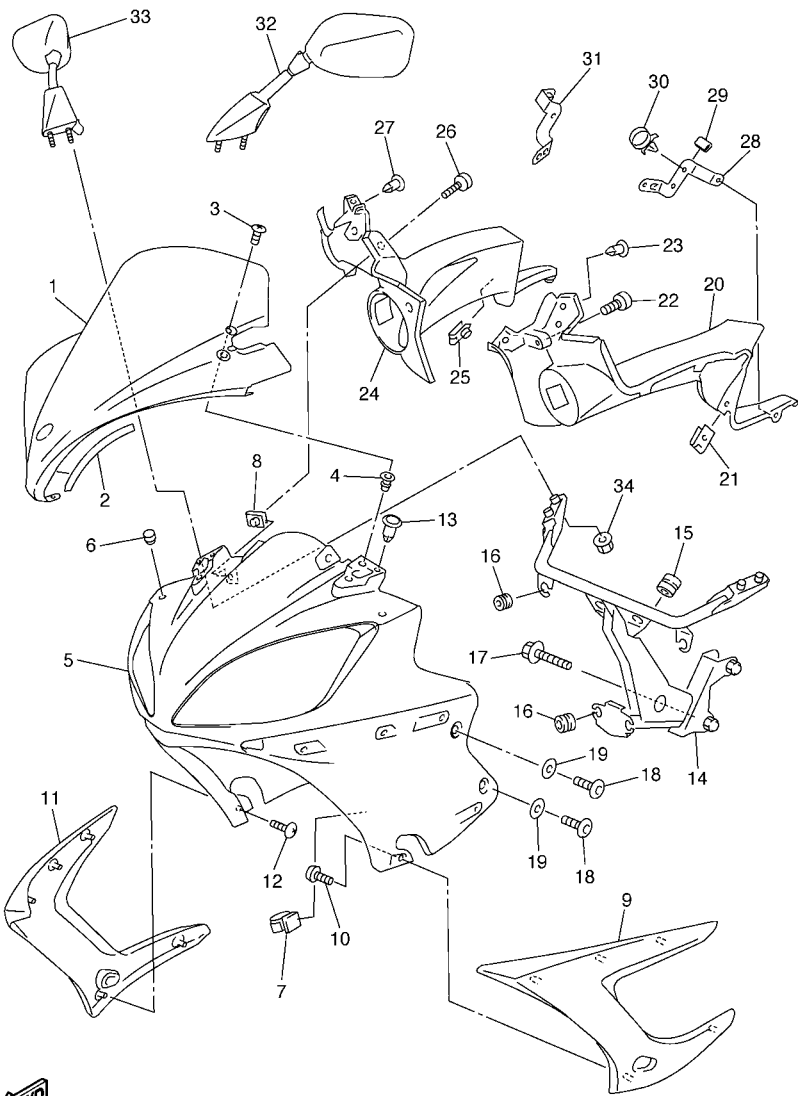

5VX1351-C370

FIG. 37 COWLING 1

REF. NO.	PART NO.	DESCRIPTION	5VX1	5VX2	REMARKS
21	90183-06053	NUT, SPRING	1	1	
22	90110-05201	BOLT, HEXAGON SOCKET HEAD	1	1	
23	90269-05049	RIVET	1	1	
24	5VX-2836L-10	PANEL, INNER 2	1	1	FOR S3
	5VX-2836L-00	PANEL, INNER 2	1	1	FOR DPBML,DNBME
25	90183-06053	NUT, SPRING	1	1	
26	90110-05201	BOLT, HEXAGON SOCKET HEAD	1	1	
27	90269-05049	RIVET	1	1	
28	5VX-2836A-00	BRACKET 1	1	1	
29	1FK-2171M-00	MOLE, SIDE COVER 2	1	1	
30	90464-16006	CLAMP	1	1	
31	5VX-2836E-00	BRACKET 2	1	1	
32	5VX-26280-00	REAR VIEW MIRROR ASSY (LEFT)	1	1	
33	5VX-26290-00	REAR VIEW MIRROR ASSY (RIGHT)	1	1	
34	95707-06500	NUT, FLANGE	4	4	

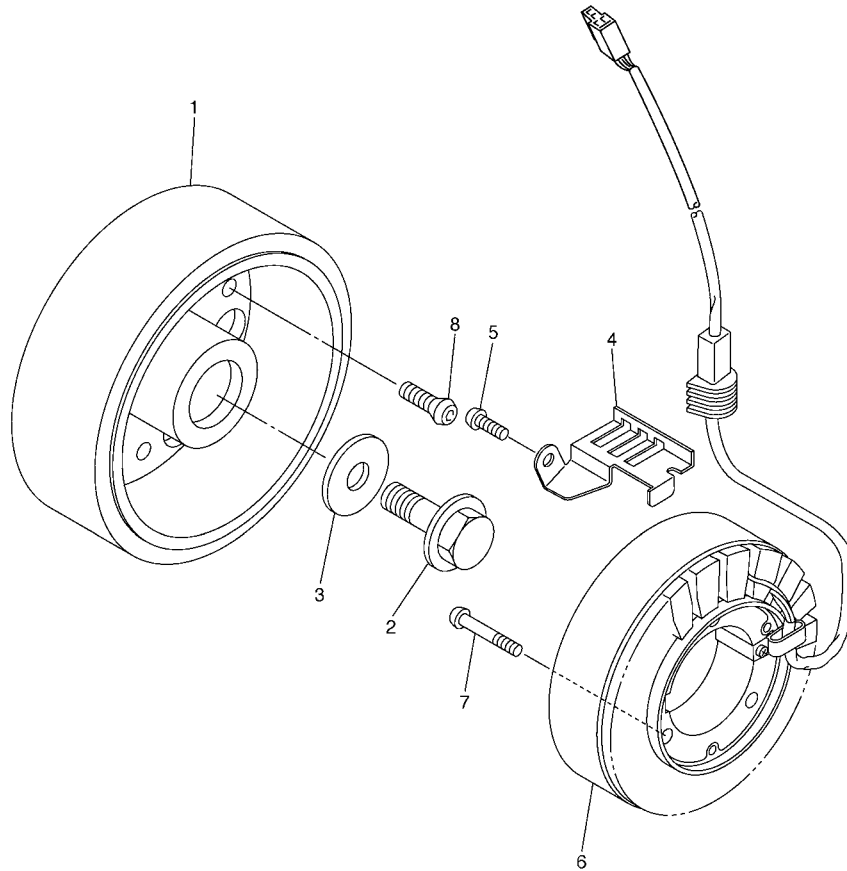

FIG. 38 GENERATOR

REF. NO.	PART NO.	DESCRIPTION	5VX1	5VX2				REMARKS
1	5VX-81450-00	ROTOR ASSY	1	1				
2	90105-126A8	BOLT, FLANGE	1	1				
3	90201-12008	WASHER, PLATE	1	1				
4	5VX-15484-00	CLAMP 2	1	1				
5	90149-06250	SCREW	1	1				
6	5VX-81410-00	STATOR ASSY	1	1				
7	90149-06019	SCREW	3	3				
8	90149-08003	SCREW	3	3				



5VX1351-C380

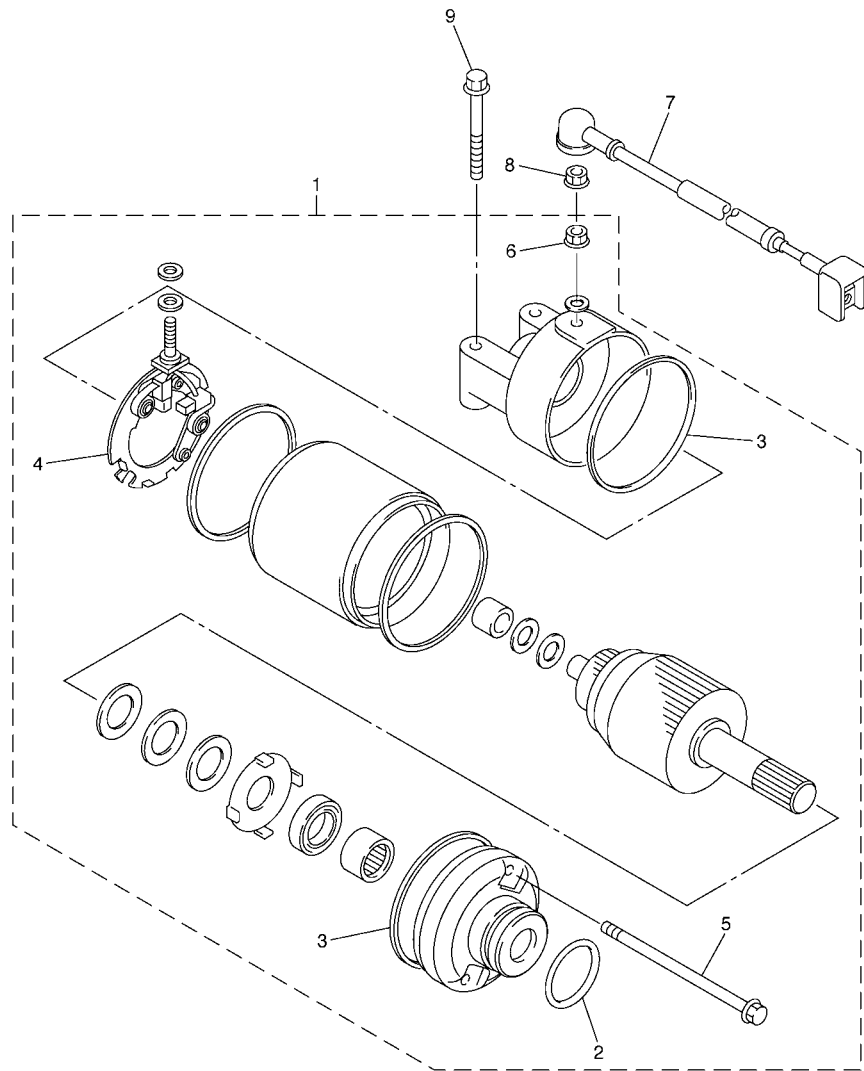
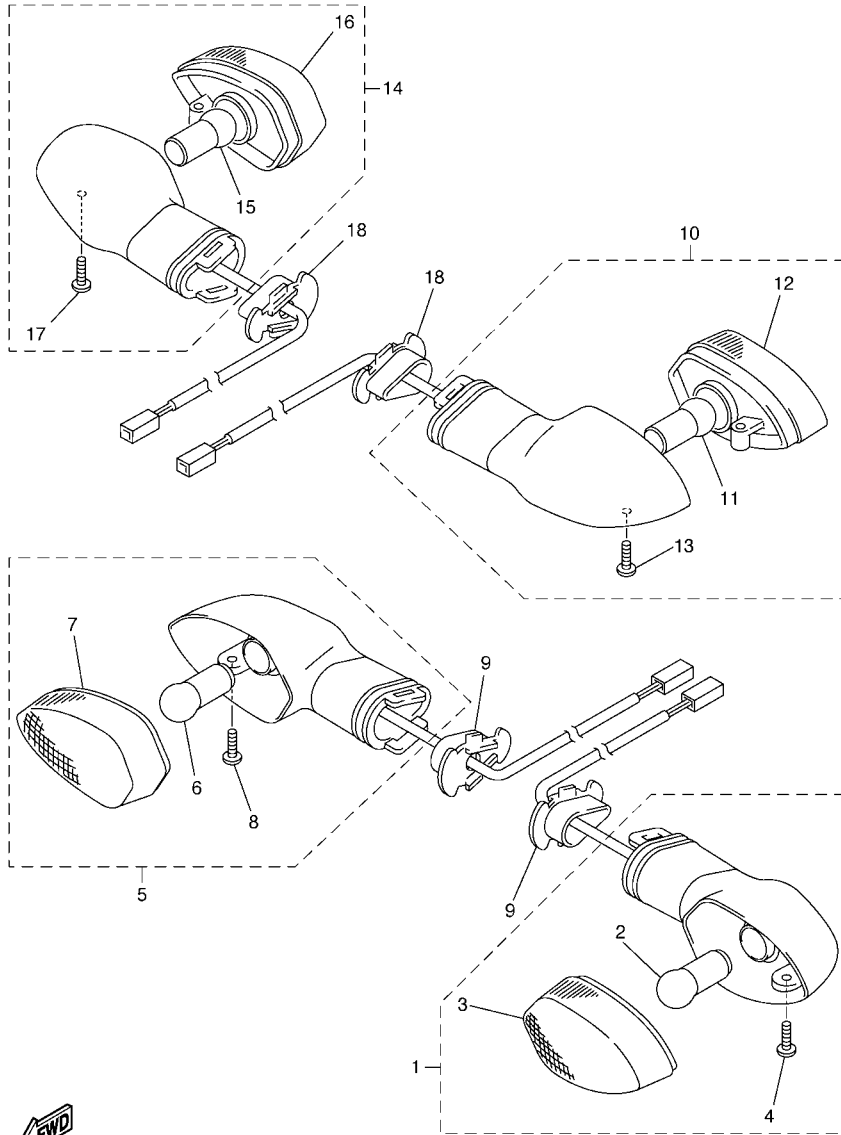

FIG. 39 STARTING MOTOR

REF. NO.	PART NO.	DESCRIPTION	5VX1	5VX2				REMARKS
1	5EB-81890-00	MOTOR ASSY	1	1				
2	1FK-81847-00	.O-RING	1	1				
3	4WP-81844-00	.GASKET	2	2				
4	4WP-81801-00	.BRUSH SET	1	1				
5	4WP-81826-00	.BOLT	2	2				
6	4XV-8182A-00	.NUT	1	1				
7	5VX-81815-00	CORD, STARTER MOTOR	1	1				
8	4XV-8182A-00	NUT	1	1				
9	95027-06040	BOLT, FLANGE	2	2				



5VX1351-C390



5PW1300-2410

FIG. 40 FLASHER LIGHT

REF. NO.	PART NO.	DESCRIPTION	5VX1	5VX2	REMARKS
1	5PW-83310-01	FRONT FLASHER LIGHT ASSY 1	1	1	
2	1KH-83311-00	.BULB (12V-10W)	1	1	
3	5PW-8333A-00	.LENS COMP	1	1	
4	97706-04012	.SCREW, TAPPING	1	1	
5	5PW-83320-01	FRONT FLASHER LIGHT ASSY 2	1	1	
6	1KH-83311-00	.BULB (12V-10W)	1	1	
7	5PW-8334A-00	.LENS COMP	1	1	
8	97706-04012	.SCREW, TAPPING	1	1	
9	5PW-83318-00	STAY, FLASHER 1	2	2	
10	5VX-83330-00	REAR FLASHER LIGHT ASSY 1	1	1	
11	1KH-83311-00	.BULB (12V-10W)	1	1	
12	5PW-8334A-00	.LENS COMP	1	1	
13	97706-04012	.SCREW, TAPPING	1	1	
14	5VX-83340-00	FLASHER LIGHT ASSY 2	1	1	
15	1KH-83311-00	.BULB (12V-10W)	1	1	
16	5PW-8333A-00	.LENS COMP	1	1	
17	97706-04012	.SCREW, TAPPING	1	1	
18	5PW-83318-00	STAY, FLASHER 1	2	2	

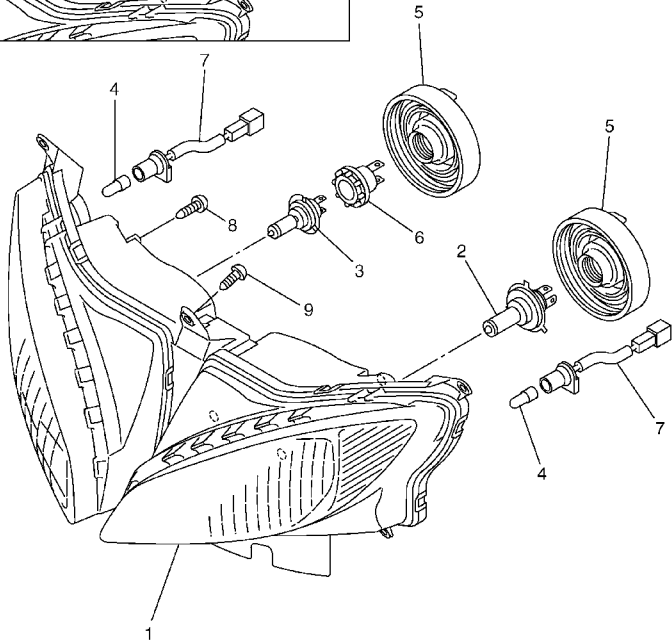
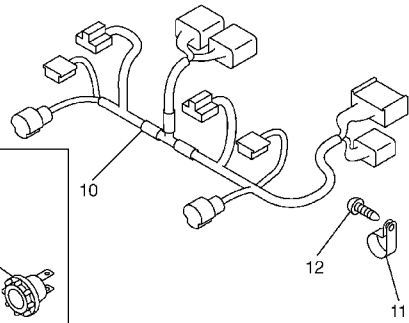
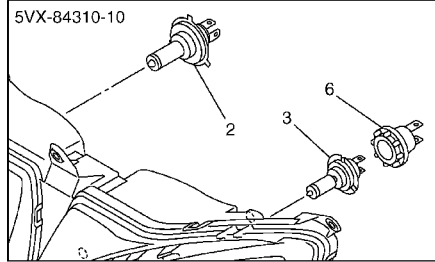

5VX1351-C421

FIG. 42 HEADLIGHT

REF. NO.	PART NO.	DESCRIPTION	5VX1	5VX2				REMARKS
1	5VX-84310-00	HEADLIGHT UNIT ASSY	1					
	5VX-84310-10	HEADLIGHT UNIT ASSY	1	1				FOR GBR,ZAF
2	8G9-84314-00	BULB (12V-60/55W)	1	1				(H4)HALOGEN
3	4SV-84314-00	BULB (12V-55W)	1	1				(H7)HALOGEN
4	4SV-84347-00	BULB (12V-5W)	2	2				
5	5LV-84397-00	COVER, SOCKET	2	2				
6	4SV-84350-00	SOCKET CORD ASSY 2	1	1				
7	5VX-84312-00	HOLDER, SOCKET	2	2				
8	90164-05014	SCREW, TAPPING	4	4				
9	97707-50016	SCREW, TAPPING	5	5				
10	5VX-84359-00	CORD, HEADLIGHT	1					
	5VX-84359-10	CORD, HEADLIGHT	1	1				FOR GBR,ZAF
11	90464-18029	CLAMP	1	1				
12	97707-50016	SCREW, TAPPING	1	1				

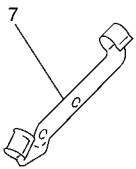
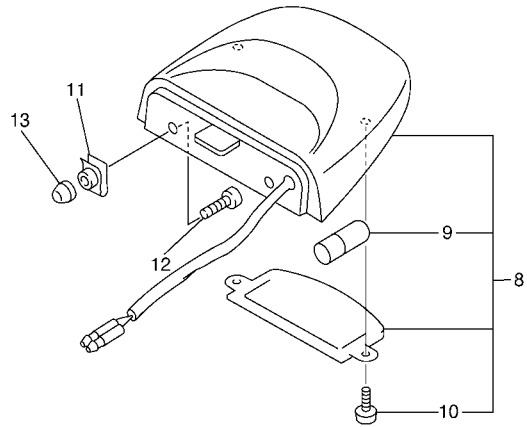
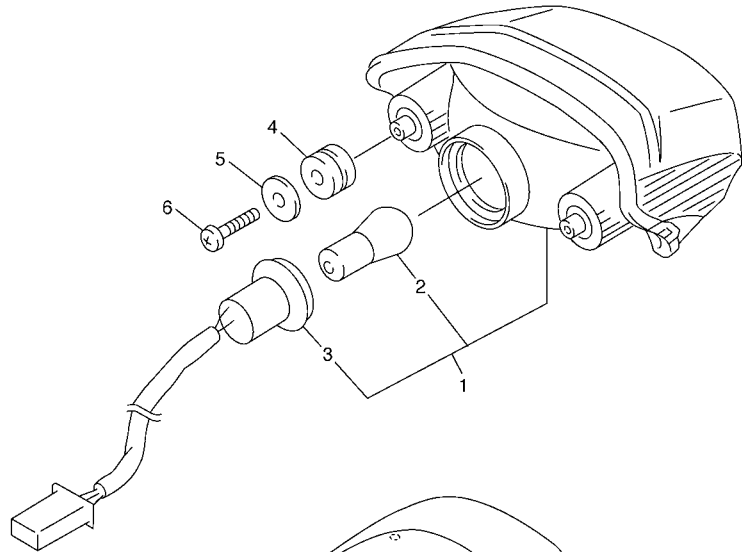

5VX1351-C430

FIG. 43 TAILLIGHT

REF. NO.	PART NO.	DESCRIPTION	5VX1	5VX2				REMARKS
1	5VX-84710-00	TAILLIGHT UNIT ASSY	1	1				
2	137-84714-60	.BULB (12V-21/5W)	1	1				
3	5VX-84735-00	.CORD ASSY	1	1				
4	90480-18276	GROMMET	2	2				
5	90201-06071	WASHER, PLATE	2	2				
6	97707-60016	SCREW, TAPPING	2	2				
7	5VX-21637-00	CLAMP, WIRE	1	1				
8	5VX-84745-00	LICENCE LIGHT UNIT ASSY	1	1				
9	4HC-84744-00	.BULB (12V-5W)	1	1				
10	97706-04012	.SCREW, TAPPING	2	2				
11	90183-05061	NUT, SPRING	2	2				
12	98907-05014	SCREW, BIND	2	2				
13	5VX-13569-00	PLUG, BLIND	2	2				

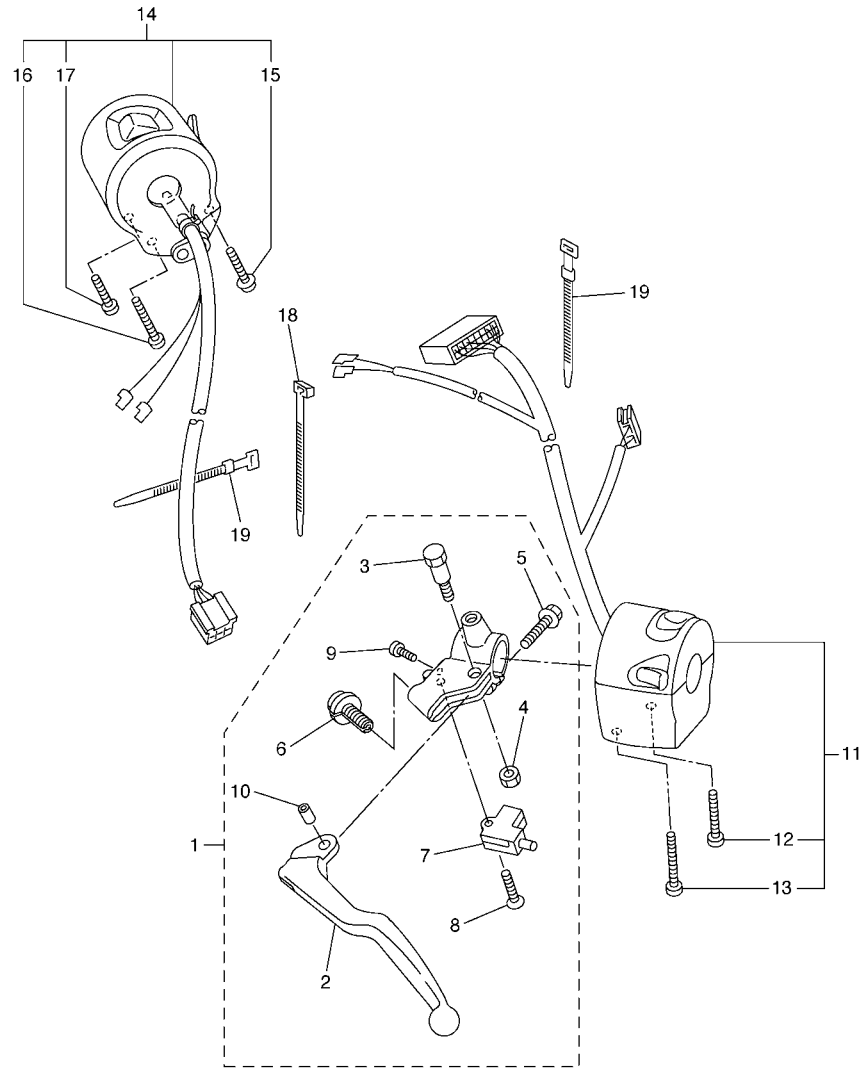
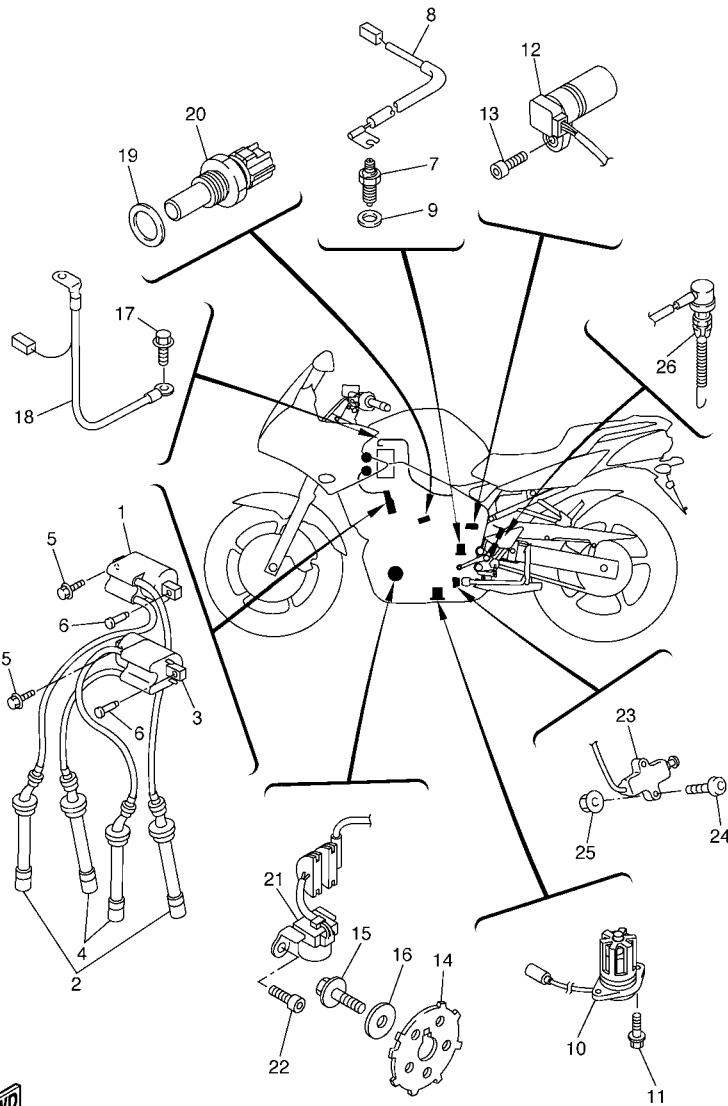

FIG. 44 HANDLE SWITCH & LEVER

REF. NO.	PART NO.	DESCRIPTION	5VX1	5VX2	REMARKS
1	5VX-82910-00	LEVER HOLDER ASSY (LEFT)	1	1	
2	5EB-83912-02	.LEVER 1	1	1	
3	4XV-83945-00	.BOLT, LEVER	1	1	
4	95607-06100	.NUT, U	1	1	
5	95027-06020	.BOLT, FLANGE	1	1	
6	5LV-83951-00	.BOLT, CABLE ADJUSTING	1	1	
7	3YX-82917-01	.SWITCH	1	1	
8	98704-03020	.SCREW, FLAT HEAD	1	1	
9	98507-04010	.SCREW, PAN HEAD	1	1	
10	5JJ-83913-00	.COLLAR, LEVER 1	1	1	
11	5VX-83969-00	SWITCH, HANDLE 5	1	1	
12	98507-05030	.SCREW, PAN HEAD	1	1	
13	98507-05045	.SCREW, PAN HEAD	1	1	
14	5VX-83975-00	SWITCH, HANDLE 2	1	1	
15	97607-05255	.SCREW, WITH WASHER	1	1	
16	98507-05045	.SCREW, PAN HEAD	1	1	
17	98507-05020	.SCREW, PAN HEAD	1	1	
18	1UA-82591-00	BAND	1	1	
19	437-83936-01	BAND, SWITCH CORD	2	2	



5VX1351-C440



5VX1351-C450

FIG. 45 ELECTRICAL 1

REF. NO.	PART NO.	DESCRIPTION	5VX1	5VX2				REMARKS
1	5VX-82310-00	IGNITION COIL ASSY	1	1				
2	5VX-82370-00	PLUG CAP ASSY	2	2				
3	5VX-82320-00	IGNITION COIL ASSY	1	1				
4	5VX-82370-00	PLUG CAP ASSY	2	2				
5	90105-06557	BOLT, FLANGE	2	2				
6	90269-06010	RIVET	2	2				
7	3GB-82540-01	NEUTRAL SWITCH ASSY	1	1				
8	5VX-82541-00	WIRE, LEAD	1	1				
9	90430-10148	GASKET	1	1				
10	5VX-85720-00	OIL LEVEL GAUGE ASSY	1	1				
11	95027-06016	BOLT, FLANGE	2	2				
12	5EB-83755-00	SENSOR, SPEED	1	1				
13	91317-06016	BOLT	1	1				
14	5VX-81673-00	ROTOR	1	1				
15	90105-08386	BOLT, FLANGE	1	1				
16	90201-08753	WASHER, PLATE	1	1				
17	95027-06012	BOLT, FLANGE	1	1				
18	5VX-82116-00	WIRE, MINUS LEAD	1	1				
19	90201-12790	WASHER, PLATE	1	1				
20	8CC-85790-01	THERMOSENSOR ASSY	1	1				
21	5VX-81670-00	PICK-UP ASSY	1	1				
22	91317-06016	BOLT	2	2				
23	5VS-82566-60	SWITCH, SIDE STAND	1	1				
24	92017-05025	BOLT, BUTTON HEAD	2	2				
25	95607-05200	NUT, U FLANGE	2	2				
26	5VX-82530-00	STOP SWITCH ASSY	1	1				

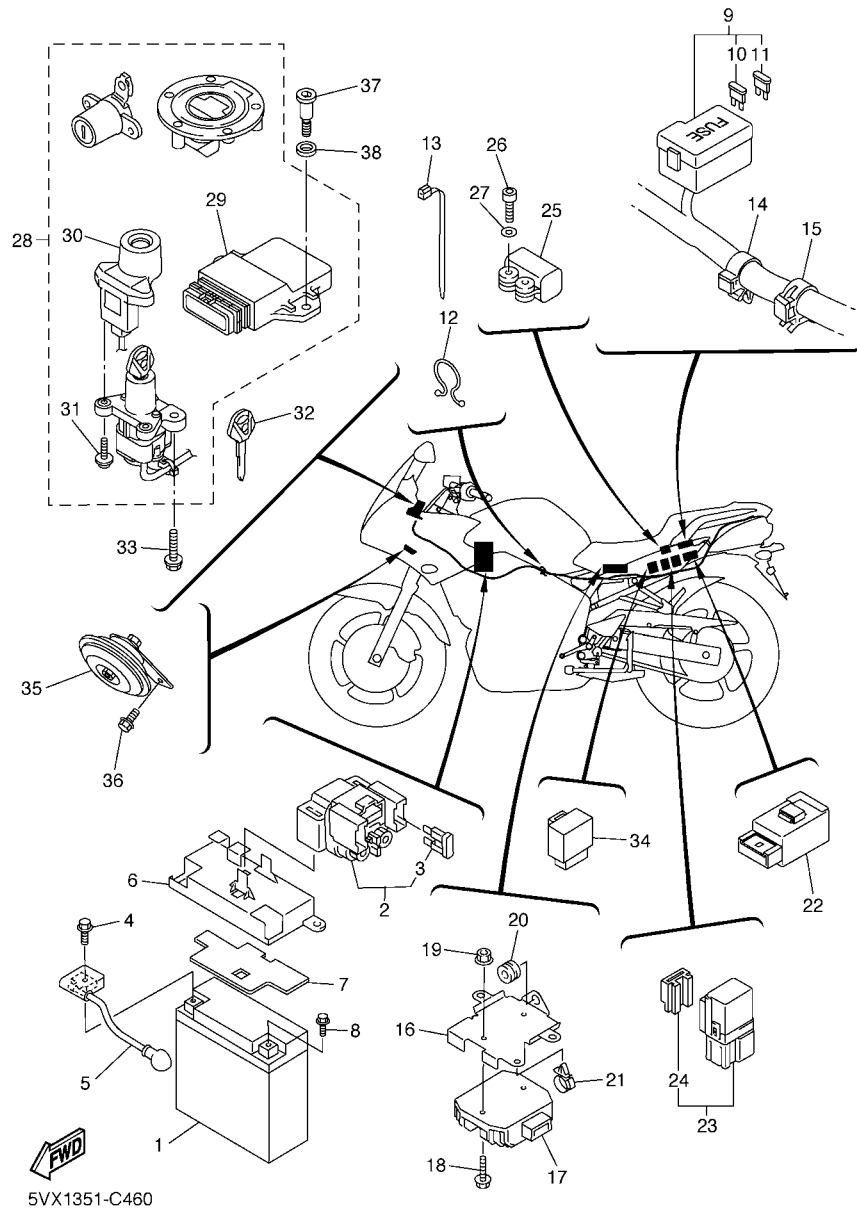

FIG. 46 ELECTRICAL 2

REF. NO.	PART NO.	DESCRIPTION	5VX1	5VX2	REMARKS
1	4TX-82100-02	BATTERY ASSY (GS GT12B-4)	1	1	
2	4BH-81940-00	STARTER RELAY ASSY	1	1	
3	1AE-82151-00	.FUSE (30A-BL)	2	2	
4	95027-06008	BOLT, FLANGE	1	1	
5	5VX-82115-00	WIRE, PLUS LEAD	1	1	
6	5VX-2124E-00	COVER, BATTERY	1	1	
7	5VX-82123-00	SEAT, BATTERY	1	1	
8	95027-06008	BOLT, FLANGE	1	1	
9	5VX-82590-00	WIRE HARNESS ASSY	1	1	
10	5JJ-82151-30	.FUSE (10A-BL)	6	6	
11	5JJ-82151-20	.FUSE (20A-BL)	3	3	
12	90464-14058	CLAMP	1	1	
13	90464-13077	CLAMP	1	1	
14	90464-16006	CLAMP	3	3	
15	90464-15192	CLAMP	2	2	
16	5VX-2128A-00	BRACKET, REGULATOR	1	1	
17	5VX-81960-00	RECTIFIER & REGULATOR ASSY	1	1	
18	95807-06020	BOLT, FLANGE	2	2	
19	95707-06500	NUT, FLANGE	2	2	
20	90480-11005	GROMMET	1	1	
21	90464-13249	CLAMP	1	1	
22	5VX-819B0-00	RELAY SUB-ASSY	1	1	
23	5EA-81950-20	RELAY ASSY	2	2	
24	5EA-81952-00	.HOLDER, RELAY	1	1	
25	5PS-82576-01	EMERGENCY STOP SWITCH ASSY	1	1	
26	91317-04025	BOLT	2	2	
27	90201-047A2	WASHER, PLATE	2	2	

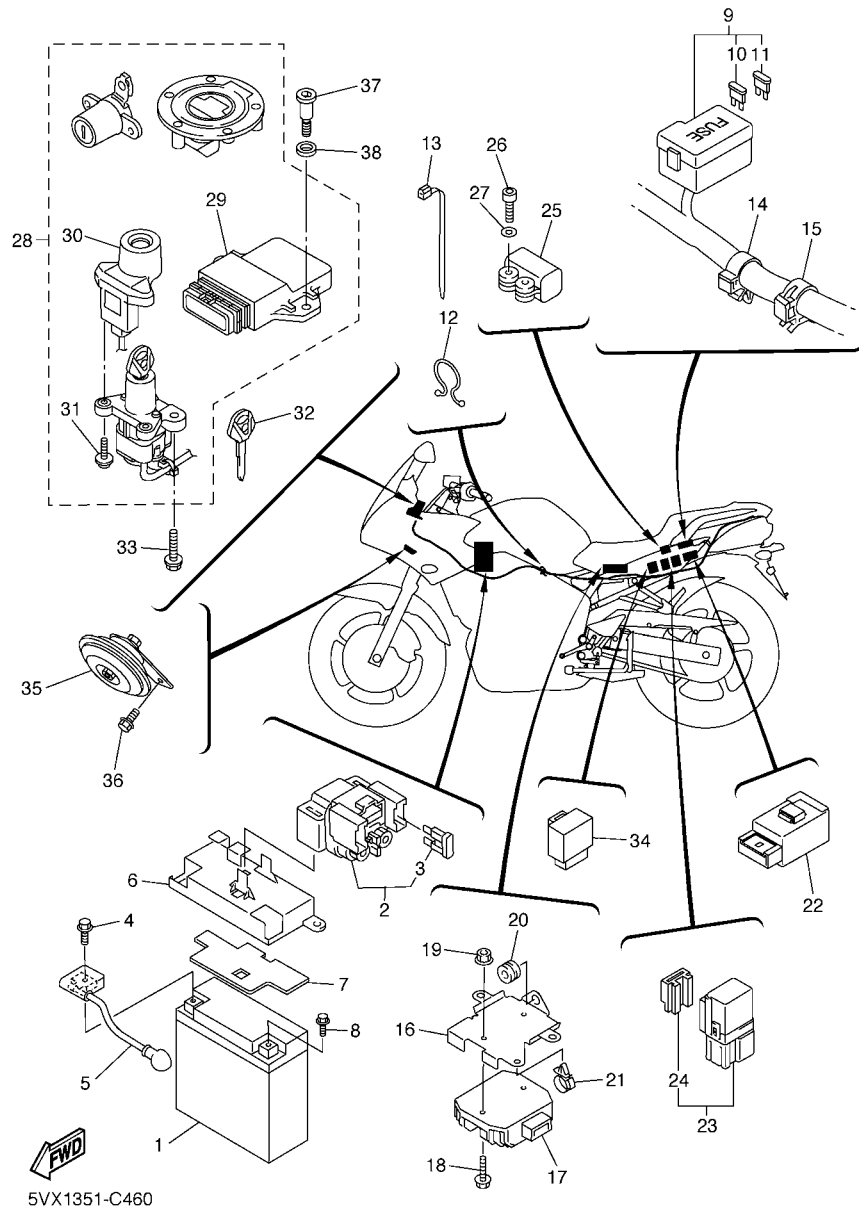

FIG. 46 ELECTRICAL 2

REF. NO.	PART NO.	DESCRIPTION	5VX1	5VX2	REMARKS
28	5VX-W8250-01	MAIN SW. IMMOBILIZER KIT	1	1	
29	5VX-8591A-00	.ENGINE CONTROL UNIT ASSY	1	1	
30	5VX-8255P-00	.IMMOBILIZER. UNIT COMP.	1	1	
31	5SL-82113-00	.SCREW	2	2	
32	5SL-82511-08	BLANK KEY	1	1	AP
33	90109-080G5	BOLT	2	2	
34	3XV-83350-21	FLASHER RELAY ASSY	1	1	
35	5VX-83371-00	HORN	1	1	
36	95807-06010	BOLT, FLANGE	1	1	
37	90109-06055	BOLT	2	2	
38	5VX-21778-00	DAMPER, LOCATING 1	2	2	

NUMERICAL INDEX

PART NO.	GRID NO.	PART NO.	GRID NO.	PART NO.	GRID NO.	PART NO.	GRID NO.	PART NO.	GRID NO.	PART NO.	GRID NO.
5VX-11101-00	B - 2	1HX-12168-U1	B - 4	5VX-12578-00	B - 8	5VX-14421-00	B - 12	5VX-15484-00	E - 15	136-18542-00	C - 13
4KG-1111G-00	B - 2	1HX-12168-W1	B - 4	4NK-12579-00	B - 7	5CA-14435-00	B - 12	5SL-15512-00	C - 8	5VX-21110-00	D - 2
5EB-11133-10	B - 2	1HX-12168-Y1	B - 4	5VX-12579-00	B - 8	5VX-14451-00	B - 12	5MT-15515-00	C - 8	5VX-21110-10	D - 2
5SL-11165-00	C - 4	1HX-12169-11	B - 4	5VX-12581-00	B - 7	5VX-14452-00	B - 12	5EB-15521-00	C - 8	5PW-2117K-00	E - 2
5VX-11181-00	B - 2	1HX-12169-31	B - 4	5SL-12588-01	B - 7	5VX-14453-00	B - 12	5SL-15590-00	C - 8	5VX-2117M-01	D - 3
5VX-11191-00	B - 2	1HX-12169-50	B - 5	5VX-12589-00	B - 9	5VX-14463-00	B - 12	5VX-16150-00	C - 9	5VX-21190-00	D - 2
5SL-11193-00	B - 2	1HX-12169-70	B - 5	5EB-12822-00	B - 11	5VX-14565-00	B - 13	5EB-16154-00	C - 9	5VX-21228-00	D - 7
214-11198-01	B - 11	1HX-12169-90	B - 5	5EB-13161-00	B - 10	5VX-14602-00	C - 2	1AE-16164-00	C - 9	5VX-21238-00	D - 2
5SL-11411-00	B - 3	1HX-12169-E0	B - 5	5EB-1316E-00	B - 10	3YF-14613-01	C - 2	4FN-16321-00	C - 9	5VX-21239-00	D - 2
5EB-11416-00	B - 3	1HX-12169-G0	B - 5	5MT-13300-00	B - 10	5VX-1467K-00	C - 2	4H7-16321-02	C - 9	5VX-21249-00	D - 3
5EB-11416-10	B - 3	1HX-12169-J0	B - 5	5SL-13410-00	B - 10	5VX-14708-10	C - 2	168-16324-00	C - 9	5VX-2124E-00	F - 9
5EB-11416-20	B - 3	1HX-12169-L0	B - 5	5VX-13414-00	B - 11	5VX-14710-00	C - 2	3J2-16324-00	C - 9	5VX-21268-00	D - 2
5EB-11416-30	B - 3	1HX-12169-N0	B - 5	5EB-13415-00	B - 10	3XW-14714-00	C - 2	5VX-16340-00	C - 9	5VX-21279-00	D - 2
5EB-11416-A0	B - 3	1HX-12169-T0	B - 5	5JW-13416-00	B - 10	5EB-14714-01	C - 2	132-16346-00	C - 14	5VX-21289-00	D - 2
5SL-11603-00	B - 3	5VX-12170-00	B - 6	5VX-13417-00	B - 11	5JW-14723-00	B - 15	5EB-16351-01	C - 9	5VX-2128A-00	F - 9
5SL-11631-00	B - 3	5VX-12176-00	B - 6	5VX-13418-00	C - 4	5VX-14740-00	C - 2	5EB-16356-01	C - 9	5VX-2135F-00	D - 3
5EB-11633-00	B - 3	5VX-12180-00	B - 6	5GH-13440-10	B - 11	4FB-14766-00	C - 2	5VX-16371-00	C - 9	5VX-21446-00	C - 2
5SL-11650-00	B - 3	5SL-12210-10	B - 6	5EB-13470-00	B - 11	5VX-14807-00	B - 14	5VX-16382-00	C - 9	5VX-21446-10	C - 3
5SL-11654-00	B - 3	4FM-12213-00	B - 6	4JH-13473-00	B - 11	5SL-1482K-00	B - 2	5SL-17121-00	C - 11	5VX-2144G-00	E - 11
5SL-11656-00	B - 3	5SL-12214-00	B - 6	5EB-13475-00	B - 11	5VX-14840-00	B - 15	5SL-17131-20	C - 11	5VX-21511-00	D - 4
5SL-11656-10	B - 3	5EL-12228-00	B - 6	3KS-13490-00	B - 11	5VX-14881-00	B - 15	5VX-17151-00	C - 11	5VX-21511-10	D - 4
5SL-11656-20	B - 3	5BE-12241-00	B - 2	5VX-13533-00	B - 14	5VX-14882-00	B - 15	5SL-17161-00	C - 11	5VX-21575-00	D - 4
5SL-11656-30	B - 3	5EB-12251-00	B - 6	68V-13533-00	B - 13	5VX-14883-00	B - 15	5SL-17211-00	C - 12	5VX-2161G-00	D - 5
5EB-12111-00	B - 4	5EB-12252-10	B - 6	5VX-13569-00	F - 6	5SL-14890-00	B - 2	5VX-17221-00	C - 11	5VX-21621-00	D - 5
5EB-12113-00	B - 4	5VX-12405-00	B - 8	5SL-13586-01	B - 12	5SL-14899-00	B - 2	5SL-17231-00	C - 12	5VX-21621-10	D - 5
5EB-12114-00	B - 4	5VX-1240J-00	B - 8	5SL-13596-01	B - 12	3UH-14937-00	B - 13	5SL-17241-00	C - 11	5VX-21629-00	D - 5
5SL-12116-00	B - 4	5SL-12410-00	B - 8	5VX-13750-00	B - 13	5VX-14987-00	B - 13	5VX-17251-00	C - 12	5VX-21637-00	F - 6
5EB-12117-00	B - 4	5VX-12413-00	B - 8	5VX-13761-00	B - 13	5VX-15100-00	C - 4	5VX-17261-00	C - 11	5VX-21639-00	D - 4
1HX-12118-00	B - 4	5VX-12421-00	B - 7	5EB-13898-00	B - 10	11H-15138-00	B - 2	5SL-17411-00	C - 11	5VX-2163A-00	D - 8
4TV-12119-00	B - 4	5VX-12422-00	B - 7	5VX-13907-00	D - 14	5EB-15155-00	C - 4	5SL-17421-00	C - 11	5VX-2164F-00	D - 6
5SL-12121-00	B - 4	1KT-12437-00	B - 8	5VX-13971-00	D - 14	5EB-15163-01	C - 11	278-17424-01	C - 12	5VX-2164H-00	D - 5
5EB-12124-01	B - 4	11H-12438-10	B - 7	5VX-13982-00	B - 14	36Y-15189-00	C - 4	5VX-17460-00	C - 12	5VX-2164J-00	D - 5
5EB-12126-00	B - 4	5EB-12439-00	B - 7	5JW-14104-00	B - 13	5SL-15189-00	C - 4	5VX-18101-10	C - 14	5VX-21650-00	D - 9
5EB-12127-00	B - 4	5VX-1243A-00	B - 9	5VX-1410E-00	B - 13	3F9-15362-00	C - 6	5VX-18110-00	C - 14	5VX-21651-00	D - 4
5EB-12153-09	B - 5	5VX-1243E-00	B - 14	4KM-14137-00	B - 13	5EB-15362-00	C - 4	5VX-18112-00	C - 14	5VX-21665-00	D - 5
5EB-12153-20	B - 5	5VX-1244E-00	B - 8	3H1-14147-00	B - 13	5VX-15373-00	B - 12	5EB-18113-00	C - 14	5VX-21669-00	D - 4
5EB-12153-30	B - 5	5VX-1244G-00	B - 9	5PS-14147-00	B - 13	5VX-15411-00	C - 6		E - 12	5VX-21710-00	D - 7
1HX-12168-00	B - 4	5EB-12450-00	B - 7	5VX-14148-00	B - 14	5VX-15413-01	C - 4	5VX-18115-00	C - 14	5VX-21710-10	D - 7
1HX-12168-20	B - 4	5VX-12461-00	B - 8	5VX-14149-00	B - 13	5VX-15416-00	C - 6	5VX-18116-00	C - 14	1J7-21717-00	E - 13
1HX-12168-40	B - 4	4FL-12462-00	B - 8	8CC-14216-10	B - 13	5VX-15418-00	C - 6	4XV-18127-00	C - 14	1FK-2171M-00	E - 14
1HX-12168-60	B - 4	5VX-12467-00	B - 8	3XV-14251-00	B - 13	5VX-15421-00	C - 6	5VX-18140-00	C - 14	5VX-21720-00	D - 7
1HX-12168-80	B - 4	5EB-12469-00	B - 7	5PW-14251-00	B - 13	5VX-15425-00	C - 6	5VX-18154-00	C - 14	5VX-21720-10	D - 7
1HX-12168-A0	B - 4	5GV-1246A-00	B - 7	5VX-14348-00	B - 13	5VX-15441-00	C - 7	5SL-18511-00	C - 13	5VX-21732-00	D - 4
1HX-12168-F0	B - 4	5GV-1246E-00	B - 7	5FL-14348-10	B - 13	5VX-15451-00	C - 6	5MT-18512-00	C - 13	5VX-21735-00	D - 4
1HX-12168-H1	B - 4		B - 8	5VX-14349-00	B - 14	5SL-15456-00	C - 6	5EB-18513-00	C - 13	5VX-2173M-00	D - 7
1HX-12168-K1	B - 4	5VX-12491-00	B - 9	5VX-14396-00	B - 13	5SL-15461-00	C - 6	4XV-18531-00	C - 13	5VX-2173N-00	D - 6
1HX-12168-M1	B - 4	1AA-12535-00	B - 8	5VX-14409-00	B - 12	5SL-15462-00	C - 4	5EB-18536-00	C - 13	5VX-2174X-00	D - 7
1HX-12168-R1	B - 4	5EB-12577-01	B - 7	5VX-14411-00	B - 12	5VX-15463-00	C - 7	5VX-18540-00	C - 13	5VX-2174Y-00	D - 7

NUMERICAL INDEX

PART NO.	GRID NO.	PART NO.	GRID NO.	PART NO.	GRID NO.	PART NO.	GRID NO.	PART NO.	GRID NO.	PART NO.	GRID NO.
5VX-21778-00	F - 10	5VX-24141-00	D - 15	5VX-2582A-00	E - 12	5VX-27114-00	E - 11	5VX-81815-00	F - 2	5VX-83371-00	F - 10
5VX-21779-00	D - 7	5EJ-2414H-00	B - 12	5VX-2582W-00	E - 7	5VX-27115-00	E - 10	4WP-81826-00	F - 2	5VX-83500-00	F - 4
5VX-2177F-00	D - 8		D - 2	5SL-25838-00	E - 7	5VX-27151-02	E - 10	4XV-8182A-00	F - 2	5VX-83500-10	F - 4
5VX-2177G-00	D - 2	5VX-24181-00	D - 14	5VX-2583V-00	E - 12	5VX-27152-02	E - 10	4WP-81844-00	F - 2	5EB-83755-00	F - 8
5VX-21781-00	D - 8	5VX-24183-00	D - 14	5SL-25852-00	E - 12	5VX-27200-00	E - 12	1FK-81847-00	F - 2	5EB-83912-02	F - 7
5VX-21781-20	D - 8	5VX-24191-00	D - 14	5VS-25852-00	E - 9	5VX-27212-00	E - 12	5EB-81890-00	F - 2	5JJ-83913-00	F - 7
5VX-21816-00	D - 7	5PW-24192-00	D - 14	5SL-25854-00	E - 12	4BP-27222-01	E - 12	4BH-81940-00	F - 9	5VS-83922-00	E - 9
26H-21828-00	D - 7	68V-24376-00	B - 13	5VS-25854-00	E - 9	5VX-27311-00	E - 10	5EA-81950-20	F - 9	437-83936-01	F - 7
5VX-21843-00	D - 7	3YJ-24481-00	D - 2	5SL-25855-00	E - 12	5VX-27315-00	E - 10	5EA-81952-00	F - 9	4XV-83945-00	F - 7
5VX-21871-00	D - 7	5JW-24486-00	D - 14	5VS-25855-00	E - 9	5VX-27321-00	E - 10	5VX-81960-00	F - 9	5LV-83951-00	F - 7
5VX-21873-00	D - 7	5SL-24491-00	D - 14	4BP-2585F-00	E - 12	5VX-27351-00	E - 10	5VX-819B0-00	F - 9	5VX-83969-00	F - 7
5VX-21875-00	D - 7	5JJ-24602-00	D - 14	3LN-2585G-00	E - 12	3YX-27413-00	E - 10	4TX-82100-02	F - 9	5VX-83975-00	F - 7
5VX-22110-00	D - 9	5VX-24711-00	E - 2	5VS-25867-00	E - 9	4XV-27424-00	C - 2	5SL-82113-00	F - 10	4HM-83980-00	E - 9
5JJ-22128-00	D - 9	5VX-24724-00	E - 2	5VX-25872-00	E - 9	5VX-27424-00	C - 14	5VX-82115-00	F - 9	5VX-84310-00	F - 5
4FN-22141-00	D - 9	4NK-24728-00	E - 2	5VX-25875-00	E - 9		E - 11	5VX-82116-00	F - 8	5VX-84310-10	F - 5
5VX-22151-00	D - 9	5VX-24730-00	E - 2	5SL-25876-00	E - 9	3VR-27431-01	E - 11	5VX-82122-00	D - 2	5VX-84312-00	F - 5
5EB-22184-00	D - 9	5VX-24773-00-P0	D - 4	5VX-2587A-00	E - 11	4BP-27434-01	C - 14	5VX-82123-00	F - 9	4SV-84314-00	F - 5
5VX-22210-00	D - 10	5VX-24773-00-P1	D - 4	5SL-25894-00	E - 12	5VX-27437-00	E - 11	122-82131-00	D - 5	8G9-84314-00	F - 5
34L-22216-00	D - 10	5VX-24773-00-P2	D - 4	5VX-25895-00	E - 12	3VR-27441-01	E - 11	3TJ-82131-00	D - 5	4SV-84347-00	F - 5
5VX-22836-00	D - 8	4BP-24780-00	E - 2	5VS-2589F-00	E - 9	5VX-27442-00	C - 14	1AE-82151-00	F - 9	4SV-84350-00	F - 5
5VX-23102-00	D - 12	5VX-2478E-00	E - 2	5VS-2589H-00	E - 9	5VX-27443-00	E - 11	5JJ-82151-20	F - 9	5VX-84359-00	F - 5
5VX-23103-00	D - 12	4BP-24792-00	E - 2	5SL-25914-00	E - 7	4BH-27451-01	E - 10	5JJ-82151-30	F - 9	5VX-84359-10	F - 5
5VX-23110-00	D - 12	4XV-25117-00	E - 3	5JW-25914-10	E - 4	4BH-27461-01	E - 11	5VX-82310-00	F - 8	5LV-84397-00	F - 5
4TX-23115-00	D - 12	5SL-25168-00-35	E - 3	5DH-25916-00	E - 7	5VX-28100-00	D - 5	5VX-82320-00	F - 8	5VX-84710-00	F - 6
5VX-23118-00	D - 12	4XV-25181-00	E - 3	3JD-25917-00	E - 7	31A-28217-00	D - 4	5VX-82370-00	F - 8	137-84714-60	F - 6
5VX-2311H-00	D - 12	4XV-25317-00	E - 5	5SL-25917-00	E - 7	5VX-2830C-00-P0	E - 13	5VX-82380-00	B - 13	5VX-84735-00	F - 6
4KM-23123-01	D - 13	5SL-25338-00-35	E - 5	4BP-25919-00	E - 4	5VX-2830C-00-P1	E - 13	5VX-82386-00	B - 14	4HC-84744-00	F - 6
4TX-23125-A0	D - 12	5VX-25364-00	E - 5	5SL-25919-00	E - 7	5VX-2830C-00-P2	E - 13	5SL-82511-08	F - 10	5VX-84745-00	F - 6
5VX-23126-00	D - 12	5SL-25366-00	E - 5	5VX-25921-50	E - 7	5VX-2830D-00-P0	E - 13	5VX-82530-00	F - 8	5SL-85110-00	D - 5
4TX-23135-A0	D - 12	5VX-25381-00	E - 6	8CR-25924-00	E - 7	5VX-2830D-00-P1	E - 13	3GB-82540-01	F - 8	3Y6-85130-02	D - 5
5VX-23136-00	D - 12	5SL-25383-00	E - 5	5SL-25926-00	E - 7	5VX-2830D-00-P2	E - 13	5VX-82541-00	F - 8	5VX-85720-00	F - 8
5VX-23141-00	D - 12	5VX-25388-01	E - 5	3YX-25929-00	E - 4	5VX-28356-00	E - 13	5VX-8255P-00	F - 10	8CC-85790-01	F - 8
4TX-23144-00	D - 12	2GH-25389-00	E - 5	4TT-25937-00	E - 4	5VX-2835G-00	E - 13	5VS-82566-60	F - 8	5FL-85885-01	B - 13
5VX-23145-00	D - 12	5MT-25398-00	E - 3	5VX-26111-00	E - 8	5VX-2835G-10	E - 13	5PS-82576-01	F - 9	5CA-85886-00	B - 12
4TX-23151-00	D - 12		E - 5	4YR-26240-01	E - 8	5VX-2836A-00	E - 14	5VX-82590-00	F - 9	5VX-8591A-00	F - 10
4TX-23156-00	D - 12	5MT-25398-10	E - 3	4YR-26241-01	E - 8	5VX-2836E-00	E - 14	1UA-82591-00	E - 9	4XY-88158-00	D - 4
5VX-23170-00	D - 12		E - 5	51J-26246-01	E - 8	5VX-2836K-00	E - 13		F - 7	5VS-W0041-00	E - 9
4TX-23173-00	D - 12	5MT-25398-20	E - 3	5VX-26280-00	E - 14	5VX-2836L-10	E - 13	5VX-82910-00	F - 7	5VX-W0042-50	E - 12
4TX-2331G-00	D - 12		E - 5	5VX-26290-00	E - 14	5VX-2836L-00	E - 14	3YX-82917-01	F - 7	5VX-W0045-00	E - 4
5VX-23340-00	D - 13	5VX-25446-00	E - 5	5VX-26311-00	E - 8	5VX-2836L-10	E - 14	5PW-83310-01	F - 3	5VX-W0046-00	E - 7
5VX-23377-00	D - 11	5VX-2580T-00	E - 4	5VX-26312-00	E - 8	5VX-28376-00	E - 13	1KH-83311-00	F - 3	4FU-W0047-00	E - 4
5VX-23389-00	D - 11	5VX-2580U-00	E - 4	5VS-26332-00	E - 9	5VX-28381-00	E - 13	5PW-83318-00	F - 3	5SL-W0047-00	E - 7
5VX-23415-00	D - 11	5VX-2580W-00	E - 7	5VX-26335-00	E - 8	5VX-28381-30	E - 13	5PW-83320-01	F - 3	1UY-W0048-00	E - 7
26H-23418-01	D - 11	5VX-2581K-00	E - 12	5VX-27111-02	E - 10	5VX-81410-00	E - 15	5VX-83330-00	F - 3	51L-W0048-00	E - 4
5VX-23435-00	D - 11	5VX-2581T-00	E - 4	5VX-27113-00	E - 10	5VX-81450-00	E - 15	5PW-8333A-00	F - 3	5KS-W0057-00	E - 4
4H7-23441-00-35	D - 11	5SL-25827-00	E - 7	371-27114-00	E - 2	5VX-81670-00	F - 8	5VX-83340-00	F - 3	5SL-W0057-00	E - 7
3FV-23462-00	D - 13	5SL-25827-10	E - 7	4GL-27114-00	E - 10	5VX-81673-00	F - 8	5PW-8334A-00	F - 3	2TV-W2470-00	E - 2
5VX-2411B-00	D - 14	5SL-25828-00	E - 7	5VX-27114-00	C - 14	4WP-81801-00	F - 2	3XV-83350-21	F - 10	5VS-W2587-00	E - 9

NUMERICAL INDEX

PART NO.	GRID NO.	PART NO.	GRID NO.	PART NO.	GRID NO.	PART NO.	GRID NO.	PART NO.	GRID NO.	PART NO.	GRID NO.
5VX-W8250-01	F - 10	90116-10485	E - 5	90201-06071	F - 6	90269-08066	D - 3	90445-11795	B - 12	90480-12006	C - 2
5VX-Y2410-30-01	D - 14	90119-06038	B - 8	90201-06380	F - 4	90338-06004	D - 11	90445-170K9	E - 10	90480-12072	D - 4
5VX-Y2410-30-02	D - 14	90119-06044	E - 12	90201-08083	E - 12	90338-06018	E - 2	90450-22017	B - 7	90480-12237	D - 3
5VX-Y2410-30-03	D - 14	90119-06062	D - 14	90201-08612	C - 2	90338-08174	B - 12		B - 9	90480-12314	B - 12
90105-06006	C - 4	90119-06096	D - 9	90201-086A3	C - 2	90338-21145	D - 2	90450-32001	B - 7	90480-13163	D - 7
90105-06027	B - 2	90119-06117	D - 7	90201-086P8	C - 3	90340-14132	B - 11		B - 9	90480-13398	D - 4
90105-06557	B - 8		D - 9	90201-08753	F - 8	90340-20090	B - 2	90450-35001	B - 7	90480-14229	E - 13
	D - 2	90119-10003	B - 2	90201-08784	C - 14	90340-32116	C - 6		B - 8	90480-14585	E - 13
	F - 8	90149-06019	E - 15	90201-087K3	C - 4	90383-14001	E - 11	90450-38040	B - 7	90480-15005	D - 14
90105-07004	B - 6	90149-06020	C - 4	90201-10020	D - 2	90387-06068	D - 14	90450-53002	B - 12	90480-15363	B - 8
90105-08386	F - 8	90149-06250	E - 15	90201-10021	E - 5	90387-06073	B - 12	90450-63003	B - 12	90480-18276	F - 6
90105-086A9	C - 4	90149-06308	E - 2	90201-10118	E - 9	90387-06075	D - 5	90464-13077	F - 9	90501-064L1	C - 13
90105-087A0	C - 4	90149-08003	E - 15		E - 12	90387-06078	D - 3	90464-13249	F - 9	90501-12743	E - 11
90105-10032	D - 2	90149-10006	D - 2	90201-10119	C - 9	90387-0614M	B - 8	90464-14002	D - 4	90501-225A9	C - 9
90105-10083	E - 10	90149-10012	D - 2	90201-101J1	D - 10	90387-061N6	C - 2	90464-14058	F - 9	90506-14003	C - 14
90105-10091	E - 10	90150-04041	D - 5	90201-12008	E - 15	90387-061W6	D - 14	90464-15157	D - 3	90506-20223	E - 12
90105-10323	D - 10	90150-05023	E - 13	90201-12013	C - 14	90387-06372	F - 9	90464-15192	F - 9	90506-23007	E - 10
90105-10638	E - 4	90151-06008	C - 11	90201-12021	E - 10		D - 9	90464-16005	D - 14	90506-26008	E - 10
90105-10N53	D - 2	90154-05042	F - 4	90201-12790	F - 8	90387-064J1	D - 4	90464-16006	D - 8	90506-50001	E - 10
90105-126A8	E - 15	90154-06061	D - 4	90201-14215	E - 12		D - 7		E - 14	90508-18016	C - 10
90109-06031	B - 10	90157-05079	E - 10	90201-15013	C - 10		D - 9		F - 9	90508-20572	E - 10
90109-06055	F - 10	90159-06002	C - 9	90201-154E8	C - 14	90387-065J6	D - 4	90464-16061	E - 2	90508-295B2	C - 14
90109-06060	D - 2	90164-05014	F - 5	90201-177G4	C - 14	90387-066H4	B - 8	90464-18002	D - 4	90560-06201	D - 7
90109-064G6	E - 4	90170-06228	C - 14	90201-186M4	D - 9	90387-082W9	C - 2	90464-18029	D - 5	91314-06020	C - 6
90109-065G3	C - 4	90170-08010	E - 12	90201-20278	C - 12	90387-09003	D - 4		F - 5	91314-06025	B - 6
90109-066F0	B - 2	90170-20008	C - 9	90201-220T0	D - 11	90387-1012B	D - 10	90464-20181	D - 7		C - 4
90109-08045	E - 7	90176-22081	D - 11	90201-231E1	D - 12	90387-127V3	C - 14	90464-54086	E - 13		C - 6
90109-080G5	F - 10	90179-05523	E - 13	90201-25015	E - 5	90387-22002	E - 3	90465-08045	C - 6	91314-06030	C - 6
90109-082A1	C - 2		F - 4	90201-255A6	C - 9	90387-2202V	C - 12	90465-10030	B - 11	91314-06060	B - 2
90109-083E2	E - 11	90179-06403	D - 4	90201-28014	E - 6	90387-25010	C - 9	90465-10035	C - 6	91314-08030	D - 11
90109-10011	E - 10	90179-07652	B - 3	90202-06170	E - 13	90387-2504A	C - 11	90465-13152	D - 5	91314-08045	D - 13
90109-10654	D - 10	90179-08410	C - 2	90202-24190	D - 11	90387-2513E	C - 11	90465-14011	C - 6	91314-10050	D - 2
90110-05014	D - 14	90179-18667	C - 12	90202-26142	D - 11	90387-253M6	C - 11	90467-08075	D - 7	91317-04025	F - 9
90110-05112	D - 14	90179-25033	D - 11	90206-12074	C - 14	90387-28001	E - 5	90467-090A1	E - 12	91317-05010	D - 14
90110-05201	E - 14	90183-05061	D - 4	90209-08295	E - 11	90387-2813C	C - 11	90467-10008	D - 14	91317-06016	F - 8
90110-06018	C - 13		F - 6	90209-21332	C - 11	90387-2813D	C - 11	90467-10041	B - 12	91317-06020	B - 2
90110-06020	B - 11	90183-05074	E - 13	90209-21351	C - 11	90401-10159	E - 9	90467-11090	B - 9		B - 12
90110-06022	C - 6	90183-06053	D - 2	90209-22352	C - 11		E - 12		B - 14	91317-06025	B - 11
90110-06041	B - 10		E - 14	90209-25342	C - 11	90401-20145	B - 11	90467-14015	B - 12	91317-08030	C - 2
90110-06079	D - 14	90183-060A1	D - 2	90209-25349	C - 11	90430-06014	B - 7	90467-15054	B - 12		D - 11
90110-06086	B - 7	90185-10002	D - 2	90209-25350	C - 11	90430-08119	B - 2	90467-17003	B - 15	91317-10025	D - 13
90110-06091	C - 4	90185-10009	E - 5	90215-20004	C - 9	90430-08143	C - 6	90467-17089	B - 14	91401-20012	E - 12
90110-06200	E - 13	90185-10037	E - 10	90215-21290	C - 12	90430-09002	B - 13		B - 15	91401-25015	E - 10
90110-08220	E - 11	90185-18104	D - 9	90240-08063	E - 11	90430-10148	F - 8	90467-17128	B - 15	91701-08040	E - 10
90110-10010	E - 10	90185-24165	E - 5	90240-08124	E - 12	90430-10171	D - 12	90467-200A0	B - 9	91808-17032	B - 10
90110-10N52	D - 12	90201-047A2	F - 9	90269-05049	E - 13	90445-08018	D - 7	90480-01558	D - 7	92014-06020	E - 12
90111-06016	B - 8	90201-05725	D - 5	90269-06010	F - 8	90445-10032	D - 14	90480-10332	C - 2	92014-08014	C - 6
90111-06019	C - 14	90201-06055	D - 3	90269-08001	D - 9	90445-10033	D - 14	90480-11005	F - 9	92014-08020	E - 12

NUMERICAL INDEX

PART NO.	GRID NO.	PART NO.	GRID NO.	PART NO.	GRID NO.	PART NO.	GRID NO.	PART NO.	GRID NO.	PART NO.	GRID NO.
92017-05025	F - 8	93315-42523	D - 9	95707-06500	E - 14	98507-06012	B - 13				
92017-06012	D - 5	93317-11020	C - 9		F - 9		C - 6				
92017-06014	D - 7	93317-11287	C - 15	95707-10500	E - 10	98704-03020	F - 7				
92017-06016	D - 6	93317-43580	E - 5	95807-06010	E - 9	98907-05008	D - 14				
92017-06020	D - 3	93399-99931	D - 11		F - 10	98907-05012	D - 4				
92017-08045	C - 3	93399-99932	D - 13	95807-06012	D - 11	98907-05014	F - 6				
92902-04100	E - 9	93420-61M07	E - 5	95807-06016	D - 7	98907-06012	D - 5				
92902-04600	E - 9	93440-10153	B - 2	95807-06020	F - 9	98907-06020	C - 2				
92907-05100	B - 13	93440-25084	C - 11	95807-06025	D - 2	99001-07600	C - 9				
92907-05600	B - 8	93440-28062	C - 11	95814-08035	E - 13	99009-10400	C - 9				
		93450-17129	B - 3	95814-08045	C - 2	99009-12400	B - 7				
92907-06100	B - 8	93501-04011	E - 11	95817-06045	C - 4	99009-17400	C - 14				
92907-06600	B - 8	93607-44190	B - 6	95817-06055	C - 4	99530-08012	B - 11				
		93608-17263	C - 6	95817-06065	C - 4		C - 6				
		93900-00030	E - 3	95817-06100	C - 4	99530-10014	C - 4				
			E - 5	95817-08014	C - 2	99530-10114	B - 2				
			E - 5	95817-08035	C - 2						
92907-08200	E - 6	94112-17066	E - 3	95817-08065	C - 4						
92907-08600	C - 9	94112-17067	E - 3	95824-06012	B - 9						
93101-12004	C - 15	94118-17041	E - 5	95824-06020	C - 14						
93101-12173	B - 7	94118-17053	E - 5	95824-06030	B - 8						
93102-15212	C - 9	94580-25080	B - 10	95827-06010	D - 7						
93102-35423	C - 12	94582-11118	E - 5	95827-06090	D - 14						
93106-28043	E - 3	94591-49120	B - 6	95827-08012	D - 5						
93106-40013	E - 5	94701-00403	B - 2	95827-08025	D - 4						
93109-17071	D - 10	95024-06020	B - 7	97007-05012	B - 8						
93210-04092	C - 4	95024-06025	D - 4	97007-06016	D - 5						
93210-06667	B - 10	95024-10020	B - 9	97007-06025	D - 9						
93210-09165	B - 10	95027-06008	F - 9	97017-06016	D - 11						
	C - 5	95027-06012	D - 3	97307-06012	B - 8						
93210-14003	B - 10		F - 8	97607-05255	F - 7						
93210-14579	C - 4	95027-06016	F - 8	97706-04012	F - 3						
93210-15566	B - 11	95027-06020	F - 7		F - 6						
93210-16325	C - 4	95027-06025	E - 9		D - 5						
93210-27194	C - 6	95027-06040	F - 2	97707-40012	D - 5						
93210-32172	C - 6	95027-08012	B - 2	97707-50012	D - 4						
93210-33133	B - 7	95304-06700	C - 14	97707-50016	E - 13						
93210-34504	D - 12	95307-08600	E - 6		F - 4						
93210-47675	B - 7	95607-04100	D - 5		F - 5						
93306-00106	B - 7	95607-05100	D - 5	97707-50025	B - 12						
93306-00304	C - 9	95607-05200	F - 8	97707-60016	F - 6						
93306-00420	E - 3	95607-06100	F - 7	98502-04012	E - 9						
93306-20464	C - 11	95607-10100	D - 10	98507-04010	F - 7						
93306-20531	E - 5	95607-10200	D - 2	98507-05010	B - 13						
93306-30525	C - 11		D - 10	98507-05016	B - 13						
93306-30546	C - 11	95617-06100	E - 9	98507-05020	F - 7						
93310-340N8	C - 9	95617-08625	B - 2	98507-05030	F - 7						
93315-31502	C - 9	95707-05500	D - 5	98507-05045	F - 7						
93315-31758	D - 10	95707-06500	E - 2	98507-06008	E - 11						