



PARTS CATALOGUE

PW50'08 (5PGG) EUROPE, SOUTH AFRICA

PW50
PARTS CATALOGUE
©2007 by Yamaha Motor Co., Ltd.
1st edition, May 2007
All rights reserved.
Any reprinting or unauthorized use
without the written permission of
Yamaha Motor Co., Ltd.
is expressly prohibited.
Printed in Japan.

A3

FOREWORD

This Parts Catalogue is related to the parts for the model(s) on the cover page. When you are ordering replacement parts, please refer to this Parts Catalogue and quote both part numbers and part names correctly.

1. Modifications or additions which have been made after the issue of the Parts Catalogue will be announced in the Parts News.

It is advisable that you make the necessary corrections to the Parts Catalogue according to the Parts News.

2. Abbreviations

The following abbreviations are used in this Parts Catalogue.

“UR” Use specified parts number.

“UN” Use as many as needed.

“AP” Alternate Parts

“LM” Locally Made (Parts need to be ordered locally)

“F#” Frame No. (Applicable machine No.)

“O/S” Over Size

3. The number of components for assembly

- Parts, which are to be supplied in an assembly, are listed with a dot (.) in front of the part name as shown below.
- The numeral appearing to the right of each component part indicates the quantity of parts for each assembly unit.

PART NO.	DESCRIPTION	Q'TY	REMARKS
2F5-83310-60	FRONT FLASHER LIGHT ASSY	2	
115-83311-60	.BULB (6V-18W)	1	

4. Applicable colours of graphics are represented in the “REMARKS” as shown below.

PART NO.	DESCRIPTION	Q'TY	REMARKS
2N4-24110-00-X5	FUEL TANK COMP.	2	MXR
3J1-24240-10	.GRAPHIC, FUEL TANK	1	FOR MXR

5. Note that the illustrations for reference in finding parts numbers are not to be used for assembling. When assembling, please use the applicable service manual.

6. The asterisk (*) before a reference number indicates modified items after the first edition.

FOREWORD

7. Applicable Serial No.

Engine Serial No.

Frame Serial No.

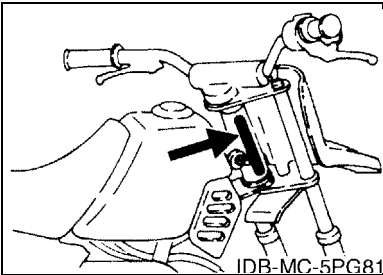
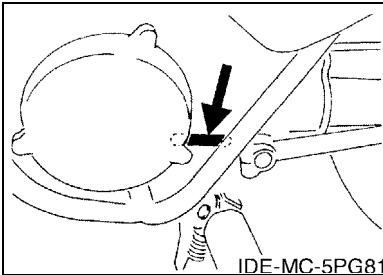

8. Applicable Colour Code (The (*) mark shows Model colour.)

Abbreviation	Colour Name	Colour Code
DPBSE(*)	DEEP PURPLISH BLUE SOLID E	0583
LGB	LOW GLOSS BLACK	0098
RW	RADICAL WHITE	00UJ
SL	SILVER	0035
YB	YAMAHA BLACK	0033

CONTENTS

ENGINE

CYLINDER	B2
CRANKSHAFT & PISTON	B3
OIL PUMP	B4
INTAKE	B5
CARBURETOR	B6
EXHAUST	B7
CRANKCASE	B8
STARTER	B9
CLUTCH	B10
TRANSMISSION	B11

CHASSIS

FRAME	B12
FRONT FENDER	B13
SIDE COVER	B14
OIL TANK	B15
REAR ARM & SUSPENSION	C2
DRIVE SHAFT	C3
FRONT FORK	C4
FUEL TANK	C5
SEAT	C6
FRONT WHEEL	C7
REAR WHEEL	C8
STEERING HANDLE & CABLE	C9
STAND & FOOTREST	C10
GENERATOR	C11
HANDLE SWITCH & LEVER	C12
ELECTRICAL 1	C13

INDEX

NUMERICAL INDEX	M1
-----------------------	----

FIG. 2 CRANKSHAFT & PISTON

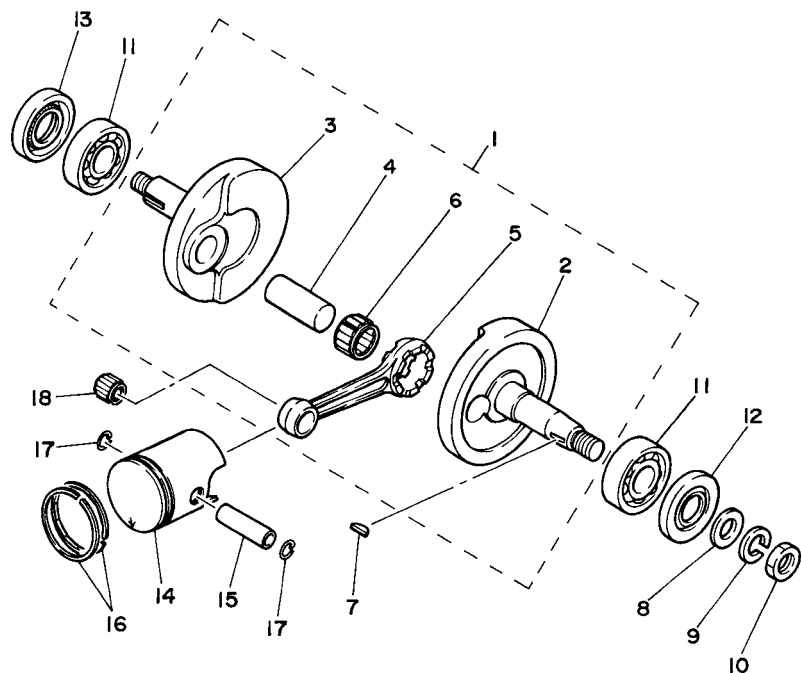

REF. NO.	PART NO.	DESCRIPTION	EUR	ZAF	JPN	REMARKS
1	3L5-11400-01	CRANKSHAFT ASSY	1	1	1	
2	3L5-11412-00	.CRANK 1	1	1	1	
3	3L5-11422-01	.CRANK 2	1	1	1	
4	54U-11681-00	.PIN, CRANK 1	1	1	1	
5	2E9-11651-00	.ROD, CONNECTING	1	1	1	
6	93310-416N7	.BEARING	1	1	1	
7	90280-03017	KEY, WOODRUFF	1	1	1	
8	92907-12600	WASHER, PLATE	1	1	1	
9	92907-12100	WASHER, SPRING	1	1	1	
10	95307-12700	NUT	1	1	1	
11	93306-20326	BEARING	2	2	2	
12	93102-17067	OIL SEAL	1	1	1	
13	93102-23174	OIL SEAL	1	1	1	
14	18U-11631-00-A0	PISTON (STD)	1	1	1	
	18U-11635-00	PISTON (0.25MM O/S)	1	1	1	AP
	18U-11636-00	PISTON (0.50MM O/S)	1	1	1	AP
15	3L5-11633-00	PIN, PISTON	1	1	1	
16	260-11610-04	PISTON RING SET (STD)	1	1	1	
	260-11610-14	PISTON RING SET (0.25MM O/S)	1	1	1	AP
	260-11610-24	PISTON RING SET (0.50MM O/S)	1	1	1	AP
17	93450-11021	CIRCLIP	2	2	2	
18	93310-21038	BEARING	1	1	1	



3PT110-0020

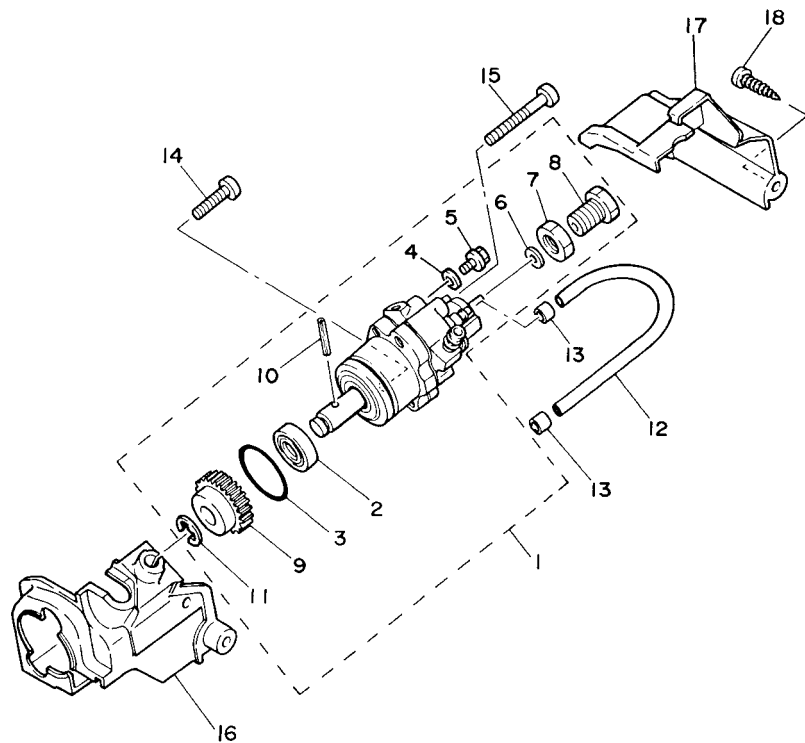

3PT110-0030

FIG. 3 OIL PUMP

REF. NO.	PART NO.	DESCRIPTION	EUR	ZAF	JPN	REMARKS
1	3L5-13101-01	OIL PUMP ASSY	1	1	1	
2	93101-10001	.OIL SEAL	1	1	1	
3	93210-26240	.O-RING	1	1	1	
4	90430-04004	.GASKET	1	1	1	
5	90149-04135	.SCREW	1	1	1	
6	384-13138-00	.PLATE, ADJUSTING	1	1	1	
7	90170-10105	.NUT	1	1	1	
8	90401-10029	.BOLT, UNION	1	1	1	
9	3L5-13124-00	.GEAR, WORM WHEEL (56T)	1	1	1	
10	91609-30014	.PIN, SPRING	1	1	1	
11	93430-07012	.CIRCLIP	1	1	1	
12	3L5-13161-00	PIPE, DELIVERY 1	1	1	1	
13	90468-02033	CLIP	2	2	2	
14	98507-05020	SCREW, PAN HEAD	1	1	1	
15	98507-05035	SCREW, PAN HEAD	1	1	1	
16	3L5-15416-00	COVER, OIL PUMP	1	1	1	
17	3L5-15426-00	COVER, OIL PUMP 2	1	1	1	
18	97707-50115	SCREW, TAPPING	1	1	1	

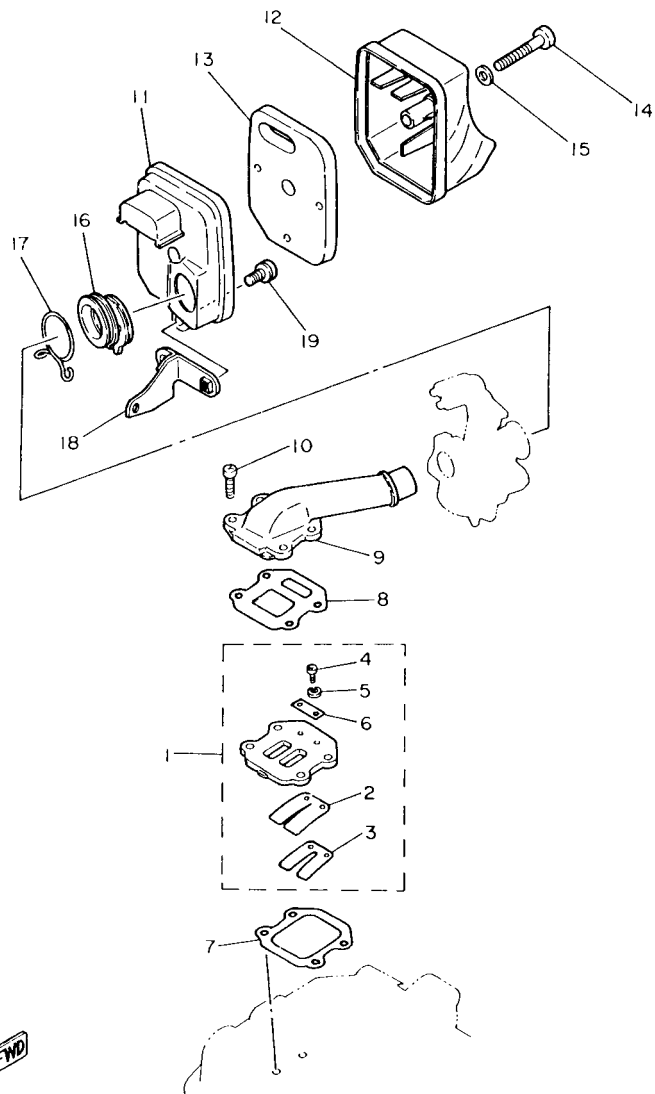

3PT110-1040

FIG. 4 INTAKE

REF. NO.	PART NO.	DESCRIPTION	EUR	ZAF	JPN	REMARKS
1	3L5-13610-00	REED VALVE ASSY	1	1	1	
2	3L5-13613-00	.REED, VALVE	1	1	1	
3	3L5-13616-00	.STOPPER, REED VALVE	1	1	1	
4	98507-03010	.SCREW, PAN HEAD	2	2	2	
5	92907-03100	.WASHER, SPRING	2	2	2	
6	3L5-13624-00	.PLATE, REED VALVE	1	1	1	
7	3HK-13621-00	GASKET, VALVE SEAT	1	1	1	
8	3L5-13622-10	GASKET, VALVE SEAT	1	1	1	
9	3L5-13555-00	MANIFOLD, INTAKE	1	1	1	
10	98507-06020	SCREW, PAN HEAD	4	4	4	
11	4X4-14411-00	CASE, AIR CLEANER 1	1	1	1	
12	4X4-14412-00	CAP, CLEANER CASE 1	1	1	1	
13	4X4-14451-00	ELEMENT, AIR CLEANER	1	1	1	
14	98507-06045	SCREW, PAN HEAD	1	1	1	
15	92907-06600	WASHER, PLATE	1	1	1	
16	4X4-14453-00	JOINT, AIR CLEANER 1	1	1	1	
17	90467-20023	CLIP	1	1	1	
18	4X4-14493-01	STAY 1	1	1	1	
19	90159-06013	SCREW, WITH WASHER	1	1	1	

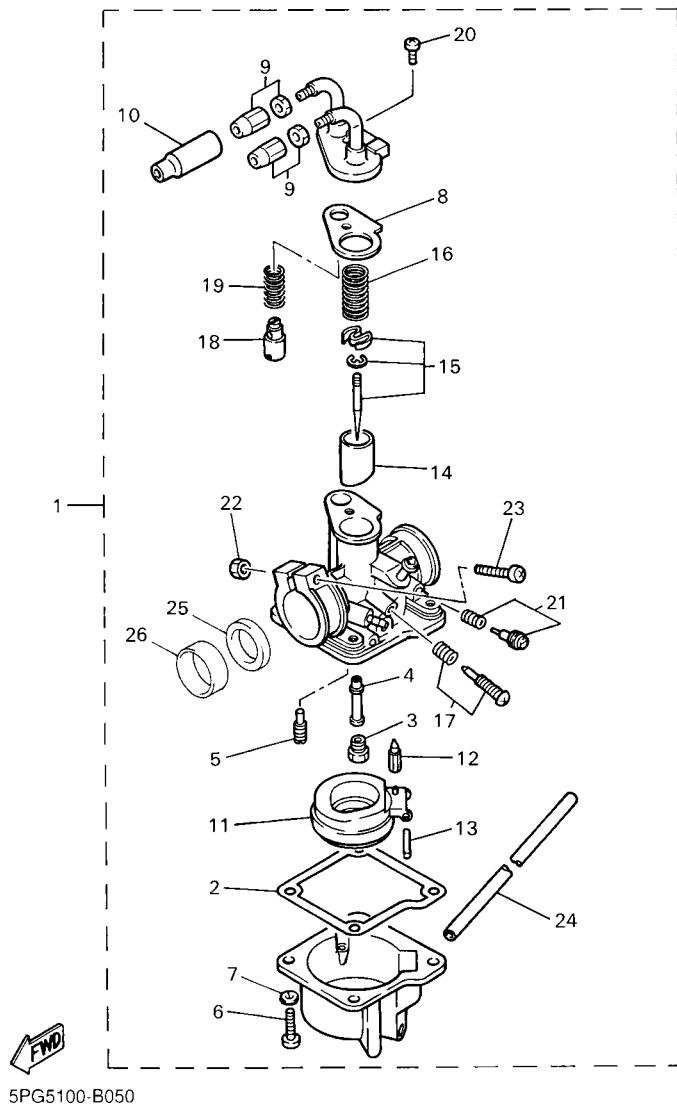
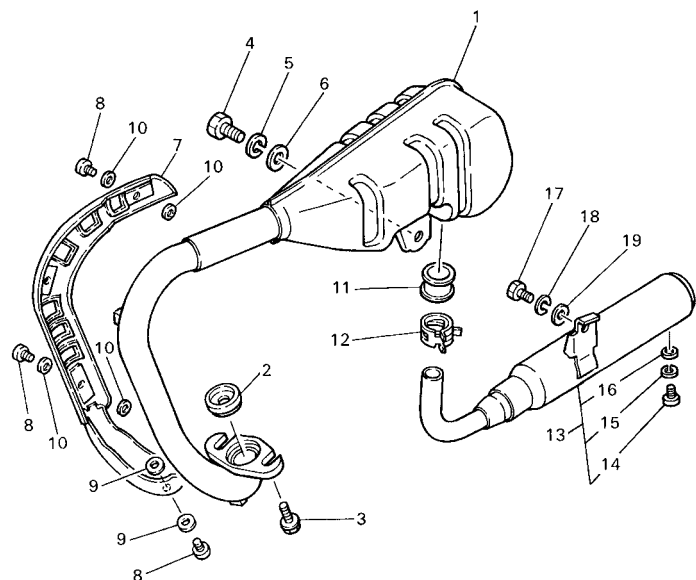

FIG. 5 CARBURETOR

REF. NO.	PART NO.	DESCRIPTION	EUR	ZAF	JPN	REMARKS
1	5PG-14101-10	CARBURETOR ASSY 1	1	1	1	
2	3L5-14184-00	.GASKET, FLOAT CHAMBER	1	1	1	
3	620-14231-14	.JET, MAIN (# 70)	1	1	1	
4	3L7-14141-12	.NOZZLE, MAIN	1	1	1	
5	3L5-14142-40	.JET, PILOT (# 40)	1	1	1	
6	98507-04014	.SCREW, PAN HEAD	4	4	4	
7	92907-04100	.WASHER, SPRING	4	4	4	
8	3L5-14198-00	.GASKET	1	1	1	
9	17L-14106-00	.CABLE ADJUST SCREW SET	2	2	2	
10	1R0-14169-00	.CAP	1	1	1	
11	3L6-14185-01	.FLOAT	1	1	1	
12	3L5-14190-01	.NEEDLE VALVE ASSY	1	1	1	
13	603-14186-00	.PIN, FLOAT	1	1	1	
14	3L5-14112-40	.VALVE, THROTTLE 1	1	1	1	
15	5PG-1490J-00	.NEEDLE SET	1	1	1	
16	174-14131-01	.SPRING, THROTTLE VALVE	1	1	1	
17	36R-14103-00	.THROTTLE SCREW SET	1	1	1	
18	127-14171-00	.PLUNGER, STARTER	1	1	1	
19	127-14135-00	.SPRING, PLUNGER	1	1	1	
20	98607-05112	.SCREW, OVAL HEAD	1	1	1	
21	36R-14104-00	.AIR SCREW SET	2	2	2	
22	98807-05100	.NUT	1	1	1	
23	98507-05030	.SCREW, PAN HEAD	1	1	1	
24	214-14197-00	.PIPE	1	1	1	
25	1M3-14997-00	.SEAL	1	1	1	
26	1V3-14271-00	.INSULATOR	1	1	1	

FIG. 6 EXHAUST



3PT100-5060

REF. NO.	PART NO.	DESCRIPTION	EUR	ZAF	JPN	REMARKS
1	4X4-14610-01	EXHAUST PIPE ASSY 1	1	1	1	
2	4X4-14623-10	GASKET, EXHAUST PIPE	1	1	1	
3	90153-06011	SCREW, HEXAGON	2	2	2	
4	97007-08020	BOLT	1	1	1	
5	92907-08100	WASHER, SPRING	1	1	1	
6	92907-08600	WASHER, PLATE	1	1	1	
7	4X4-14708-00	PROTECTOR ASSY	1	1	1	
8	90157-05003	SCREW, PAN HEAD	4	4	4	
9	90202-04214	WASHER, PLATE	2	2	2	
10	3RV-14766-00	WASHER, PROTECTOR	6	6	6	
11	4X4-14714-00	GASKET, MUFFLER	1	1	1	
12	90467-22048	CLIP	1	1	1	
13	4X4-14750-00	SILENCER ASSY	1	1	1	
14	98507-06008	.SCREW, PAN HEAD	1	1	1	
15	92907-06100	.WASHER, SPRING	1	1	1	
16	92907-06600	.WASHER, PLATE	1	1	1	
17	97007-06016	BOLT	1	1	1	
18	92907-06100	WASHER, SPRING	1	1	1	
19	92907-06600	WASHER, PLATE	1	1	1	

FIG. 7 CRANKCASE

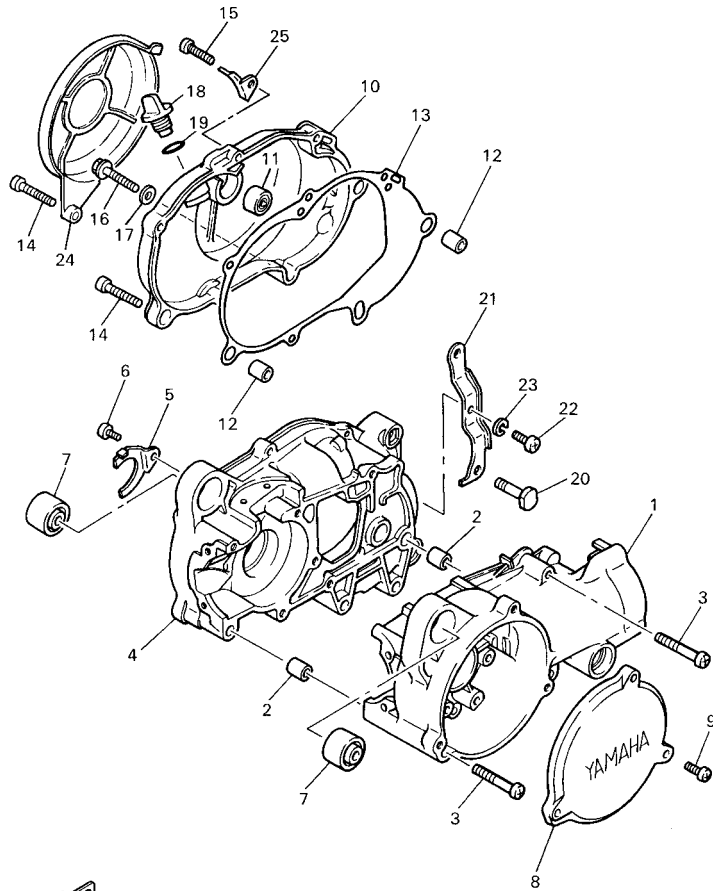

3PT100-5070

REF. NO.	PART NO.	DESCRIPTION	EUR	ZAF	JPN	REMARKS
1	4X4-15111-00	CRANKCASE 1	1	1	1	
2	99530-12016	PIN, DOWEL	2	2	2	
3	98507-06045	SCREW, PAN HEAD	8	8	8	
4	4J2-15121-01	CRANKCASE 2	1	1	1	
5	3L5-15128-00	HOLDER	1	1	1	
6	98507-06012	SCREW, PAN HEAD	1	1	1	
7	2E9-15316-00	DAMPER, ENGINE MOUNT 1	2	2	2	
8	4J2-15415-00	COVER, GENERATOR	1	1	1	
9	98507-05014	SCREW, PAN HEAD	3	3	3	
10	4X4-15421-02	COVER, CRANKCASE 2	1	1	1	
11	3L5-17112-01	BUSH 1	1	1	1	
12	99530-12016	PIN, DOWEL	2	2	2	
13	3L5-15451-11	GASKET, CRANKCASE COVER 1	1	1	1	
14	98507-06035	SCREW, PAN HEAD	3	3	3	
15	98507-06025	SCREW, PAN HEAD	3	3	3	
16	90105-08103	BOLT, FLANGE	1	1	1	
17	90430-08119	GASKET	1	1	1	
18	4J2-15363-00	PLUG, OIL	1	1	1	
19	93210-14104	O-RING	1	1	1	
20	90109-08582	BOLT	2	2	2	
21	4J2-15113-00	PLATE	1	1	1	
22	98507-06012	SCREW, PAN HEAD	1	1	1	
23	92907-06100	WASHER, SPRING	1	1	1	
24	4X4-15491-00	PROTECTOR	1	1	1	
25	4X4-15484-00	CLAMP 2	1	1	1	

FIG. 9 CLUTCH

REF. NO.	PART NO.	DESCRIPTION	EUR	ZAF	JPN	REMARKS
1	3L5-16111-00	GEAR, PRIMARY DRIVE (33T)	1	1	1	
2	3L5-16115-00	ABSORBER 1	1	1	1	
3	3L5-16125-00	ABSORBER 2	1	1	1	
4	3L5-16114-00	PLATE, THRUST 2	1	1	1	
5	3L5-16181-01	SPACER 1	1	1	1	
6	90387-16730	COLLAR	1	1	1	
7	90282-05034	KEY, STRAIGHT	1	1	1	
8	90208-10012	WASHER, CONICAL SPRING	1	1	1	
9	90170-10206	NUT	1	1	1	
10	99009-16400	CIRCLIP	1	1	1	
11	90201-16383	WASHER, PLATE	1	1	1	
12	3L5-16620-03	CLUTCH CARRIER ASSY	1	1	1	
13	3L5-16628-02	.WASHER	2	2	2	
14	2T4-16629-00	.DAMPER, CLUTCH WEIGHT	2	2	2	
15	3L5-16627-02	.SPRING, CLUTCH WEIGHT 2	2	2	2	
16	3L5-16633-02	.SHAFT, CLUTCH WEIGHT	4	4	4	
17	3L5-16611-02	CLUTCH HOUSING COMP.	1	1	1	
18	99009-16400	CIRCLIP	1	1	1	

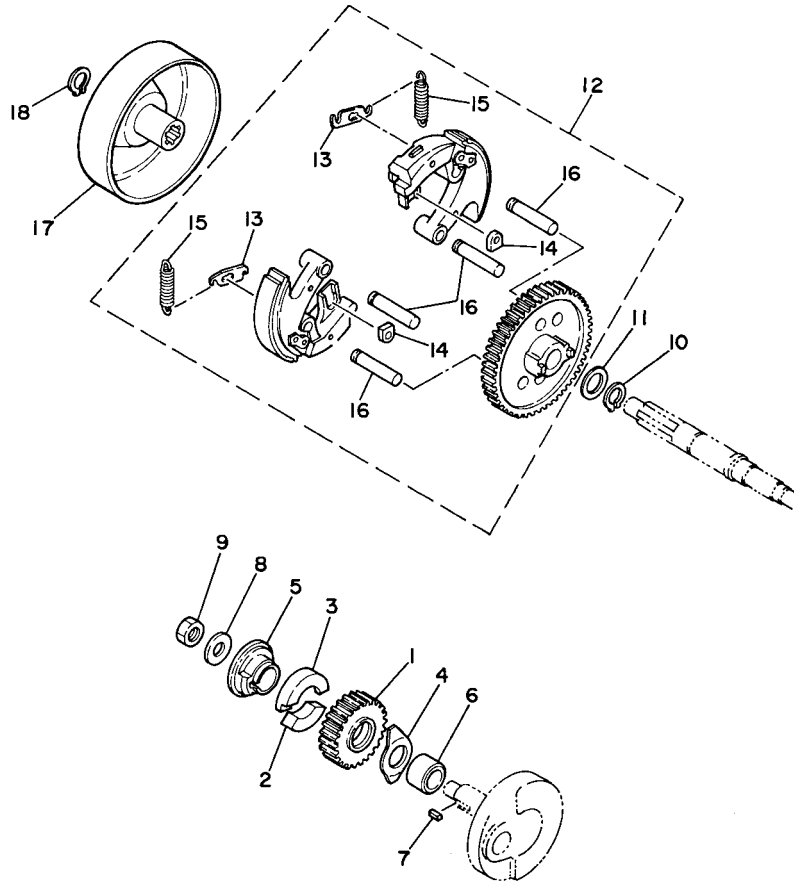

3PT110-0090

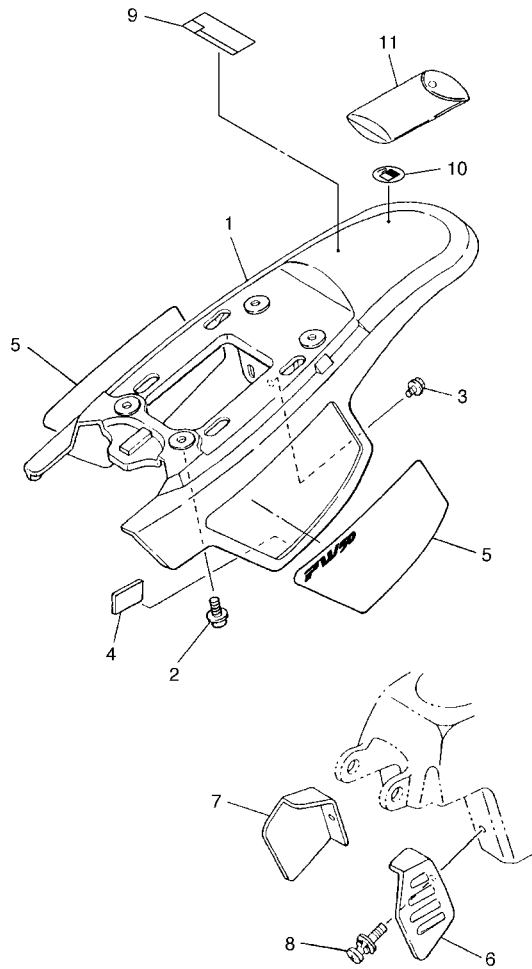

FIG. 13 SIDE COVER

REF. NO.	PART NO.	DESCRIPTION	EUR	ZAF	JPN	REMARKS
1	3PT-21711-10	COVER, SIDE 1	1	1	1	
2	90159-06060	SCREW, WITH WASHER	4	4	4	
3	90119-06060	BOLT, WITH WASHER	2	2	2	
4	4X4-24181-00	DAMPER, LOCATING 1	2	2	2	
5	3PT-2173L-A0	GRAPHIC SET 1	1	1	1	
6	3PT-21731-60	COVER, SIDE 3	1	1	1	
7	3PT-21741-60	COVER, SIDE 4	1	1	1	
8	90159-06058	SCREW, WITH WASHER	2	2	2	
9	5PA-21568-00	LABEL, WARNING	1	1		
10	N/A					
11	4X4-28100-00	TOOL KIT	1	1	1	



5PGC300-E130

FIG. 15 REAR ARM & SUSPENSION

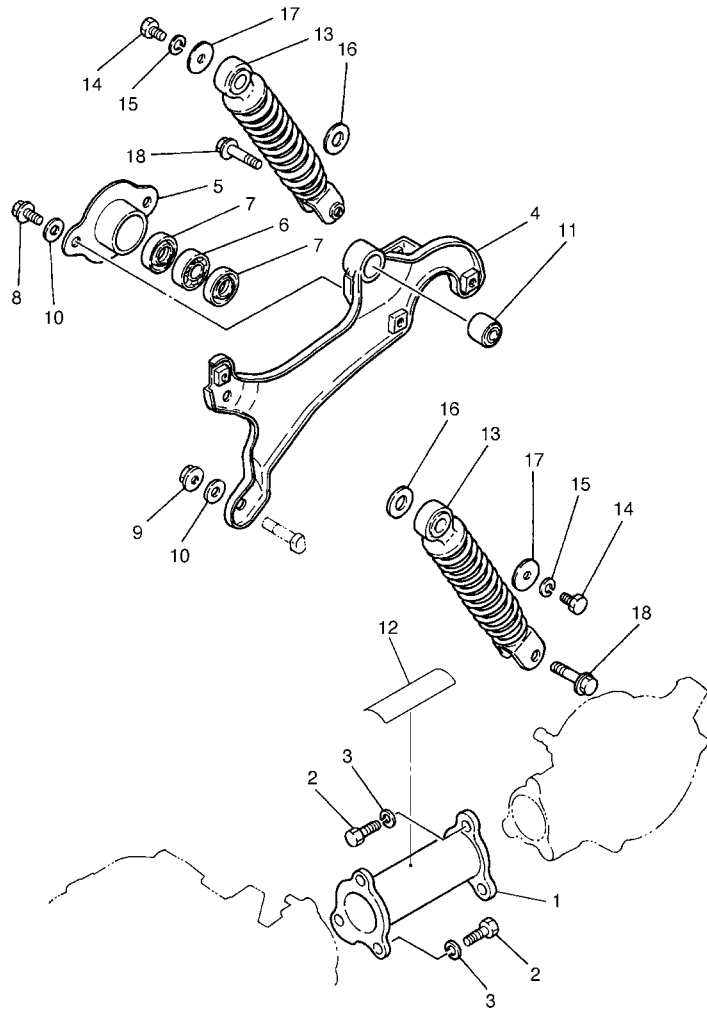

5PGC300-E150

REF. NO.	PART NO.	DESCRIPTION	EUR	ZAF	JPN	REMARKS
1	3L7-22110-00-98	REAR ARM COMP.	1	1	1	LGB
2	90101-08461	BOLT	6	6	6	
3	92907-08100	WASHER, SPRING	6	6	6	
4	4X4-22110-10	REAR ARM COMP.	1	1	1	
5	4J2-22174-01	END 1	1	1	1	
6	93306-20117	BEARING	1	1	1	
7	93106-24018	OIL SEAL	2	2	2	
8	90105-08066	BOLT, FLANGE	2	2	2	
9	95707-08500	NUT, FLANGE	2	2	2	
10	90201-08326	WASHER, PLATE	4	4	4	
11	164-22216-00	BUSH, REAR SHOCK ABSORBER	1	1	1	
12	3RV-21668-A0	LABEL, TIRE	1	1		
13	3PT-22210-10	SHOCK ABSORBER ASSY, REAR	2	2	2	
14	97027-06016	BOLT	2	2	2	
15	92907-06100	WASHER, SPRING	2	2	2	
16	90201-126A7	WASHER, PLATE	2	2	2	
17	90201-067A0	WASHER, PLATE	2	2	2	
18	90105-08121	BOLT, FLANGE	2	2	2	

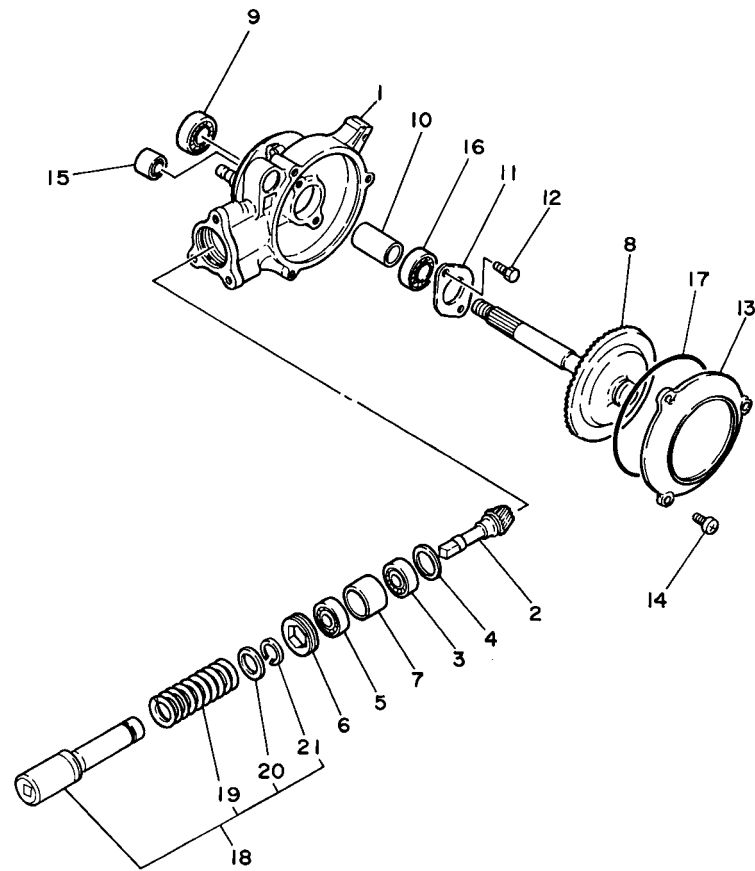

3PT110-0160

FIG. 16 DRIVE SHAFT

REF. NO.	PART NO.	DESCRIPTION	EUR	ZAF	JPN	REMARKS
1	4J2-46151-01	HOUSING, DRIVE SHAFT	1	1	1	
2	59M-46121-00	GEAR, DRIVE PINION	1	1	1	
3	93306-20111	BEARING	1	1	1	
4	3L5-46127-00	SHIM, DRIVE PINION	1	1	1	
5	93306-20111	BEARING	1	1	1	
6	90149-35133	SCREW	1	1	1	
7	90560-25185	SPACER	1	1	1	
8	4J2-46110-01	RING GEAR COMP.	1	1	1	
9	93306-20203	BEARING	1	1	1	
10	90560-15315	SPACER	1	1	1	
11	3L5-46114-00	PLATE, COVER	1	1	1	
12	97017-06016	BOLT	2	2	2	
13	4J2-46154-02	COVER, HOUSING	1	1	1	
14	95027-06016	BOLT, FLANGE	3	3	3	
15	164-22216-00	BUSH, REAR SHOCK ABSORBER	1	1	1	
16	93306-20205	BEARING	1	1	1	KOYO
17	93211-066A9	O-RING	1	1	1	
18	3L7-46171-00	SHAFT DRIVE ASSY	1	1	1	
19	90501-60556	.SPRING, COMPRESSION	1	1	1	
20	15L-18473-00	.RETAINER, SPRING	1	1	1	
21	93440-17138	.CIRCLIP	1	1	1	

FIG. 17 FRONT FORK

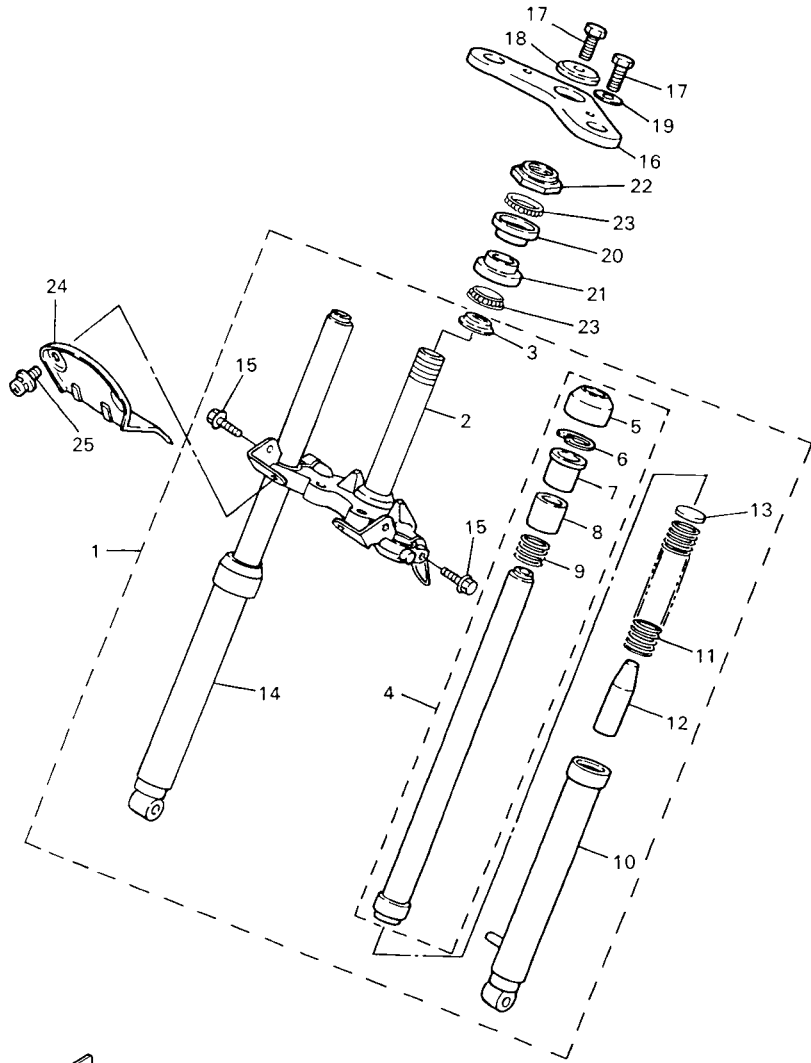

5PG2300-1170

REF. NO.	PART NO.	DESCRIPTION	EUR	ZAF	JPN	REMARKS
1	3PT-23100-01-35	FRONT FORK ASSY	1	1	1	SL
2	3PT-23340-00	.UNDER BRACKET COMP.	1	1	1	
3	3YJ-23414-00	.RACE, BALL 4	1	1	1	
4	3PT-23110-00	.INNER TUBE COMP.1	1	1	1	
5	2E9-23144-01	..SEAL, DUST	1	1	1	
6	93450-30057	..CIRCLIP	1	1	1	
7	54V-23125-02	..METAL, SLIDE 1	1	1	1	
8	2E9-23113-01	..COLLAR	1	1	1	
9	36R-23151-00	..SPRING, REBOUND	1	1	1	
10	4X4-23106-00-35	.OUTER TUBE COMP. (L.H)	1	1	1	SL
11	4X4-23141-00	.SPRING, FRONT FORK	1	1	1	
12	3L6-23195-00	.RUBBER	1	1	1	
13	2E9-23143-00	.SEAT, SPRING LOWER	1	1	1	
14	3PT-23103-00-35	.FRONT FORK ASSY (R.H)	1	1	1	SL
15	95027-08030	.BOLT, FLANGE	2	2	2	
16	4X4-23435-00	CROWN, HANDLE	1	1	1	
17	90105-10006	BOLT, FLANGE	3	3	3	
18	90209-10160	WASHER	1	1	1	
19	90201-105H3	WASHER, PLATE	2	2	2	
20	2E9-23412-00	RACE, BALL 2	1	1	1	
21	2E9-23413-01	RACE, BALL 3	1	1	1	
22	3PT-23411-00	RACE, BALL 1	1	1	1	
23	93505-32042	BALL	2	2	2	
24	4X4-21543-00	PLATE 1	1	1	1	
25	90159-06060	SCREW, WITH WASHER	2	2	2	

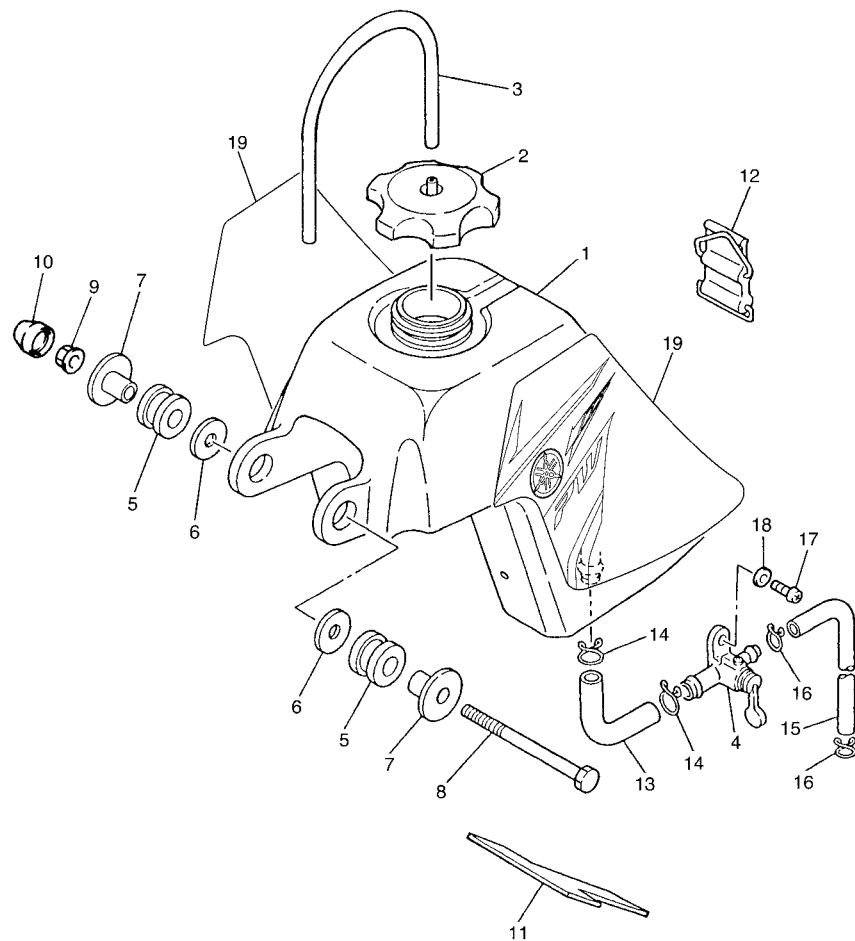

FIG. 18 FUEL TANK

REF. NO.	PART NO.	DESCRIPTION	EUR	ZAF	JPN	REMARKS
1	5PG-24110-10	FUEL TANK COMP.	1	1	1	
2	2FG-24610-00	CAP ASSY	1	1	1	
3	90445-09251	HOSE (L350)	1	1	1	
4	4X4-24500-00	FUEL COCK ASSY 1	1	1	1	
5	90480-18290	GROMMET	2	2	2	
6	90201-06747	WASHER, PLATE	2	2	2	
7	90387-077F4	COLLAR	2	2	2	
8	97007-06090	BOLT	1	1	1	
9	95707-06500	NUT, FLANGE	1	1	1	
10	5PG-2467E-00	CAP	1	1	1	
11	3R0-24181-00	DAMPER, LOCATING 1	1	1	1	
12	59V-24173-00	BAND, TANK FITTING 1	1	1	1	
13	5PG-24311-10	PIPE, FUEL 1	1	1	1	
14	90467-12052	CLIP	2	2	2	
15	90445-095J0	HOSE (L130)	1	1	1	
16	90467-08003	CLIP	2	2	2	
17	98507-06010	SCREW, PAN HEAD	1	1	1	
18	92907-06600	WASHER, PLATE	1	1	1	
19	5PG-24240-00	GRAPHIC SET	1	1	1	



5PGG300-G180

FIG. 21 REAR WHEEL

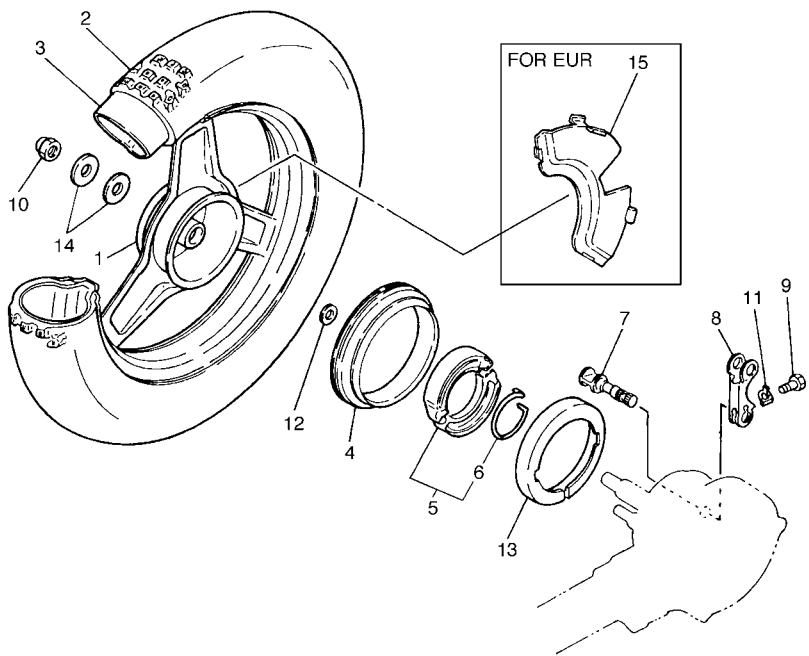

REF. NO.	PART NO.	DESCRIPTION	EUR	ZAF	JPN	REMARKS
1	5M0-25390-00-UJ	REAR WHEEL COMP.	1	1	1	RW
2	L.M.	TIRE (2.50-10)		1		
3	94225-10270	TUBE (2.50/2.75-10)	1	1	1	INOUE
4	2T4-25185-00	RING 1	1	1	1	
5	3PT-W253A-10	BRAKE SHOE KIT	1	1	1	
6	2E9-25133-00	.SPRING, RETURN	1	1	1	
7	3L5-25351-00	CAMSHAFT	1	1	1	
8	3L5-25355-00	LEVER, CAMSHAFT	1	1	1	
9	90101-05396	BOLT	1	1	1	
10	90185-12046	NUT, SELF-LOCKING	1	1	1	
11	2E9-25412-00	WASHER	1	1	1	
12	90201-15700	WASHER, PLATE	1	1	1	
13	4X4-25336-00	RING 2	1	1	1	
14	90387-125A5	COLLAR	2	2	2	
15	N/A					



5PG8300-C210

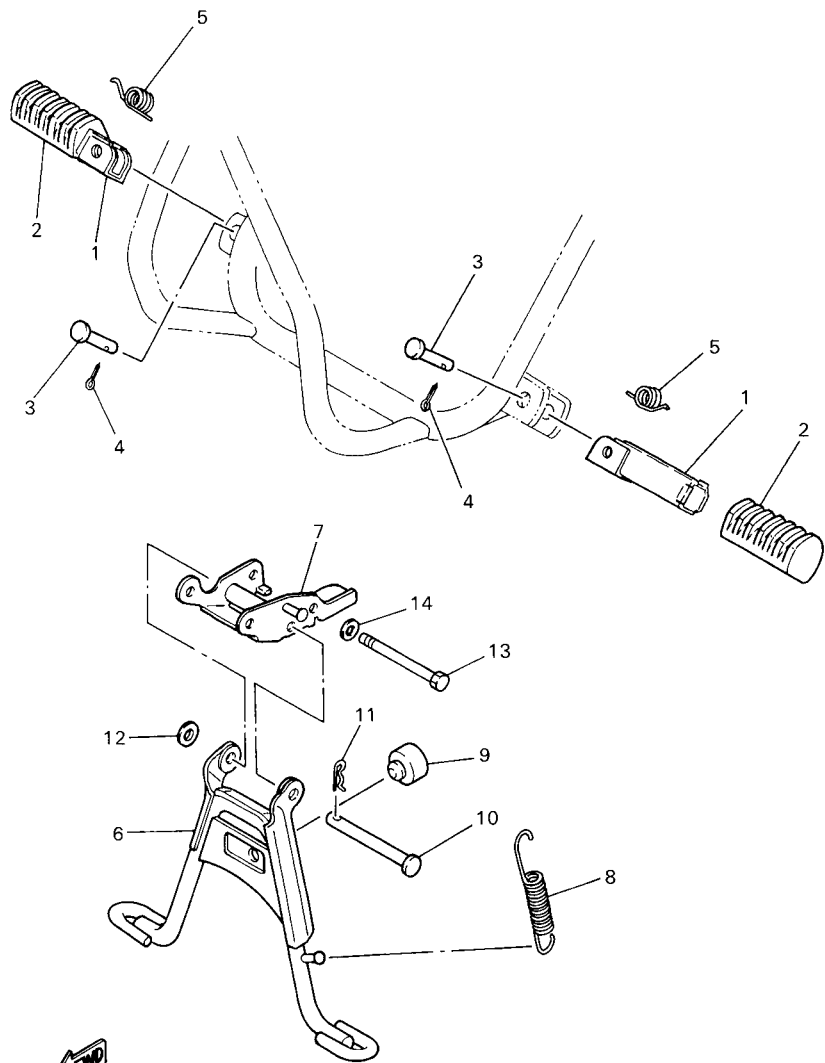

5PG5100-B230

FIG. 23 STAND & FOOTREST

REF. NO.	PART NO.	DESCRIPTION	EUR	ZAF	JPN	REMARKS
1	214-27421-00	FOOTREST 2	2	2	2	
2	4X4-27413-00	COVER, FOOTREST	2	2	2	
3	90240-08084	PIN, CLEVIS	2	2	2	
4	91401-25015	PIN, COTTER	2	2	2	
5	90508-20023	SPRING, TORSION	2	2	2	
6	4X4-27111-00-33	STAND, MAIN	1	1	1	YB
7	3L5-27151-02	BRACKET, MAIN STAND	1	1	1	
8	90506-29052	SPRING, TENSION	1	1	1	
9	4X4-27114-00	STOPPER, MAIN STAND	1	1	1	
10	91701-08078	PIN, CLEVIS	1	1	1	
11	90468-12006	CLIP	1	1	1	
12	92907-08600	WASHER, PLATE	1	1	1	
13	91317-06070	BOLT	2	2	2	
14	90201-06045	WASHER, PLATE	2	2	2	

FIG. 24 GENERATOR

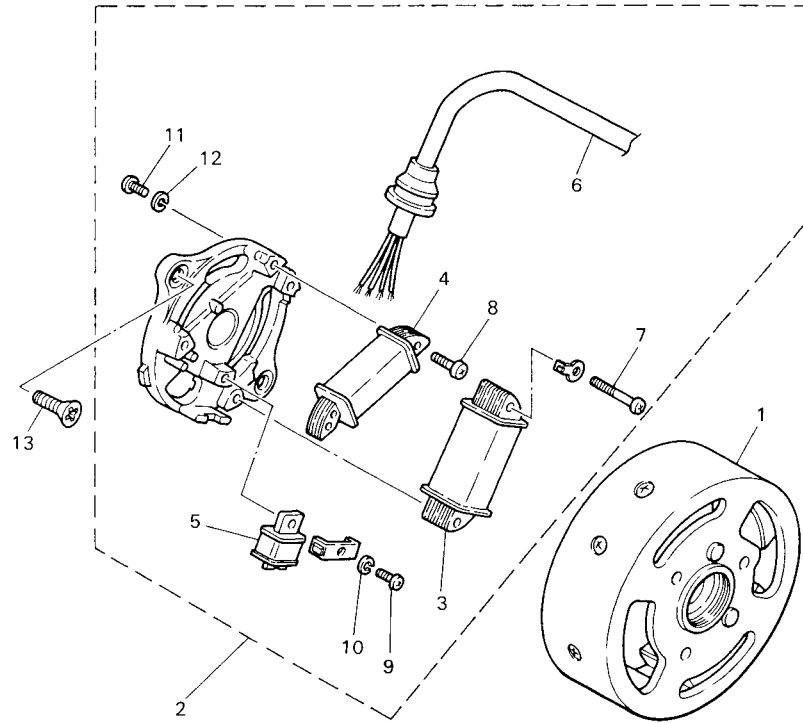

REF. NO.	PART NO.	DESCRIPTION	EUR	ZAF	JPN	REMARKS
1	3L6-85550-M1	ROTOR ASSY	1	1	1	
2	3PT-85560-00	BASE ASSY	1	1	1	
3	4X4-81313-M0	.COIL, LIGHTING 1	1	1	1	
4	4Y4-85520-M0	.COIL, CHARGE	1	1	1	
5	3L5-85580-M0	.COIL, PULSER	1	1	1	
6	3PT-8131X-00	.CORD ASSY	1	1	1	
7	98517-04025	.SCREW, PAN HEAD	2	2	2	
8	98517-04012	.SCREW, PAN HEAD	2	2	2	
9	98507-04010	.SCREW, PAN HEAD	1	1	1	
10	92907-04100	.WASHER, SPRING	1	1	1	
11	98507-04006	.SCREW, PAN HEAD	1	1	1	
12	92907-04100	.WASHER, SPRING	1	1	1	
13	98707-06016	SCREW, FLAT HEAD	2	2	2	



5PG1100-1240

FIG. 25 HANDLE SWITCH & LEVER

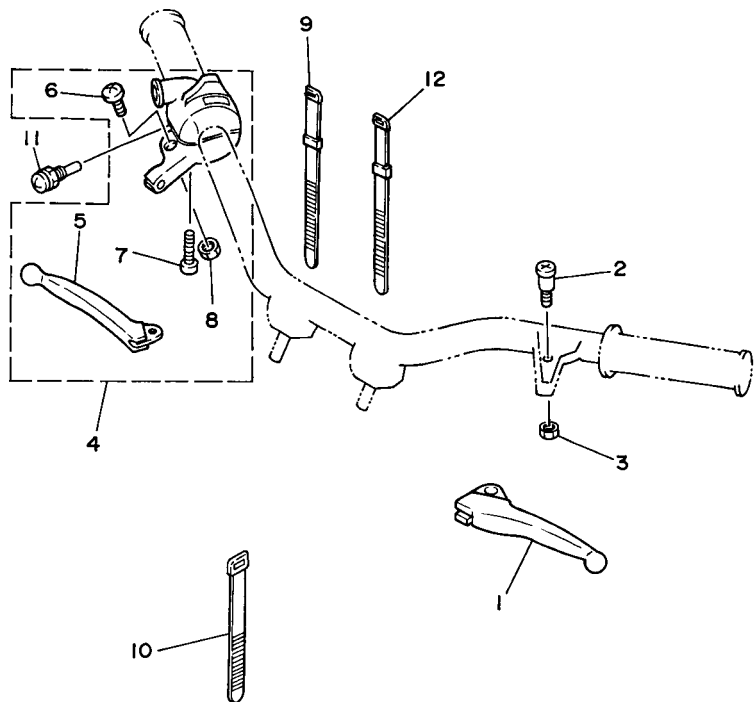

3PT110-0250

REF. NO.	PART NO.	DESCRIPTION	EUR	ZAF	JPN	REMARKS
1	2T4-83912-02	LEVER 1	1	1	1	
2	90149-05162	SCREW	1	1	1	
3	95607-05100	NUT, U	1	1	1	
4	5PG-82920-00	LEVER HOLDER ASSY (RIGHT)	1	1	1	
5	2T4-83922-02	.LEVER 2	1	1	1	
6	90149-05119	.SCREW	1	1	1	
7	98507-05025	.SCREW, PAN HEAD	2	2	2	
8	95607-05100	.NUT, U	1	1	1	
9	437-83936-01	BAND, SWITCH CORD	1	1	1	
10	3TB-83936-00	BAND, SWITCH CORD	1	1	1	
11	4X4-26257-00	STOPPER	1	1	1	
12	90465-10098	CLAMP	1	1	1	

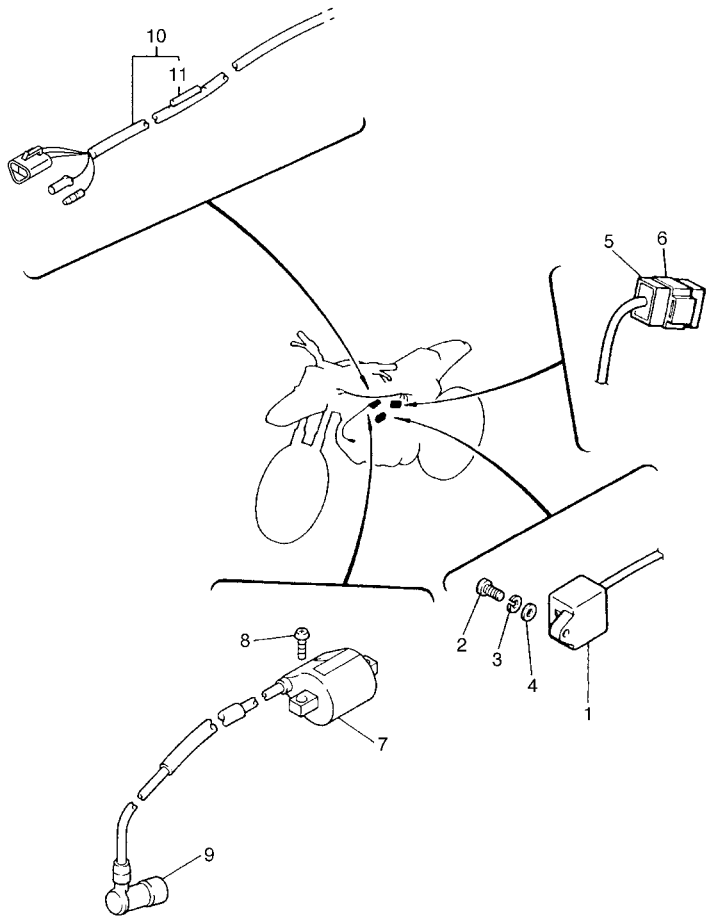

5PGC300-E260

FIG. 26 ELECTRICAL 1

REF. NO.	PART NO.	DESCRIPTION	EUR	ZAF	JPN	REMARKS
1	3PT-85540-00	C.D.I. UNIT ASSY	1	1	1	
2	98507-06016	SCREW, PAN HEAD	1	1	1	
3	92907-06100	WASHER, SPRING	1	1	1	
4	92907-06600	WASHER, PLATE	1	1	1	
5	5PG-85590-00	CONTROL UNIT ASSY	1	1	1	
6	4J2-85546-00	BAND	1	1	1	
7	4JP-82310-00	IGNITION COIL ASSY	1	1	1	
8	97007-06016	BOLT	2	2	2	
9	166-82370-20	PLUG CAP ASSY	1	1	1	
10	5PG-82590-00	WIRE HARNESS ASSY	1	1	1	
11	3K7-81980-00	.DIODE ASSY	1	1	1	

NUMERICAL INDEX

PART NO.	GRID NO.	PART NO.	GRID NO.	PART NO.	GRID NO.	PART NO.	GRID NO.	PART NO.	GRID NO.	PART NO.	GRID NO.
4J2-11111-00	B - 2	4X4-14412-00	B - 5	3L5-17537-00	B - 11	59V-24173-00	C - 5	4J2-46110-01	C - 3	90159-06060	B - 13
517-11181-01	B - 2	4X4-14451-00	B - 5	15L-17552-00	B - 11	3R0-24181-00	C - 5	3L5-46114-00	C - 3		B - 14
4J2-11311-00	B - 2	4X4-14453-00	B - 5	15L-18473-00	C - 3	4X4-24181-00	B - 14	59M-46121-00	C - 3		C - 4
3PT-11351-00	B - 2	4X4-14493-01	B - 5	36E-21110-01-33	B - 12	5PG-24240-00	C - 5	3L5-46127-00	C - 3	90170-10105	B - 4
3L5-11400-01	B - 3	4X4-14610-01	B - 7	5PA-2118K-20	B - 13	5PG-24311-10	C - 5	4J2-46151-01	C - 3	90170-10206	B - 10
3L5-11412-00	B - 3	4X4-14623-10	B - 7	3PT-21511-20	B - 13	4X4-24500-00	C - 5	4J2-46154-02	C - 3	90179-06411	C - 9
3L5-11422-01	B - 3	4X4-14708-00	B - 7	36E-21513-00	B - 13	2FG-24610-00	C - 5	3L7-46171-00	C - 3	90185-10091	C - 7
260-11610-04	B - 3	4X4-14714-00	B - 7	4X4-21543-00	C - 4	5PG-2467E-00	C - 5	4X4-81313-M0	C - 11	90185-12046	C - 8
260-11610-14	B - 3	4X4-14750-00	B - 7	5PA-21568-00	B - 14	5PG-24710-00	C - 6	3PT-8131X-00	C - 11	90201-06045	C - 10
260-11610-24	B - 3	3RV-14766-00	B - 7	3PT-21569-80	B - 13	5PG-24711-00	C - 6	3K7-81980-00	C - 13	90201-06747	C - 5
18U-11631-00-A0	B - 3	5PG-1490J-00	B - 6	4X4-21629-00	B - 15	2E9-25116-00	C - 7	4JP-82310-00	C - 13	90201-067A0	C - 2
3L5-11633-00	B - 3	1M3-14997-00	B - 6	3XJ-21668-10	C - 2	2T4-25121-00-98	C - 7	166-82370-20	C - 13	90201-08326	C - 2
18U-11635-00	B - 3	4X4-15111-00	B - 8	3RV-21668-A0	C - 2	2E9-25133-00	C - 7	5PG-82590-00	C - 13	90201-105H3	C - 4
18U-11636-00	B - 3	4J2-15113-00	B - 8	3PT-21711-10	B - 14			5PG-82920-00	C - 12	90201-126A7	C - 2
2E9-11651-00	B - 3	4J2-15121-01	B - 8	4X4-2172K-00	B - 15	2E9-25151-01	C - 7	2T4-83912-02	C - 12	90201-15700	C - 8
54U-11681-00	B - 3	3L5-15128-00	B - 8	3PT-21731-60	B - 14	2T4-25155-00	C - 7	2T4-83922-02	C - 12	90201-16383	B - 10
3L5-13101-01	B - 4	2E9-15316-00	B - 8	3PT-2173L-A0	B - 14	5M0-25180-00-UJ	C - 7	3TB-83936-00	C - 9	90202-04214	B - 7
3L5-13124-00	B - 4	4J2-15363-00	B - 8	3PT-21741-60	B - 14	4N0-25181-01	C - 7		C - 12	90208-10012	B - 10
384-13138-00	B - 4	4J2-15415-00	B - 8	4X4-21751-00	B - 15	2T4-25185-00	C - 7		C - 12	90209-10160	C - 4
3L5-13161-00	B - 4	3L5-15416-00	B - 4	4X4-21766-01	B - 15			437-83936-01	C - 12	90240-08084	C - 10
3L5-13178-00	B - 9	4X4-15421-02	B - 8	1Y1-21770-01	B - 15	4X4-25336-00	C - 8	437-83936-11	C - 9	90249-12008	C - 9
3L5-13555-00	B - 5	3L5-15426-00	B - 4	4X4-21773-00	B - 15	3L5-25351-00	C - 8	4Y4-85520-M0	C - 11	90280-03017	B - 3
3L5-13610-00	B - 5	3L5-15451-11	B - 8	3L7-22110-00-98	C - 2	3L5-25355-00	C - 8	3PT-85540-00	C - 13	90282-05034	B - 10
3L5-13613-00	B - 5	4X4-15484-00	B - 8	4X4-22110-10	C - 2	5M0-25390-00-UJ	C - 8	4J2-85546-00	C - 13	90282-05033	C - 7
3L5-13616-00	B - 5	4X4-15491-00	B - 8	4J2-22174-01	C - 2	36E-2539F-00	C - 7	3L6-85550-M1	C - 11	90336-15033	C - 7
3HK-13621-00	B - 5	3L5-15601-00	B - 9	3PT-22210-10	C - 2			3PT-85560-00	C - 11	90387-077F4	C - 5
3L5-13622-10	B - 5	2T4-15618-00	B - 9	164-22216-00	C - 2	2E9-25412-00	C - 8	3L5-85580-M0	C - 11	90387-10620	C - 7
3L5-13624-00	B - 5	17J-15620-01	B - 9			3PT-26111-00	C - 9	5PG-85590-00	C - 13	90387-125A5	C - 8
5PG-14101-10	B - 6	3L5-15631-00	B - 9	3PT-23100-01-35	C - 4	36R-26124-10	C - 9	3PT-W253A-10	C - 7	90387-16730	B - 10
36R-14103-00	B - 6	3L5-15664-00	B - 9	3PT-23103-00-35	C - 4	2E9-26129-00	C - 9		C - 8	90401-10029	B - 4
36R-14104-00	B - 6	3L5-15673-00	B - 9	4X4-23106-00-35	C - 4	4X4-26241-00	C - 9	90101-05396	C - 8	90430-04004	B - 4
17L-14106-00	B - 6	3L5-16111-00	B - 10	3PT-23110-00	C - 4	4X4-26242-00	C - 9	90101-08461	C - 2	90430-08119	B - 8
3L5-14112-40	B - 6	3L5-16114-00	B - 10	2E9-23113-01	C - 4	4X4-26243-00	C - 9	90105-08066	C - 2	90445-09251	C - 5
174-14131-01	B - 6	3L5-16115-00	B - 10	54V-23125-02	C - 4	4X4-26257-00	C - 12	90105-08103	B - 8	90445-095J0	C - 5
127-14135-00	B - 6	3L5-16125-00	B - 10	4X4-23141-00	C - 4	266-26261-00	C - 9	90105-08121	C - 2	90465-10098	C - 12
3L7-14141-12	B - 6	3L5-16181-01	B - 10	2E9-23143-00	C - 4	5L6-26272-00	C - 9	90105-10006	C - 4	90467-08003	B - 15
3L5-14142-40	B - 6	3L5-16611-02	B - 10	2E9-23144-01	C - 4	4X4-26311-10	C - 9	90105-10110	B - 12		C - 5
1R0-14169-00	B - 6	3L5-16620-03	B - 10	36R-23151-00	C - 4	5PG-26312-00	C - 9	90109-08582	B - 8	90467-12052	C - 5
127-14171-00	B - 6	3L5-16627-02	B - 10	3L6-23195-00	C - 4	4X4-26321-10	C - 9	90116-06418	B - 2	90467-20023	B - 5
3L5-14184-00	B - 6	3L5-16628-02	B - 10	3PT-23340-00	C - 4	4X4-26331-01	C - 9	90119-06060	B - 14	90467-22048	B - 7
3L6-14185-01	B - 6	2T4-16629-00	B - 10	3PT-23411-00	C - 4	3PT-26341-00	C - 9	90149-04135	B - 4	90468-02033	B - 4
603-14186-00	B - 6	3L5-16633-02	B - 10	2E9-23412-00	C - 4	4X4-26351-10	C - 9	90149-05119	C - 12	90468-12006	C - 10
3L5-14190-01	B - 6	3L5-17112-01	B - 8	2E9-23413-01	C - 4	4X4-27111-00-33	C - 10	90149-05162	C - 12	90480-10408	B - 15
214-14197-00	B - 6	3L5-17410-00	B - 11	3YJ-23414-00	C - 4	4X4-27114-00	C - 10	90149-35133	C - 3	90480-18290	C - 5
3L5-14198-00	B - 6	3L5-17442-00	B - 11	4X4-23435-00	C - 4	3L5-27151-02	C - 10	90149-45134	B - 11	90501-08410	B - 15
620-14231-14	B - 6	3L5-17471-00	B - 11	5PG-24110-10	C - 5	4X4-27143-00	C - 10	90153-06011	B - 7	90501-10074	C - 9
1V3-14271-00	B - 6	3L5-17473-00	B - 11	3HA-24141-00	B - 12	214-27421-00	C - 10	90157-05003	B - 7	90501-10513	C - 9
4X4-14411-00	B - 5	3L5-17531-00	B - 11	3ME-2415E-01	B - 14	4X4-28100-00	B - 14	90159-06013	B - 5	90501-60556	C - 3
								90159-06058	B - 14	90506-29052	C - 10

NUMERICAL INDEX

PART NO.	GRID NO.	PART NO.	GRID NO.	PART NO.	GRID NO.	PART NO.	GRID NO.	PART NO.	GRID NO.	PART NO.	GRID NO.
90508-20023	C - 10	93430-07012	B - 4	98507-06045	B - 5						
90508-28399	B - 9	93440-17138	C - 3		B - 8						
90560-10173	C - 7	93450-11021	B - 3	98517-04012	C - 11						
90560-15315	C - 3	93450-30057	C - 4	98517-04025	C - 11						
90560-25185	C - 3	93505-32042	C - 4	98607-05112	B - 6						
91317-06070	C - 10	94125-10650	C - 7	98707-06016	C - 11						
91318-06016	B - 11		C - 8	98807-05100	B - 6						
91401-25015	C - 10	94125-10651	C - 7	99009-16400	B - 10						
91609-30014	B - 4		C - 8	99530-12016	B - 8						
91701-08078	C - 10	94225-10270	C - 7								
92903-10200	C - 7		C - 8								
92907-03100	B - 5	94701-00258	B - 2								
92907-04100	B - 6	94703-00258	B - 2								
		95027-06016	C - 3								
92907-06100	B - 7	95027-08030	C - 4								
	B - 8	95307-05600	C - 7								
		95307-12700	B - 3								
	C - 2	95607-05100	C - 12								
	C - 13	95607-08100	C - 9								
92907-06600	B - 5	95607-10200	B - 12								
	B - 7	95707-06500	B - 2								
	C - 5		C - 5								
	C - 13	95707-08500	C - 2								
92907-08100	B - 7	97007-05020	C - 7								
	C - 2	97007-06016	B - 7								
92907-08600	B - 7		C - 13								
	C - 10	97007-06090	C - 5								
92907-12100	B - 3	97007-08020	B - 7								
92907-12600	B - 3	97017-06016	C - 3								
93101-10001	B - 4	97017-06025	B - 9								
93102-15267	B - 11	97027-06016	C - 2								
93102-17067	B - 3	97707-50115	B - 4								
93102-23174	B - 3	98507-03010	B - 5								
93106-17015	C - 7	98507-04006	C - 11								
93106-24018	C - 2	98507-04010	C - 11								
93109-15001	B - 9	98507-04014	B - 6								
93109-34057	C - 7	98507-05014	B - 8								
93210-14104	B - 8	98507-05020	B - 4								
93210-26240	B - 4	98507-05025	C - 12								
93211-066A9	C - 3	98507-05030	B - 6								
93306-20006	C - 7	98507-05035	B - 4								
93306-20111	C - 3	98507-06008	B - 7								
93306-20117	C - 2	98507-06010	C - 5								
93306-20203	C - 3	98507-06012	B - 8								
93306-20205	C - 3	98507-06016	C - 13								
93306-20301	B - 11	98507-06020	B - 5								
93306-20326	B - 3	98507-06025	B - 8								
93310-21038	B - 3	98507-06035	B - 8								
93310-416N7	B - 3		B - 8								