



PARTS CATALOGUE

TW200E'06 (5FYY) SOUTH AFRICA

TW200V
TW200VC/TW200E
PARTS CATALOGUE
©2005 by Yamaha Motor Co., Ltd.
1st edition, June 2005
All rights reserved.
Any reprinting or unauthorized use
without the written permission of
Yamaha Motor Co., Ltd.
is expressly prohibited.
Printed in Japan.

A3



A4

FOREWORD

This Parts Catalogue is related to the parts for the model(s) on the cover page. When you are ordering replacement parts, please refer to this Parts Catalogue and quote both part numbers and part names correctly.

1. Modifications or additions which have been made after the issue of the Parts Catalogue will be announced in the Parts News.

It is advisable that you make the necessary corrections to the Parts Catalogue according to the Parts News.

2. Abbreviations

The following abbreviations are used in this Parts Catalogue.

“UR” Use specified parts number.

“UN” Use as many as needed.

“AP” Alternate Parts

“LM” Locally Made (Parts need to be ordered locally)

“F#” Frame No. (Applicable machine No.)

“O/S” Over Size

3. The number of components for assembly

- Parts, which are to be supplied in an assembly, are listed with a dot (.) in front of the part name as shown below.
- The numeral appearing to the right of each component part indicates the quantity of parts for each assembly unit.

PART NO.	DESCRIPTION	Q'TY	REMARKS
2F5-83310-60	FRONT FLASHER LIGHT ASSY	2	
115-83311-60	.BULB (6V-18W)	1	

4. Applicable colours of graphics are represented in the “REMARKS” as shown below.

PART NO.	DESCRIPTION	Q'TY	REMARKS
2N4-24110-00-X5	FUEL TANK COMP.	2	MXR
3J1-24240-10	.GRAPHIC, FUEL TANK	1	FOR MXR

5. Note that the illustrations for reference in finding parts numbers are not to be used for assembling. When assembling, please use the applicable service manual.

6. The asterisk (*) before a reference number indicates modified items after the first edition.

FOREWORD

7. Applicable Serial No.

Engine Serial No.

Frame Serial No.

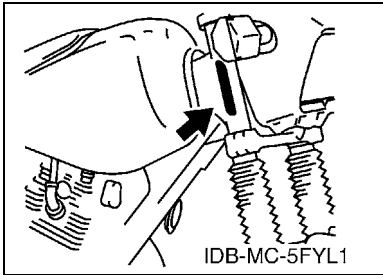
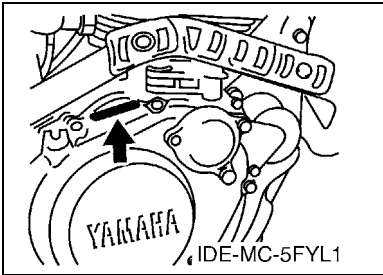

8. Applicable Colour Code (The (*) mark shows Model colour.)

Abbreviation	Colour Name	Colour Code
DPBMC(*)	DEEP PURPLISH BLUE METALLIC C	0564
LGB	LOW GLOSS BLACK	0098
LRYS1	LIGHT REDDISH YELLOW SOLID 1	0386
S8	SILVER 8	0895
SL	SILVER	0035
ZK	*UNI-CHROME (BLACK CHROMATE)	0090

CONTENTS

ENGINE

CYLINDER HEAD	B2
CYLINDER	B3
CRANKSHAFT & PISTON	B4
VALVE	B6
CAMSHAFT & CHAIN	B7
OIL PUMP	B8
INTAKE	B9
CARBURETOR	B10
EXHAUST	B12
CRANKCASE	B13
CRANKCASE COVER 1	B14
STARTER	B15
CLUTCH	C3
TRANSMISSION	C5
SHIFT CAM & FORK	C7
SHIFT SHAFT	C8

CHASSIS

FRAME	C9
FENDER	C11
SIDE COVER	C13
REAR ARM	C14
REAR SUSPENSION	C15
STEERING	D2
FRONT FORK	D3
FUEL TANK	D5
SEAT	D7
FRONT WHEEL	D8
FRONT BRAKE CALIPER	D9
REAR WHEEL	D10
STEERING HANDLE & CABLE	D12
FRONT MASTER CYLINDER	D13
STAND & FOOTREST	D14
COWLING 1	E2
GENERATOR	E3
STARTING MOTOR	E4
FLASHER LIGHT	E5
FLASHER LIGHT 2	E6
METER	E7
HEADLIGHT	E8
TAILLIGHT	E9

TAILLIGHT 2	E10
HANDLE SWITCH & LEVER	E11
ELECTRICAL 1	E12

INDEX

NUMERICAL INDEX	M1
-----------------------	----

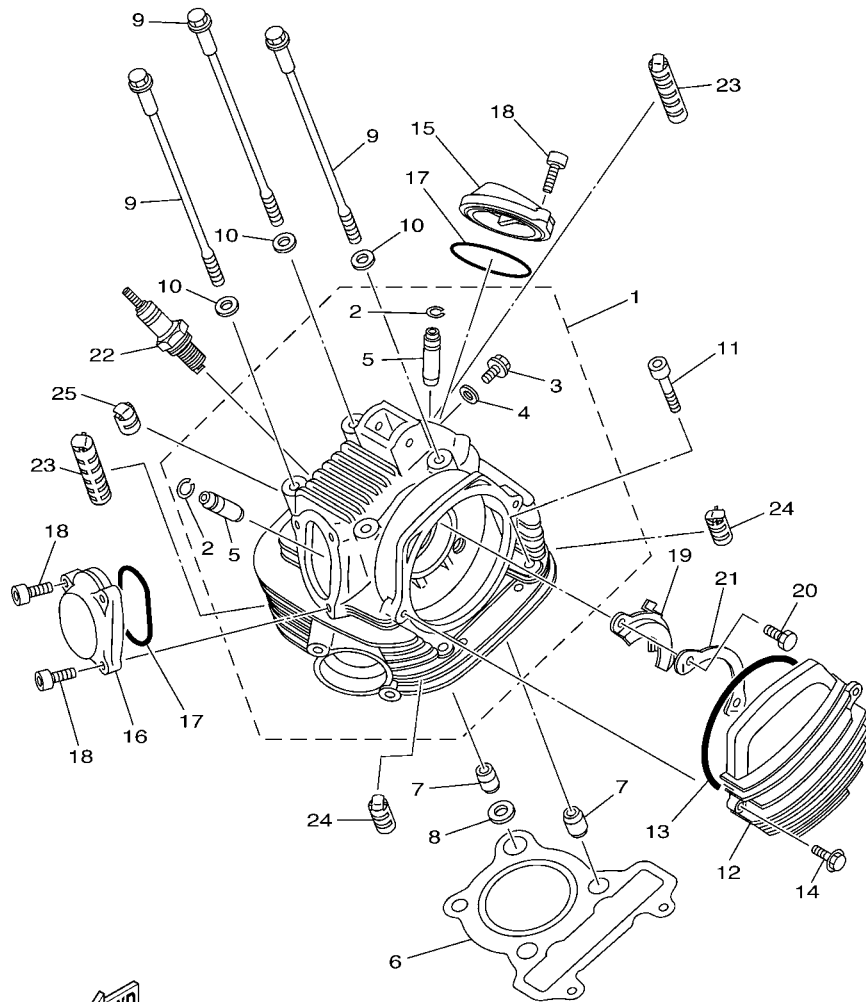

5FY8100-1010

FIG. 1 CYLINDER HEAD

REF. NO.	PART NO.	DESCRIPTION	5FY	5FYW	5FYX	3XTG	5FY	REMARKS
1	15A-11110-04	CYLINDER HEAD ASSY	1	1	1	1	1	
2	93440-10085	.CIRCLIP	2	2	2	2	2	
3	90153-06029	.SCREW, HEXAGON	1	1	1	1	1	
4	90430-06014	.GASKET	1	1	1	1	1	
5	5H0-11133-11	.GUIDE, VALVE 1	2	2	2	2	2	
6	1NU-11181-00	GASKET, CYLINDER HEAD 1	1	1	1	1	1	
7	99530-14016	PIN, DOWEL	3	3	3	3	3	
8	90430-14131	GASKET	1	1	1	1	1	
9	90105-08195	BOLT, FLANGE	4	4	4	4	4	
10	90201-08609	WASHER, PLATE	4	4	4	4	4	
11	91317-08045	BOLT	2	2	2	2	2	
12	15A-11185-00	COVER, CYLINDER HEAD SIDE 1	1	1	1	1	1	
13	93211-05471	O-RING	1	1	1	1	1	
14	95027-06020	BOLT, FLANGE	2	2	2	2	2	
15	15A-11186-00	COVER, CYLINDER HEAD SIDE 2	1	1	1	1	1	
16	15A-11187-00	COVER, CYLINDER HEAD SIDE 3	1	1	1	1	1	
17	93210-57634	O-RING	2	2	2	2	2	
18	91317-06018	BOLT	5	5	5	5	5	
19	5H0-1111F-00	PLATE	1	1	1	1	1	
20	97007-06012	BOLT	2	2	2	2	2	
21	90215-06184	WASHER, LOCK	1	1	1	1	1	
22	94701-00333	PLUG, SPARK (NGK DR8EA)	1	1	1	1	1	UR
	94701-00222	PLUG, SPARK (ND X24ESR-U)	1	1	1	1	1	UR
23	15A-11162-00	ABSORBER 2	2	2	2	2	2	
24	5H0-11162-00	ABSORBER 2	2	2	2	2	2	
25	15A-11161-01	ABSORBER 1	1	1	1	1	1	



5H0110-0040

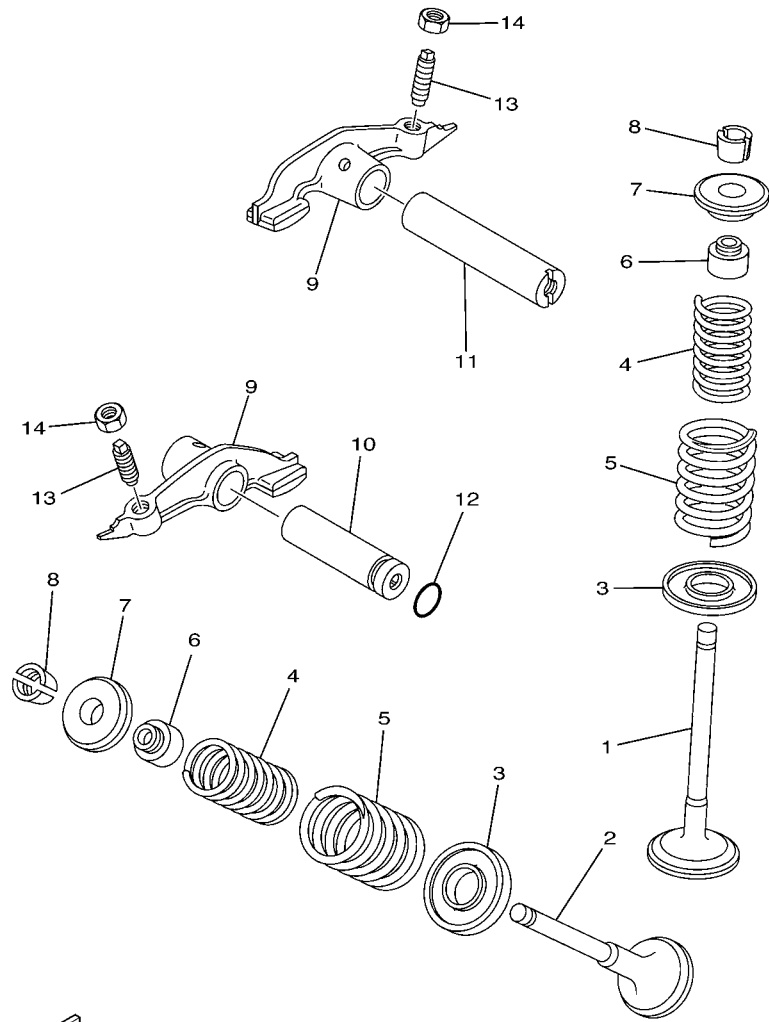
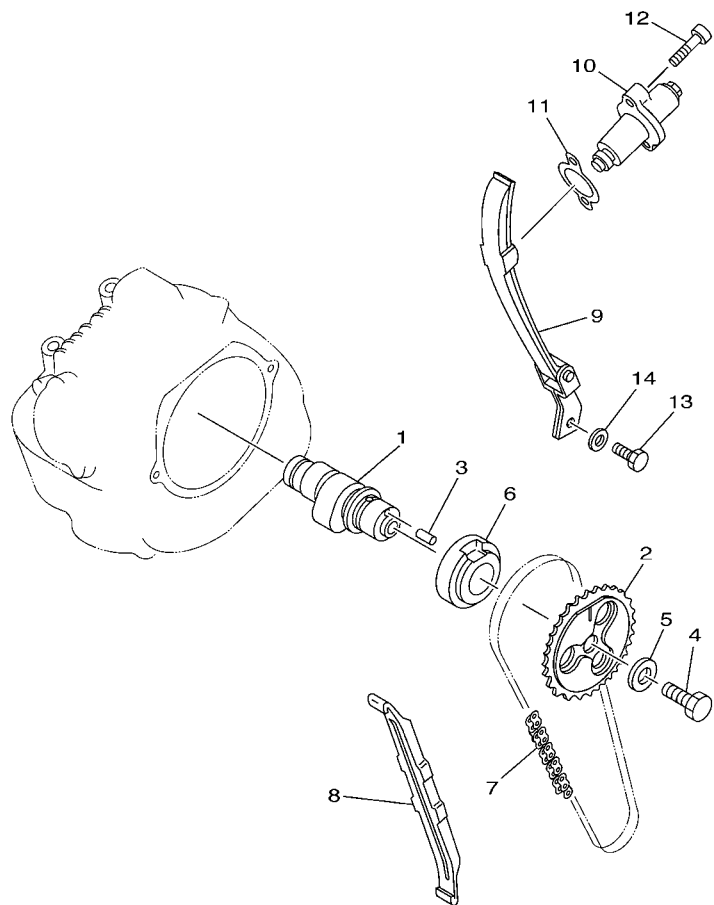

FIG. 4 VALVE

REF. NO.	PART NO.	DESCRIPTION	5FYV	5FYW	5FYX	3XTG	5FYV	REMARKS
1	5H0-12111-02	VALVE, INTAKE	1	1	1	1	1	
2	5H0-12121-01	VALVE, EXHAUST	1	1	1	1	1	
3	4G0-12116-01	SEAT, VALVE SPRING	2	2	2	2	2	
4	11H-12113-00	SPRING, VALVE INNER	2	2	2	2	2	
5	11H-12114-00	SPRING, VALVE OUTER	2	2	2	2	2	
6	5H0-12119-00	SEAL, VALVE STEM	2	2	2	2	2	
7	4G0-12117-00	RETAINER, VALVE SPRING	2	2	2	2	2	
8	4G0-12118-00	COTTER, VALVE	4	4	4	4	4	
9	36X-12151-00	ARM, VALVE ROCKER	2	2	2	2	2	
10	5H0-12156-00	SHAFT, ROCKER 2	1	1	1	1	1	
11	5H0-12146-00	SHAFT, ROCKER	1	1	1	1	1	
12	93210-09165	O-RING	1	1	1	1	1	
13	2NX-12159-00	SCREW, VALVE ADJUSTING	2	2	2	2	2	
14	90170-06128	NUT	2	2	2	2	2	

FIG. 5 CAMSHAFT & CHAIN



5FY8100-1050

REF. NO.	PART NO.	DESCRIPTION	5FY	5FYW	5FYX	3XTG	5FY	REMARKS
1	36X-12171-00	CAMSHAFT 1	1	1	1	1	1	
2	1KH-12176-00	SPROCKET, CAM CHAIN	1	1	1	1	1	
3	93604-10011	PIN, DOWEL	1	1	1	1	1	
4	90101-10303	BOLT	1	1	1	1	1	
5	90201-10591	WASHER, PLATE	1	1	1	1	1	
6	90387-255F3	COLLAR	1	1	1	1	1	
7	94580-41104	CHAIN (DID25SH 104L)	1	1	1	1	1	
8	5H0-12231-00	GUIDE, STOPPER 1	1	1	1	1	1	
9	5N0-12241-00	GUIDE, STOPPER 2	1	1	1	1	1	
10	3GC-12210-10	TENSIONER ASSY, CAM CHAIN	1	1	1	1	1	
11	4FM-12213-00	GASKET, TENSIONER CASE	1	1	1	1	1	
12	91317-06025	BOLT	2	2	2	2	2	
13	97027-06016	BOLT	2	2	2	2	2	
14	92907-06600	WASHER, PLATE	2	2	2	2	2	

FIG. 6 OIL PUMP

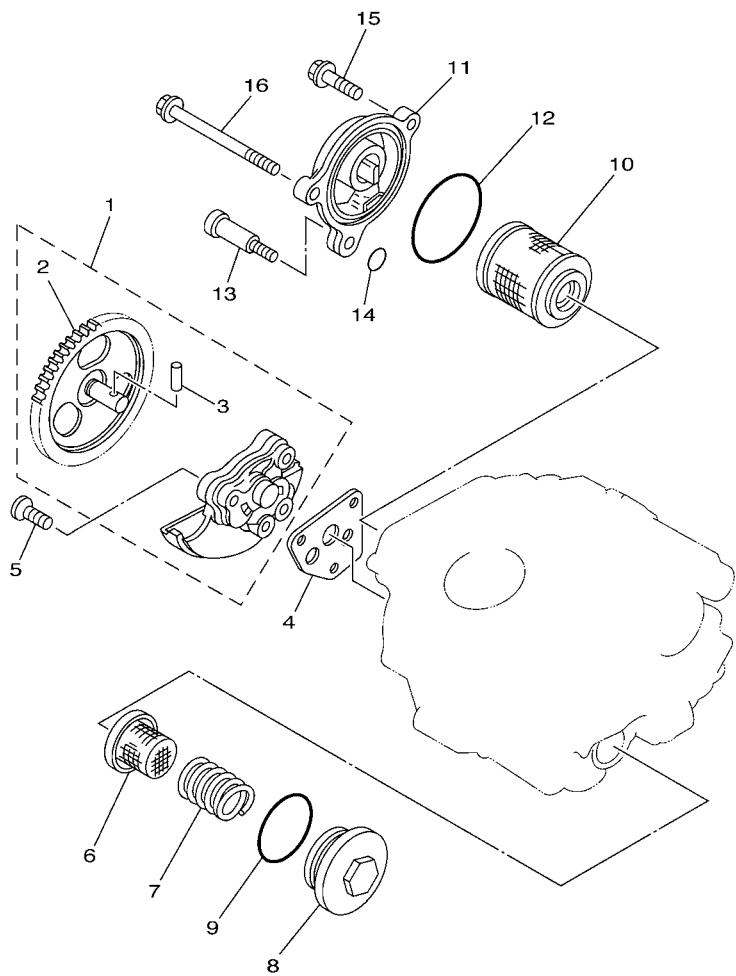

5FY8100-1060

REF. NO.	PART NO.	DESCRIPTION	5FY	5FYW	5FYX	3XTG	5FY	REMARKS
1	5H0-13300-02	OIL PUMP ASSY	1	1	1	1	1	
2	5H0-13326-01	.GEAR, PUMP DRIVEN 2 (45T)	1	1	1	1	1	
3	93603-12030	.PIN, DOWEL	1	1	1	1	1	
4	4BE-13329-01	GASKET, PUMP COVER	1	1	1	1	1	
5	98707-06030	SCREW, FLAT HEAD	3	3	3	3	3	
6	51Y-13411-00	STRAINER, OIL	1	1	1	1	1	
7	90501-18576	SPRING, COMPRESSION	1	1	1	1	1	
8	5H0-15351-00	PLUG, DRAIN	1	1	1	1	1	
9	93210-347A1	O-RING	1	1	1	1	1	
10	5H0-13440-09	ELEMENT ASSY, OIL CLEANER	1	1	1	1	1	
11	15A-13447-00	COVER, OIL ELEMENT	1	1	1	1	1	
12	93210-54175	O-RING	1	1	1	1	1	
13	90109-06419	BOLT	1	1	1	1	1	
14	93210-07135	O-RING	1	1	1	1	1	
15	95027-06025	BOLT, FLANGE	1	1	1	1	1	
16	90105-065A1	BOLT, FLANGE	1	1	1	1	1	

FIG. 7 INTAKE

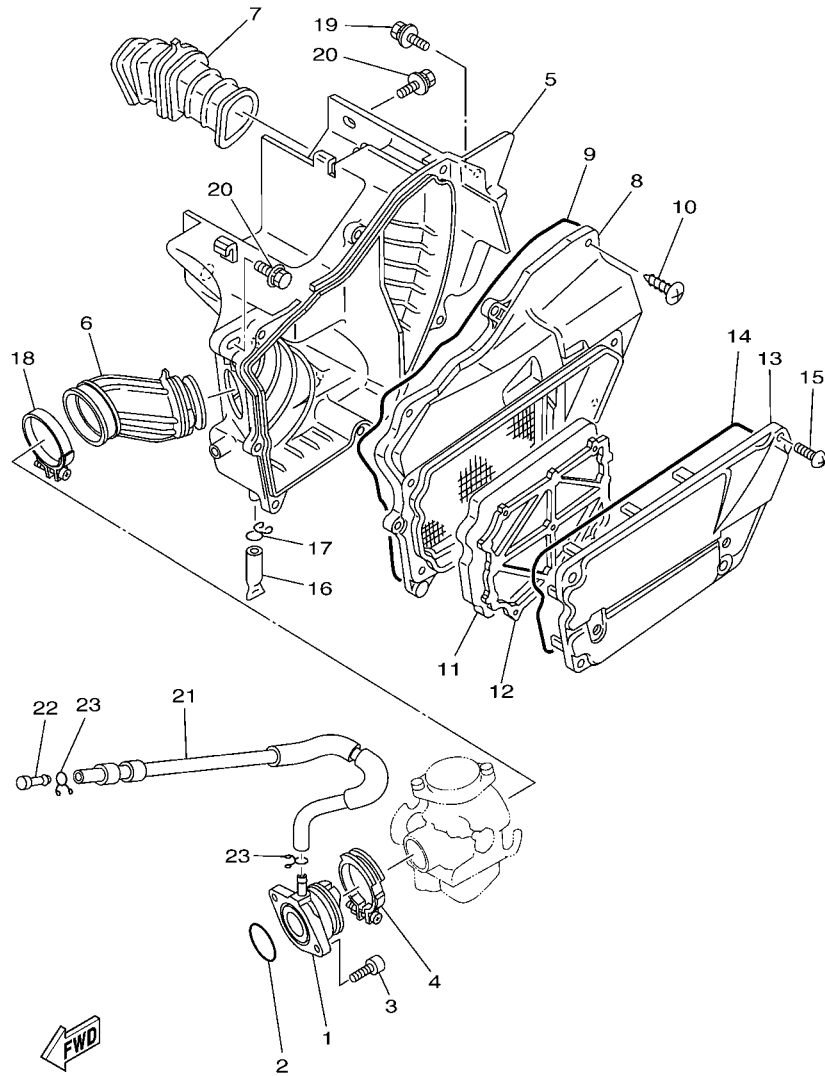

5LB1010-0080

REF. NO.	PART NO.	DESCRIPTION	5FYV	5FYW	5FYX	3XTG	5FYZ	REMARKS
1	5LB-13586-02	JOINT, CARBURETOR 1	1	1	1	1	1	
2	93210-35537	O-RING	1	1	1	1	1	
3	91317-06020	BOLT	2	2	2	2	2	
4	90450-44062	HOSE CLAMP ASSY	1	1	1	1	1	
5	2JX-14411-02	CASE, AIR CLEANER 1	1	1	1	1	1	
6	5LB-14453-10	JOINT, AIR CLEANER 1	1	1	1	1	1	
7	2JL-14437-00	DUCT	1	1	1	1	1	
8	2JX-14412-00	CAP, CLEANER CASE 1	1	1	1	1	1	
9	2JX-14452-00	SEAL	1	1	1	1	1	
10	97707-50520	SCREW, TAPPING	7	7	7	7	7	
11	2JX-14451-00	ELEMENT, AIR CLEANER	1	1	1	1	1	
12	2JX-14458-00	GUIDE	1	1	1	1	1	
13	2JX-14422-00	CAP, CLEANER CASE 2	1	1	1	1	1	
14	5U8-14457-00	SEAL	1	1	1	1	1	
15	90154-05005	SCREW, BINDING	4	4	4	4	4	
16	34X-1443E-00	PIPE, DRAIN	1	1	1	1	1	
17	90467-11106	CLIP	1	1	1	1	1	
18	90460-51059	CLAMP, HOSE	1	1	1	1	1	
19	90119-06056	BOLT, WITH WASHER	1	1	1	1	1	
20	90119-06063	BOLT, WITH WASHER	2	2	2	2	2	
21	5LB-13584-00	PIPE, INTAKE MANIFOLD	1	1	1	1	1	
22	90338-08007	PLUG	1	1	1	1	1	
23	90467-10041	CLIP	2	2	2	2	2	

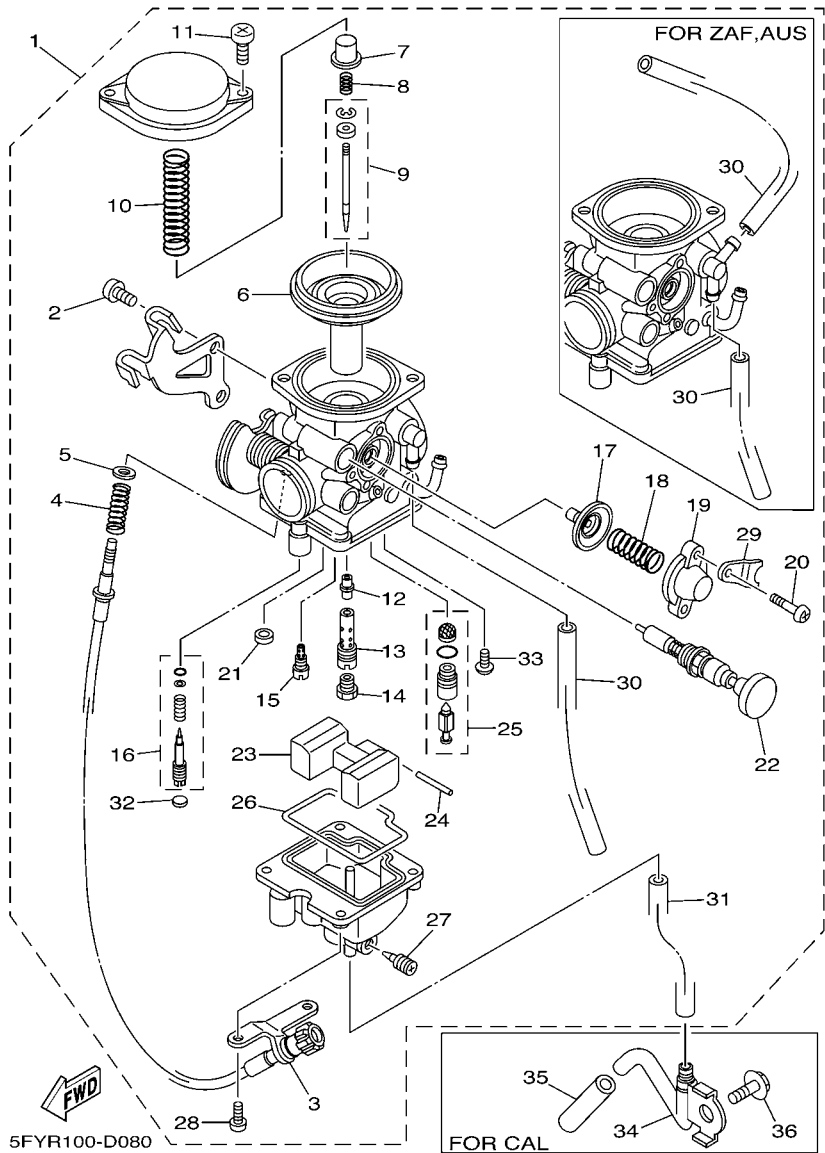
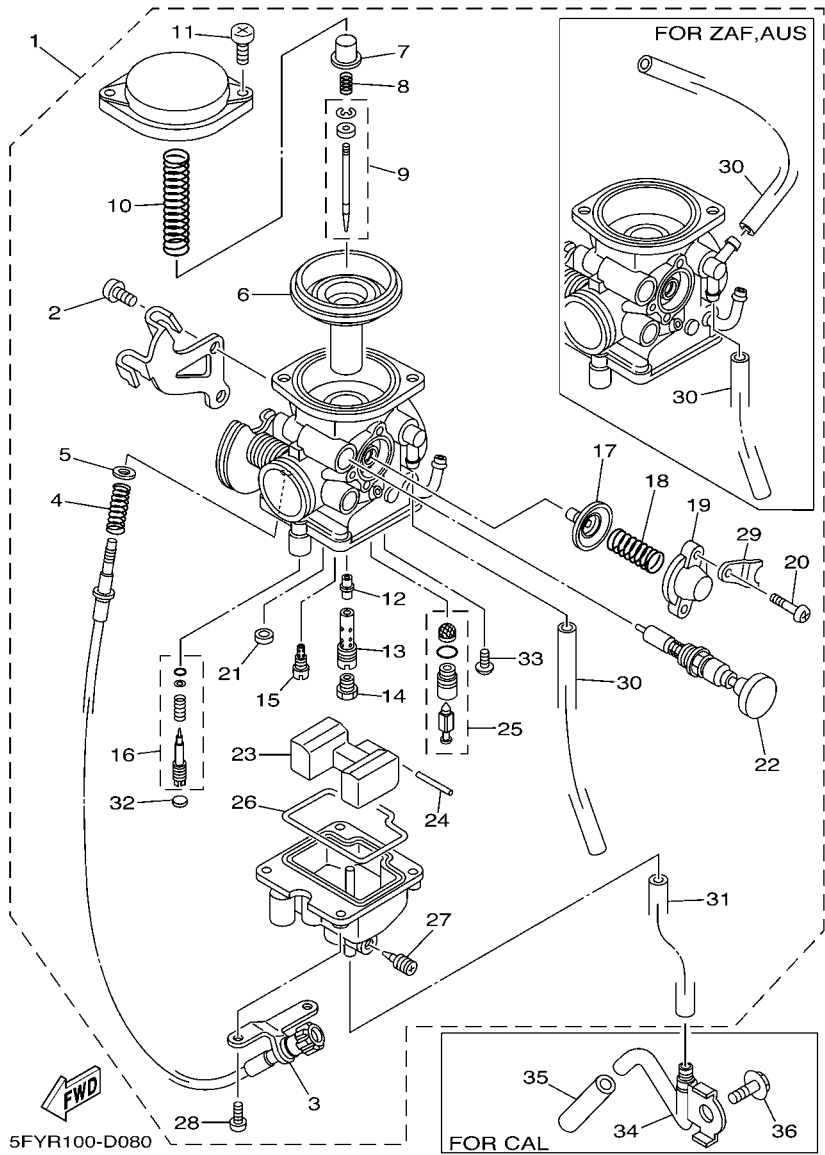

FIG. 8 CARBURETOR

REF. NO.	PART NO.	DESCRIPTION	5FYV	5FYW	5FYX	3XTG	5FYV	REMARKS
1	5LB-14301-01	CARBURETOR ASSY 1					1	
2	97801-05010	.THROTTLE SCREW	2	2	2	2	2	
3	5LB-14321-00	.SCREW, THROTTLE	1	1	1	1	1	
4	2JX-14333-00	.SPRING, THROTTLE STOP	1	1	1	1	1	
5	5LB-14357-00	.WASHER, PLAIN	1	1	1	1	1	
6	5LB-1434A-00	.SUCTION PISTON ASSY	1	1	1	1	1	
7	5LB-14936-00	.SEAT, SPRING	1	1	1	1	1	
8	5LB-14275-00	.SPRING	1	1	1	1	1	
9	5LB-14336-00	.NEEDLE					1	
10	5LB-14286-00	.SPRING	1	1	1	1	1	
11	5LB-14216-00	.SCREW	2	2	2	2	2	
12	5LB-14341-00	.NOZZLE, MAIN	1	1	1	1	1	
13	5LB-14341-10	.BLEED, MAIN NOZZLE	1	1	1	1	1	
14	288-14343-66	.JET, MAIN (#132)					1	
	288-14343-64	.JET, MAIN (#128)		1				
15	5LB-14342-65	.JET, PILOT (#31)	1	1	1	1	1	
16	5LB-14105-00	.PILOT SCREW SET	1	1	1	1	1	
17	5LB-14368-00	.DIAPHRAGM ASSY 1	1	1	1	1	1	
18	5LB-14589-00	.SPRING	1	1	1	1	1	
19	5LB-14293-00	.COVER 1	1	1	1	1	1	
20	214-24535-00	.SCREW, LEVER FITTING	2	2	2	2	2	
21	50M-14355-00	.PLUG	1	1	1	1	1	
22	5FY-14371-00	.PLUNGER, STARTER	1	1	1	1	1	



5FYR100-D080

FIG. 8 CARBURETOR

REF. NO.	PART NO.	DESCRIPTION	5FYV	5FYW	5FYX	3XTG	5FYZ	REMARKS
23	5LB-14385-00	.FLOAT	1	1	1	1	1	
24	5LB-14386-00	.PIN, FLOAT	1	1	1	1	1	
25	5LB-14390-00	.NEEDLE VALVE ASSY	1	1	1	1	1	
26	5LB-14384-00	.GASKET, FLOAT CHAMBER	1	1	1	1	1	
27	4JP-14323-00	.DRAIN, SCRE	1	1	1	1	1	
28	5LB-14592-00	.SCREW	4	4	4	4	4	
29	5LB-14292-00	.BRACKET 2	1	1	1	1	1	
30	5FY-14197-00	.PIPE	1	1	1			
	5LB-14197-00	.PIPE				2	2	
31	5FY-14196-00	.PIPE	1	1	1			
	5LB-14196-00	.PIPE				1	1	
32	4KN-1432A-00	.PLUG	1	1	1			
33	98901-04006	.SCREW, BIND	1	1	1	1	1	
34	2JX-14193-00	PIPE		1				
35	2JX-14148-01	PIPE		1				
36	95807-08012	BOLT, FLANGE		1				

FIG. 9 EXHAUST

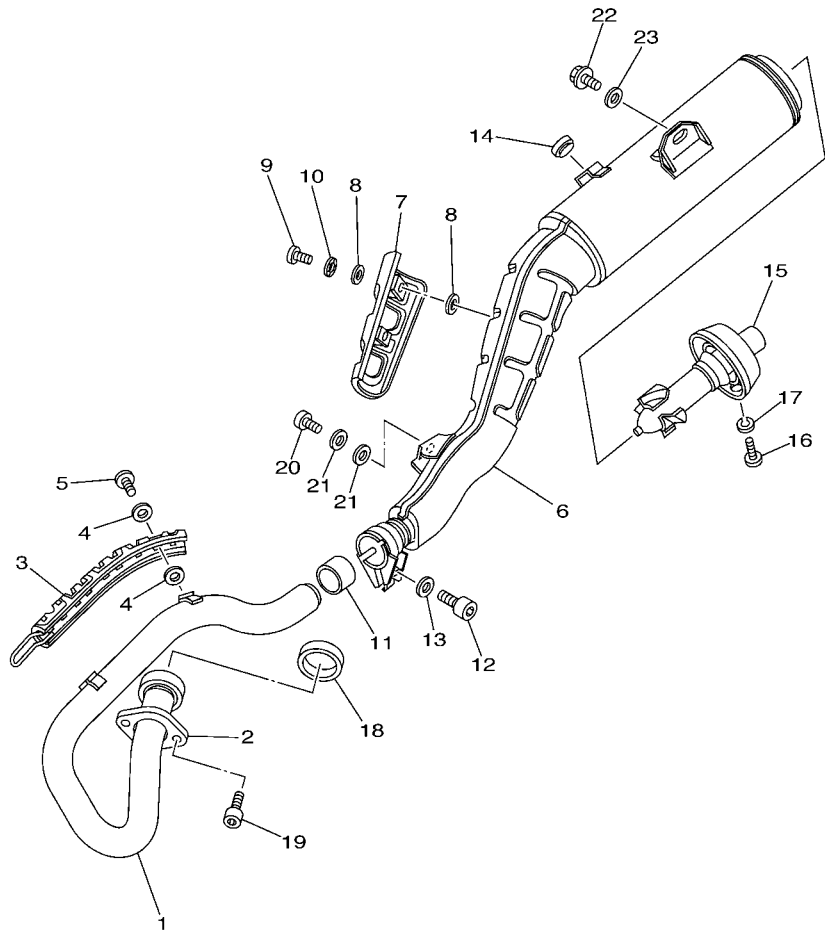

5FYG100-B090

REF. NO.	PART NO.	DESCRIPTION	5FYV	5FYW	5FYX	3XTG	5FYZ	REMARKS
1	2JX-14611-02	PIPE, EXHAUST 1	1	1	1	1	1	
2	5H0-14612-01	NUT, RING	1	1	1	1	1	
3	5LB-14628-00	PROTECTOR, EXHAUST PIPE	1	1	1	1	1	
4	90201-05015	WASHER, PLATE	4	4	4	4	4	
5	98907-06010	SCREW, BIND	2	2	2	2	2	
6	2JL-14711-21	MUFFLER 1					1	
7	2JX-14728-00	PROTECTOR, MUFFLER 2	1	1	1	1	1	
8	90202-05191	WASHER, PLATE	4	4	4	4	4	
9	98907-06010	SCREW, BIND	2	2	2	2	2	
10	90206-06090	WASHER, WAVE	2	2	2	2	2	
11	3YF-14714-00	GASKET, MUFFLER	1	1	1	1	1	
12	91317-08025	BOLT	1	1	1	1	1	
13	92907-08600	WASHER, PLATE	1	1	1	1	1	
14	22W-24181-00	DAMPER, LOCATING 1	1	1	1	1	1	
15	N/A							
16	N/A							
17	N/A							
18	4BE-14613-00	GASKET, EXHAUST PIPE	1	1	1	1	1	
19	91317-06020	BOLT	2	2	2	2	2	
20	91317-08016	BOLT	1	1	1	1	1	
21	90201-08326	WASHER, PLATE	2	2	2	2	2	
22	95817-08016	BOLT, FLANGE	1	1	1	1	1	
23	90201-08326	WASHER, PLATE	1	1	1	1	1	

FIG. 10 CRANKCASE

REF. NO.	PART NO.	DESCRIPTION	5FYV	5FYW	5FYX	3XTG	5FYZ	REMARKS
1	1RL-15100-03	CRANKCASE ASSY	1	1	1	1	1	
2	99530-12016	.PIN, DOWEL	2	2	2	2	2	
3	371-11167-01	.PIPE, BREATHER 2	1	1	1	1	1	
4	95027-06040	.BOLT, FLANGE	2	2	2	2	2	
5	90387-125F1	COLLAR	1	1	1	1	1	
6	90387-125F1	COLLAR	1	1	1	1	1	
7	95027-06030	BOLT, FLANGE	7	7	7	7	7	
8	95027-06090	BOLT, FLANGE	2	2	2	2	2	
9	95027-06085	BOLT, FLANGE	1	1	1	1	1	
10	90430-06014	GASKET	1	1	1	1	1	
11	3Y1-11166-00	PIPE, BREATHER 1	1	1	1	1	1	
12	90467-14015	CLIP	2	2	2	2	2	
13	90465-08020	CLAMP	1	1	1	1	1	
14	90462-08225	CLAMP	1	1	1	1	1	
15	90462-08224	CLAMP	1	1	1	1	1	
16	90465-08127	CLAMP	1	1	1	1	1	

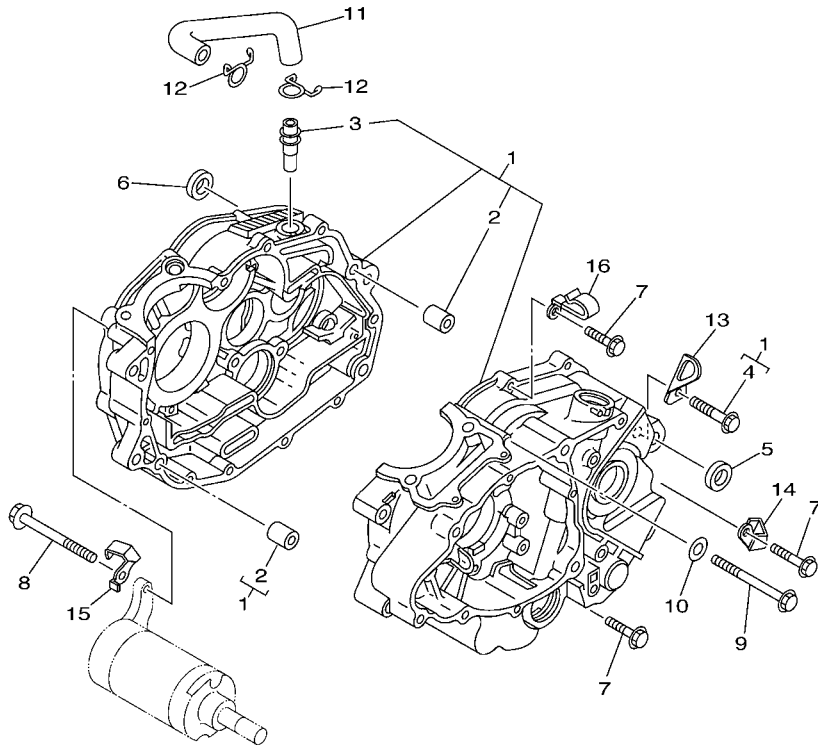

5FY8100-1100

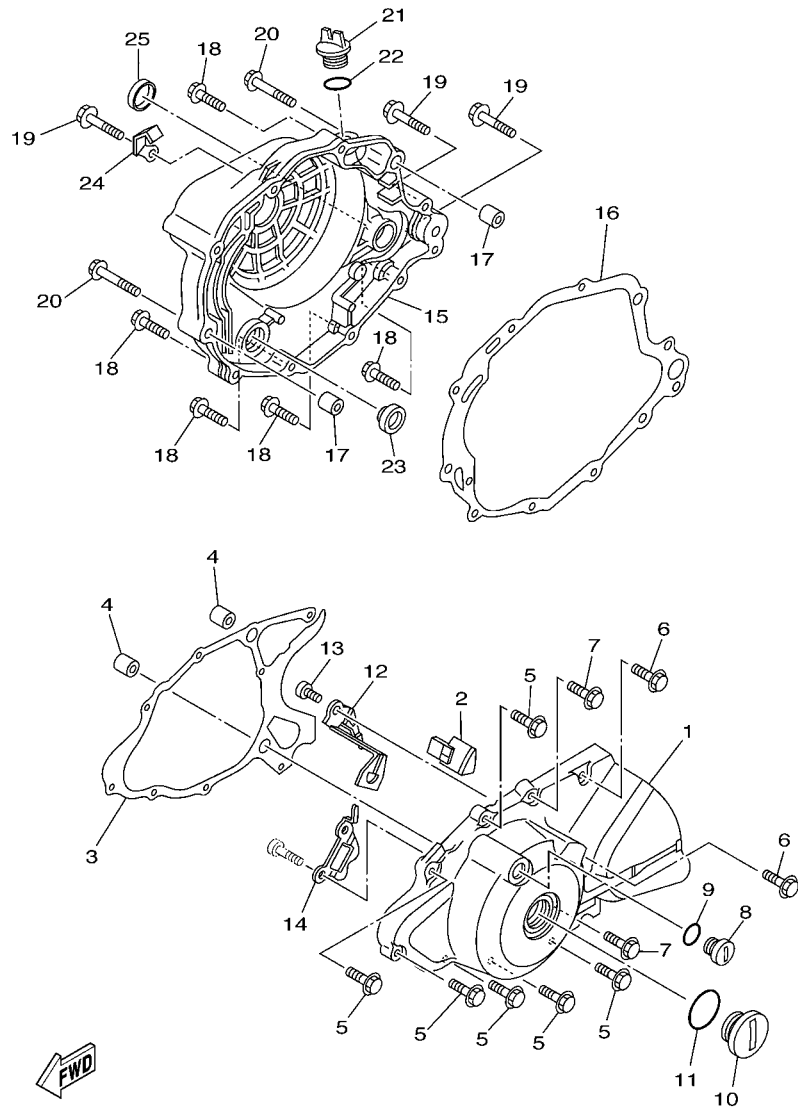

5FY8100-1110

FIG. 11 CRANKCASE COVER 1

REF. NO.	PART NO.	DESCRIPTION	5FYV	5FYW	5FYX	3XTG	5FYV	REMARKS
1	5EK-15410-00	CRANKCASE COVER ASSY 1	1	1	1	1	1	
2	2JX-15377-00	GUIDE, INLET	1	1	1	1	1	
3	3AW-15451-03	GASKET, CRANKCASE COVER 1	1	1	1	1	1	
4	99530-12016	PIN, DOWEL	2	2	2	2	2	
5	95027-06025	BOLT, FLANGE	6	6	6	6	6	
6	90105-06017	BOLT, FLANGE	2	2	2	2	2	
7	90105-06014	BOLT, FLANGE	2	2	2	2	2	
8	90340-14117	PLUG, STRAIGHT SCREW	1	1	1	1	1	
9	93210-14369	O-RING	1	1	1	1	1	
10	90340-32080	PLUG, STRAIGHT SCREW	1	1	1	1	1	
11	93210-32172	O-RING	1	1	1	1	1	
12	90465-08364	CLAMP	1	1	1	1	1	
13	91317-06010	BOLT	1	1	1	1	1	
14	90465-16187	CLAMP	1	1	1	1	1	
15	15A-15431-01	COVER, CRANKCASE 3	1	1	1	1	1	
16	4BE-15462-00	GASKET, CRANKCASE COVER 3	1	1	1	1	1	
17	99530-12016	PIN, DOWEL	2	2	2	2	2	
18	95027-06025	BOLT, FLANGE	5	5	5	5	5	
19	95027-06035	BOLT, FLANGE	3	3	3	3	3	
20	95027-06045	BOLT, FLANGE	2	2	2	2	2	
21	3Y1-15363-00	PLUG, OIL	1	1	1	1	1	
22	93210-19123	O-RING	1	1	1	1	1	
23	3Y1-15361-00	GAUGE, LEVEL	1	1	1	1	1	
24	90462-08225	CLAMP	1	1	1	1	1	
25	N/A							

FIG. 12 STARTER

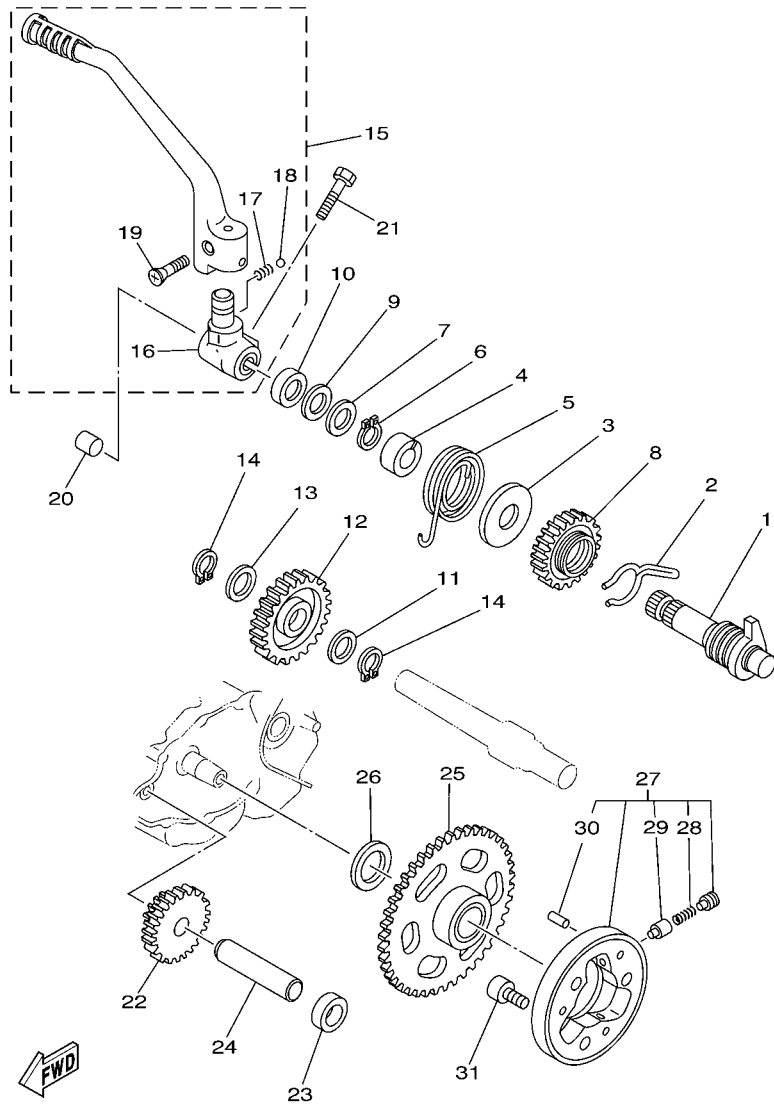

5LB1010-0141

REF. NO.	PART NO.	DESCRIPTION	5FYV	5FYW	5FYX	3XTG	5FYV	REMARKS
1	15A-15660-01	KICK AXLE ASSY				1	1	
2	90468-26122	CLIP				1	1	
3	401-15676-00	COVER, SPRING				1	1	
4	15A-15666-00	SPACER				1	1	
5	90508-26538	SPRING, TORSION				1	1	
6	99009-17400	CIRCLIP				1	1	
7	90201-175F6	WASHER, PLATE				1	1	
8	36X-15641-00	GEAR, KICK (27T)				1	1	
9	90209-17226	WASHER				1	1	
10	93102-17263	OIL SEAL				1	1	
11	90201-173F4	WASHER, PLATE				1	1	
12	15A-15651-01	GEAR, KICK IDLE (28T)				1	1	
13	90214-17028	WASHER, CLAW				1	1	
14	99009-17400	CIRCLIP				2	2	
15	54G-15620-00	KICK CRANK ASSY				1	1	
16	54G-15621-00	.BOSS, KICK CRANK				1	1	
17	90501-12081	.SPRING, COMPRESSION				1	1	
18	93507-32009	.BALL				1	1	
19	90152-06010	.SCREW, COUNTERSUNK				1	1	
20	90338-18014	PLUG				1	1	
21	97027-08030	BOLT				1	1	
22	2HT-15512-00	GEAR, IDLER 1 (41T/10T)	1	1	1	1	1	
23	90387-125Y0	COLLAR	1	1	1	1	1	
24	5H0-15521-00	SHAFT 1	1	1	1	1	1	
25	5H0-15517-00	GEAR, IDLER 2 (56T)	1	1	1	1	1	
26	90201-25290	WASHER, PLATE	1	1	1	1	1	
27	4H7-15580-10	STARTER CLUTCH OUTER ASSY	1	1	1	1	1	

FIG. 12 STARTER

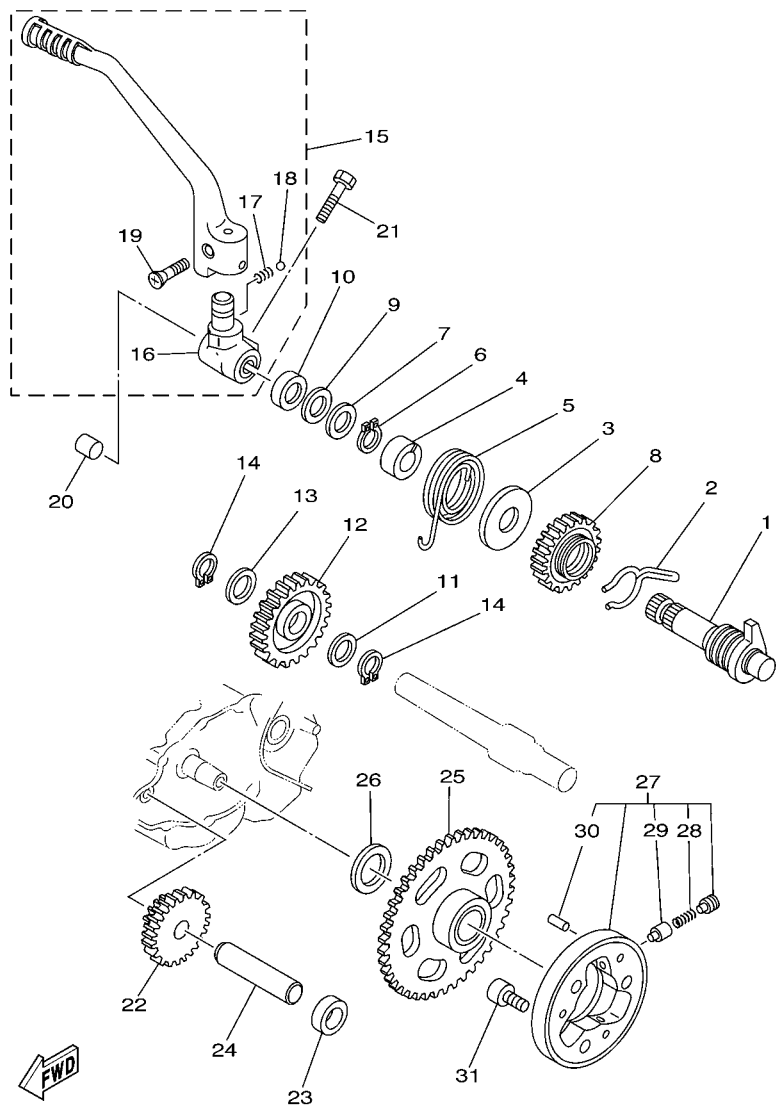

5LB1010-0141

REF. NO.	PART NO.	DESCRIPTION	5FYV	5FYW	5FYX	3XTG	5FYZ	REMARKS
28	90501-04596	.SPRING, COMPRESSION	3	3	3	3	3	
29	1J7-15583-01	.CAP, STARTER CLUTCH SPRING	3	3	3	3	3	
30	93615-12088	.PIN, DOWEL	3	3	3	3	3	
31	91317-08020	BOLT	3	3	3	3	3	

FIG. 13 CLUTCH

REF. NO.	PART NO.	DESCRIPTION	5FYV	5FYW	5FYX	3XTG	5FYV	REMARKS
1	5H0-16111-00	GEAR, PRIMARY DRIVE (22T)	1	1	1	1	1	
2	90282-05043	KEY, STRAIGHT	1	1	1	1	1	
3	90215-14205	WASHER, LOCK	1	1	1	1	1	
4	90170-14284	NUT	1	1	1	1	1	
5	15A-16150-00	PRIMARY DRIVEN GEAR COMP.73/17	1	1	1	1	1	
6	5H0-16154-00	PLATE, THRUST 1	1	1	1	1	1	
7	2JX-16371-00	BOSS, CLUTCH	1	1	1	1	1	
8	537-16321-00	PLATE, FRICTION	5	5	5	5	5	
9	137-16324-00	PLATE, CLUTCH 1	4	4	4	4	4	
10	5H0-16351-00	PLATE, PRESSURE 1	1	1	1	1	1	
11	90501-23700	SPRING, COMPRESSION	4	4	4	4	4	
12	90159-05011	SCREW, WITH WASHER	4	4	4	4	4	
13	1W1-16358-01	PLATE, PUSH	1	1	1	1	1	
14	2JX-16356-00	ROD, PUSH 1	1	1	1	1	1	
15	93210-48364	O-RING	1	1	1	1	1	
16	92907-06200	WASHER	1	1	1	1	1	
17	95307-06600	NUT	1	1	1	1	1	
18	90215-14186	WASHER, LOCK	1	1	1	1	1	
19	90170-14284	NUT	1	1	1	1	1	
20	15A-16380-00	PUSH LEVER ASSY	1	1	1	1	1	
21	90430-08119	GASKET	1	1	1	1	1	
22	90149-08067	SCREW	1	1	1	1	1	
23	90508-18537	SPRING, TORSION	1	1	1	1	1	
24	5H0-16357-00	ROD, PUSH 2	1	1	1	1	1	
25	93505-16006	BALL	1	1	1	1	1	
26	90386-14103	BUSH	1	1	1	1	1	
27	93102-14209	OIL SEAL	1	1	1	1	1	

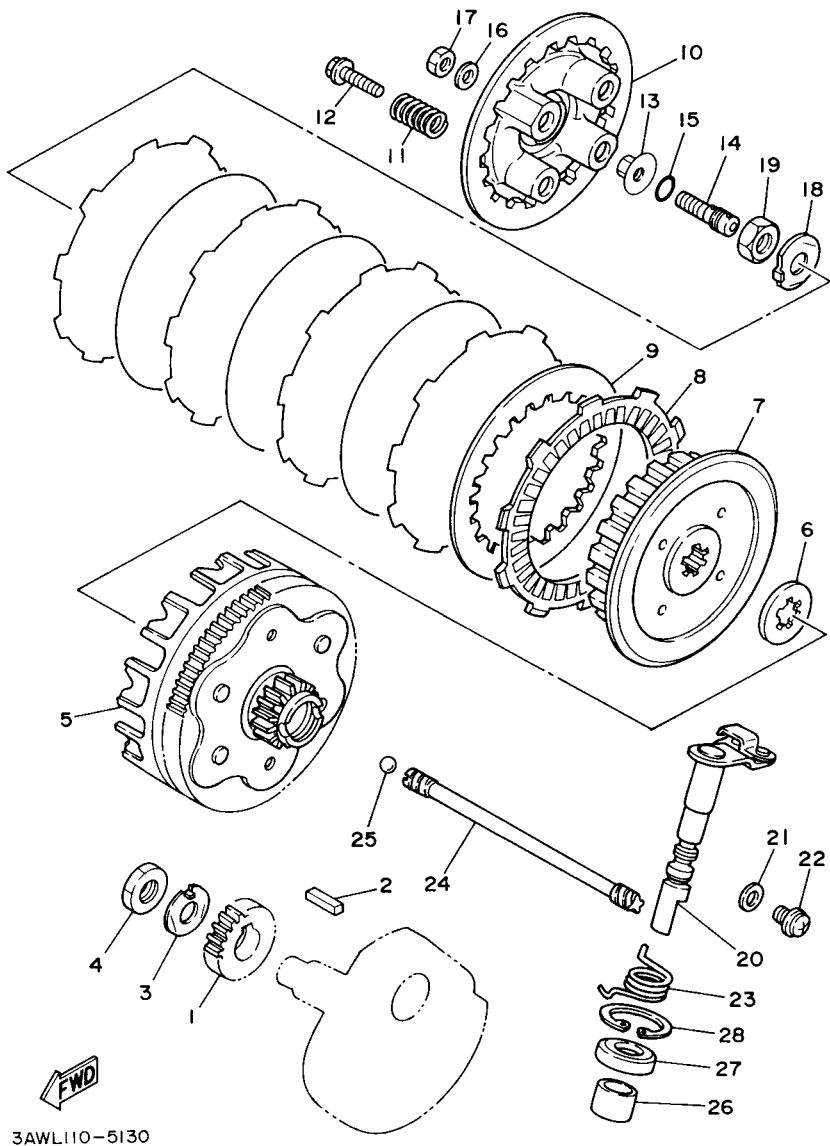

3AWL110-5130

FIG. 13 CLUTCH

REF. NO.	PART NO.	DESCRIPTION	5FYV	5FYW	5FYX	3XTG	5FYV	REMARKS
28	93420-28055	CIRCLIP	1	1	1	1	1	

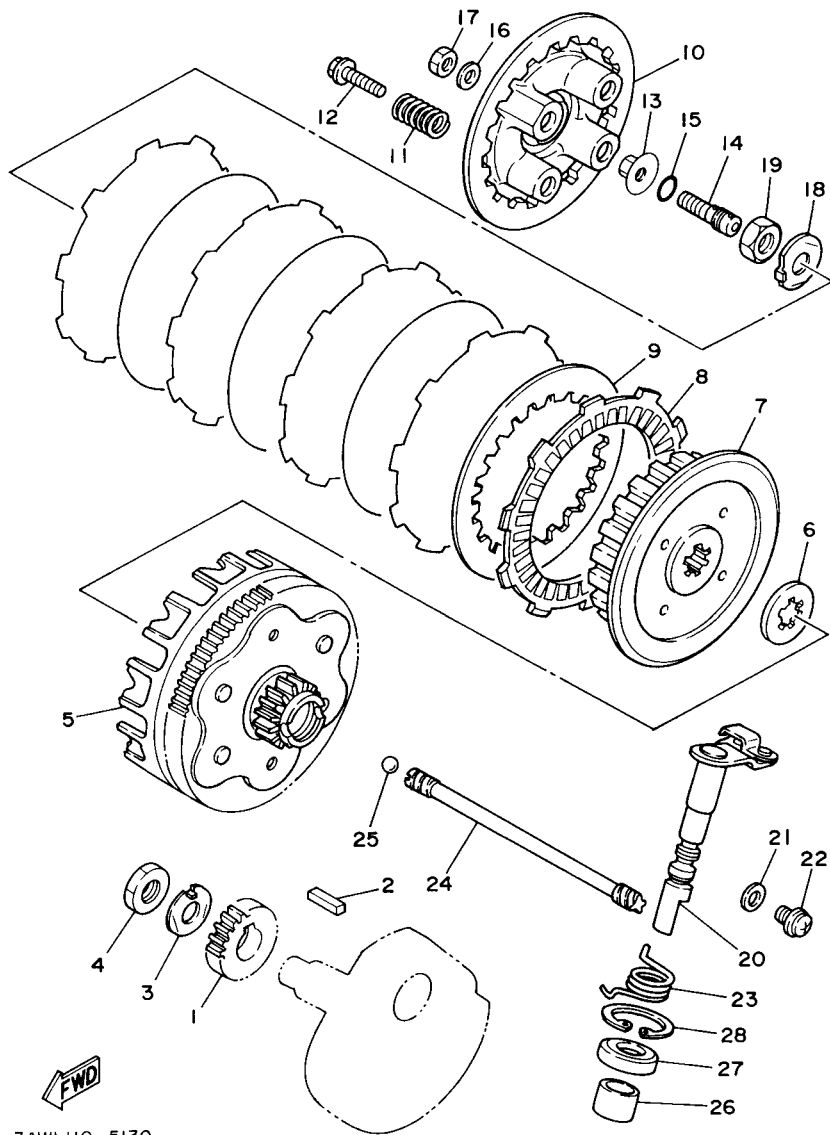

3AWL110-5130

FIG. 14 TRANSMISSION

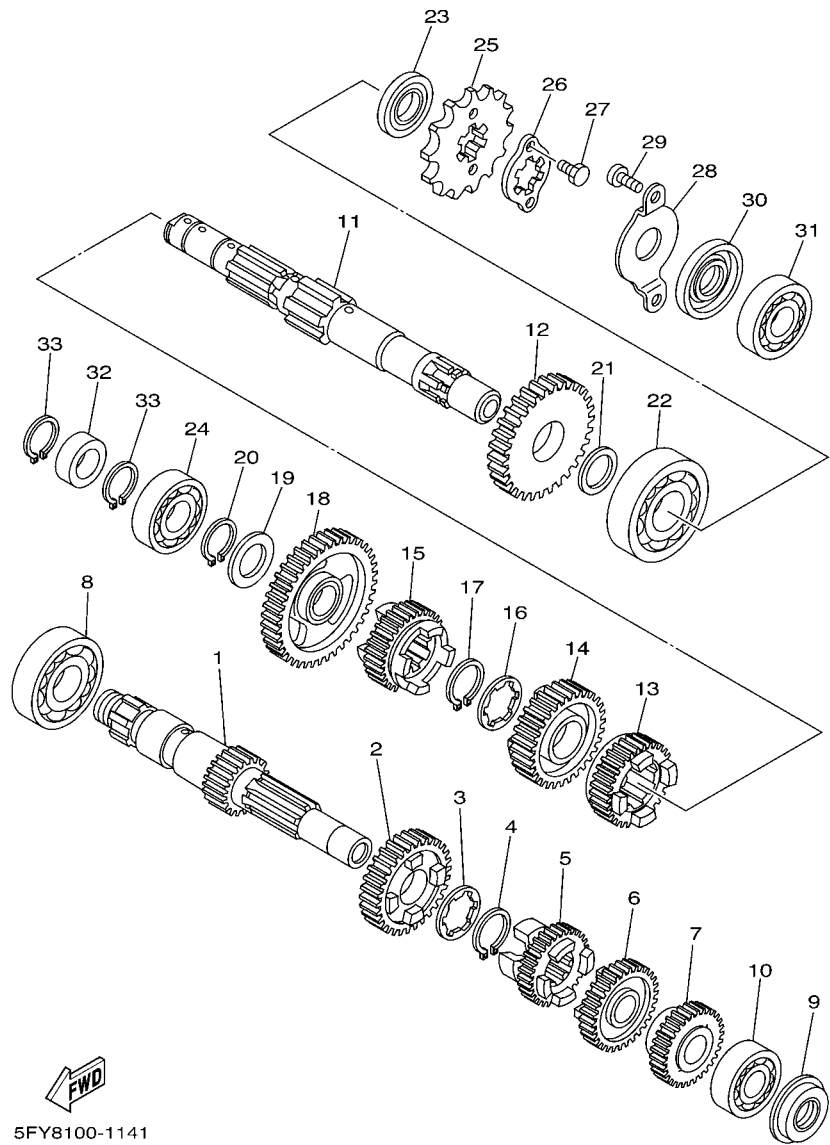

5FY8100-1141

REF. NO.	PART NO.	DESCRIPTION	5FYV	5FYW	5FYX	3XTG	5FYZ	REMARKS
1	15A-17411-01	AXLE, MAIN (12T)	1	1	1	1	1	
2	15A-17151-01	GEAR, 5TH PINION (28T)	1	1	1	1	1	
3	90209-16209	WASHER	1	1	1	1	1	
4	93410-20038	CIRCLIP	1	1	1	1	1	
5	5H0-17121-01	GEAR, 2ND PINION (22T)	1	1	1	1	1	
6	15A-17141-00	GEAR, 4TH PINION (25T)	1	1	1	1	1	
7	15A-17121-00	GEAR, 2ND PINION (19T)	1	1	1	1	1	
8	93306-20401	BEARING	1	1	1	1	1	
9	93101-15101	OIL SEAL	1	1	1	1	1	
10	93306-20201	BEARING	1	1	1	1	1	
11	2JX-17402-00	DRIVE AXLE ASSY	1	1	1	1	1	
12	15A-17221-00	GEAR, 2ND WHEEL (34T)	1	1	1	1	1	
13	15A-17241-00	GEAR, 4TH WHEEL (26T)	1	1	1	1	1	
14	15A-17231-00	GEAR, 3RD WHEEL (29T)	1	1	1	1	1	
15	1EV-17251-00	GEAR, 5TH WHEEL (23T)	1	1	1	1	1	
16	90209-18208	WASHER	1	1	1	1	1	
17	93410-22039	CIRCLIP	1	1	1	1	1	
18	15A-17211-01	GEAR, 1ST WHEEL (34T)	1	1	1	1	1	
19	90201-17257	WASHER, PLATE	1	1	1	1	1	
20	99009-17400	CIRCLIP	1	1	1	1	1	
21	90201-220J8	WASHER, PLATE	1	1	1	1	1	
22	93306-20580	BEARING	1	1	1	1	1	
23	93102-22389	OIL SEAL	1	1	1	1	1	
24	93306-20332	BEARING	1	1	1	1	1	
25	93823-14149	SPROCKET, DRIVE (14T)	1	1	1	1	1	
26	2JX-17456-00	HOLDER, SPROCKET	1	1	1	1	1	
27	97007-05010	BOLT	2	2	2	2	2	

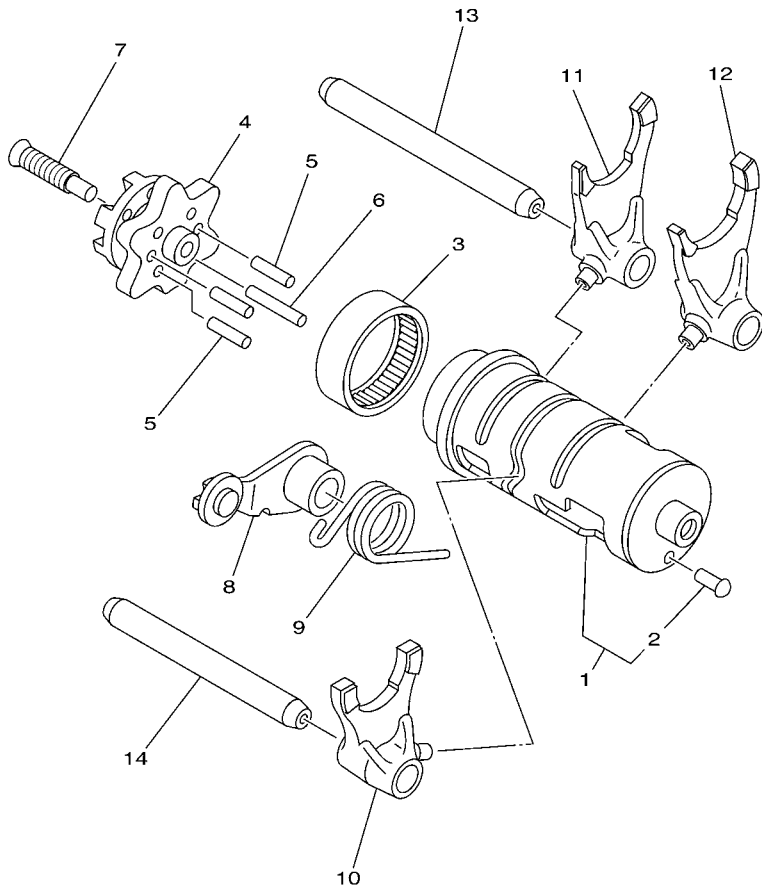

FIG. 15 SHIFT CAM & FORK

REF. NO.	PART NO.	DESCRIPTION	5FYV	5FYW	5FYX	3XTG	5FYV	REMARKS
1	5N0-18540-00	SHIFT CAM ASSY	1	1	1	1	1	
2	136-18542-00	.POINT, NEUTRAL	1	1	1	1	1	
3	93315-23607	BEARING	1	1	1	1	1	
4	1RH-18185-00	SEGMENT	1	1	1	1	1	
5	93604-16092	PIN, DOWEL	3	3	3	3	3	
6	93604-20156	PIN, DOWEL	1	1	1	1	1	
7	90151-06013	SCREW, COUNTERSUNK	1	1	1	1	1	
8	1RH-18140-00	STOPPER LEVER ASSY	1	1	1	1	1	
9	90508-26539	SPRING, TORSION	1	1	1	1	1	
10	4JG-18511-00	FORK, SHIFT 1	1	1	1	1	1	
11	4JG-18512-01	FORK, SHIFT 2	1	1	1	1	1	
12	4JG-18513-00	FORK, SHIFT 3	1	1	1	1	1	
13	3GX-18531-00	BAR, SHIFT FORK GUIDE 1	1	1	1	1	1	
14	3GX-18535-00	BAR, SHIFT FORK GUIDE 2	1	1	1	1	1	



5N0010-0170

FIG. 17 FRAME

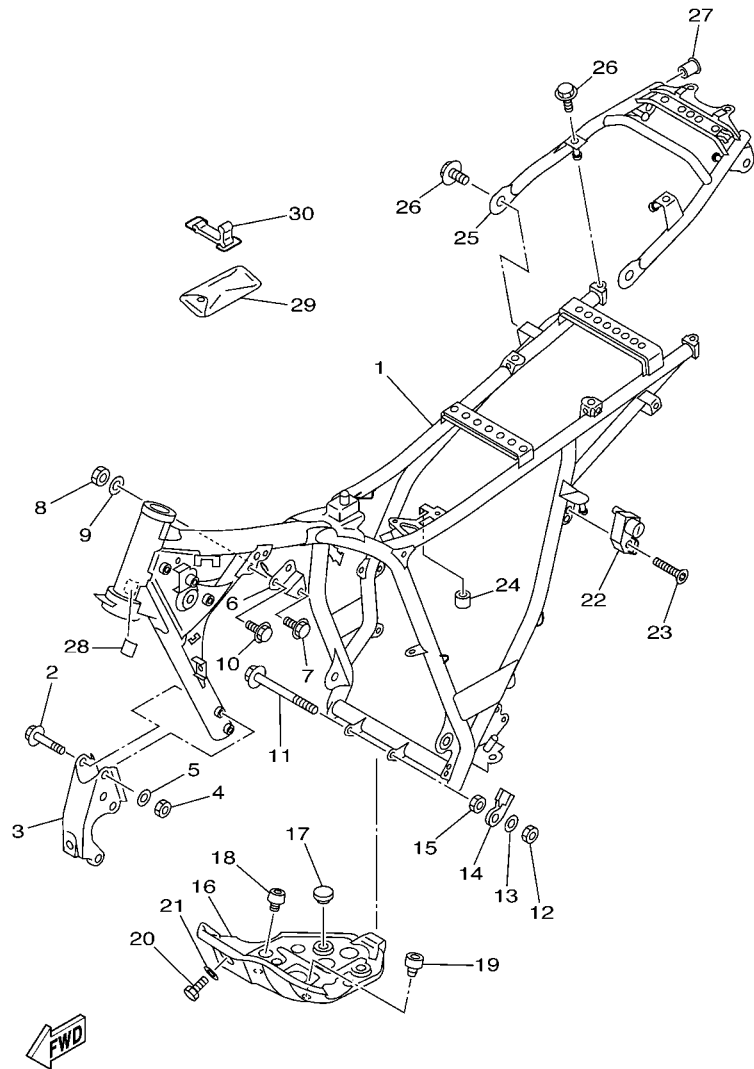

5FYG100-B170

REF. NO.	PART NO.	DESCRIPTION	5FYV	5FYW	5FYX	3XTG	5FYZ	REMARKS
1	5FY-21110-61	FRAME COMP.	1		1		1	
2	95817-08065	BOLT, FLANGE	4	4	4	4	4	
3	1RL-21316-00-P2	STAY, ENGINE 3	1		1	1	1	S8
4	90185-08089	NUT, SELF-LOCKING	4	4	4	4	4	
5	90201-08366	WASHER, PLATE	4	4	4	4	4	
6	5VC-21315-00	STAY, ENGINE 2	1	1	1	1	1	
7	95817-08050	BOLT, FLANGE	1	1	1	1	1	
8	90185-08089	NUT, SELF-LOCKING	1	1	1	1	1	
9	90201-08366	WASHER, PLATE	1	1	1	1	1	
10	90105-08066	BOLT, FLANGE	2	2	2	2	2	
11	95817-08120	BOLT, FLANGE	1	1	1	1	1	
12	90185-08089	NUT, SELF-LOCKING	1	1	1	1	1	
13	90201-08366	WASHER, PLATE	1	1	1	1	1	
14	1RL-21337-00	CLAMP, CABLE	1	1	1	1	1	
15	90185-08055	NUT, SELF-LOCKING	1	1	1	1	1	
16	1RL-21471-00-35	PROTECTOR, ENGINE	1	1	1	1	1	SL
17	128-27114-00	STOPPER, MAIN STAND	2	2	2	2	2	
18	34L-21485-00	DAMPER, RUBBER 1	1	1	1	1	1	
19	4N0-27114-00	STOPPER, MAIN STAND	1	1	1	1	1	
20	97007-06016	BOLT	1	1	1	1	1	
21	92907-06600	WASHER, PLATE	1	1	1	1	1	
22	4R8-21308-00	HELMET HANGER ASSY	1	1	1	1	1	
23	90151-06018	SCREW, COUNTERSUNK	1	1	1	1	1	
24	90480-12299	GROMMET	1	1	1	1	1	

FIG. 18 FENDER

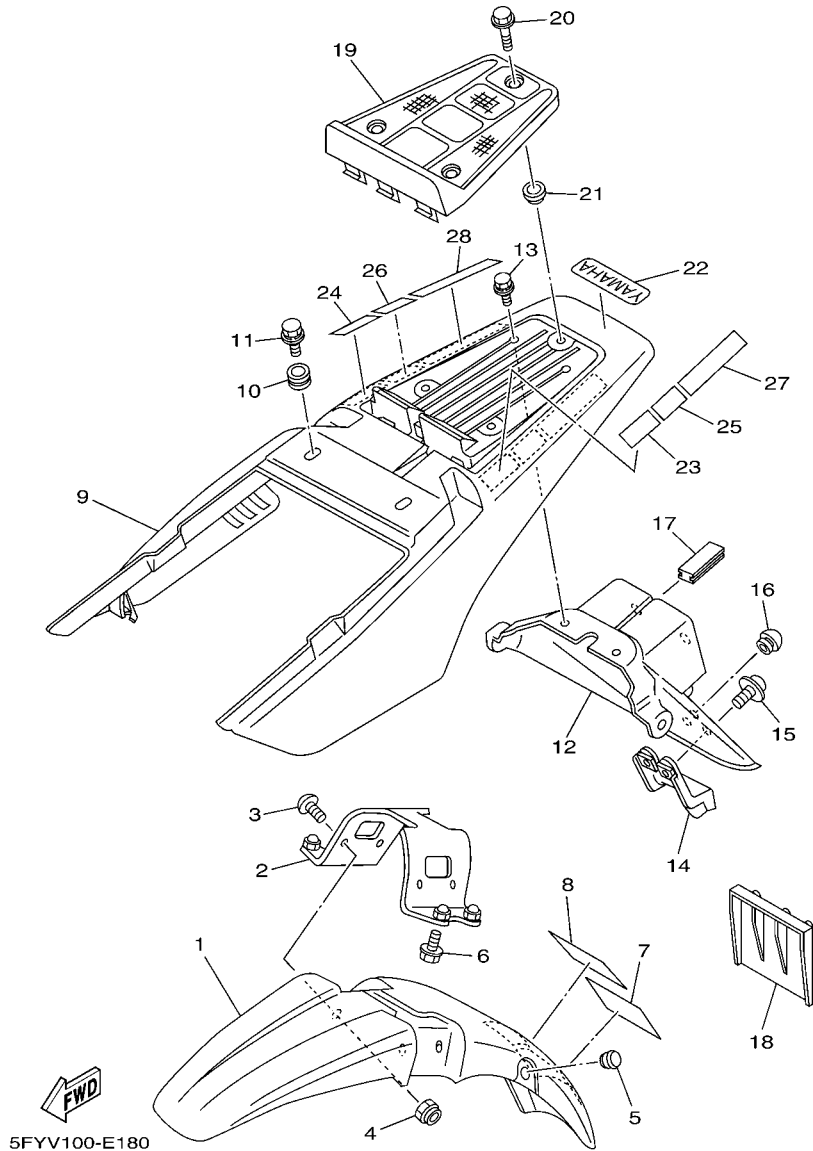

REF. NO.	PART NO.	DESCRIPTION	5FYV	5FYW	5FYX	3XTG	5FYV	REMARKS
1	2YG-21511-00	FENDER, FRONT	1	1	1	1	1	YB
2	2JX-21512-00	BRACKET, FENDER	1	1	1	1	1	
3	90154-05004	SCREW, BINDING	4	4	4	4	4	
4	95607-05200	NUT, U FLANGE	4	4	4	4	4	
5	90338-12192	PLUG	1	1	1	1	1	
6	95807-06020	BOLT, FLANGE	4	4	4	4	4	
7	3XT-21668-A0	LABEL, TIRE	1	1	1	1	1	
8	N/A							
9	2YG-21611-00	FENDER, REAR	1	1	1	1	1	YB
10	90480-12053	GROMMET	2	2	2	2	2	
11	90119-06063	BOLT, WITH WASHER	4	4	4	4	4	
12	2JX-21685-00	BRACKET, LICENSE	1	1	1	1	1	
13	90119-06056	BOLT, WITH WASHER	2	2	2	2	2	
14	2JX-21641-00	BRACKET, REFLECTOR	1	1	1	1	1	
15	90159-05028	SCREW, WITH WASHER	2	2	2	2	2	
16	4G0-21639-00	DAMPER 2	1	1	1		1	
17	2JX-21669-00	SEAL	1	1	1	1	1	
18	5VC-21691-00	FLAP	1	1	1	1	1	
19	2JX-21651-10	COVER, REAR FENDER	1	1	1	1	1	
20	95024-06014	BOLT, FLANGE	3	3	3	3	3	
21	90387-06681	COLLAR	3	3	3	3	3	
22	99247-00080	EMBLEM, YAMAHA	1	1	1	1	1	
23	N/A							
24	N/A							
25	N/A							
26	N/A							

FIG. 18 FENDER

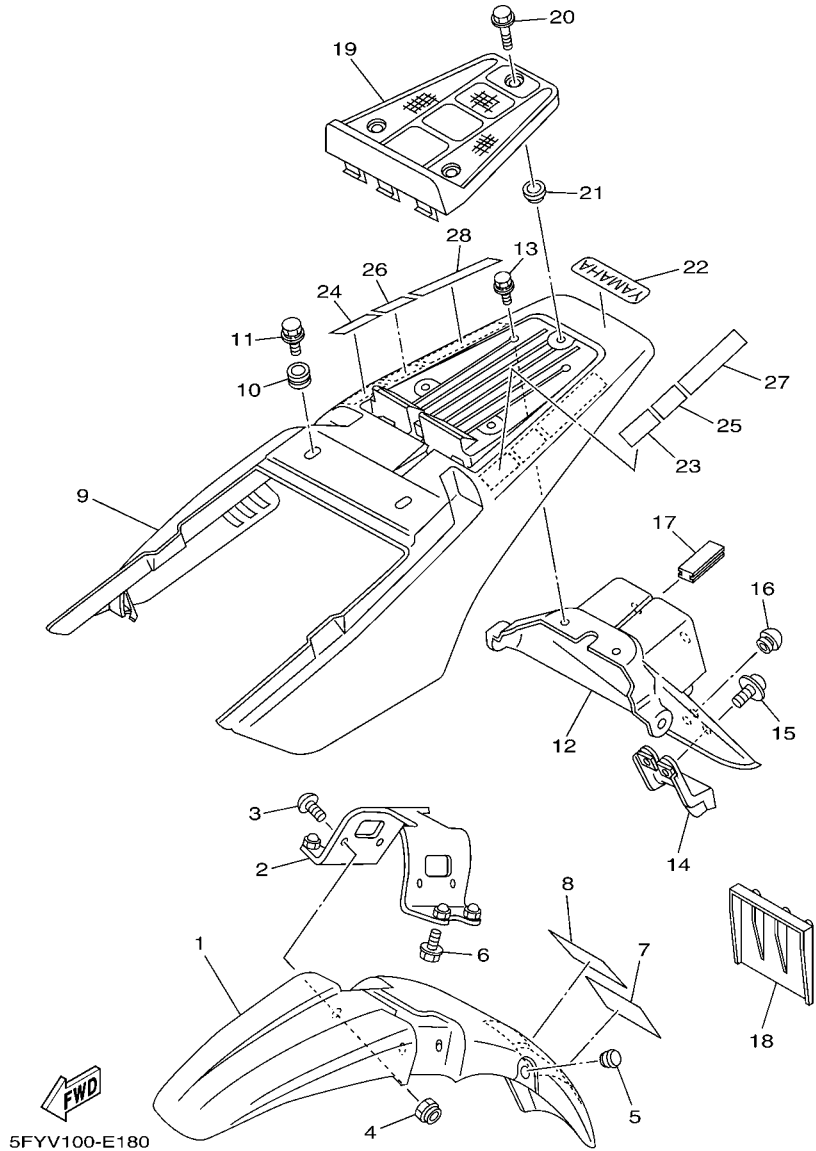

REF. NO.	PART NO.	DESCRIPTION	5FYV	5FYW	5FYX	3XTG	5FYV	REMARKS
27	N/A							
28	N/A							

FIG. 19 SIDE COVER

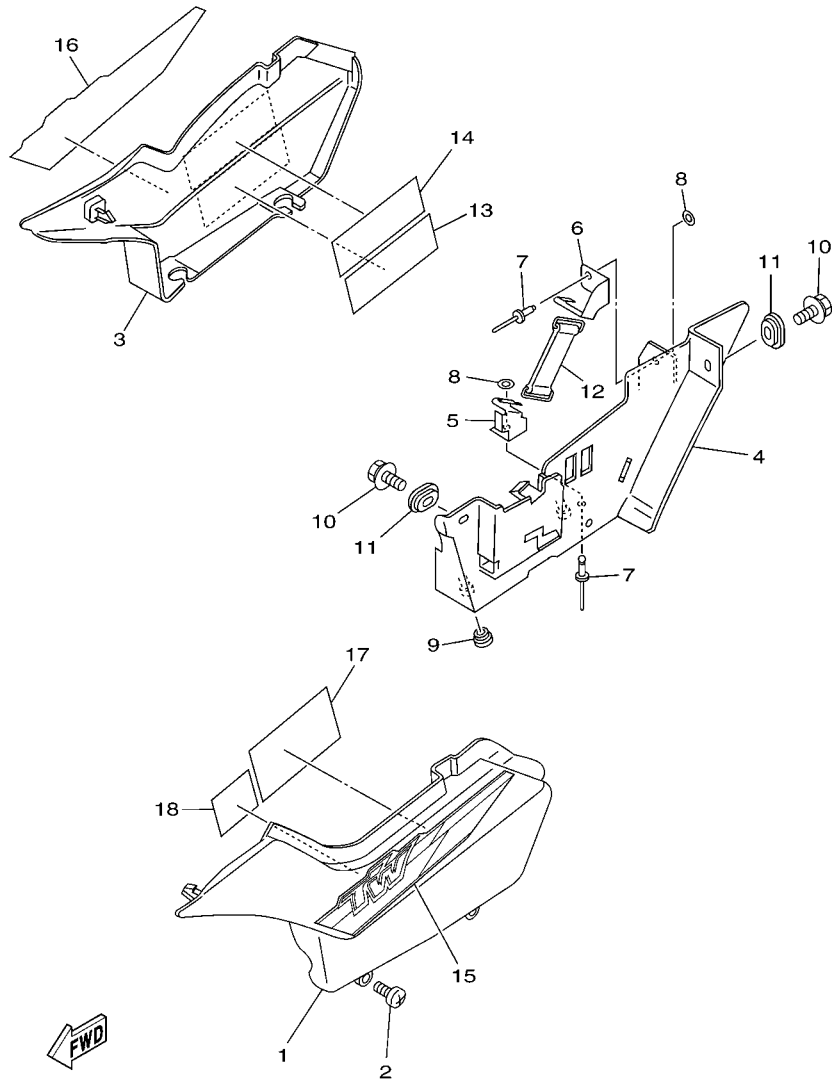

5FYV100-E190

REF. NO.	PART NO.	DESCRIPTION	5FYV	5FYW	5FYX	3XTG	5FYV	REMARKS
1	2YG-21711-00-0X	COVER, SIDE 1	1	1	1	1	1	LGB
2	90154-05013	SCREW, BINDING	2	2	2	2	2	
3	2YG-21721-00-0X	COVER, SIDE 2	1	1	1	1	1	LGB
4	5EK-2177A-00	BOX	1	1	1	1	1	
5	5EK-2175T-00	BRACKET 1	1	1	1	1	1	
6	5EK-2175U-00	BRACKET 2	1	1	1	1	1	
7	90267-40075	RIVET, BLIND	2	2	2	2	2	
8	90201-04018	WASHER, PLATE	2	2	2	2	2	
9	90480-13197	GROMMET	2	2	2	2	2	
10	90119-06056	BOLT, WITH WASHER	2	2	2	2	2	
11	90480-01141	GROMMET	2	2	2	2	2	
12	116-82131-00	BAND, BATTERY	1	1	1	1	1	
13	N/A							
14	N/A							
15	5FY-2173E-60	GRAPHIC 1	1	1	1	1	1	
16	5FY-2173F-60	GRAPHIC 2	1	1	1	1	1	
17	N/A							
18	N/A							

FIG. 20 REAR ARM

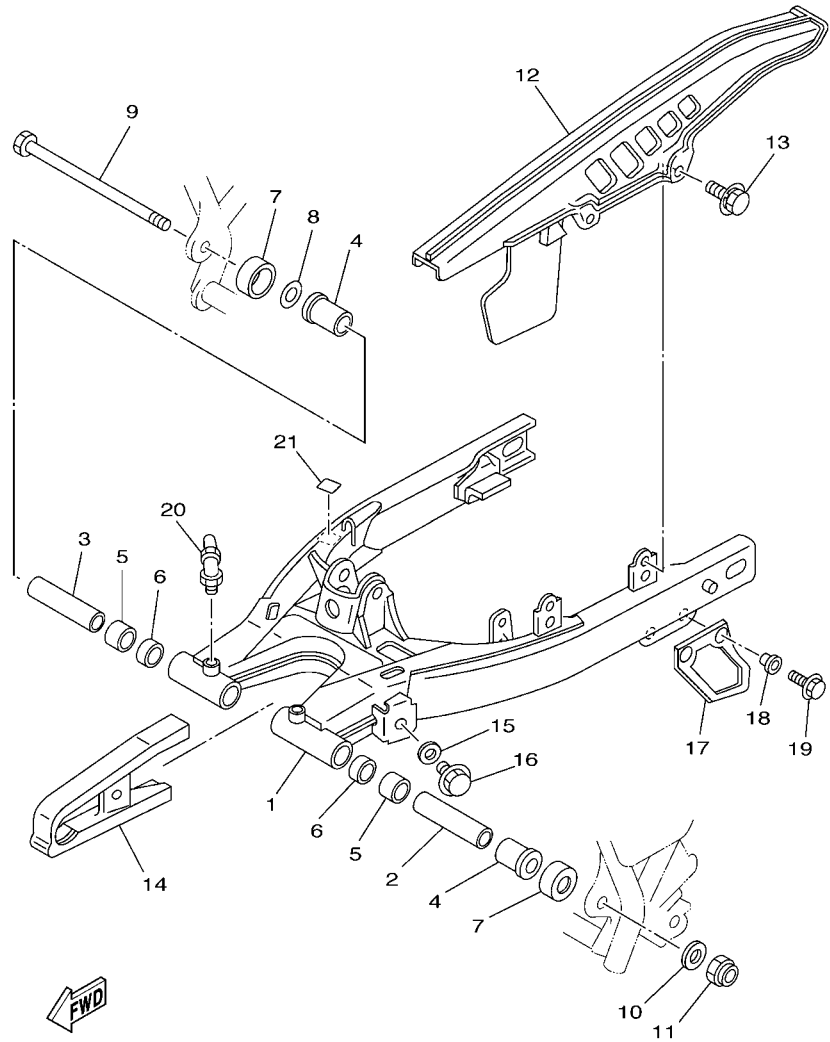

5FYG100-B200

REF. NO.	PART NO.	DESCRIPTION	5FYV	5FYW	5FYX	3XTG	5FYZ	REMARKS
1	2JX-22110-00-35	REAR ARM COMP.	1	1	1	1	1	SL
2	2JX-22123-00	BUSH 1	1	1	1	1	1	
3	2JX-22124-00	BUSH 2	1	1	1	1	1	
4	90386-18146	BUSH	2	2	2	2	2	
5	90380-18139	BUSH, SOLID	2	2	2	2	2	
6	93109-18020	OIL SEAL	2	2	2	2	2	
7	401-22128-01	COVER, THRUST 1	2	2	2	2	2	
8	401-22127-00	SHIM	1	1	1	1	1	
9	2JX-22141-00	SHAFT, PIVOT	1	1	1	1	1	
10	90201-120E8	WASHER, PLATE	1	1	1	1	1	
11	90185-12134	NUT, SELF-LOCKING	1	1	1	1	1	
12	34X-22311-00	CASE, CHAIN	1	1	1	1	1	
13	90119-05059	BOLT, WITH WASHER	2	2	2	2	2	
14	34X-22151-01	SEAL, GUARD	1	1	1	1	1	
15	90209-06187	WASHER	1	1	1	1	1	
16	90119-05062	BOLT, WITH WASHER	1	1	1	1	1	
17	5BT-22199-00	SUPPORT, CHAIN	1	1	1	1	1	
18	90387-06737	COLLAR	2	2	2	2	2	
19	95807-06020	BOLT, FLANGE	2	2	2	2	2	
20	93700-06009	NIPPLE, GREASE	2	2	2	2	2	
21	3MA-27491-00	PROTECTOR	1	1	1	1	1	

FIG. 21 REAR SUSPENSION

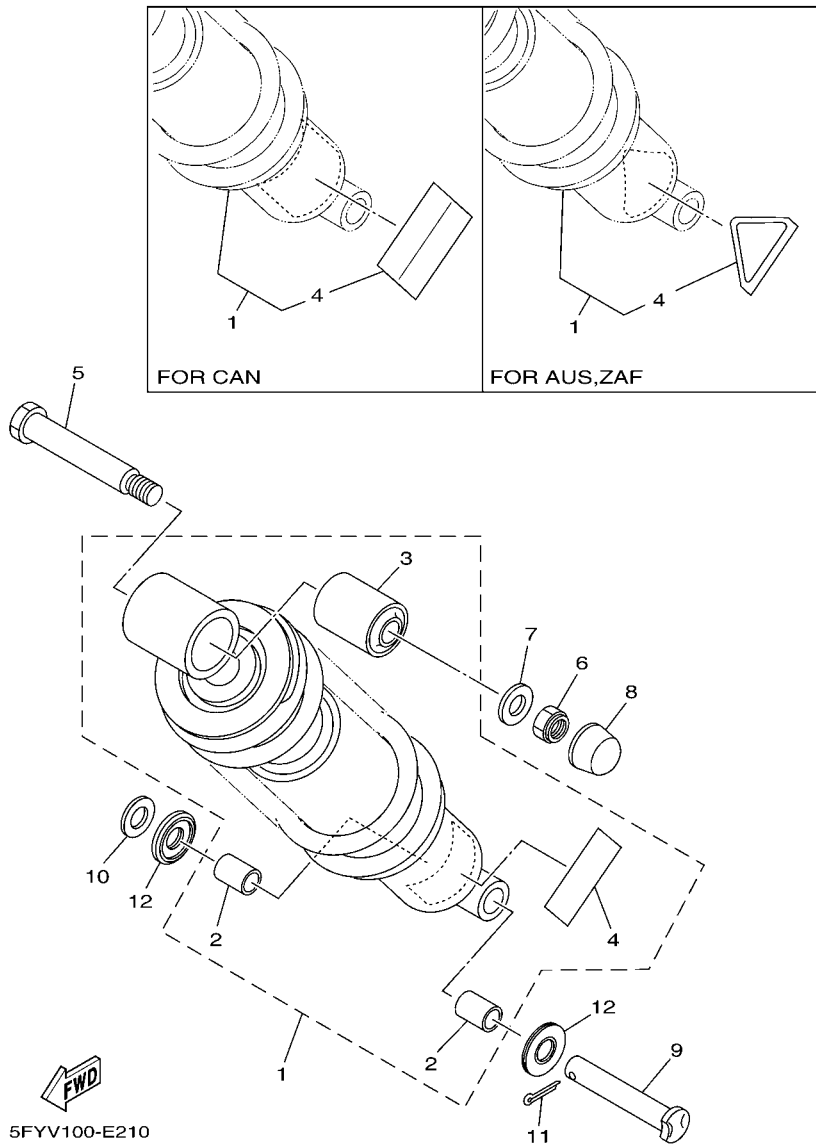

REF. NO.	PART NO.	DESCRIPTION	5FYV	5FYW	5FYX	3XTG	5FYV	REMARKS
1	5FY-22210-20-P0	SHOCK ABSORBER ASSY, REAR					1	LRY51
2	90380-12051	.BUSH, SOLID	2	2	2	2	2	
3	1M1-22216-00	.BUSH, REAR SHOCK ABSORBER	1	1	1	1	1	
4	4AA-22259-40	.LABEL, WARNING					1	
5	90109-100E2	BOLT	1	1	1	1	1	
6	95617-10100	NUT, U	1	1	1	1	1	
7	90201-100E9	WASHER, PLATE	1	1	1	1	1	
8	50W-25188-00	CAP	1	1	1	1	1	
9	90240-12075	PIN, CLEVIS	1	1	1	1	1	
10	90201-12749	WASHER, PLATE	1	1	1	1	1	
11	91401-30025	PIN, SPLIT	1	1	1	1	1	
12	30X-22129-00	COVER, THRUST 2	2	2	2	2	2	

FIG. 22 STEERING

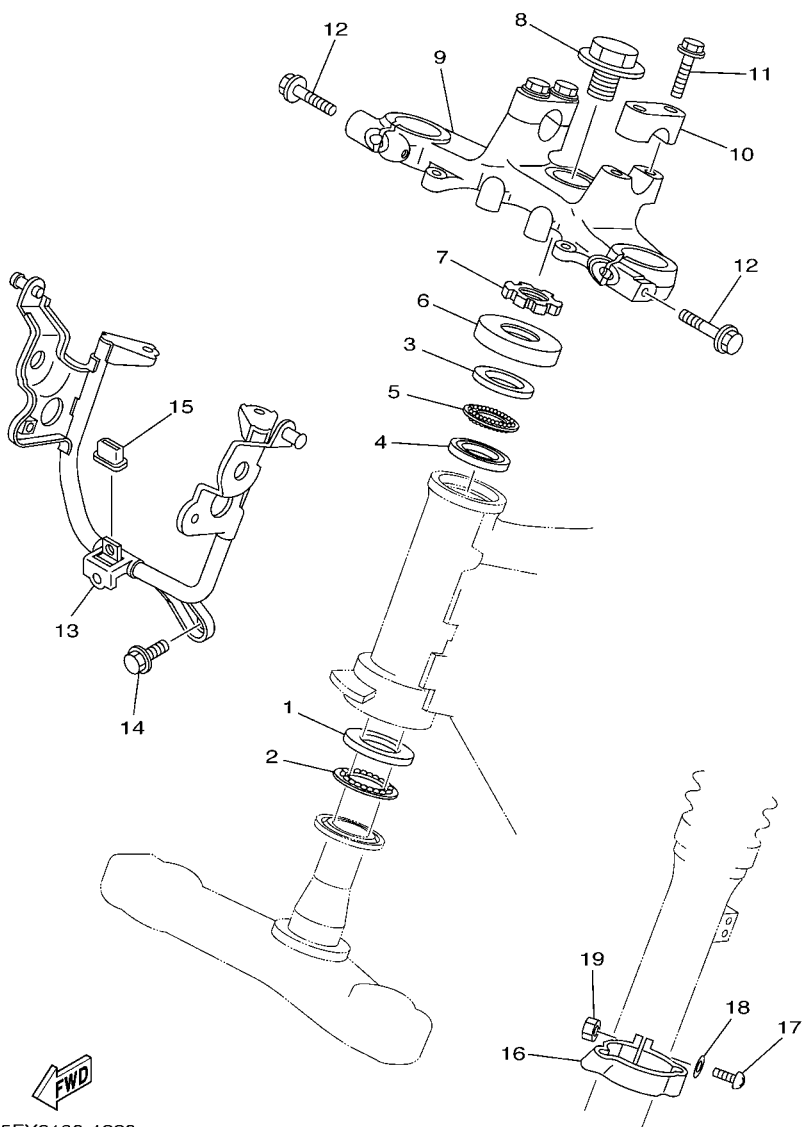

5FY8100-1220

REF. NO.	PART NO.	DESCRIPTION	5FY	5FYW	5FYX	3XTG	5FY	REMARKS
1	156-23412-00	RACE, BALL 2	1	1	1	1	1	
2	156-2341E-00	RETAINER, BALL BEARING	1	1	1	1	1	
3	22F-23411-01	RACE, BALL 1	1	1	1	1	1	
4	22F-23412-01	RACE, BALL 2	1	1	1	1	1	
5	22F-2341E-00	RETAINER, BALL BEARING	1	1	1	1	1	
6	36X-23416-00	COVER, BALL RACE 2	1	1	1	1	1	
7	90179-25033	NUT	1	1	1	1	1	
8	90105-14102	BOLT, FLANGE	1	1	1	1	1	
9	2JX-23435-00-35	CROWN, HANDLE	1	1	1	1	1	SL
10	1E6-23441-10-35	HOLDER, HANDLE UPPER	2	2	2	2	2	SL
11	95824-08035	BOLT, FLANGE	4	4	4	4	4	
12	95024-08050	BOLT, FLANGE	2	2	2	2	2	
13	5FY-23174-00	STAY, HEADLIGHT	1	1	1	1	1	
14	95807-06012	BOLT, FLANGE	1	1	1	1	1	
15	30X-23445-00	DAMPER	1	1	1	1	1	
16	34X-23317-00	HOLDER, CABLE	1	1	1	1	1	
17	98507-05018	SCREW, PAN HEAD	1	1	1	1	1	
18	92907-05600	WASHER, PLATE	1	1	1	1	1	
19	95307-05600	NUT	1	1	1	1	1	

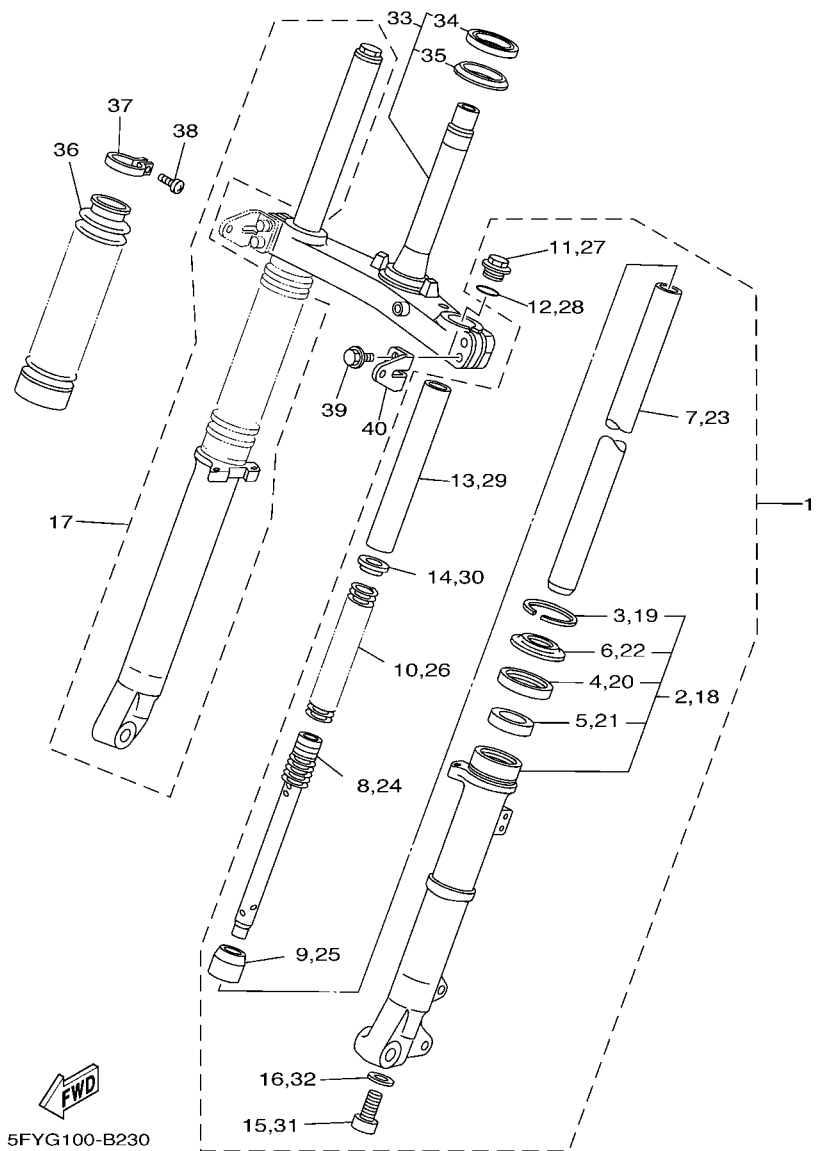
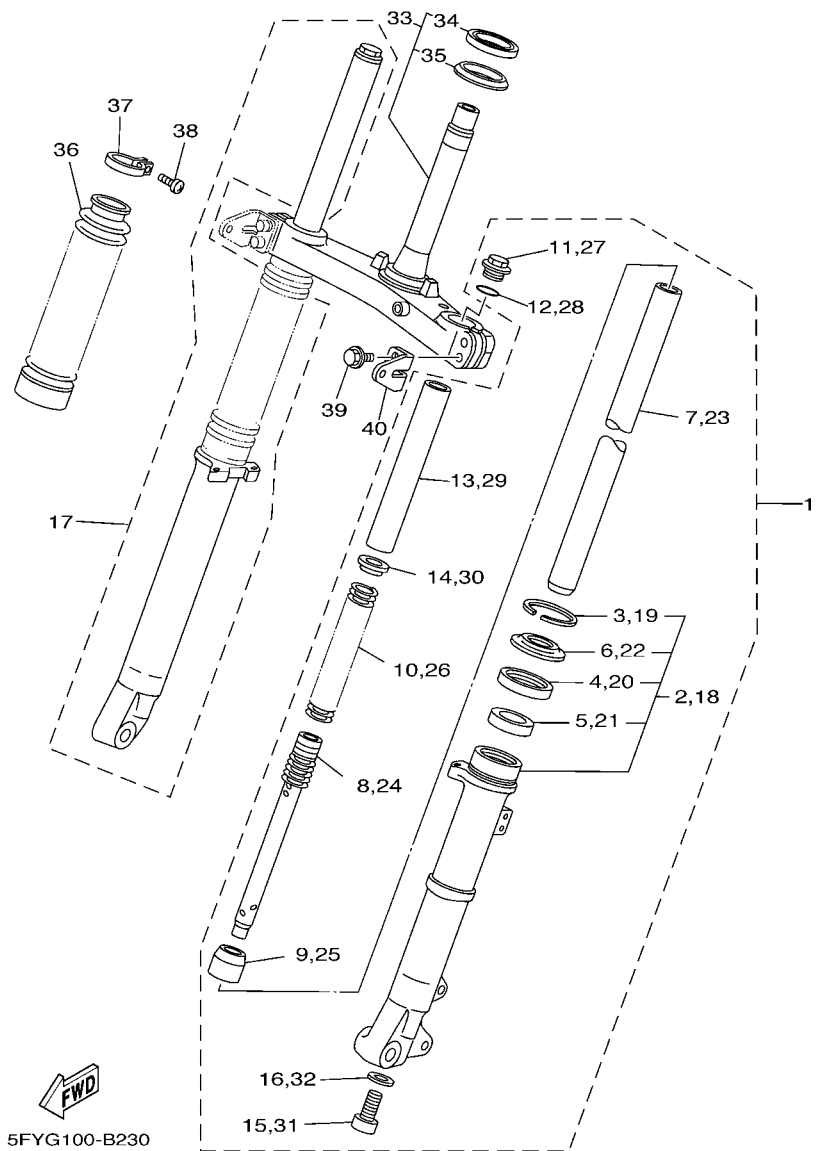

FIG. 23 FRONT FORK

REF. NO.	PART NO.	DESCRIPTION	5FYV	5FYW	5FYX	3XTG	5FYV	REMARKS
1	5FY-23102-20	FRONT FORK ASSY (L.H)	1	1	1		1	
2	5RS-23126-10	.TUBE, OUTER (LEFT)	1	1	1		1	
3	22W-23153-L0	..RING, SNAP	1	1	1	1	1	
4	22W-23145-L0	..OIL SEAL	1	1	1	1	1	
5	51Y-23125-00	..METAL, SLIDE 1	1	1	1	1	1	
6	54G-23144-00	..SEAL, DUST	1	1	1	1	1	
7	2JX-23110-00	.INNER TUBE COMP.1	1	1	1	1	1	
8	2JX-23170-00	.CYLINDER COMP., FRONT FORK	1	1	1	1	1	
9	3R6-23173-L0	.SPINDLE, TAPER	1	1	1	1	1	
10	2JX-23141-00	.SPRING, FRONT FORK	1	1	1		1	
11	2JN-23111-00	.BOLT, CAP	1	1	1	1	1	
12	3J2-23114-00	.O-RING	1	1	1	1	1	
13	22U-23118-01	.SPACER	1	1	1		1	
14	3DM-23149-10	.WASHER, SPRING UPPER	1	1	1	1	1	
15	278-23181-50	.BOLT, HEXAGON SOCKET HEAD	1	1	1	1	1	
16	509-23158-L0	.GASKET	1	1	1	1	1	
17	5FY-23103-20	FRONT FORK ASSY (R.H)	1	1	1		1	
18	5RS-23136-10	.TUBE, OUTER (RIGHT)	1	1	1		1	
19	22W-23153-L0	..RING, SNAP	1	1	1	1	1	
20	22W-23145-L0	..OIL SEAL	1	1	1	1	1	
21	51Y-23125-00	..METAL, SLIDE 1	1	1	1	1	1	

FIG. 23 FRONT FORK



5FYG100-B230

REF. NO.	PART NO.	DESCRIPTION	5FYV	5FYW	5FYX	3XTG	5FYV	REMARKS
22	54G-23144-00	..SEAL, DUST	1	1	1	1	1	
23	2JX-23110-00	.INNER TUBE COMP.1	1	1	1	1	1	
24	2JX-23170-00	.CYLINDER COMP., FRONT FORK	1	1	1	1	1	
25	3R6-23173-L0	.SPINDLE, TAPER	1	1	1	1	1	
26	2JX-23141-00	.SPRING, FRONT FORK	1	1	1		1	
27	2JN-23111-00	.BOLT, CAP	1	1	1	1	1	
28	3J2-23114-00	.O-RING	1	1	1	1	1	
29	22U-23118-01	.SPACER	1	1	1		1	
30	3DM-23149-10	.WASHER, SPRING UPPER	1	1	1	1	1	
31	278-23181-50	.BOLT, HEXAGON SOCKET HEAD	1	1	1	1	1	
32	509-23158-L0	.GASKET	1	1	1	1	1	
33	5LB-23340-00	UNDER BRACKET COMP.	1	1	1	1	1	
34	156-23411-00	.RACE, BALL 1	1	1	1	1	1	
35	164-23462-00	.SEAL, STEERING	1	1	1	1	1	
36	4CS-23191-20	BOOT	2	2	2	2	2	
37	2K5-23192-00	BAND	2	2	2	2	2	
38	1W4-23194-L0	SCREW, BOOT BAND	2	2	2	2	2	
39	5RS-23346-00	BOLT 1	4	4	4	4	4	
40	49R-85112-00	BRACKET, REFLECTOR 1	2	2	2		2	

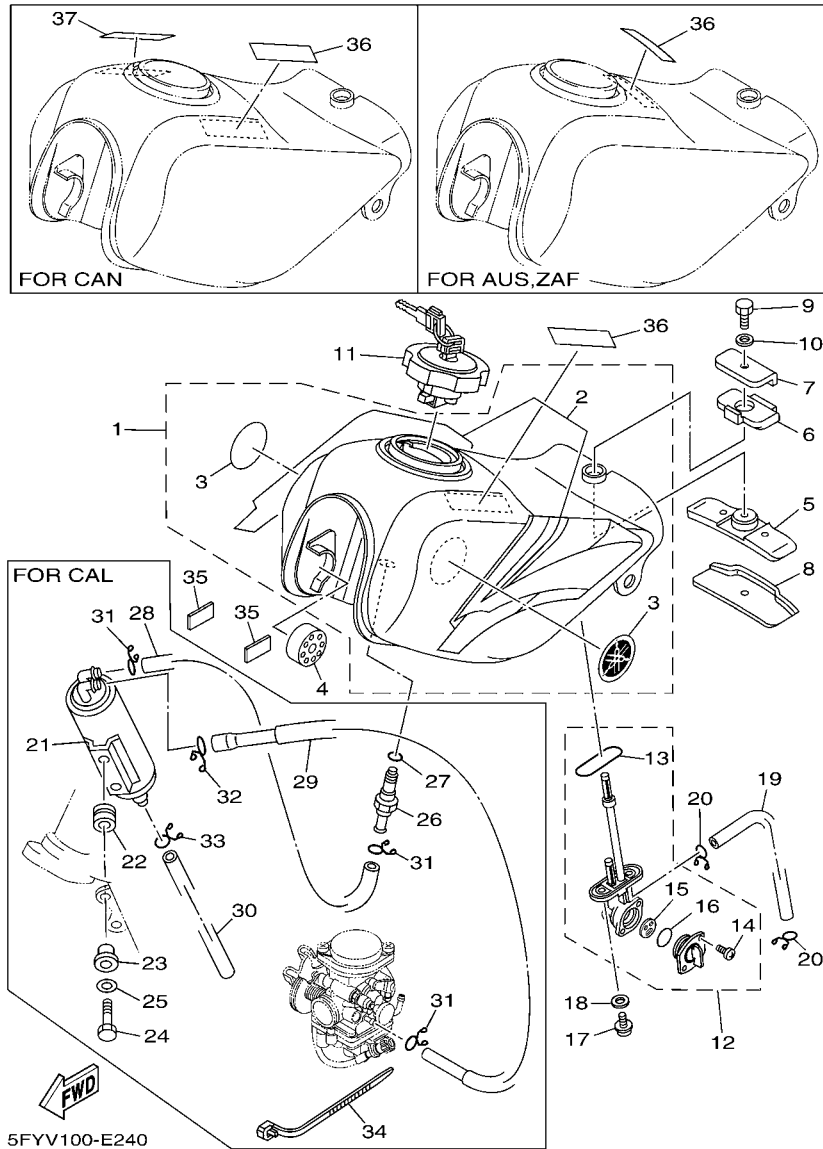
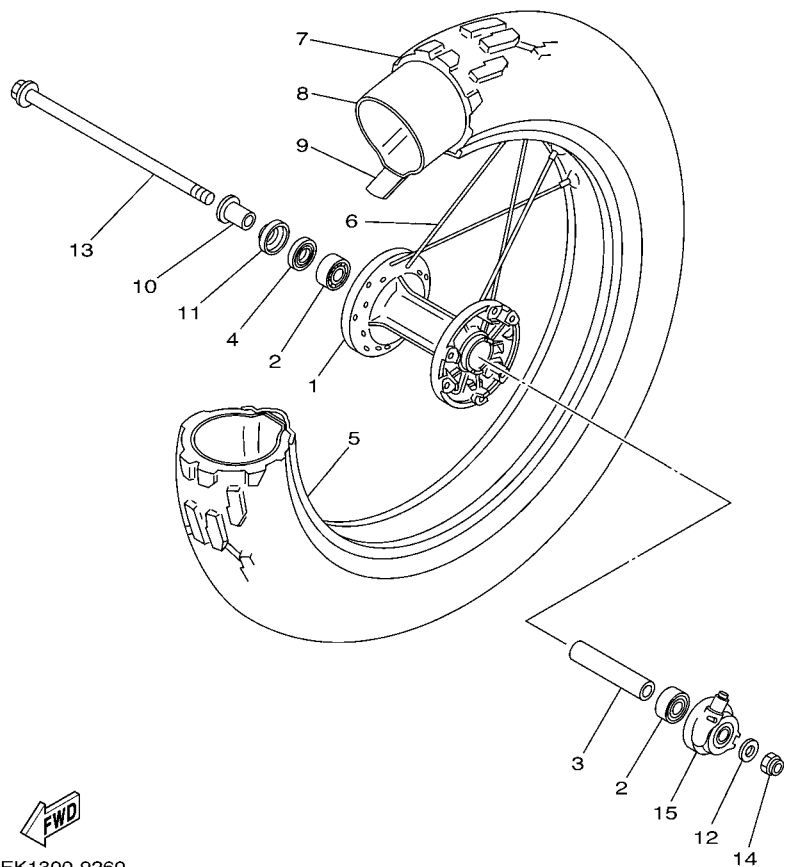

FIG. 24 FUEL TANK

REF. NO.	PART NO.	DESCRIPTION	5FYV	5FYW	5FYX	3XTG	5FYV	REMARKS
1	5RS-Y2410-10-07	FUEL TANK COMP.	1		1	1	1	DPBMC
2	5FY-24240-60	.GRAPHIC SET	1	1	1	1	1	
3	5VX-2411B-00	.TUNING FORK MARK	2	2	2	2	2	
4	4L0-24181-00	DAMPER, LOCATING 1	2	2	2	2	2	
5	30X-24182-01	DAMPER, LOCATING 2	1	1	1	1	1	
6	30X-24183-01	DAMPER, LOCATING 3	1	1	1	1	1	
7	30X-24186-01	WASHER, SPECIAL	1	1	1	1	1	
8	30X-24187-00	WASHER, SPECIAL	1	1	1	1	1	
9	97007-06012	BOLT	1	1	1	1	1	
10	92907-06600	WASHER, PLATE	1	1	1	1	1	
11	11H-24602-03	CAP ASSY	1		1	1	1	
12	23F-24500-11	FUEL COCK ASSY 1	1	1	1	1	1	
13	4X8-24512-00	.O-RING	1	1	1	1	1	
14	98507-03008	.SCREW, PAN HEAD	2	2	2	2	2	
15	3AC-24523-00	.VALVE PACKING	1	1	1	1	1	
16	3AJ-24534-01	.SEAL, COCK	1	1	1	1	1	
17	90149-06011	SCREW	2	2	2	2	2	
18	90202-05193	WASHER, PLATE	2	2	2	2	2	
19	90445-10007	HOSE (L110)	1	1	1	1	1	
20	90467-09006	CLIP	2	2	2	2	2	

FIG. 26 FRONT WHEEL



5EK1300-9260

REF. NO.	PART NO.	DESCRIPTION	5FYV	5FYW	5FYX	3XTG	5FYV	REMARKS
1	5EK-25111-00	HUB, FRONT	1	1	1	1	1	
2	93306-20203	BEARING	2	2	2	2	2	
3	90560-15312	SPACER	1	1	1	1	1	
4	93102-20281	OIL SEAL (SD 20-35-5)	1	1	1	1	1	
5	94425-18603	RIM (2.50-18)	1	1	1	1	1	
6	4TP-25304-10	SPOKE SET	1	1	1	1	1	
7	L.M.	TIRE (130/80-18 M/C 66P TW31)					1	
8	L.M.	TUBE (130/80-18 M/C TR4)					1	
9	94340-18086	BAND, RIM (2.50-18)	1	1	1	1	1	
10	90387-15600	COLLAR	1	1	1	1	1	
11	322-25118-00	COVER, HUB DUST	1	1	1	1	1	
12	90201-14740	WASHER, PLATE	1	1	1	1	1	
13	2JX-25181-10	AXLE, WHEEL	1	1	1	1	1	
14	95607-14100	NUT, U	1	1	1	1	1	
15	5EK-25190-00	GEAR UNIT ASSY	1	1	1	1	1	

FIG. 27 FRONT BRAKE CALIPER

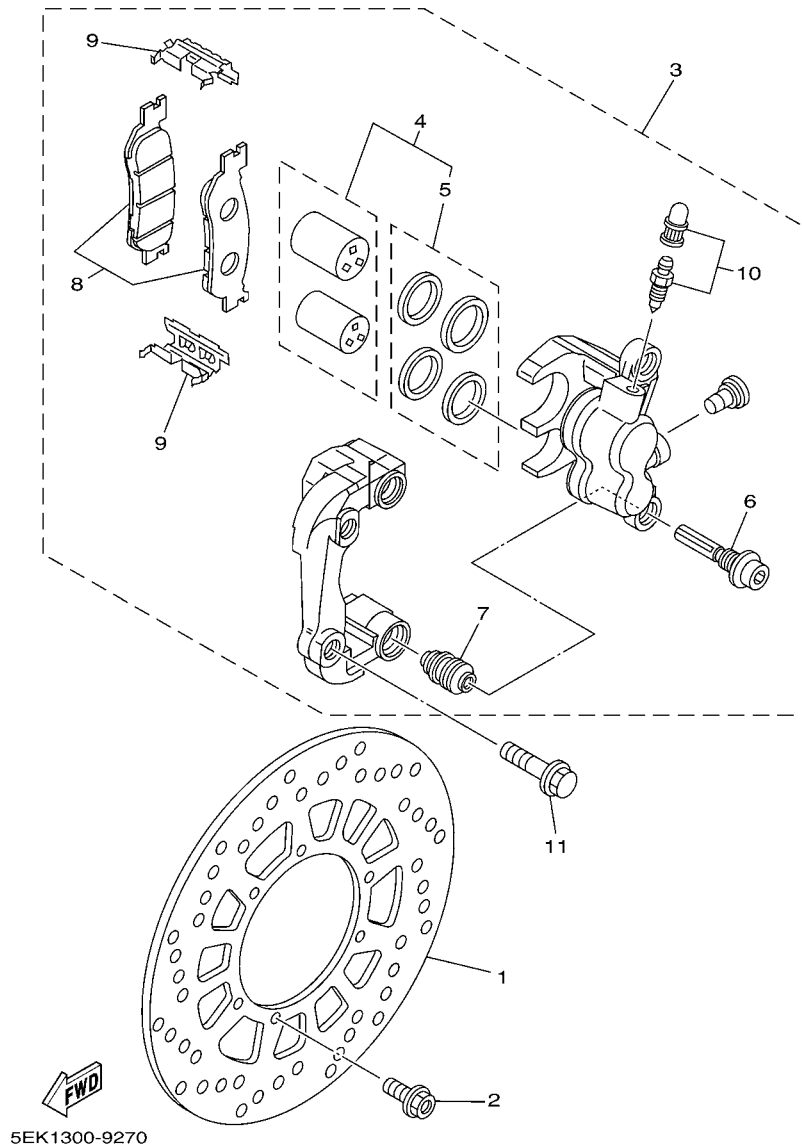

REF. NO.	PART NO.	DESCRIPTION	5FYV	5FYW	5FYX	3XTG	5FYV	REMARKS
1	5XT-2582T-00	DISC, BRAKE (LEFT)	1	1	1	1	1	
2	90109-065G4	BOLT	6	6	6	6	6	
3	5LB-2580T-01	CALIPER ASSY (LEFT)	1	1	1	1	1	
4	4JG-W0057-00	.PISTON ASSY, CALIPER	1	1	1	1	1	
5	4JG-W0047-00	..CALIPER SEAL KIT	1	1	1	1	1	
6	5JW-25914-10	.PIN, SLIDE	2	2	2	2	2	
7	4TT-25937-00	.BOOT 2	2	2	2	2	2	
8	5LB-W0045-01	.BRAKE PAD KIT	1	1	1	1	1	
9	4TT-25919-00	.SUPPORT, PAD	2	2	2	2	2	
10	51L-W0048-00	.BLEED SCREW KIT	1	1	1	1	1	
11	90105-10638	BOLT, FLANGE	2	2	2	2	2	

FIG. 28 REAR WHEEL

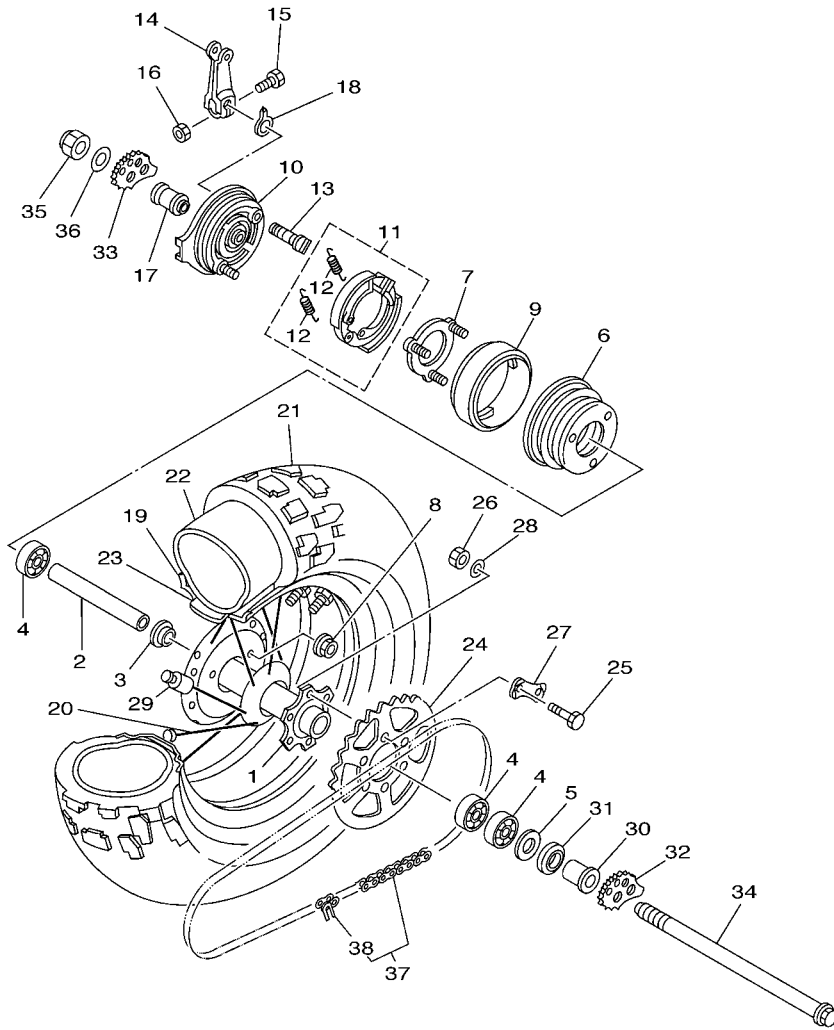

5FY8100-1280

REF. NO.	PART NO.	DESCRIPTION	5FY	5FYW	5FYX	3XTG	5FY	REMARKS
1	2JX-25311-00	HUB, REAR	1	1	1	1	1	
2	90560-17305	SPACER	1	1	1	1	1	
3	152-25115-00	FLANGE, SPACER 1	1	1	1	1	1	
4	93306-20348	BEARING	3	3	3	3	3	
5	93102-25311	OIL SEAL (FPJ 25-44-8 TS)	1	1	1	1	1	
6	5V7-2511E-00-35	DRUM, BRAKE	1	1	1	1	1	SL
7	54G-25185-00	RING 1	1	1	1	1	1	
8	90179-08410	NUT	3	3	3	3	3	
9	2JX-25336-00	RING 2	1	1	1	1	1	
10	2JX-25321-02-35	PLATE, BRAKE SHOE	1	1	1	1	1	SL
11	4KN-W253E-11	BRAKE SHOE KIT	1	1	1	1	1	
12	90506-15260	.SPRING, TENSION	2	2	2	2	2	
13	3Y6-25351-00	CAMSHAFT	1	1	1	1	1	
14	2N3-25155-00	LEVER, CAMSHAFT 1	1	1	1	1	1	
15	90101-06278	BOLT	1	1	1	1	1	
16	95307-06600	NUT	1	1	1	1	1	
17	90387-171T1	COLLAR	1	1	1	1	1	
18	2JX-2533A-00	PLATE, INDICATOR	1	1	1	1	1	
19	94445-14479	RIM (4.50-14)	1	1	1	1	1	
20	2JX-25304-21	SPOKE SET, REAR	1	1	1	1	1	
21	L.M.	TIRE (180/80-14 M/C 78P TW34)					1	
22	L.M.	TUBE (180/80-14 M/C TR4)					1	
23	94318-14149	BAND, RIM (4.50-14)	1	1	1	1	1	
24	15A-25450-20	SPROCKET, DRIVEN (50T)	1	1	1		1	
25	90109-08618	BOLT	6	6	6	6	6	
26	90185-08089	NUT, SELF-LOCKING	6	6	6	6	6	

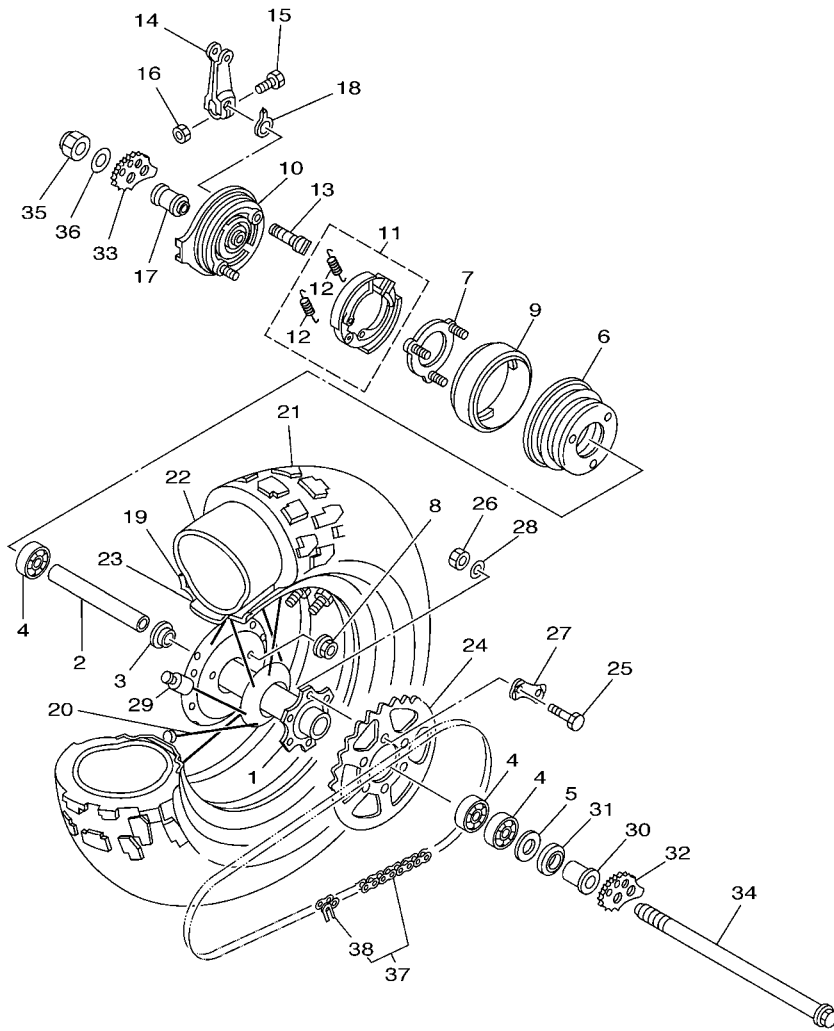

5FY8100-1280

FIG. 28 REAR WHEEL

REF. NO.	PART NO.	DESCRIPTION	5FYV	5FYW	5FYX	3XTG	5FYZ	REMARKS
27	90215-08160	WASHER, LOCK	3	3	3	3	3	
28	90201-086P8	WASHER, PLATE	6	6	6	6	6	
29	3HT-25398-00	BALANCER, WHEEL (15G)	1	1	1	1	1	UN
30	90387-171T2	COLLAR	1	1	1	1	1	
31	36R-25367-00	COVER, HUB DUST	1	1	1	1	1	
32	3Y1-25388-01	PULLER, CHAIN 1	1	1	1	1	1	
33	3Y1-25389-00	PULLER, CHAIN 2	1	1	1	1	1	
34	2JX-25381-10	AXLE, WHEEL	1	1	1	1	1	
35	90185-16127	NUT, SELF-LOCKING	1	1	1	1	1	
36	90201-164H4	WASHER, PLATE	1	1	1	1	1	
37	94580-88122	CHAIN (DID 428HG-122L)	1	1	1		1	
38	94680-88001	JOINT, CHAIN (DID 428HG)	1	1	1	1	1	

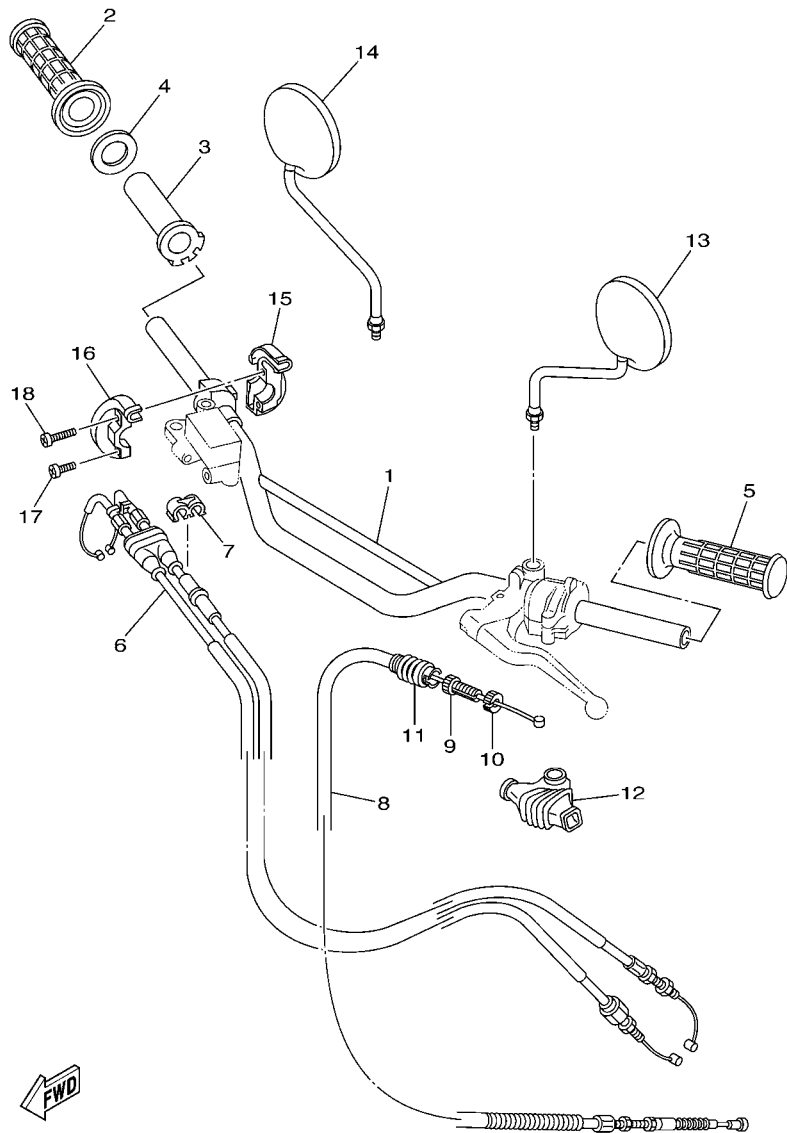

5FYG100-B290

FIG. 29 STEERING HANDLE & CABLE

REF. NO.	PART NO.	DESCRIPTION	5FYV	5FYW	5FYX	3XTG	5FYV	REMARKS
1	5LB-26111-00	HANDLEBAR	1	1	1	1	1	
2	1LX-26242-01	GRIP (RIGHT)	1	1	1	1	1	
3	5BE-26243-00	TUBE, THROTTLE GUIDE	1	1	1	1	1	
4	3Y1-26249-00	RING, LEAF	1	1	1	1	1	
5	1LX-26241-01	GRIP (LEFT)	1	1	1	1	1	
6	5LB-26302-02	THROTTLE CABLE ASSY	1	1	1	1	1	
7	90464-06214	CLAMP	1	1	1	1	1	
8	5EK-26335-00	CABLE, CLUTCH	1	1	1	1	1	
9	90123-08046	BOLT	1	1	1	1	1	
10	90179-08148	NUT	1	1	1	1	1	
11	1E6-26342-00	BOOT, CABLE	1	1	1	1	1	
12	1E6-26372-00	COVER, HANDLE LEVER 1	1	1	1	1	1	
13	3Y1-26290-10	BACK MIRROR ASSY (L.H)	1	1	1		1	
14	3Y1-26290-00	BACK MIRROR ASSY (R.H)	1	1	1		1	
15	3LN-26281-01	CAP, GRIP UPPER	1	1	1	1	1	
16	3LN-26282-01	CAP, GRIP LOWER	1	1	1	1	1	
17	98507-05020	SCREW, PAN HEAD	1	1	1	1	1	
18	98507-05025	SCREW, PAN HEAD	1	1	1	1	1	

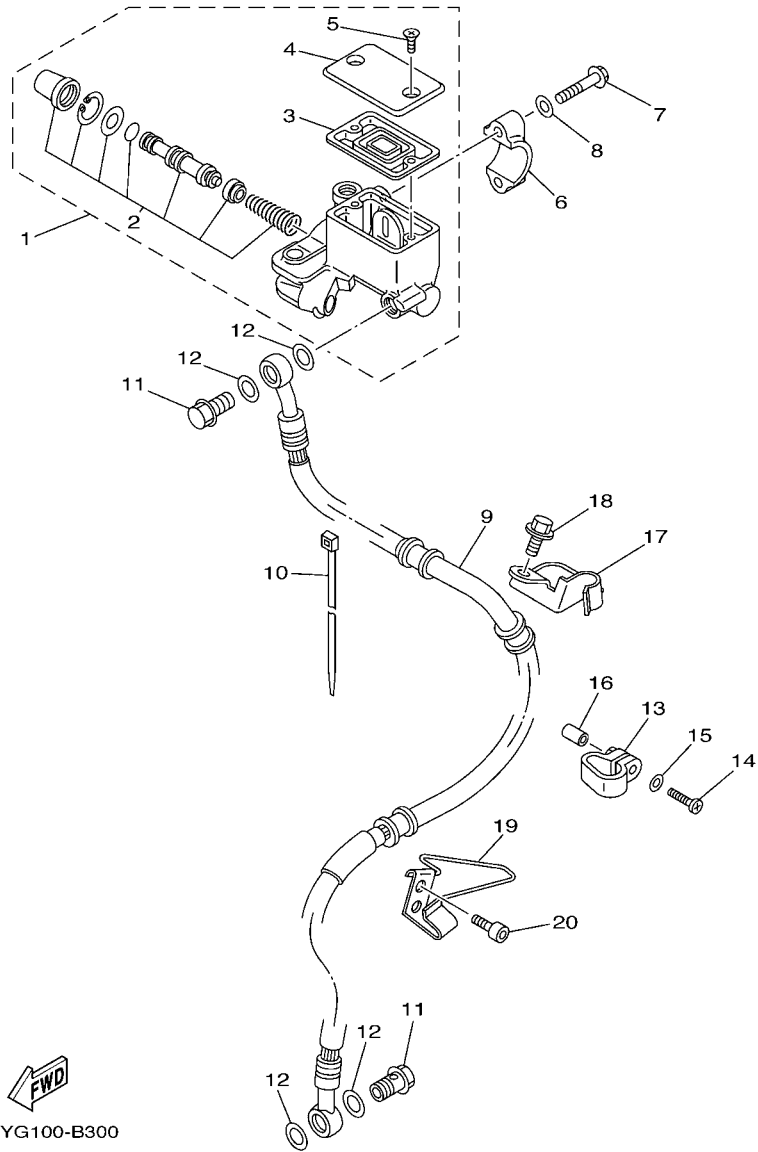
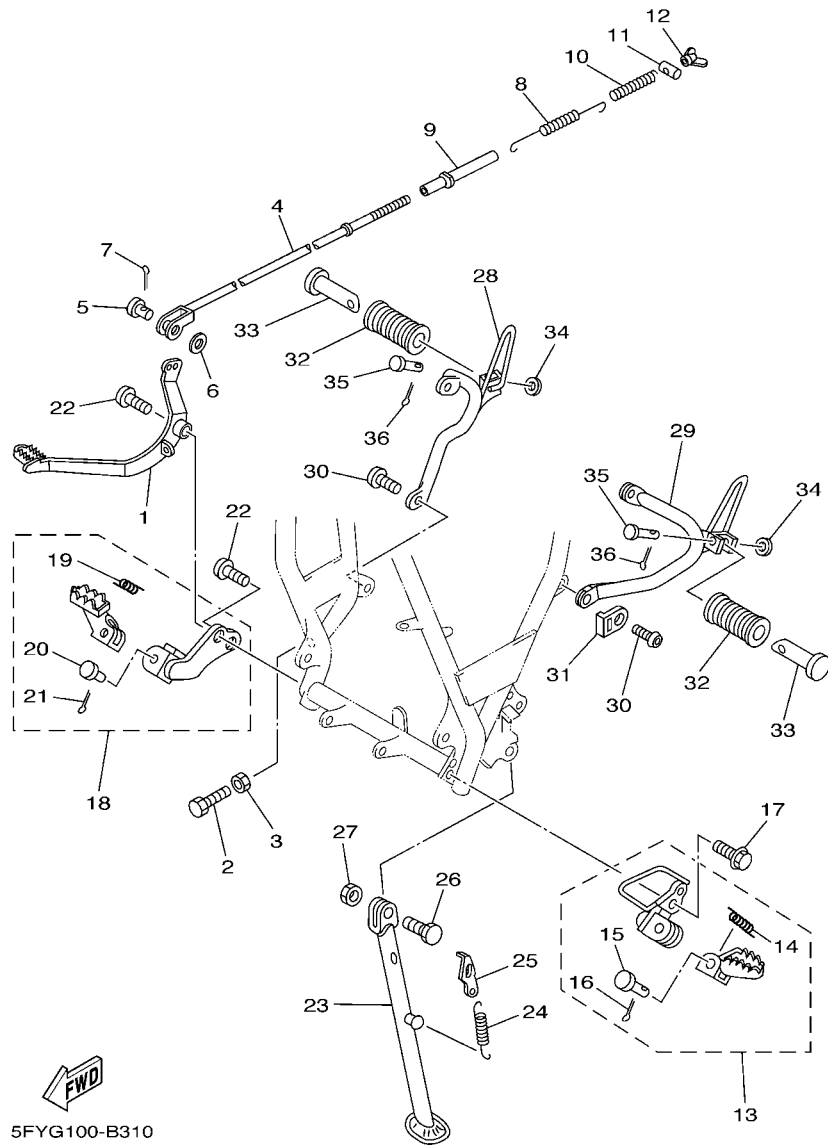

FIG. 30 FRONT MASTER CYLINDER

REF. NO.	PART NO.	DESCRIPTION	5FYV	5FYW	5FYX	3XTG	5FYV	REMARKS
1	5RS-25870-00	MASTER CYLINDER SUB ASSY	1	1	1	1	1	
2	5CG-W0041-00	.CYLINDER KIT, MASTER	1	1	1	1	1	
3	5RB-25854-00	.DIAPHRAGM, RESERVOIR	1	1	1	1	1	
4	4GY-25852-01	.CAP, RESERVOIR	1	1	1	1	1	
5	36Y-2589H-00	.SCREW	2	2	2	2	2	
6	3RW-25867-00	BRACKET, MASTER CYLINDER	1	1	1	1	1	
7	97007-06025	BOLT	2	2	2	2	2	
8	92907-06600	WASHER, PLATE	2	2	2	2	2	
9	5RS-25872-00	HOSE, BRAKE 1	1	1	1	1	1	
10	1UA-82591-00	BAND	1	1	1	1	1	
11	90401-10159	BOLT, UNION	2	2	2	2	2	
12	90201-10118	WASHER, PLATE	4	4	4	4	4	
13	3TB-23467-01	CLAMP	1	1	1	1	1	
14	98507-04018	SCREW, PAN HEAD	1	1	1	1	1	
15	92907-04600	WASHER	1	1	1	1	1	
16	90445-057G5	HOSE (L10)	1	1	1	1	1	
17	5RS-25886-00	HOLDER, BRAKE HOSE	1	1	1	1	1	
18	95807-06012	BOLT, FLANGE	1	1	1	1	1	
19	34X-25876-00	HOLDER, BRAKE HOSE 2	1	1	1	1	1	
20	91317-06010	BOLT	2	2	2	2	2	

FIG. 31 STAND & FOOTREST



REF. NO.	PART NO.	DESCRIPTION	5FYV	5FYW	5FYX	3XTG	5FYZ	REMARKS
1	2JX-27211-00-90	PEDAL, BRAKE	1	1	1	1	1	ZK
2	97007-06020	BOLT	1	1	1	1	1	
3	95307-06700	NUT	1	1	1	1	1	
4	2JX-27231-00	ROD, BRAKE	1	1	1	1	1	
5	90240-06076	PIN, CLEVIS	1	1	1	1	1	
6	92907-06200	WASHER	1	1	1	1	1	
7	91401-20012	PIN, COTTER	1	1	1	1	1	
8	90506-18289	SPRING, TENSION	1	1	1	1	1	
9	1M1-27244-00	COVER	1	1	1	1	1	
10	90501-10245	SPRING, COMPRESSION	1	1	1	1	1	
11	90249-12008	PIN	1	1	1	1	1	
12	90175-06013	NUT, WING	1	1	1	1	1	
13	2JX-27410-00-90	FRONT FOOTREST ASSY (LEFT)	1	1	1	1	1	ZK
14	90508-20023	.SPRING, TORSION	1	1	1	1	1	
15	91701-08038	.PIN, CLEVIS	1	1	1	1	1	
16	91401-25015	.PIN, COTTER	1	1	1	1	1	
17	95827-12025	BOLT, FLANGE	1	1	1	1	1	
18	15A-27420-02-90	FRONT FOOTREST ASSY (RIGHT)	1	1	1	1	1	ZK
19	90508-20023	.SPRING, TORSION	1	1	1	1	1	
20	91701-08038	.PIN, CLEVIS	1	1	1	1	1	
21	91401-25015	.PIN, COTTER	1	1	1	1	1	
22	90111-10004	BOLT, HEX. SOCKET BUTTON	2	2	2	2	2	
23	2JX-27311-02	STAND, SIDE	1	1	1	1	1	
24	90506-29360	SPRING, TENSION	1	1	1	1	1	
25	5RS-27315-00	LINK, SIDE STAND	1	1	1	1	1	
26	90109-10473	BOLT	1	1	1	1	1	
27	90185-10037	NUT, SELF-LOCKING	1	1	1	1	1	

FIG. 34 STARTING MOTOR

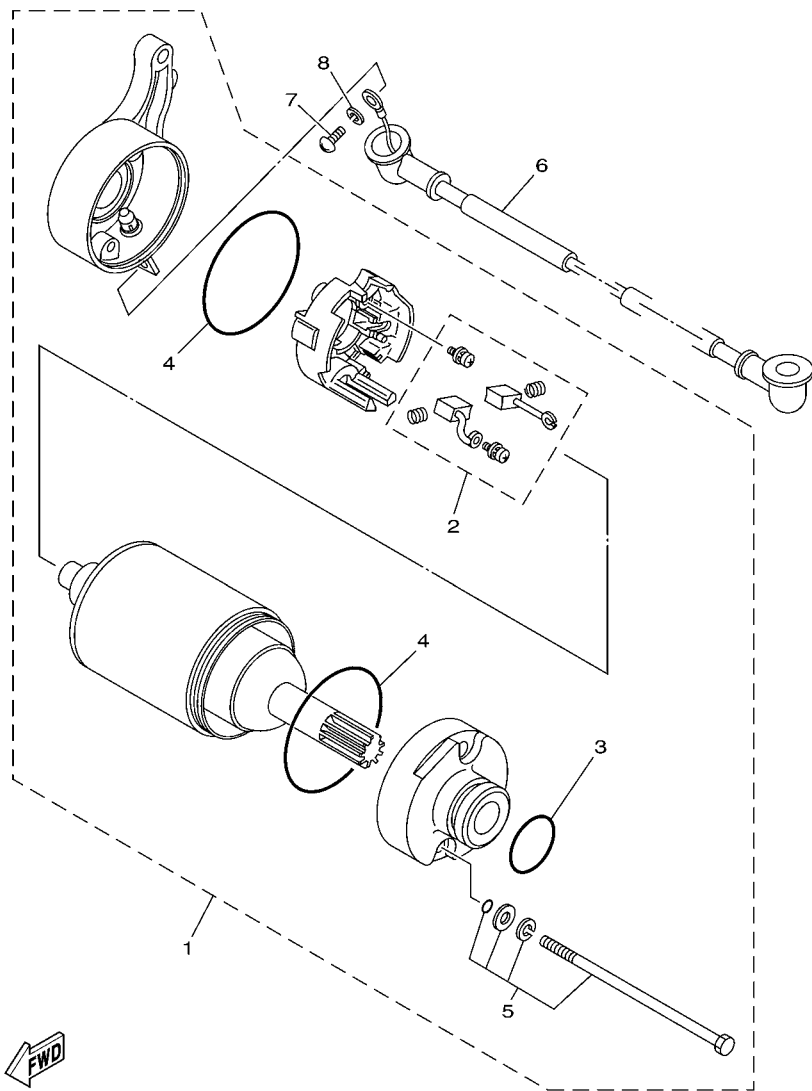

5FY5100-0320

REF. NO.	PART NO.	DESCRIPTION	5FYV	5FYW	5FYX	3XTG	5FYZ	REMARKS
1	2JX-81890-00	MOTOR ASSY	1	1	1	1	1	
2	50M-81801-M0	.BRUSH SET	1	1	1	1	1	
3	93210-25711	.O-RING	1	1	1	1	1	
4	93210-55669	.O-RING	2	2	2	2	2	
5	59V-81828-M0	.SCREW SET	2	2	2	2	2	
6	4JG-8183G-00	CORD COMP.	1	1	1	1	1	
7	98507-05008	SCREW, PAN HEAD	1	1	1	1	1	
8	92907-05100	WASHER, SPRING	1	1	1	1	1	

FIG. 35 FLASHER LIGHT

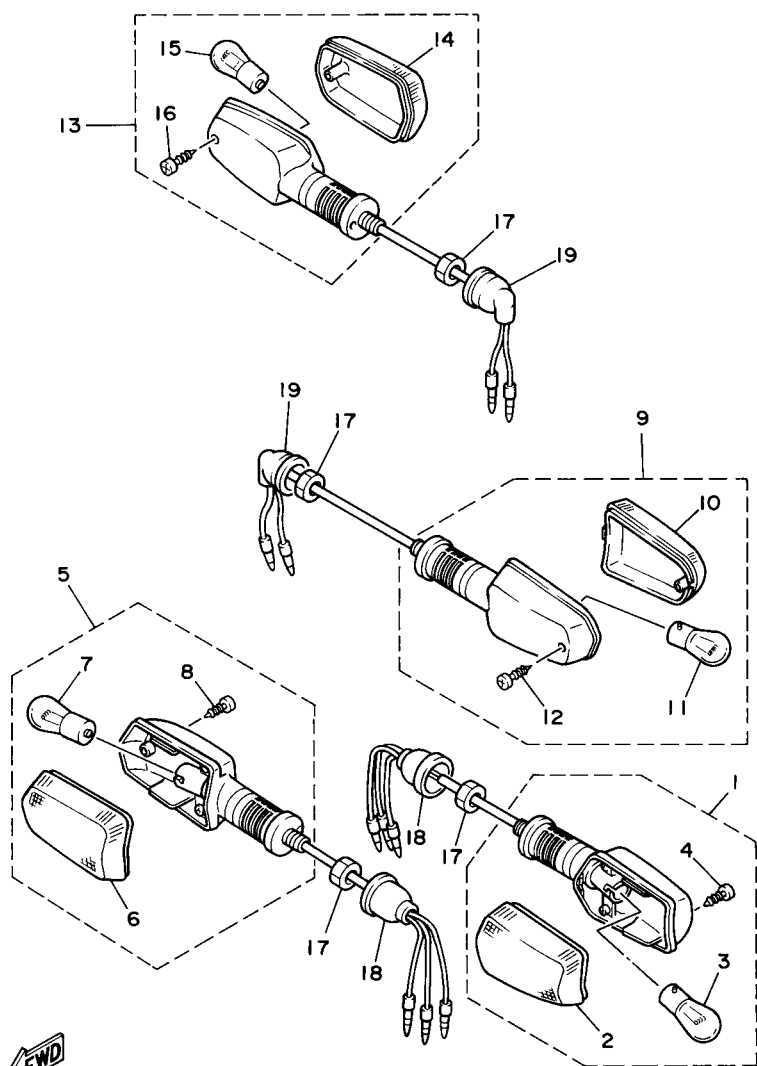

2YGI10-8330

REF. NO.	PART NO.	DESCRIPTION	5FYV	5FYW	5FYX	3XTG	5FYV	REMARKS
1	1UF-83310-00	FRONT FLASHER LIGHT ASSY 1	1	1	1		1	
2	51L-83332-01	.LENS, FLASHER	1	1	1		1	
3	256-84714-61	.BULB (12V-27/8W)	1	1	1		1	
4	97707-40620	.SCREW, TAPPING	1	1	1		1	
5	1UF-83320-00	FRONT FLASHER LIGHT ASSY 2	1	1	1		1	
6	51L-83342-01	.LENS, FLASHER 2	1	1	1		1	
7	256-84714-61	.BULB (12V-27/8W)	1	1	1		1	
8	97707-40620	.SCREW, TAPPING	1	1	1		1	
9	1UF-83330-00	REAR FLASHER LIGHT ASSY 1	1	1	1		1	
10	51L-83342-00	.LENS, FLASHER 2	1	1	1		1	
11	256-83311-70	.BULB (12V-27W)	1	1	1		1	
12	97706-40620	.SCREW, TAPPING	1	1	1		1	
13	1UF-83340-00	REAR FLASHER LIGHT ASSY 2	1	1	1		1	
14	51L-83332-00	.LENS, FLASHER	1	1	1		1	
15	256-83311-70	.BULB (12V-27W)	1	1	1		1	
16	97706-40620	.SCREW, TAPPING	1	1	1		1	
17	95307-12700	NUT	4	4	4		4	
18	10V-83365-00	CAP	2	2	2		2	
19	18G-83365-00	CAP	2	2	2		2	

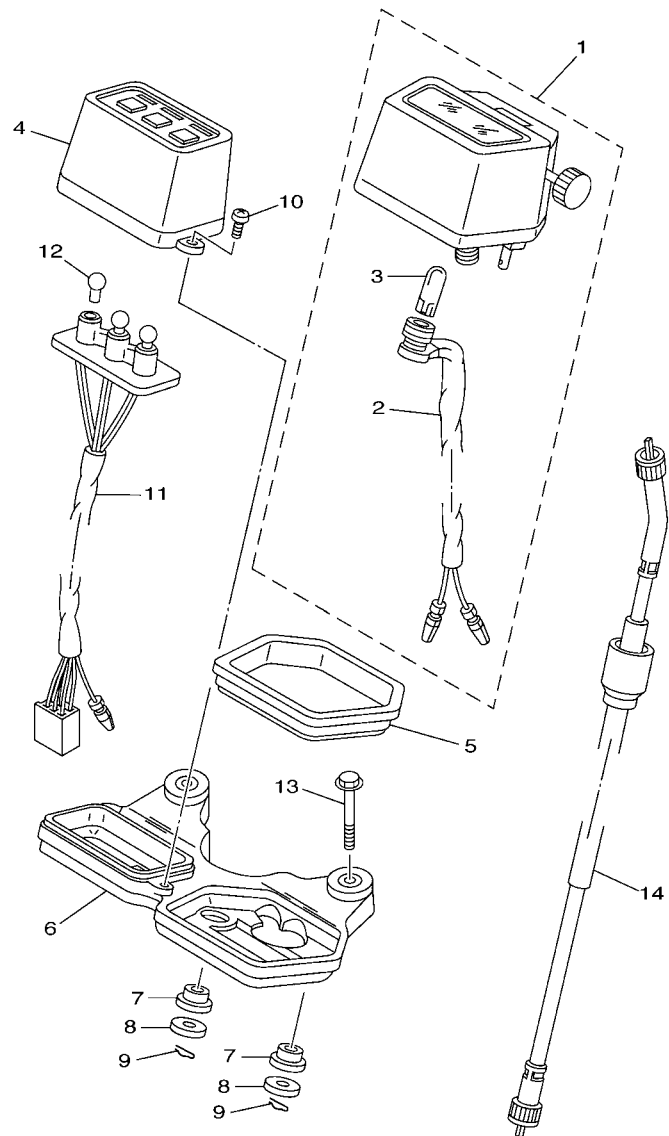

5FY8100-1360

FIG. 37 METER

REF. NO.	PART NO.	DESCRIPTION	5FY	5FYW	5FYX	3XTG	5FY	REMARKS
1	4CS-83510-00	SPEEDOMETER ASSY					1	
2	2JX-83536-A0	.SOCKET, METER	1	1	1	1	1	
3	4R0-83517-00	.BULB (12V-3.4W T10)	1	1	1	1	1	
4	5EK-83568-00	PILOT BOX, UPPER	1	1	1	1	1	
5	5Y1-83513-00	DAMPER	1	1	1	1	1	
6	15A-83519-00	BRACKET, METER	1	1	1	1	1	
7	1M1-83526-00	DAMPER 2	2	2	2	2	2	
8	90201-05033	WASHER, PLATE	2	2	2	2	2	
9	437-83525-00	CLIP	2	2	2	2	2	
10	90164-04008	SCREW, TAPPING	2	2	2	2	2	
11	15A-83509-00	SOCKET CORD ASSY	1	1	1	1	1	
12	123-83516-21	BULB (12V-3.4W)	3	3	3	3	3	
13	95807-06040	BOLT, FLANGE	2	2	2	2	2	
14	5LB-83550-00	SPEEDOMETER CABLE ASSY	1	1	1	1	1	

FIG. 38 HEADLIGHT

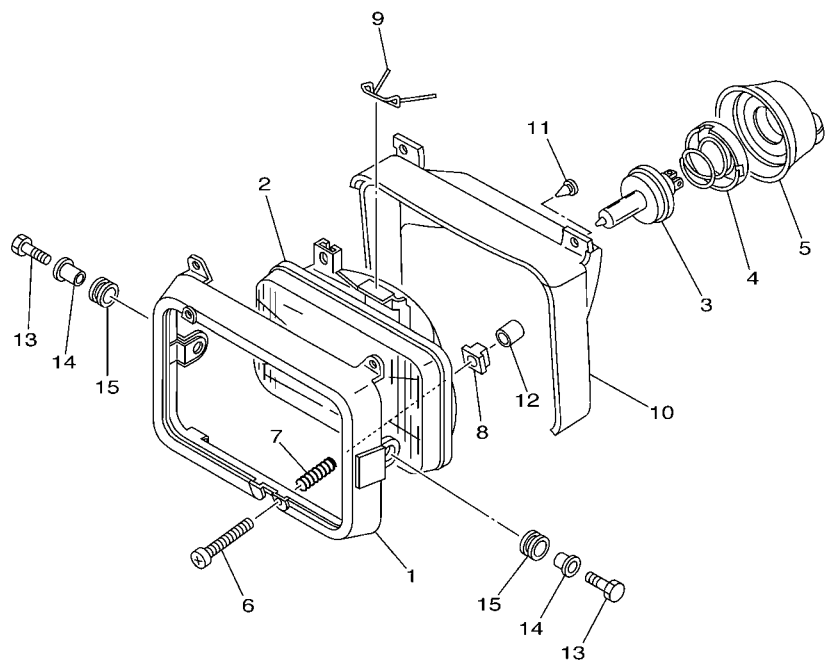

REF. NO.	PART NO.	DESCRIPTION	5FY	5FYW	5FYX	3XTG	5FY	REMARKS
1	47J-84115-00	RIM, HEADLIGHT	1	1	1	1	1	
2	5FY-84320-00	LENS ASSY	1	1	1	1	1	
3	2F9-84314-00	BULB (12V-60/55W)	1	1	1	1	1	LM (H4)HALOGEN
4	2F9-84375-00	SETTING PLATE, BULB	1	1	1	1	1	
5	2F9-84397-01	COVER, SOCKET	1	1	1	1	1	
6	43F-84131-00	SCREW, RIM ADJUSTER	2	2	2	2	2	
7	5G2-84332-60	SPRING, SCREW	2	2	2	2	2	
8	198-84334-60	NUT, ADJUSTING	2	2	2	2	2	
9	5G2-84324-A0	SPRING, REFLECTOR	1	1	1	1	1	
10	30X-84196-00	COVER, SOCKET	1	1	1	1	1	
11	10V-84198-00	CLIP, COVER FITTING	2	2	2	2	2	
12	2RR-84178-00	PLUG	1	1	1	1	1	
13	97007-06025	BOLT	2	2	2	2	2	
14	90387-063E6	COLLAR	2	2	2	2	2	
15	90480-14023	GROMMET	2	2	2	2	2	



5FY8100-1370

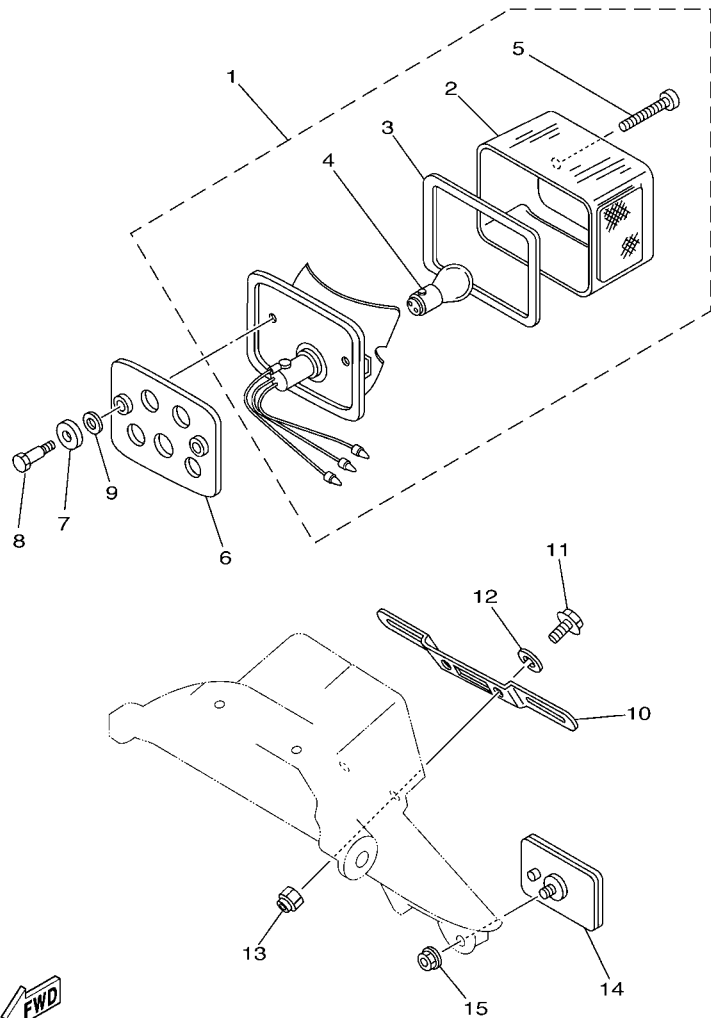

5FYG100-B390

FIG. 39 TAILLIGHT

REF. NO.	PART NO.	DESCRIPTION	5FY	5FYW	5FYX	3XTG	5FY	REMARKS
1	1W9-84710-61	TAILLIGHT UNIT ASSY	1	1	1		1	
2	1M1-84521-60	.LENS, TAILLIGHT	1	1	1		1	
3	1M1-84523-60	.GASKET, LENS	1	1	1		1	
4	256-84714-61	.BULB (12V-27/8W)	1	1	1		1	
5	1M1-84524-60	.SCREW, LENS FITTING	2	2	2		2	
6	4L0-84753-00	DAMPER	1	1	1		1	
7	90209-08125	WASHER	2	2	2		2	
8	90109-06005	BOLT	2	2	2		2	
9	90201-083A0	WASHER, PLATE	2	2	2		2	
10	36A-84551-00	BRACKET, LICENCE	1	1	1		1	
11	95807-06016	BOLT, FLANGE	2	2	2		2	
12	90201-06557	WASHER, PLATE	2	2	2		2	
13	95607-06100	NUT, U	2	2	2		2	
14	3G1-85130-01	REAR REFLECTOR ASSY	1	1	1		1	
15	95707-05500	NUT, FLANGE	1	1	1		1	

FIG. 41 HANDLE SWITCH & LEVER

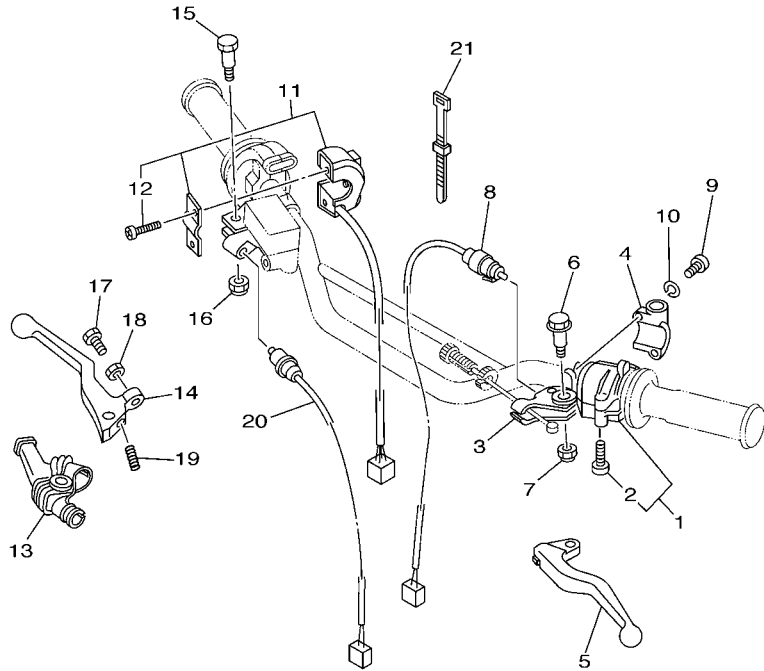

REF. NO.	PART NO.	DESCRIPTION	5FYV	5FYW	5FYX	3XTG	5FYV	REMARKS
1	4CS-83973-00	SWITCH, HANDLE 3	1	1	1	1	1	
2	98507-05030	.SCREW, PAN HEAD	2	2	2	2	2	
3	1LN-82911-00	HOLDER, LEVER 1	1	1	1	1	1	
4	33G-82913-01	HOLDER, LEVER LOWER 1	1	1	1	1	1	
5	4GY-83912-00	LEVER 1	1	1	1	1	1	
6	90109-06799	BOLT	1	1	1	1	1	
7	95607-06100	NUT, U	1	1	1	1	1	
8	4GY-82917-01	SWITCH	1	1	1	1	1	
9	98507-05020	SCREW, PAN HEAD	2	2	2	2	2	
10	92907-05100	WASHER, SPRING	2	2	2	2	2	
11	5LB-83975-00	SWITCH, HANDLE 2	1	1	1	1	1	
12	98507-05018	.SCREW, PAN HEAD	2	2	2	2	2	
13	1T5-26372-00	COVER, HANDLE LEVER 1	1	1	1	1	1	
14	55Y-83922-00	LEVER 2	1	1	1	1	1	
15	90109-06577	BOLT	1	1	1	1	1	
16	95607-06100	NUT, U	1	1	1	1	1	
17	90149-06131	SCREW	1	1	1	1	1	
18	90170-06010	NUT	1	1	1	1	1	
19	90501-10312	SPRING, COMPRESSION	1	1	1	1	1	
20	3DM-83980-00	FRONT STOP SWITCH ASSY	1	1	1	1	1	
21	437-83936-01	BAND, SWITCH CORD	4	4	4	4	4	



5LB1010-0500

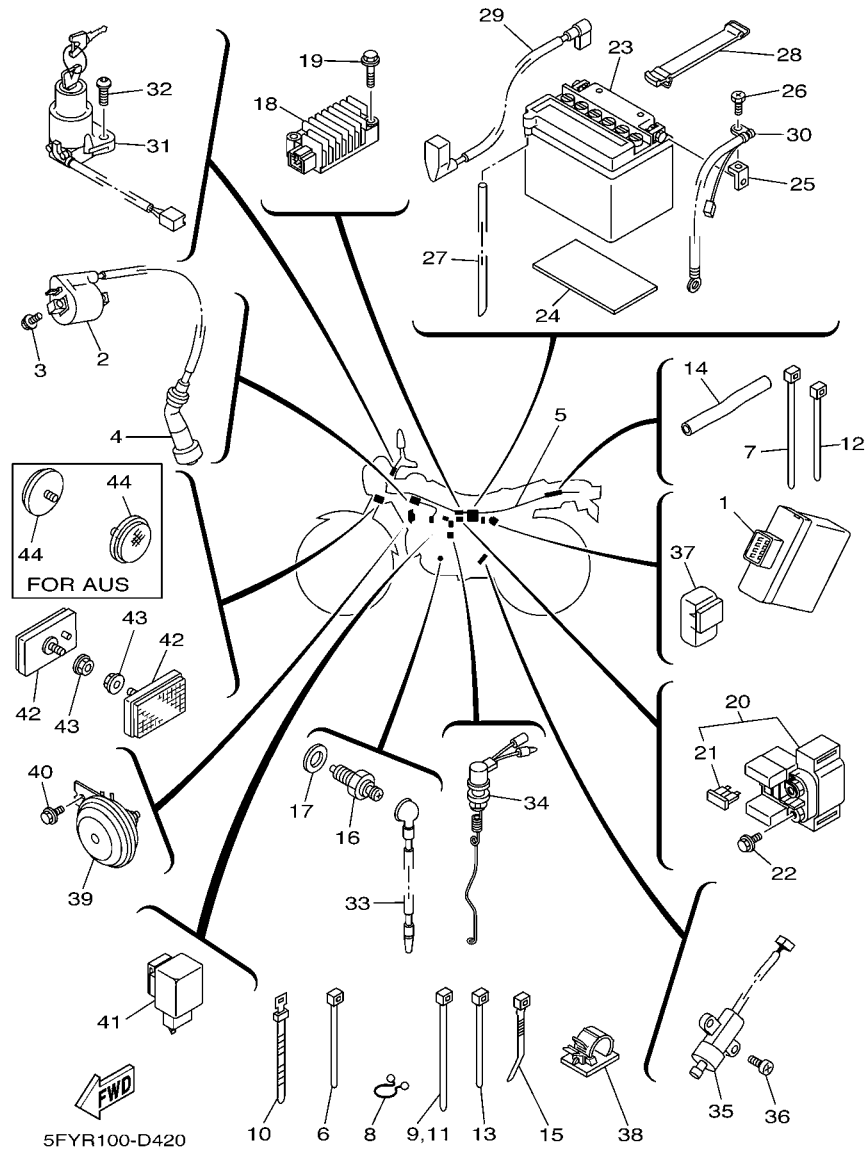

FIG. 42 ELECTRICAL 1

REF. NO.	PART NO.	DESCRIPTION	5FYV	5FYW	5FYX	3XTG	5FYV	REMARKS
1	5LB-85540-00	C.D.I. UNIT ASSY	1	1	1	1	1	
2	3RW-82310-10	IGNITION COIL ASSY	1	1	1	1	1	
3	95027-06016	BOLT, FLANGE	2	2	2	2	2	
4	1UY-82370-20	PLUG CAP ASSY	1	1	1	1	1	
5	5FY-82590-10	WIRE HARNESS ASSY	1	1	1	1	1	
6	5Y9-12491-00	CLAMP 1	1	1	1	1	1	
7	1UA-82591-00	BAND	1	1	1	1	1	
8	341-82594-00	CLAMP	1	1	1	1	1	
9	1UA-82591-00	BAND	1	1	1	1	1	
10	25G-83936-01	BAND, SWITCH CORD	2	2	2	2	2	
11	1UA-82591-00	BAND	2	2	2	2	2	
12	5Y9-12491-00	CLAMP 1	1	1	1	1	1	
13	5Y9-12491-00	CLAMP 1	2	2	2	2	2	
14	90446-15377	HOSE	2	2	2	2	2	
15	90465-10098	CLAMP	3	3	3	3	3	
16	4GY-82540-10	NEUTRAL SWITCH ASSY	1	1	1	1	1	
17	90430-10148	GASKET	1	1	1	1	1	
18	3TJ-81960-02	RECTIFIER & REGULATOR ASSY	1	1	1	1	1	
19	95027-06025	BOLT, FLANGE	2	2	2	2	2	
20	5EK-81940-02	STARTER RELAY ASSY	1	1	1	1	1	
21	2GH-82151-00	.FUSE (20A-BL)	2	2	2	2	2	
22	95027-06008	BOLT, FLANGE	2	2	2	2	2	
23	1JE-82110-61	BATTERY ASSY (GS GM7CZ-3D)	1	1	1	1	1	
24	51Y-82122-00	SEAT, BATTERY	1	1	1	1	1	
25	5LB-8215C-00	TERMINAL	2	2	2	2	2	
26	90153-06001	SCREW, HEXAGON	2	2	2	2	2	

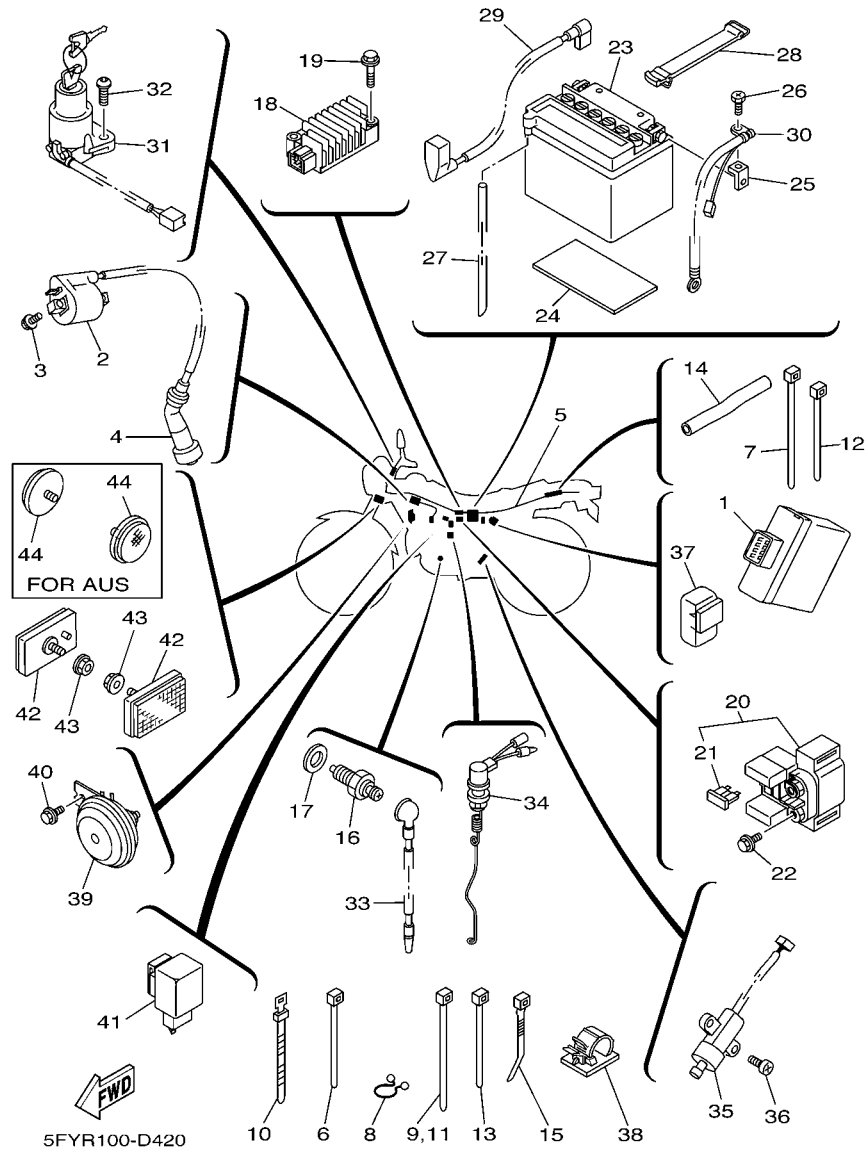

FIG. 42 ELECTRICAL 1

REF. NO.	PART NO.	DESCRIPTION	5FYV	5FYW	5FYX	3XTG	5FYZ	REMARKS
27	90445-082F3	HOSE (L540)	1	1	1	1	1	
28	18G-82131-00	BAND, BATTERY	1	1	1	1	1	
29	5LB-82115-00	WIRE, PLUS LEAD	1	1	1	1	1	
30	5EK-82116-02	WIRE, MINUS LEAD	1	1	1	1	1	
31	5LB-82501-01	MAIN SWITCH STEERING LOCK	1	1	1	1	1	
32	90149-06228	SCREW	2	2	2	2	2	
33	5VC-82541-00	WIRE, LEAD	1	1	1	1	1	
34	5VC-82530-00	STOP SWITCH ASSY	1	1	1	1	1	
35	3LD-82566-60	SWITCH, SIDE STAND	1	1	1	1	1	
36	90157-05008	SCREW, PAN HEAD	2	2	2	2	2	
37	29U-81950-93	RELAY ASSY	1	1	1	1	1	
38	90464-13004	CLAMP	1	1	1	1	1	
39	5LB-83371-11	HORN	1	1	1	1	1	
40	95807-06012	BOLT, FLANGE	1	1	1	1	1	
41	4MY-83350-01	FLASHER RELAY ASSY	1	1	1	1	1	
42	20G-85110-00	REFLECTOR ASSY	2	2	2	2	2	
43	95707-05500	NUT, FLANGE	2	2	2	2	2	
44	N/A							

NUMERICAL INDEX

PART NO.	GRID NO.	PART NO.	GRID NO.	PART NO.	GRID NO.	PART NO.	GRID NO.	PART NO.	GRID NO.	PART NO.	GRID NO.
15A-11110-04	B - 2	5Y9-12491-00	E - 12	2JL-14437-00	B - 9	2JX-16356-00	C - 3	5A8-21639-00	C - 11	5EK-23136-00	D - 3
5H0-1111F-00	B - 2	5H0-13300-02	B - 8	34X-1443E-00	B - 9	5H0-16357-00	C - 3	2JX-21641-00	C - 11	5RS-23136-10	D - 3
5H0-11133-11	B - 2	5H0-13326-01	B - 8	2JX-14451-00	B - 9	1W1-16358-01	C - 3	2JX-21651-10	C - 11	2JL-23141-00	D - 3
15A-11161-01	B - 2	4BE-13329-01	B - 8	2JX-14452-00	B - 9	2JX-16371-00	C - 3	3XT-21668-A0	C - 11	2JX-23141-00	D - 3
15A-11162-00	B - 2	51Y-13411-00	B - 8	5LB-14453-10	B - 9	15A-16380-00	C - 3	3XT-21668-B0	C - 11	54G-23144-00	D - 3
5H0-11162-00	B - 2	5H0-13440-09	B - 8	5U8-14457-00	B - 9	15A-17121-00	C - 5	2JX-21669-00	C - 11	22W-23145-L0	D - 3
3Y1-11166-00	B - 13	15A-13447-00	B - 8	2JX-14458-00	B - 9	5H0-17121-01	C - 5	2JL-21685-00	E - 10	3DM-23149-10	D - 3
371-11167-01	B - 13	5LB-13584-00	B - 9	5LB-14589-00	B - 10	15A-17141-00	C - 5	2JX-21685-00	C - 11	22W-23153-L0	D - 3
1NU-11181-00	B - 2	5LB-13586-02	B - 9	5LB-14592-00	B - 11	15A-17151-01	C - 5	4YN-21686-00	C - 13	509-23158-L0	D - 3
15A-11185-00	B - 2	5LB-14105-00	B - 10	2JX-14611-02	B - 12	15A-17211-01	C - 5	5VC-21691-00	C - 11	2JX-23170-00	D - 3
15A-11186-00	B - 2	2JX-14148-01	B - 11	5H0-14612-01	B - 12	15A-17221-00	C - 5	2YG-21711-00-0X	C - 13	3R6-23173-L0	D - 3
15A-11187-00	B - 2	2JX-14193-00	B - 11	4BE-14613-00	B - 12	15A-17231-00	C - 5	2YG-21721-00-0X	C - 13	5FY-23174-00	D - 2
47J-11310-00	B - 3	5FY-14196-00	B - 11	5LB-14628-00	B - 12	15A-17241-00	C - 5	5FY-2173E-60	C - 13	278-23181-50	D - 3
5VC-11351-00	B - 3	5LB-14196-00	B - 11	2JX-14711-10	B - 12	1EV-17251-00	C - 5	5FY-2173F-60	C - 13	4CS-23191-20	D - 4
5H0-11400-01	B - 4	5FY-14197-00	B - 11	2JL-14711-21	B - 12	2JX-17402-00	C - 5	5EK-2175T-00	C - 13	2K5-23192-00	D - 4
5H0-11412-09	B - 4	5LB-14197-00	B - 11	3YF-14714-00	B - 12	15A-17411-01	C - 5	5EK-2175U-00	C - 13	1W4-23194-L0	D - 4
5H0-11422-00	B - 4	5LB-14216-00	B - 10	2JX-17428-00	B - 12	2JX-17456-00	C - 5	5EK-2177A-00	C - 13	34X-23197-00	D - 4
15A-11454-00	B - 4	5LB-14275-00	B - 10	1RH-14752-01	B - 12	2JX-17471-00	C - 6	5FY-2179N-70	C - 13	5LB-23340-00	D - 4
5H0-11496-00	B - 4	5LB-14286-00	B - 10	5LB-14936-00	B - 10	1RL-18110-00	C - 8	5FY-2179V-70	C - 13	5RS-23346-00	D - 4
5H0-11531-00	B - 4	5LB-14292-00	B - 11	1RL-15100-03	B - 13	132-18113-01	C - 8	2JX-22110-00-35	C - 14	156-23411-00	D - 4
5H0-11536-00	B - 4	5LB-14293-00	B - 10	55X-15167-00	B - 14	5H0-18120-02	C - 8	2JX-22123-00	C - 14	22F-23411-01	D - 2
15A-11603-00	B - 4	5FY-14301-00	B - 10	5H0-15351-00	B - 8	1RH-18140-00	C - 7	2JX-22124-00	C - 14	156-23412-00	D - 2
15A-11605-00	B - 4	5LB-14301-01	B - 10	3Y1-15361-00	B - 14	1RH-18185-00	C - 7	401-22127-00	C - 14	22F-23412-01	D - 2
15A-11607-00	B - 4	5FY-14301-10	B - 10	3Y1-15363-00	B - 14	4JG-18511-00	C - 7	401-22128-01	C - 14	36X-23416-00	D - 2
36X-11631-00-A0	B - 4	5LB-14321-00	B - 10	2JX-15377-00	B - 14	4JG-18512-01	C - 7	30X-22129-00	C - 15	156-2341E-00	D - 2
15A-11633-00	B - 4	4JP-14323-00	B - 11	5EK-15410-00	B - 14	4JG-18513-00	C - 7	2JX-22141-00	C - 14	22F-2341E-00	D - 2
36X-11636-00	B - 4	4KN-1432A-00	B - 11	15A-15431-01	B - 14	3GX-18531-00	C - 7	34X-22151-01	C - 14	2JX-23435-00-35	D - 2
36X-11638-00	B - 4	2JX-14333-00	B - 10	15A-15441-00	B - 3	3GX-18535-00	C - 7	5BT-22199-00	C - 14	1E6-23441-10-35	D - 2
15A-11651-00	B - 4	5FY-14336-00	B - 10	3AW-15451-03	B - 14	5N0-18540-00	C - 7	5FY-22210-00-P0	C - 15	30X-23445-00	D - 2
5H0-11681-00	B - 4	5LB-14336-00	B - 10	4BE-15462-00	B - 14	136-18542-00	C - 7	5FY-22210-10-P0	C - 15	164-23462-00	D - 4
5H0-12111-02	B - 6	5LB-14341-00	B - 10	2HT-15512-00	B - 15	3XT-21110-31	C - 9	5FY-22210-20-P0	C - 15	3TB-23467-01	D - 13
11H-12113-00	B - 6	5LB-14341-10	B - 10	5H0-15517-00	B - 15	5FY-21110-61	C - 9	1M1-22216-00	C - 15	5VX-2411B-00	D - 5
11H-12114-00	B - 6	5LB-14342-65	B - 10	5H0-15521-00	B - 15	5FY-21110-71	C - 9	4AA-22259-40	C - 15	2JX-24141-00	D - 6
4G0-12116-01	B - 6	288-14343-63	B - 10	4H7-15580-10	B - 15	5GK-2118K-00	D - 6	4AA-22259-70	C - 15	4BE-24170-00	D - 5
4G0-12117-00	B - 6	288-14343-64	B - 10	1J7-15583-01	C - 2	5GK-2118K-10	D - 6	4AA-22259-80	C - 15	20K-24180-00	D - 6
4G0-12118-00	B - 6	288-14343-66	B - 10	54G-15620-00	B - 15	2JX-21190-00-P1	C - 10	34X-22311-00	C - 14	22W-24181-00	B - 12
5H0-12119-00	B - 6	5LB-1434A-00	B - 10	54G-15621-00	B - 15	4R8-21308-00	C - 9	5LB-23102-00	D - 3	4L0-24181-00	D - 5
5H0-12121-01	B - 6	50M-14355-00	B - 10	36X-15641-00	B - 15	5VC-21315-00	C - 9	5FY-23102-20	D - 3	30X-24182-01	D - 5
5H0-12146-00	B - 6	5LB-14357-00	B - 10	15A-15651-01	B - 15	1RL-21316-00-P2	C - 9	5LB-23103-00	D - 3	30X-24183-01	D - 5
36X-12151-00	B - 6	5LB-14368-00	B - 10	15A-15660-01	B - 15	2JX-21316-01-P1	C - 9	5FY-23103-20	D - 3	30X-24186-01	D - 5
5H0-12156-00	B - 6	5FY-14371-00	B - 10	15A-15666-00	B - 15	1RL-21337-00	C - 9	2JX-23110-00	D - 3	30X-24187-00	D - 5
2NX-12159-00	B - 6	5LB-14384-00	B - 11	401-15676-00	B - 15	1RL-21471-00-35	C - 9	2JN-23111-00	D - 3	5FY-24240-60	D - 5
36X-12171-00	B - 7	5LB-14385-00	B - 11	5H0-16111-00	C - 3	34L-21485-00	C - 9	3J2-23114-00	D - 3	23F-24500-11	D - 5
1KH-12176-00	B - 7	5LB-14386-00	B - 11	15A-16150-00	C - 3	2YG-21511-00	C - 11	2JL-23118-00	D - 3	4X8-24512-00	D - 5
3GC-12210-10	B - 7	5LB-14390-00	B - 11	5H0-16154-00	C - 3	2JX-21512-00	C - 11	22U-23118-01	D - 3	3AC-24523-00	D - 5
4FM-12213-00	B - 7	2JX-14411-02	B - 9	53P-16321-00	C - 3	5PA-21568-00	D - 6	51Y-23125-00	D - 3	3AJ-24534-01	D - 5
5H0-12231-00	B - 7	2JX-14412-00	B - 9	137-16324-00	C - 3	2YG-21611-00	C - 11	5EK-23126-00	D - 3	214-24535-00	B - 10
5N0-12241-00	B - 7	2JX-14422-00	B - 9	5H0-16351-00	C - 3	4G0-21639-00	C - 11	5RS-23126-10	D - 3	51K-24602-01	D - 5

NUMERICAL INDEX

PART NO.	GRID NO.	PART NO.	GRID NO.	PART NO.	GRID NO.	PART NO.	GRID NO.	PART NO.	GRID NO.	PART NO.	GRID NO.
11H-24602-03	D - 5	1LX-26242-01	D - 12	116-82131-00	C - 13	4R0-83517-00	E - 7	5BT-85550-00	E - 3	90154-05004	C - 11
18A-24723-00	D - 7	5BE-26243-00	D - 12	18G-82131-00	E - 13	15A-83519-00	E - 7	4JG-85580-01	E - 3	90154-05005	B - 9
2JX-24731-00	D - 7	3Y1-26249-00	D - 12	3TJ-82131-00	C - 10	437-83525-00	E - 7	5CG-W0041-00	D - 13	90154-05013	C - 13
2JX-24734-80	D - 7	3LN-26281-01	D - 12	2GH-82151-00	E - 12	1M1-83526-00	E - 7	5LB-W0045-01	D - 9	90157-05008	E - 13
1L9-24741-A0	D - 7	3LN-26282-01	D - 12	5LB-8215C-00	E - 12	2JX-83536-A0	E - 7	4JG-W0047-00	D - 9	90159-05011	C - 3
5FY-24770-10	D - 7	3Y1-26290-00	D - 12	3RW-82310-10	E - 12	5LB-83550-00	E - 7	51L-W0048-00	D - 9	90159-05028	C - 11
3MX-24875-A0	C - 11	3Y1-26290-10	D - 12	1UY-82370-20	E - 12	5EK-83568-00	E - 7	4JG-W0057-00	D - 9	90159-06060	E - 2
3MX-24875-B0	C - 11	1Y1-26290-50	D - 12	5LB-82501-01	E - 13	4GY-83912-00	E - 11	4KN-W253E-11	D - 10	90164-04008	E - 7
3TB-24877-A0	C - 11	1Y1-26290-60	D - 12	5VC-82530-00	E - 13	55Y-83922-00	E - 11	5RS-Y2410-10-07	D - 5	90170-06010	E - 11
3TB-24877-B0	C - 11	5LB-26302-02	D - 12	4GY-82540-10	E - 12	25G-83936-01	E - 12	5RS-Y2410-30-05	D - 5	90170-06128	B - 6
5EK-25111-00	D - 8	5EK-26335-00	D - 12	5VC-82541-00	E - 13	437-83936-01	E - 11	90101-06278	D - 10	90170-14284	B - 5
152-25115-00	D - 10	1E6-26342-00	D - 12	3LD-82566-60	E - 13	4CS-83973-00	E - 11	90101-10188	B - 5		C - 3
322-25118-00	D - 8	1E6-26372-00	D - 12	5FY-82590-10	E - 12	5LB-83975-00	E - 11	90101-10303	B - 7	90175-06013	D - 14
5V7-2511E-00-35	D - 10	1T5-26372-00	E - 11	3XT-82590-30	E - 12	3DM-83980-00	E - 11	90105-06014	B - 14	90179-08148	D - 12
2N3-25155-00	D - 10	128-27114-00	C - 9	1UA-82591-00	D - 13	47J-84115-00	E - 8	90105-06017	B - 14	90179-08410	D - 10
2JX-25181-10	D - 8	4N0-27114-00	C - 9			43F-84131-00	E - 8	90105-065A1	B - 8	90179-25033	D - 2
54G-25185-00	D - 10	2JX-27211-00-90	D - 14	341-82594-00	E - 12	2RR-84178-00	E - 8	90105-08066	C - 9	90185-08055	C - 9
50W-25188-00	C - 15	2JX-27231-00	D - 14	1LN-82911-00	E - 11	30X-84196-00	E - 8	90105-08195	B - 2	90185-08089	C - 9
5EK-25190-00	D - 8	1M1-27244-00	D - 14	33G-82913-01	E - 11	10V-84198-00	E - 8	90105-10638	D - 9		D - 10
4TP-25304-10	D - 8	2JX-27311-02	D - 14	4GY-82917-01	E - 11	2F9-84314-00	E - 8	90105-14102	D - 2	90185-10037	D - 14
2JX-25304-21	D - 10	5RS-27315-00	D - 14	1UF-83310-00	E - 5	5FY-84320-00	E - 8	90109-06005	E - 9	90185-12134	C - 14
2JX-25311-00	D - 10	2JX-27410-00-90	D - 14	5Y3-83310-21	E - 6	5G2-84324-A0	E - 8		E - 10	90185-16127	D - 11
2JX-25321-02-35	D - 10	15A-27420-02-90	D - 14	306-83311-40	E - 6	5G2-84332-60	E - 8	90109-06419	B - 8	90201-04018	C - 13
2JX-25336-00	D - 10	120-27431-00	D - 15	256-83311-70	E - 5	198-84334-60	E - 8	90109-06577	E - 11	90201-05015	B - 12
2JX-2533A-00	D - 10	5RS-27432-01	D - 15	5Y1-83312-00	E - 6	2F9-84375-00	E - 8	90109-065G4	D - 9	90201-05033	E - 7
3Y6-25351-00	D - 10	120-27433-00	D - 15	5Y3-83312-00	E - 6	2F9-84397-01	E - 8	90109-06799	E - 11	90201-06059	D - 7
36R-25367-00	D - 11	2JX-27437-00	D - 15	5Y1-83313-00	E - 6	1M8-84521-40	E - 10	90109-08618	D - 10	90201-06557	E - 9
2JX-25381-10	D - 11	2JX-27442-11	D - 15	1UF-83320-00	E - 5	1M1-84521-60	E - 9	90109-100E2	C - 15		E - 10
3Y1-25388-01	D - 11	3MA-27491-00	C - 10	5Y3-83320-21	E - 6	1M1-84523-60	E - 9	90109-10473	D - 14	90201-08326	B - 12
3Y1-25389-00	D - 11		C - 14	1UF-83330-00	E - 5		E - 10	90111-10004	D - 14	90201-08366	C - 9
3HT-25398-00	D - 11	5VC-28100-00	C - 10	5Y3-83330-41	E - 6	1M1-84524-60	E - 9	90119-05059	C - 14	90201-083A0	E - 9
5LB-25445-00	D - 10	3JL-28177-A0	C - 13	51L-83332-00	E - 5		E - 10	90119-05062	C - 14		E - 10
15A-25450-20	D - 10	3JL-28177-B0	C - 13	51L-83332-01	E - 5	36A-84551-00	E - 9	90119-06056	B - 9	90201-08609	B - 2
5LB-2580T-01	D - 9	34Y-28351-10	E - 2	1UF-83340-00	E - 5	56U-84710-41	E - 10		C - 11	90201-086P8	D - 11
5XT-2582T-00	D - 9	5FY-28390-20	E - 2	5Y3-83340-41	E - 6	1W9-84710-61	E - 9		C - 13	90201-100E9	C - 15
4GY-25852-01	D - 13	3JJ-28446-A1	C - 12	51L-83342-00	E - 5	1A2-84714-41	E - 10	90119-06063	B - 9	90201-10118	D - 13
5RB-25854-00	D - 13	3JJ-28446-B1	C - 12	51L-83342-01	E - 5	256-84714-61	E - 5		C - 11	90201-10508	B - 5
3RW-25867-00	D - 13	50M-81801-M0	E - 4	4MY-83350-01	E - 13		E - 9		D - 7	90201-10591	B - 7
5RS-25870-00	D - 13	59V-81828-M0	E - 4	10V-83365-00	E - 5	4L0-84753-00	E - 9	90123-08046	D - 12	90201-120E8	C - 14
5RS-25872-00	D - 13	4JG-8183G-00	E - 4		E - 6		E - 10	90149-06011	D - 5	90201-12588	C - 8
34X-25876-00	D - 13	2JX-81890-00	E - 4	18G-83365-00	E - 5	20G-85110-00	E - 13	90149-06131	E - 11	90201-12749	C - 15
5RS-25886-00	D - 13	5EK-81940-02	E - 12		E - 6	4AG-85111-00	E - 13	90149-06228	E - 13	90201-14740	D - 8
36Y-2589H-00	D - 13	29U-81950-93	E - 13	5LB-83371-11	E - 13	3UN-85112-00	D - 4	90149-08067	C - 3	90201-164H4	D - 11
5JW-25914-10	D - 9	3TJ-81960-02	E - 12	15A-83509-00	E - 7	49R-85112-00	D - 4	90151-06013	C - 7	90201-17257	C - 5
4TT-25919-00	D - 9	1JE-82110-61	E - 12	4CS-83510-00	E - 7	4KM-85130-00	E - 10	90151-06018	C - 9	90201-173F4	B - 15
4TT-25937-00	D - 9	5LB-82115-00	E - 13	2JX-83510-B0	E - 7	3G1-85130-01	E - 9	90152-06010	B - 15	90201-175F6	B - 15
5LB-26111-00	D - 12	5EK-82116-02	E - 13	5Y1-83513-00	E - 7	4WP-85510-10	E - 3	90153-06001	E - 12	90201-201E4	B - 4
1LX-26241-01	D - 12	51Y-82122-00	E - 12	123-83516-21	E - 7	5LB-85540-00	E - 12	90153-06029	B - 2	90201-20279	D - 15

NUMERICAL INDEX

PART NO.	GRID NO.	PART NO.	GRID NO.	PART NO.	GRID NO.	PART NO.	GRID NO.	PART NO.	GRID NO.	PART NO.	GRID NO.
90201-220J8	C - 5	90430-06014	B - 13	90506-18289	D - 14	93102-22389	C - 5	94118-145U1	D - 10	95807-06020	C - 14
90201-25290	B - 15	90430-08119	C - 3	90506-29360	D - 14	93102-25311	D - 10	94213-18232	D - 8	95807-06040	E - 7
90202-05191	B - 12	90430-10148	E - 12	90508-18537	C - 3	93109-18020	C - 14	94218-14251	D - 10	95807-08012	B - 11
90202-05193	D - 5	90430-14131	B - 2	90508-20023	D - 14	93210-07135	B - 8	94318-14149	D - 10	95817-08016	B - 12
90206-06090	B - 12	90445-057G5	D - 13	90508-26538	B - 15	93210-09165	B - 6	94340-18086	D - 8	95817-08050	C - 9
90209-06187	C - 14	90445-082F3	E - 13	90508-26539	C - 7	93210-10166	D - 6	94425-18603	D - 8	95817-08065	C - 9
90209-08125	E - 9	90445-10007	D - 5	90508-29540	C - 8	93210-13361	B - 3	94445-14479	D - 10	95817-08120	C - 9
	E - 10	90445-10017	D - 6	90560-15312	D - 8	93210-14369	B - 14	94580-41104	B - 7	95824-08035	D - 2
90209-16209	C - 5	90445-10018	D - 6	90560-17305	D - 10	93210-19123	B - 14	94580-88120	D - 11	95827-06012	C - 10
90209-17226	B - 15	90445-11M27	D - 6	90560-17368	C - 6	93210-25711	E - 4	94580-88122	D - 11	95827-12025	D - 14
90209-18208	C - 5	90446-15377	E - 12	91317-06010	B - 14	93210-32172	B - 14	94680-88001	D - 11	97007-05010	C - 5
90214-17028	B - 15	90450-44062	B - 9		D - 13	93210-347A1	B - 8	94701-00222	B - 2	97007-06012	B - 2
90214-20023	B - 4	90460-51059	B - 9	91317-06018	B - 2	93210-35537	B - 9	94701-00333	B - 2		D - 5
90215-06184	B - 2	90462-08224	B - 13	91317-06020	B - 9	93210-48364	C - 3	95024-06014	C - 11	97007-06016	C - 9
90215-08160	D - 11	90462-08225	B - 13		B - 12	93210-54175	B - 8	95024-08050	D - 2	97007-06020	D - 7
90215-14186	C - 3		B - 14		E - 3	93210-55669	E - 4	95027-06008	E - 12		D - 14
90215-14205	B - 5	90464-06214	D - 12	91317-06025	B - 7	93210-57634	B - 2	95027-06016	E - 12	97007-06025	D - 5
	C - 3	90464-13004	E - 13		E - 3	93210-72529	B - 3	95027-06020	B - 2		D - 13
90240-06076	D - 14	90464-13073	D - 6	91317-06030	B - 3	93211-05471	B - 2	95027-06025	B - 8		E - 8
90240-07083	B - 4	90465-08020	B - 13	91317-08016	B - 12	93306-20201	C - 5		B - 14	97027-06016	B - 7
90240-12075	C - 15	90465-08127	B - 13	91317-08020	C - 2	93306-20203	D - 8		E - 12	97027-06020	C - 8
90249-12008	D - 14	90465-08364	B - 14	91317-08025	B - 12	93306-20313	C - 6	95027-06030	B - 13	97027-08030	B - 15
90267-40075	C - 13	90465-10098	E - 12	91317-08045	B - 2	93306-20332	C - 5	95027-06035	B - 14	97702-40630	E - 6
90280-05013	B - 5	90465-16187	B - 14	91401-20012	D - 14	93306-20348	D - 10	95027-06040	B - 13	97706-40620	E - 5
90282-05013	B - 5	90467-09006	D - 5	91401-25015	D - 14	93306-20401	C - 5	95027-06045	B - 14	97707-40620	E - 5
90282-05043	C - 3	90467-10008	D - 6	91401-30025	C - 15	93306-20580	C - 5	95027-06085	B - 13	97707-50520	B - 9
90338-08007	B - 9	90467-10041	B - 9	91701-06032	D - 15	93306-30427	B - 4	95027-06090	B - 13	97801-05010	B - 10
90338-12081	C - 10	90467-11106	B - 9	91701-08038	D - 14	93306-30611	B - 4	95307-05600	D - 2	98501-04012	E - 6
90338-12192	C - 11		D - 6	92017-08016	D - 15	93310-530J3	B - 4	95307-06600	C - 3	98502-04012	E - 6
90338-18014	B - 15	90467-14015	B - 13	92907-04600	D - 13	93315-23607	C - 7		D - 10	98507-03008	D - 5
90340-14117	B - 14	90468-26122	B - 15	92907-05100	E - 4	93410-20038	C - 5	95307-06700	D - 14	98507-04018	D - 13
90340-32080	B - 14	90480-01141	C - 13		E - 11	93410-22039	C - 5	95307-12700	E - 5	98507-05008	E - 4
90380-12051	C - 15	90480-12053	C - 11	92907-05600	D - 2	93420-28055	C - 4		E - 6	98507-05018	D - 2
90380-18139	C - 14		E - 2	92907-06100	D - 7	93440-10085	B - 2	95607-05200	C - 11		E - 11
90386-14103	C - 3	90480-12299	C - 9	92907-06200	C - 3	93450-17044	B - 4	95607-06100	E - 9	98507-05020	D - 12
90386-18146	C - 14	90480-13197	C - 13		D - 14	93505-16006	C - 3		E - 10		E - 11
90387-063E6	E - 8	90480-14023	E - 8	92907-06600	B - 7	93507-32009	B - 15		E - 11	98507-05025	D - 12
90387-063G3	D - 5	90480-15342	D - 5		B - 12	93602-13177	B - 4	95607-14100	D - 8	98507-05030	E - 11
90387-06681	C - 11	90501-04596	C - 2		C - 9	93603-12030	B - 8	95617-10100	C - 15	98507-06010	B - 12
90387-06737	C - 14	90501-07629	B - 4		D - 5	93604-10011	B - 7	95707-05500	E - 9		C - 6
90387-125F1	B - 13	90501-10245	D - 14		D - 13	93604-16092	C - 7		E - 10	98707-06030	B - 8
90387-125Y0	B - 15	90501-10312	E - 11	92907-08600	B - 12	93604-20156	C - 7		E - 13	98901-04006	B - 11
90387-15600	D - 8	90501-12081	B - 15	93101-15101	C - 5	93605-10090	B - 4	95807-06012	D - 2	98907-06010	B - 12
90387-171T1	D - 10	90501-18576	B - 8	93102-12106	C - 8	93608-50158	C - 8		D - 13	99001-10600	C - 8
90387-171T2	D - 11	90501-21133	B - 4	93102-14209	C - 3	93615-12088	C - 2		E - 13	99009-17400	B - 15
90387-255F3	B - 7	90501-23700	C - 3	93102-17187	C - 6	93700-06009	C - 14	95807-06016	E - 9		C - 5
90401-10159	D - 13	90506-08227	C - 8	93102-17263	B - 15	93823-14149	C - 5		E - 10	99247-00080	C - 11
90430-06014	B - 2	90506-15260	D - 10	93102-20281	D - 8	94113-184R7	D - 8	95807-06020	C - 11	99247-00100	E - 2

NUMERICAL INDEX

PART NO.	GRID NO.	PART NO.	GRID NO.	PART NO.	GRID NO.	PART NO.	GRID NO.	PART NO.	GRID NO.
99530-12016	B - 13								
	B - 14								
99530-14016	B - 2								
	B - 3								