



PARTS CATALOGUE

TW200'10 (10DG) SOUTH AFRICA



1J10D-100E1

()

TW200Z/TW200
PARTS CATALOGUE
©2009 by Yamaha Motor Co., Ltd.
1st edition, June 2009
All rights reserved.
Any reprinting or unauthorized use
without the written permission of
Yamaha Motor Co., Ltd.
is expressly prohibited.
Printed in Japan.

FOREWORD

This Parts Catalogue is related to the parts for the model(s) on the cover page. When you are ordering replacement parts, please refer to this Parts Catalogue and quote both part numbers and part names correctly.

1. Modifications or additions which have been made after the issue of the Parts Catalogue will be announced in the Parts News.

It is advisable that you make the necessary corrections to the Parts Catalogue according to the Parts News.

2. Abbreviations

The following abbreviations are used in this Parts Catalogue.

“UR” Use specified parts number.

“UN” Use as many as needed.

“AP” Alternate Parts

“LM” Locally Made (Parts need to be ordered locally)

“F#” Frame No. (Applicable machine No.)

“O/S” Over Size

3. The number of components for assembly

- Parts, which are to be supplied in an assembly, are listed with a dot (.) in front of the part name as shown below.
- The numeral appearing to the right of each component part indicates the quantity of parts for each assembly unit.

PART NO.	DESCRIPTION	Q'TY	REMARKS
2F5-83310-60	FRONT FLASHER LIGHT ASSY	2	
115-83311-60	.BULB (6V-18W)	1	

4. Applicable colours of graphics are represented in the “REMARKS” as shown below.

PART NO.	DESCRIPTION	Q'TY	REMARKS
2N4-24110-00-X5	FUEL TANK COMP.	2	MXR
3J1-24240-10	.GRAPHIC, FUEL TANK	1	FOR MXR

5. Note that the illustrations for reference in finding parts numbers are not to be used for assembling. When assembling, please use the applicable service manual.

6. The asterisk (*) before a reference number indicates modified items after the first edition.

FOREWORD

7. Applicable Serial No.

Engine Serial No.

Frame Serial No.

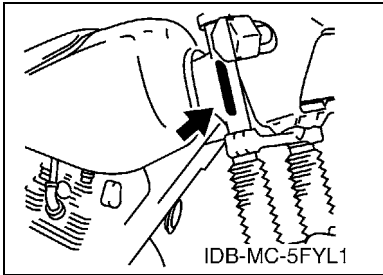
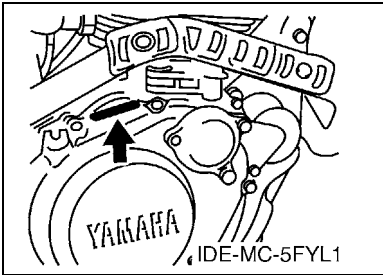

8. Applicable Colour Code (The (*) mark shows Model colour.)

Abbreviation	Colour Name	Colour Code
LGB	LOW GLOSS BLACK	0098
LRY51	LIGHT REDDISH YELLOW SOLID 1	0386
PWS1(*)	PURPLISH WHITE SOLID 1	0206
S8	SILVER 8	0895
SL	SILVER	0035
ZK	*UNI-CHROME (BLACK CHROMATE)	0090

CONTENTS

ENGINE

CYLINDER HEAD	1
CYLINDER	2
CRANKSHAFT & PISTON	3
VALVE	5
CAMSHAFT & CHAIN	6
OIL PUMP	7
INTAKE	8
CARBURETOR	9
EXHAUST	11
CRANKCASE	12
CRANKCASE COVER 1	13
STARTER	14
CLUTCH	16
TRANSMISSION	18
SHIFT CAM & FORK	20
SHIFT SHAFT	21

CHASSIS

FRAME	22
FENDER	24
SIDE COVER	26
REAR ARM	27
REAR SUSPENSION	28
STEERING	29
FRONT FORK	30
FUEL TANK	32
SEAT	33
FRONT WHEEL	34
FRONT BRAKE CALIPER	35
REAR WHEEL	36
STEERING HANDLE & CABLE	38
FRONT MASTER CYLINDER	39
STAND & FOOTREST	40
COWLING 1	42
GENERATOR	43
STARTING MOTOR	44
FLASHER LIGHT	45
METER	46
HEADLIGHT	47
TAILLIGHT	48
HANDLE SWITCH & LEVER	49

ELECTRICAL 1	50
--------------------	----

INDEX

NUMERICAL INDEX	52
-----------------------	----

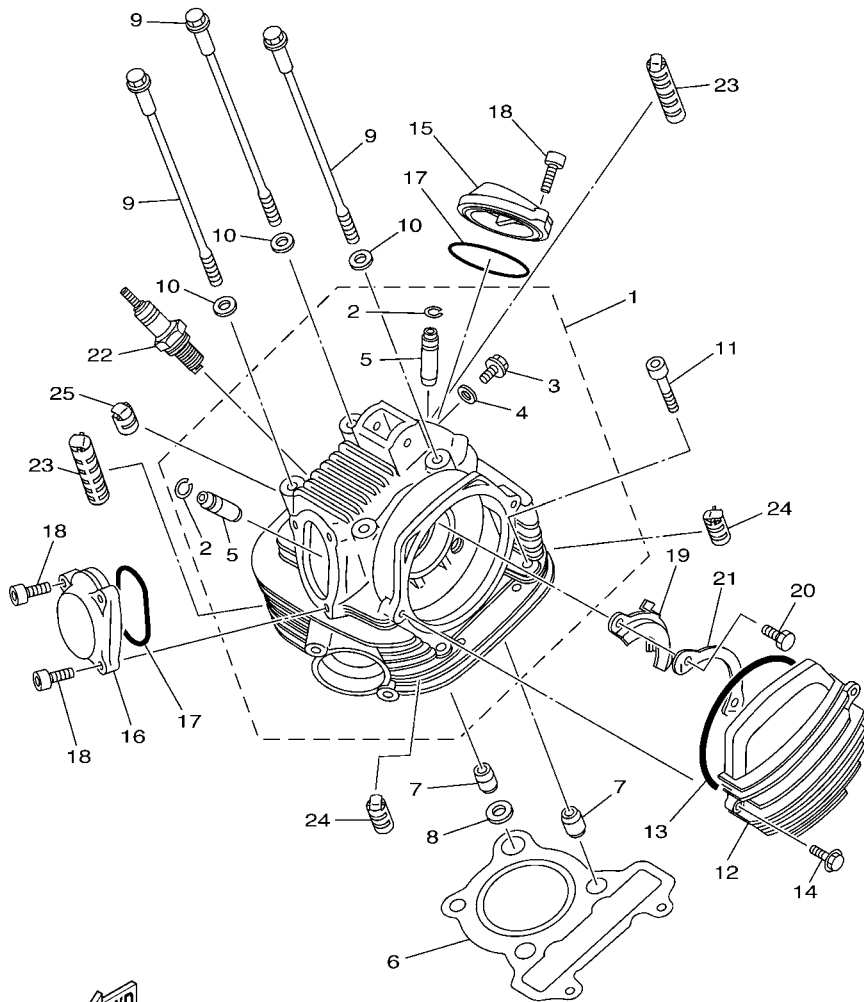

5FY8100-1010

FIG. 1 CYLINDER HEAD

REF. NO.	PART NO.	DESCRIPTION	10DF	10DG	REMARKS
1	15A-11110-04	CYLINDER HEAD ASSY	1	1	
2	93440-10085	.CIRCLIP	2	2	
3	90153-06029	.SCREW, HEXAGON	1	1	
4	90430-06014	.GASKET	1	1	
5	5H0-11133-11	.GUIDE, VALVE 1	2	2	
6	1NU-11181-00	GASKET, CYLINDER HEAD 1	1	1	
7	99530-14016	PIN, DOWEL	3	3	
8	90430-14131	GASKET	1	1	
9	90105-08117	BOLT, FLANGE	4	4	
10	90201-08609	WASHER, PLATE	4	4	
11	91317-08045	BOLT	2	2	
12	15A-11185-00	COVER, CYLINDER HEAD SIDE 3	1	1	
13	93211-05471	O-RING	1	1	
14	95027-06020	BOLT, FLANGE	2	2	
15	15A-11186-00	COVER, CYLINDER HEAD SIDE 2	1	1	
16	15A-11187-00	COVER, CYLINDER HEAD SIDE 3	1	1	
17	93210-57634	O-RING	2	2	
18	91317-06018	BOLT	5	5	
19	5H0-1111F-00	PLATE	1	1	
20	97007-06012	BOLT	2	2	
21	90215-06184	WASHER, LOCK	1	1	
22	94701-00333	PLUG, SPARK (NGK DR8EA)	1	1	UR
	94701-00222	PLUG, SPARK (ND X24ESR-U)	1	1	UR
23	15A-11162-00	ABSORBER 2	2	2	
24	5H0-11162-00	ABSORBER 2	2	2	
25	15A-11161-01	ABSORBER 1	1	1	

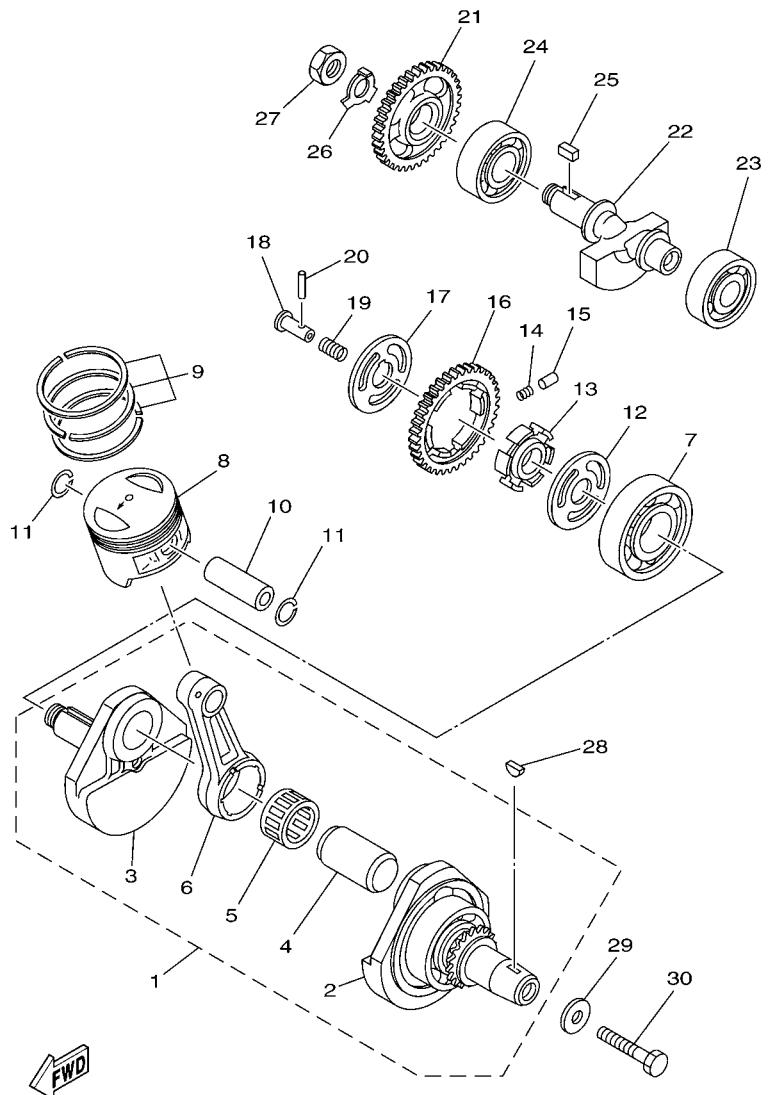

5FY5100-0030

FIG. 3 CRANKSHAFT & PISTON

REF. NO.	PART NO.	DESCRIPTION	10DF	10DG		REMARKS
1	5H0-11400-01	CRANKSHAFT ASSY	1	1		
2	5H0-11412-09	.CRANK 1	1	1		
3	5H0-11422-00	.CRANK 2	1	1		
4	5H0-11681-00	.PIN, CRANK 1	1	1		
5	93310-530J3	.BEARING	1	1		
6	15A-11651-00	.ROD, CONNECTING	1	1		
7	93306-30611	BEARING	1	1		
8	36X-11631-00-A0	PISTON (STD)	1	1		
	36X-11636-00	PISTON (0.50MM O/S)	1	1		AP
	36X-11638-00	PISTON (1.00MM O/S)	1	1		AP
9	15A-11603-00	PISTON RING SET (STD)	1	1		
	15A-11605-00	PISTON RING SET (0.50MM O/S)	1	1		AP
	15A-11607-00	PISTON RING SET (1.00MM O/S)	1	1		AP
10	15A-11633-00	PIN, PISTON	1	1		
11	93450-17044	CIRCLIP	2	2		
12	90201-201E4	WASHER, PLATE	1	1		
13	5H0-11496-00	BOSS, BUFFER	1	1		
14	90501-21133	SPRING, COMPRESSION	6	6		
15	93605-10090	PIN, DOWEL	3	3		
16	5H0-11536-00	GEAR, DRIVE (38T)	1	1		
17	90214-20023	WASHER, CLAW	1	1		
18	90240-07083	PIN, CLEVIS	1	1		
19	90501-07629	SPRING, COMPRESSION	1	1		
20	93602-13177	PIN, DOWEL	1	1		
21	5H0-11531-00	GEAR, BALANCE WEIGHT (38T)	1	1		
22	15A-11454-00	WEIGHT 1	1	1		
23	93306-30427	BEARING	1	1		



5H0110-0040

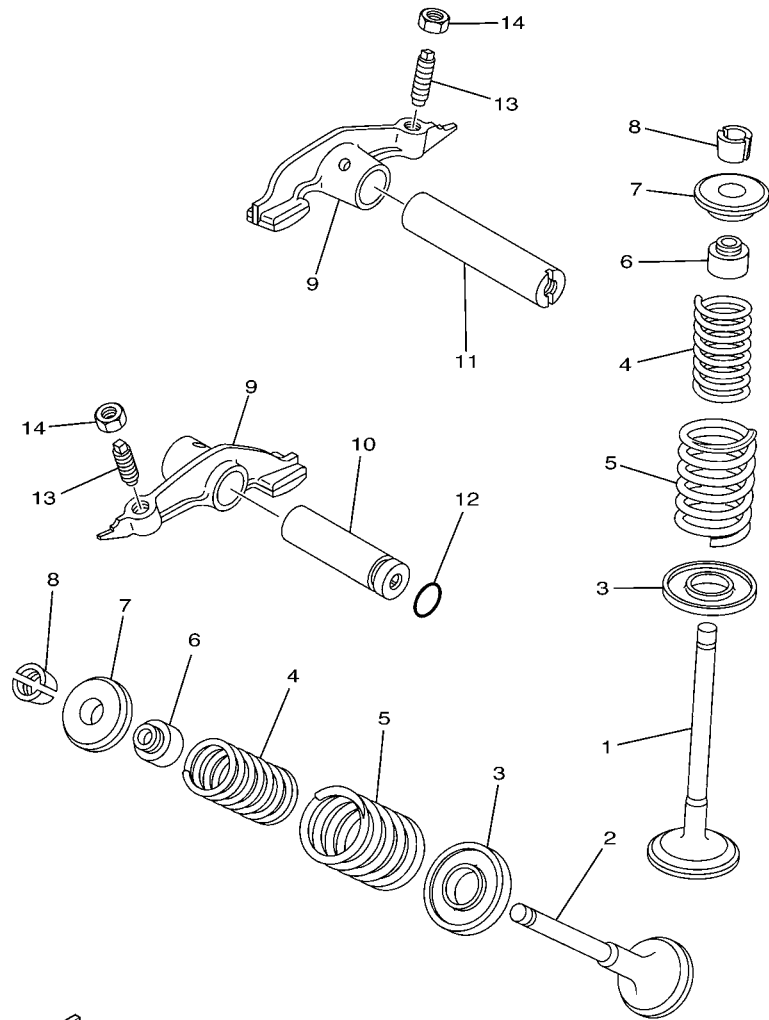
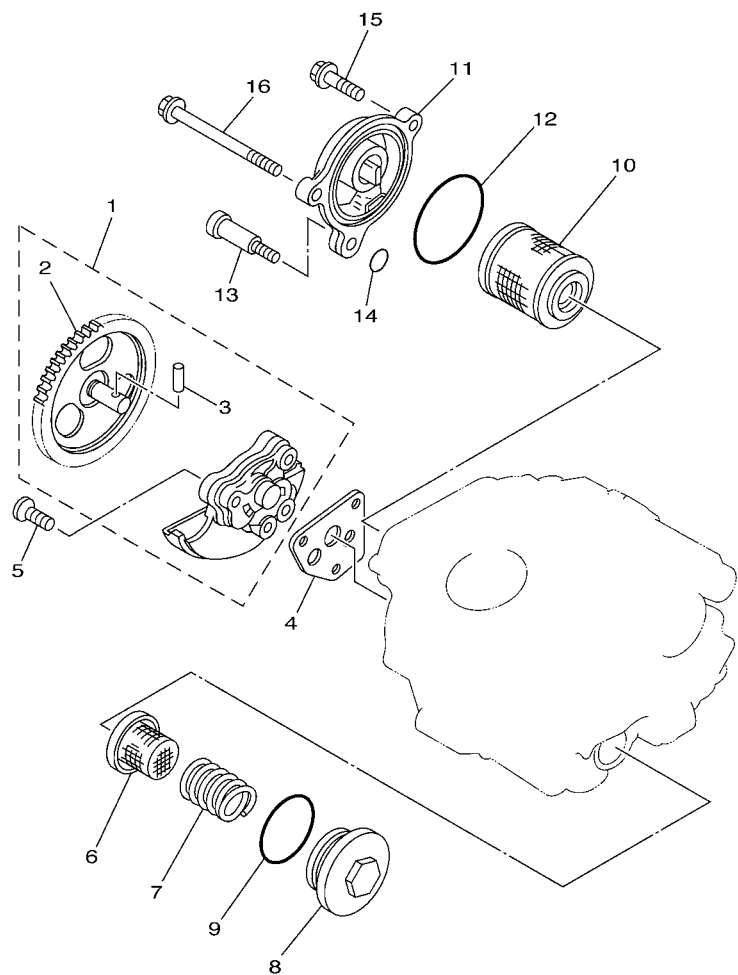

FIG. 4 VALVE

REF. NO.	PART NO.	DESCRIPTION	10DF	10DG	REMARKS
1	5H0-12111-02	VALVE, INTAKE	1	1	
2	5H0-12121-01	VALVE, EXHAUST	1	1	
3	4G0-12116-01	SEAT, VALVE SPRING	2	2	
4	11H-12113-00	SPRING, VALVE INNER	2	2	
5	11H-12114-00	SPRING, VALVE OUTER	2	2	
6	5H0-12119-00	SEAL, VALVE STEM	2	2	
7	4G0-12117-00	RETAINER, VALVE SPRING	2	2	
8	4G0-12118-00	COTTER, VALVE	4	4	
9	36X-12151-00	ARM, VALVE ROCKER	2	2	
10	5H0-12156-00	SHAFT, ROCKER 2	1	1	
11	5H0-12146-00	SHAFT, ROCKER	1	1	
12	93210-09165	O-RING	1	1	
13	2NX-12159-00	SCREW, VALVE ADJUSTING	2	2	
14	90170-06128	NUT	2	2	

FIG. 6 OIL PUMP



5FY8100-1060

REF. NO.	PART NO.	DESCRIPTION	10DF	10DG	REMARKS
1	5H0-13300-02	OIL PUMP ASSY	1	1	
2	5H0-13326-01	.GEAR, PUMP DRIVEN 2 (45T)	1	1	
3	93603-12030	.PIN, DOWEL	1	1	
4	4BE-13329-01	GASKET, PUMP COVER	1	1	
5	98707-06030	SCREW, FLAT HEAD	3	3	
6	51Y-13411-00	STRAINER, OIL	1	1	
7	90501-18576	SPRING, COMPRESSION	1	1	
8	5H0-15351-00	PLUG, DRAIN	1	1	
9	93210-347A1	O-RING	1	1	
10	5H0-13440-09	ELEMENT ASSY, OIL CLEANER	1	1	
11	15A-13447-00	COVER, OIL ELEMENT	1	1	
12	93210-54175	O-RING	1	1	
13	90109-06419	BOLT	1	1	
14	93210-07135	O-RING	1	1	
15	95027-06025	BOLT, FLANGE	1	1	
16	90105-065A1	BOLT, FLANGE	1	1	

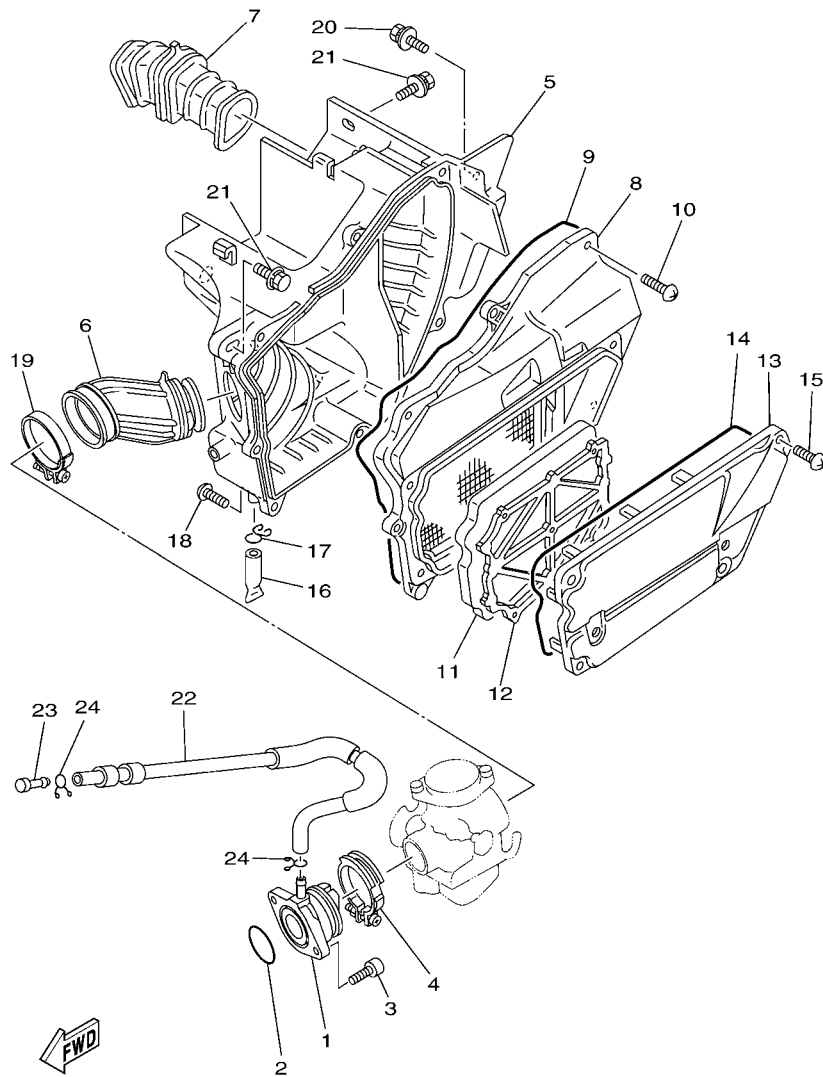

10DD110-J070

FIG. 7 INTAKE

REF. NO.	PART NO.	DESCRIPTION	10DF	10DG		REMARKS
1	5LB-13586-02	JOINT, CARBURETOR 1	1	1		
2	93210-35537	O-RING	1	1		
3	91317-06020	BOLT	2	2		
4	90450-44062	HOSE CLAMP ASSY	1	1		
5	2JX-14411-02	CASE, AIR CLEANER 1	1	1		
6	5LB-14453-10	JOINT, AIR CLEANER 1	1	1		
7	2JL-14437-00	DUCT	1	1		
8	2JX-14412-00	CAP, CLEANER CASE 1	1	1		
9	2JX-14452-00	SEAL	1	1		
10	97707-50520	SCREW, TAPPING	5	5		
11	2JX-14451-00	ELEMENT, AIR CLEANER	1	1		
12	2JX-14458-00	GUIDE	1	1		
13	2JX-14422-00	CAP, CLEANER CASE 2	1	1		
14	5U8-14457-00	SEAL	1	1		
15	90154-05005	SCREW, BINDING	4	4		
16	34X-1443E-00	PIPE, DRAIN	1	1		
17	90467-11106	CLIP	1	1		
18	97702-50525	SCREW, TAPPING	2	2		
19	90460-51059	CLAMP, HOSE	1	1		
20	90119-06056	BOLT, WITH WASHER	1	1		
21	90119-06063	BOLT, WITH WASHER	2	2		
22	5LB-13584-00	PIPE, INTAKE MANIFOLD	1	1		
23	90338-08007	PLUG	1	1		
24	90467-10041	CLIP	2	2		

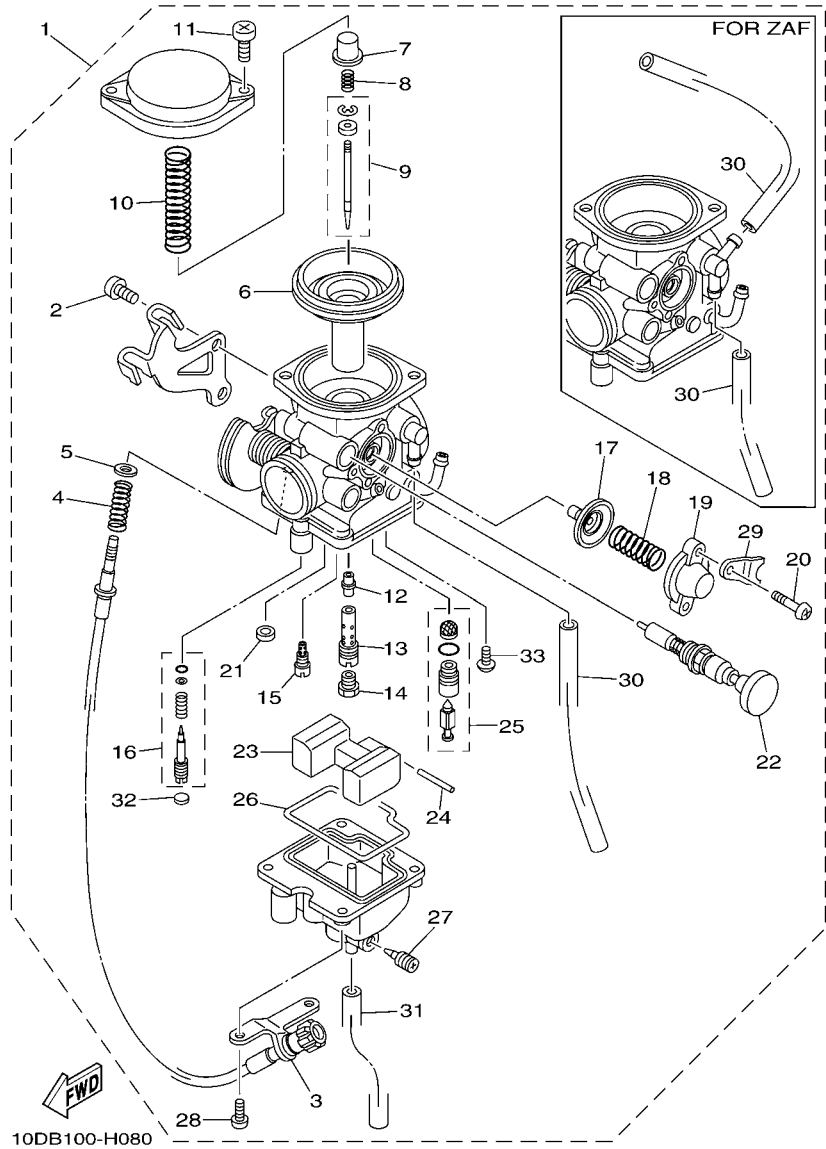
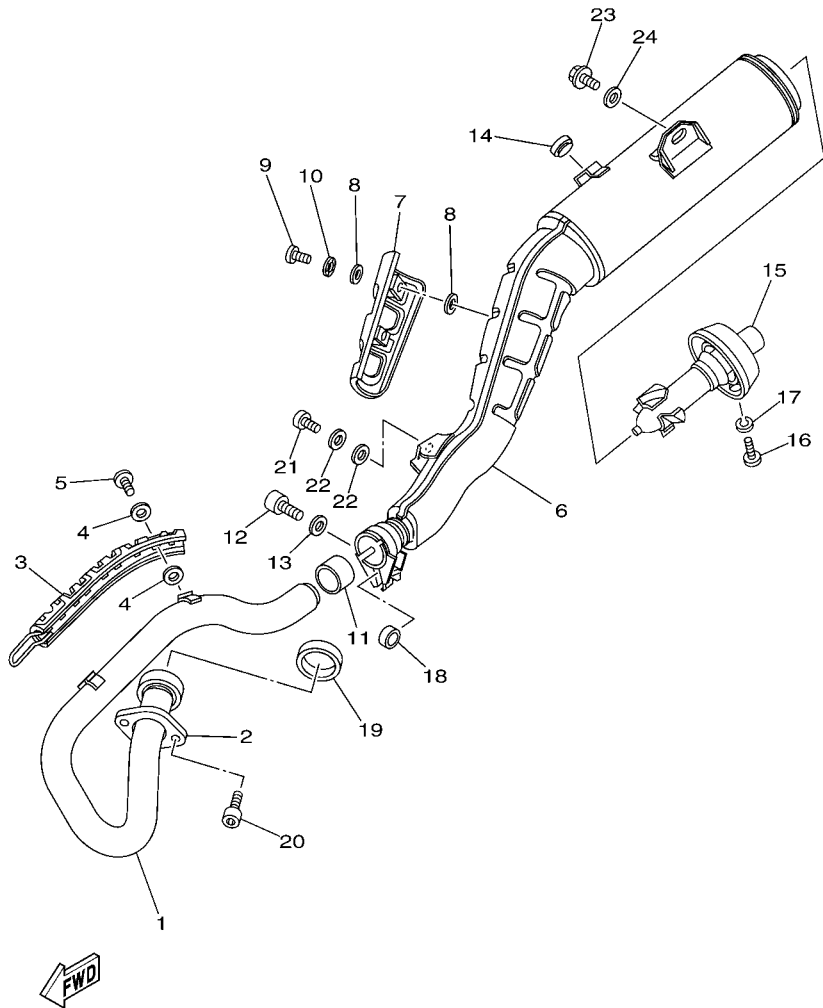

FIG. 8 CARBURETOR

REF. NO.	PART NO.	DESCRIPTION	10DF	10DG	REMARKS
1	5LB-14301-01	CARBURETOR ASSY 1	1	1	
2	97801-05010	.THROTTLE SCREW	2	2	
3	5LB-14321-00	.SCREW, THROTTLE	1	1	
4	2JX-14333-00	.SPRING, THROTTLE STOP	1	1	
5	5LB-14357-00	.WASHER, PLAIN	1	1	
6	5LB-1434A-00	.SUCTION PISTON ASSY	1	1	
7	5LB-14936-00	.SEAT, SPRING	1	1	
8	5LB-14275-00	.SPRING	1	1	
9	5LB-14336-00	.NEEDLE	1	1	
10	5LB-14286-00	.SPRING	1	1	
11	5LB-14216-00	.SCREW	2	2	
12	5LB-14341-00	.NOZZLE, MAIN	1	1	
13	5LB-14341-10	.BLEED, MAIN NOZZLE	1	1	
14	288-14343-66	.JET, MAIN (#132)	1	1	
15	5LB-14342-65	.JET, PILOT (#31)	1	1	
16	5LB-14105-00	.PILOT SCREW SET	1	1	
17	5LB-14368-00	.DIAPHRAGM ASSY 1	1	1	
18	5LB-14589-00	.SPRING	1	1	
19	5LB-14293-00	.COVER 1	1	1	
20	214-24535-00	.SCREW, LEVER FITTING	2	2	
21	50M-14355-00	.PLUG	1	1	
22	5FY-14371-00	.PLUNGER, STARTER	1	1	
23	5LB-14385-00	.FLOAT	1	1	
24	5LB-14386-00	.PIN, FLOAT	1	1	



10DD110-J090

FIG. 9 EXHAUST

REF. NO.	PART NO.	DESCRIPTION	10DF	10DG		REMARKS
1	2JX-14611-02	PIPE, EXHAUST 1	1	1		
2	5H0-14612-01	NUT, RING	1	1		
3	5LB-14628-00	PROTECTOR, EXHAUST PIPE	1	1		
4	90201-05015	WASHER, PLATE	4	4		
5	98907-06010	SCREW, BIND	2	2		
6	2JL-14711-21	MUFFLER 1	1	1		
7	2JX-14728-00	PROTECTOR, MUFFLER 2	1	1		
8	90202-05191	WASHER, PLATE	4	4		
9	98907-06010	SCREW, BIND	2	2		
10	90206-06090	WASHER, WAVE	2	2		
11	3YF-14714-00	GASKET, MUFFLER	1	1		
12	91317-08025	BOLT	1	1		
13	92907-08600	WASHER, PLATE	1	1		
14	22W-24181-00	DAMPER, LOCATING 1	1	1		
18	90387-080K1	COLLAR	1	1		
19	4BE-14613-00	GASKET, EXHAUST PIPE	1	1		
20	91317-06020	BOLT	2	2		
21	91317-08020	BOLT	1	1		
22	90201-08326	WASHER, PLATE	2	2		
23	95817-08016	BOLT, FLANGE	1	1		
24	90201-08326	WASHER, PLATE	1	1		

FIG. 10 CRANKCASE

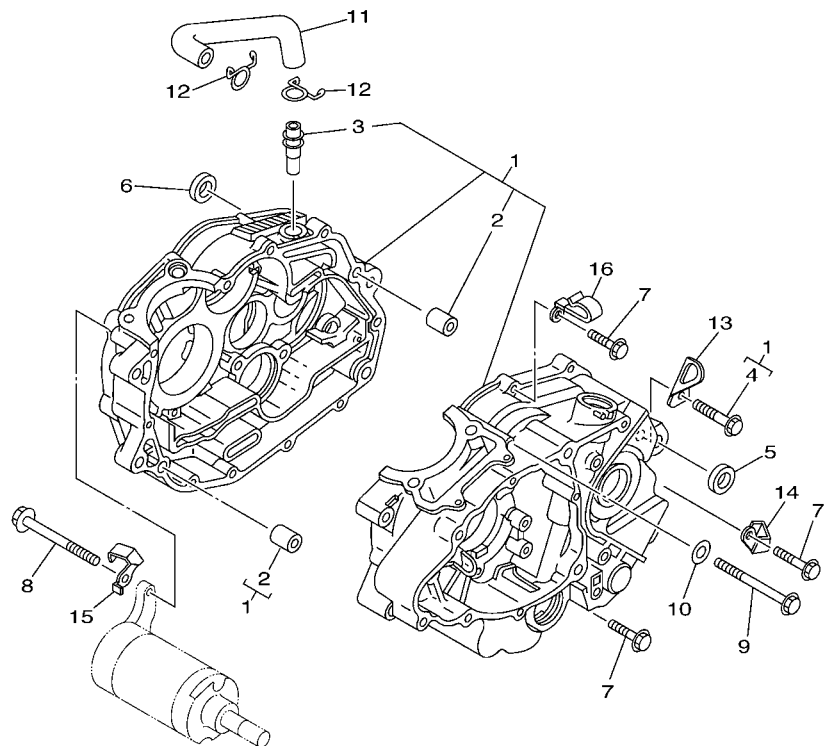

5FY8100-1100

REF. NO.	PART NO.	DESCRIPTION	10DF	10DG	REMARKS
1	1RL-15100-03	CRANKCASE ASSY	1	1	
2	99530-12016	.PIN, DOWEL	2	2	
3	371-11167-01	.PIPE, BREATHER 2	1	1	
4	95027-06040	.BOLT, FLANGE	2	2	
5	90387-125F1	COLLAR	1	1	
6	90387-125F1	COLLAR	1	1	
7	95027-06030	BOLT, FLANGE	7	7	
8	95027-06090	BOLT, FLANGE	2	2	
9	95027-06085	BOLT, FLANGE	1	1	
10	90430-06014	GASKET	1	1	
11	3Y1-11166-00	PIPE, BREATHER 1	1	1	
12	90467-14015	CLIP	2	2	
13	90465-08020	CLAMP	1	1	
14	90462-08225	CLAMP	1	1	
15	90462-08224	CLAMP	1	1	
16	90465-08127	CLAMP	1	1	

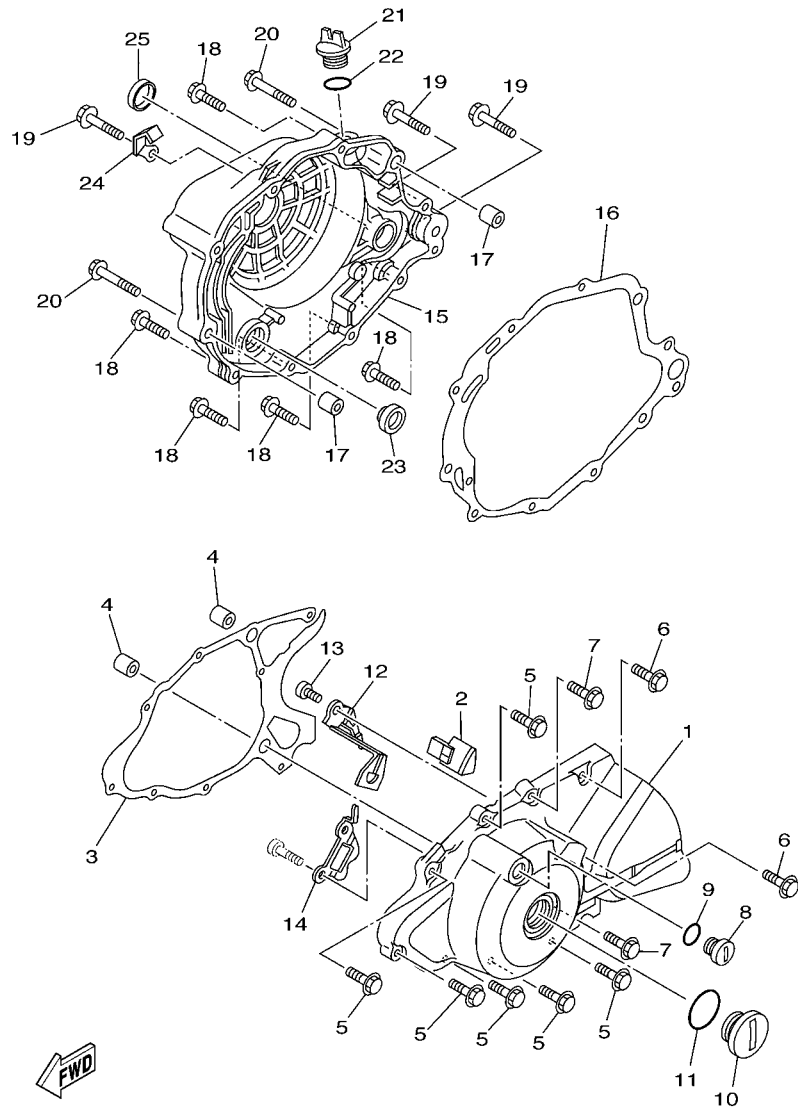

5FY8100-1110

FIG. 11 CRANKCASE COVER 1

REF. NO.	PART NO.	DESCRIPTION	10DF	10DG		REMARKS
1	5EK-15410-00	CRANKCASE COVER ASSY 1	1	1		
2	2JX-15377-00	GUIDE, INLET	1	1		
3	3AW-15451-03	GASKET, CRANKCASE COVER 1	1	1		
4	99530-12016	PIN, DOWEL	2	2		
5	95027-06025	BOLT, FLANGE	6	6		
6	90105-06017	BOLT, FLANGE	2	2		
7	90105-06014	BOLT, FLANGE	2	2		
8	90340-14117	PLUG, STRAIGHT SCREW	1	1		
9	93210-14369	O-RING	1	1		
10	90340-32080	PLUG, STRAIGHT SCREW	1	1		
11	93210-32172	O-RING	1	1		
12	90465-08364	CLAMP	1	1		
13	91317-06010	BOLT	1	1		
14	90465-16187	CLAMP	1	1		
15	15A-15431-01	COVER, CRANKCASE 3	1	1		
16	4BE-15462-00	GASKET, CRANKCASE COVER 3	1	1		
17	99530-12016	PIN, DOWEL	2	2		
18	95027-06025	BOLT, FLANGE	5	5		
19	95027-06035	BOLT, FLANGE	3	3		
20	95027-06045	BOLT, FLANGE	2	2		
21	3Y1-15363-10	PLUG, OIL	1	1		
22	93210-19123	O-RING	1	1		
23	3Y1-15361-00	GAUGE, LEVEL	1	1		
24	90462-08225	CLAMP	1	1		

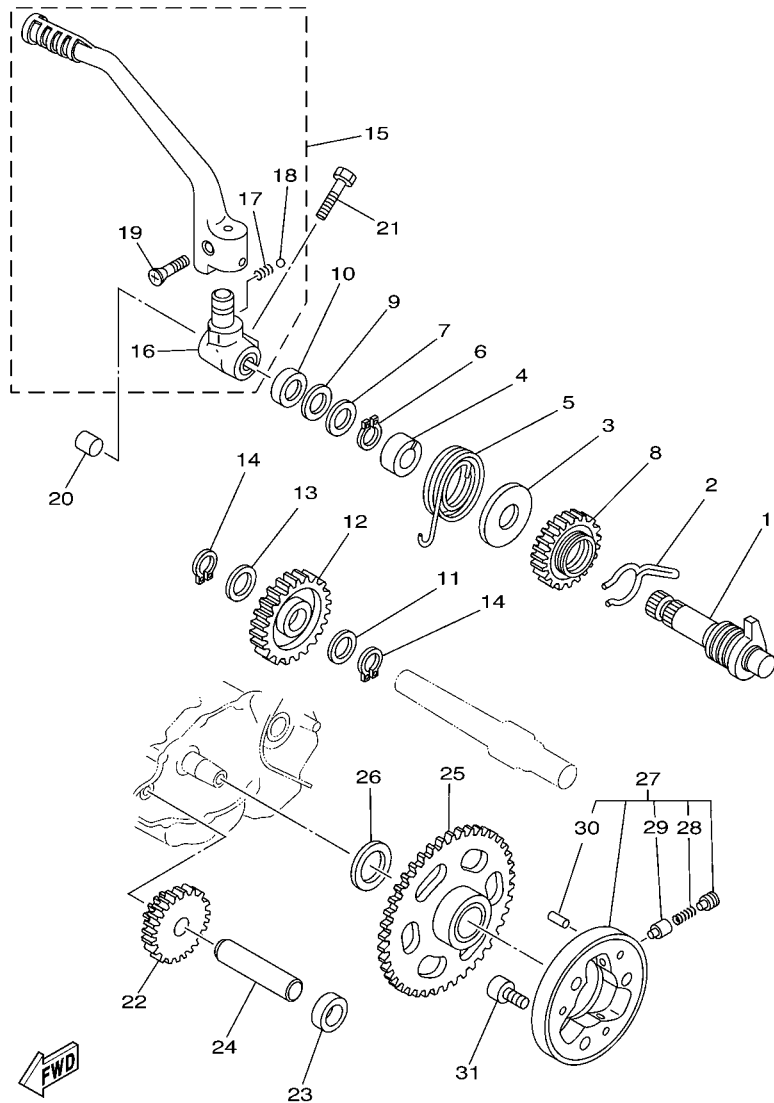

5LB1010-0141

FIG. 12 STARTER

REF. NO.	PART NO.	DESCRIPTION	10DF	10DG	REMARKS
1	15A-15660-01	KICK AXLE ASSY		1	
2	90468-26122	CLIP		1	
3	401-15676-00	COVER, SPRING		1	
4	15A-15666-00	SPACER		1	
5	90508-26538	SPRING, TORSION		1	
6	99009-17400	CIRCLIP		1	
7	90201-175F6	WASHER, PLATE		1	
8	36X-15641-00	GEAR, KICK (27T)		1	
9	90209-17226	WASHER		1	
10	93102-17263	OIL SEAL		1	
11	90201-173F4	WASHER, PLATE		1	
12	15A-15651-01	GEAR, KICK IDLE (28T)		1	
13	90214-17028	WASHER, CLAW		1	
14	99009-17400	CIRCLIP		2	
15	54G-15620-01	KICK CRANK ASSY		1	
16	54G-15621-00	.BOSS, KICK CRANK		1	
17	90501-12081	.SPRING, COMPRESSION		1	
18	93507-32009	.BALL		1	
19	90152-06010	.SCREW, COUNTERSUNK		1	
20	90338-18014	PLUG		1	
21	97027-08030	BOLT, HEXAGON		1	
22	2HT-15512-00	GEAR, IDLER 1 (41T/10T)	1	1	
23	90387-125Y0	COLLAR	1	1	
24	5H0-15521-00	SHAFT 1	1	1	
25	5H0-15517-00	GEAR, IDLER 2 (56T)	1	1	
26	90201-25290	WASHER, PLATE	1	1	
27	4H7-15580-10	STARTER CLUTCH OUTER ASSY	1	1	

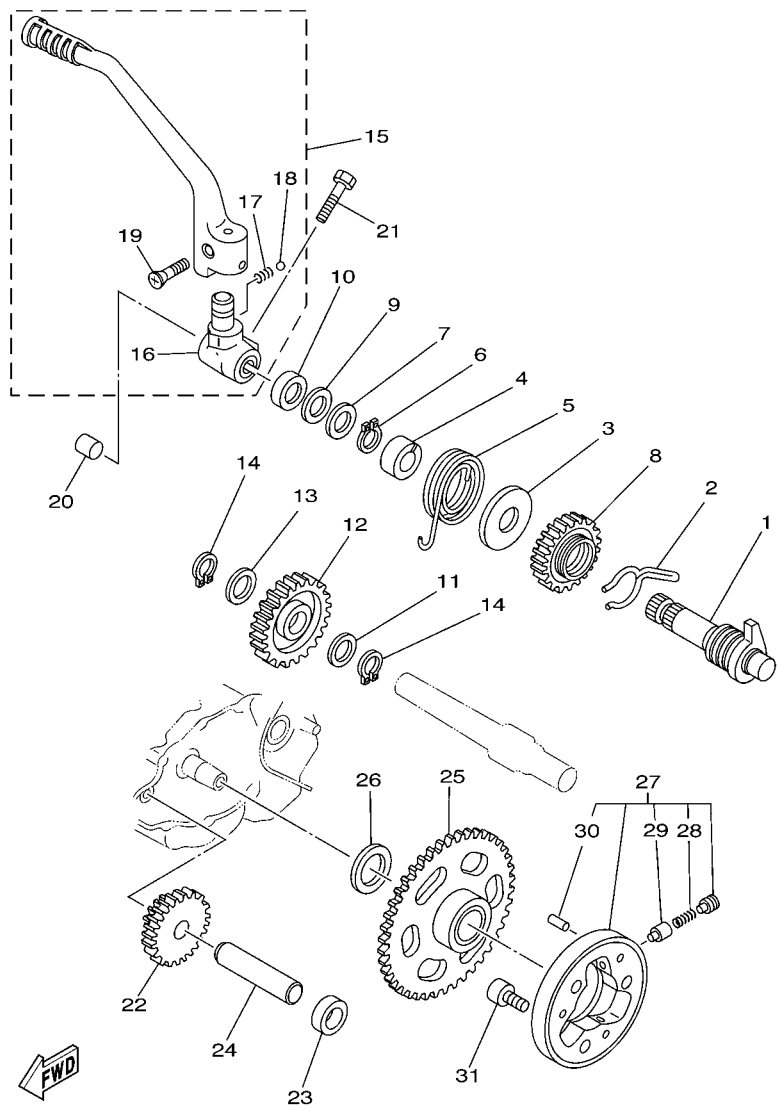

5LB1010-0141

FIG. 12 STARTER

REF. NO.	PART NO.	DESCRIPTION	10DF	10DG		REMARKS
28	90501-04596	.SPRING, COMPRESSION	3	3		
29	1J7-15583-01	.CAP, STARTER CLUTCH SPRING	3	3		
30	93615-12088	.PIN, DOWEL	3	3		
31	91317-08020	BOLT	3	3		

FIG. 13 CLUTCH

REF. NO.	PART NO.	DESCRIPTION	10DF	10DG	REMARKS
1	5H0-16111-00	GEAR, PRIMARY DRIVE (22T)	1	1	
2	90282-05043	KEY, STRAIGHT	1	1	
3	90215-14205	WASHER, LOCK	1	1	
4	90170-14284	NUT	1	1	
5	15A-16150-00	PRIMARY DRIVEN GEAR COMP.73/17	1	1	
6	5H0-16154-00	PLATE, THRUST 1	1	1	
7	2JX-16371-00	BOSS, CLUTCH	1	1	
8	537-16321-00	PLATE, FRICTION	5	5	
9	137-16324-00	PLATE, CLUTCH 1	4	4	
10	5H0-16351-00	PLATE, PRESSURE 1	1	1	
11	90501-23700	SPRING, COMPRESSION	4	4	
12	90159-05011	SCREW, WITH WASHER	4	4	
13	1W1-16358-01	PLATE, PUSH	1	1	
14	2JX-16356-00	ROD, PUSH 1	1	1	
15	93210-48364	O-RING	1	1	
16	92907-06200	WASHER	1	1	
17	95307-06600	NUT	1	1	
18	90215-14186	WASHER, LOCK	1	1	
19	90170-14284	NUT	1	1	
20	15A-16380-00	PUSH LEVER ASSY	1	1	
21	90430-08119	GASKET	1	1	
22	90149-08067	SCREW	1	1	
23	90508-18537	SPRING, TORSION	1	1	
24	5H0-16357-00	ROD, PUSH 2	1	1	
25	93505-16006	BALL	1	1	
26	90386-14103	BUSH	1	1	
27	93102-14209	OIL SEAL	1	1	

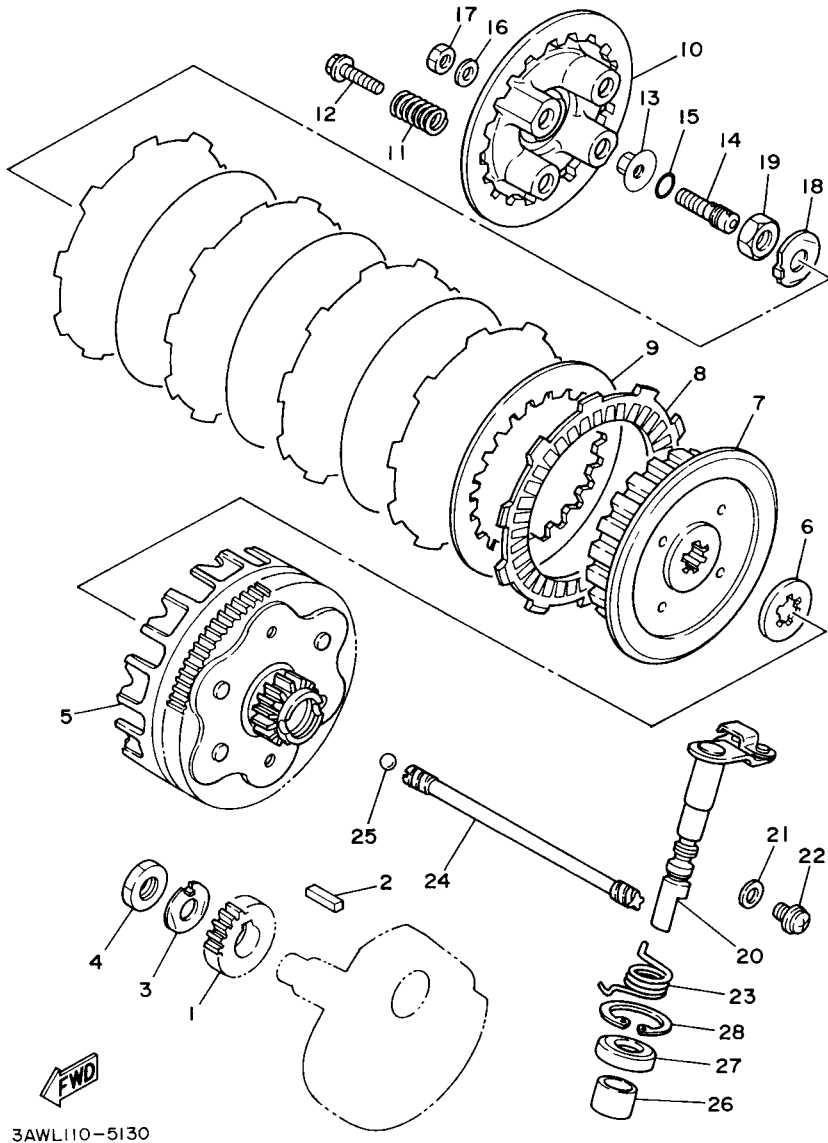

3AWL110-5130

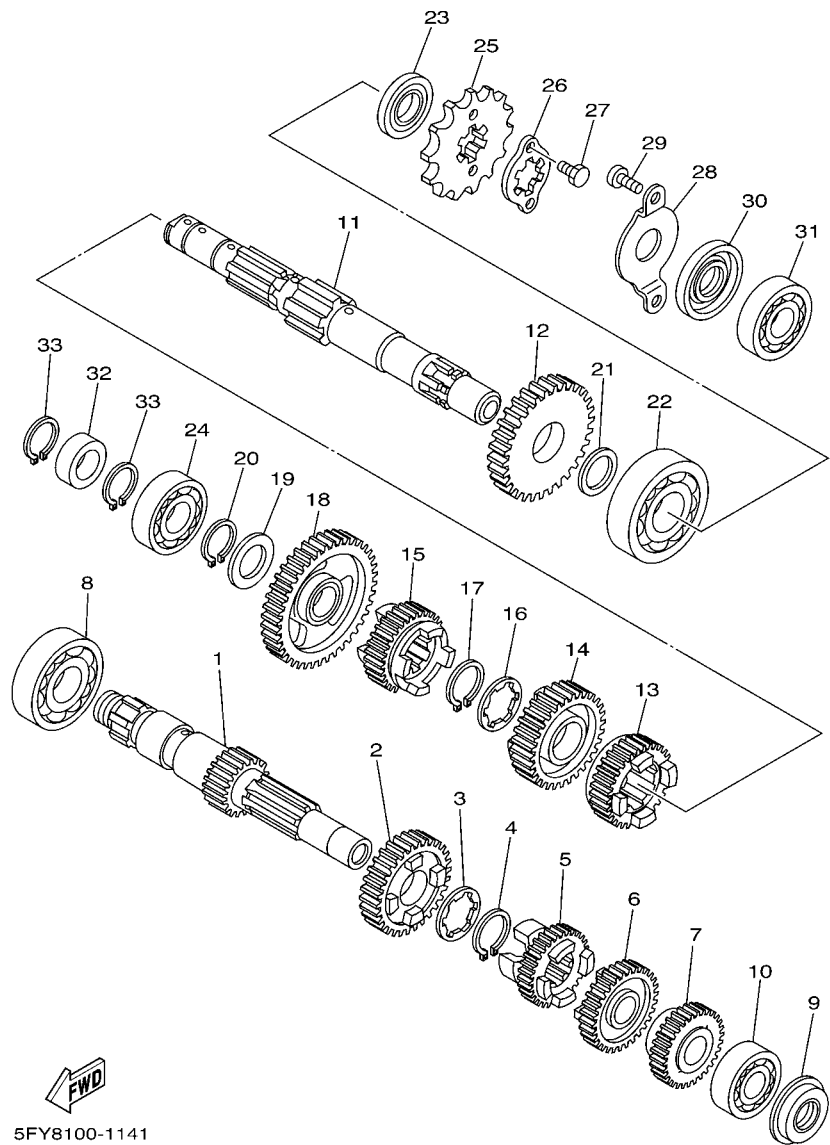

5FY8100-1141

FIG. 14 TRANSMISSION

REF. NO.	PART NO.	DESCRIPTION	10DF	10DG	REMARKS
1	15A-17411-01	AXLE, MAIN (12T)	1	1	
2	15A-17151-01	GEAR, 5TH PINION (28T)	1	1	
3	90209-16209	WASHER	1	1	
4	93410-20038	CIRCLIP	1	1	
5	5H0-17121-01	GEAR, 2ND PINION (22T)	1	1	
6	15A-17141-00	GEAR, 4TH PINION (25T)	1	1	
7	15A-17121-00	GEAR, 2ND PINION (19T)	1	1	
8	93306-20401	BEARING	1	1	
9	93101-15101	OIL SEAL	1	1	
10	93306-20201	BEARING	1	1	
11	2JX-17402-00	DRIVE AXLE ASSY	1	1	
12	15A-17221-00	GEAR, 2ND WHEEL (34T)	1	1	
13	15A-17241-00	GEAR, 4TH WHEEL (26T)	1	1	
14	15A-17231-00	GEAR, 3RD WHEEL (29T)	1	1	
15	1EV-17251-00	GEAR, 5TH WHEEL (23T)	1	1	
16	90209-18208	WASHER	1	1	
17	93410-22039	CIRCLIP	1	1	
18	15A-17211-01	GEAR, 1ST WHEEL (34T)	1	1	
19	90201-17257	WASHER, PLATE	1	1	
20	99009-17400	CIRCLIP	1	1	
21	90201-220J8	WASHER, PLATE	1	1	
22	93306-20580	BEARING	1	1	
23	93102-22389	OIL SEAL	1	1	
24	93306-20332	BEARING	1	1	
25	93823-14149	SPROCKET, DRIVE (14T)	1	1	
26	2JX-17456-00	HOLDER, SPROCKET	1	1	
27	97007-05010	BOLT	2	2	

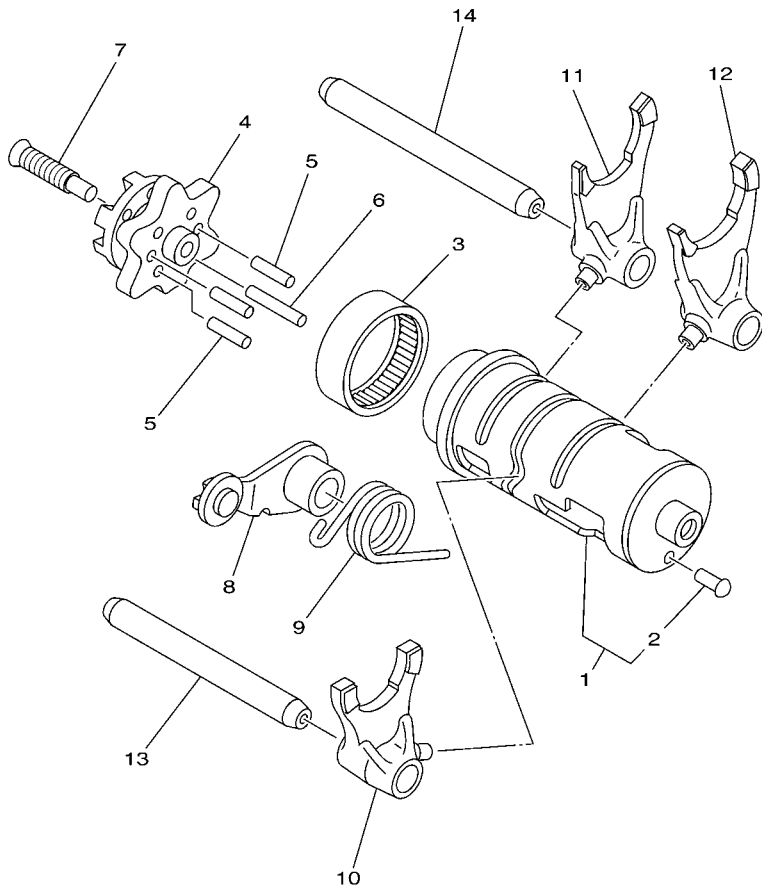

5N0010-0171

FIG. 15 SHIFT CAM & FORK

REF. NO.	PART NO.	DESCRIPTION	10DF	10DG	REMARKS
1	5N0-18540-00	SHIFT CAM ASSY	1	1	
2	136-18542-00	.POINT, NEUTRAL	1	1	
3	93315-23607	BEARING	1	1	
4	1RH-18185-00	SEGMENT	1	1	
5	93604-16092	PIN, DOWEL	3	3	
6	93604-20156	PIN, DOWEL	1	1	
7	90151-06013	SCREW, COUNTERSUNK	1	1	
8	1RH-18140-00	STOPPER LEVER ASSY	1	1	
9	90508-26539	SPRING, TORSION	1	1	
10	4JG-18511-00	FORK, SHIFT 1	1	1	
11	4JG-18512-01	FORK, SHIFT 2	1	1	
12	4JG-18513-00	FORK, SHIFT 3	1	1	
13	3GX-18531-00	BAR, SHIFT FORK GUIDE 1	1	1	
14	3GX-18535-00	BAR, SHIFT FORK GUIDE 2	1	1	

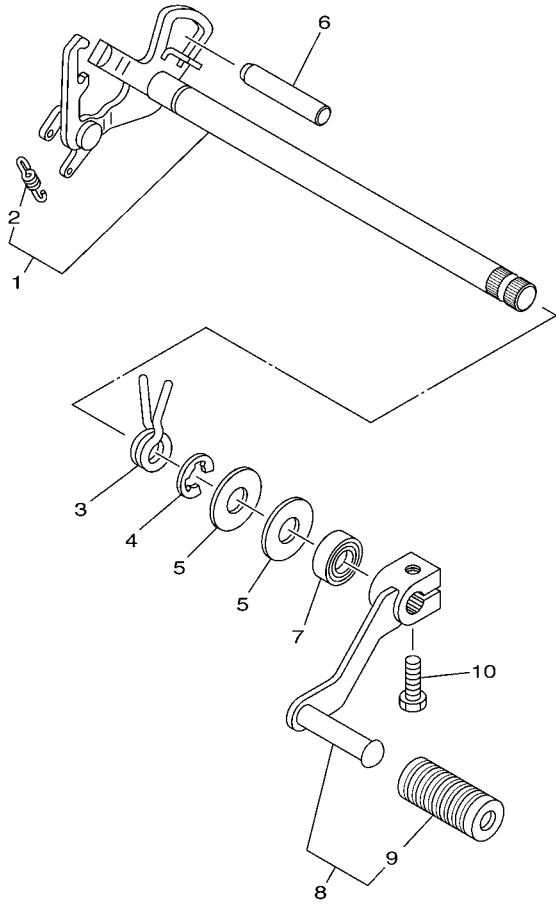

25A310-3171

FIG. 16 SHIFT SHAFT

REF. NO.	PART NO.	DESCRIPTION	10DF	10DG	REMARKS
1	5H0-18120-02	SHIFT LEVER ASSY	1	1	
2	90506-08227	.SPRING, TENSION	1	1	
3	90508-29540	SPRING, TORSION	1	1	
4	99001-10600	CIRCLIP	1	1	
5	90201-12588	WASHER, PLATE	2	2	
6	93608-50158	PIN, DOWEL	1	1	
7	93102-12106	OIL SEAL (SD 12-22-5 HS)	1	1	
8	1RL-18110-00	SHIFT PEDAL ASSY	1	1	
9	132-18113-01	.COVER, SHIFT PEDAL	1	1	
10	97027-06020	BOLT, HEXAGON	1	1	

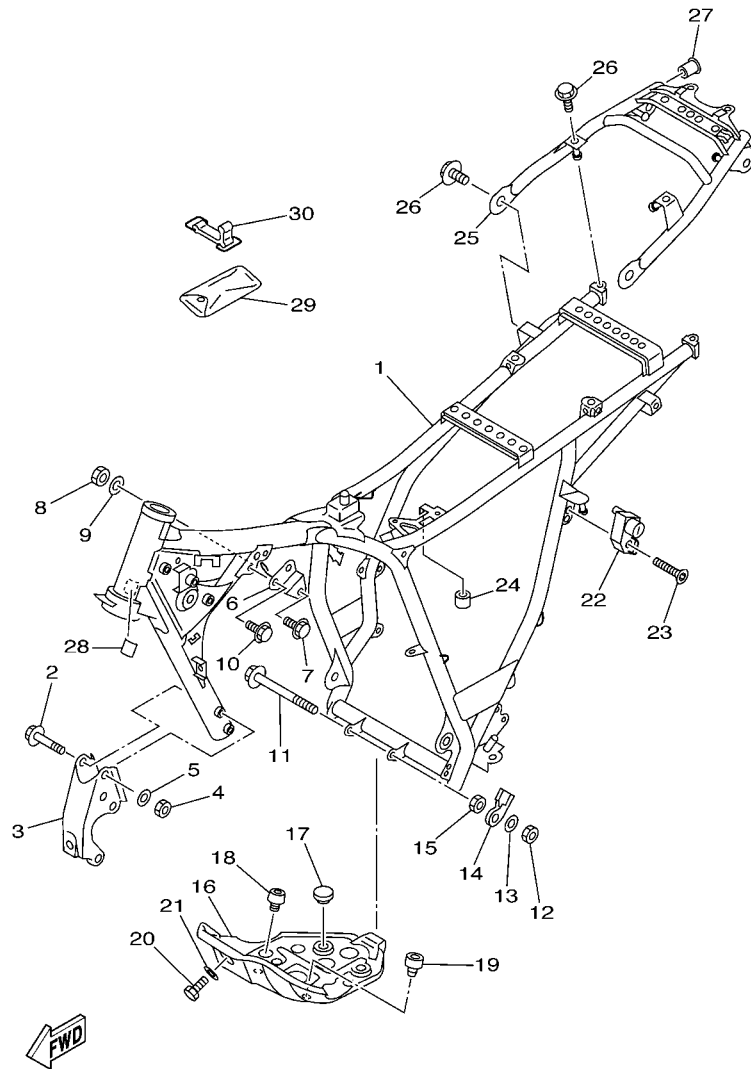

5FYG100-B170

FIG. 17 FRAME

REF. NO.	PART NO.	DESCRIPTION	10DF	10DG	REMARKS
1	5FY-21110-61	FRAME COMP.	1	1	
2	95817-08065	BOLT, FLANGE	4	4	
3	1RL-21316-00-P2	STAY, ENGINE 3	1	1	S8 FOR PWS1
4	90185-08089	NUT, SELF-LOCKING	4	4	
5	90201-08366	WASHER, PLATE	4	4	
6	5VC-21315-00	STAY, ENGINE 2	1	1	
7	95817-08050	BOLT, FLANGE	1	1	
8	90185-08089	NUT, SELF-LOCKING	1	1	
9	90201-08366	WASHER, PLATE	1	1	
10	90105-08066	BOLT, FLANGE	2	2	
11	95817-08120	BOLT, FLANGE	1	1	
12	90185-08089	NUT, SELF-LOCKING	1	1	
13	90201-08366	WASHER, PLATE	1	1	
14	1RL-21337-00	CLAMP, CABLE	1	1	
15	90185-08055	NUT, SELF-LOCKING	1	1	
16	1RL-21471-00-35	PROTECTOR, ENGINE	1	1	SL FOR PWS1
17	128-27114-00	STOPPER, MAIN STAND	2	2	
18	34L-21485-00	DAMPER, RUBBER 1	1	1	
19	4N0-27114-00	STOPPER, MAIN STAND	1	1	
20	97007-06016	BOLT	1	1	
21	92907-06600	WASHER, PLATE	1	1	
22	4R8-21308-01	HELMET HANGER ASSY	1	1	
23	90151-06018	SCREW, COUNTERSUNK	1	1	
24	90480-12299	GROMMET	1	1	
25	2JX-21190-00-P1	REAR FRAME COMP.	1	1	S8 FOR PWS1
26	95827-06012	BOLT, FLANGE	4	4	
27	90338-12081	PLUG	2	2	

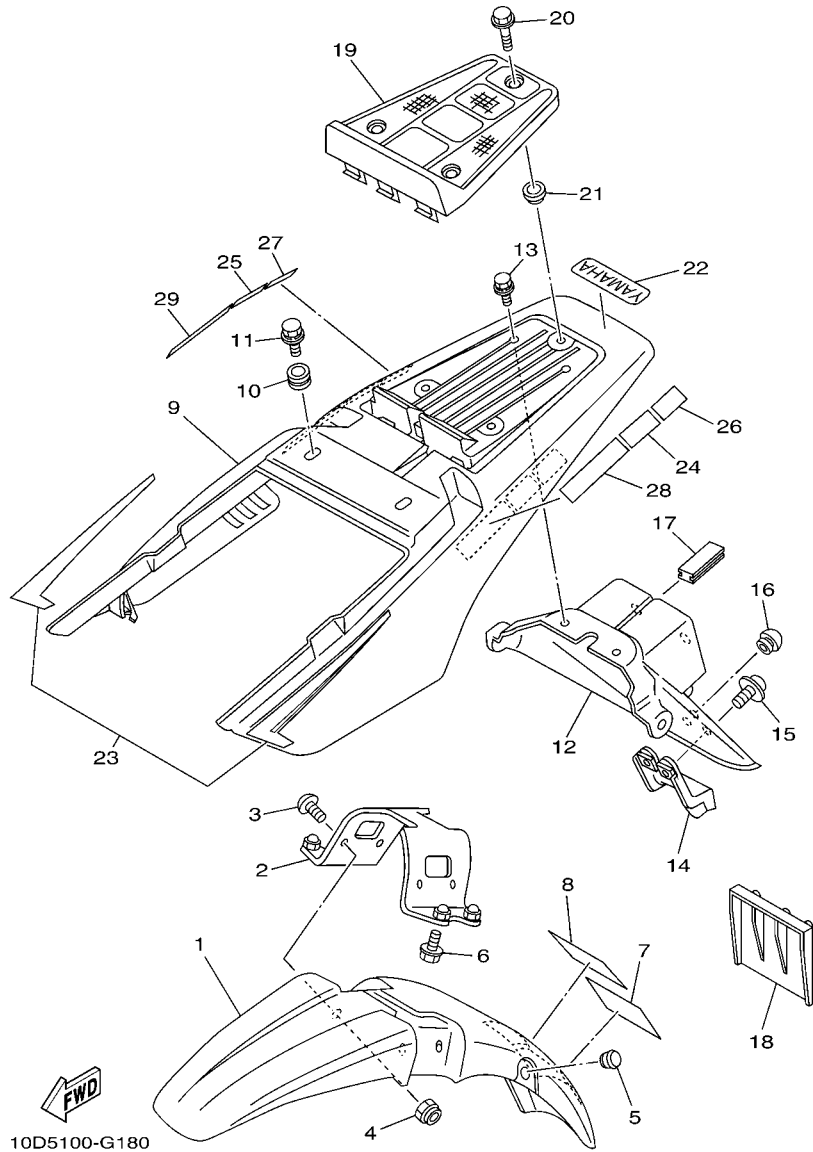

FIG. 18 FENDER

REF. NO.	PART NO.	DESCRIPTION	10DF	10DG	REMARKS
1	2YG-21511-00	FENDER, FRONT	1	1	YB
2	2JX-21512-00	BRACKET, FENDER	1	1	
3	90154-05004	SCREW, BINDING	4	4	
4	95607-05200	NUT, U FLANGE	4	4	
5	90338-12192	PLUG	1	1	
6	95807-06020	BOLT, FLANGE	4	4	
7	10D-21668-00	LABEL, TIRE	1	1	
8	10D-21668-10	LABEL, TIRE	1		
9	3AW-21611-20	FENDER, REAR	1	1	
10	90480-12053	GROMMET	2	2	
11	90119-06063	BOLT, WITH WASHER	4	4	
12	2JX-21685-00	BRACKET, LICENSE	1	1	
13	90119-06056	BOLT, WITH WASHER	2	2	
14	2JX-21641-00	BRACKET, REFLECTOR	1	1	
15	90159-05028	SCREW, WITH WASHER	2	2	
16	4G0-21639-00	DAMPER 2	1	1	
17	2JX-21669-00	SEAL	1	1	
18	5VC-21691-00	FLAP	1	1	
19	2JX-21651-10	COVER, REAR FENDER	1	1	
20	95024-06014	BOLT, FLG.(SMALL HEAD)	3	3	
21	90387-06681	COLLAR	3	3	
22	99244-00080	EMBLEM, YAMAHA	1	1	
23	10D-21660-20	GRAPHIC	1	1	

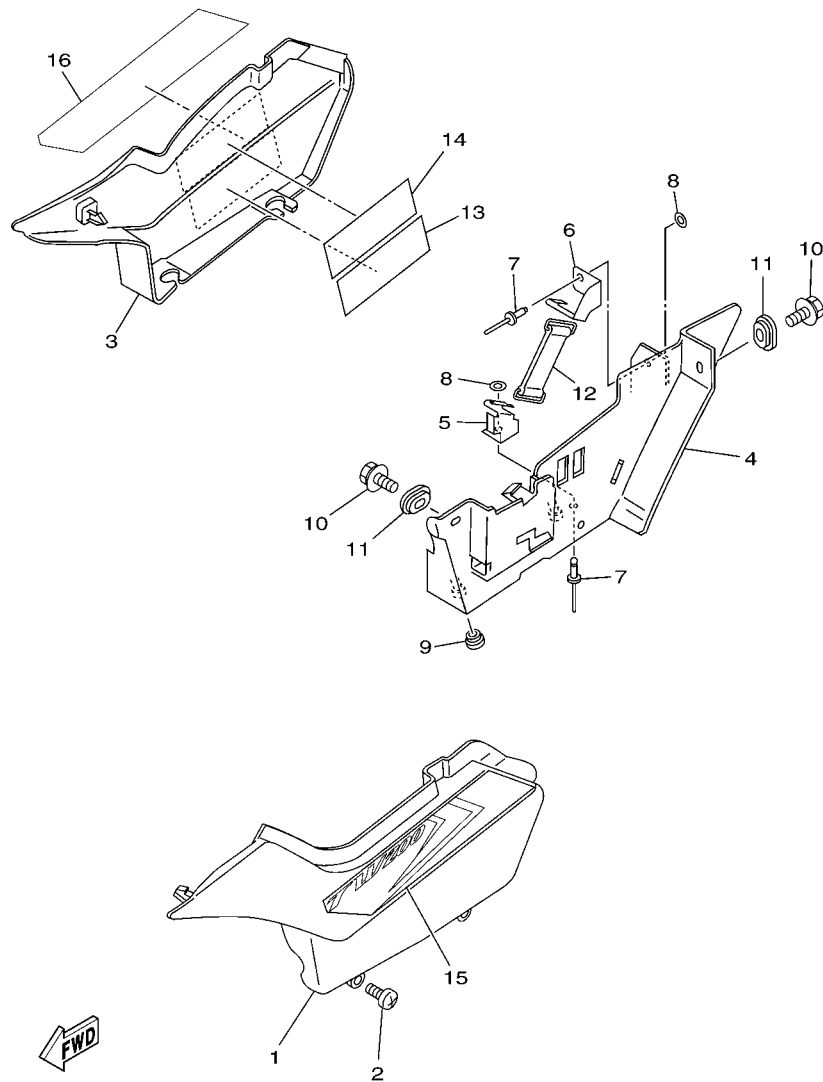
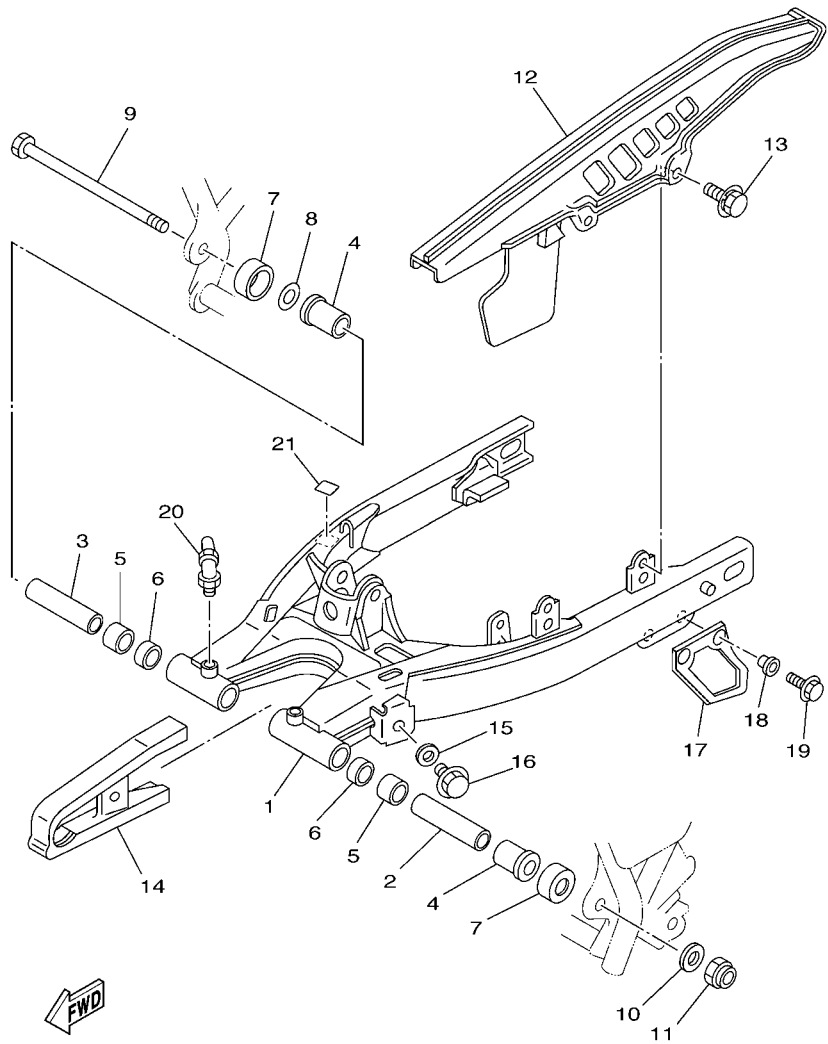

FIG. 19 SIDE COVER

REF. NO.	PART NO.	DESCRIPTION	10DF	10DG	REMARKS
1	3AW-21711-20-0X	COVER, SIDE 1	1	1	LGB FOR PWS1
2	90154-05013	SCREW, BINDING	2	2	
3	3AW-21721-20-0X	COVER, SIDE 2	1	1	LGB FOR PWS1
4	5EK-2177A-00	BOX	1	1	
5	5EK-2175T-00	BRACKET 1	1	1	
6	5EK-2175U-00	BRACKET 2	1	1	
7	90267-40075	RIVET, BLIND	2	2	
8	90201-04018	WASHER, PLATE	2	2	
9	90480-13197	GROMMET	2	2	
10	90119-06056	BOLT, WITH WASHER	2	2	
11	90480-01141	GROMMET	2	2	
12	116-82131-00	BAND, BATTERY	1	1	
15	10D-2173E-20	GRAPHIC, 1	1	1	
16	10D-2173F-20	GRAPHIC, 2	1	1	



5FYG100-B200

FIG. 20 REAR ARM

REF. NO.	PART NO.	DESCRIPTION	10DF	10DG		REMARKS
1	2JX-22110-00-35	REAR ARM COMP.	1	1		SL FOR PWS1
2	2JX-22123-00	BUSH 1	1	1		
3	2JX-22124-00	BUSH 2	1	1		
4	90386-18146	BUSH	2	2		
5	90380-18139	BUSH, SOLID	2	2		
6	93109-18020	OIL SEAL	2	2		
7	401-22128-01	COVER, THRUST 1	2	2		
8	401-22127-00	SHIM	1	1		
9	2JX-22141-00	SHAFT, PIVOT	1	1		
10	90201-120E8	WASHER, PLATE	1	1		
11	90185-12134	NUT, SELF-LOCKING	1	1		
12	34X-22311-00	CASE, CHAIN	1	1		
13	90119-05059	BOLT, WITH WASHER	2	2		
14	34X-22151-01	SEAL, GUARD	1	1		
15	90209-06187	WASHER	1	1		
16	90119-05062	BOLT, WITH WASHER	1	1		
17	5BT-22199-00	SUPPORT, CHAIN	1	1		
18	90387-06737	COLLAR	2	2		
19	95807-06020	BOLT, FLANGE	2	2		
20	93700-06009	NIPPLE, GREASE	2	2		
21	3MA-27491-00	PROTECTOR	1	1		

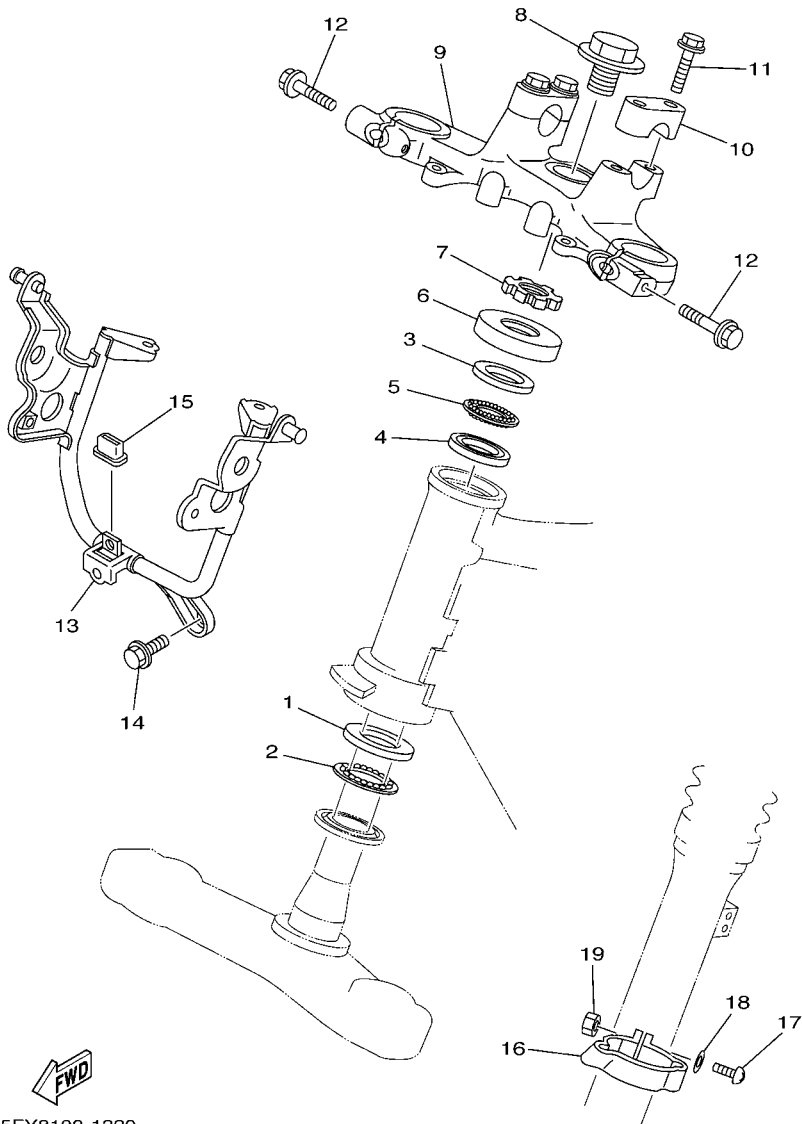

5FY8100-1220

FIG. 22 STEERING

REF. NO.	PART NO.	DESCRIPTION	100F	100G	REMARKS
1	156-23412-00	RACE, BALL 2	1	1	
2	156-2341E-00	RETAINER, BALL BEARING	1	1	
3	22F-23411-01	RACE, BALL 1	1	1	
4	22F-23412-01	RACE, BALL 2	1	1	
5	22F-2341E-00	RETAINER, BALL BEARING	1	1	
6	36X-23416-00	COVER, BALL RACE 2	1	1	
7	90179-25002	NUT	1	1	
8	90105-14102	BOLT, FLANGE	1	1	
9	2JX-23435-00-35	CROWN, HANDLE	1	1	SL FOR PWS1
10	1E6-23441-10-35	HOLDER, HANDLE UPPER	2	2	SL FOR PWS1
11	95824-08035	BOLT, FLANGE	4	4	
12	95024-08050	BOLT, FLG.(SMALL HEAD)	2	2	
13	5FY-23174-00	STAY, HEADLIGHT	1	1	
14	95807-06012	BOLT, FLANGE	1	1	
15	30X-23445-00	DAMPER	1	1	
16	34X-23317-00	HOLDER, CABLE	1	1	
17	98507-05018	SCREW, PAN HEAD	1	1	
18	92907-05600	WASHER, PLATE	1	1	
19	95307-05600	NUT	1	1	

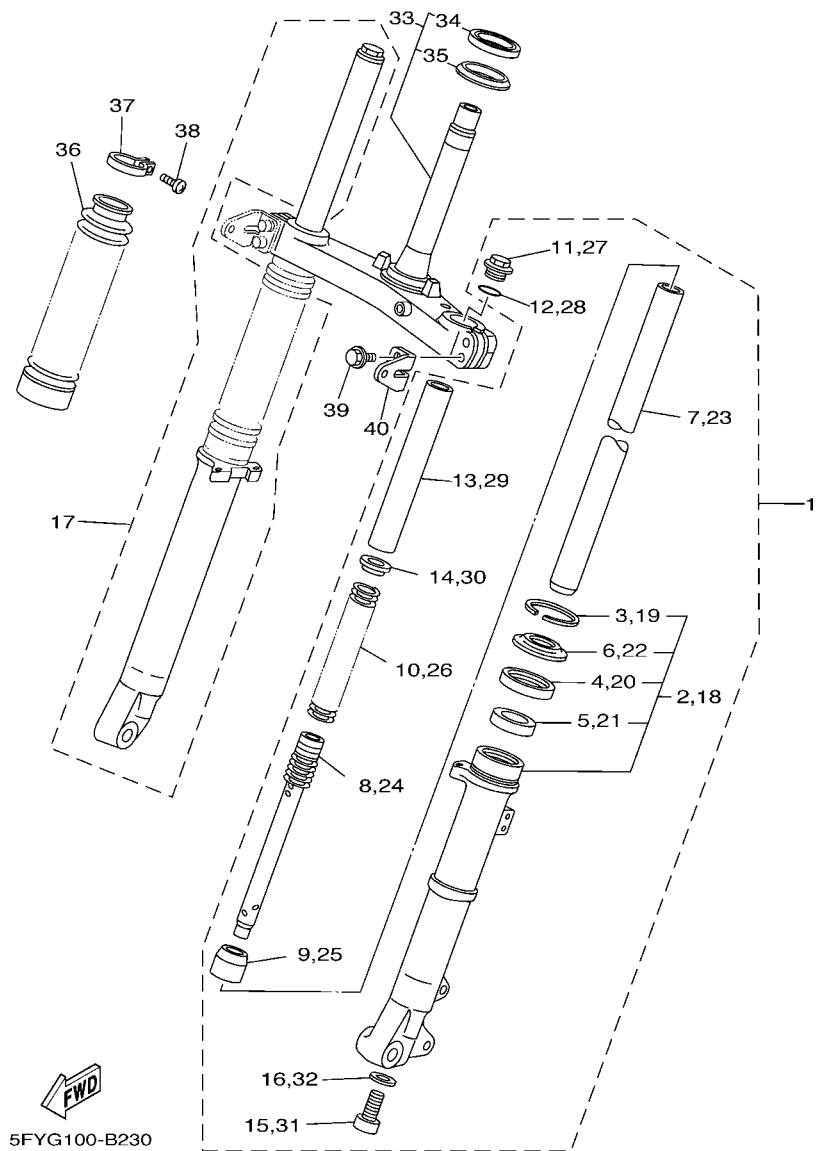

5FYG100-B230

FIG. 23 FRONT FORK

REF. NO.	PART NO.	DESCRIPTION	10DF	10DG	REMARKS
1	5FY-23102-20	FRONT FORK ASSY (L.H)	1	1	
2	5RS-23126-10	.TUBE, OUTER (LEFT)	1	1	
3	22W-23153-L0	..RING, SNAP	1	1	
4	22W-23145-L0	..OIL SEAL	1	1	
5	51Y-23125-00	..METAL, SLIDE 1	1	1	
6	54G-23144-00	..SEAL, DUST	1	1	
7	2JX-23110-00	.INNER TUBE COMP.1	1	1	
8	2JX-23170-00	.CYLINDER COMP., FRONT FORK	1	1	
9	3R6-23173-L0	.SPINDLE, TAPER	1	1	
10	2JX-23141-00	.SPRING, FRONT FORK	1	1	
11	2JN-23111-00	.BOLT, CAP	1	1	
12	3J2-23114-00	.O-RING	1	1	
13	22U-23118-01	.SPACER	1	1	
14	3DM-23149-10	.WASHER, SPRING UPPER	1	1	
15	278-23181-50	.BOLT, HEXAGON SOCKET HEAD	1	1	
16	509-23158-L0	.GASKET	1	1	
17	5FY-23103-20	FRONT FORK ASSY (R.H)	1	1	
18	5RS-23136-10	.TUBE, OUTER (RIGHT)	1	1	
19	22W-23153-L0	..RING, SNAP	1	1	
20	22W-23145-L0	..OIL SEAL	1	1	
21	51Y-23125-00	..METAL, SLIDE 1	1	1	
22	54G-23144-00	..SEAL, DUST	1	1	
23	2JX-23110-00	.INNER TUBE COMP.1	1	1	
24	2JX-23170-00	.CYLINDER COMP., FRONT FORK	1	1	
25	3R6-23173-L0	.SPINDLE, TAPER	1	1	
26	2JX-23141-00	.SPRING, FRONT FORK	1	1	
27	2JN-23111-00	.BOLT, CAP	1	1	

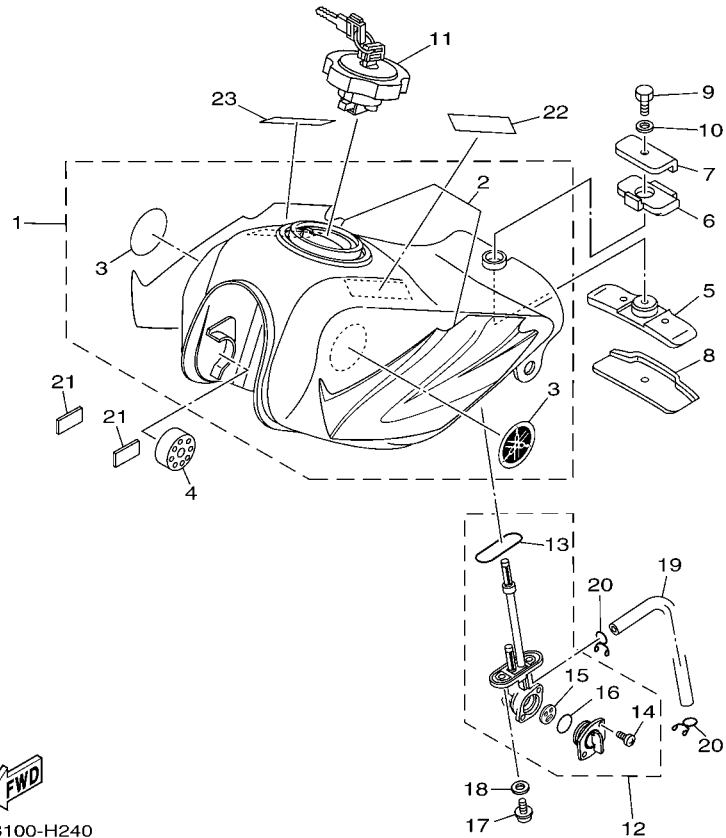
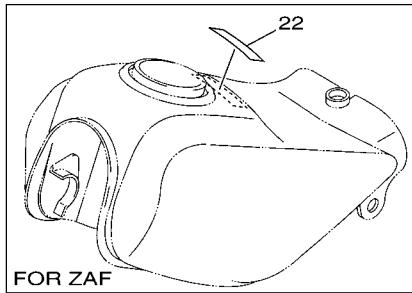

FWD
10DB100-H240

FIG. 24 FUEL TANK

REF. NO.	PART NO.	DESCRIPTION	10DF	10DG	REMARKS
1	5RS-Y2410-10-X8	FUEL TANK COMP.	1	1	FOR PWS1
2	10D-24240-20	.GRAPHIC SET	1	1	
3	5VX-2411B-00	.TUNING FORK MARK	2	2	
4	4L0-24181-00	DAMPER, LOCATING 1	2	2	
5	30X-24182-01	DAMPER, LOCATING 2	1	1	
6	30X-24183-01	DAMPER, LOCATING 3	1	1	
7	30X-24186-01	WASHER, SPECIAL	1	1	
8	30X-24187-00	WASHER, SPECIAL	1	1	
9	97007-06012	BOLT	1	1	
10	92907-06600	WASHER, PLATE	1	1	
11	11H-24602-03	CAP ASSY	1	1	
12	23F-24500-11	FUEL COCK ASSY 1	1	1	
13	4X8-24512-00	.O-RING	1	1	
14	98507-03008	.SCREW, PAN HEAD	2	2	
15	3AC-24523-00	.VALVE PACKING	1	1	
16	3AJ-24534-01	.SEAL, COCK	1	1	
17	90149-06011	SCREW	2	2	
18	90202-05193	WASHER, PLATE	2	2	
19	90445-10007	HOSE		1	
20	90467-09006	CLIP	2	2	
21	2JX-24141-00	PROTECTOR, FUEL TANK	2	2	
22	5PA-21568-01	LABEL, CAUTION		1	

FIG. 26 FRONT WHEEL

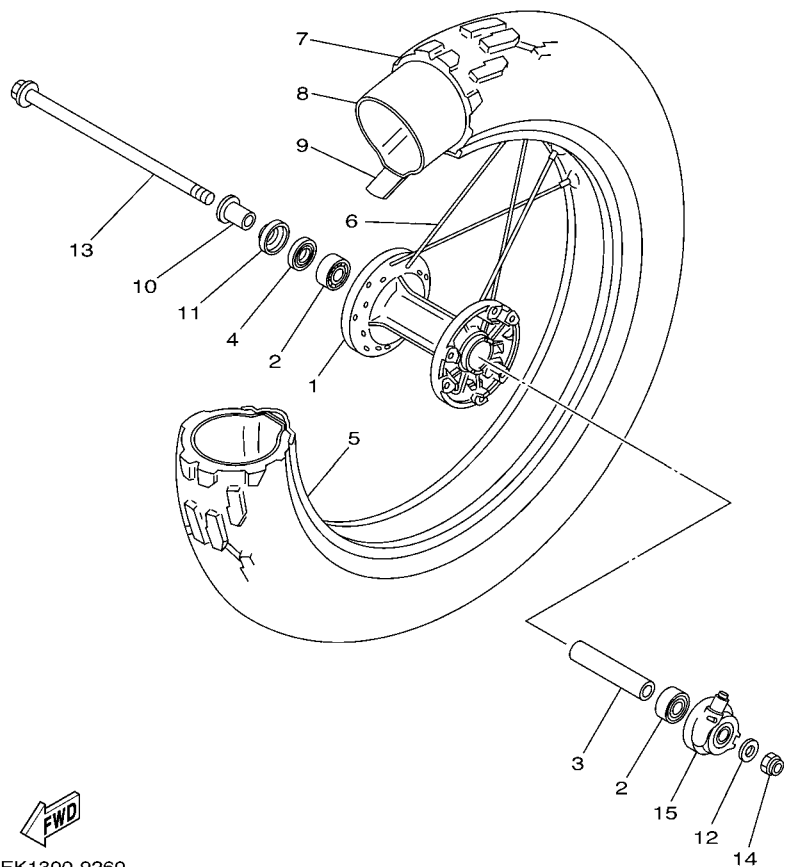

FWD
5EK1300-9260

REF. NO.	PART NO.	DESCRIPTION	10DF	10DG	REMARKS
1	5EK-25111-00	HUB, FRONT	1	1	
2	93306-20203	BEARING	2	2	
3	90560-15312	SPACER	1	1	
4	93102-20281	OIL SEAL (SD 20-35-5)	1	1	
5	94425-18002	RIM (2.50-18)	1	1	
6	4TP-25304-10	SPOKE SET	1	1	
7	L.M.	TIRE (130/80-18 M/C 66P TW31)	1	1	
8	L.M.	TUBE (130/80-18 M/C TR4)	1	1	
9	94340-18086	BAND, RIM (2.50-18)	1	1	BRIDGESTONE
10	90387-15600	COLLAR	1	1	
11	322-25118-00	COVER, HUB DUST	1	1	
12	90201-14740	WASHER, PLATE	1	1	
13	2JX-25181-10	AXLE, WHEEL	1	1	
14	95607-14100	NUT, U	1	1	
15	5EK-25190-00	GEAR UNIT ASSY	1	1	

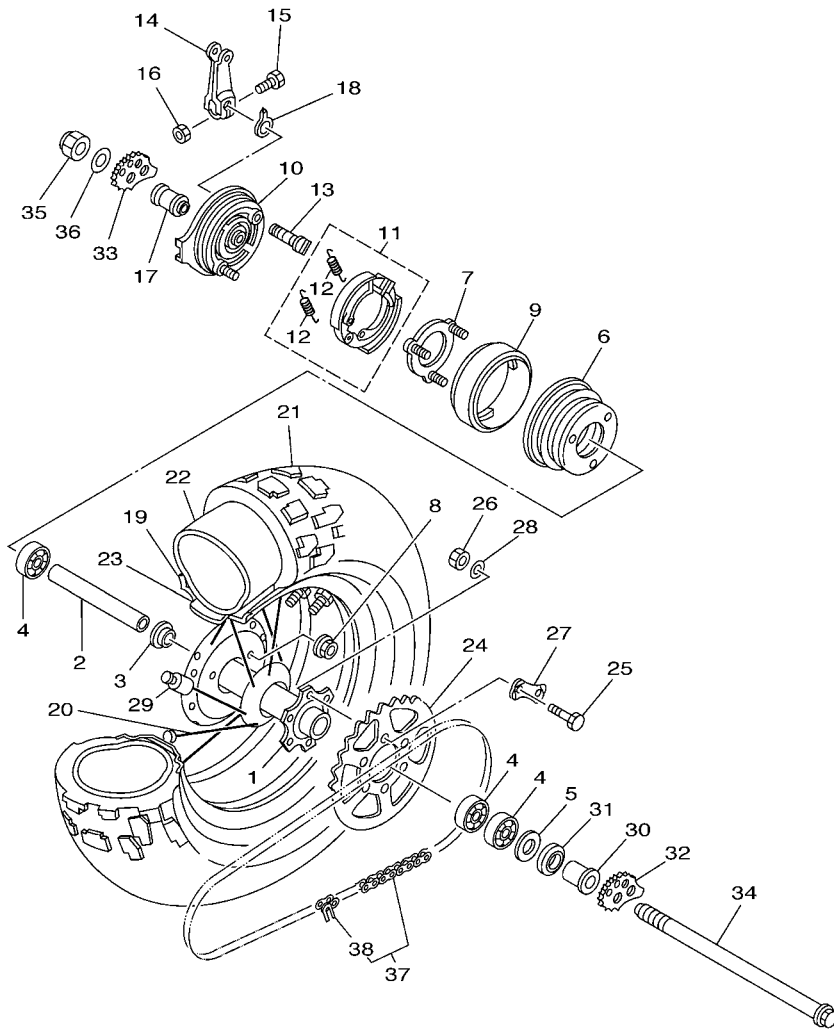

5FY8100-1280

FIG. 28 REAR WHEEL

REF. NO.	PART NO.	DESCRIPTION	10DF	10DG	REMARKS
1	2JX-25311-00	HUB, REAR	1	1	
2	90560-17305	SPACER	1	1	
3	152-25115-00	FLANGE, SPACER 1	1	1	
4	93306-20348	BEARING	3	3	
5	93102-25311	OIL SEAL (FPJ 25-44-8 TS)	1	1	
6	5V7-2511E-00-35	DRUM, BRAKE	1	1	SL FOR PWS1
7	54G-25185-00	RING 1	1	1	
8	90179-08410	NUT	3	3	
9	2JX-25336-00	RING 2	1	1	
10	2JX-25321-02-35	PLATE, BRAKE SHOE	1	1	SL FOR PWS1
11	4KN-W253E-11	BRAKE SHOE KIT	1	1	
12	90506-15260	.SPRING, TENSION	2	2	
13	3Y6-25351-00	CAMSHAFT	1	1	
14	2N3-25155-00	LEVER, CAMSHAFT 1	1	1	
15	90101-06278	BOLT	1	1	
16	95307-06600	NUT	1	1	
17	90387-171T1	COLLAR	1	1	
18	2JX-2533A-00	PLATE, INDICATOR	1	1	
19	94445-14605	RIM (MT4.50-14 M/C)	1	1	
20	2JX-25304-21	SPOKE SET, REAR	1	1	
21	L.M.	TIRE (180/80-14 M/C 78P TW34)	1	1	
22	L.M.	TUBE (180/80-14 M/C TR4)	1	1	
23	94318-14149	BAND, RIM (4.50-14)	1	1	BRIDGESTONE
24	15A-25450-20	SPROCKET, DRIVEN (50T)	1	1	
25	90109-08618	BOLT	6	6	
26	90185-08089	NUT, SELF-LOCKING	6	6	
27	90215-08160	WASHER, LOCK	3	3	

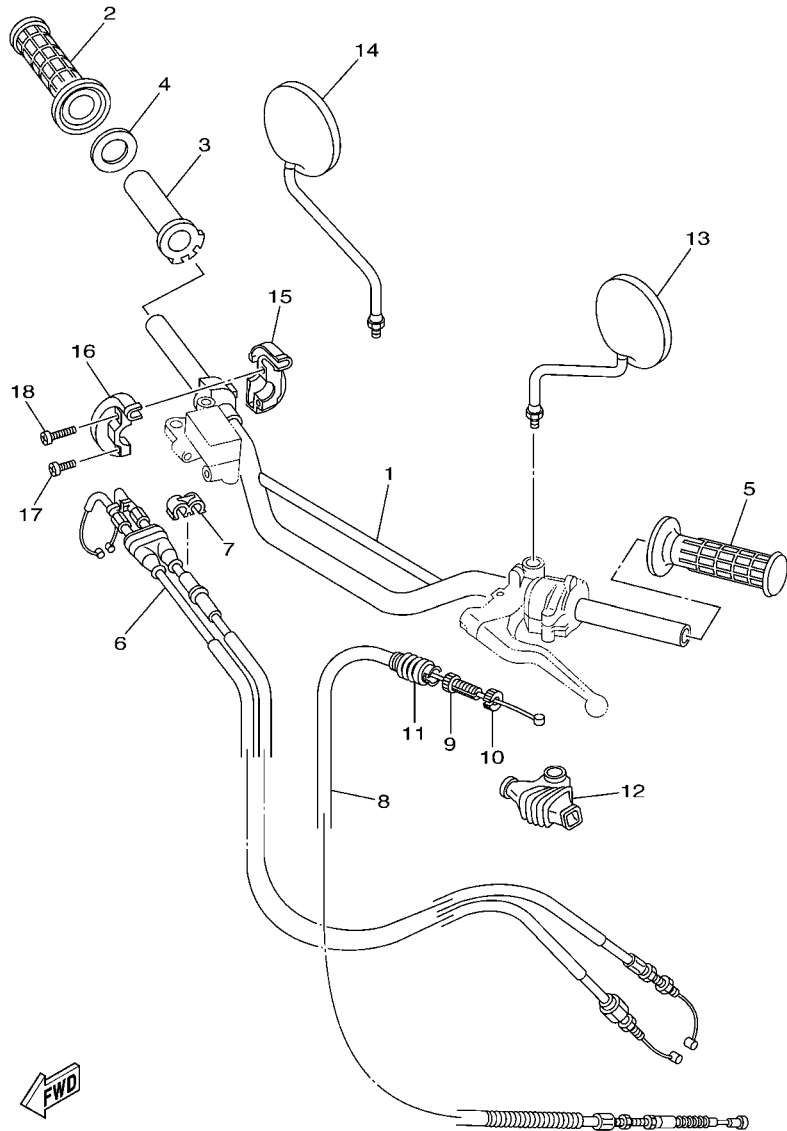

FWD
5FYG100-B290

FIG. 29 STEERING HANDLE & CABLE

REF. NO.	PART NO.	DESCRIPTION	100F	100G	REMARKS
1	5LB-26111-00	HANDLE BAR	1	1	
2	1LX-26242-01	GRIP (RIGHT)	1	1	
3	5BE-26243-00	TUBE, THROTTLE GUIDE	1	1	
4	3Y1-26249-00	RING, LEAF	1	1	
5	1LX-26241-01	GRIP (LEFT)	1	1	
6	5LB-26302-02	THROTTLE CABLE ASSY	1	1	
7	90464-06214	CLAMP	1	1	
8	5EK-26335-00	CABLE, CLUTCH	1	1	
9	90123-08046	BOLT	1	1	
10	90179-08148	NUT	1	1	
11	1E6-26342-00	BOOT, CABLE	1	1	
12	1E6-26372-00	COVER, HANDLE LEVER 1	1	1	
13	3Y1-26290-10	BACK MIRROR ASSY (L.H)	1	1	
14	3Y1-26290-00	BACK MIRROR ASSY (R.H)	1	1	
15	3LN-26281-01	CAP, GRIP UPPER	1	1	
16	3LN-26282-01	CAP, GRIP UNDER	1	1	
17	98507-05020	SCREW, PAN HEAD	1	1	
18	98507-05025	SCREW, PAN HEAD	1	1	

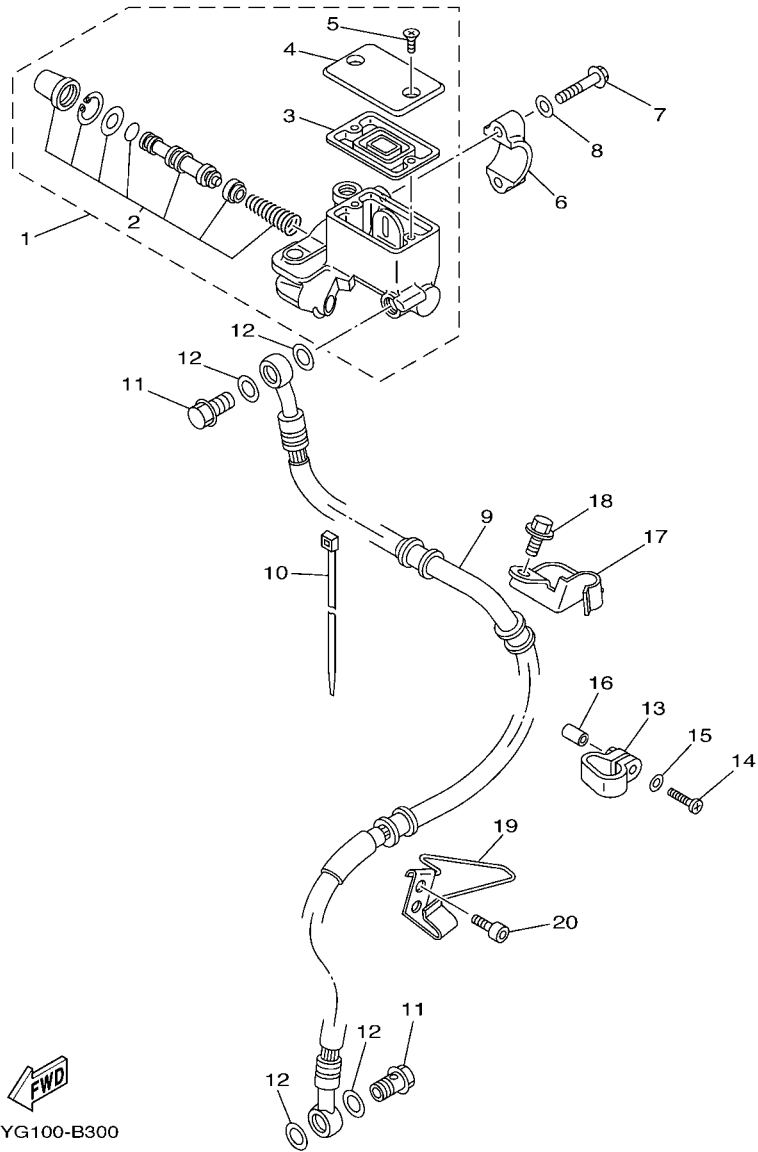
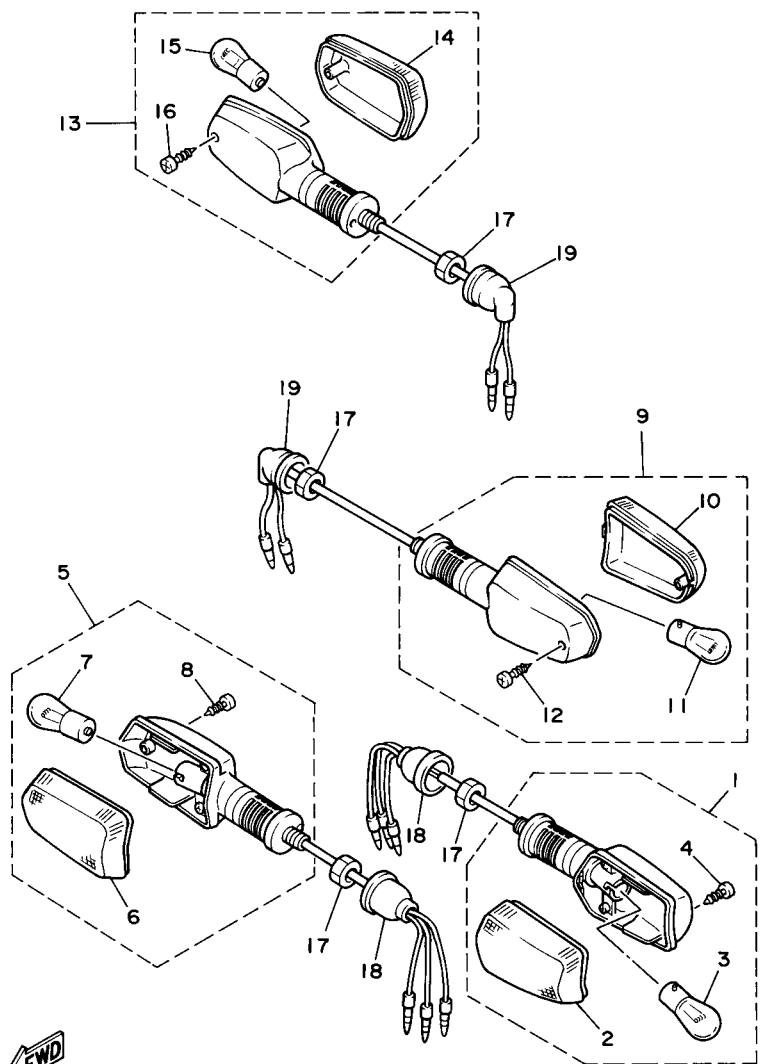

FIG. 30 FRONT MASTER CYLINDER

REF. NO.	PART NO.	DESCRIPTION	10DF	10DG	REMARKS
1	5RS-25870-01	MASTER CYLINDER SUB ASSY	1	1	
2	5CG-W0041-00	.CYLINDER KIT, MASTER	1	1	
3	5RB-25854-00	.GASKET, DIAPHRAGM	1	1	
4	4GY-25852-01	.CAP, RESERVOIR	1	1	
5	36Y-2589H-00	.SCREW	2	2	
6	3RW-25867-00	BRACKET, MASTER CYLINDER	1	1	
7	97007-06025	BOLT	2	2	
8	92907-06600	WASHER, PLATE	2	2	
9	5RS-25872-00	HOSE, BRAKE 1	1	1	
10	1UA-82591-00	BAND	1	1	
11	90401-10159	BOLT, UNION	2	2	
12	90201-10118	WASHER, PLATE	4	4	
13	3TB-23467-01	CLAMP	1	1	
14	98507-04018	SCREW, PAN HEAD	1	1	
15	92907-04600	WASHER	1	1	
16	90445-057G5	HOSE (L10)	1	1	
17	5RS-25886-00	HOLDER, BRAKE HOSE	1	1	
18	95807-06012	BOLT, FLANGE	1	1	
19	34X-25876-00	HOLDER, BRAKE HOSE 2	1	1	
20	91317-06010	BOLT	2	2	



2YGI10-8330

FIG. 35 FLASHER LIGHT

REF. NO.	PART NO.	DESCRIPTION	10DF	10DG	REMARKS
1	1UF-83310-00	FRONT FLASHER LIGHT ASSY 1	1	1	
2	51L-83332-01	.LENS, FLASHER	1	1	
3	256-84714-61	.BULB (12V-27/8W)	1	1	
4	97707-40620	.SCREW, TAPPING	1	1	
5	1UF-83320-00	FRONT FLASHER LIGHT ASSY 2	1	1	
6	51L-83342-01	.LENS, FLASHER 2	1	1	
7	256-84714-61	.BULB (12V-27/8W)	1	1	
8	97707-40620	.SCREW, TAPPING	1	1	
9	1UF-83330-00	REAR FLASHER LIGHT ASSY 1	1	1	
10	51L-83342-00	.LENS, FLASHER 2	1	1	
11	256-83311-70	.BULB (12V-27W)	1	1	
12	97706-40620	.SCREW, TAPPING	1	1	
13	1UF-83340-00	REAR FLASHER LIGHT ASSY 2	1	1	
14	51L-83332-00	.LENS, FLASHER	1	1	
15	256-83311-70	.BULB (12V-27W)	1	1	
16	97706-40620	.SCREW, TAPPING	1	1	
17	95307-12700	NUT	4	4	
18	10V-83365-00	CAP	2	2	
19	18G-83365-00	CAP	2	2	

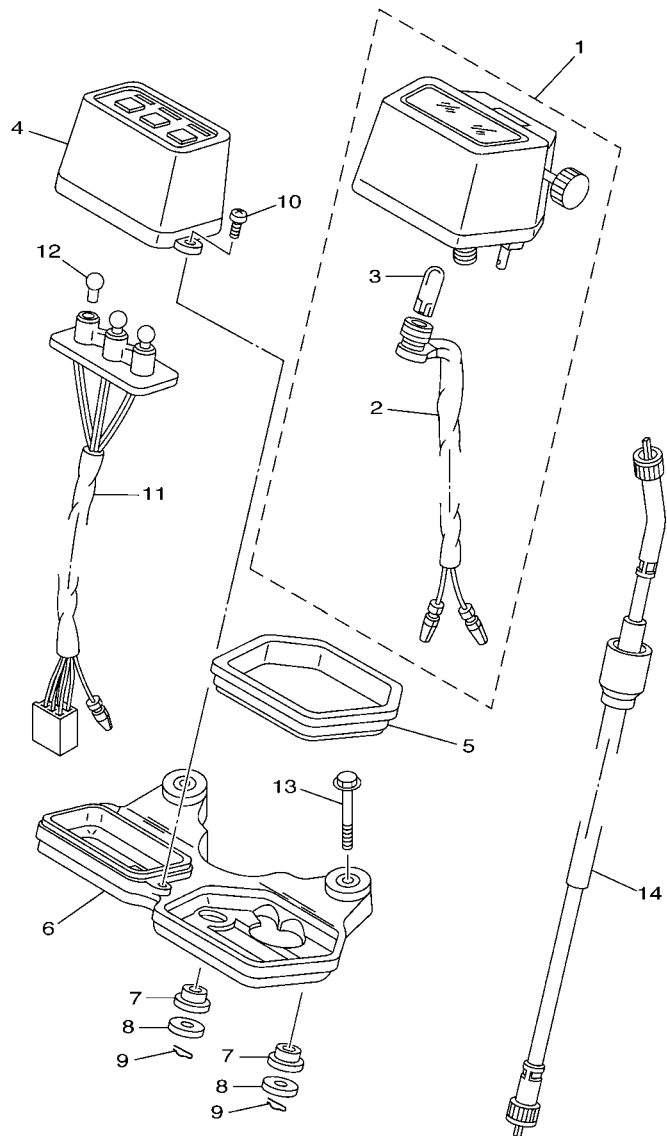

5FY8100-1360

FIG. 36 METER

REF. NO.	PART NO.	DESCRIPTION	10DF	10DG	REMARKS
1	4CS-83510-00	SPEEDOMETER ASSY	1	1	
2	2JX-83536-A0	.SOCKET, METER	1	1	
3	4R0-83517-00	.BULB (12V-3.4W T10)	1	1	
4	5EK-83568-00	PILOT BOX, UPPER	1	1	
5	5Y1-83513-00	DAMPER	1	1	
6	15A-83519-00	BRACKET, METER	1	1	
7	1M1-83526-00	DAMPER 2	2	2	
8	90201-05033	WASHER, PLATE	2	2	
9	437-83525-00	CLIP	2	2	
10	90164-04008	SCREW, TAPPING	2	2	
11	15A-83509-00	SOCKET CORD ASSY	1	1	
12	123-83516-21	BULB (12V-3.4W)	3	3	
13	95807-06040	BOLT, FLANGE	2	2	
14	5LB-83550-00	SPEEDOMETER CABLE ASSY	1	1	

FIG. 37 HEADLIGHT

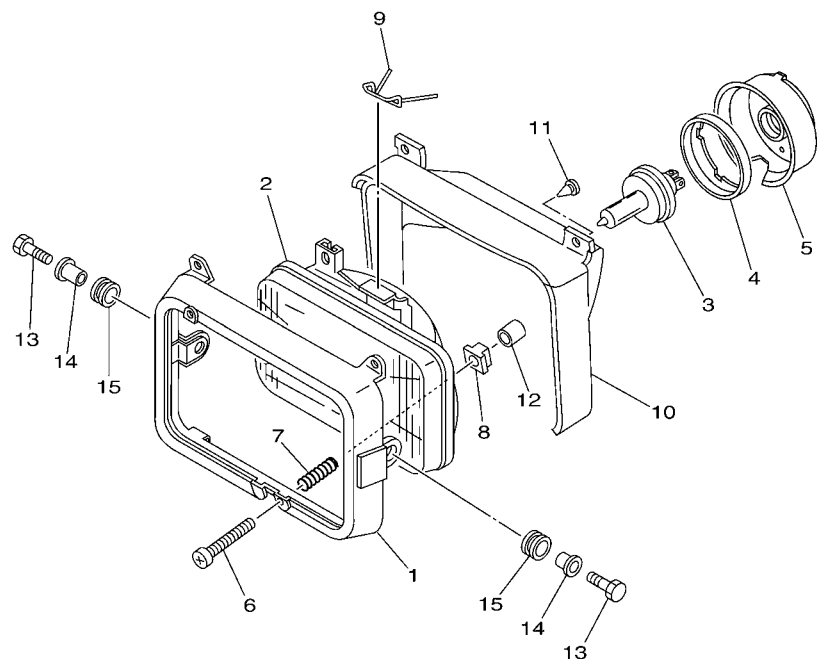

5FY8100-1371

REF. NO.	PART NO.	DESCRIPTION	10DF	10DG		REMARKS
1	47J-84115-00	RIM, HEADLIGHT	1	1		
2	5FY-84320-00	LENS ASSY	1	1		
3	2F9-84314-00	BULB (12V-60/55W)	1	1		LM (H4)HALOGEN
4	2F9-84375-00	SETTING PLATE, BULB	1	1		
5	2F9-84397-01	COVER, SOCKET	1	1		
6	43F-84131-00	SCREW, RIM ADJUSTER	2	2		
7	5G2-84332-60	SPRING, SCREW	2	2		
8	198-84334-60	NUT, ADJUSTING	2	2		
9	5G2-84324-A0	SPRING, REFLECTOR	1	1		
10	30X-84196-00	COVER, SOCKET	1	1		
11	10V-84198-00	CLIP, COVER FITTING	2	2		
12	2RR-84178-00	PLUG	1	1		
13	97007-06025	BOLT	2	2		
14	90387-063E6	COLLAR	2	2		
15	90480-14023	GROMMET	2	2		

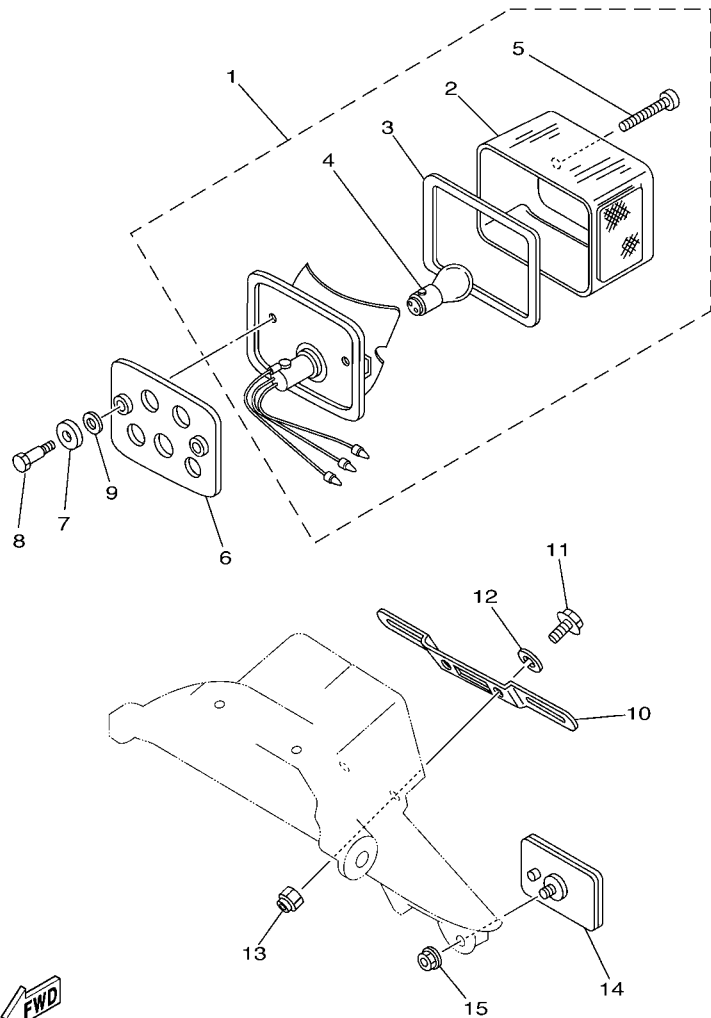

5FYG100-B390

FIG. 38 TAILLIGHT

REF. NO.	PART NO.	DESCRIPTION	10DF	10DG	REMARKS
1	1W9-84710-61	TAILLIGHT UNIT ASSY	1	1	
2	1M1-84521-60	.LENS, TAILLIGHT	1	1	
3	1M1-84523-60	.GASKET, LENS	1	1	
4	256-84714-61	.BULB (12V-27/8W)	1	1	
5	1M1-84524-60	.SCREW, LENS FITTING	2	2	
6	4L0-84753-00	DAMPER	1	1	
7	90209-08125	WASHER	2	2	
8	90109-06005	BOLT	2	2	
9	90201-083A0	WASHER, PLATE	2	2	
10	36A-84551-00	BRACKET, LICENCE	1	1	
11	95807-06016	BOLT, FLANGE	2	2	
12	90201-06557	WASHER, PLATE	2	2	
13	95607-06100	NUT, U	2	2	
14	3G1-85130-01	REAR REFLECTOR ASSY	1	1	
15	95707-05500	NUT, FLANGE	1	1	

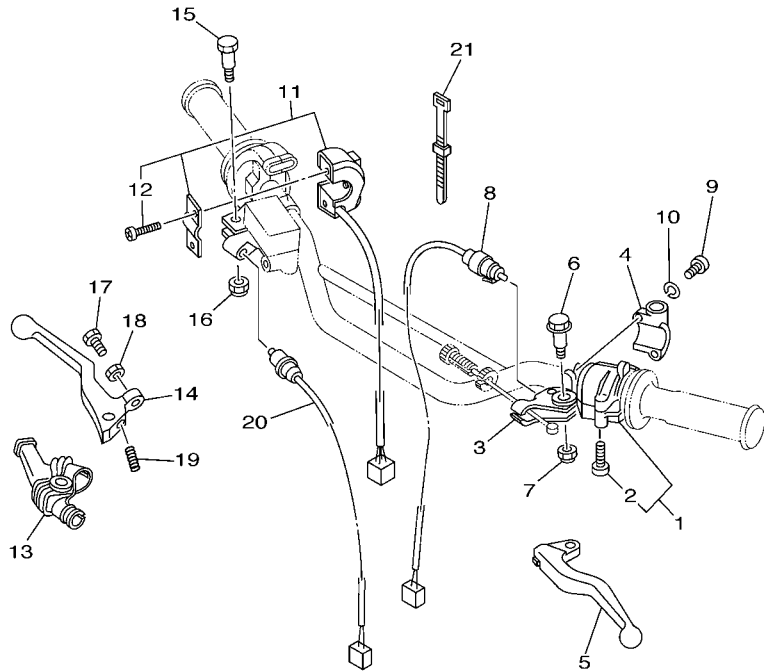

FIG. 39 HANDLE SWITCH & LEVER

REF. NO.	PART NO.	DESCRIPTION	10DF	10DG		REMARKS
1	4CS-83973-00	SWITCH, HANDLE 3	1	1		
2	98507-05030	.SCREW, PAN HEAD	2	2		
3	1LN-82911-00	HOLDER, LEVER 1	1	1		
4	33G-82913-01	HOLDER, LEVER LOWER 1	1	1		
5	4GY-83912-00	LEVER 1	1	1		
6	90109-06799	BOLT	1	1		
7	95607-06100	NUT, U	1	1		
8	4GY-82917-01	SWITCH	1	1		
9	98507-05020	SCREW, PAN HEAD	2	2		
10	92907-05100	WASHER, SPRING	2	2		
11	5LB-83975-01	SWITCH, HANDLE 2	1	1		
12	98507-05018	.SCREW, PAN HEAD	2	2		
13	1T5-26372-00	COVER, HANDLE LEVER 1	1	1		
14	55Y-83922-00	LEVER 2	1	1		
15	90109-06577	BOLT	1	1		
16	95607-06100	NUT, U	1	1		
17	90149-06131	SCREW	1	1		
18	90170-06010	NUT	1	1		
19	90501-10312	SPRING, COMPRESSION	1	1		
20	3DM-83980-00	FRONT STOP SWITCH ASSY	1	1		
21	437-83936-01	BAND, SWITCH CORD	4	4		



5LB1010-0500

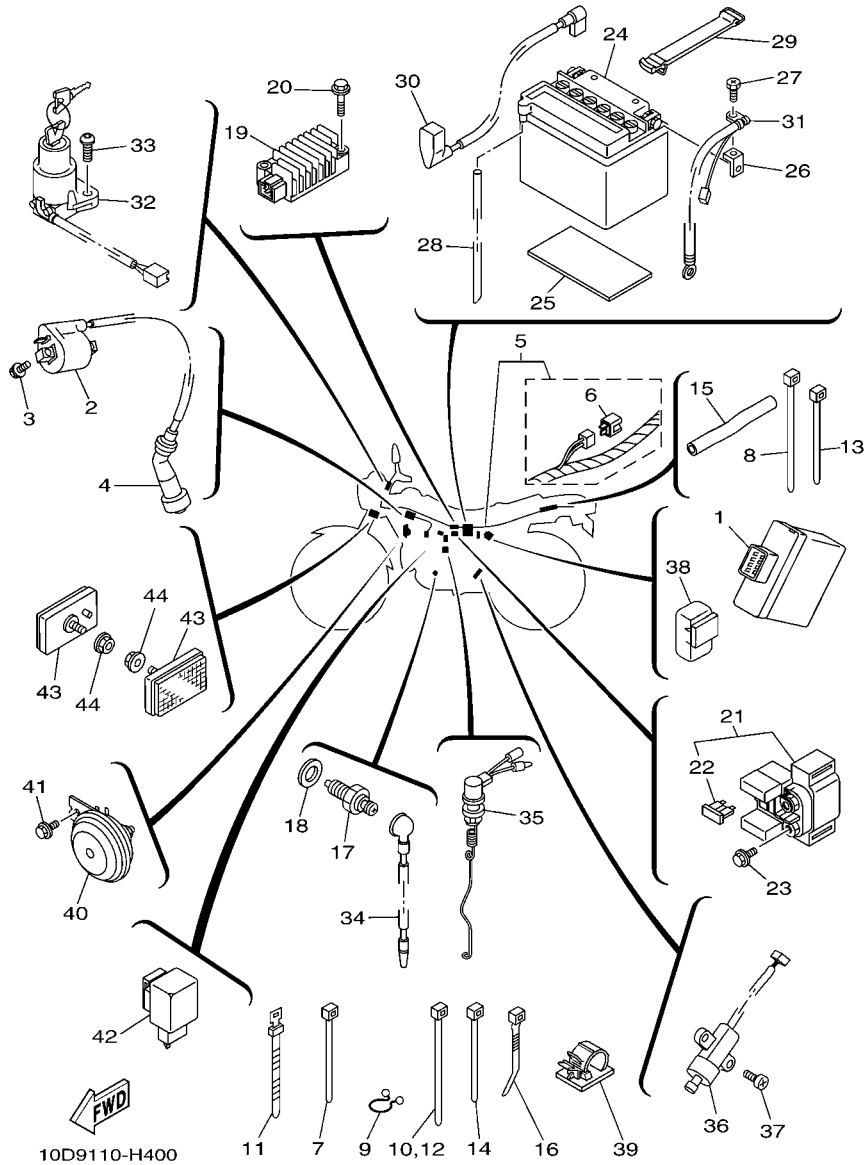
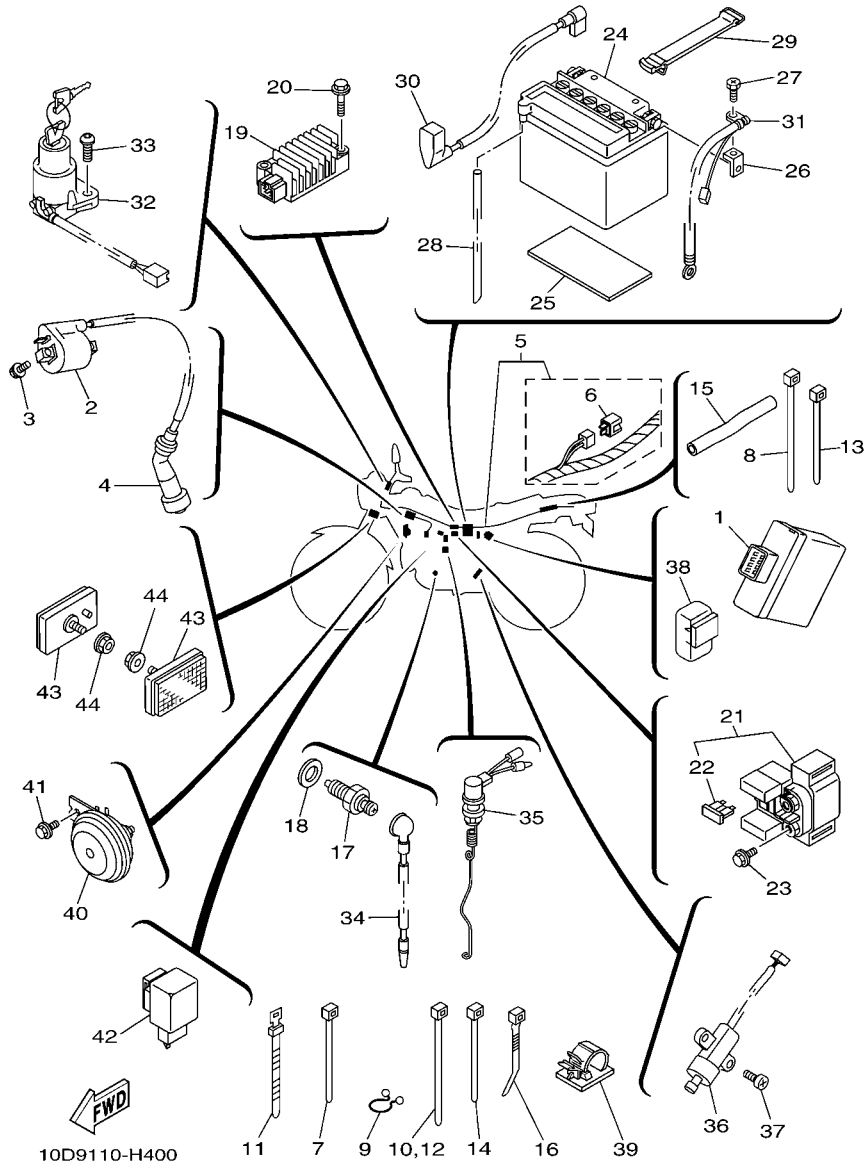

FIG. 40 ELECTRICAL 1

REF. NO.	PART NO.	DESCRIPTION	10DF	10DG	REMARKS
1	5LB-85540-01	C.D.I. UNIT ASSY	1	1	
2	3RW-82310-10	IGNITION COIL ASSY	1	1	
3	95027-06016	BOLT, FLANGE	2	2	
4	1UY-82370-20	PLUG CAP ASSY	1	1	
5	5FY-82590-20	WIRE HARNESS ASSY	1	1	
6	3WP-81980-00	.DIODE ASSY	1	1	
7	5Y9-12491-00	CLAMP 1	1	1	
8	1UA-82591-00	BAND	1	1	
9	341-82594-00	CLAMP	1	1	
10	1UA-82591-00	BAND	1	1	
11	25G-83936-01	BAND, SWITCH CORD	2	2	
12	1UA-82591-00	BAND	2	2	
13	5Y9-12491-00	CLAMP 1	1	1	
14	5Y9-12491-00	CLAMP 1	2	2	
15	90446-15377	HOSE	2	2	
16	90465-10098	CLAMP	3	3	
17	4GY-82540-10	NEUTRAL SWITCH ASSY	1	1	
18	90430-10148	GASKET	1	1	
19	3TJ-81960-02	RECTIFIER & REGULATOR ASSY	1	1	
20	95027-06025	BOLT, FLANGE	2	2	
21	5EK-81940-02	STARTER RELAY ASSY	1	1	
22	2GH-82151-00	.FUSE (20A-BL)	2	2	
23	95027-06008	BOLT, FLANGE	2	2	
24	1JE-82110-61	BATTERY ASSY (GS GM7CZ-3D)	1	1	
25	51Y-82122-00	SEAT, BATTERY	1	1	
26	5LB-8215C-00	TERMINAL	2	2	
27	90153-06001	SCREW, HEXAGON	2	2	



10D9110-H400

FIG. 40 ELECTRICAL 1

REF. NO.	PART NO.	DESCRIPTION	10DF	10DG	REMARKS
28	90445-082F3	HOSE (L540)	1	1	
29	18G-82131-00	BAND, BATTERY	1	1	
30	5LB-82115-00	WIRE, PLUS LEAD	1	1	
31	5EK-82116-02	WIRE, MINUS LEAD	1	1	
32	5LB-82501-01	MAIN SWITCH STEERING LOCK	1	1	
33	90149-06228	SCREW	2	2	
34	5VC-82541-10	WIRE, LEAD	1	1	
35	5VC-82530-00	STOP SWITCH ASSY	1	1	
36	3LD-82566-60	SWITCH, SIDE STAND	1	1	
37	90157-05008	SCREW, PAN HEAD	2	2	
38	29U-81950-93	RELAY ASSY	1	1	
39	90464-13004	CLAMP	1	1	
40	5LB-83371-11	HORN	1	1	
41	95807-06012	BOLT, FLANGE	1	1	
42	4MY-83350-01	FLASHER RELAY ASSY	1	1	
43	20G-85110-00	REFLECTOR ASSY	2	2	
44	95707-05500	NUT, FLANGE	2	2	

NUMERICAL INDEX

PART NO.	REF. NO.	PART NO.	REF. NO.	PART NO.	REF. NO.	PART NO.	REF. NO.	PART NO.	REF. NO.	PART NO.	REF. NO.
15A-11110-04	1 - 1	5Y9-12491-00	40 - 7	2JX-14451-00	7 - 11	1W1-16358-01	13 - 13	2JX-21669-00	18 - 17	22W-23153-L0	23 - 19
5H0-1111F-00	1 - 19		40 - 13	2JX-14452-00	7 - 9	2JX-16371-00	13 - 7	2JX-21685-00	18 - 12	509-23158-L0	23 - 16
5H0-11133-11	1 - 5		40 - 14	5LB-14453-10	7 - 6	15A-16380-00	13 - 20	5VC-21691-00	18 - 18		23 - 32
15A-11161-01	1 - 25	5H0-13300-02	6 - 1	5U8-14457-00	7 - 14	15A-17121-00	14 - 7	3AW-21711-20-0X	19 - 1	2JX-23170-00	23 - 8
15A-11162-00	1 - 23	5H0-13326-01	6 - 2	2JX-14458-00	7 - 12	5H0-17121-01	14 - 5	3AW-21721-20-0X	19 - 3		23 - 24
5H0-11162-00	1 - 24	4BE-13329-01	6 - 4	5LB-14589-00	8 - 18	15A-17141-00	14 - 6	10D-2173E-20	19 - 15	3R6-23173-L0	23 - 9
3Y1-11166-00	10 - 11	5Y1-13411-00	6 - 6	5LB-14592-00	8 - 28	15A-17151-01	14 - 2	10D-2173F-20	19 - 16		23 - 25
371-11167-01	10 - 3	5H0-13440-09	6 - 10	2JX-14611-02	9 - 1	15A-17211-01	14 - 18	5EK-2175T-00	19 - 5	5FY-23174-00	22 - 13
1NU-11181-00	1 - 6	15A-13447-00	6 - 11	5H0-14612-01	9 - 2	15A-17221-00	14 - 12	5EK-2175U-00	19 - 6	278-23181-50	23 - 15
15A-11185-00	1 - 12	5LB-13584-00	7 - 22	4BE-14613-00	9 - 19	15A-17231-00	14 - 14	5EK-2177A-00	19 - 4		23 - 31
15A-11186-00	1 - 15	5LB-13586-02	7 - 1	5LB-14628-00	9 - 3	15A-17241-00	14 - 13	2JX-22110-00-35	20 - 1	4CS-23191-20	23 - 36
15A-11187-00	1 - 16	5LB-14105-00	8 - 16	2JX-14711-10	9 - 6	1EV-17251-00	14 - 15	2JX-22123-00	20 - 2	2K5-23192-00	23 - 37
47J-11310-00	2 - 1	5FY-14196-00	8 - 31	2JL-14711-21	9 - 6	2JX-17402-00	14 - 11	2JX-22124-00	20 - 3	1W4-23194-L0	23 - 38
5VC-11351-10	2 - 3	5LB-14196-00	8 - 31	3YF-14714-00	9 - 11	15A-17411-01	14 - 1	401-22127-00	20 - 8	34X-23317-00	22 - 16
5H0-11400-01	3 - 1	5FY-14197-00	8 - 30	2JX-14728-00	9 - 7	2JX-17456-00	14 - 26	401-22128-01	20 - 7	5LB-23340-01	23 - 33
5H0-11412-09	3 - 2	5LB-14197-00	8 - 30	1RH-14752-01	9 - 15	2JX-17471-00	14 - 28	30X-22129-00	21 - 12	5RS-23346-00	23 - 39
5H0-11422-00	3 - 3	5LB-14216-00	8 - 11	5LB-14936-00	8 - 7	1RL-18110-00	16 - 8	2JX-22141-00	20 - 9	156-23411-00	23 - 34
15A-11454-00	3 - 22	5LB-14275-00	8 - 8	1RL-15100-03	10 - 1	132-18113-01	16 - 9	34X-22151-01	20 - 14	22F-23411-01	22 - 3
5H0-11496-00	3 - 13	5LB-14286-00	8 - 10	55X-15167-00	11 - 25	5H0-18120-02	16 - 1	5BT-22199-00	20 - 17	156-23412-00	22 - 1
5H0-11531-00	3 - 21	5LB-14292-00	8 - 29	5H0-15351-00	6 - 8	1RH-18140-00	15 - 8	5FY-22210-10-P0	21 - 1	22F-23412-01	22 - 4
5H0-11536-00	3 - 16	5LB-14293-00	8 - 19	3Y1-15361-00	11 - 23	1RH-18185-00	15 - 4	5FY-22210-20-P0	21 - 1	36X-23416-00	22 - 6
15A-11603-00	3 - 9	5LB-14301-01	8 - 1	3Y1-15363-10	11 - 21	4JG-18511-00	15 - 10	1M1-22216-00	21 - 3	156-2341E-00	22 - 2
15A-11605-00	3 - 9	5FY-14301-10	8 - 1	2JX-15377-00	11 - 2	4JG-18512-01	15 - 11	4AA-22259-40	21 - 4	22F-2341E-00	22 - 5
15A-11607-00	3 - 9	5LB-14321-00	8 - 3	5EK-15410-00	11 - 1	4JG-18513-00	15 - 12	4AA-22259-70	21 - 4	2JX-23435-00-35	22 - 9
36X-11631-00-A0	3 - 8	4JP-14323-00	8 - 27	15A-15431-01	11 - 15	3GX-18531-00	15 - 13	34X-22311-00	20 - 12	1E6-23441-10-35	22 - 10
15A-11633-00	3 - 10	4KN-1432A-00	8 - 32	15A-15441-00	2 - 7	3GX-18535-00	15 - 14	5FY-23102-20	23 - 1	30X-23445-00	22 - 15
36X-11636-00	3 - 8	2JX-14333-00	8 - 4	3AW-15451-03	11 - 3	5N0-18540-00	15 - 1	5FY-23103-20	23 - 17	164-23462-00	23 - 35
36X-11638-00	3 - 8	5FY-14336-00	8 - 9	4BE-15462-00	11 - 16	136-18542-00	15 - 2	2JX-23110-00	23 - 7	3TB-23467-01	30 - 13
15A-11651-00	3 - 6	5LB-14336-00	8 - 9	2HT-15512-00	12 - 22	5FY-21110-61	17 - 1		23 - 23	5VX-2411B-00	24 - 3
5H0-11681-00	3 - 4	5LB-14341-00	8 - 12	5H0-15517-00	12 - 25	5GK-2118K-00	24 - 22	2JN-23111-00	23 - 11	2JX-24141-00	24 - 21
5H0-12111-02	4 - 1	5LB-14341-10	8 - 13	5H0-15521-00	12 - 24	5GK-2118K-10	24 - 23		23 - 27	22W-24181-00	9 - 14
11H-12113-00	4 - 4	5LB-14342-65	8 - 15	4H7-15580-10	12 - 27	2JX-21190-00-P1	17 - 25	3J2-23114-00	23 - 12	4L0-24181-00	24 - 4
11H-12114-00	4 - 5	5FY-14343-63	8 - 14	1J7-15583-01	12 - 29	4R8-21308-01	17 - 22		23 - 28	30X-24182-01	24 - 5
4G0-12116-01	4 - 3	288-14343-66	8 - 14	54G-15620-01	12 - 15	5VC-21315-00	17 - 6	22U-23118-01	23 - 13	30X-24183-01	24 - 6
4G0-12117-00	4 - 7	5LB-1434A-00	8 - 6	54G-15621-00	12 - 16	1RL-21316-00-P2	17 - 3		23 - 29	30X-24186-01	24 - 7
4G0-12118-00	4 - 8	50M-14355-00	8 - 21	36X-15641-00	12 - 8	1RL-21337-00	17 - 14	51Y-23125-00	23 - 5	30X-24187-00	24 - 8
5H0-12119-00	4 - 6	5LB-14357-00	8 - 5	15A-15651-01	12 - 12	1RL-21471-00-35	17 - 16		23 - 21	10D-24240-20	24 - 2
5H0-12121-01	4 - 2	5LB-14368-00	8 - 17	15A-15660-01	12 - 1	34L-21485-00	17 - 18	5RS-23126-10	23 - 2	23F-24500-11	24 - 12
5H0-12146-00	4 - 11	5FY-14371-00	8 - 22	15A-15666-00	12 - 4	2YG-21511-00	18 - 1	5RS-23136-10	23 - 18	4X8-24512-00	24 - 13
36X-12151-00	4 - 9	5LB-14384-00	8 - 26	401-15676-00	12 - 3	2JX-21512-00	18 - 2	2JX-23141-00	23 - 10	3AC-24523-00	24 - 15
5H0-12156-00	4 - 10	5LB-14385-00	8 - 23	5H0-16111-00	13 - 1	5PA-21568-01	24 - 22		23 - 26	3AJ-24534-01	24 - 16
2NX-12159-00	4 - 13	5LB-14386-00	8 - 24	15A-16150-00	13 - 5	3AW-21611-20	18 - 9	54G-23144-00	23 - 6	214-24535-00	8 - 20
36X-12171-00	5 - 1	5LB-14390-00	8 - 25	5H0-16154-00	13 - 6	4G0-21639-00	18 - 16		23 - 22	11H-24602-03	24 - 11
1KH-12176-00	5 - 2	2JX-14411-02	7 - 5	537-16321-00	13 - 8	2JX-21641-00	18 - 14	22W-23145-L0	23 - 4	18A-24723-00	25 - 4
3GC-12210-10	5 - 10	2JX-14412-00	7 - 8	137-16324-00	13 - 9	2JX-21651-10	18 - 19		23 - 20	2JX-24731-C0	25 - 2
4FM-12213-00	5 - 11	2JX-14422-00	7 - 13	5H0-16351-00	13 - 10	10D-21660-20	18 - 23	3DM-23149-10	23 - 14	2JX-24734-B0	25 - 3
5H0-12231-00	5 - 8	2JL-14437-00	7 - 7	2JX-16356-00	13 - 14	10D-21668-00	18 - 7		23 - 30	1L9-24741-A0	25 - 5
5N0-12241-00	5 - 9	34X-1443E-00	7 - 16	5H0-16357-00	13 - 24	10D-21668-10	18 - 8	22W-23153-L0	23 - 3	5VC-24770-10	25 - 1

NUMERICAL INDEX

PART NO.	REF. NO.	PART NO.	REF. NO.	PART NO.	REF. NO.	PART NO.	REF. NO.	PART NO.	REF. NO.	PART NO.	REF. NO.
3MX-24875-A0	18 - 24	5LB-26302-02	29 - 6	5VC-82530-00	40 - 35	30X-84196-00	37 - 10	90109-100E2	21 - 5	90201-05033	36 - 8
3MX-24875-B0	18 - 25	5EK-26335-00	29 - 8	4GY-82540-10	40 - 17	10V-84198-00	37 - 11	90109-10473	31 - 26	90201-06057	25 - 6
3TB-24877-A0	18 - 26	1E6-26342-00	29 - 11	5VC-82541-10	40 - 34	2F9-84314-00	37 - 3	90111-10004	31 - 22	90201-06557	38 - 12
3TB-24877-B1	18 - 27	1E6-26372-00	29 - 12	3LD-82566-60	40 - 36	5FY-84320-00	37 - 2	90119-05059	20 - 13	90201-08326	9 - 22
5EK-25111-00	26 - 1	1T5-26372-00	39 - 13	5FY-82590-20	40 - 5	5G2-84324-A0	37 - 9	90119-05062	20 - 16		9 - 24
152-25115-00	28 - 3	128-27114-00	17 - 17	1UA-82591-00	30 - 10	5G2-84332-60	37 - 7	90119-06056	7 - 20	90201-08366	17 - 5
322-25118-00	26 - 11	4NO-27114-00	17 - 19		40 - 8	198-84334-60	37 - 8		18 - 13		17 - 9
5V7-2511E-00-35	28 - 6	2JX-27211-00-90	31 - 1		40 - 10	2F9-84375-00	37 - 4		19 - 10		17 - 13
2N3-25155-00	28 - 14	2JX-27231-00	31 - 4		40 - 12	2F9-84397-01	37 - 5	90119-06063	7 - 21	90201-083A0	38 - 9
2JX-25181-10	26 - 13	1M1-27244-00	31 - 9	341-82594-00	40 - 9	1M1-84521-60	38 - 2		18 - 11	90201-08609	1 - 10
54G-25185-00	28 - 7	2JX-27311-02	31 - 23	1LN-82911-00	39 - 3	1M1-84523-60	38 - 3		25 - 9	90201-086P8	28 - 28
50W-25188-00	21 - 8	5RS-27315-00	31 - 25	33G-82913-01	39 - 4	1M1-84524-60	38 - 5	90123-08046	29 - 9	90201-100E9	21 - 7
5EK-25190-00	26 - 15	2JX-27410-00-90	31 - 13	4GY-82917-01	39 - 8	36A-84551-00	38 - 10	90149-06011	24 - 17	90201-10118	30 - 12
4TP-25304-10	26 - 6	15A-27420-02-90	31 - 18	1UF-83310-00	35 - 1	1W9-84710-61	38 - 1	90149-06131	39 - 17	90201-10508	3 - 29
2JX-25304-21	28 - 20	120-27431-00	31 - 33	256-83311-70	35 - 11	256-84714-61	35 - 3	90149-06228	40 - 33	90201-10591	5 - 5
2JX-25311-00	28 - 1	5RS-27432-01	31 - 29		35 - 15		35 - 7	90149-08067	13 - 22	90201-120E8	20 - 10
2JX-25321-02-35	28 - 10	120-27433-00	31 - 32	1UF-83320-00	35 - 5		38 - 4	90151-06013	15 - 7	90201-12588	16 - 5
2JX-25336-00	28 - 9	2JX-27437-00	31 - 31	1UF-83330-00	35 - 9	4L0-84753-00	38 - 6	90151-06018	17 - 23	90201-12749	21 - 10
2JX-2533A-00	28 - 18	2JX-27442-11	31 - 28	51L-83332-00	35 - 14	20G-85110-00	40 - 43	90152-06010	12 - 19	90201-14740	26 - 12
3Y6-25351-00	28 - 13	3MA-27491-00	17 - 28	51L-83332-01	35 - 2	49R-85112-00	23 - 40	90153-06001	40 - 27	90201-164H4	28 - 36
36R-25367-00	28 - 31		20 - 21	1UF-83340-00	35 - 13	3G1-85130-01	38 - 14	90153-06029	1 - 3	90201-17257	14 - 19
2JX-25381-10	28 - 34	5VC-28100-00	17 - 29	51L-83342-00	35 - 10	4WP-85510-10	33 - 2	90154-05004	18 - 3	90201-173F4	12 - 11
3Y1-25388-01	28 - 32	10D-2815N-00	19 - 13	51L-83342-01	35 - 6	5LB-85540-01	40 - 1	90154-05005	7 - 15	90201-175F6	12 - 7
3Y1-25389-00	28 - 33	10D-2815N-10	19 - 14	4MY-83350-01	40 - 42	5BT-85550-01	33 - 1	90154-05013	19 - 2	90201-201E4	3 - 12
3HT-25398-00	28 - 29	3AW-28351-20	32 - 1	10V-83365-00	35 - 18	4JG-85580-01	33 - 3	90157-05008	40 - 37	90201-20279	31 - 34
15A-25450-20	28 - 24	10D-28390-20	32 - 4	18G-83365-00	35 - 19	5CG-W0041-00	30 - 2	90159-05011	13 - 12	90201-220J8	14 - 21
5LB-2580T-01	27 - 3	3JJ-28446-A1	18 - 28	5LB-83371-11	40 - 40	5LB-W0045-01	27 - 8	90159-05028	18 - 15	90201-25290	12 - 26
5XT-2582T-00	27 - 1	3JJ-28446-B1	18 - 29	15A-83509-00	36 - 11	4JG-W0047-00	27 - 5	90159-06060	32 - 3	90202-05191	9 - 8
4GY-25852-01	30 - 4	50M-81801-M0	34 - 2	4CS-83510-00	36 - 1	51L-W0048-00	27 - 10	90164-04008	36 - 10	90202-05193	24 - 18
5RB-25854-00	30 - 3	59V-81828-M0	34 - 5	5Y1-83513-00	36 - 5	4JG-W0057-00	27 - 4	90170-06010	39 - 18	90206-06090	9 - 10
3RW-25867-00	30 - 6	4JG-8183G-00	34 - 6	123-83516-21	36 - 12	4KN-W253E-11	28 - 11	90170-06128	4 - 14	90209-06187	20 - 15
5RS-25870-01	30 - 1	2JX-81890-00	34 - 1	4R0-83517-00	36 - 3	5RS-Y2410-10-X8	24 - 1	90170-14284	3 - 27	90209-08125	38 - 7
5RS-25872-00	30 - 9	5EK-81940-02	40 - 21	15A-83519-00	36 - 6	90101-06278	28 - 15		13 - 4	90209-16209	14 - 3
34X-25876-00	30 - 19	29U-81950-93	40 - 38	437-83525-00	36 - 9	90101-10188	3 - 30		13 - 19	90209-17226	12 - 9
5RS-25886-00	30 - 17	3TJ-81960-02	40 - 19	1M1-83526-00	36 - 7	90101-10303	5 - 4	90175-06013	31 - 12	90209-18208	14 - 16
36Y-2589H-00	30 - 5	3WP-81980-00	40 - 6	2JX-83536-A0	36 - 2	90105-06014	11 - 7	90179-08148	29 - 10	90214-17028	12 - 13
5JW-25914-10	27 - 6	1JE-82110-61	40 - 24	5LB-83550-00	36 - 14	90105-06017	11 - 6	90179-08410	28 - 8	90214-20023	3 - 17
4TT-25919-00	27 - 9	5LB-82115-00	40 - 30	5EK-83568-00	36 - 4	90105-065A1	6 - 16	90179-25002	22 - 7	90215-06184	1 - 21
4TT-25937-00	27 - 7	5EK-82116-02	40 - 31	4GY-83912-00	39 - 5	90105-08066	17 - 10	90185-08055	17 - 15	90215-08160	28 - 27
5LB-26111-00	29 - 1	51Y-82122-00	40 - 25	55Y-83922-00	39 - 14	90105-08117	1 - 9	90185-08089	17 - 4	90215-14186	13 - 18
1LX-26241-01	29 - 5	116-82131-00	19 - 12	25G-83936-01	40 - 11	90105-10638	27 - 11		17 - 8	90215-14205	3 - 26
1LX-26242-01	29 - 2	18G-82131-00	40 - 29	437-83936-01	39 - 21	90105-14102	22 - 8		17 - 12		13 - 3
5BE-26243-00	29 - 3	3TJ-82131-00	17 - 30	4CS-83973-00	39 - 1	90109-06005	38 - 8		28 - 26	90240-06076	31 - 5
3Y1-26249-00	29 - 4	2GH-82151-00	40 - 22	5LB-83975-01	39 - 11	90109-06419	6 - 13	90185-10037	31 - 27	90240-07083	3 - 18
3LN-26281-01	29 - 15	5LB-8215C-00	40 - 26	3DM-83980-00	39 - 20	90109-06577	39 - 15	90185-12134	20 - 11	90240-12075	21 - 9
3LN-26282-01	29 - 16	3RW-82310-10	40 - 2	47J-84115-00	37 - 1	90109-065G4	27 - 2	90185-16127	28 - 35	90249-12008	31 - 11
3Y1-26290-00	29 - 14	1UY-82370-20	40 - 4	43F-84131-00	37 - 6	90109-06799	39 - 6	90201-04018	19 - 8	90267-40075	19 - 7
3Y1-26290-10	29 - 13	5LB-82501-01	40 - 32	2RR-84178-00	37 - 12	90109-08618	28 - 25	90201-05015	9 - 4	90280-05013	3 - 28

NUMERICAL INDEX

PART NO.	REF. NO.	PART NO.	REF. NO.	PART NO.	REF. NO.	PART NO.	REF. NO.	PART NO.	REF. NO.	PART NO.	REF. NO.
90282-05013	3 - 25	90467-11106	7 - 17	91701-06032	31 - 35	93306-30427	3 - 23	95027-06085	10 - 9	98507-04018	30 - 14
90282-05043	13 - 2	90467-14015	10 - 12	91701-08038	31 - 15		3 - 24	95027-06090	10 - 8	98507-05008	34 - 7
90338-08007	7 - 23	90468-26122	12 - 2		31 - 20	93306-30611	3 - 7	95307-05600	22 - 19	98507-05018	22 - 17
90338-12081	17 - 27	90480-01141	19 - 11	92017-08016	31 - 30	93310-530J3	3 - 5	95307-06600	13 - 17		39 - 12
90338-12192	18 - 5	90480-12053	18 - 10	92907-04600	30 - 15	93315-23607	15 - 3		28 - 16	98507-05020	29 - 17
90338-18014	12 - 20		32 - 2	92907-05100	34 - 8	93410-20038	14 - 4	95307-06700	31 - 3		39 - 9
90340-14117	11 - 8	90480-12299	17 - 24		39 - 10	93410-22039	14 - 17	95307-12700	35 - 17	98507-05025	29 - 18
90340-32080	11 - 10	90480-13197	19 - 9	92907-05600	22 - 18	93420-28055	13 - 28	95607-05200	18 - 4	98507-05030	39 - 2
90380-12051	21 - 2	90480-14023	37 - 15	92907-06100	25 - 8	93440-10085	1 - 2	95607-06100	38 - 13	98507-06010	9 - 16
90380-18139	20 - 5	90501-04596	12 - 28	92907-06200	13 - 16	93450-17044	3 - 11		39 - 7		14 - 29
90386-14103	13 - 26	90501-07629	3 - 19		31 - 6	93505-16006	13 - 25		39 - 16	98707-06030	6 - 5
90386-18146	20 - 4	90501-10245	31 - 10	92907-06600	5 - 14	93507-32009	12 - 18	95607-14100	26 - 14	98901-04006	8 - 33
90387-063E6	37 - 14	90501-10312	39 - 19		9 - 17	93602-13177	3 - 20	95617-10100	21 - 6	98907-06010	9 - 5
90387-06681	18 - 21	90501-12081	12 - 17		17 - 21	93603-12030	6 - 3	95707-05500	38 - 15		9 - 9
90387-06737	20 - 18	90501-18576	6 - 7		24 - 10	93604-10011	5 - 3		40 - 44	99001-10600	16 - 4
90387-080K1	9 - 18	90501-21133	3 - 14		30 - 8	93604-16092	15 - 5	95807-06012	22 - 14	99009-17400	12 - 6
90387-125F1	10 - 5	90501-23700	13 - 11	92907-08600	9 - 13	93604-20156	15 - 6		30 - 18		12 - 14
	10 - 6	90506-08227	16 - 2	93101-15101	14 - 9	93605-10090	3 - 15		40 - 41		14 - 20
90387-125Y0	12 - 23	90506-15260	28 - 12	93102-12106	16 - 7	93608-50158	16 - 6	95807-06016	38 - 11		14 - 33
90387-15600	26 - 10	90506-18289	31 - 8	93102-14209	13 - 27	93615-12088	12 - 30	95807-06020	18 - 6	99244-00080	18 - 22
90387-171T1	28 - 17	90506-29360	31 - 24	93102-17187	14 - 30	93700-06009	20 - 20		20 - 19	99244-00100	32 - 5
90387-171T2	28 - 30	90508-18537	13 - 23	93102-17263	12 - 10	93823-14149	14 - 25	95807-06040	36 - 13	99530-12016	10 - 2
90387-255F3	5 - 6	90508-20023	31 - 14	93102-20281	26 - 4	94113-184R7	26 - 7	95817-08016	9 - 23		11 - 4
90401-10159	30 - 11		31 - 19	93102-22389	14 - 23	94118-145U1	28 - 21	95817-08050	17 - 7		11 - 17
90430-06014	1 - 4	90508-26538	12 - 5	93102-25311	28 - 5	94213-18232	26 - 8	95817-08065	17 - 2	99530-14016	1 - 7
	10 - 10	90508-26539	15 - 9	93109-18020	20 - 6	94218-14251	28 - 22	95817-08120	17 - 11		2 - 5
90430-08119	13 - 21	90508-29540	16 - 3	93210-07135	6 - 14	94318-14149	28 - 23	95824-08035	22 - 11		
90430-10148	40 - 18	90560-15312	26 - 3	93210-09165	4 - 12	94340-18086	26 - 9	95827-06012	17 - 26		
90430-14131	1 - 8	90560-17305	28 - 2	93210-13361	2 - 4	94425-18002	26 - 5	95827-12025	31 - 17		
90445-057G5	30 - 16	90560-17368	14 - 32	93210-14369	11 - 9	94445-14605	28 - 19	97007-05010	14 - 27		
90445-082F3	40 - 28	91317-06010	11 - 13	93210-19123	11 - 22	94580-41104	5 - 7	97007-06012	1 - 20		
90445-10007	24 - 19		30 - 20	93210-25711	34 - 3	94580-88122	28 - 37		24 - 9		
90445-10041	24 - 19	91317-06018	1 - 18	93210-32172	11 - 11	94680-88001	28 - 38	97007-06016	17 - 20		
90446-15377	40 - 15	91317-06020	7 - 3	93210-347A1	6 - 9	94701-00222	1 - 22	97007-06020	31 - 2		
90450-44062	7 - 4		9 - 20	93210-35537	7 - 2	94701-00333	1 - 22	97007-06025	30 - 7		
90460-51059	7 - 19		33 - 5	93210-48364	13 - 15	95024-06014	18 - 20		37 - 13		
90462-08224	10 - 15	91317-06025	5 - 12	93210-54175	6 - 12	95024-08050	22 - 12	97017-06020	25 - 7		
90462-08225	10 - 14		33 - 4	93210-55669	34 - 4	95027-06008	40 - 23	97027-06016	5 - 13		
	11 - 24	91317-06030	2 - 6	93210-57634	1 - 17	95027-06016	40 - 3	97027-06020	16 - 10		
90464-06214	29 - 7	91317-08020	9 - 21	93210-72529	2 - 2	95027-06020	1 - 14	97027-08030	12 - 21		
90464-13004	40 - 39		12 - 31	93211-05471	1 - 13	95027-06025	6 - 15	97702-50525	7 - 18		
90465-08020	10 - 13	91317-08025	9 - 12	93306-20201	14 - 10		11 - 5	97706-40620	35 - 12		
90465-08127	10 - 16	91317-08045	1 - 11	93306-20203	26 - 2		11 - 18		35 - 16		
90465-08364	11 - 12	91401-20012	31 - 7	93306-20313	14 - 31		40 - 20	97707-40620	35 - 4		
90465-10098	40 - 16		31 - 36	93306-20332	14 - 24	95027-06030	10 - 7		35 - 8		
90465-16187	11 - 14	91401-25015	31 - 16	93306-20348	28 - 4	95027-06035	11 - 19	97707-50520	7 - 10		
90467-09006	24 - 20		31 - 21	93306-20401	14 - 8	95027-06040	10 - 4	97801-05010	8 - 2		
90467-10041	7 - 24	91401-30025	21 - 11	93306-20580	14 - 22	95027-06045	11 - 20	98507-03008	24 - 14		