



PARTS CATALOGUE

XT250Y (3C5F) CANADA

XT250Y (3C5G) AUSTRALIA, NEW ZEALAND



1H3C5-100E1



XT250Y
PARTS CATALOGUE
©2008 by Yamaha Motor Co., Ltd.
1st edition, May 2008
All rights reserved.
Any reprinting or unauthorized use
without the written permission of
Yamaha Motor Co., Ltd.
is expressly prohibited.
Printed in Japan.

FOREWORD

This Parts Catalogue is related to the parts for the model(s) on the cover page. When you are ordering replacement parts, please refer to this Parts Catalogue and quote both part numbers and part names correctly.

1. Modifications or additions which have been made after the issue of the Parts Catalogue will be announced in the Parts News.

It is advisable that you make the necessary corrections to the Parts Catalogue according to the Parts News.

2. Abbreviations

The following abbreviations are used in this Parts Catalogue.

“UR” Use specified parts number.

“UN” Use as many as needed.

“AP” Alternate Parts

“LM” Locally Made (Parts need to be ordered locally)

“F#” Frame No. (Applicable machine No.)

“O/S” Over Size

3. The number of components for assembly

- Parts, which are to be supplied in an assembly, are listed with a dot (.) in front of the part name as shown below.
- The numeral appearing to the right of each component part indicates the quantity of parts for each assembly unit.

PART NO.	DESCRIPTION	Q'TY	REMARKS
2F5-83310-60	FRONT FLASHER LIGHT ASSY	2	
115-83311-60	.BULB (6V-18W)	1	

4. Applicable colours of graphics are represented in the “REMARKS” as shown below.

PART NO.	DESCRIPTION	Q'TY	REMARKS
2N4-24110-00-X5	FUEL TANK COMP.	2	MXR
3J1-24240-10	.GRAPHIC, FUEL TANK	1	FOR MXR

5. Note that the illustrations for reference in finding parts numbers are not to be used for assembling. When assembling, please use the applicable service manual.

6. The asterisk (*) before a reference number indicates modified items after the first edition.

CONTENTS

ENGINE

CYLINDER HEAD	1
CYLINDER	3
CRANKSHAFT & PISTON	4
VALVE	6
CAMSHAFT & CHAIN	7
OIL PUMP	8
INTAKE	9
CARBURETOR	11
EXHAUST	13
CRANKCASE	15
CRANKCASE COVER 1	16
STARTER CLUTCH	18
CLUTCH	19
TRANSMISSION	21
SHIFT CAM & FORK	22
SHIFT SHAFT	23

CHASSIS

FRAME	24
FENDER	26
SIDE COVER	28
REAR ARM	29
REAR SUSPENSION	31
STEERING	32
FRONT FORK	33
FUEL TANK	35
SEAT	37
FRONT WHEEL	38
FRONT BRAKE CALIPER	39
REAR WHEEL	40
REAR WHEEL 2	41
REAR BRAKE CALIPER	42
STEERING HANDLE & CABLE	43
FRONT MASTER CYLINDER	44
STAND & FOOTREST	45
REAR MASTER CYLINDER	46
GENERATOR	48
STARTING MOTOR	49
FLASHER LIGHT	50
FLASHER LIGHT 2	51
METER	52

HEADLIGHT	53
TAILLIGHT	55
HANDLE SWITCH & LEVER	56
ELECTRICAL 1	57
ELECTRICAL 2	59

INDEX

NUMERICAL INDEX	60
-----------------------	----

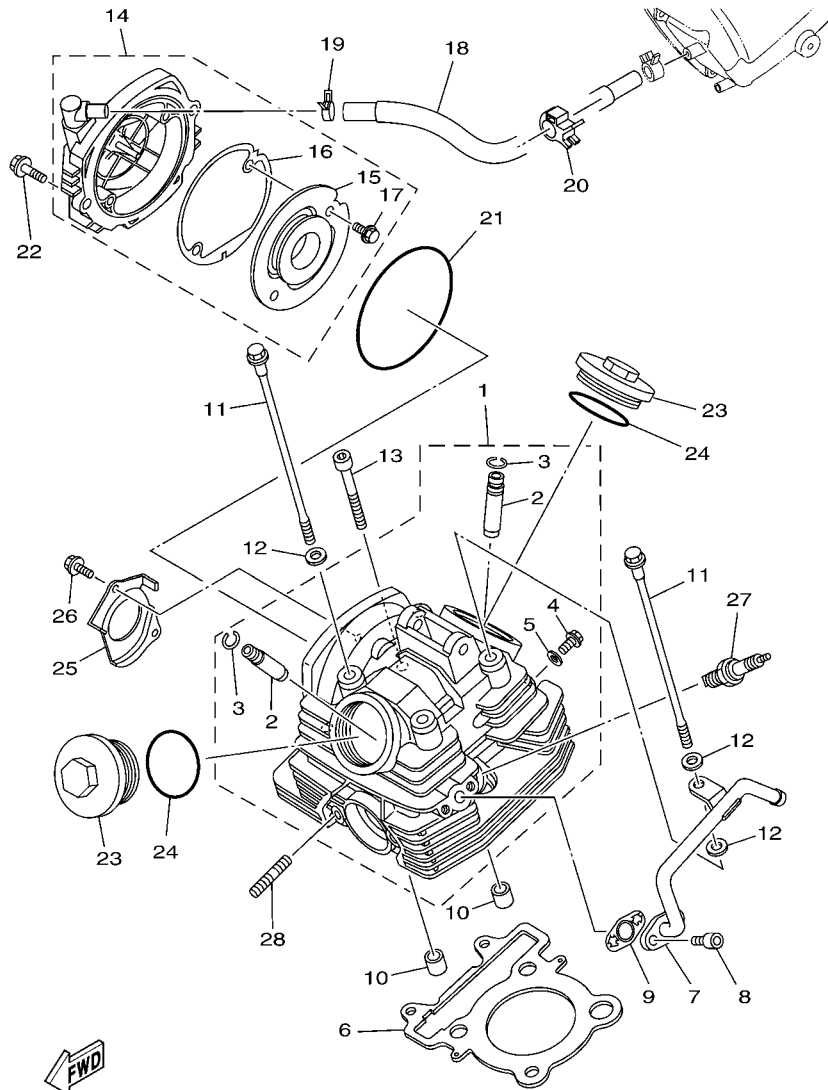

5XT1010-C010

FIG. 1 CYLINDER HEAD

REF. NO.	PART NO.	DESCRIPTION	3C5F	3C5G	REMARKS
1	3C5-11102-00	CYLINDER HEAD ASSY	1	1	
2	5H0-11133-11	.GUIDE, VALVE 1	2	2	
3	93440-10085	.CIRCLIP	2	2	
4	90153-06002	.SCREW, HEXAGON	1	1	
5	90430-06014	.GASKET	1	1	
6	5XT-11181-00	GASKET, CYLINDER HEAD 1	1	1	
7	3C5-14871-00	PIPE 1	1	1	
8	91314-06016	BOLT, HEXAGON SOCKET HEAD	2	2	
9	5XT-14815-00	GASKET	1	1	
10	99530-14016	PIN, DOWEL	2	2	
11	90105-08160	BOLT, FLANGE	4	4	
12	90201-08609	WASHER, PLATE	5	5	
13	91314-08045	BOLT, HEXAGON SOCKET HEAD	2	2	
14	5XT-11190-10	COVER, CYLINDER HEAD 1	1	1	
15	5XT-11165-00	.PLATE, BREATHER	1	1	
16	5XT-11196-00	.GASKET, CYLINDER HEAD SIDE	1	1	
17	90105-06126	.BOLT, FLANGE	2	2	
18	5C1-11166-00	PIPE, BREATHER 1	1	1	
19	90467-12053	CLIP	1	1	
20	90464-15192	CLAMP	1	1	
21	93211-05471	O-RING	1	1	
22	95024-06020	BOLT, FLANGE	2	2	
23	5XT-11186-00	COVER, CYLINDER HEAD SIDE 2	2	2	
24	93210-54001	O-RING	2	2	
25	5XT-1111F-00	PLATE	1	1	
26	90105-06078	BOLT, FLANGE	2	2	
27	94701-00345	PLUG, SPARK (NGK DR7EA)	1	1	WITH RESISTER

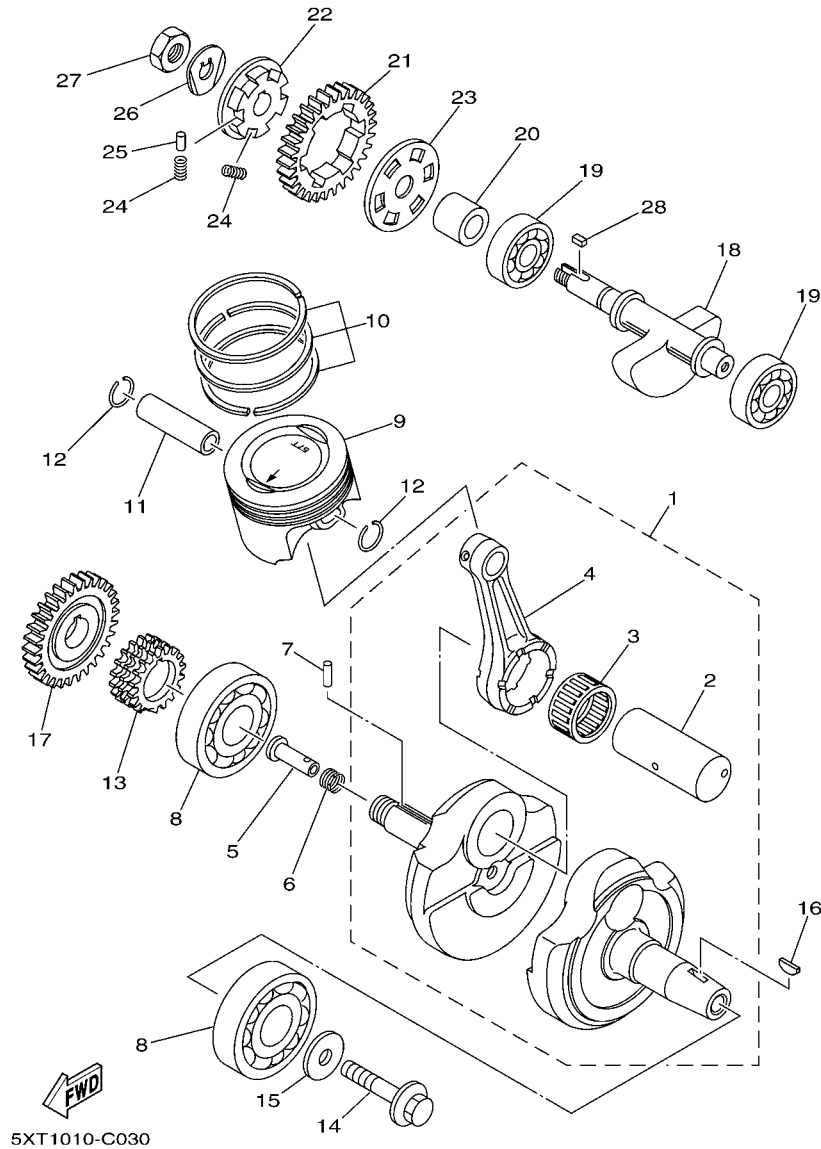
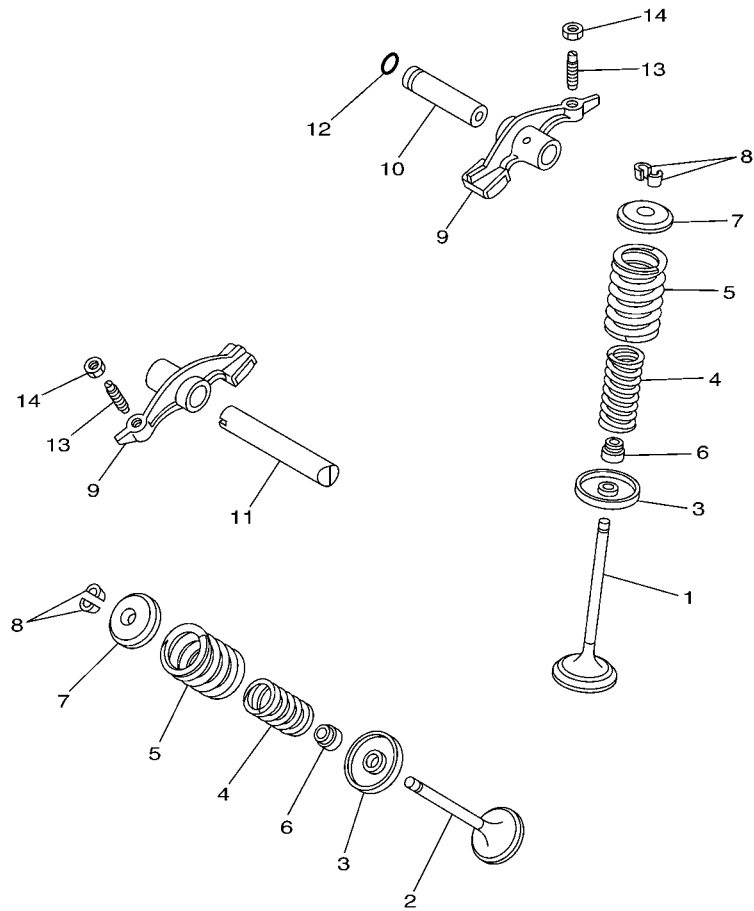

FIG. 3 CRANKSHAFT & PISTON

REF. NO.	PART NO.	DESCRIPTION	3C5F	3C5G	REMARKS
1	5XT-11400-00	CRANKSHAFT ASSY	1	1	
2	5BP-11681-00	.PIN, CRANK 1	1	1	
3	93310-530J3	.BEARING	1	1	
4	29U-11651-00	.ROD, CONNECTING	1	1	
5	90240-07105	PIN, CLEVIS	1	1	
6	90501-07629	SPRING, COMPRESSION	1	1	
7	93602-13177	PIN, DOWEL	1	1	
8	93306-37814	BEARING	2	2	
9	3C5-11631-00-A0	PISTON (STD)	1	1	
10	4XV-11603-00	PISTON RING SET (STD)	1	1	
11	5H0-11633-00	PIN, PISTON	1	1	
12	93450-17044	CIRCLIP	2	2	
13	5BP-11549-00	SPROCKET, CAM CHAIN	1	1	
14	90105-10430	BOLT, FLANGE	1	1	
15	90201-102R1	WASHER, PLATE	1	1	
16	90280-05013	KEY, WOODRUFF	1	1	
17	1S4-11536-00	GEAR, DRIVE	1	1	
18	5XT-11454-00	WEIGHT 1	1	1	
19	93306-30214	BEARING	2	2	
20	5XT-11478-00	COLLAR	1	1	
21	1S4-11531-00	GEAR, BALANCE WEIGHT	1	1	
22	5XT-11496-00	BOSS, BUFFER	1	1	
23	5XT-11533-00	PLATE, ABSORBER	1	1	
24	90501-22721	SPRING, COMPRESSION	6	6	
25	93605-10090	PIN, DOWEL	3	3	
26	90215-12272	WASHER, LOCK	1	1	
27	90170-12370	NUT	1	1	



5BP1460-1040

FIG. 4 VALVE

REF. NO.	PART NO.	DESCRIPTION	3C5F	3C5G	REMARKS
1	5H0-12111-02	VALVE, INTAKE	1	1	
2	5XT-12121-00	VALVE, EXHAUST	1	1	
3	4G0-12116-01	SEAT, VALVE SPRING	2	2	
4	11H-12113-00	SPRING, VALVE INNER	2	2	
5	11H-12114-00	SPRING, VALVE OUTER	2	2	
6	5H0-12119-00	SEAL, VALVE STEM	2	2	
7	4G0-12117-00	RETAINER, VALVE SPRING	2	2	
8	4G0-12118-00	COTTER, VALVE	4	4	
9	36X-12151-00	ARM, VALVE ROCKER	2	2	
10	5H0-12156-00	SHAFT, ROCKER 2	1	1	
11	5H0-12146-00	SHAFT, ROCKER	1	1	
12	93210-09165	O-RING	1	1	
13	5XT-12159-00	SCREW, VALVE ADJUSTING	2	2	
14	90170-06128	NUT	2	2	

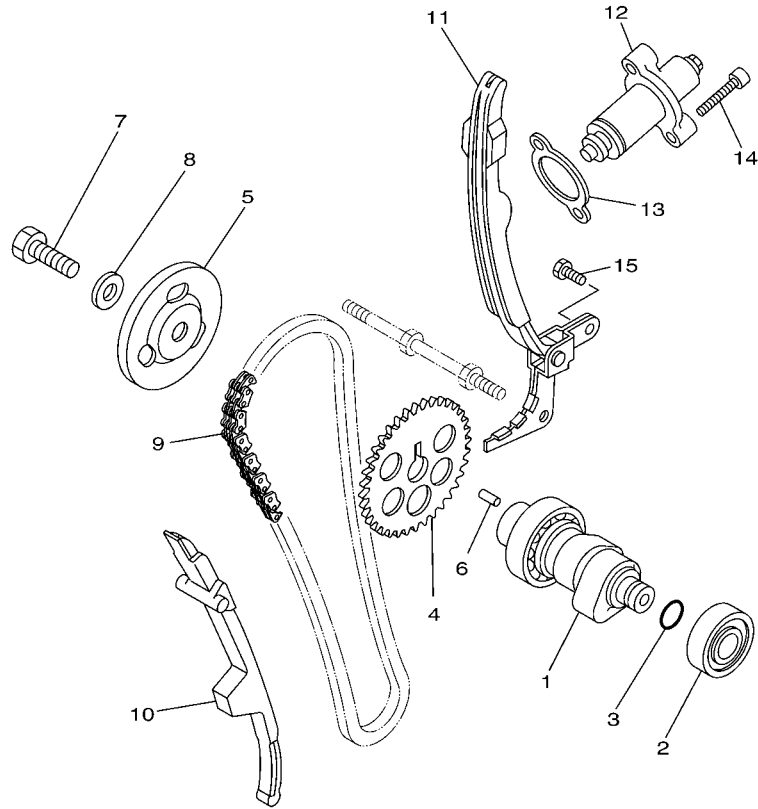

 5XT1010-C050

FIG. 5 CAMSHAFT & CHAIN

REF. NO.	PART NO.	DESCRIPTION	3C5F	3C5G	REMARKS
1	5XT-12170-00	CAMSHAFT ASSY 1	1	1	
2	93306-20204	BEARING	1	1	KOYO
3	93210-11453	O-RING	1	1	
4	5XT-12176-00	SPROCKET, CAM CHAIN	1	1	
5	4KB-11145-00	PLATE, BREATHER 2	1	1	
6	93604-10011	PIN, DOWEL	1	1	
7	90101-10016	BOLT	1	1	
8	90201-10591	WASHER, PLATE	1	1	
9	94582-19104	CHAIN (DID SCR-0404 SV 104LE)	1	1	
10	5BP-12231-00	GUIDE, STOPPER 1	1	1	
11	5XT-12241-00	GUIDE, STOPPER 2	1	1	
12	5XT-12210-00	TENSIONER ASSY, CAM CHAIN	1	1	
13	4FM-12213-00	GASKET, TENSIONER CASE	1	1	
14	91314-06025	BOLT, HEXAGON SOCKET HEAD	2	2	
15	90101-06043	BOLT	2	2	

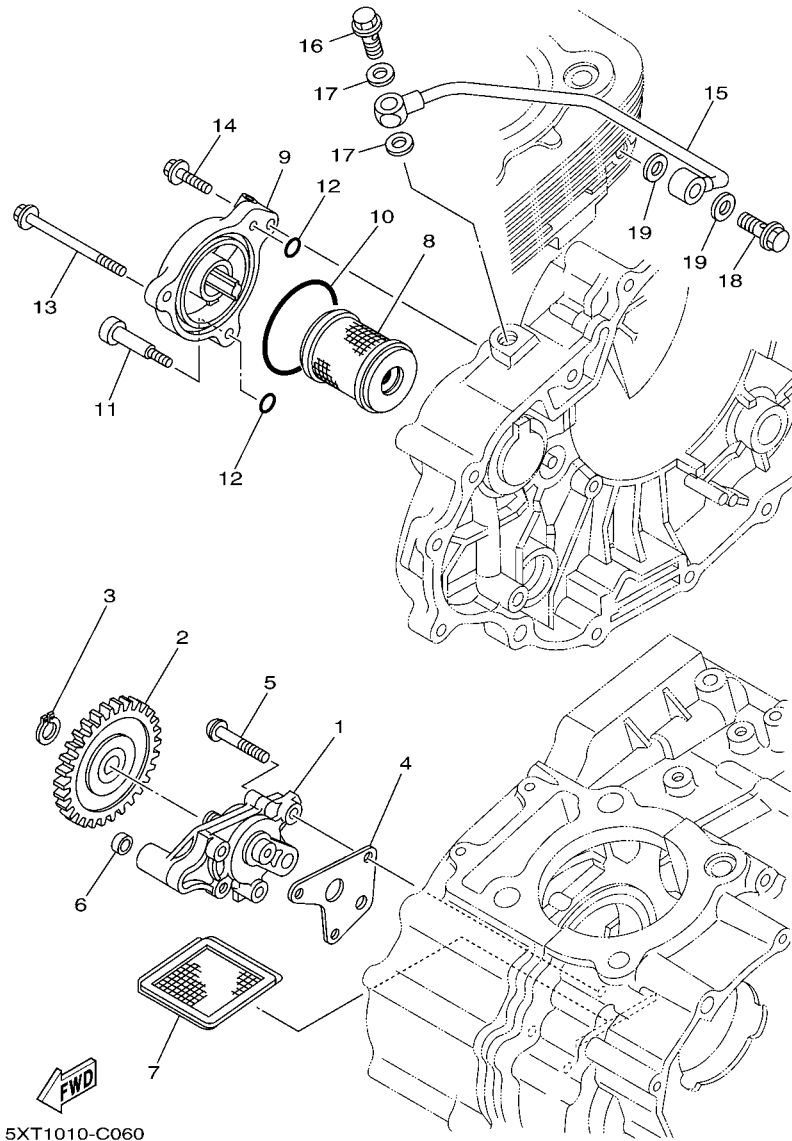

FIG. 6 OIL PUMP

REF. NO.	PART NO.	DESCRIPTION	3C5F	3C5G	REMARKS
1	5XT-13300-01	OIL PUMP ASSY	1	1	
2	5BP-13326-01	GEAR, PUMP DRIVEN 2 (38T)	1	1	
3	99009-11400	CIRCLIP	1	1	
4	5XT-13329-00	GASKET, PUMP COVER	1	1	
5	90149-06093	SCREW	3	3	
6	90430-06156	GASKET	1	1	
7	22F-13411-01	STRAINER, OIL	1	1	
8	5D3-13440-00	ELEMENT ASSY, OIL CLEANER	1	1	
9	5XT-13447-00	COVER, OIL ELEMENT	1	1	
10	93210-54175	O-RING	1	1	
11	90109-065G0	BOLT	1	1	
12	93210-07135	O-RING	2	2	
13	91314-06070	BOLT, HEXAGON SOCKET HEAD	1	1	
14	91314-06020	BOLT, HEXAGON SOCKET HEAD	1	1	
15	5XT-13161-00	PIPE, DELIVERY 1	1	1	
16	90401-10003	BOLT, UNION	1	1	
17	90430-10171	GASKET	2	2	
18	90401-08007	BOLT, UNION	1	1	
19	90430-08119	GASKET	2	2	

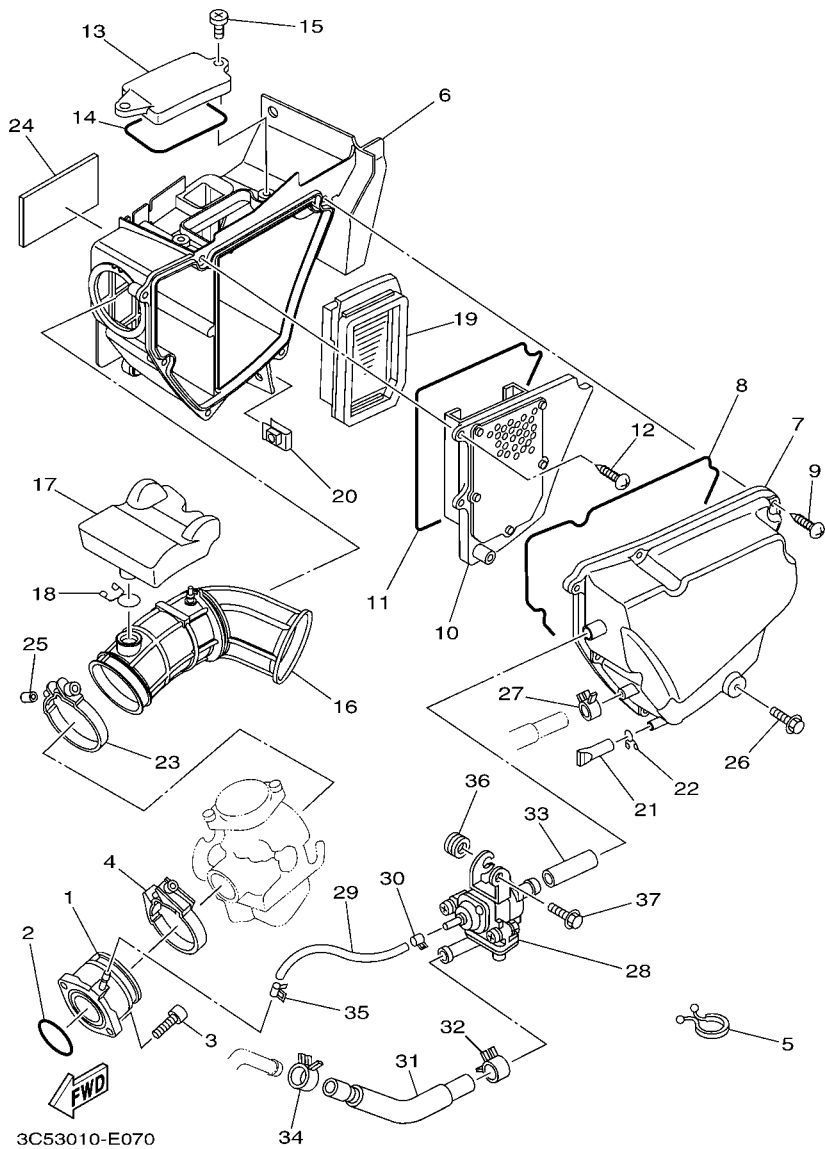

FIG. 7 INTAKE

REF. NO.	PART NO.	DESCRIPTION	3C5F	3C5G	REMARKS
1	5XT-13586-00	JOINT, CARBURETOR 1	1	1	
2	93210-35537	O-RING	1	1	
3	91312-06020	BOLT	2	2	
4	90450-47001	HOSE CLAMP ASSY	1	1	
5	341-82594-00	CLAMP	1	1	
6	5XT-14401-20	AIR CLEANER CASE ASSY	1	1	
7	5XT-14421-01	CASE, AIR CLEANER 2	1	1	
8	5XT-14462-00	SEAL	1	1	
9	97707-50025	SCREW, TAPPING	6	6	
10	5XT-14472-00	PLATE, ELEMENT	1	1	
11	5XT-14452-00	SEAL	1	1	
12	97707-50520	SCREW, TAPPING	2	2	
13	5XT-14412-00	CAP, CLEANER CASE 1	1	1	
14	5XT-14457-00	SEAL	1	1	
15	98907-06012	SCREW, BIND	2	2	
16	5XT-14453-00	JOINT, AIR CLEANER 1	1	1	
17	5XT-13581-00	CHAMBER, AIR	1	1	
18	90467-18196	CLIP	1	1	
19	5XT-14451-00	ELEMENT, AIR CLEANER	1	1	
20	90183-06023	NUT, SPRING	2	2	
21	5XT-1443E-00	PIPE, DRAIN	1	1	
22	90467-11106	CLIP	1	1	
23	90450-56004	HOSE CLAMP ASSY	1	1	
24	5EJ-2414H-00	DAMPER, PLATE 1	1	1	
25	90445-057G5	HOSE (L10)	1	1	
26	90105-06057	BOLT, FLANGE	1	1	
27	90467-12053	CLIP	1	1	

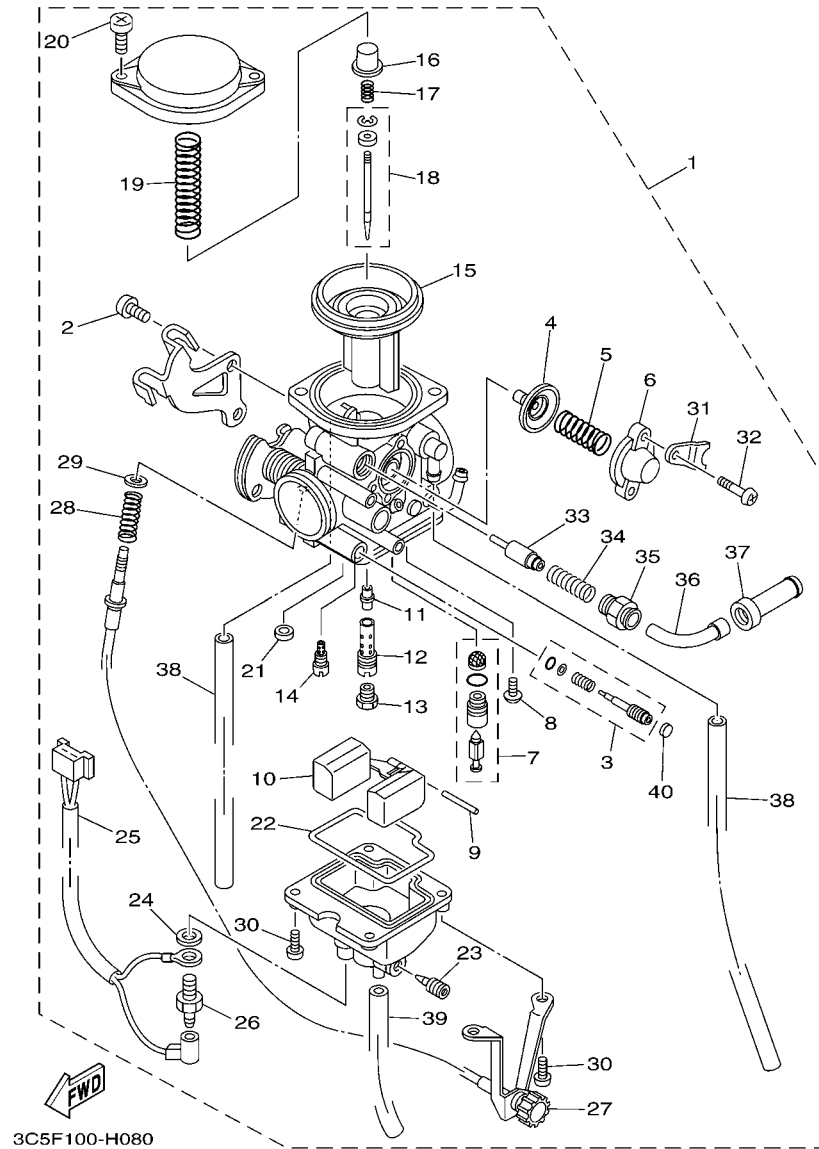

FIG. 8 CARBURETOR

REF. NO.	PART NO.	DESCRIPTION	3C5F	3C5G	REMARKS
1	3C5-14301-11	CARBURETOR ASSY 1	1		
	3C5-14301-20	CARBURETOR ASSY 1		1	
2	5XT-14325-00	.SCREW, PAN HEAD	2		
	97801-05008	.SCREW, PAN HEAD		2	
3	5LB-14105-00	.PILOT SCREW SET	1	1	
4	5LB-14368-00	.DIAPHRAGM ASSY 1	1	1	
5	5LB-14589-00	.SPRING	1	1	
6	5LB-14293-00	.COVER 1	1	1	
7	5XT-14390-10	.NEEDLE VALVE ASSY	1	1	
8	5XT-14325-10	.SCREW, PAN HEAD	2		
	98901-04006	.SCREW, BIND		2	
9	5LB-14386-00	.PIN, FLOAT	1	1	
10	5LB-14385-00	.FLOAT	1	1	
11	5XT-14341-00	.NOZZLE, MAIN	1	1	
12	5XT-14341-10	.NOZZLE, MAIN	1	1	
13	288-14343-68	.JET, MAIN (#135)	1	1	
14	5LB-14342-17	.JET, PILOT (# 34)	1	1	
15	5XT-1434A-00	.SUCTION PISTON ASSY	1	1	
16	5LB-14936-00	.SEAT, SPRING	1	1	
17	5LB-14275-00	.SPRING	1	1	
18	3C5-14336-00	.NEEDLE	1		
	5XT-14336-10	.NEEDLE		1	
19	5XT-14286-00	.SPRING	1	1	
20	5LB-14216-00	.SCREW	2	2	
21	50M-14355-00	.PLUG	1	1	
22	5LB-14384-00	.GASKET, FLOAT CHAMBER	1	1	
23	5XT-14323-00	.SCREW, AIR ADJUSTING	1	1	

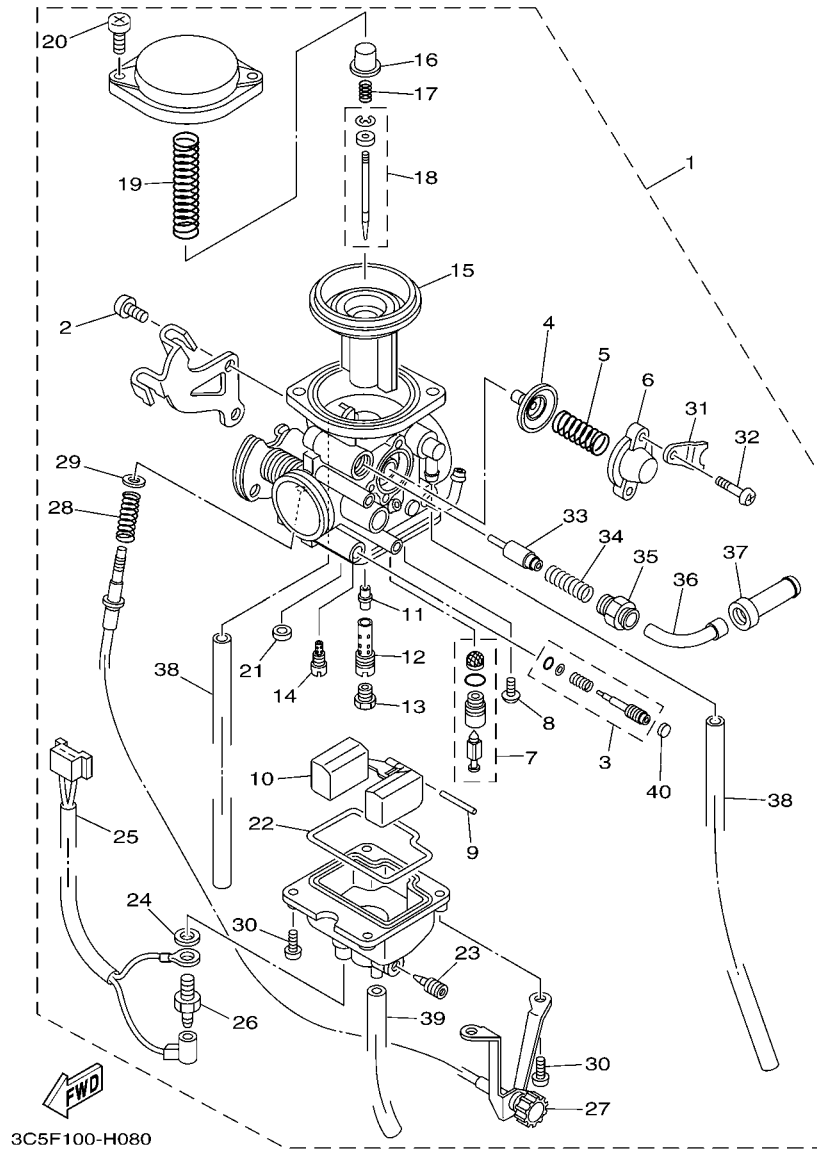

FIG. 8 CARBURETOR

REF. NO.	PART NO.	DESCRIPTION	3C5F	3C5G	REMARKS
24	90201-08016	.WASHER, PLATE	1	1	
25	5XT-82509-00	.WIRE, SUB LEAD	1	1	
26	5FU-83790-00	.HEATER ASSY (15W)	1	1	
27	5XT-14321-00	.SCREW, THROTTLE	1	1	
28	2JX-14333-00	.SPRING, THROTTLE STOP	1	1	
29	5LB-14357-00	.WASHER, PLAIN	1	1	
30	5LB-14592-00	.SCREW	4	4	
31	5XT-14292-00	.BRACKET 2	1	1	
32	214-24535-00	.SCREW, LEVER FITTING	2	2	
33	5XT-14371-10	.PLUNGER, STARTER	1	1	
34	5XT-14335-00	.SPRING, PLUNGER	1	1	
35	5XT-14374-00	.CAP, PLUNGER	1	1	
36	5XT-14348-00	.PIPE 1	1	1	
37	1JK-14363-00	.NUT	1	1	
38	3C5-14148-00	.PIPE	2	2	
39	3C5-14196-00	.PIPE	1	1	
40	3C5-14355-00	.PLUG	1		

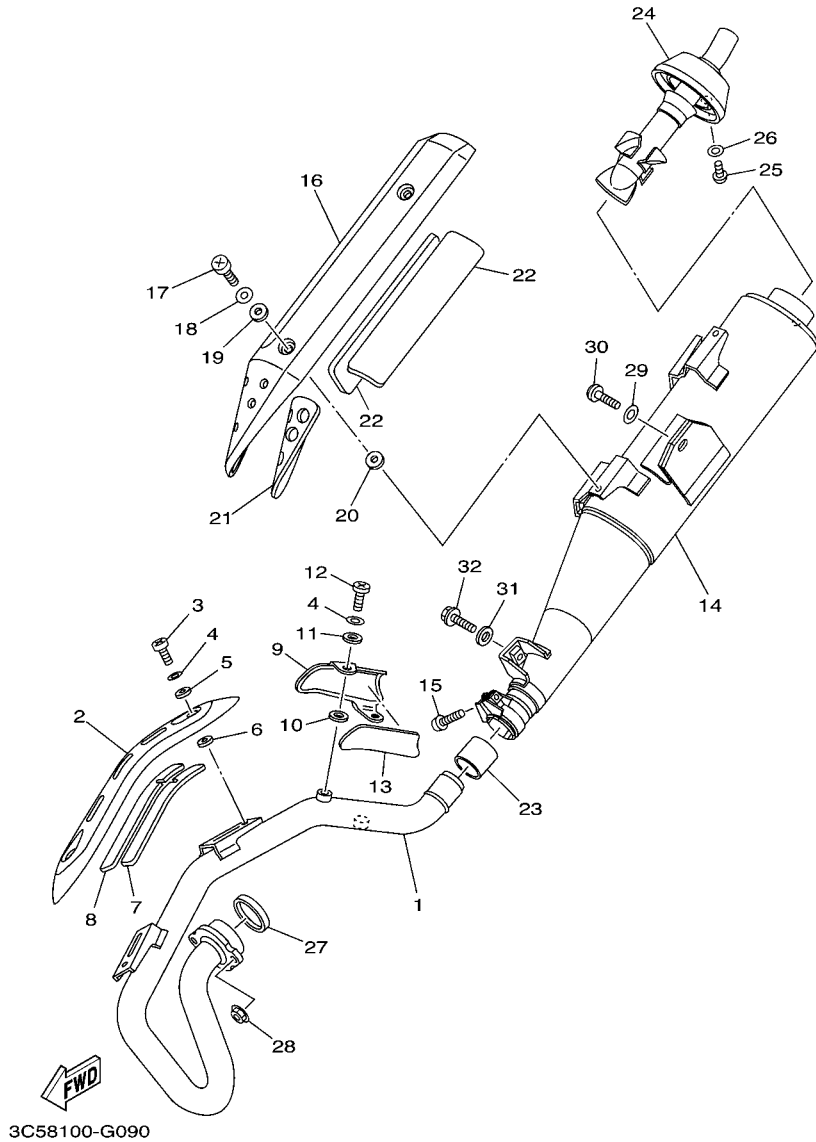

FIG. 9 EXHAUST

REF. NO.	PART NO.	DESCRIPTION	3C5F	3C5G	REMARKS
1	5XT-14611-10	PIPE, EXHAUST 1	1	1	
2	3C5-14628-00	PROTECTOR, EXHAUST PIPE	1	1	
3	98980-06012	SCREW, BIND	2	2	
4	90206-06090	WASHER, WAVE	4	4	
5	90201-05015	WASHER, PLATE	2	2	
6	90201-05016	WASHER, PLATE	2	2	
7	5XT-1465R-00	PLATE, PROTECTOR	1	1	
8	5XT-1465T-00	PLATE, PROTECTOR	1	1	
9	5XT-1479K-00	COVER, 3	1	1	
10	90201-05017	WASHER, PLATE	2	2	
11	90201-05015	WASHER, PLATE	2	2	
12	90154-06020	SCREW, BINDING	2	2	
13	5XT-1465U-00	PLATE, PROTECTOR 3	1	1	
14	3C5-14711-10	MUFFLER 1	1		
	3C5-14711-20	MUFFLER 1		1	
15	90109-085G6	BOLT	1	1	
16	3C5-14728-00	PROTECTOR, MUFFLER 2	1	1	
17	98980-06012	SCREW, BIND	4	4	
18	90206-06090	WASHER, WAVE	4	4	
19	90202-05187	WASHER, PLATE	4	4	
20	90202-05188	WASHER, PLATE	4	4	
21	5XT-14738-00	PROTECTOR, MUFFLER 3	1	1	
22	5XT-14748-00	PROTECTOR, MUFFLER 4	2	2	
23	3YF-14714-00	GASKET, MUFFLER	1	1	
24	1RH-14752-01	PIPE, OUTLET	1		
25	98507-06010	SCREW, PAN HEAD	1		
26	92907-06600	WASHER, PLATE	1		

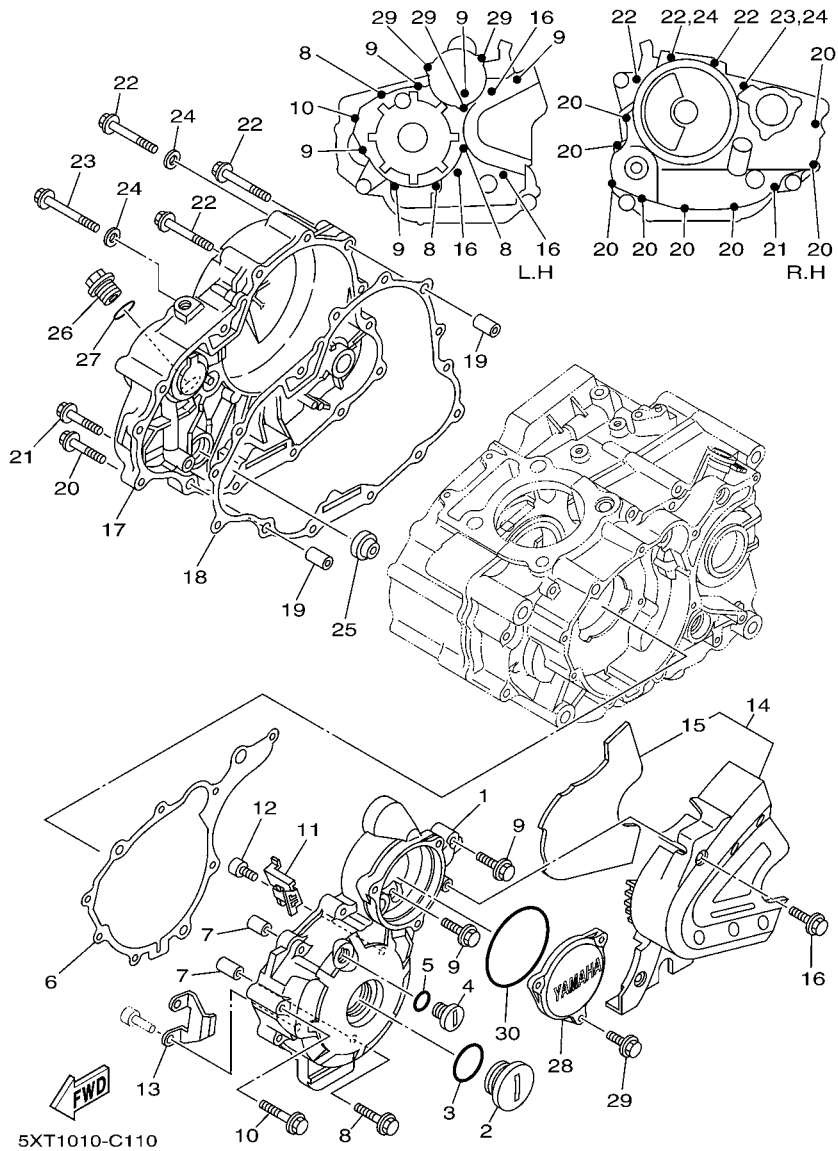

FIG. 11 CRANKCASE COVER 1

REF. NO.	PART NO.	DESCRIPTION	3C5F	3C5G	REMARKS
1	5XT-15411-02	COVER, CRANKCASE 1	1	1	
2	90340-32116	PLUG, STRAIGHT SCREW	1	1	
3	93210-32172	O-RING	1	1	
4	90340-14151	PLUG, STRAIGHT SCREW	1	1	
5	93210-14369	O-RING	1	1	
6	5XT-15451-00	GASKET, CRANKCASE COVER 1	1	1	
7	99530-10114	PIN, DOWEL	2	2	
8	95024-06040	BOLT, FLANGE	3	3	
9	95024-06030	BOLT, FLANGE	5	5	
10	95024-06045	BOLT, FLANGE	1	1	
11	90465-16011	CLAMP	1	1	
12	90110-05032	BOLT, HEXAGON SOCKET HEAD	1	1	
13	5XT-15113-00	PLATE	1	1	
14	5XT-15430-00	CRANKCASE COVER ASSY 3	1	1	
15	5XT-15316-00	.DAMPER 1	1	1	
16	95024-06016	BOLT, FLANGE	3	3	
17	5XT-15421-01	COVER, CRANKCASE 2	1	1	
18	5XT-15461-00	GASKET, CRANKCASE COVER 2	1	1	
19	99530-10114	PIN, DOWEL	2	2	
20	95024-06025	BOLT, FLANGE	8	8	
21	95024-06035	BOLT, FLANGE	1	1	
22	95024-06050	BOLT, FLANGE	3	3	
23	95024-06055	BOLT, FLANGE	1	1	
24	90430-06014	GASKET	2	2	
25	3Y1-15361-00	GAUGE, LEVEL	1	1	
26	90340-20002	PLUG, STRAIGHT SCREW	1	1	
27	93210-19123	O-RING	1	1	

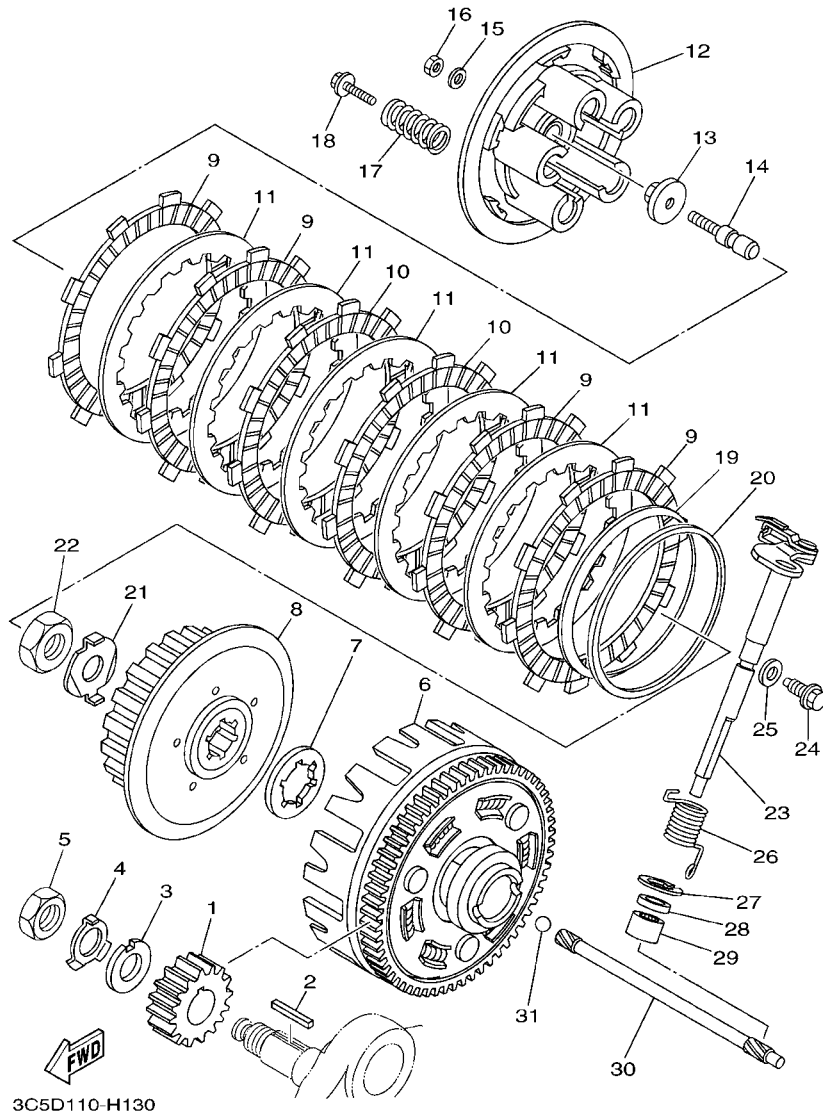
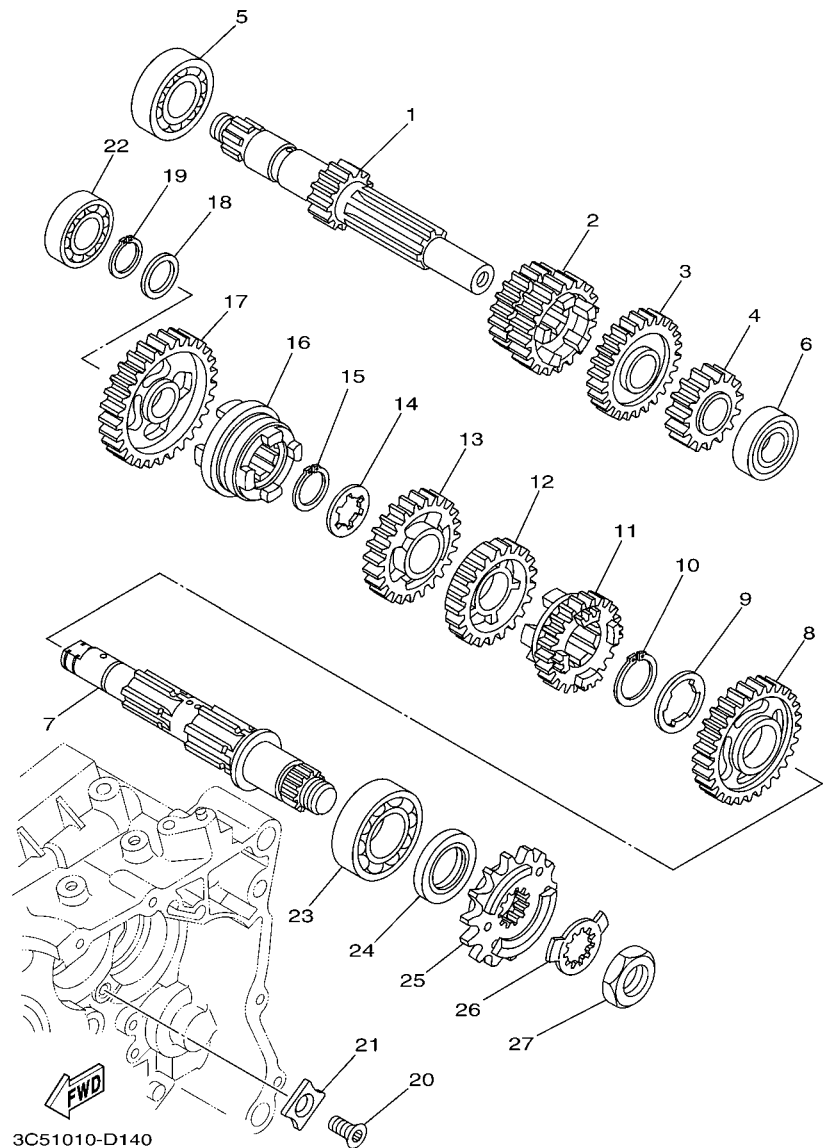

FIG. 13 CLUTCH

REF. NO.	PART NO.	DESCRIPTION	3C5F	3C5G	REMARKS
1	5XT-16111-00	GEAR, PRIMARY DRIVE (24T)	1	1	
2	90282-05077	KEY, STRAIGHT	1	1	
3	90214-16063	WASHER, CLAW	1	1	
4	90215-16293	WASHER, LOCK	1	1	
5	90170-16425	NUT	1	1	
6	5XT-16150-00	PRIMARY DRIVEN GEAR COMP.(74T)	1	1	
7	30X-16154-00	PLATE, THRUST 1	1	1	
8	4GY-16371-01	BOSS, CLUTCH	1	1	
9	1KT-16321-00	PLATE, FRICTION	4	4	
10	5DH-16321-00	PLATE, FRICTION	2	2	
11	3XJ-16324-01	PLATE, CLUTCH 1	5	5	
12	4GY-16351-00	PLATE, PRESSURE 1	1	1	
13	1W1-16358-01	PLATE, PUSH	1	1	
14	5XT-16356-00	ROD, PUSH 1	1	1	
15	92902-06200	WASHER	1	1	
16	95302-06600	NUT	1	1	
17	90501-23598	SPRING, COMPRESSION	5	5	
18	90159-06010	SCREW, WITH WASHER	5	5	
19	3XV-16383-00	SPRING, CLUTCH BOSS	1	1	
20	5NL-16384-00	PLATE, SEAT	1	1	
21	90215-16289	WASHER, LOCK	1	1	
22	90170-16326	NUT	1	1	
23	5XT-16380-00	PUSH LEVER ASSY	1	1	
24	90109-08105	BOLT	1	1	
25	90430-08119	GASKET	1	1	
26	90508-203B3	SPRING, TORSION	1	1	
27	99009-20500	CIRCLIP	1	1	

FIG. 14 TRANSMISSION



REF. NO.	PART NO.	DESCRIPTION	3C5F	3C5G	REMARKS
1	5XT-17411-00	AXLE, MAIN (13T)	1	1	
2	5XT-17131-00	GEAR, 3RD PINION (22T/28T)	1	1	
3	5XT-17151-10	GEAR, 5TH PINION (28T)	1	1	
4	51Y-17121-00	GEAR, 2ND PINION (16T)	1	1	
5	93306-20427	BEARING	1	1	
6	93306-00320	BEARING	1	1	
7	3C5-17402-00	DRIVE AXLE ASSY	1	1	
8	5XT-17221-00	GEAR, 2ND WHEEL (29T)	1	1	
9	90209-23241	WASHER	1	1	
10	93410-26067	CIRCLIP	1	1	
11	5XT-17251-10	GEAR, 5TH WHEEL (23T)	1	1	
12	5XT-17241-00	GEAR, 4TH WHEEL (29T)	1	1	
13	5XT-17231-00	GEAR, 3RD WHEEL (29T)	1	1	
14	90209-18208	WASHER	1	1	
15	93410-22039	CIRCLIP	1	1	
16	5BP-17285-00	CLUTCH, DOG	1	1	
17	3C5-17211-00	GEAR, 1ST WHEEL (37T)	1	1	
18	90201-177G4	WASHER, PLATE	1	1	
19	93410-17037	CIRCLIP	1	1	
20	90151-06008	SCREW, COUNTERSUNK	1	1	
21	3C5-17558-00	PLATE, BEARING	1	1	
22	93306-20332	BEARING	1	1	
23	93306-20532	BEARING	1	1	
24	93102-25226	OIL SEAL	1	1	
25	5XT-17460-00	SPROCKET, DRIVE (15T)	1	1	
26	90215-23265	WASHER, LOCK	1	1	
27	90179-18552	NUT	1	1	

FIG. 16 SHIFT SHAFT

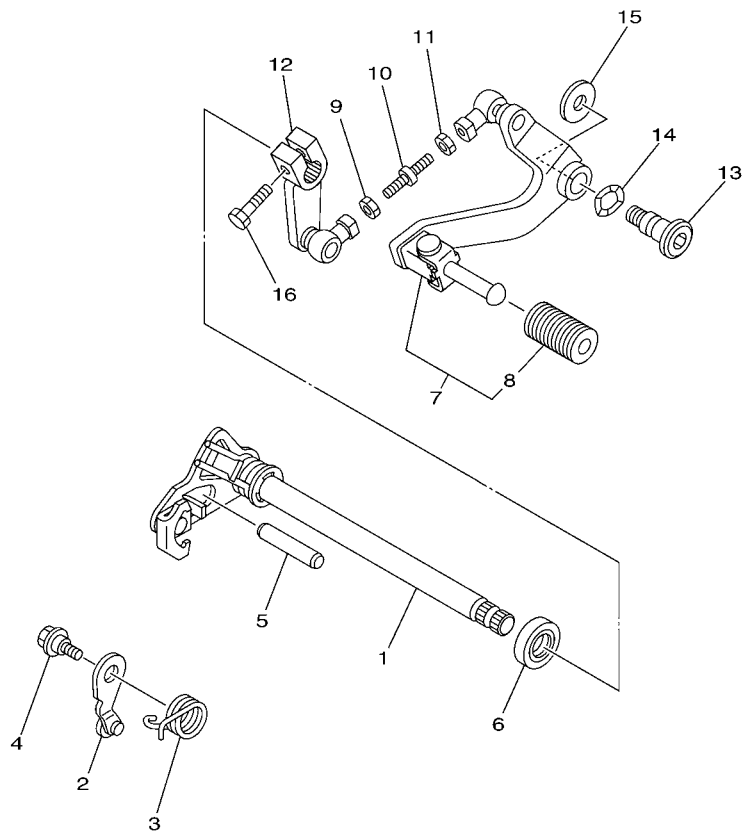

5XT2010-D160

REF. NO.	PART NO.	DESCRIPTION	3C5F	3C5G	REMARKS
1	5XT-18101-01	SHIFT SHAFT ASSY	1	1	
2	4TP-18140-00	STOPPER LEVER ASSY	1	1	
3	90508-26020	SPRING, TORSION	1	1	
4	90109-06189	BOLT	1	1	
5	93608-43228	PIN, DOWEL	1	1	
6	93102-14209	OIL SEAL	1	1	
7	5XT-18110-10	SHIFT PEDAL ASSY	1	1	
8	1W6-18113-00	.COVER, SHIFT PEDAL	1	1	
9	95317-06700	NUT	1	1	
10	5XT-18115-10	ROD, SHIFT	1	1	
11	90170-06022	NUT	1	1	
12	5XT-18112-10	ARM, SHIFT	1	1	
13	5XT-27434-00	BOLT	1	1	
14	90206-12074	WASHER, WAVE	1	1	
15	90201-08784	WASHER, PLATE	1	1	
16	97027-06020	BOLT, HEXAGON	1	1	

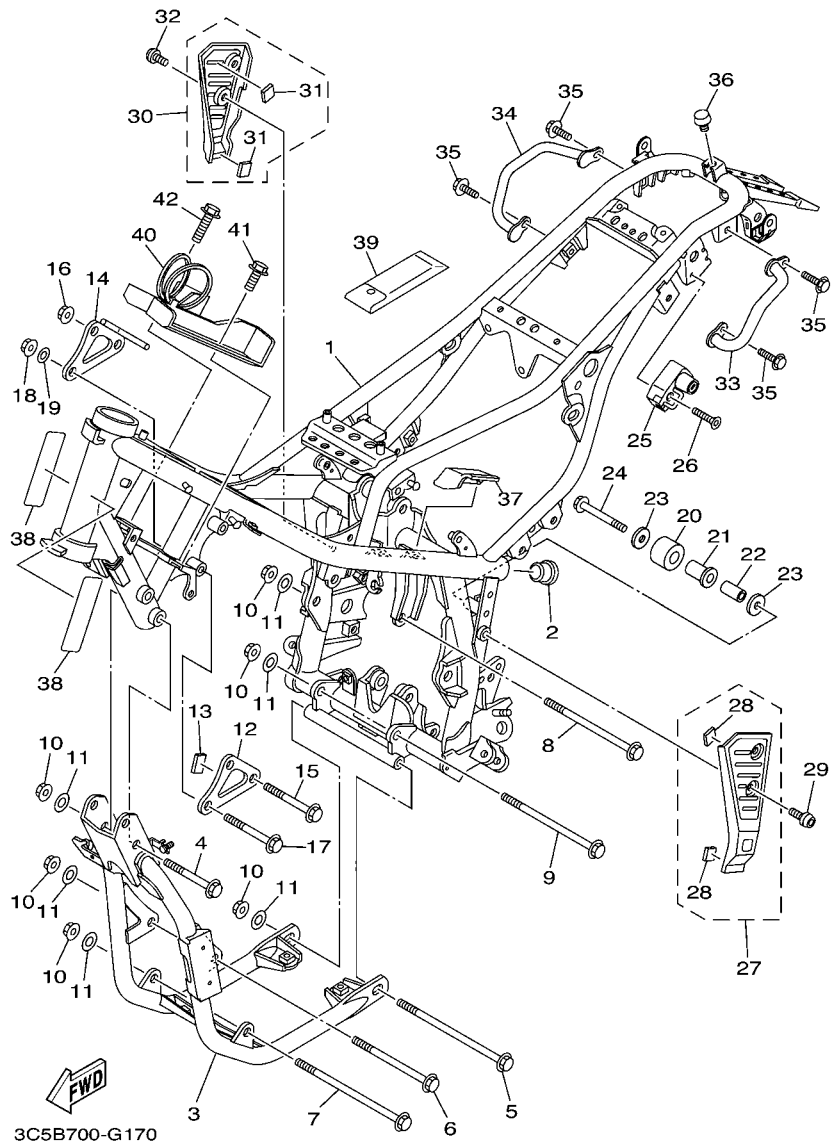

FIG. 17 FRAME

REF. NO.	PART NO.	DESCRIPTION	3C5F	3C5G	REMARKS
1	3C5-21110-30	FRAME COMP.	1	1	
2	90338-26004	PLUG	2	2	
3	3C5-21140-20	DOWN TUBE COMP.	1		
	3C5-21140-30	DOWN TUBE COMP.		1	
4	90105-10788	BOLT, FLANGE	2	2	
5	90105-10300	BOLT, FLANGE	1	1	
6	90105-10111	BOLT, FLANGE	1	1	
7	90105-10118	BOLT, FLANGE	1	1	
8	90105-10110	BOLT, FLANGE	1	1	
9	90105-10114	BOLT, FLANGE	1	1	
10	90179-10658	NUT	7	7	
11	90201-101J1	WASHER, PLATE	7	7	
12	3C5-21315-00	STAY, ENGINE 2	1	1	
13	51Y-21639-00	DAMPER 2	1	1	
14	3C5-21316-00	STAY, ENGINE 3	1	1	
15	90105-10116	BOLT, FLANGE	1	1	
16	90179-10658	NUT	1	1	
17	90105-08102	BOLT, FLANGE	2	2	
18	90179-08674	NUT	2	2	
19	90201-086P8	WASHER, PLATE	2	2	
20	10V-22178-00	TENSIONER	1	1	
21	10V-22184-00	BUSH	1	1	
22	90387-08024	COLLAR	1	1	
23	90201-08753	WASHER, PLATE	2	2	
24	95027-08045	BOLT, FLANGE	1	1	
25	4R8-21308-01	HELMET HANGER ASSY	1	1	
26	90151-06018	SCREW, COUNTERSUNK	1	1	

FOR AUS,NZL

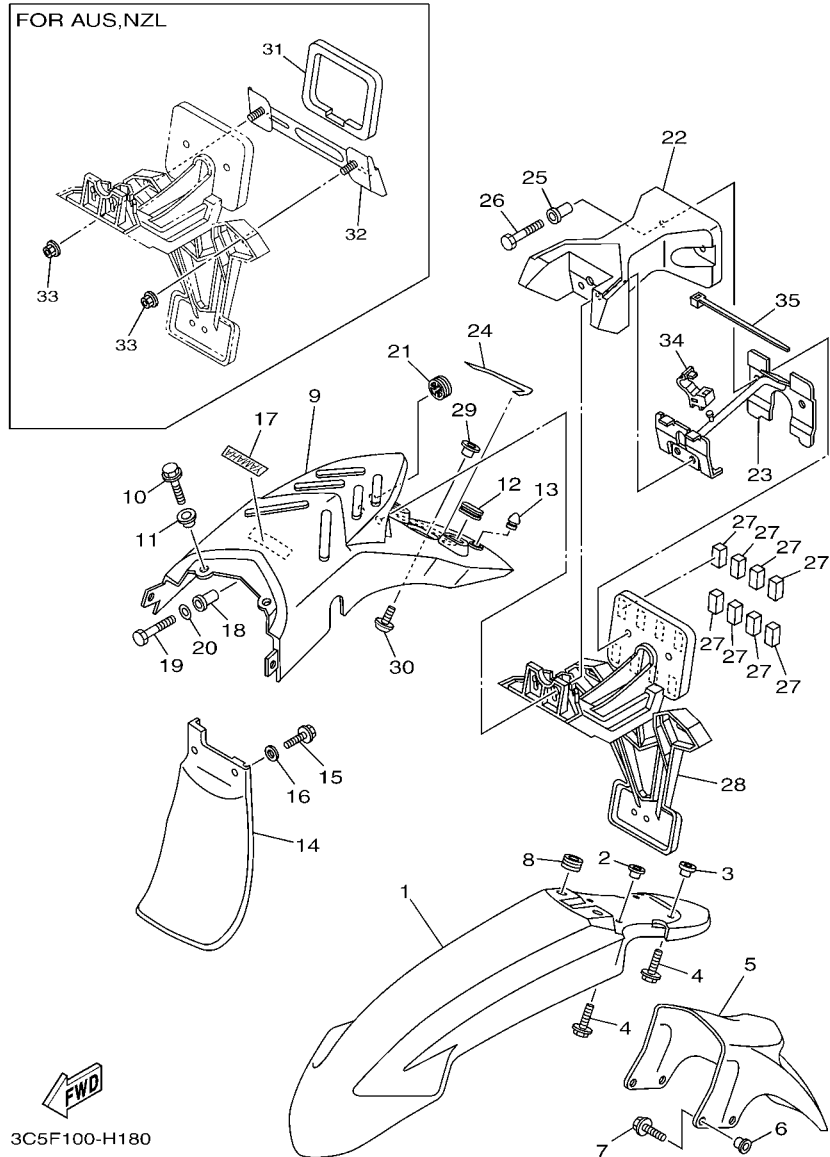

FIG. 18 FENDER

REF. NO.	PART NO.	DESCRIPTION	3C5F	3C5G	REMARKS
1	3C5-21511-10	FENDER, FRONT	1	1	
2	90387-06681	COLLAR	2	2	
3	90387-06117	COLLAR	2	2	
4	90119-06096	BOLT, WITH WASHER	4	4	
5	3C5-21556-00	FENDER, FRONT 2	1	1	
6	90387-06681	COLLAR	4	4	
7	90119-06096	BOLT, WITH WASHER	4	4	
8	90480-13398	GROMMET	2	2	
9	3C5-21611-20	FENDER, REAR	1	1	
10	95027-06012	BOLT, FLANGE	2	2	
11	90387-06107	COLLAR	2	2	
12	3C5-2163A-00	COVER, REAR FENDER 1	2	2	
13	4G0-21639-00	DAMPER 2	1	1	
14	5XT-21642-02	GUARD, FLAP	1	1	
15	95807-06016	BOLT, FLANGE	2	2	
16	90201-06055	WASHER, PLATE	2	2	
17	5XC-2153E-10	EMBLEM, YAMAHA	1	1	
18	90387-0602Y	COLLAR	2	2	
19	97007-06030	BOLT	2	2	
20	92907-06600	WASHER, PLATE	2	2	
21	4XV-83513-00	DAMPER	1	1	
22	3C5-84527-10	DAMPER	1	1	
23	3C5-2161A-00	BRACKET 3	1	1	
24	3C5-21652-00	PROTECTOR	1	1	
25	90387-06M21	COLLAR	2		
	90387-06M77	COLLAR		2	
26	97022-06030	BOLT	2		

FOR AUS,NZL

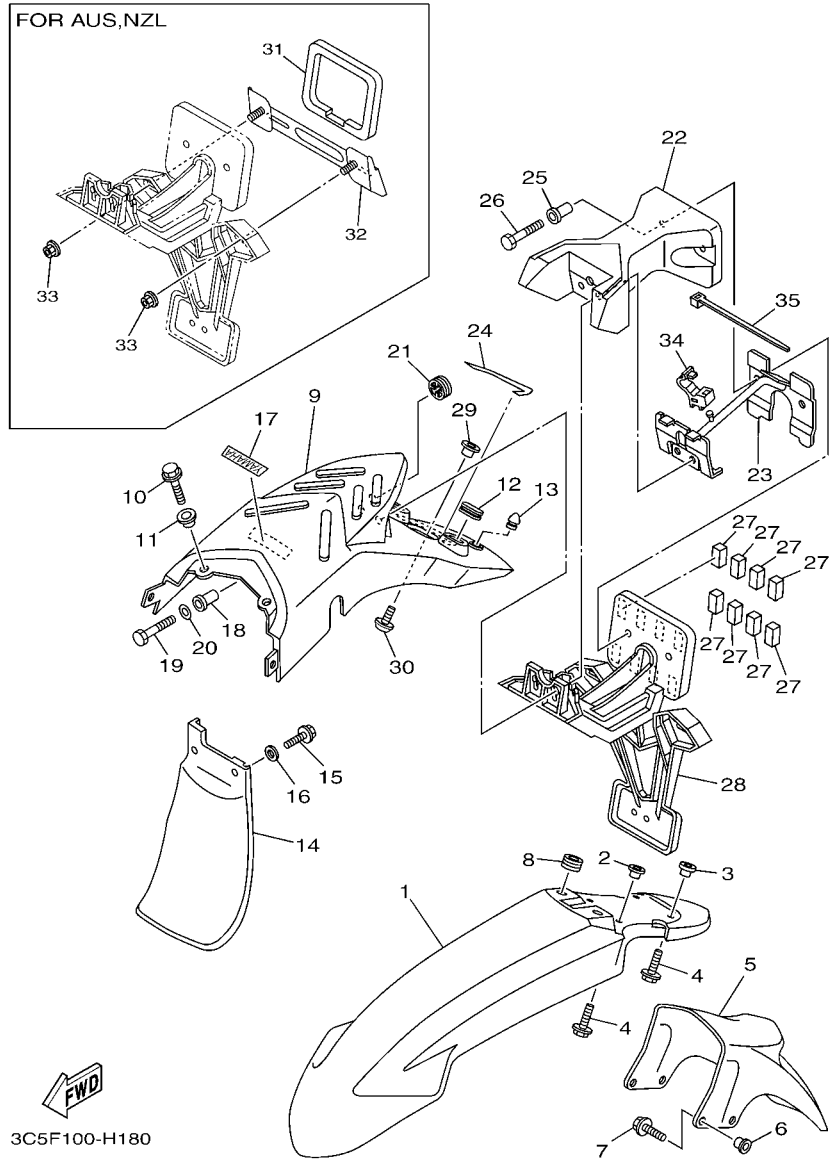

FIG. 18 FENDER

REF. NO.	PART NO.	DESCRIPTION	3C5F	3C5G	REMARKS
26	90101-06053	BOLT		2	
27	4D9-28415-00	DAMPER 1	8		
28	3C5-84551-00	BRACKET, LICENCE	1	1	
29	3C5-21634-00	COLLAR, 2	2	2	
30	90105-06170	BOLT, FLANGE	2	2	
31	4FD-84559-00	DAMPER		1	
32	4FD-21685-00	BRACKET, LICENSE		1	
33	95707-06500	NUT, FLANGE		2	
34	90464-05188	CLAMP	1	1	
35	5Y9-12491-00	CLAMP 1	1	1	

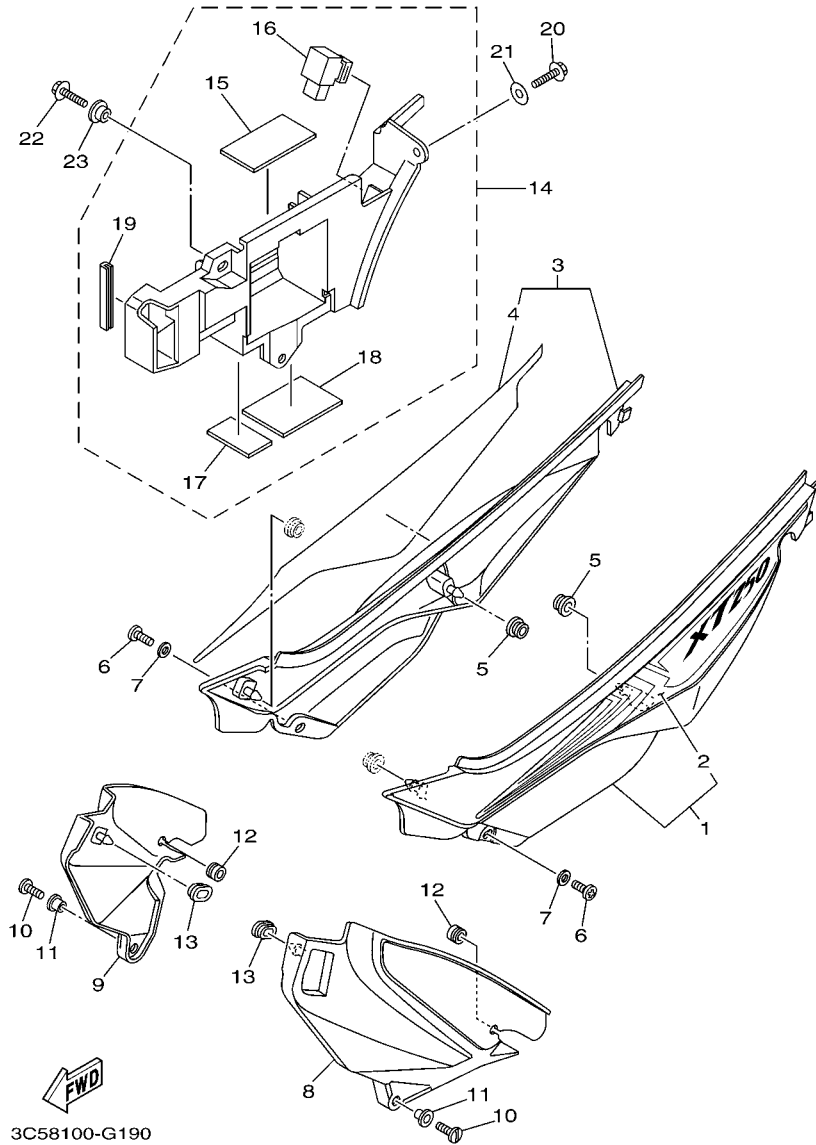

FIG. 19 SIDE COVER

REF. NO.	PART NO.	DESCRIPTION			REMARKS
			3C5F	3C5G	
1	3C5-Y2171-F0	COVER, SIDE 1	1	1	
2	3C5-2173E-B0	.GRAPHIC 1	1	1	
3	3C5-Y2172-F0	COVER, SIDE 2	1	1	
4	3C5-2173F-B0	.GRAPHIC 2	1	1	
5	90480-01558	GROMMET	2	2	
6	90149-06298	SCREW	2	2	
7	90201-06058	WASHER, PLATE	2	2	
8	3C5-21731-00	COVER, SIDE 3	1	1	
9	3C5-21741-00	COVER, SIDE 4	1	1	
10	90146-06014	SCREW, OVAL FILLISTER	2	2	
11	90387-06048	COLLAR	2	2	
12	90480-10334	GROMMET	2	2	
13	90480-01141	GROMMET	2	2	
14	3C5-8210E-00	BATTERY BOX ASSY	1	1	
15	5EJ-2414H-00	.DAMPER, PLATE 1	1	1	
16	4MY-83350-01	.FLASHER RELAY ASSY	1	1	
17	5XT-21732-00	.SEAL 1	1	1	
18	5XT-21735-00	.SEAL 2	1	1	
19	31A-24188-01	.MOLD, FUEL TANK	1	1	
20	90105-06057	BOLT, FLANGE	1	1	
21	90201-06063	WASHER, PLATE	1	1	
22	95807-06014	BOLT, FLANGE	2	2	
23	90387-06066	COLLAR	2	2	

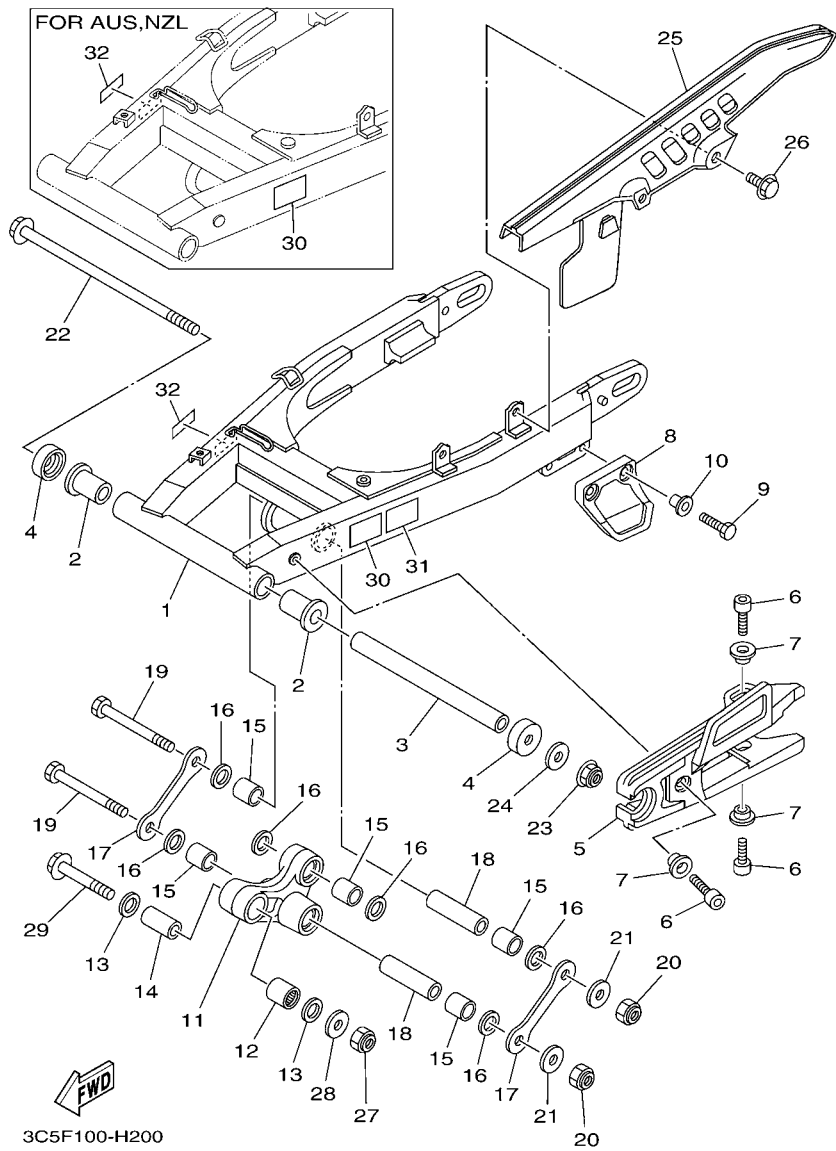
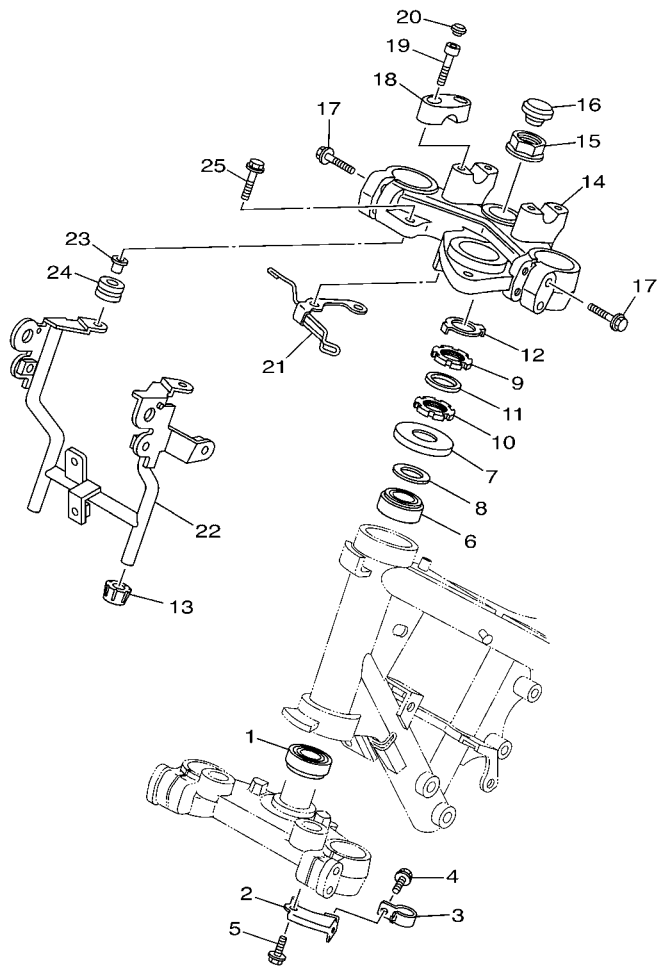

FIG. 20 REAR ARM

REF. NO.	PART NO.	DESCRIPTION	3C5F	3C5G	REMARKS
1	3C5-22110-00	REAR ARM COMP.	1	1	
2	90386-18099	BUSH	2	2	
3	5XT-22184-00	BUSH	1	1	
4	401-22128-01	COVER, THRUST 1	2	2	
5	3C5-22151-00	SEAL, GUARD	1	1	
6	91317-05014	BOLT	3	3	
7	5JG-22156-00	WASHER, PLATE	3	3	
8	5BT-22199-00	SUPPORT, CHAIN	1	1	
9	90119-06094	BOLT, WITH WASHER	2	2	
10	90387-06737	COLLAR	2	2	
11	5XT-2217A-00	ARM, RELAY	1	1	
12	93315-31750	BEARING	1	1	
13	93109-17071	OIL SEAL	2	2	
14	90387-126X9	COLLAR	1	1	
15	90383-17001	BUSH, FORMED	5	5	
16	93109-17071	OIL SEAL	6	6	
17	3C5-2217F-00	ROD, CONNECTING 1	2	2	
18	90387-123V9	COLLAR	2	2	
19	90101-12015	BOLT	2	2	
20	95617-12100	NUT, U	2	2	
21	90201-12699	WASHER, PLATE	2	2	
22	5JV-22141-00	SHAFT, PIVOT	1	1	
23	95604-12200	NUT, SELF-LOCKING	1	1	
24	90201-126A7	WASHER, PLATE	1	1	
25	34X-22311-00	CASE, CHAIN	1	1	
26	90119-05005	BOLT, WITH WASHER	2	2	
27	95617-12100	NUT, U	1	1	



3C58100-G220

FIG. 22 STEERING

REF. NO.	PART NO.	DESCRIPTION	3C5F	3C5G	REMARKS
1	93332-00079	BEARING	1	1	
2	3C5-25875-00	HOLDER, BRAKE HOSE 1	1	1	
3	3C5-25876-00	HOLDER, BRAKE HOSE 2	1	1	
4	95027-06010	BOLT, FLANGE	1	1	
5	95827-06012	BOLT, FLANGE	1	1	
6	93332-00079	BEARING	1	1	
7	1J7-23415-00	COVER, BALL RACE 1	1	1	
8	90201-256K5	WASHER, PLATE (0.5T)	1	1	
9	90179-25615	NUT	1	1	
10	90179-25033	NUT	1	1	
11	90202-26142	WASHER, PLATE	1	1	
12	3YF-23418-00	WASHER, SPECIAL	1	1	
13	3C5-23426-00	DAMPER	2	2	
14	3C5-23435-00	CROWN, HANDLE	1	1	
15	90179-22007	NUT	1	1	
16	5HP-2319U-00	CAP	1	1	
17	95024-08040	BOLT, FLANGE	4	4	
18	4H7-23441-01-P5	HOLDER, HANDLE UPPER	2	2	S8 FOR PWS1
19	91317-08030	BOLT	4	4	
20	90338-06004	PLUG	4	4	
21	3C5-2317E-01	STAY	1	1	
22	3C5-23348-10	HOLDER STOPPER 1	1	1	
23	90387-065G0	COLLAR	2	2	
24	90480-14011	GROMMET	2	2	
25	95027-06040	BOLT, FLANGE	2	2	

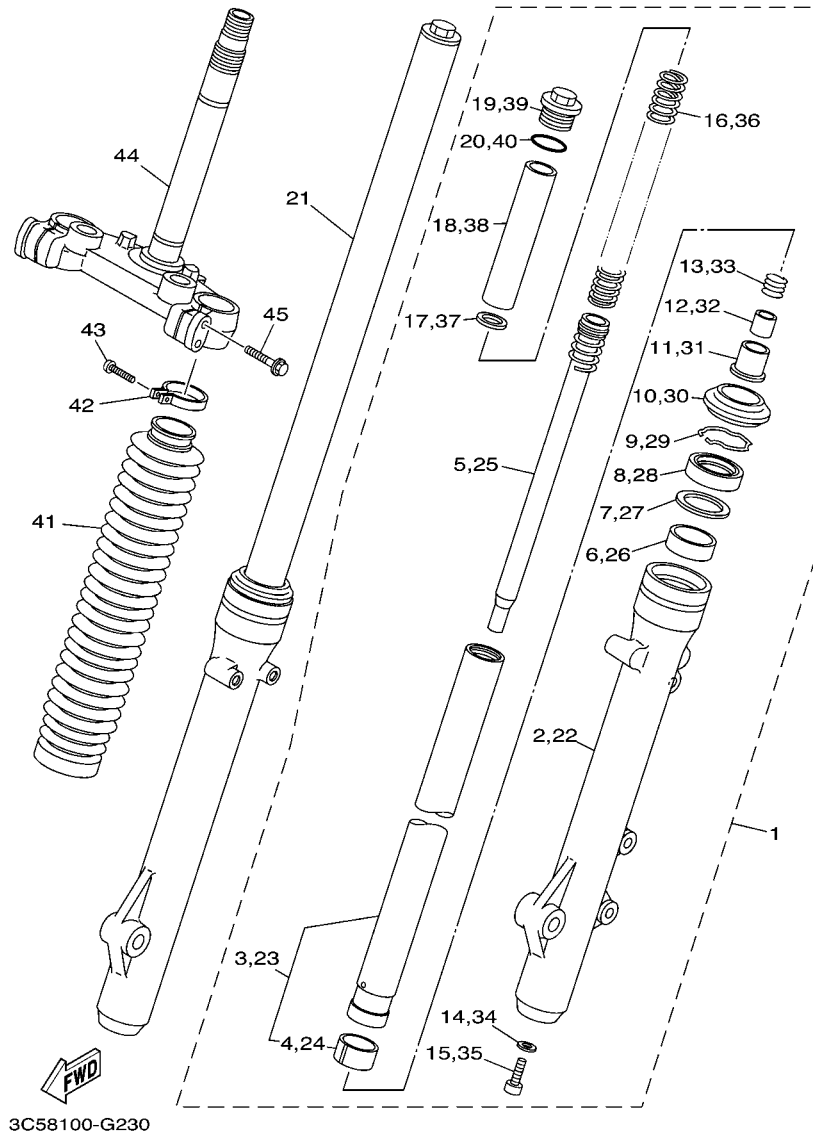
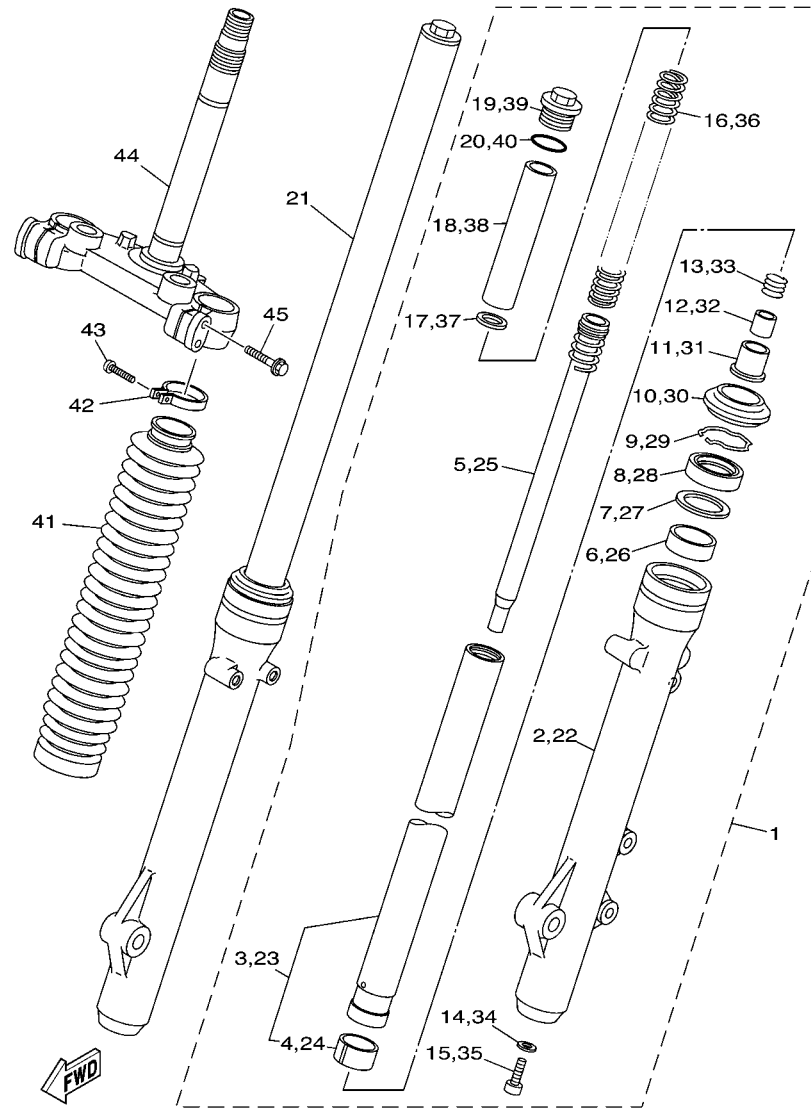

FIG. 23 FRONT FORK

REF. NO.	PART NO.	DESCRIPTION	3C5F	3C5G	REMARKS
1	3C5-23102-20	FRONT FORK ASSY (L.H)	1	1	
2	3C5-23126-10	.TUBE, OUTER (LEFT)	1	1	
3	3C5-23110-00	.INNER TUBE COMP.1	1	1	
4	5JX-23171-00	..PISTON, FRONT FORK	1	1	
5	3C5-23170-00	.CYLINDER COMP., FRONT FORK	1	1	
6	5JX-23125-00	.METAL, SLIDE 1	1	1	
7	5K5-23149-00	.WASHER, SPRING UPPER	1	1	
8	5JX-23145-00	.OIL SEAL	1	1	
9	4A1-23156-00	.RING, SNAP	1	1	
10	5JX-23144-00	.SEAL, DUST	1	1	
11	5XT-23173-00	.SPINDLE, TAPER	1	1	
12	5XT-23363-00	.COLLAR 1	1	1	
13	5XT-23151-00	.SPRING, REBOUND	1	1	
14	1N1-23158-00	.GASKET	1	1	
15	91311-08025	.BOLT	1	1	
16	3C5-23141-00	.SPRING, FRONT FORK	1	1	
17	4FY-23149-00	.WASHER, SPRING UPPER	1	1	
18	3C5-23118-00	.SPACER	1	1	
19	5JX-23111-00	.BOLT, CAP	1	1	
20	240-23114-00	.GASKET	1	1	
21	3C5-23103-20	FRONT FORK ASSY (R.H)	1	1	
22	3C5-23136-10	.TUBE, OUTER (RIGHT)	1	1	
23	3C5-23110-00	.INNER TUBE COMP.1	1	1	
24	5JX-23171-00	..PISTON, FRONT FORK	1	1	
25	3C5-23170-00	.CYLINDER COMP., FRONT FORK	1	1	
26	5JX-23125-00	.METAL, SLIDE 1	1	1	
27	5K5-23149-00	.WASHER, SPRING UPPER	1	1	



3C58100-G230

FIG. 23 FRONT FORK

REF. NO.	PART NO.	DESCRIPTION	3C5F	3C5G	REMARKS
28	5JX-23145-00	.OIL SEAL	1	1	
29	4A1-23156-00	.RING, SNAP	1	1	
30	5JX-23144-00	.SEAL, DUST	1	1	
31	5XT-23173-00	.SPINDLE, TAPER	1	1	
32	5XT-23363-00	.COLLAR 1	1	1	
33	5XT-23151-00	.SPRING, REBOUND	1	1	
34	1N1-23158-00	.GASKET	1	1	
35	91311-08025	.BOLT	1	1	
36	3C5-23141-00	.SPRING, FRONT FORK	1	1	
37	4FY-23149-00	.WASHER, SPRING UPPER	1	1	
38	3C5-23118-00	.SPACER	1	1	
39	5JX-23111-00	.BOLT, CAP	1	1	
40	240-23114-00	.GASKET	1	1	
41	3C5-23191-10	BOOT	2	2	
42	3C5-23192-00	BAND	2	2	
43	98506-04016	SCREW, PAN HEAD	2	2	
44	3C5-23340-10	UNDER BRACKET COMP.	1	1	
45	5RS-23346-00	BOLT 1	4	4	

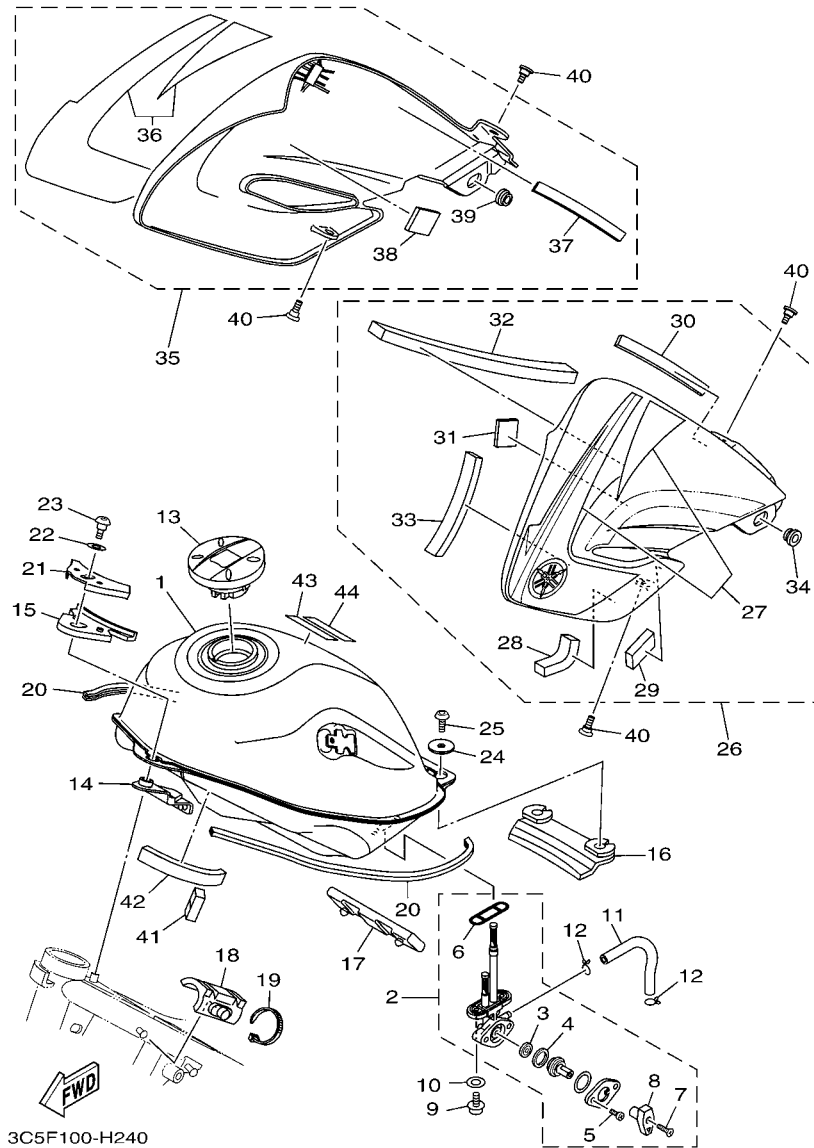

FIG. 24 FUEL TANK

REF. NO.	PART NO.	DESCRIPTION	3C5F	3C5G	REMARKS
1	3C5-24110-10-P0	FUEL TANK COMP.	1	1	MBL2 FOR PWS1
2	3C5-24500-00	FUEL COCK ASSY 1	1	1	
3	3C5-24523-00	.VALVE	1	1	
4	3AJ-24534-01	.SEAL, COCK	1	1	
5	98502-03008	.SCREW, PAN HEAD	2	2	
6	1P6-24512-00	.O-RING	1	1	
7	3D5-24535-00	.SCREW, LEVER FITTING	1	1	
8	3C5-24524-00	.LEVER, COCK	1	1	
9	90149-06108	SCREW	2	2	
10	90202-05193	WASHER, PLATE	2	2	
11	90445-10041	HOSE	1		
	90445-10007	HOSE (L110)		1	
12	90467-09006	CLIP	2	2	
13	5VK-24602-00	CAP ASSY	1	1	
14	3C5-24181-10	DAMPER, LOCATING 1	1	1	
15	3C5-24183-00	DAMPER, LOCATING 3	1	1	
16	3C5-24182-10	DAMPER, LOCATING 2	1	1	
17	3C5-24185-10	DAMPER, LOCATING 5	1	1	
18	3C5-24184-10	DAMPER, LOCATING 4	2	2	
19	1UA-82591-00	BAND	2	2	
20	3C5-24188-00	MOLD, FUEL TANK	2	2	
21	3C5-24186-00	WASHER, SPECIAL	1	1	
22	90202-10165	WASHER, PLATE	1	1	
23	90109-06084	BOLT	1	1	
24	90201-06074	WASHER, PLATE	2	2	
25	90149-06298	SCREW	2	2	
26	3C5-Y217W-F0	SCOOP COMP, AIR 1	1	1	

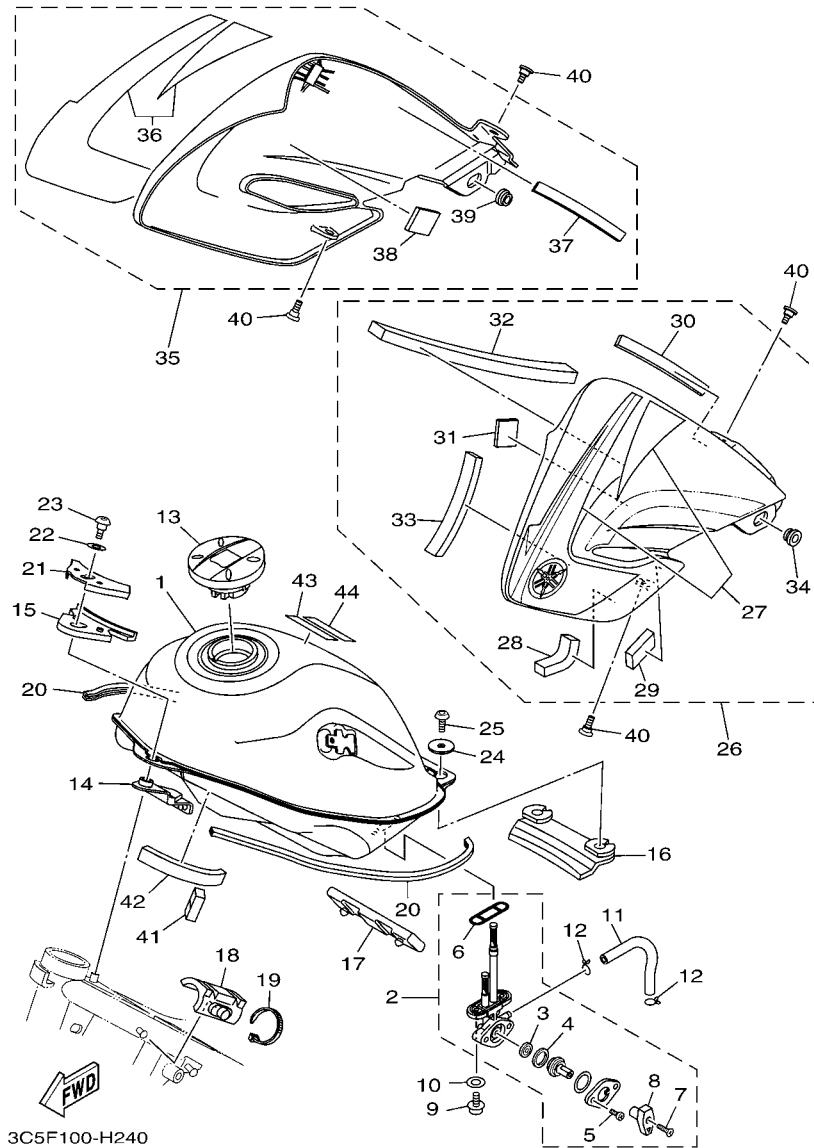
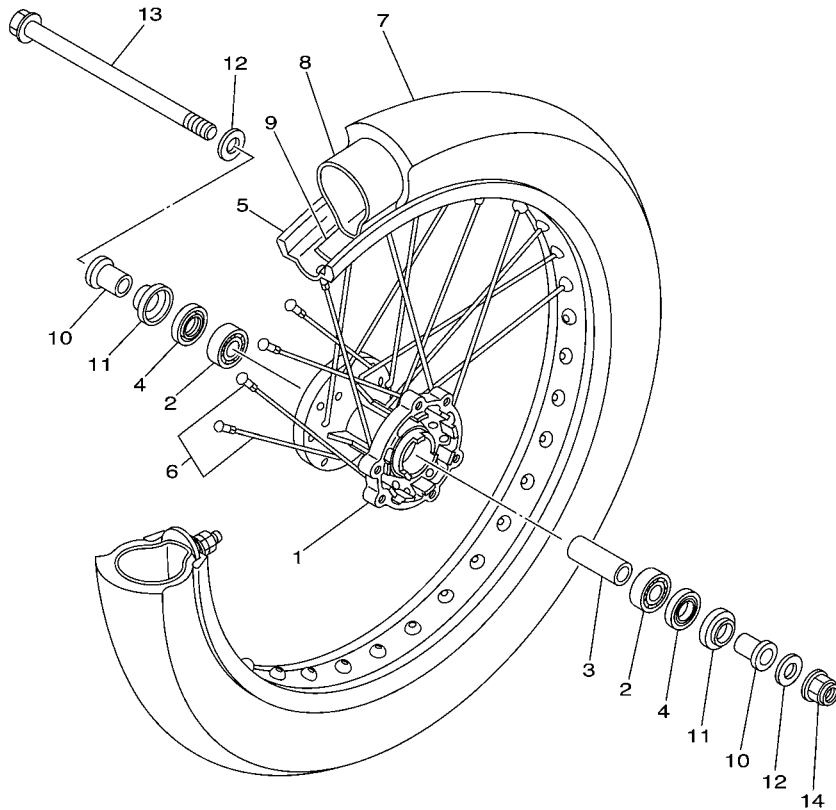

FIG. 24 FUEL TANK

REF. NO.	PART NO.	DESCRIPTION	3C5F	3C5G	REMARKS
27	3C5-2137C-B0	.GRAPHIC, SCOOP AIR SET 1	1	1	
28	3C5-24125-00	.SEAL, AIR SHROUD 1	1	1	
29	3C5-24126-00	.SEAL, AIR SHROUD 2	1	1	
30	3C5-2414H-00	.DAMPER, PLATE 1	1	1	
31	3C5-2414J-00	.DAMPER, PLATE 2	1	1	
32	3C5-2414K-00	.DAMPER, PLATE 3	1	1	
33	3C5-2414N-00	.DAMPER, PLATE 4	1	1	
34	90480-01559	.GROMMET	1	1	
35	3C5-Y217X-F0	SCOOP COMP., AIR 2	1	1	
36	3C5-2137D-B0	.GRAPHIC, SCOOP AIR SET 2	1	1	
37	3C5-2414H-00	.DAMPER, PLATE 1	1	1	
38	3C5-2414J-00	.DAMPER, PLATE 2	1	1	
39	90480-01559	.GROMMET	1	1	
40	90111-05011	BOLT,HEX. SOCKET BUTTON	4	4	
41	3C5-2414P-00	DAMPER, PLATE 5	1	1	
42	3C5-2416F-00	INSULATOR, FUEL TANK 1	1	1	
43	5GK-2118K-00	LABEL, CAUTION	1		
	5RU-21568-01	LABEL, WARNING		1	
44	5GK-2118K-10	LABEL, CAUTION	1		



3C58100-G260

FIG. 26 FRONT WHEEL

REF. NO.	PART NO.	DESCRIPTION	3C5F	3C5G	REMARKS
1	34X-25111-02-35	HUB, FRONT	1	1	SL FOR PWS1
2	93306-20205	BEARING	2	2	KOYO
3	90560-15290	SPACER	1	1	
4	93106-20021	OIL SEAL	2	2	
5	94416-21536	RIM (1.60-21)	1	1	
6	1KH-25104-00	SPOKE SET, FRONT	1	1	
7	94127-217Y3	TIRE (2.75-21 C6006 45P/TT)	1		CHENG SHIN
	94127-21008	TIRE(2.75-21 45P TW-301 G)		1	BRIDGESTONE
8	94227-21286	TUBE (275/3.00-21)	1		CHENG SHIN
	94227-21123	TUBE (MCS 2.75/3.00-21 TR6)		1	BRIDGESTONE
9	94327-21168	BAND, RIM (2.75-21)	1		
	94330-21084	BAND,RIM (1.60-21)		1	BRIDGESTONE
10	90387-15600	COLLAR	2	2	
11	322-25118-00	COVER, HUB DUST	2	2	
12	90201-15797	WASHER, PLATE	2	2	
13	5HH-25381-00	AXLE, WHEEL	1	1	
14	95607-14100	NUT, U	1	1	

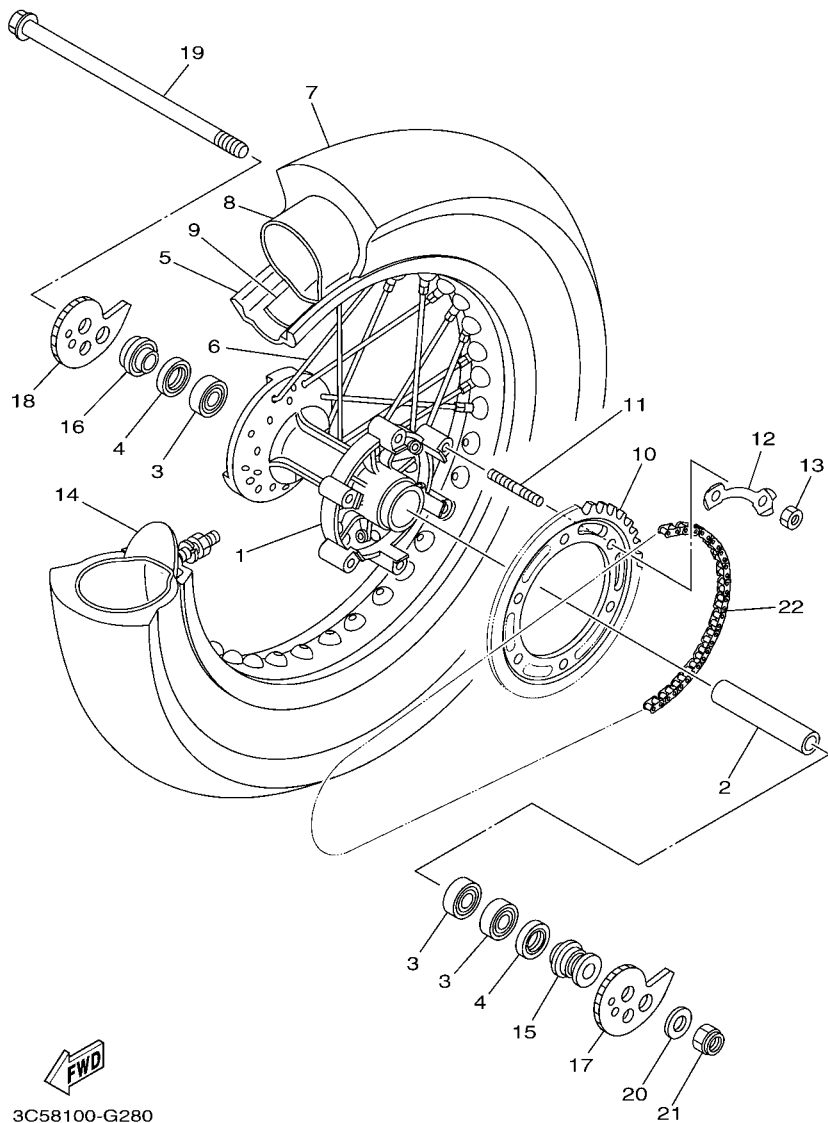

3C58100-G280

FIG. 28 REAR WHEEL

REF. NO.	PART NO.	DESCRIPTION	3C5F	3C5G	REMARKS
1	4JG-25311-02-35	HUB, REAR	1		SL FOR PWS1
2	90560-15313	SPACER	1		
3	93306-20212	BEARING	3		
4	93106-22032	OIL SEAL	2		
5	94421-18468	RIM (2.15-18)	1		
6	4JG-25304-00	SPOKE SET, REAR	1		
7	94112-187Y4	TIRE (120/80-18 M/C 62P TT)	1		CHENG SHIN
8	94232-18287	TUBE (3.25/350-18)	1		CHENG SHIN
9	94335-18167	BAND, RIM (3.50-18)	1		
10	3C5-25448-10	SPROCKET, DRIVEN (48T)	1		
11	90116-08218	BOLT, STUD	6		
12	4JG-25412-00	WASHER	3		
13	90170-08258	NUT	6		
14	3Y1-25394-00	SPACER, BEAD	1		
15	5XT-25383-00	COLLAR, WHEEL	1		
16	4JG-25383-00	COLLAR, WHEEL	1		
17	5XT-25388-00	PULLER, CHAIN 1	1		
18	5XT-25389-00	PULLER, CHAIN 2	1		
19	2K6-25381-10	AXLE, WHEEL	1		
20	90201-15014	WASHER, PLATE	2		
21	95607-14200	NUT, SELF-LOCKING	1		
22	94581-36128	CHAIN (DID428VS3)	1		

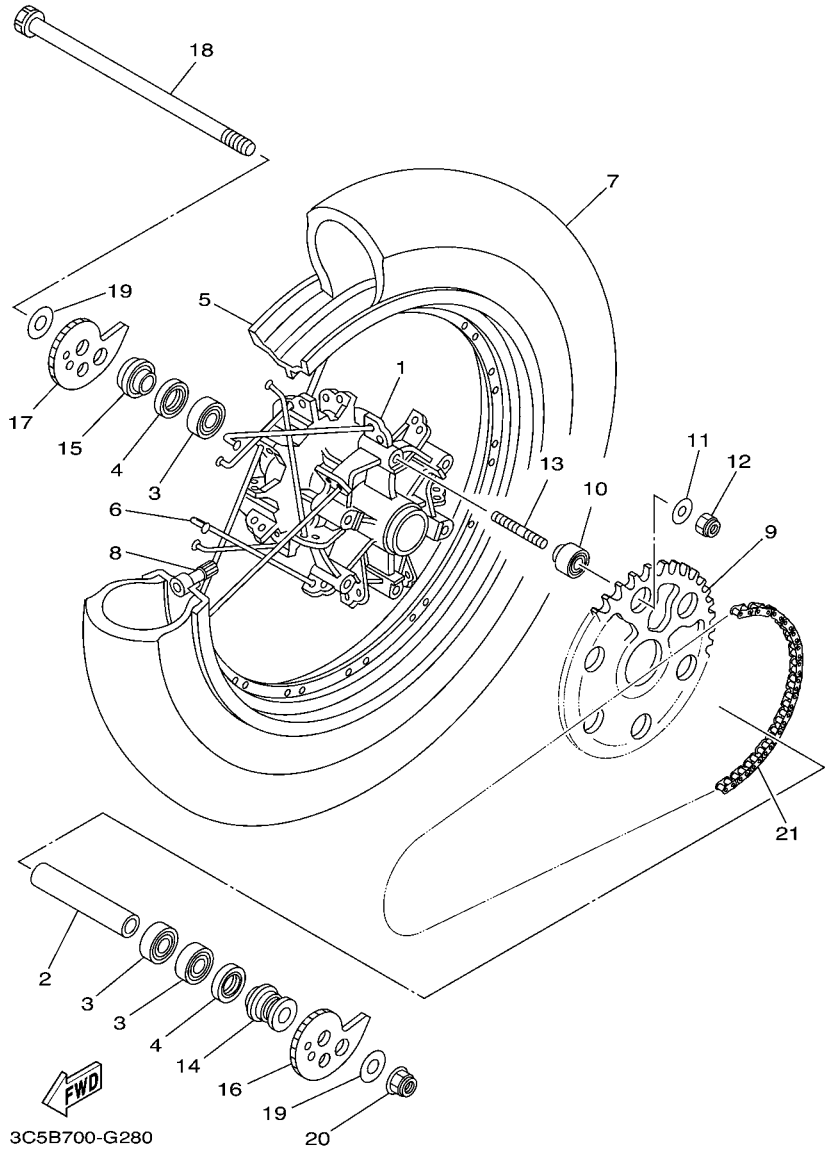
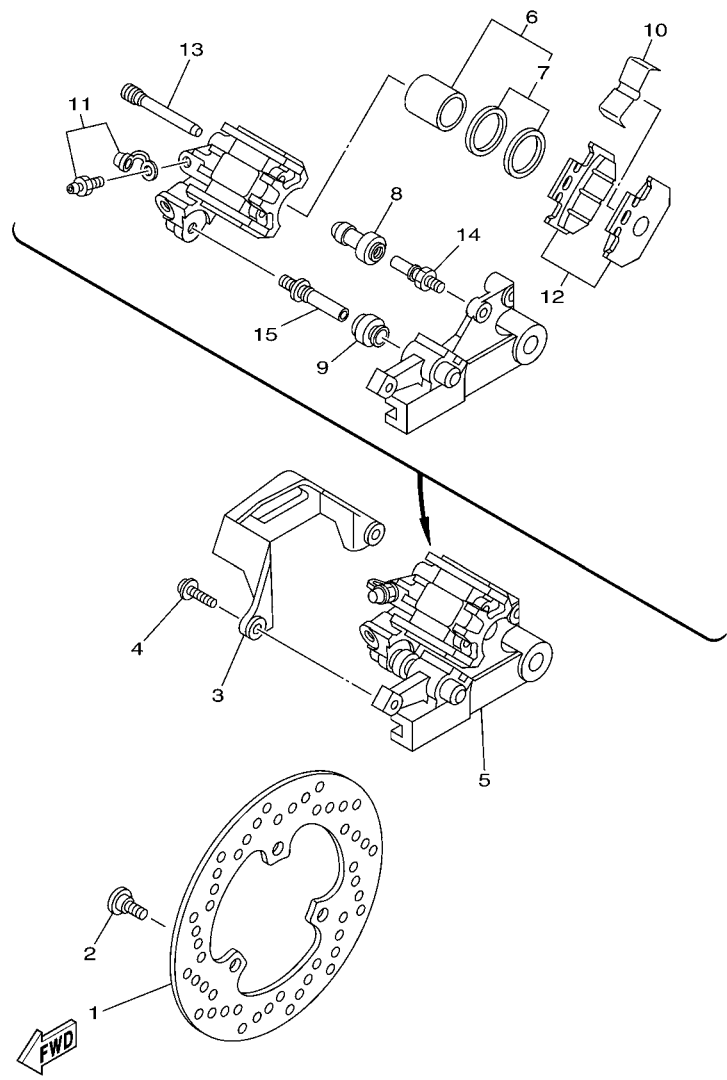

FIG. 29 REAR WHEEL 2

REF. NO.	PART NO.	DESCRIPTION	3C5F	3C5G	REMARKS
1	5MP-25311-00-35	HUB, REAR		1	SL FOR PWS1
2	90560-15313	SPACER		1	
3	93306-20212	BEARING		3	
4	93106-22032	OIL SEAL		2	
5	94421-18562	RIM (2.15-18)		1	
6	4JG-25304-10	SPOKE SET, REAR		1	
7	94112-18008	TIRE(120/80-18 62P TW-302 G)		1	BRIDGESTONE
8	93900-00022	VALVE, RIM (TR413)		1	TAIHEIYO
9	3C5-25448-00	SPROCKET, DRIVEN (48T)		1	
10	5XT-25364-00	DAMPER		6	
11	90201-08008	WASHER, PLATE		6	
12	95607-08100	NUT, U		6	
13	90116-08010	BOLT, STUD		6	
14	5XT-25383-00	COLLAR, WHEEL		1	
15	4JG-25383-00	COLLAR, WHEEL		1	
16	5XT-25388-00	PULLER, CHAIN 1		1	
17	5XT-25389-00	PULLER, CHAIN 2		1	
18	2K6-25381-10	AXLE, WHEEL		1	
19	90201-15014	WASHER, PLATE		2	
20	95607-14200	NUT, SELF-LOCKING		1	
21	94581-36128	CHAIN (DID428VS3)		1	



3C51010-D290

FIG. 30 REAR BRAKE CALIPER

REF. NO.	PART NO.	DESCRIPTION	3C5F	3C5G		REMARKS
1	5XT-2582W-00	DISK, REAR BRAKE 2	1	1		
2	90149-08268	SCREW	3	3		
3	4GY-27491-00	PROTECTOR	1	1		
4	92014-06016	BOLT, BUTTON HEAD	2	2		
5	3C5-2580W-01	CALIPER ASSY, REAR 2	1	1		
6	5XT-W0057-50	.PISTON ASSY, CALIPER	1	1		
7	3JD-W0047-51	..CALIPER SEAL KIT	1	1		
8	1UY-25937-51	.BOOT 2	1	1		
9	3JD-25917-00	.BOOT, CALIPER	1	1		
10	3SP-25919-51	.SUPPORT, PAD	1	1		
11	1UY-W0048-50	.BLEED SCREW KIT	1	1		
12	5XT-W0046-50	.BRAKE PAD KIT 2	1	1		
13	3SP-25924-51	.PIN, PAD	2	2		
14	3SP-25914-51	.PIN, SLIDE	1	1		
15	3SP-25926-51	.BOLT	1	1		

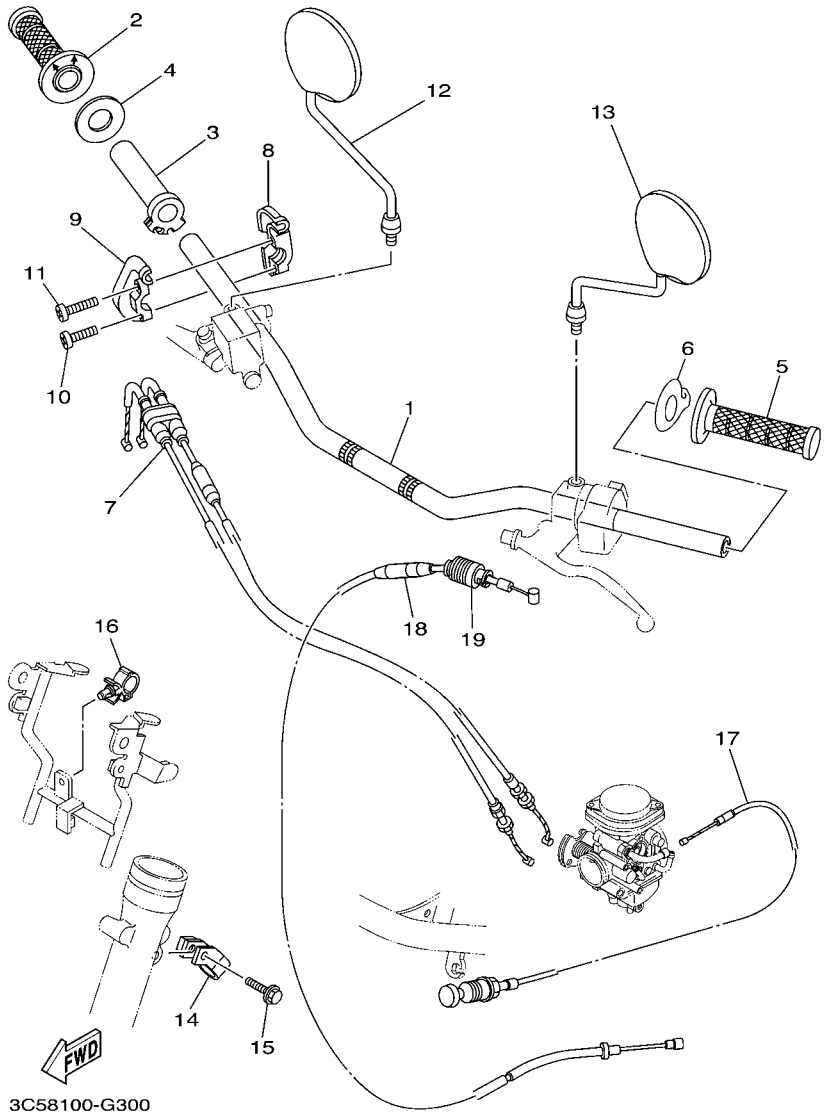
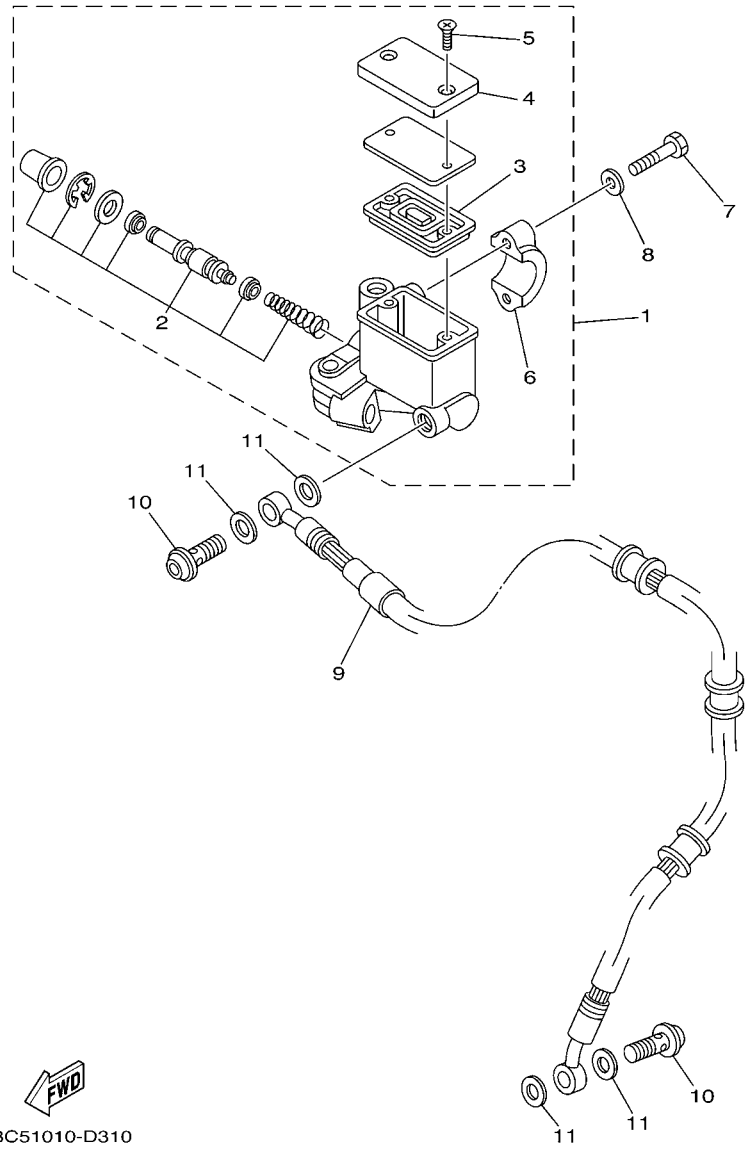

FIG. 31 STEERING HANDLE & CABLE

REF. NO.	PART NO.	DESCRIPTION	3C5F	3C5G	REMARKS
1	3C5-26111-00	HANDLEBAR	1	1	
2	4GY-26242-00	GRIP (RIGHT)	1	1	
3	5BE-26243-00	TUBE, THROTTLE GUIDE	1	1	
4	3Y1-26249-00	RING, LEAF	1	1	
5	4GY-26241-00	GRIP	1	1	
6	4RR-26129-00	WASHER	1	1	
7	3C5-26302-00	THROTTLE CABLE ASSY	1	1	
8	3LN-26281-01	CAP, GRIP UPPER	1	1	
9	3LN-26282-01	CAP, GRIP UNDER	1	1	
10	98507-05020	SCREW, PAN HEAD	1	1	
11	98507-05025	SCREW, PAN HEAD	1	1	
12	3Y1-26290-00	BACK MIRROR ASSY (R.H)	1		
	3C5-26290-00	REAR VIEW MIRROR ASSY (RIGHT)		1	
13	3Y1-26290-10	BACK MIRROR ASSY (L.H)	1		
	3C5-26280-00	REAR VIEW MIRROR ASSY (LEFT)		1	
14	3C5-25886-00	HOLDER, BRAKE HOSE	1	1	
15	95027-06025	BOLT, FLANGE	1	1	
16	90464-16012	CLAMP	1	1	
17	5XT-26331-01	CABLE, STARTER 1	1	1	
18	3C5-26335-00	CABLE, CLUTCH	1	1	
19	1E6-26342-00	BOOT, CABLE	1	1	



 3C51010-D310

FIG. 32 FRONT MASTER CYLINDER

REF. NO.	PART NO.	DESCRIPTION	3C5F	3C5G		REMARKS
1	5XT-2583T-00	MASTER CYLINDER ASSY	1	1		
2	5XT-W0041-00	.CYLINDER KIT, MASTER	1	1		
3	55U-25854-00	.GASKET, DIAPHRAGM	1	1		
4	3GM-25852-22	.CAP, RESERVOIR	1	1		
5	98706-04012	.SCREW, FLAT HEAD	2	2		
6	56A-25867-00	.HOLDER	1	1		
7	97007-06025	BOLT	2	2		
8	92907-06600	WASHER, PLATE	2	2		
9	3C5-25872-00	HOSE, BRAKE 1	1	1		
10	90401-10172	BOLT, UNION	2	2		
11	90430-10005	GASKET	4	4		

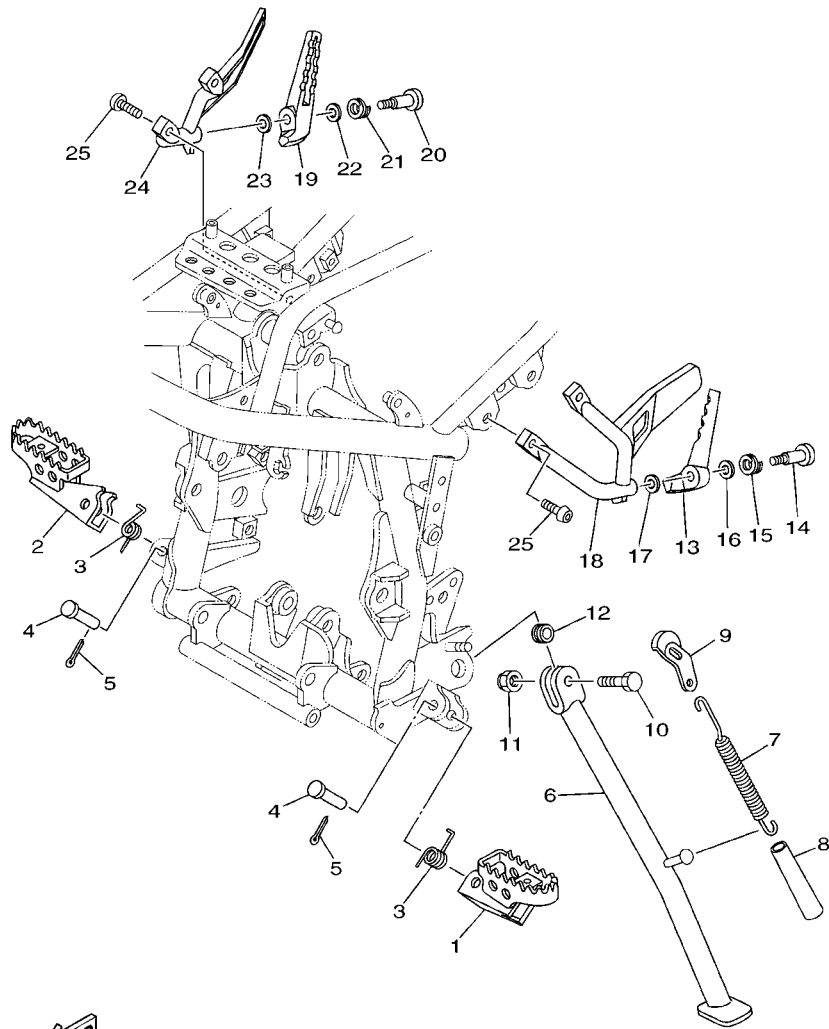

3C5D110-H320

FIG. 33 STAND & FOOTREST

REF. NO.	PART NO.	DESCRIPTION	3C5F	3C5G	REMARKS
1	3LD-27411-01	FOOTREST 1	1	1	
2	3LD-27421-01	FOOTREST 2	1	1	
3	90508-20583	SPRING, TORSION	2	2	
4	90240-10101	PIN, CLEVIS	2	2	
5	91401-25015	PIN, COTTER	2	2	
6	3C5-27311-10	STAND, SIDE	1	1	
7	90506-35473	SPRING, TENSION	1	1	
8	90445-22327	HOSE (L70)	1	1	
9	5XT-27315-01	LINK, SIDE STAND	1	1	
10	90101-10013	BOLT	1	1	
11	90185-10060	NUT, SELF-LOCKING	1	1	
12	90387-10003	COLLAR	1	1	
13	3XP-27431-02	FOOTREST, REAR 1	1	1	
14	90109-085F5	BOLT	1	1	
15	90504-18005	SPRING, COMPRESSION	1	1	
16	92907-10600	WASHER, PLATE	1	1	
17	90201-083P5	WASHER, PLATE	1	1	
18	3C5-27432-00	BRACKET 1	1	1	
19	3XP-27441-02	FOOTREST, REAR 2	1	1	
20	90109-085F5	BOLT	1	1	
21	90504-18005	SPRING, COMPRESSION	1	1	
22	92907-10600	WASHER, PLATE	1	1	
23	90201-083P5	WASHER, PLATE	1	1	
24	3C5-27442-00	BRACKET 2	1	1	
25	92012-08020	BOLT, BUTTON HEAD	4	4	

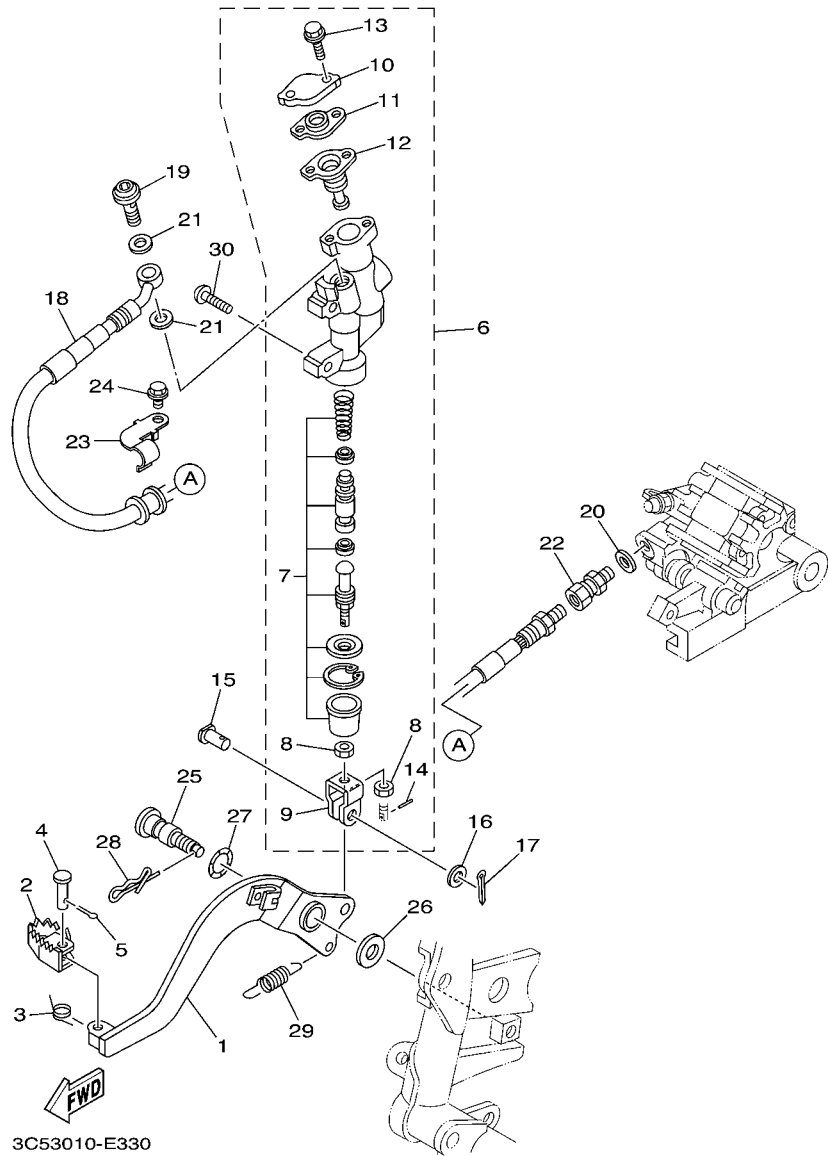

FIG. 34 REAR MASTER CYLINDER

REF. NO.	PART NO.	DESCRIPTION	3C5F	3C5G	REMARKS
1	3C5-27211-10	PEDAL, BRAKE	1	1	
2	55V-27242-00	PEDAL, BRAKE	1	1	
3	90508-14352	SPRING, TORSION	1	1	
4	91701-06022	PIN	1	1	
5	91401-20012	PIN, COTTER	1	1	
6	5XT-2583V-10	RR. MASTER CYLINDER ASSY.	1	1	
7	5XT-W0042-50	.CYLINDER KIT, MASTER	1	1	
8	4SS-27218-00	.NUT	2	2	
9	2YK-27222-00	.JOINT	1	1	
10	5UN-25852-50	.CAP, RESERVOIR	1	1	
11	5UN-2585B-00	.PLATE, DIAPHRAGM	1	1	
12	5UN-25854-00	.GASKET, DIAPHRAGM	1	1	
13	5UN-27217-00	.BOLT	2	2	
14	3KW-27234-00	.PIN, BRAKE ROD	1	1	
15	90240-08124	PIN, CLEVIS	1	1	
16	90201-08083	WASHER, PLATE	1	1	
17	91401-16012	PIN, COTTER	1	1	
18	3C5-25873-00	HOSE, BRAKE 2	1	1	
19	90401-10172	BOLT, UNION	1	1	
20	90201-10118	WASHER, PLATE	1	1	
21	90430-10005	GASKET	2	2	
22	3LC-25885-00	JOINT	1	1	
23	3C5-25887-00	HOLDER, BRAKE HOSE	1	1	
24	95807-06008	BOLT, FLANGE	1	1	
25	5XT-27261-00	SHAFT	1	1	
26	90201-10135	WASHER, PLATE	1	1	
27	90206-14001	WASHER, WAVE	1	1	

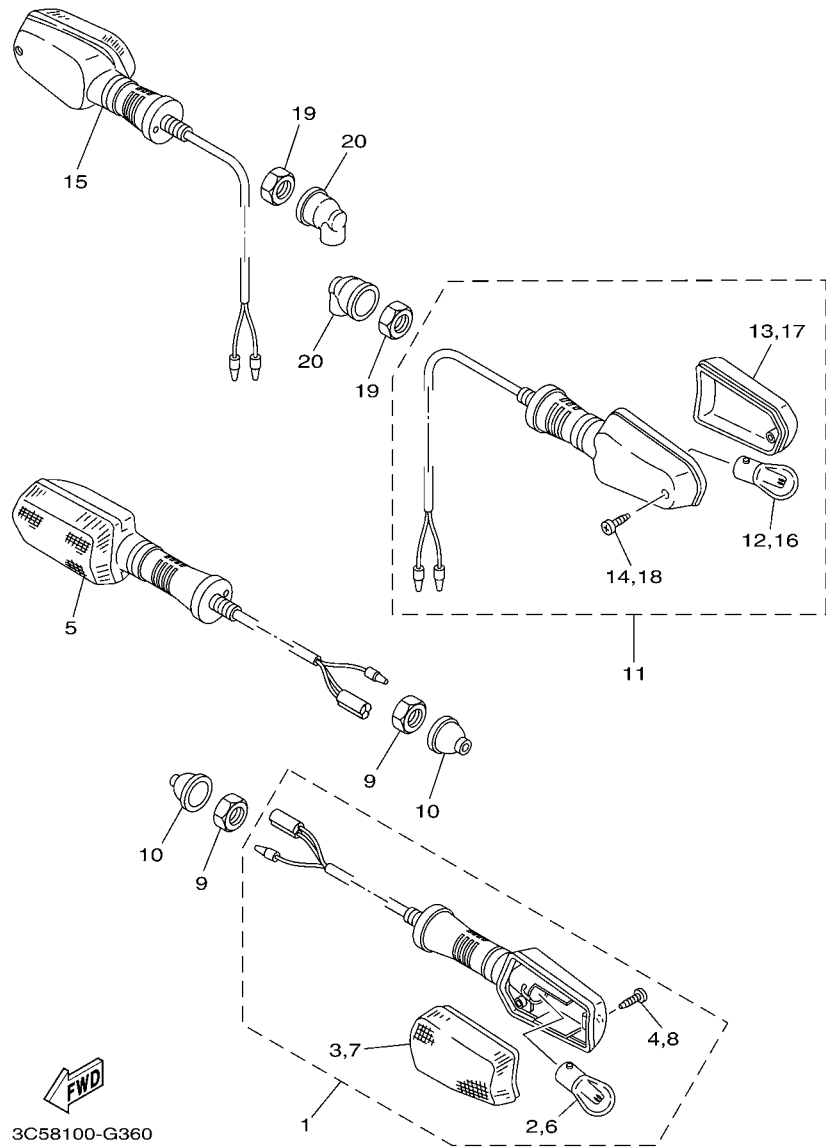

FIG. 37 FLASHER LIGHT

REF. NO.	PART NO.	DESCRIPTION	3C5F	3C5G		REMARKS
1	3C5-83310-10	FRONT FLASHER LIGHT ASSY 1	1			
2	256-84714-61	.BULB (12V-27/8W)	1			
3	1LJ-83342-00	.LENS, FLASHER 2	1			
4	97707-40520	.SCREW, TAPPING	1			
5	3C5-83320-10	FRONT FLASHER LIGHT ASSY 2	1			
6	256-84714-61	.BULB (12V-27/8W)	1			
7	1LJ-83332-00	.LENS, FLASHER	1			
8	97707-40520	.SCREW, TAPPING	1			
9	95307-12700	NUT	2			
10	10V-83365-00	CAP	2			
11	3C5-83330-10	REAR FLASHER LIGHT ASSY 1	1			
12	256-83311-70	.BULB (12V-27W)	1			
13	1LJ-83332-00	.LENS, FLASHER	1			
14	97707-40520	.SCREW, TAPPING	1			
15	4BE-83340-00	REAR FLASHER LIGHT ASSY 2	1			
16	256-83311-70	.BULB (12V-27W)	1			
17	1LJ-83342-00	.LENS, FLASHER 2	1			
18	97707-40520	.SCREW, TAPPING	1			
19	95307-12700	NUT	2			
20	18G-83365-00	CAP	2			

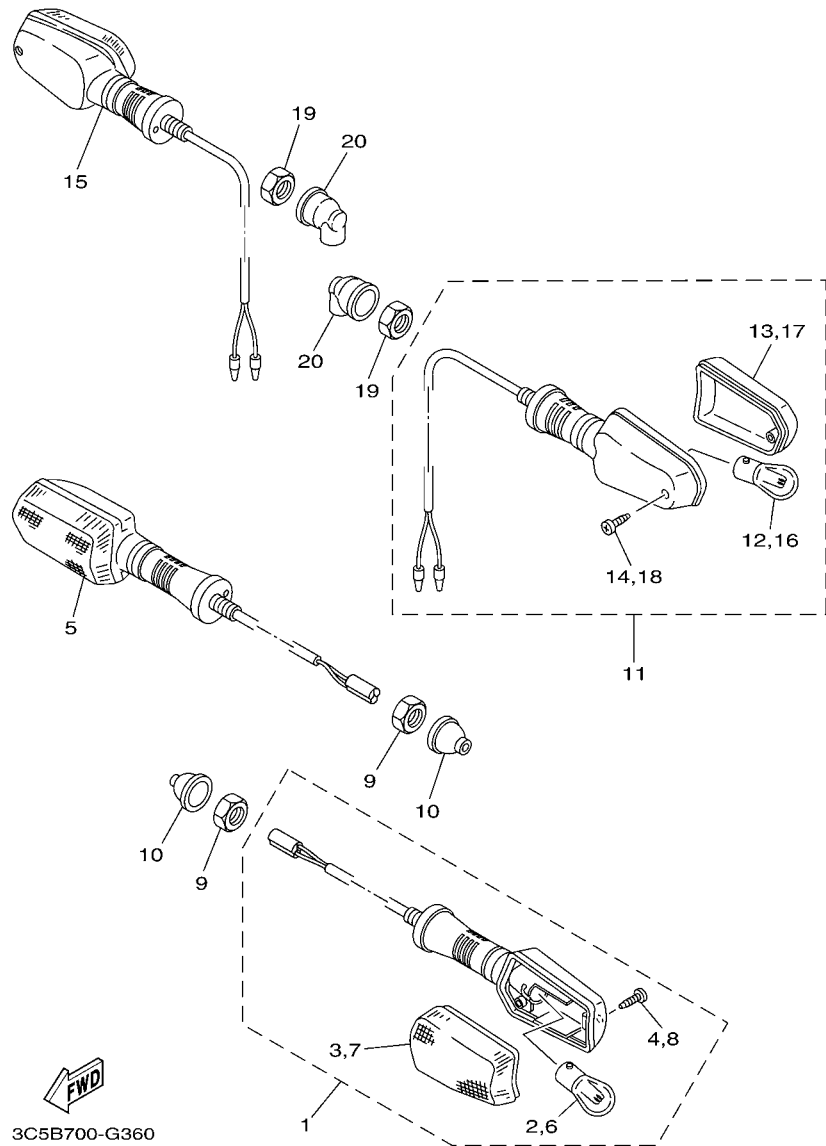
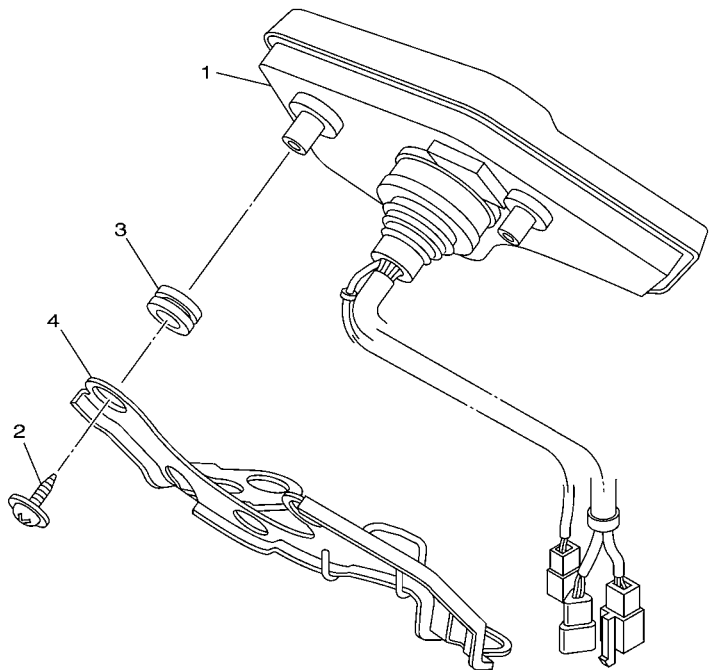

FIG. 38 FLASHER LIGHT 2

REF. NO.	PART NO.	DESCRIPTION	3C5F	3C5G	REMARKS
1	3C5-83310-20	FRONT FLASHER LIGHT ASSY 1		1	
2	306-83311-40	.BULB, FLASHER (12V-21W)		1	
3	51L-83332-01	.LENS, FLASHER		1	
4	97706-40620	.SCREW, TAPPING		1	
5	3C5-83320-20	FRONT FLASHER LIGHT ASSY 2		1	
6	306-83311-40	.BULB, FLASHER (12V-21W)		1	
7	51L-83342-01	.LENS, FLASHER 2		1	
8	97706-40620	.SCREW, TAPPING		1	
9	95307-12700	NUT		2	
10	10V-83365-00	CAP		2	
11	3C5-83330-20	REAR FLASHER LIGHT ASSY 1		1	
12	256-83311-70	.BULB (12V-27W)		1	
13	1LJ-83332-00	.LENS, FLASHER		1	
14	97707-40520	.SCREW, TAPPING		1	
15	4FD-83340-00	REAR FLASHER LIGHT ASSY 2		1	
16	306-83311-40	.BULB, FLASHER (12V-21W)		1	
17	1LJ-83342-00	.LENS, FLASHER 2		1	
18	97707-40520	.SCREW, TAPPING		1	
19	95307-12700	NUT		2	
20	18G-83365-00	CAP		2	

FIG. 39 METER



REF. NO.	PART NO.	DESCRIPTION	3C5F	3C5G				REMARKS
1	3C5-83500-00	METER ASSY	1					
	3C5-83500-20	METER ASSY		1				
2	90164-05014	SCREW, TAPPING	3	3				
3	90480-14555	GROMMET	3	3				
4	3C5-83519-00	BRACKET, METER	1	1				

3C51010-D370

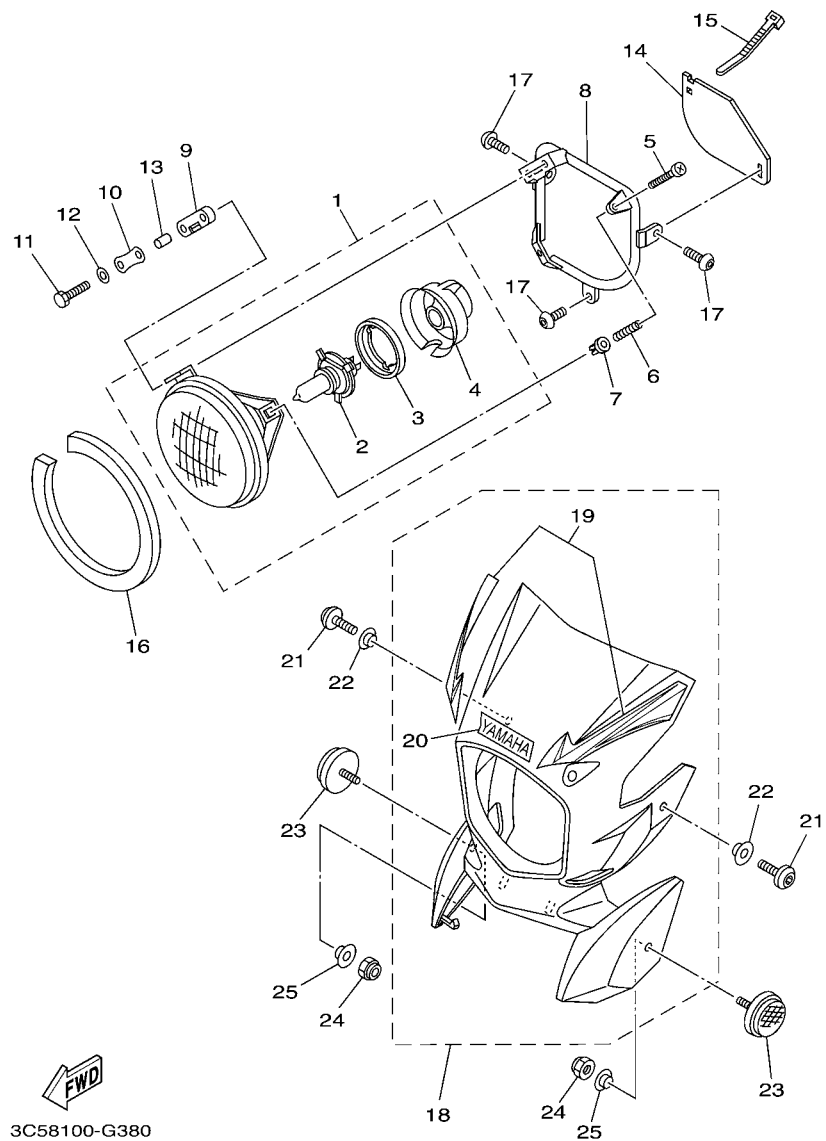

FIG. 40 HEADLIGHT

REF. NO.	PART NO.	DESCRIPTION	3C5F	3C5G	REMARKS
1	3C5-84320-00	LENS ASSY	1	1	
2	2F9-84314-00	.BULB (12V-60/55W)	1	1	(H4)HALOGEN
3	2F9-84375-00	.SETTING PLATE, BULB	1	1	
4	2F9-84397-01	.COVER, SOCKET	1	1	
5	2F9-84331-00	SCREW, RIM ADJUSTING	2	2	
6	341-84332-60	SPRING, SCREW	2	2	
7	4B4-84334-00	NUT, ADJUSTING	2	2	
8	3C5-84315-00	RIM, HEADLIGHT	1	1	
9	3C5-84366-00	DAMPER, HEADLIGHT 1	1	1	
10	3C5-84127-00	WASHER, SPECIAL	1	1	
11	97002-05020	BOLT	2	2	
12	92902-05600	WASHER, PLATE	2	2	
13	90387-05383	COLLAR	2	2	
14	3C5-84144-00	COVER, HEADLIGHT	1	1	
15	90465-10098	CLAMP	1	1	
16	3C5-84559-00	DAMPER	1	1	
17	92012-06010	BOLT, BUTTON HEAD	3	3	
18	3C5-Y8450-C0	COVER COMP. ASSY	1	1	
19	3C5-28390-B0	.GRAPHIC SET, COWLING	1	1	
20	5XC-2153E-10	.EMBLEM, YAMAHA	1	1	
21	90111-06038	BOLT, HEX. SOCKET BUTTON	2	2	
22	90387-061M0	COLLAR	2	2	
23	2EK-85111-00	REFLECTOR, FRONT 1	2		
	4AG-85111-00	REFLECTOR, 1		2	
24	95602-05100	NUT, U	2		
	95602-06100	NUT, U		2	
25	90387-05038	COLLAR	2		

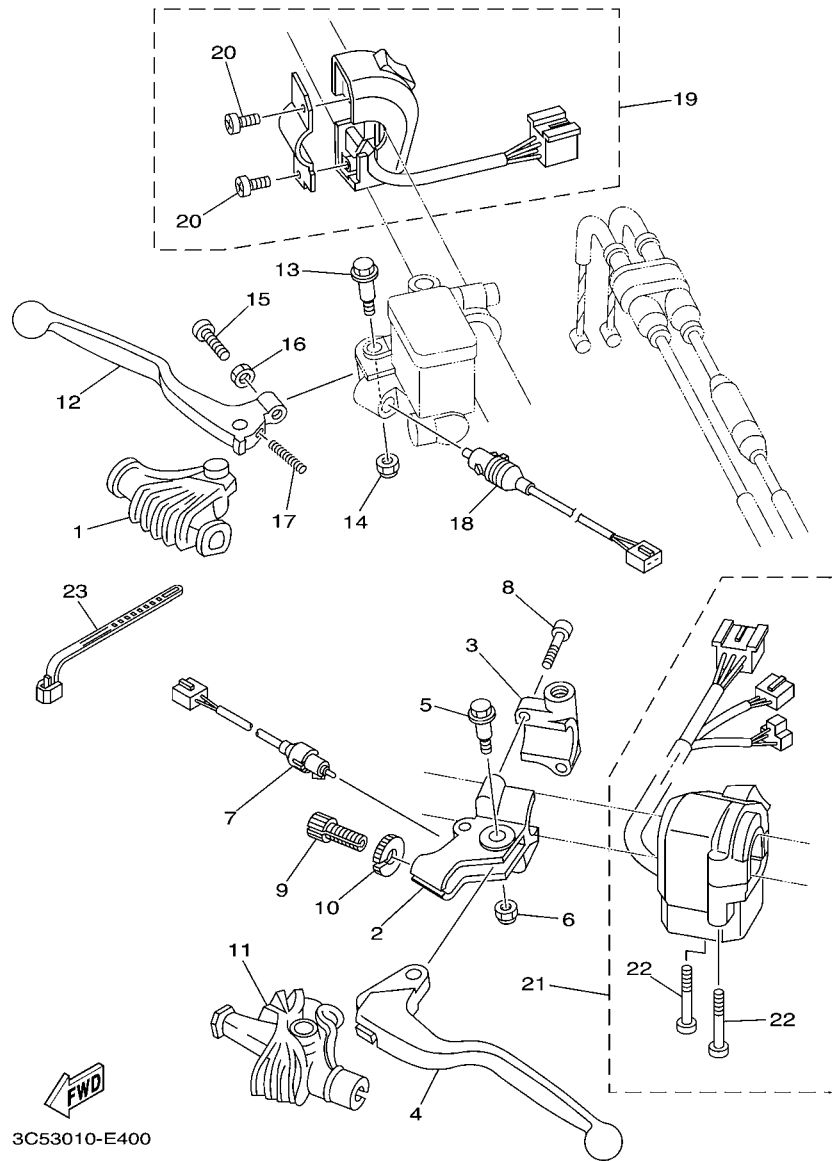

FIG. 42 HANDLE SWITCH & LEVER

REF. NO.	PART NO.	DESCRIPTION	3C5F	3C5G	REMARKS
1	1T5-26372-00	COVER, HANDLE LEVER 1	1	1	
2	5XT-82911-00	HOLDER, LEVER 1	1	1	
3	33G-82913-01	HOLDER, LEVER LOWER 1	1	1	
4	23X-83912-01	LEVER 1	1	1	
5	90109-06799	BOLT	1	1	
6	95607-06100	NUT, U	1	1	
7	3C5-82917-00	SWITCH	1	1	
8	91317-05020	BOLT	2	2	
9	90123-08046	BOLT	1	1	
10	90179-08148	NUT	1	1	
11	1E6-26372-00	COVER, HANDLE LEVER 1	1	1	
12	55Y-83922-00	LEVER 2	1	1	
13	90109-06577	BOLT	1	1	
14	95607-06100	NUT, U	1	1	
15	90149-06131	SCREW	1	1	
16	90170-06010	NUT	1	1	
17	90501-10312	SPRING, COMPRESSION	1	1	
18	3C5-83980-00	FRONT STOP SWITCH ASSY	1	1	
19	3C5-83975-00	SWITCH, HANDLE 2	1	1	
20	98507-05018	.SCREW, PAN HEAD	2	2	
21	3C5-83973-00	SWITCH, HANDLE 3	1	1	
22	98507-05030	.SCREW, PAN HEAD	2	2	
23	90464-25004	CLAMP	3	3	

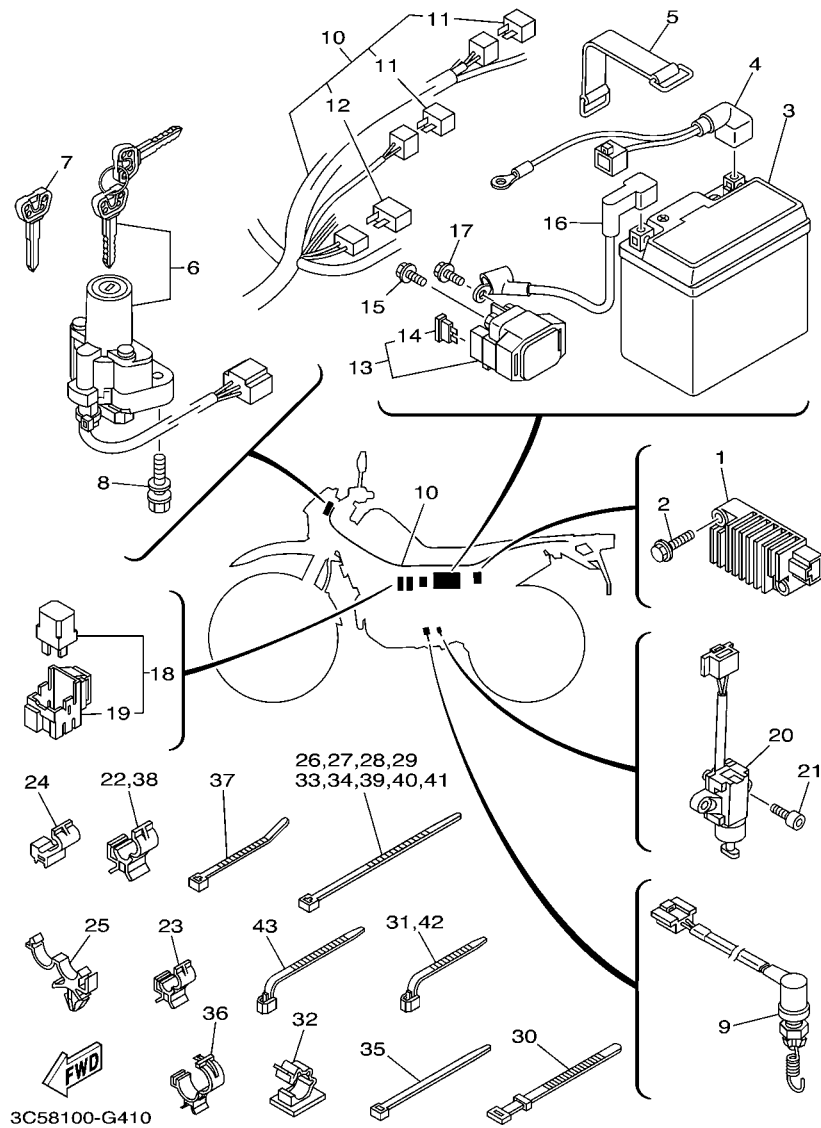

FIG. 43 ELECTRICAL 1

REF. NO.	PART NO.	DESCRIPTION	3C5F	3C5G	REMARKS
1	3TJ-81960-02	RECTIFIER & REGULATOR ASSY	1	1	
2	95027-06025	BOLT, FLANGE	2	2	
3	1S4-82100-10	BATTERY ASSY (YT Z7S)	1	1	
4	5XT-82116-00	WIRE, MINUS LEAD	1	1	
5	5JJ-82131-00	BAND, BATTERY	1	1	
6	3C5-82501-00	MAIN SWITCH STEERING LOCK	1	1	
7	4BH-82511-09	BLANK KEY	1	1	AP
8	90109-080G5	BOLT	2	2	
9	5C1-82530-00	STOP SWITCH ASSY	1	1	
10	3C5-82590-40	WIRE HARNESS ASSY	1		
	3C5-82590-50	WIRE HARNESS ASSY		1	
11	3WP-81980-00	.DIODE ASSY	2	2	
12	4WA-81980-00	.DIODE ASSY	1	1	
13	5XT-81940-02	STARTER RELAY ASSY	1	1	
14	2GH-82151-00	.FUSE (20A-BL)	2	2	
15	95027-06008	BOLT, FLANGE	1	1	
16	5XT-82115-00	WIRE, PLUS LEAD	1	1	
17	95027-06008	BOLT, FLANGE	1	1	
18	5JJ-81950-20	RELAY ASSY	2	2	
19	5JJ-81952-00	.HOLDER, RELAY	1	1	
20	5XT-82566-00	SWITCH, SIDE STAND	1	1	
21	90110-05227	BOLT, HEXAGON SOCKET HEAD	2	2	
22	90464-10190	CLAMP	1	1	
23	90464-17007	CLAMP	1	1	
24	90464-05188	CLAMP	1	1	
25	90464-16006	CLAMP	2	2	
26	1UA-82591-00	BAND	1	1	

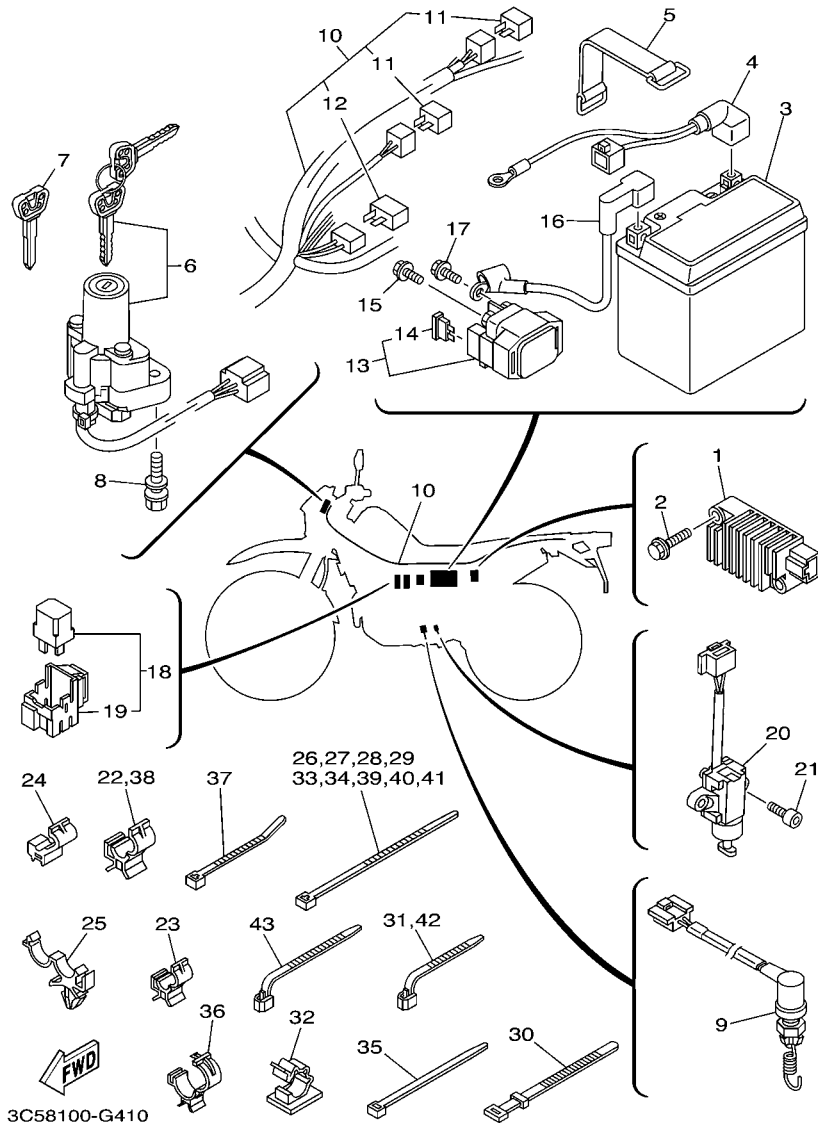
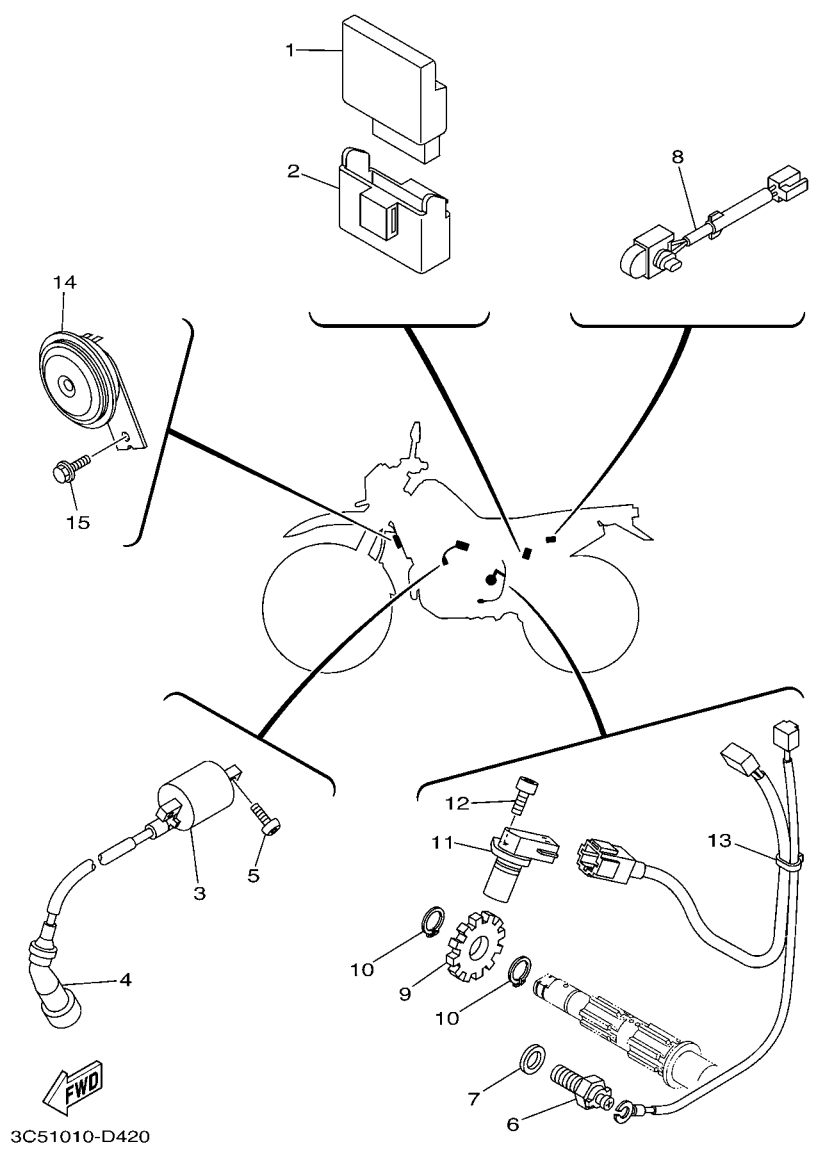

FIG. 43 ELECTRICAL 1

REF. NO.	PART NO.	DESCRIPTION	3C5F	3C5G	REMARKS
27	1UA-82591-00	BAND	1	1	
28	1UA-82591-00	BAND	1	1	
29	1UA-82591-00	BAND	1	1	
30	3TB-83936-00	BAND, SWITCH CORD	1	1	
31	90464-13077	CLAMP	1	1	
32	90464-13185	CLAMP	1	1	
33	1UA-82591-00	BAND	2	2	
34	1UA-82591-00	BAND	1	1	
35	5Y9-12491-00	CLAMP 1	1	1	
36	90464-20191	CLAMP	1	1	
37	90465-10098	CLAMP	2	2	
38	90464-10190	CLAMP	1	1	
39	1UA-82591-00	BAND	2	2	
40	1UA-82591-00	BAND	1	1	
41	1UA-82591-00	BAND	1	1	
42	90464-13077	CLAMP	1	1	
43	90464-13073	CLAMP	1	1	



3C51010-D420

FIG. 44 ELECTRICAL 2

REF. NO.	PART NO.	DESCRIPTION	3C5F	3C5G	REMARKS
1	3C5-85540-10	C.D.I. UNIT ASSY	1	1	
2	5XT-85546-00	BAND	1	1	
3	3NS-82310-10	IGNITION COIL ASSY	1	1	
4	3NS-82370-00	PLUG CAP ASSY	1	1	
5	90111-06017	BOLT,HEX. SOCKET BUTTON	2	2	
6	4KM-82540-00	NEUTRAL SWITCH ASSY	1	1	
7	90430-10148	GASKET	1	1	
8	5XT-82560-00	THERMO SWITCH ASSY	1	1	
9	3C5-8354W-00	ROTOR	1	1	
10	99009-17400	CIRCLIP	2	2	
11	1S4-83755-00	SENSOR, SPEED	1	1	
12	91312-06014	BOLT	1	1	
13	3C5-82309-00	WIRE, SUB LEAD	1	1	
14	3C5-83371-00	HORN	1	1	
15	95827-06010	BOLT, FLANGE	1	1	

NUMERICAL INDEX

PART NO.	REF. NO.	PART NO.	REF. NO.	PART NO.	REF. NO.	PART NO.	REF. NO.	PART NO.	REF. NO.	PART NO.	REF. NO.
3C5-11102-00	1 - 1	5XT-13329-00	6 - 4	5XT-14453-00	7 - 16	3XJ-16324-01	13 - 11	3C5-2137C-B0	24 - 27	240-23114-00	23 - 20
5XT-1111F-00	1 - 25	22F-13411-01	6 - 7	5XT-14457-00	7 - 14	4GY-16351-00	13 - 12	3C5-2137D-B0	24 - 36		23 - 40
5H0-11133-11	1 - 2	5D3-13440-00	6 - 8	5XT-14462-00	7 - 8	5XT-16356-00	13 - 14	5XT-2139X-01	17 - 28	3C5-23118-00	23 - 18
4KB-11145-00	5 - 5	5XT-13447-00	6 - 9	5XT-14472-00	7 - 10	4GY-16357-00	13 - 30		17 - 31		23 - 38
5XT-11165-00	1 - 15	5XT-13542-00	7 - 29	5LB-14589-00	8 - 5	1W1-16358-01	13 - 13	3C5-21511-10	18 - 1	5JX-23125-00	23 - 6
5C1-11166-00	1 - 18	5XT-13581-00	7 - 17	5LB-14592-00	8 - 30	4GY-16371-01	13 - 8	5XC-2153E-10	18 - 17		23 - 26
5XT-11181-00	1 - 6	5XT-13586-00	7 - 1	5XT-14611-10	9 - 1	5XT-16380-00	13 - 23		40 - 20	3C5-23126-10	23 - 2
5XT-11186-00	1 - 23	5LB-14105-00	8 - 3	3GD-14613-00	9 - 27	3XV-16383-00	13 - 19	3C5-21556-00	18 - 5	3C5-23136-10	23 - 22
5XT-11190-10	1 - 14	3C5-14148-00	8 - 38	3C5-14628-00	9 - 2	5NL-16384-00	13 - 20	5RU-21568-01	24 - 43	3C5-23141-00	23 - 16
5XT-11196-00	1 - 16	3C5-14196-00	8 - 39	5XT-1465R-00	9 - 7	51Y-17121-00	14 - 4	3C5-21611-20	18 - 9		23 - 36
3C5-11311-00	2 - 1	5LB-14216-00	8 - 20	5XT-1465T-00	9 - 8	5XT-17131-00	14 - 2	51Y-21639-00	18 - 23	5JX-23144-00	23 - 10
5XT-11351-00	2 - 2	5LB-14275-00	8 - 17	5XT-1465U-00	9 - 13	5XT-17151-10	14 - 3	3C5-21634-00	18 - 29		23 - 30
5XT-11400-00	3 - 1	5XT-14286-00	8 - 19	3C5-14711-10	9 - 14	3C5-17211-00	14 - 17	4G0-21639-00	18 - 13	5JX-23145-00	23 - 8
5XT-11454-00	3 - 18	5XT-14292-00	8 - 31	3C5-14711-20	9 - 14	5XT-17221-00	14 - 8	51Y-21639-00	17 - 13		23 - 28
5XT-11478-00	3 - 20	5LB-14293-00	8 - 6	3YF-14714-00	9 - 23	5XT-17231-00	14 - 13	3C5-2163A-00	18 - 12	4FY-23149-00	23 - 17
5XT-11496-00	3 - 22	3C5-14301-11	8 - 1	3C5-14728-00	9 - 16	5XT-17241-00	14 - 12	5XT-21642-02	18 - 14		23 - 37
1S4-11531-00	3 - 21	3C5-14301-20	8 - 1	5XT-14738-00	9 - 21	5XT-17251-10	14 - 11	3C5-21652-00	18 - 24	5K5-23149-00	23 - 7
5XT-11533-00	3 - 23	5XT-14321-00	8 - 27	5XT-14748-00	9 - 22	5BP-17285-00	14 - 16	3TT-21668-00	20 - 30		23 - 27
1S4-11536-00	3 - 17	5XT-14323-00	8 - 23	1RH-14752-01	9 - 24	3C5-17402-00	14 - 7	3TT-21668-10	20 - 31	5XT-23151-00	23 - 13
5BP-11549-00	3 - 13	5XT-14325-00	8 - 2	5XT-1479K-00	9 - 9	5XT-17411-00	14 - 1	4FD-21685-00	18 - 32		23 - 33
4XV-11603-00	3 - 10	5XT-14325-10	8 - 8	5C1-14803-00	7 - 28	5XT-17460-00	14 - 25	3C5-21731-00	19 - 8	4A1-23156-00	23 - 9
3C5-11631-00-A0	3 - 9	2JX-14333-00	8 - 28	5XT-14815-00	1 - 9	3C5-17558-00	14 - 21	5XT-21732-00	19 - 17		23 - 29
5H0-11633-00	3 - 11	5XT-14335-00	8 - 34	3C5-14871-00	1 - 7	5XT-18101-01	16 - 1	5XT-21735-00	19 - 18	1N1-23158-00	23 - 14
29U-11651-00	3 - 4	3C5-14336-00	8 - 18	5C1-14881-00	7 - 31	5XT-18110-10	16 - 7	3C5-2173E-B0	19 - 2		23 - 34
5BP-11681-00	3 - 2	5XT-14336-10	8 - 18	5C1-14882-01	7 - 33	5XT-18112-10	16 - 12	3C5-2173F-B0	19 - 4	3C5-23170-00	23 - 5
5H0-12111-02	4 - 1	5XT-14341-00	8 - 11	5LB-14936-00	8 - 16	1W6-18113-00	16 - 8	3C5-21741-00	19 - 9		23 - 25
11H-12113-00	4 - 4	5XT-14341-10	8 - 12	3C5-15100-03	10 - 1	5XT-18115-10	16 - 10	3C5-22110-00	20 - 1	5JX-23171-00	23 - 4
11H-12114-00	4 - 5	5LB-14342-17	8 - 14	5XT-15113-00	11 - 13	4TP-18140-00	16 - 2	401-22128-01	20 - 4		23 - 24
4G0-12116-01	4 - 3	288-14343-68	8 - 13	5XT-15316-00	11 - 15	4GY-18511-00	15 - 2	5JV-22141-00	20 - 22	5XT-23173-00	23 - 11
4G0-12117-00	4 - 7	5XT-14348-00	8 - 36	3Y1-15361-00	11 - 25	4GY-18512-00	15 - 3	3C5-22151-00	20 - 5		23 - 31
4G0-12118-00	4 - 8	5XT-1434A-00	8 - 15	5XT-15411-02	11 - 1	4GY-18513-00	15 - 4	5JG-22156-00	20 - 7	3C5-2317E-01	22 - 21
5H0-12119-00	4 - 6	3C5-14355-00	8 - 40	5XT-15415-00	11 - 28	5BP-18531-00	15 - 5	10V-22178-00	17 - 20	3C5-23191-10	23 - 41
5XT-12121-00	4 - 2	50M-14355-00	8 - 21	5XT-15421-01	11 - 17	5XT-18540-00	15 - 1	5XT-2217A-00	20 - 11	3C5-23192-00	23 - 42
5H0-12146-00	4 - 11	5LB-14357-00	8 - 29	5XT-15430-00	11 - 14	5XT-21107-00	17 - 40	3C5-2217F-00	20 - 17	5HP-2319U-00	22 - 16
36X-12151-00	4 - 9	1JK-14363-00	8 - 37	5XT-15441-02	10 - 10	3C5-2110M-01	17 - 27	10V-22184-00	17 - 21	3C5-23340-10	23 - 44
5H0-12156-00	4 - 10	5LB-14368-00	8 - 4	5XT-15451-00	11 - 6	3C5-2110N-01	17 - 30	5XT-22184-00	20 - 3	5RS-23346-00	23 - 45
5XT-12159-00	4 - 13	5XT-14371-10	8 - 33	5XT-15461-00	11 - 18	3C5-21110-30	17 - 1	5BT-22199-00	20 - 8	3C5-23348-10	22 - 22
5XT-12170-00	5 - 1	5XT-14374-00	8 - 35	5XT-15512-00	12 - 1	3C5-21140-20	17 - 3	3C5-22210-30	21 - 1	5XT-23363-00	23 - 12
5XT-12176-00	5 - 4	5LB-14384-00	8 - 22	5XT-15515-00	12 - 5	3C5-21140-30	17 - 3	3C5-22210-40	21 - 1		23 - 32
5XT-12210-00	5 - 12	5LB-14385-00	8 - 10	5XT-15517-00	12 - 3	3C5-21165-00	17 - 33	4AA-22259-40	21 - 2	1J7-23415-00	22 - 7
4FM-12213-00	5 - 13	5LB-14386-00	8 - 9	1VJ-15521-00	12 - 2	3C5-2117N-00	17 - 37	4AA-22259-60	21 - 2	3YF-23418-00	22 - 12
5BP-12231-00	5 - 10	5XT-14390-10	8 - 7	36Y-15521-01	12 - 4	5GK-2118K-00	24 - 44	34X-22311-00	20 - 25	3C5-23426-00	22 - 13
5XT-12241-00	5 - 11	5XT-14401-20	7 - 6	5BP-15590-00	12 - 8	5GK-2118K-10	24 - 43	3C5-23102-20	23 - 1	3C5-23435-00	22 - 14
5Y9-12491-00	18 - 35	5XT-14412-00	7 - 13	5XT-16111-00	13 - 1	5XT-21268-00	17 - 38	3C5-23103-20	23 - 21	4H7-23441-01-P5	22 - 18
	43 - 35	5XT-14421-01	7 - 7	5XT-16150-00	13 - 6	3C5-21275-00	17 - 34	3C5-23110-00	23 - 3	3C5-24110-10-P0	24 - 1
5XT-13161-00	6 - 15	5XT-1443E-00	7 - 21	30X-16154-00	13 - 7	4R8-21308-01	17 - 25		23 - 23		24 - 28
5XT-13300-01	6 - 1	5XT-14451-00	7 - 19	1KT-16321-00	13 - 9	3C5-21315-00	17 - 12	5JX-23111-00	23 - 19	3C5-24126-00	24 - 29
5BP-13326-01	6 - 2	5XT-14452-00	7 - 11	5DH-16321-00	13 - 10	3C5-21316-00	17 - 14		23 - 39	3C5-2414H-00	24 - 30

NUMERICAL INDEX

PART NO.	REF. NO.	PART NO.	REF. NO.	PART NO.	REF. NO.	PART NO.	REF. NO.	PART NO.	REF. NO.	PART NO.	REF. NO.
3C5-2414H-00	24 - 37	4JG-25412-00	28 - 12	1E6-26342-00	31 - 19	5C1-82530-00	43 - 9	3C5-83500-00	39 - 1	4JG-W0047-00	27 - 5
5EJ-2414H-00	7 - 24	3C5-25448-00	29 - 9	1E6-26372-00	42 - 11	4KM-82540-00	44 - 6	3C5-83500-20	39 - 1	3JD-W0047-51	30 - 7
	19 - 15	3C5-25448-10	28 - 10	1T5-26372-00	42 - 1	5XT-82560-00	44 - 8	4XV-83513-00	18 - 21	51L-W0048-00	27 - 10
3C5-2414J-00	24 - 31	3C5-2580T-00	27 - 3	3C5-27211-10	34 - 1	5XT-82566-00	43 - 20	3C5-83519-00	39 - 4	1UY-W0048-50	30 - 11
	24 - 38	3C5-2580W-01	30 - 5	5UN-27217-00	34 - 13	3C5-82590-40	43 - 10	3C5-8354W-00	44 - 9	4JG-W0057-00	27 - 4
3C5-2414K-00	24 - 32	5XT-25828-00	27 - 11	4SS-27218-00	34 - 8	3C5-82590-50	43 - 10	1S4-83755-00	44 - 11	5XT-W0057-50	30 - 6
3C5-2414N-00	24 - 33	3C5-2582T-00	27 - 1	2YK-27222-00	34 - 9	1UA-82591-00	24 - 19	5FU-83790-00	8 - 26	3C5-Y2171-F0	19 - 1
3C5-2414P-00	24 - 41	5XT-2582W-00	30 - 1	3KW-27234-00	34 - 14		43 - 26	23X-83912-01	42 - 4	3C5-Y2172-F0	19 - 3
3C5-2416F-00	24 - 42	5XT-25839-10	20 - 32	55V-27242-00	34 - 2		43 - 27	55Y-83922-00	42 - 12	3C5-Y217W-F0	24 - 26
3C5-24181-10	24 - 14	5XT-2583T-00	32 - 1	5XT-27261-00	34 - 25		43 - 28	3TB-83936-00	43 - 30	3C5-Y217X-F0	24 - 35
3C5-24182-10	24 - 16	5XT-2583V-10	34 - 6	3C5-27311-10	33 - 6		43 - 29	3C5-83973-00	42 - 21	3C5-Y8450-C0	40 - 18
3C5-24183-00	24 - 15	3GM-25852-22	32 - 4	5XT-27315-01	33 - 9		43 - 33	3C5-83975-00	42 - 19	90101-06043	5 - 15
3C5-24184-10	24 - 18	5UN-25852-50	34 - 10	3LD-27411-01	33 - 1		43 - 34	3C5-83980-00	42 - 18	90101-06053	18 - 26
3C5-24185-10	24 - 17	55U-25854-00	32 - 3	3LD-27421-01	33 - 2		43 - 39	3C5-84127-00	40 - 10	90101-10013	33 - 10
3C5-24186-00	24 - 21	5UN-25854-00	34 - 12	3XP-27431-02	33 - 13		43 - 40	3C5-84144-00	40 - 14	90101-10016	5 - 7
3C5-24188-00	24 - 20	5UN-2585B-00	34 - 11	3C5-27432-00	33 - 18		43 - 41	2F9-84314-00	40 - 2	90101-10659	21 - 4
31A-24188-01	19 - 19	56A-25867-00	32 - 6	5XT-27434-00	16 - 13	341-82594-00	7 - 5	3C5-84315-00	40 - 8	90101-12015	20 - 19
3C5-24500-00	24 - 2	3C5-25872-00	32 - 9	3XP-27441-02	33 - 19	5XT-82911-00	42 - 2	3C5-84320-00	40 - 1	90105-06057	7 - 26
1P6-24512-00	24 - 6	3C5-25873-00	34 - 18	3C5-27442-00	33 - 24	33G-82913-01	42 - 3	2F9-84331-00	40 - 5		19 - 20
3C5-24523-00	24 - 3	3C5-25875-00	22 - 2	4GY-27491-00	30 - 3	3C5-82917-00	42 - 7	341-84332-60	40 - 6	90105-06078	1 - 26
3C5-24524-00	24 - 8	3C5-25876-00	22 - 3	3C5-28100-00	17 - 39	3C5-83310-10	37 - 1	4B4-84334-00	40 - 7	90105-06125	36 - 7
3AJ-24534-01	24 - 4	3LC-25885-00	34 - 22	3C5-28390-B0	40 - 19	3C5-83310-20	38 - 1	3C5-84366-00	40 - 9	90105-06126	1 - 17
214-24535-00	8 - 32	3C5-25886-00	31 - 14	4D9-28415-00	18 - 27	306-83311-40	38 - 2	2F9-84375-00	40 - 3	90105-06170	18 - 30
3D5-24535-00	24 - 7	3C5-25887-00	34 - 23	3C5-81410-00	35 - 1		38 - 6	2F9-84397-01	40 - 4	90105-08073	9 - 32
5VK-24602-00	24 - 13	5JW-25914-10	27 - 6	5XT-81450-01	35 - 2		38 - 16	1M8-84521-40	41 - 2	90105-08102	17 - 17
3C5-2470F-00	25 - 2	3SP-25914-51	30 - 14	50M-81801-M0	36 - 2	256-83311-70	37 - 12	1M1-84521-60	41 - 2	90105-08160	1 - 11
5RU-24768-00	17 - 36	3JD-25917-00	30 - 9	5HP-81828-00	36 - 4		37 - 16	1M1-84523-60	41 - 3	90105-10110	17 - 8
3C5-24770-00	25 - 1	4TT-25919-00	27 - 9	5HP-8182M-00	36 - 3		38 - 12	1M1-84524-60	41 - 5	90105-10111	17 - 6
1KH-25104-00	26 - 6	3SP-25919-51	30 - 10	5XT-8183G-00	36 - 6	3C5-83320-10	37 - 5	3C5-84527-10	18 - 22	90105-10114	17 - 9
34X-25111-02-35	26 - 1	3SP-25924-51	30 - 13	3C5-81890-00	36 - 1	3C5-83320-20	38 - 5	3C5-84551-00	18 - 28	90105-10116	17 - 15
322-25118-00	26 - 11	3SP-25926-51	30 - 15	5XT-81940-02	43 - 13	3C5-83330-10	37 - 11	3C5-84559-00	40 - 16	90105-10118	17 - 7
4JG-25304-00	28 - 6	4TT-25937-00	27 - 7	5JJ-81950-20	43 - 18	3C5-83330-20	38 - 11	4FD-84559-00	18 - 31	90105-10300	17 - 5
4JG-25304-10	29 - 6	1UY-25937-51	30 - 8	5JJ-81952-00	43 - 19	1LJ-83332-00	37 - 7	56U-84710-41	41 - 1	90105-10430	3 - 14
5MP-25311-00-35	29 - 1	3C5-26111-00	31 - 1	3TJ-81960-02	43 - 1		37 - 13	1W9-84710-61	41 - 1	90105-10638	27 - 12
4JG-25311-02-35	28 - 1	4RR-26129-00	31 - 6	3WP-81980-00	43 - 11		38 - 13	1A2-84714-41	41 - 4	90105-10788	17 - 4
5XT-25364-00	29 - 10	4GY-26241-00	31 - 5	4WA-81980-00	43 - 12	51L-83332-01	38 - 3	256-84714-61	37 - 2	90105-12425	20 - 29
5HH-25381-00	26 - 13	4GY-26242-00	31 - 2	1S4-82100-10	43 - 3	4BE-83340-00	37 - 15		37 - 6	90105-12598	21 - 8
2K6-25381-10	28 - 19	5BE-26243-00	31 - 3	3C5-8210E-00	19 - 14	4FD-83340-00	38 - 15		41 - 4	90109-06084	24 - 23
	29 - 18	3Y1-26249-00	31 - 4	5XT-82115-00	43 - 16	1LJ-83342-00	37 - 3	3C5-84717-00	41 - 8	90109-06189	16 - 4
4JG-25383-00	28 - 16	3C5-26280-00	31 - 13	5XT-82116-00	43 - 4		37 - 17	2EK-85111-00	40 - 23	90109-06577	42 - 13
	29 - 15	3LN-26281-01	31 - 8	5JJ-82131-00	43 - 5		38 - 17	4AG-85111-00	40 - 23	90109-065G0	6 - 11
5XT-25383-00	28 - 15	3LN-26282-01	31 - 9	2GH-82151-00	43 - 14	51L-83342-01	38 - 7	3Y6-85130-02	41 - 6	90109-065G4	27 - 2
	29 - 14	3C5-26290-00	31 - 12	3C5-82309-00	44 - 13	4MY-83350-01	19 - 16	3C5-85540-10	44 - 1	90109-06799	42 - 5
5XT-25388-00	28 - 17	3Y1-26290-00	31 - 12	3NS-82310-10	44 - 3	10V-83365-00	37 - 10	5XT-85546-00	44 - 2	90109-080G5	43 - 8
	29 - 16	3Y1-26290-10	31 - 13	3NS-82370-00	44 - 4		38 - 10	5XT-W0041-00	32 - 2	90109-08105	13 - 24
5XT-25389-00	28 - 18	3C5-26302-00	31 - 7	3C5-82501-00	43 - 6	18G-83365-00	37 - 20	5XT-W0042-50	34 - 7	90109-085F5	33 - 14
	29 - 17	5XT-26331-01	31 - 17	5XT-82509-00	8 - 25		38 - 20	3C5-W0045-00	27 - 8		33 - 20
3Y1-25394-00	28 - 14	3C5-26335-00	31 - 18	4BH-82511-09	43 - 7	3C5-83371-00	44 - 14	5XT-W0046-50	30 - 12	90109-085G6	9 - 15

NUMERICAL INDEX

PART NO.	REF. NO.	PART NO.	REF. NO.	PART NO.	REF. NO.	PART NO.	REF. NO.	PART NO.	REF. NO.	PART NO.	REF. NO.
90110-05032	11 - 12	90179-25033	22 - 10	90206-14001	34 - 27	90430-06014	10 - 7	90480-01559	24 - 34	92907-10600	33 - 22
90110-05227	43 - 21	90179-25615	22 - 9	90209-18208	14 - 14		11 - 24		24 - 39	93102-12224	13 - 28
90110-06161	35 - 4	90183-06023	7 - 20	90209-23241	14 - 9	90430-06156	6 - 6	90480-10334	7 - 36	93102-14209	16 - 6
90110-06169	35 - 3	90185-10060	33 - 11	90214-16063	13 - 3	90430-08119	6 - 19		19 - 12	93102-25226	14 - 24
90110-08053	12 - 9	90201-05015	9 - 5	90215-12272	3 - 26		13 - 25	90480-13398	18 - 8	93106-20021	26 - 4
90111-05011	24 - 40		9 - 11	90215-16289	13 - 21	90430-10005	32 - 11	90480-14011	22 - 24	93106-22032	28 - 4
90111-06008	11 - 29	90201-05016	9 - 6	90215-16293	13 - 4		34 - 21	90480-14555	39 - 3		29 - 4
90111-06017	44 - 5	90201-05017	9 - 10	90215-23265	14 - 26	90430-10148	44 - 7	90501-07629	3 - 6	93109-17071	20 - 13
90111-06038	40 - 21	90201-06055	18 - 16	90240-07105	3 - 5	90430-10171	6 - 17	90501-10312	42 - 17		20 - 16
90111-08019	9 - 30	90201-06058	19 - 7	90240-08124	34 - 15	90430-12213	10 - 15	90501-22721	3 - 24	93210-07135	6 - 12
90116-08010	29 - 13	90201-06063	19 - 21	90240-10101	33 - 4	90445-057G5	7 - 25	90501-23598	13 - 17	93210-09165	4 - 12
90116-08023	1 - 28	90201-06074	24 - 24	90280-05013	3 - 16	90445-10007	24 - 11	90504-18005	33 - 15	93210-11453	5 - 3
90116-08218	28 - 11	90201-08008	29 - 11	90282-05013	3 - 28	90445-10041	24 - 11		33 - 21	93210-13657	2 - 4
90119-05005	20 - 26	90201-08016	8 - 24	90282-05077	13 - 2	90445-22327	33 - 8	90506-23008	34 - 29	93210-14369	11 - 5
90119-06094	20 - 9	90201-08083	34 - 16	90338-06004	22 - 20	90450-47001	7 - 4	90506-35473	33 - 7	93210-19123	11 - 27
90119-06096	18 - 4	90201-08326	9 - 29	90338-26004	17 - 2	90450-56004	7 - 23	90508-14352	34 - 3	93210-25711	36 - 5
	18 - 7	90201-083P5	33 - 17	90340-12059	10 - 14	90461-08001	10 - 9	90508-203B3	13 - 26	93210-32172	11 - 3
90119-06184	25 - 3		33 - 23	90340-14151	11 - 4	90462-08225	10 - 8	90508-20583	33 - 3	93210-35537	7 - 2
90123-08046	42 - 9	90201-08609	1 - 12	90340-20002	11 - 26	90462-10043	10 - 12	90508-26020	16 - 3	93210-54001	1 - 24
90146-06014	19 - 10	90201-086P8	17 - 19	90340-32116	11 - 2	90464-05188	18 - 34	90560-15290	26 - 3	93210-54175	6 - 10
90149-06093	6 - 5	90201-08753	17 - 23	90383-17001	20 - 15		43 - 24	90560-15313	28 - 2	93210-74M68	11 - 30
90149-06108	24 - 9	90201-08784	16 - 15	90386-18099	20 - 2	90464-10190	43 - 22		29 - 2	93211-05471	1 - 21
90149-06131	42 - 15	90201-087A9	9 - 31	90387-05038	40 - 25		43 - 38	91311-08025	23 - 15	93306-00320	14 - 6
90149-06298	17 - 29	90201-10118	34 - 20	90387-05383	40 - 13	90464-13073	43 - 43		23 - 35	93306-20204	5 - 2
	17 - 32	90201-10135	34 - 26	90387-0602Y	18 - 18	90464-13077	43 - 31	91312-06014	44 - 12	93306-20205	26 - 2
	19 - 6	90201-101J1	17 - 11	90387-06048	19 - 11		43 - 42	91312-06020	7 - 3	93306-20212	28 - 3
	24 - 25		21 - 6	90387-06066	19 - 23	90464-13185	43 - 32	91314-06016	1 - 8		29 - 3
90149-06302	34 - 30	90201-102R1	3 - 15	90387-06107	18 - 11	90464-15192	1 - 20	91314-06020	6 - 14	93306-20332	14 - 22
90149-08268	30 - 2	90201-10591	5 - 8	90387-06117	18 - 3	90464-16006	43 - 25	91314-06025	5 - 14	93306-20427	14 - 5
90151-06008	14 - 20	90201-12699	20 - 21	90387-061M0	40 - 22	90464-16012	31 - 16	91314-06065	2 - 3	93306-20532	14 - 23
90151-06018	17 - 26		20 - 28	90387-06217	40 - 25	90464-17007	43 - 23	91314-06070	6 - 13	93306-30214	3 - 19
90153-06002	1 - 4	90201-126A7	20 - 24	90387-065G0	22 - 23	90464-20191	43 - 36	91314-08045	1 - 13	93306-37814	3 - 8
90154-06020	9 - 12		21 - 10	90387-06681	18 - 2	90464-25004	42 - 23	91317-05014	20 - 6	93310-225N0	12 - 7
90159-06010	13 - 18	90201-13013	21 - 5		18 - 6	90465-10098	40 - 15	91317-05020	42 - 8	93310-530J3	3 - 3
90164-05014	39 - 2	90201-15014	28 - 20	90387-06737	20 - 10		43 - 37	91317-08030	22 - 19	93315-11206	13 - 29
90170-06010	42 - 16		29 - 19	90387-06M21	18 - 25	90465-16011	11 - 11	91401-16012	34 - 17	93315-31750	20 - 12
90170-06022	16 - 11	90201-15797	26 - 12	90387-06M77	18 - 25	90467-08092	7 - 30	91401-20012	34 - 5	93332-00079	22 - 1
90170-06128	4 - 14	90201-177G4	14 - 18	90387-08024	17 - 22		7 - 35	91401-25015	33 - 5		22 - 6
90170-08258	28 - 13	90201-25291	12 - 6	90387-10003	33 - 12	90467-09006	24 - 12	91701-06022	34 - 4	93410-17037	14 - 19
90170-12370	3 - 27	90201-256K5	22 - 8	90387-123V9	20 - 18	90467-11106	7 - 22	92012-06010	40 - 17	93410-22039	14 - 15
90170-16326	13 - 22	90202-05187	9 - 19	90387-126X9	20 - 14	90467-12053	1 - 19	92012-08020	33 - 25	93410-26067	14 - 10
90170-16425	13 - 5	90202-05188	9 - 20	90387-127W0	21 - 3		7 - 27	92014-06016	30 - 4	93440-10085	1 - 3
90179-08148	42 - 10	90202-05193	24 - 10	90387-15600	26 - 10	90467-13064	7 - 32	92902-05600	40 - 12	93450-17044	3 - 12
90179-08674	17 - 18	90202-10165	24 - 22	90401-08007	6 - 18	90467-14057	7 - 34	92902-06200	13 - 15	93511-32017	13 - 31
90179-10658	17 - 10	90202-26142	22 - 11	90401-10003	6 - 16	90467-18196	7 - 18	92907-06600	9 - 26	93602-13177	3 - 7
	17 - 16	90206-06090	9 - 4	90401-10172	32 - 10	90468-16191	34 - 28		18 - 20	93604-10011	5 - 6
90179-18552	14 - 27		9 - 18		34 - 19	90480-01141	19 - 13		32 - 8	93605-10090	3 - 25
90179-22007	22 - 15	90206-12074	16 - 14	90430-06014	1 - 5	90480-01558	19 - 5	92907-10600	33 - 16	93608-43228	16 - 5

NUMERICAL INDEX

PART NO.	REF. NO.	PART NO.	REF. NO.	PART NO.	REF. NO.	PART NO.	REF. NO.	PART NO.	REF. NO.	PART NO.	REF. NO.
93900-00022	29 - 8	95317-06700	16 - 9	98706-04012	32 - 5						
94112-18008	29 - 7	95602-05100	40 - 24	98901-04006	8 - 8						
94112-187Y4	28 - 7	95602-06100	40 - 24	98907-06012	7 - 15						
94127-21008	26 - 7	95604-12200	20 - 23	98980-06012	9 - 3						
94127-217Y3	26 - 7	95607-06100	42 - 6		9 - 17						
94227-21123	26 - 8		42 - 14	99009-11400	6 - 3						
94227-21286	26 - 8	95607-08100	29 - 12	99009-17400	44 - 10						
94232-18287	28 - 8	95607-12200	21 - 9	99009-20500	13 - 27						
94327-21168	26 - 9	95607-14100	26 - 14	99530-10114	10 - 2						
94330-21084	26 - 9	95607-14200	28 - 21		11 - 7						
94335-18167	28 - 9		29 - 20		11 - 19						
94416-21536	26 - 5	95614-10100	21 - 7	99530-14016	1 - 10						
94421-18468	28 - 5	95617-12100	20 - 20		10 - 16						
94421-18562	29 - 5		20 - 27								
94581-36128	28 - 22	95704-08500	9 - 28								
	29 - 21	95707-05500	41 - 7								
94582-19104	5 - 9	95707-06500	18 - 33								
94701-00345	1 - 27	95802-06010	7 - 37								
95022-06010	10 - 13	95807-06008	34 - 24								
95024-06016	11 - 16	95807-06014	19 - 22								
95024-06020	1 - 22	95807-06016	18 - 15								
95024-06025	11 - 20	95807-08016	17 - 35								
95024-06030	11 - 9	95812-06016	10 - 11								
95024-06035	11 - 21	95827-06010	44 - 15								
95024-06040	11 - 8	95827-06012	22 - 5								
95024-06045	10 - 3	97002-05020	40 - 11								
	11 - 10	97007-06025	32 - 7								
95024-06050	11 - 22	97007-06030	18 - 19								
95024-06055	10 - 6	97022-06030	18 - 26								
	11 - 23	97027-06020	16 - 16								
95024-06060	10 - 4	97706-40620	38 - 4								
95024-06070	10 - 5		38 - 8								
95024-08040	22 - 17	97707-40520	37 - 4								
95027-06008	43 - 15		37 - 8								
	43 - 17		37 - 14								
95027-06010	22 - 4		37 - 18								
95027-06012	17 - 41		38 - 14								
	18 - 10		38 - 18								
95027-06025	31 - 15	97707-50025	7 - 9								
	43 - 2	97707-50520	7 - 12								
95027-06035	17 - 42	97801-05008	8 - 2								
95027-06040	22 - 25	98502-03008	24 - 5								
95027-08045	17 - 24	98506-04016	23 - 43								
95302-06600	13 - 16	98507-05018	42 - 20								
95307-12700	37 - 9	98507-05020	31 - 10								
	37 - 19	98507-05025	31 - 11								
	38 - 9	98507-05030	42 - 22								
	38 - 19	98507-06010	9 - 25								