



# PARTS CATALOGUE

## XT660R'08 (5VKA) SOUTH AFRICA

---

1G5VK-300E1

( 2G5VK-300E1 )

XT660R  
PARTS CATALOGUE  
©2007 by MBK Industrie  
1st edition, October 2007  
All rights reserved.  
Any reprinting or unauthorized use  
without the written permission of  
MBK Industrie  
is expressly prohibited.

**A3**

# FOREWORD

This Parts Catalogue is related to the parts for the model(s) on the cover page. When you are ordering replacement parts, please refer to this Parts Catalogue and quote both part numbers and part names correctly.

1. Modifications or additions which have been made after the issue of the Parts Catalogue will be announced in the Parts News.

It is advisable that you make the necessary corrections to the Parts Catalogue according to the Parts News.

2. Abbreviations

The following abbreviations are used in this Parts Catalogue.

“UR” Use specified parts number.

“UN” Use as many as needed.

“AP” Alternate Parts

“LM” Locally Made (Parts need to be ordered locally)

“F#” Frame No. (Applicable machine No.)

“O/S” Over Size

3. The number of components for assembly

- Parts, which are to be supplied in an assembly, are listed with a dot (.) in front of the part name as shown below.
- The numeral appearing to the right of each component part indicates the quantity of parts for each assembly unit.

PART NO.	DESCRIPTION	Q'TY	REMARKS
2F5-83310-60	FRONT FLASHER LIGHT ASSY	2	
115-83311-60	.BULB (6V-18W)	1	

4. Applicable colours of graphics are represented in the “REMARKS” as shown below.

PART NO.	DESCRIPTION	Q'TY	REMARKS
2N4-24110-00-X5	FUEL TANK COMP.	2	MXR
3J1-24240-10	.GRAPHIC, FUEL TANK	1	FOR MXR

5. Note that the illustrations for reference in finding parts numbers are not to be used for assembling. When assembling, please use the applicable service manual.

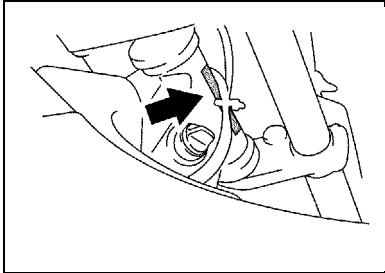
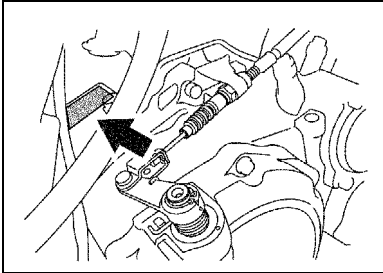
6. The asterisk (\*) before a reference number indicates modified items after the first edition.

# FOREWORD

7. Applicable Serial No.

Engine Serial No.

Frame Serial No.



8. Applicable Colour Code (The (\*) mark shows Model colour.)

Abbreviation	Colour Name	Colour Code
DPBSE(*)	DEEP PURPLISH BLUE SOLID E	0583
MBL2	MAT BLACK 2	0582
S8	SILVER 8	0895
YB(*)	YAMAHA BLACK	0033

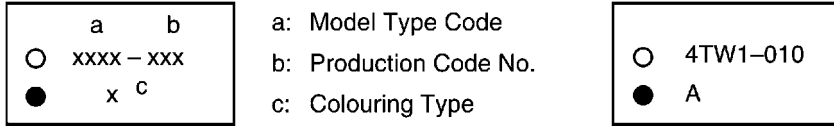
9. Quantity Column Information

Column No.	Name Of Q'ty Column	Destination
1	01	010-020
2	02	030-050
3	03	040-080
4	04	060-070-
5	05	090

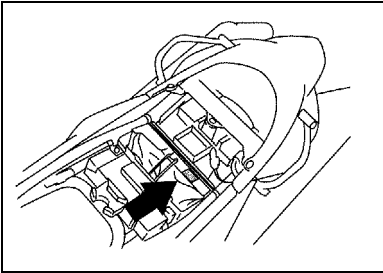
# MODEL LABEL

(1) A label called "Model Label" is affixed in the location as indicated in (3) below. When using this parts catalogue, please be sure to cross-reference the "model code – production code No." in the catalogue with the "model code – production code No." indicated on the Model Label affixed onto the product concerned.

(2) "Model Label" Indication



(3) Model Label Affixing Location



(4) Colouring Information

Model Code	Colouring Type Code	Colour Code	Colour Name	Abbreviation
5VKA	A	0583	DEEP PURPLISH BLUE SOLID E	DPBSE
	B	0033	YAMAHA BLACK	YB

(5) Model Code – Production Code Number of Model Listed in This Parts Catalogue

Model Code	Production Code No.	Country (destination)	Model Code	Production Code No.	Country (destination)
5VKA	010	EUROPE			
	020	BELGIUM			
		NETHERLANDS			
	030	CZECHO			
		DENMARK			
		HUNGARY			
		NORWAY			
	040	SPAIN			
		050	FINLAND		
	GREECE				
	ISRAEL				
	POLAND				
	RUSSIAN FEDERATION				
	SLOVENIA				
	060	TURKEY			
		UNITED KINGDOM			
	070	IRELAND			
		SOUTH AFRICA			
	080	PORTUGAL			
090		CHILE			
	MEXICO				
	VENEZUELA				

# CONTENTS

## ENGINE

CYLINDER HEAD .....	B2
CYLINDER .....	B3
CRANKSHAFT & PISTON .....	B4
VALVE .....	B5
CAMSHAFT & CHAIN .....	B6
WATER PUMP .....	B7
RADIATOR & HOSE .....	B8
OIL PUMP .....	B9
INTAKE .....	B11
INTAKE 2 .....	B13
EXHAUST .....	B14
CRANKCASE .....	C2
CRANKCASE COVER 1 .....	C3
STARTER CLUTCH .....	C5
CLUTCH .....	C6
TRANSMISSION .....	C8
SHIFT CAM & FORK .....	C10
SHIFT SHAFT .....	C11

## CHASSIS

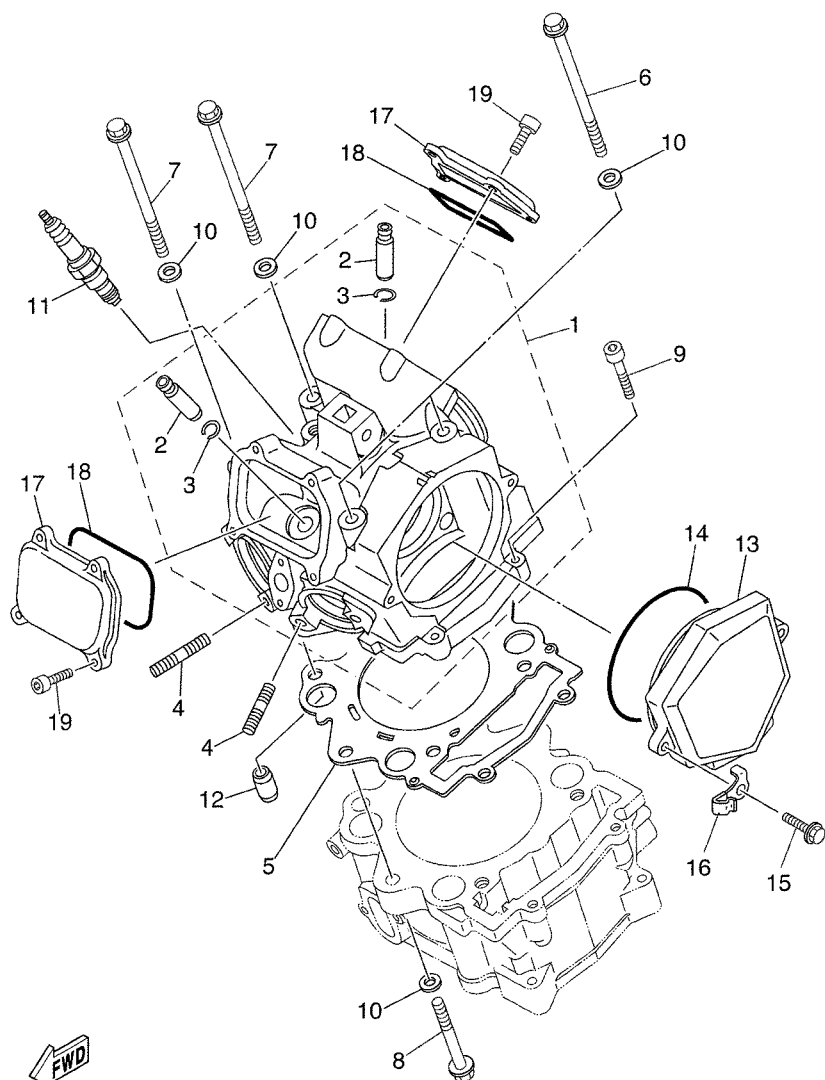
FRAME .....	C12
FENDER .....	C14
SIDE COVER .....	D2
REAR ARM .....	D3
REAR SUSPENSION .....	D5
STEERING .....	D6
FRONT FORK .....	D8
FUEL TANK .....	D10
SEAT .....	D12
FRONT WHEEL .....	D14
FRONT BRAKE CALIPER .....	D15
REAR WHEEL .....	E2
REAR BRAKE CALIPER .....	E4
STEERING HANDLE & CABLE .....	E5
FRONT MASTER CYLINDER .....	E6
STAND & FOOTREST .....	E7
REAR MASTER CYLINDER .....	E9
COWLING 1 .....	E11
GENERATOR .....	E12
FLASHER LIGHT .....	E13
METER .....	E14

HEADLIGHT .....	E15
TAILLIGHT .....	F2
HANDLE SWITCH & LEVER .....	F3
ELECTRICAL 1 .....	F4
ELECTRICAL 2 .....	F6

## INDEX

NUMERICAL INDEX .....	M1
-----------------------	----

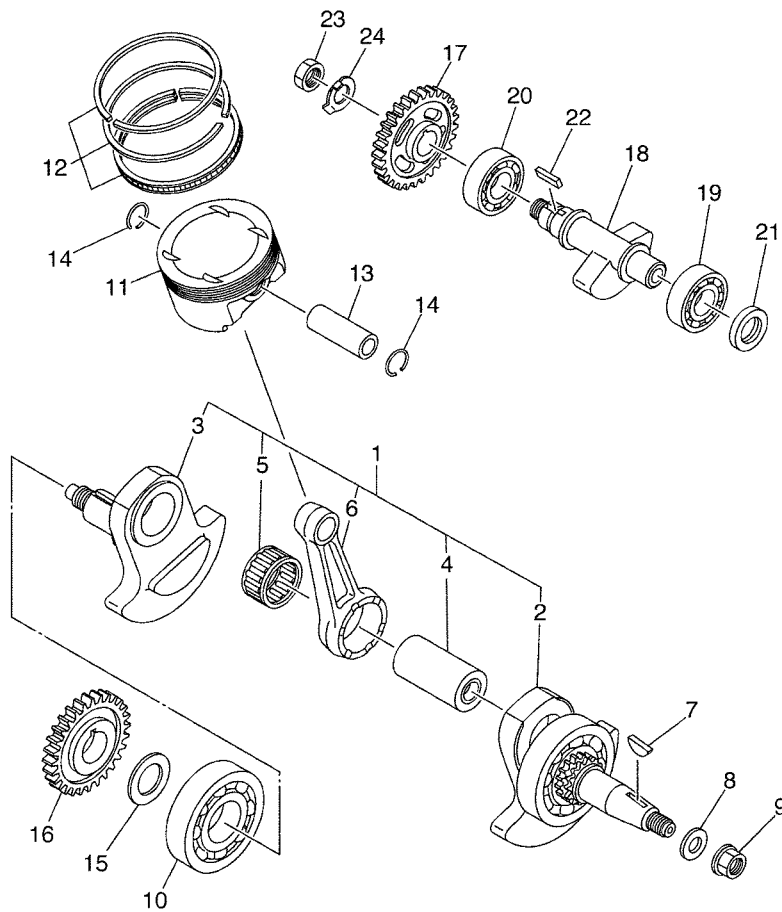
FIG. 1 CYLINDER HEAD



5VK8300-F010

REF. NO.	PART NO.	DESCRIPTION	01	02	03	04	05	REMARKS
1	5VK-E1101-00	CYLINDER HEAD ASSY	1	1	1	1	1	
2	4G0-11133-11	.GUIDE, VALVE 1	4	4	4	4	4	
3	93440-10X00	.CIRCLIP	4	4	4	4	4	
4	95617-08618	BOLT, STUD	4	4	4	4	4	
5	5VK-11181-00	GASKET, CYLINDER HEAD 1	1	1	1	1	1	
6	90105-09002	BOLT, FLANGE	2	2	2	2	2	
7	90105-09004	BOLT, FLANGE	2	2	2	2	2	
8	90105-09003	BOLT, FLANGE	2	2	2	2	2	
9	91317-06030	BOLT	2	2	2	2	2	
10	90201-096J9	WASHER, PLATE	6	6	6	6	6	
11	94701-00X09	PLUG, SPARK (NGK CR7E)	1	1	1	1	1	
12	93612-16X00	PIN, DOWEL	2	2	2	2	2	
13	5VK-E1185-00	COVER, CYLINDER HEAD SIDE 1	1	1	1	1	1	
14	93210-96X00	O-RING	1	1	1	1	1	
15	90105-06X06	BOLT, FLANGE	2	2	2	2	2	
16	90465-10044	CLAMP	1	1	1	1	1	
17	5VK-E1186-00	COVER, CYLINDER HEAD SIDE 2	2	2	2	2	2	
18	93210-78X00	O-RING	2	2	2	2	2	
19	91317-06018	BOLT	8	8	8	8	8	





5VK1300-C030

FIG. 3 CRANKSHAFT & PISTON

REF. NO.	PART NO.	DESCRIPTION	01	02	03	04	05	REMARKS
1	5VK-11400-00	CRANKSHAFT ASSY	1	1	1	1	1	
2	5VK-11401-09	.CRANK SUB ASSY 1	1	1	1	1	1	
3	5VK-11422-00	.CRANK 2	1	1	1	1	1	
4	5VK-11681-00	.PIN, CRANK 1	1	1	1	1	1	
5	93310-84010	.BEARING	1	1	1	1	1	
6	5VK-11651-00	.ROD, CONNECTING	1	1	1	1	1	
7	90280-05001	KEY, WOODRUFF	1	1	1	1	1	
8	90201-16013	WASHER, PLATE	1	1	1	1	1	
9	90179-16448	NUT	1	1	1	1	1	
10	93306-308Y0	BEARING	1	1	1	1	1	
11	5VK-11631-00	PISTON (STD)	1	1	1	1	1	
12	5VK-11603-00	PISTON RING SET (STD)	1	1	1	1	1	
13	5VK-11633-00	PIN, PISTON	1	1	1	1	1	
14	93450-24824	CIRCLIP	2	2	2	2	2	
15	90201-30X00	WASHER, PLATE	1	1	1	1	1	
16	5VK-E1536-00	GEAR, DRIVE	1	1	1	1	1	
17	5VK-E1531-00	GEAR, BALANCE WEIGHT	1	1	1	1	1	
18	5VK-E1454-00	WEIGHT 1	1	1	1	1	1	
19	93306-305YJ	BEARING	1	1	1	1	1	
20	93306-305YH	BEARING	1	1	1	1	1	
21	93101-25106	OIL SEAL	1	1	1	1	1	
22	90282-05058	KEY, STRAIGHT	1	1	1	1	1	
23	90170-18003	NUT	1	1	1	1	1	
24	90215-18X00	WASHER, LOCK	1	1	1	1	1	

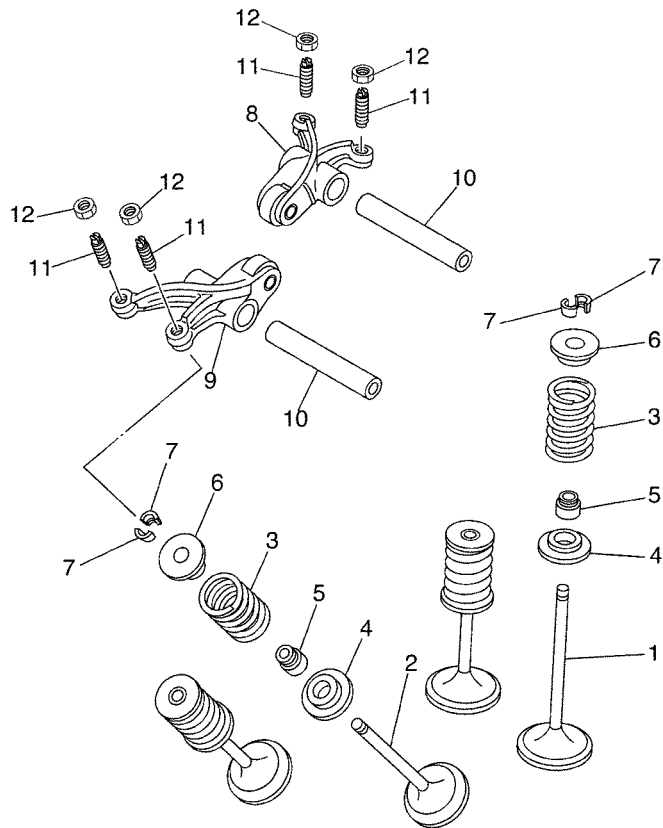


FIG. 4 VALVE

REF. NO.	PART NO.	DESCRIPTION	01	02	03	04	05	REMARKS
1	5VK-12111-00	VALVE, INTAKE	2	2	2	2	2	
2	5VK-12121-00	VALVE, EXHAUST	2	2	2	2	2	
3	5VK-12113-00	SPRING, VALVE INNER	4	4	4	4	4	
4	3YF-12116-00	SEAT, VALVE SPRING	4	4	4	4	4	
5	5H0-12119-00	SEAL, VALVE STEM	4	4	4	4	4	
6	3YF-12117-01	RETAINER, VALVE SPRING	4	4	4	4	4	
7	4G0-12118-00	COTTER, VALVE	8	8	8	8	8	
8	5VK-E2151-00	ARM, VALVE ROCKER	1	1	1	1	1	
9	5VK-E2161-00	ARM, VALVE ROCKER 2	1	1	1	1	1	
10	5VK-12146-00	SHAFT, ROCKER	2	2	2	2	2	
11	5BP-12159-01	SCREW, VALVE ADJUSTING	4	4	4	4	4	
12	90170-06128	NUT	4	4	4	4	4	

 5VK1300-C040

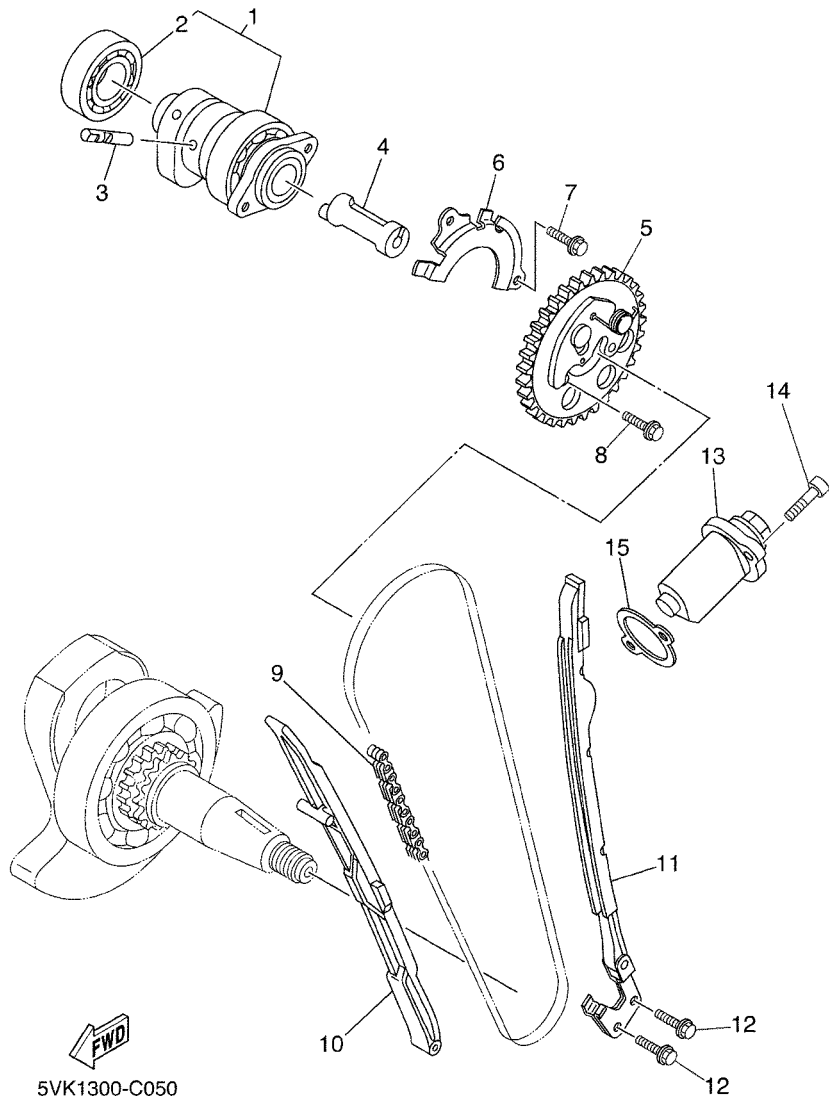
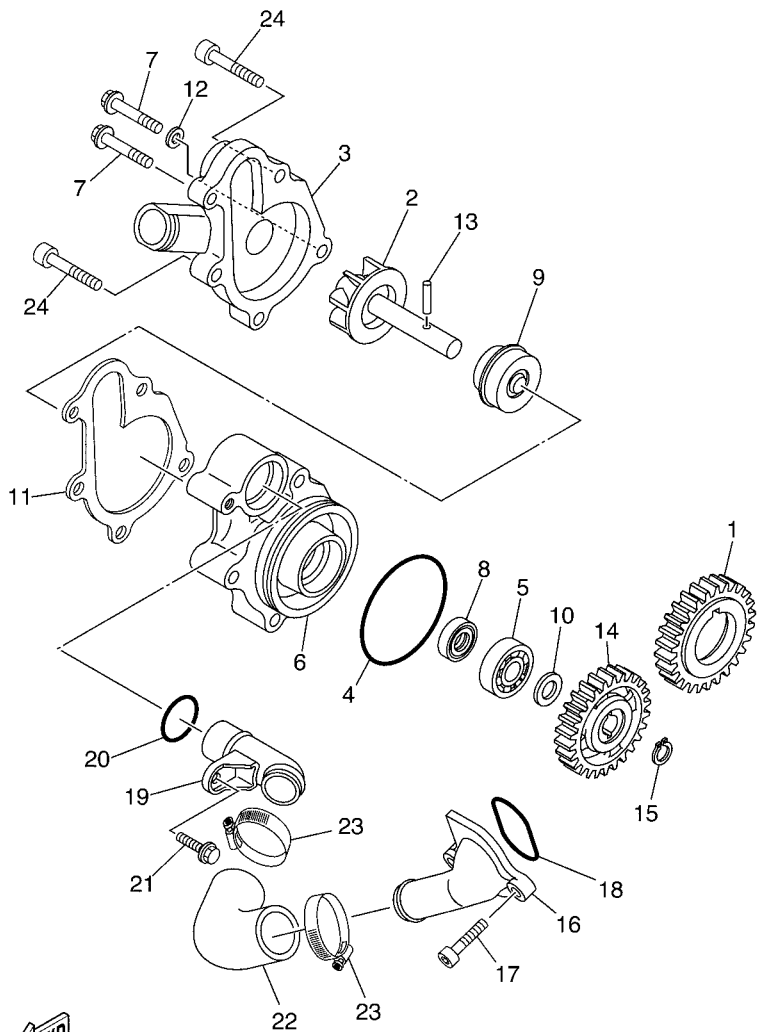


FIG. 5 CAMSHAFT & CHAIN

REF. NO.	PART NO.	DESCRIPTION	01	02	03	04	05	REMARKS
1	5VK-E2170-10	CAMSHAFT ASSY 1	1	1	1	1	1	
2	93306-07209	.BEARING	1	1	1	1	1	
3	5VK-12284-00	PIN, DECOMPRESSION LEVER	1	1	1	1	1	
4	5VK-12290-00	LEVER, DECOMPRESSION SPRING	1	1	1	1	1	
5	5VK-12280-01	DECOMPRESSION ASSY	1	1	1	1	1	
6	5VK-E111F-00	PLATE	1	1	1	1	1	
7	95027-06012	BOLT, FLANGE	2	2	2	2	2	
8	90105-07004	BOLT, FLANGE	2	2	2	2	2	
9	94591-57126	CHAIN (98XRH2010-126M)	1	1	1	1	1	
10	5VK-12231-00	GUIDE, STOPPER 1	1	1	1	1	1	
11	5VK-12241-00	GUIDE, STOPPER 2	1	1	1	1	1	
12	90119-06X05	BOLT, WITH WASHER	2	2	2	2	2	
13	3TB-12210-00	TENSIONER ASSY, CAM CHAIN	1	1	1	1	1	
14	91317-06025	BOLT	2	2	2	2	2	
15	4DW-12213-00	GASKET, TENSIONER CASE	1	1	1	1	1	

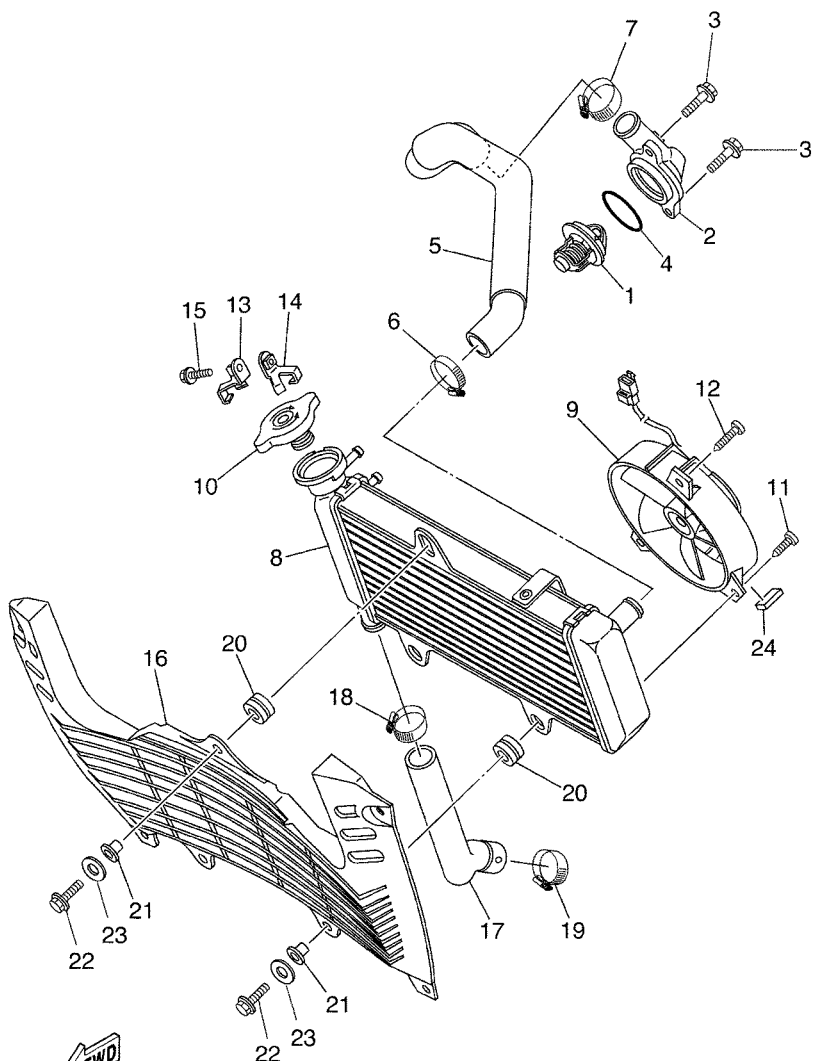
FIG. 6 WATER PUMP



  
5VK6300-E060

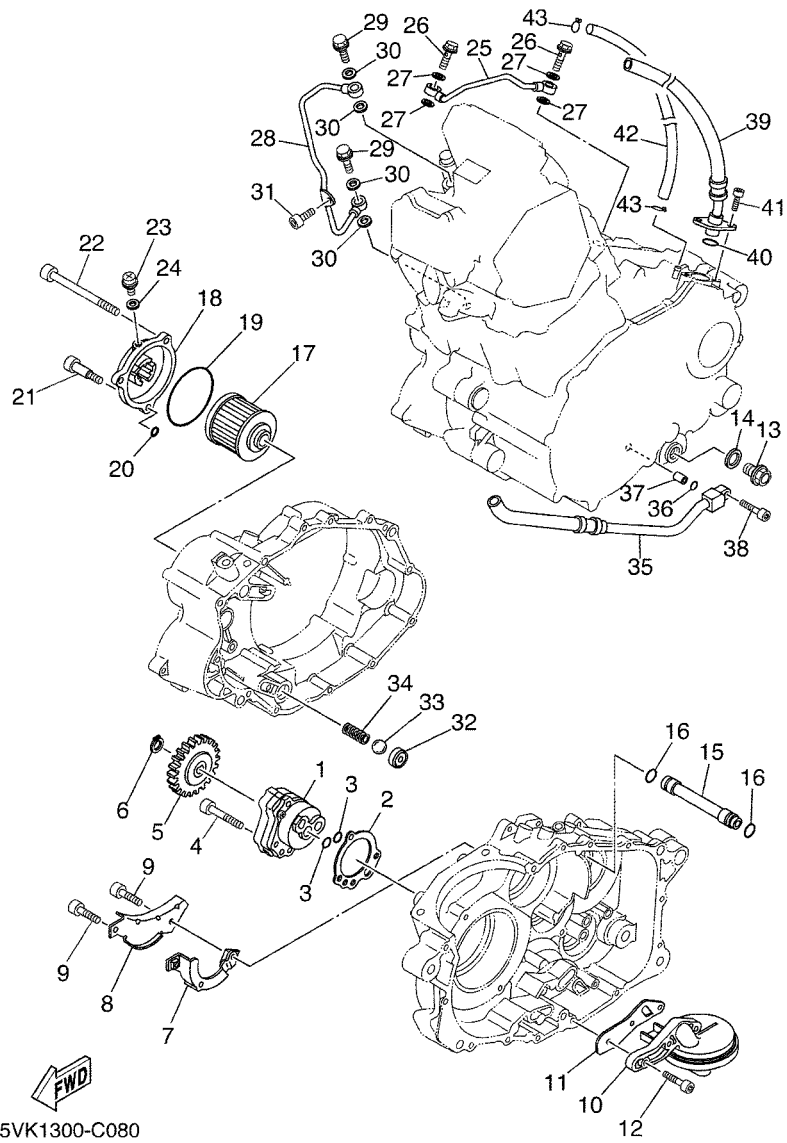
REF. NO.	PART NO.	DESCRIPTION	01	02	03	04	05	REMARKS
1	5VK-12436-00	GEAR, DRIVE	1	1	1	1	1	
2	5VK-12450-00	IMPELLER SHAFT ASSY	1	1	1	1	1	
3	5VK-12422-00	COVER, HOUSING	1	1	1	1	1	
4	93210-61750	O-RING	1	1	1	1	1	
5	93306-00106	BEARING	1	1	1	1	1	
6	5VK-12421-00	HOUSING, WATER PUMP	1	1	1	1	1	
7	95027-06025	BOLT, FLANGE	2	2	2	2	2	
8	93101-12173	OIL SEAL	1	1	1	1	1	
9	11H-12438-10	SEAL, MECHANICAL	1	1	1	1	1	
10	90201-12541	WASHER, PLATE	1	1	1	1	1	
11	5VK-12428-00	GASKET, HOUSING COVER 2	1	1	1	1	1	
12	90430-06014	GASKET	1	1	1	1	1	
13	93603-16219	PIN, DOWEL	1	1	1	1	1	
14	5VK-12459-00	GEAR, IMPELLER SHAFT	1	1	1	1	1	
15	99009-12400	CIRCLIP	1	1	1	1	1	
16	5VK-E2469-00	JOINT 1	1	1	1	1	1	
17	91317-06020	BOLT	2	2	2	2	2	
18	93210-33X00	O-RING	1	1	1	1	1	
19	5VK-12481-00	PIPE 1	1	1	1	1	1	
20	93210-21X00	O-RING	1	1	1	1	1	
21	91317-06012	BOLT	1	1	1	1	1	
22	5VK-E2577-00	HOSE 2	1	1	1	1	1	
23	90450-31X00	HOSE CLAMP ASSY	2	2	2	2	2	
24	91317-06050	BOLT	3	3	3	3	3	

FIG. 7 RADIATOR & HOSE



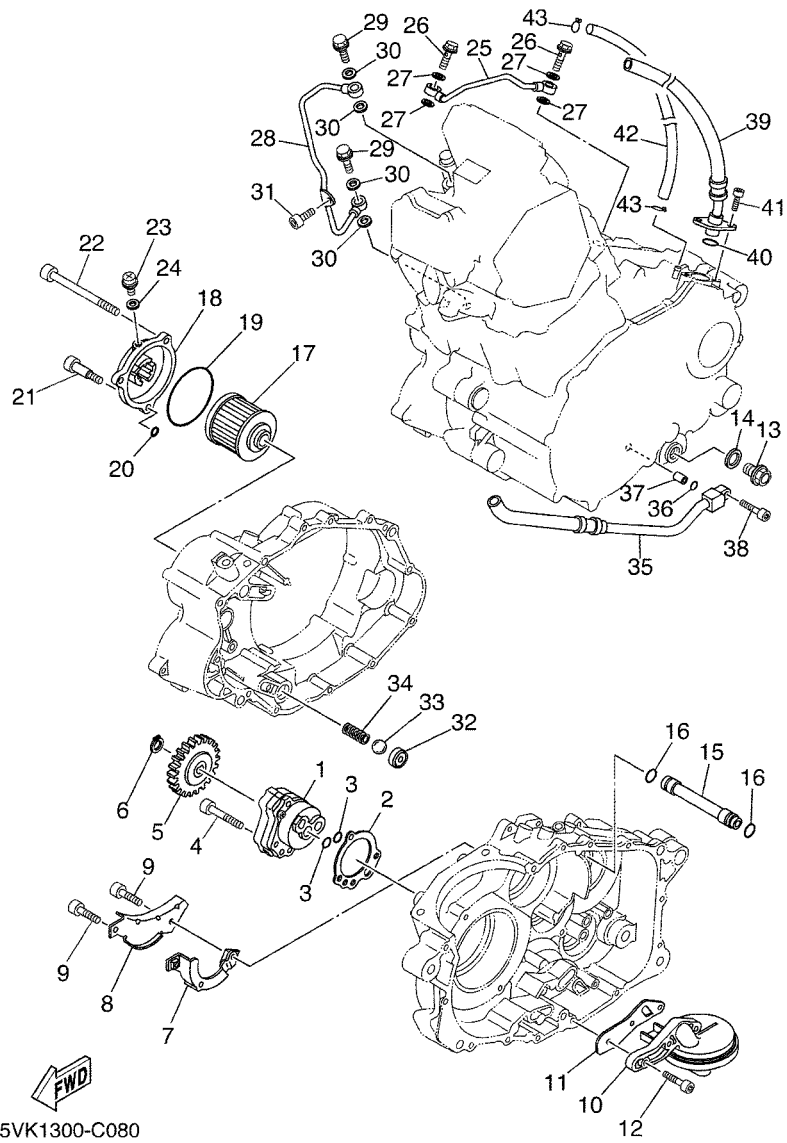
5VK8300-F070

REF. NO.	PART NO.	DESCRIPTION	01	02	03	04	05	REMARKS
1	5VK-12410-00	THERMOSTAT ASSY	1	1	1	1	1	
2	5VK-E2413-00	COVER, THERMOSTAT	1	1	1	1	1	
3	90105-06X06	BOLT, FLANGE	2	2	2	2	2	
4	93210-41X00	O-RING	1	1	1	1	1	
5	5VK-E2578-10	HOSE 3	1	1	1	1	1	
6	90450-32X04	HOSE CLAMP ASSY	1	1	1	1	1	
7	90450-32X04	HOSE CLAMP ASSY	1	1	1	1	1	
8	5VK-E2461-00	RADIATOR ASSY	1	1	1	1	1	
9	5VK-E2405-00	BLOWER ASSY	1	1	1	1	1	
10	5VK-E2462-00	CAP, RADIATOR	1	1	1	1	1	
11	90169-05802	TAPPING SCREW	1	1	1	1	1	
12	90169-05801	TAPPING SCREW	2	2	2	2	2	
13	5VK-E2437-00	STOPPER	1	1	1	1	1	
14	5VK-E2437-10	STOPPER	1	1	1	1	1	
15	95807-06010	BOLT, FLANGE	1	1	1	1	1	
16	5VK-E2498-00	PROTECTOR	1	1	1	1	1	
17	5VK-E2579-10	HOSE 4	1	1	1	1	1	
18	90450-32X04	HOSE CLAMP ASSY	1	1	1	1	1	
19	90450-32X04	HOSE CLAMP ASSY	1	1	1	1	1	
20	90480-18276	GROMMET	3	3	3	3	3	
21	90387-06042	COLLAR	3	3	3	3	3	
22	97007-06025	BOLT	3	3	3	3	3	
23	92907-06600	WASHER, PLATE	3	3	3	3	3	
24	1FK-84527-00	DAMPER	1	1	1	1	1	



**FIG. 8 OIL PUMP**

REF. NO.	PART NO.	DESCRIPTION	01	02	03	04	05	REMARKS
1	5LP-13300-00	OIL PUMP ASSY	1	1	1	1	1	
2	5LP-13329-00	GASKET, PUMP COVER	1	1	1	1	1	
3	93210-13X00	O-RING	2	2	2	2	2	
4	92017-06035	BOLT, BUTTON HEAD	3	3	3	3	3	
5	3AJ-13325-00	GEAR, PUMP DRIVEN	1	1	1	1	1	
6	93410-11X00	CIRCLIP	1	1	1	1	1	
7	5VK-E3356-00	COVER, PUMP 2	1	1	1	1	1	
8	5VK-E3327-00	COVER, PUMP GEAR	1	1	1	1	1	
9	91317-05008	BOLT	2	2	2	2	2	
10	5VK-WE343-00	STRAINER COMP.	1	1	1	1	1	
11	5VK-E3415-00	SEAL, OIL STRAINER	1	1	1	1	1	
12	91317-06020	BOLT	3	3	3	3	3	
13	90340-14132	PLUG, STRAIGHT SCREW	1	1	1	1	1	
14	214-11198-01	GASKET	1	1	1	1	1	
15	5VK-E3181-00	PIPE, DELIVERY 3	1	1	1	1	1	
16	93210-11X00	O-RING	2	2	2	2	2	
17	4X7-13440-01	ELEMENT ASSY, OIL CLEANER	1	1	1	1	1	
18	2WK-13447-00	COVER, OIL ELEMENT	1	1	1	1	1	
19	93210-64X01	O-RING	1	1	1	1	1	
20	93210-07X01	O-RING	1	1	1	1	1	
21	90109-06419	BOLT	1	1	1	1	1	
22	91317-06095	BOLT	2	2	2	2	2	
23	90149-05110	SCREW	1	1	1	1	1	
24	90430-05X00	GASKET	1	1	1	1	1	
25	5VK-13161-00	PIPE, DELIVERY 1	1	1	1	1	1	
26	90401-08133	BOLT, UNION	2	2	2	2	2	
27	90430-08X01	GASKET	4	4	4	4	4	



5VK1300-C080

FIG. 8 OIL PUMP

REF. NO.	PART NO.	DESCRIPTION	01	02	03	04	05	REMARKS
28	5VK-13171-00	PIPE, DELIVERY 2	1	1	1	1	1	
29	90401-10096	BOLT, UNION	2	2	2	2	2	
30	90430-10X00	GASKET	4	4	4	4	4	
31	91317-06012	BOLT	1	1	1	1	1	
32	583-13113-00	SEAT, CHECK BALL	1	1	1	1	1	
33	93503-08007	BALL	1	1	1	1	1	
34	90501-04X01	SPRING, COMPRESSION	1	1	1	1	1	
35	5VK-13464-00	HOSE, OIL 1	1	1	1	1	1	
36	93210-10X00	O-RING	1	1	1	1	1	
37	91810-14X00	PIN, DOWEL	1	1	1	1	1	
38	91317-06025	BOLT	1	1	1	1	1	
39	5VK-13465-00	HOSE, OIL 2	1	1	1	1	1	
40	93210-15X00	O-RING	1	1	1	1	1	
41	91317-06016	BOLT	2	2	2	2	2	
42	90445-11033	HOSE	1	1	1	1	1	
43	90467-10008	CLIP	1	1	1	1	1	

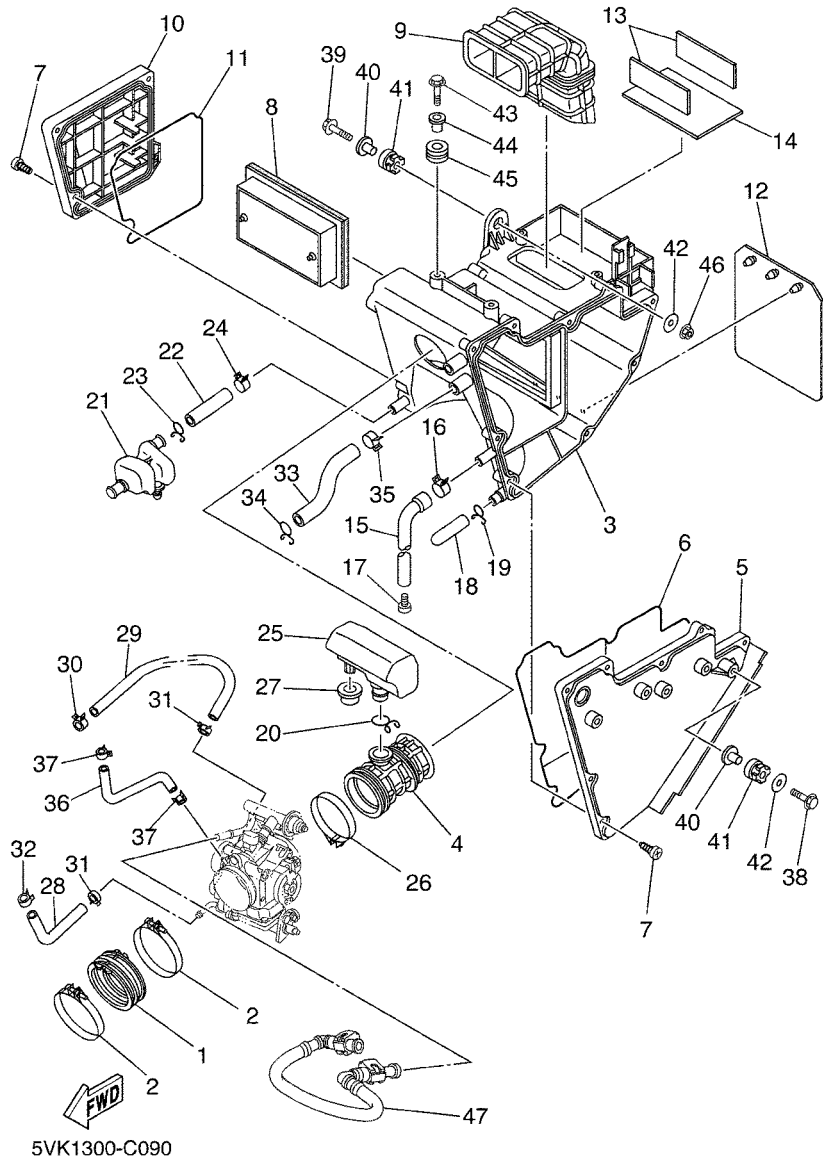


FIG. 9 INTAKE

REF. NO.	PART NO.	DESCRIPTION	01	02	03	04	05	REMARKS
1	5VK-13586-00	JOINT, CARBURETOR 1	1	1	1	1	1	
2	90450-72001	HOSE CLAMP ASSY	2	2	2	2	2	
3	5VK-E4411-00	CASE, AIR CLEANER 1	1	1	1	1	1	
4	5VK-E4453-00	JOINT, AIR CLEANER 1	1	1	1	1	1	
5	5VK-E441A-00	COVER, CLEANER CASE 1	1	1	1	1	1	
6	5VK-E4452-00	SEAL	1	1	1	1	1	
7	9770M-50025	SCREW, TAPPING	13	13	13	13	13	
8	5VK-E4451-00	ELEMENT, AIR CLEANER	1	1	1	1	1	
9	5VK-E4437-00	DUCT	1	1	1	1	1	
10	5VK-E441E-00	COVER, CLEANER CASE 2	1	1	1	1	1	
11	5VK-E4457-00	SEAL	1	1	1	1	1	
12	5VK-F1621-00	FLAP	1	1	1	1	1	
13	5VK-H2121-00	PAD, BATTERY	2	2	2	2	2	
14	5VK-H2122-00	SEAT, BATTERY	1	1	1	1	1	
15	5VK-E443E-00	PIPE, DRAIN	1	1	1	1	1	
16	90467-13062	CLIP	1	1	1	1	1	
17	90338-08801	PLUG	1	1	1	1	1	
18	5LW-E443E-00	PIPE, DRAIN	1	1	1	1	1	
19	90467-12800	CLIP	1	1	1	1	1	
20	90467-23800	CLIP	1	1	1	1	1	
21	5VK-E5371-00	BREATHER	1	1	1	1	1	
22	5VK-E1167-00	PIPE, BREATHER 2	1	1	1	1	1	
23	90467-14800	CLIP	1	1	1	1	1	
24	90467-17801	CLIP	1	1	1	1	1	
25	5VK-E3591-00	CHAMBER, AIR 2	1	1	1	1	1	
26	90450-59001	HOSE CLAMP ASSY	1	1	1	1	1	
27	90480-20566	GROMMET	1	1	1	1	1	

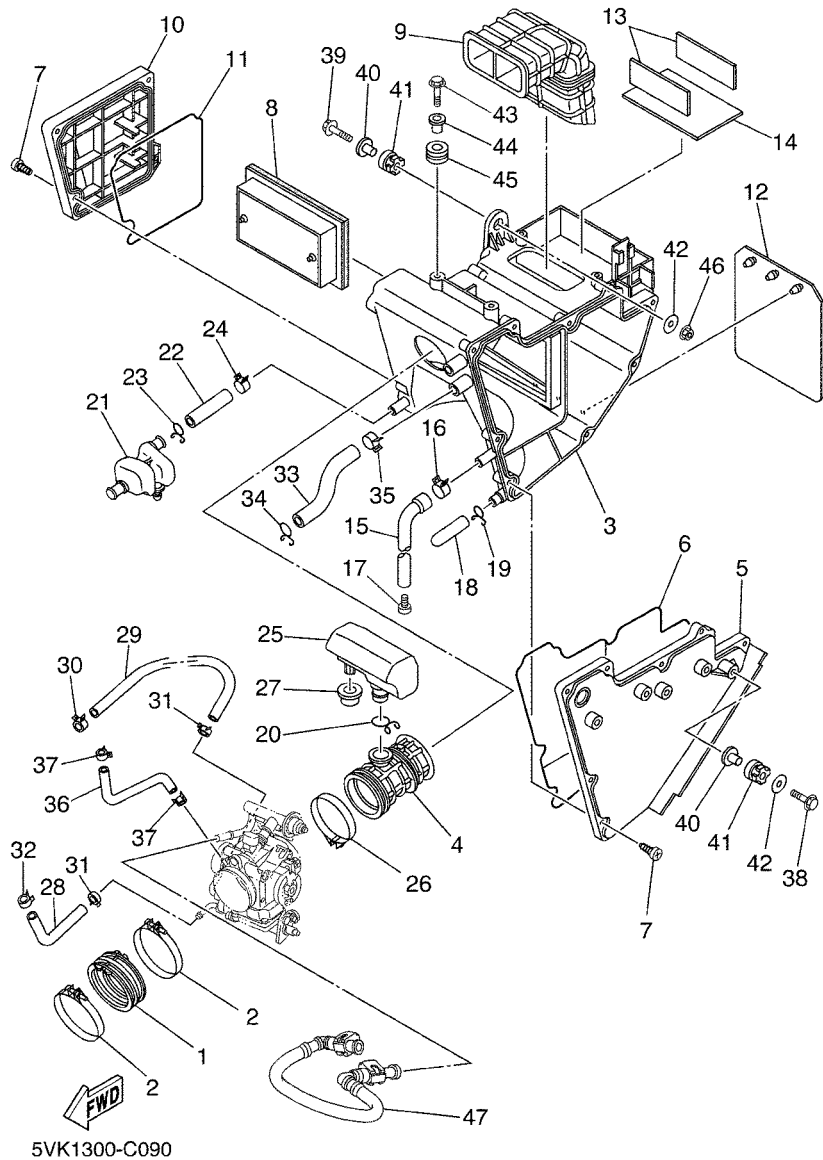
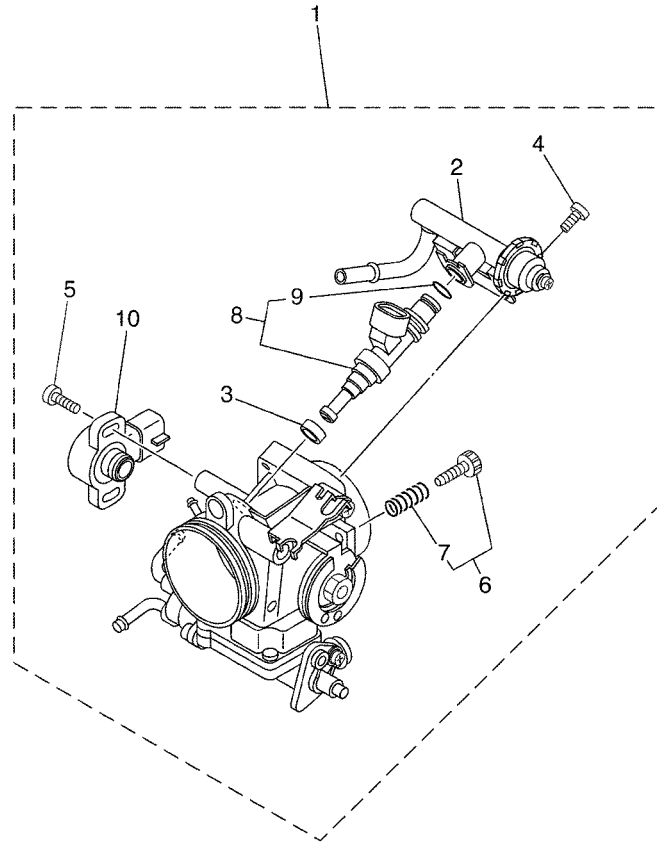


FIG. 9 INTAKE

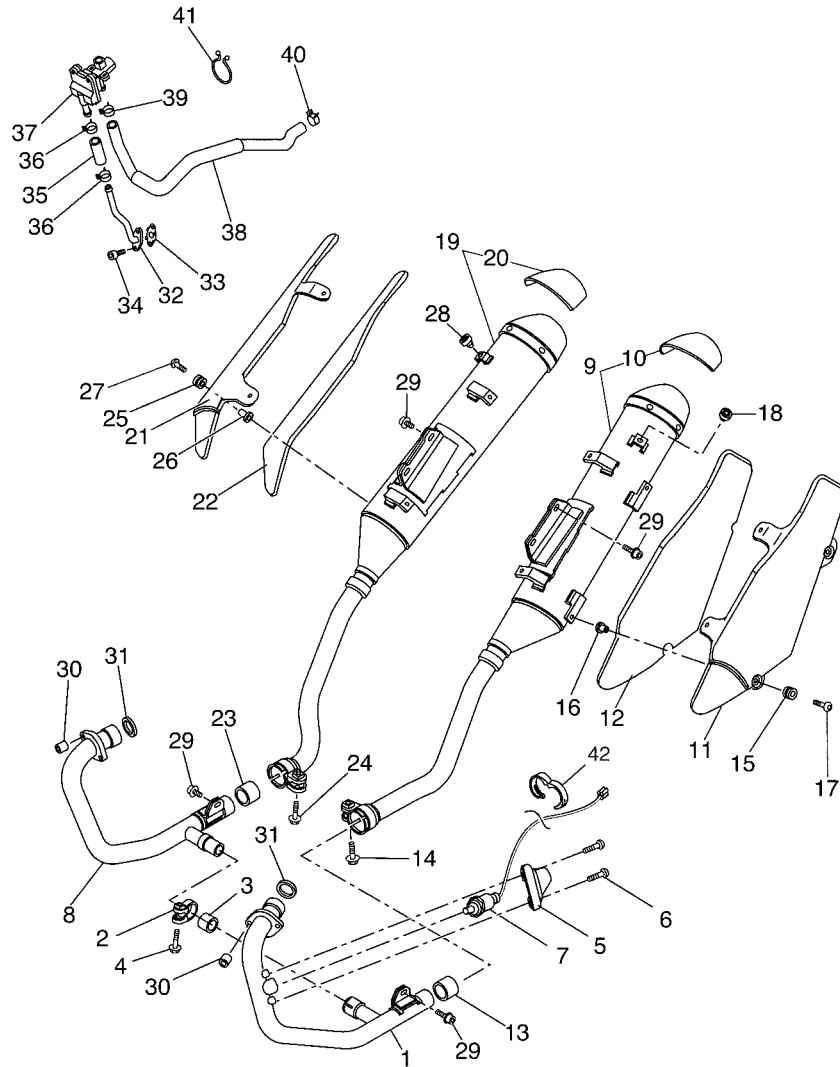
REF. NO.	PART NO.	DESCRIPTION	01	02	03	04	05	REMARKS
28	5VK-E243A-10	HOSE 1	1	1	1	1	1	
29	90445-12004	HOSE	1	1	1	1	1	
30	90467-11090	CLIP	1	1	1	1	1	
31	90467-11108	CLIP	2	2	2	2	2	
32	90467-11108	CLIP	1	1	1	1	1	
33	5VK-E3545-00	HOSE 1	1	1	1	1	1	
34	90467-170A2	CLIP	1	1	1	1	1	
35	90467-17128	CLIP	1	1	1	1	1	
36	5VK-13542-00	HOSE, VACUUM SENSING 1	1	1	1	1	1	
37	90467-07138	CLIP	2	2	2	2	2	
38	95827-06025	BOLT, FLANGE	1	1	1	1	1	
39	95827-06030	BOLT, FLANGE	1	1	1	1	1	
40	90387-075H4	COLLAR	2	2	2	2	2	
41	90480-15001	GROMMET	2	2	2	2	2	
42	90201-064K6	WASHER, PLATE	2	2	2	2	2	
43	95827-06020	BOLT, FLANGE	2	2	2	2	2	
44	90387-07037	COLLAR	2	2	2	2	2	
45	90480-18276	GROMMET	2	2	2	2	2	
46	95704-06500	NUT, FLANGE	1	1	1	1	1	
47	5VK-13971-00	PIPE, FUEL 1	1	1	1	1	1	

FIG. 10 INTAKE 2



REF. NO.	PART NO.	DESCRIPTION						REMARKS
			01	02	03	04	05	
1	5VK-13750-11	THROTTLE BODY ASSY	1	1	1	1	1	
2	5VK-13160-00	.DELIVERY PIPE ASSY 1	1	1	1	1	1	
3	90430-09002	.GASKET	1	1	1	1	1	
4	98507-06012	.SCREW, PAN HEAD	2	2	2	2	2	
5	8CC-14216-10	.SCREW	2	2	2	2	2	
6	5VK-14503-00	.ADJUST SCREW SET	1	1	1	1	1	
7	5VK-14531-00	..SPRING, ADJUST SCREW	1	1	1	1	1	
8	5VK-13761-00	.INJECTOR	1	1	1	1	1	
9	558-14147-00	..O-RING	1	1	1	1	1	
10	3P6-85885-00	.THROTTLE SENSOR ASSY	1	1	1	1	1	

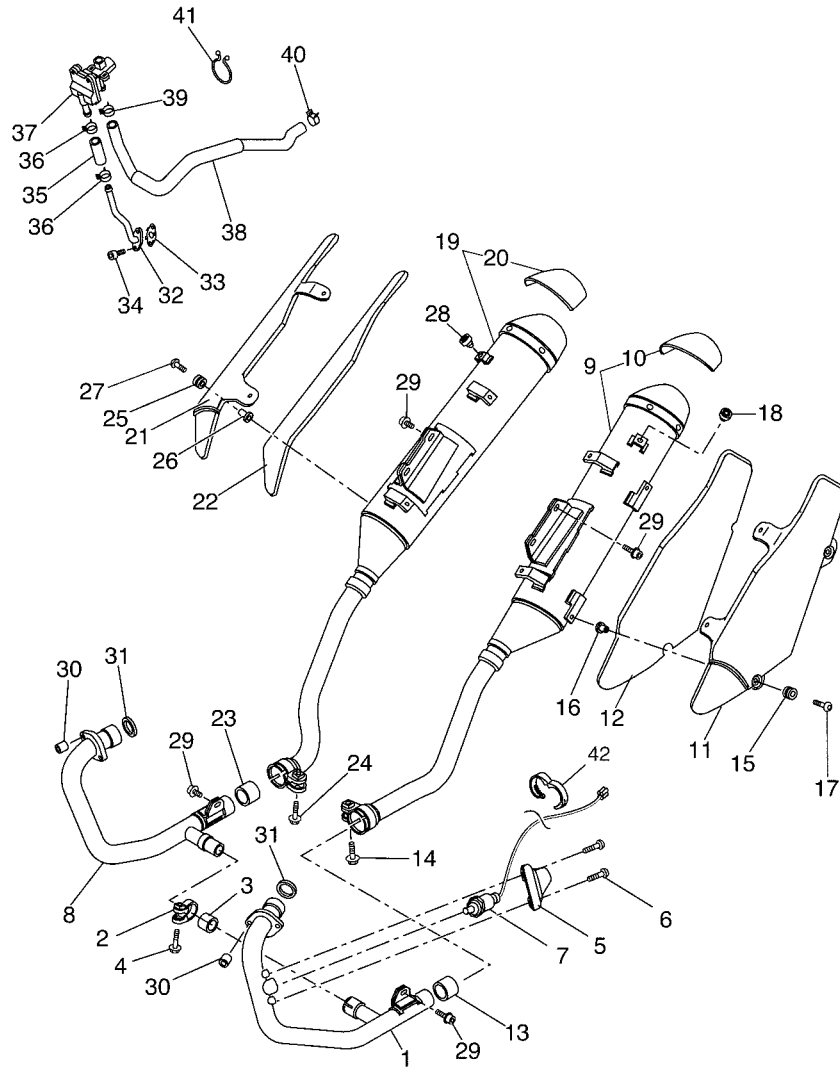
  
5VK1300-C100



5VK8300-F111

FIG. 11 EXHAUST

REF. NO.	PART NO.	DESCRIPTION	01	02	03	04	05	REMARKS
1	5VK-E4611-10	PIPE, EXHAUST 1	1	1	1	1	1	
2	5JX-14725-00	BAND, MUFFLER	1	1	1	1	1	
3	4FU-14714-00	GASKET, MUFFLER	1	1	1	1	1	
4	95814-08035	BOLT, FLANGE	1	1	1	1	1	
5	5VK-E4628-00	PROTECTOR, EXHAUST PIPE	1	1	1	1	1	
6	90111-06060	BOLT, HEX. SOCKET BUTTON	2	2	2	2	2	
7	1B9-8592A-00	SENSOR, OXYGEN	1	1	1	1	1	
8	5VK-E4621-00	PIPE, EXHAUST 2	1	1	1	1	1	
9	5VK-E4711-10	MUFFLER 1	1	1	1	1	1	
10	5VK-W1473-20	.PROTECTOR, MUFFLER 1	1	1	1	1	1	
11	5VK-E4728-30	PROTECTOR, MUFFLER 2	1	1	1	1	1	
12	5VK-E4747-00	DAMPER, MUFFLER	1	1	1	1	1	
13	4EL-14714-00	GASKET, MUFFLER	1	1	1	1	1	
14	95024-08040	BOLT, FLANGE	1	1	1	1	1	
15	90480-12581	GROMMET	4	4	4	4	4	
16	90387-06023	COLLAR	4	4	4	4	4	
17	90149-06280	SCREW	4	4	4	4	4	
18	22W-24181-00	DAMPER, LOCATING 1	1	1	1	1	1	
19	5VK-E4721-10	MUFFLER 2	1	1	1	1	1	
20	5VK-W1473-20	.PROTECTOR, MUFFLER 1	1	1	1	1	1	
21	5VK-E4748-30	PROTECTOR, MUFFLER 4	1	1	1	1	1	
22	5VK-E4757-00	DAMPER, MUFFLER 2	1	1	1	1	1	
23	4EL-14714-00	GASKET, MUFFLER	1	1	1	1	1	
24	95024-08040	BOLT, FLANGE	1	1	1	1	1	
25	90480-12581	GROMMET	4	4	4	4	4	
26	90387-06023	COLLAR	4	4	4	4	4	
27	90149-06280	SCREW	4	4	4	4	4	



FWD  
5VK8300-F111

FIG. 11 EXHAUST

REF. NO.	PART NO.	DESCRIPTION	01	02	03	04	05	REMARKS
28	22W-24181-00	DAMPER, LOCATING 1	1	1	1	1	1	
29	90109-085E2	BOLT	6	6	6	6	6	
30	90179-08442	NUT	4	4	4	4	4	
31	3YF-14613-01	GASKET, EXHAUST PIPE	2	2	2	2	2	
32	5VK-14871-02	PIPE 1	1	1	1	1	1	
33	5VK-14815-00	GASKET	1	1	1	1	1	
34	91380-06016	BOLT	2	2	2	2	2	
35	5VK-14881-00	HOSE, BEND 1	1	1	1	1	1	
36	90467-17089	CLIP	2	2	2	2	2	
37	5VK-14803-00	AIR INDUCTION SYSTEM ASSY	1	1	1	1	1	
38	5VK-E4882-00	HOSE, BEND 2	1	1	1	1	1	
39	90467-17089	CLIP	1	1	1	1	1	
40	90467-170A0	CLIP	1	1	1	1	1	
41	90464-37257	CLAMP	2	2	2	2	2	
42	90464-16001	CLAMP	1	1	1	1	1	

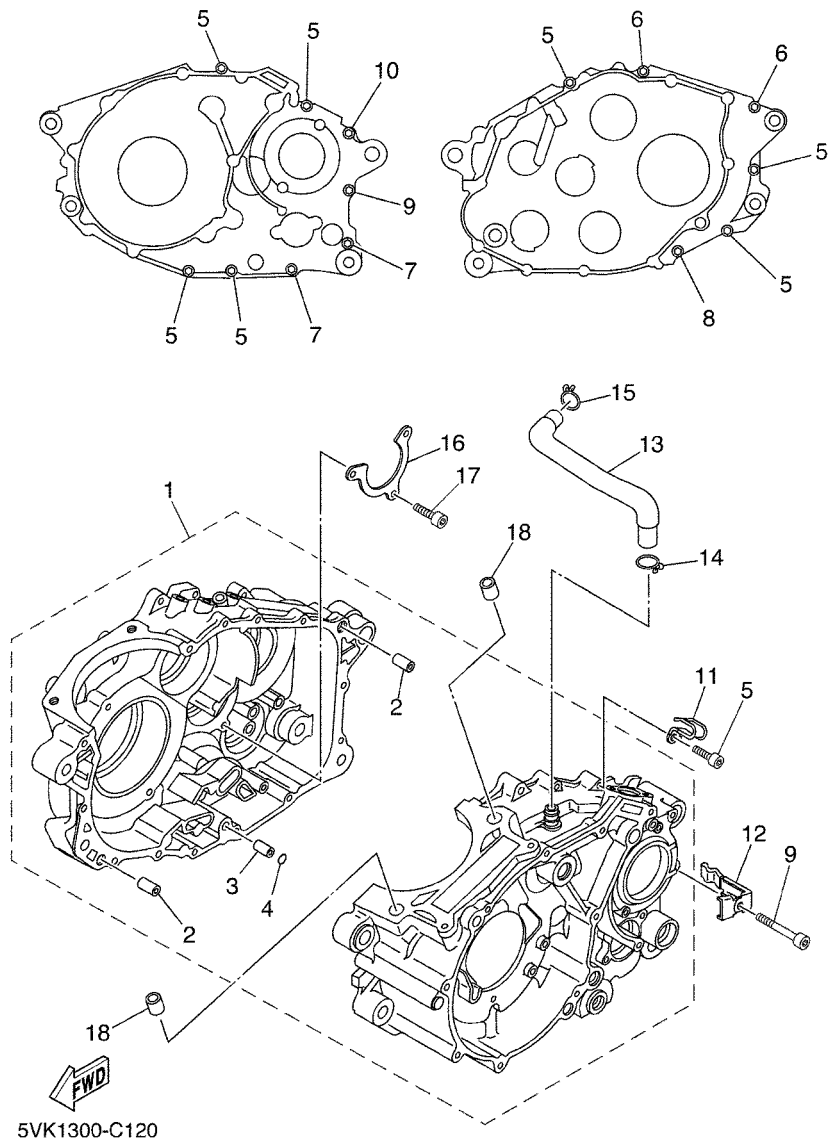


FIG. 12 CRANKCASE

REF. NO.	PART NO.	DESCRIPTION	01	02	03	04	05	REMARKS
1	5VK-E5100-00	CRANKCASE ASSY	1	1	1	1	1	
2	99530-12016	.PIN, DOWEL	2	2	2	2	2	
3	91808-16X00	.PIN, DOWEL	1	1	1	1	1	
4	93210-07X01	.O-RING	1	1	1	1	1	
5	91317-06030	BOLT	7	7	7	7	7	
6	91317-06045	BOLT	2	2	2	2	2	
7	91317-06055	BOLT	2	2	2	2	2	
8	91317-06060	BOLT	1	1	1	1	1	
9	91317-06080	BOLT	1	1	1	1	1	
10	91317-06090	BOLT	1	1	1	1	1	
11	90462-07X00	CLAMP	1	1	1	1	1	
12	90465-12013	CLAMP	1	1	1	1	1	
13	5VK-11166-00	PIPE, BREATHER 1	1	1	1	1	1	
14	90467-14015	CLIP	1	1	1	1	1	
15	90467-14015	CLIP	1	1	1	1	1	
16	5VK-E5383-00	PLATE, BEARING COVER	1	1	1	1	1	
17	91317-06016	BOLT	3	3	3	3	3	
18	99530-14016	PIN, DOWEL	2	2	2	2	2	

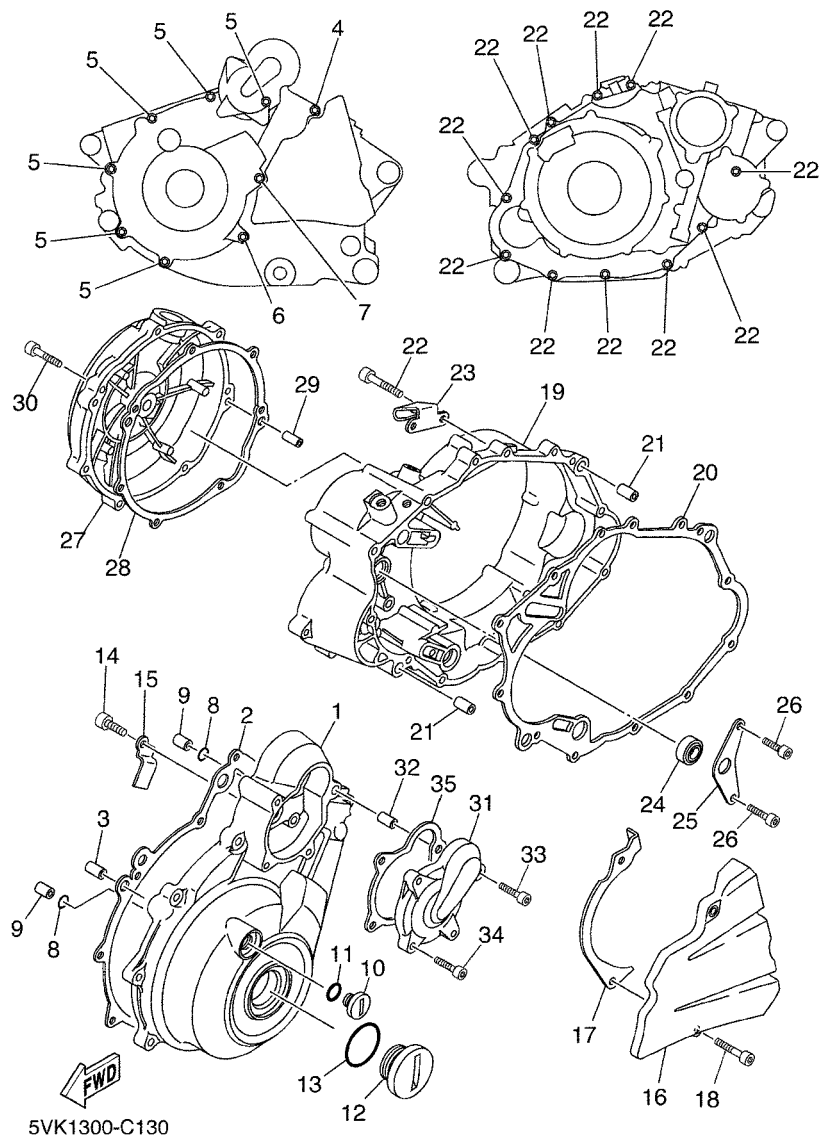
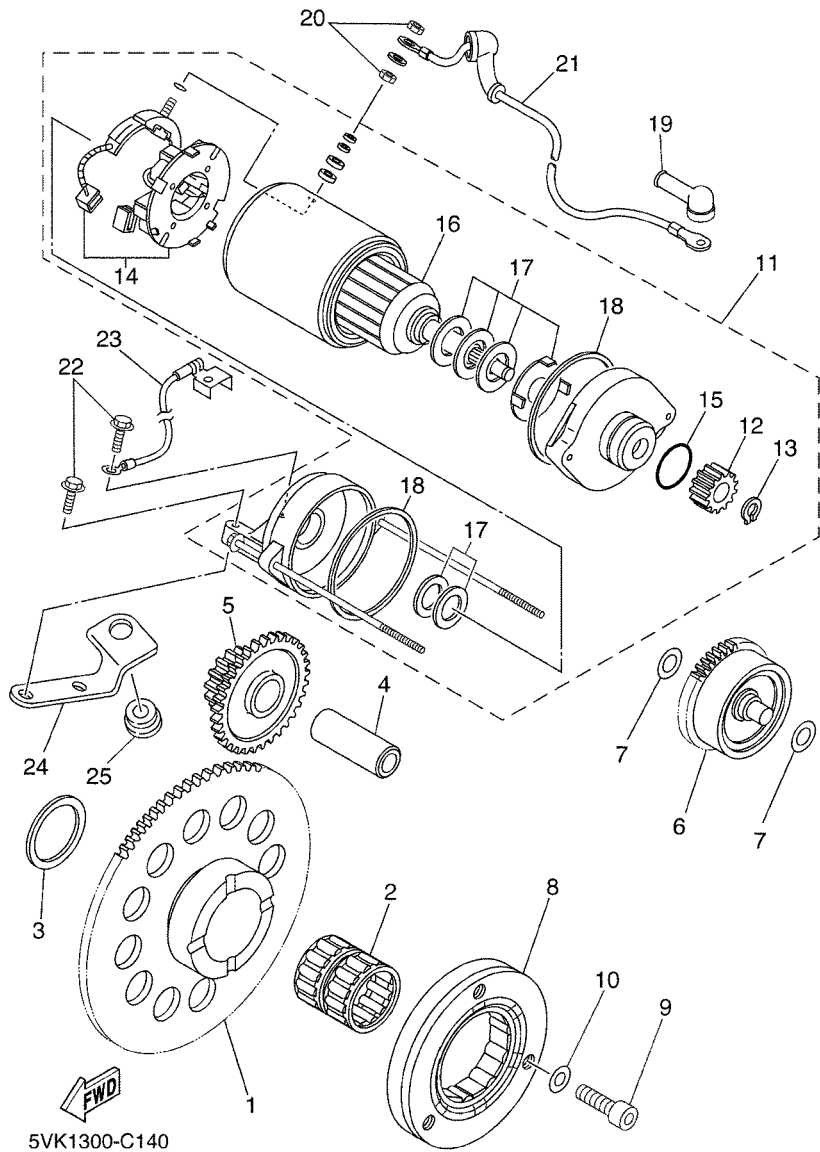


FIG. 13 CRANKCASE COVER 1

REF. NO.	PART NO.	DESCRIPTION	01	02	03	04	05	REMARKS
1	5VK-WE541-00	CRANKCASE COVER ASSY 1	1	1	1	1	1	
2	5VK-E5451-00	GASKET, CRANKCASE COVER 1	1	1	1	1	1	
3	99530-12016	PIN, DOWEL	2	2	2	2	2	
4	91317-06035	BOLT	1	1	1	1	1	
5	91317-06025	BOLT	6	6	6	6	6	
6	91317-06050	BOLT	1	1	1	1	1	
7	91317-06050	BOLT	1	1	1	1	1	
8	93210-13X00	O-RING	2	2	2	2	2	
9	99530-12016	PIN, DOWEL	2	2	2	2	2	
10	90340-14X00	PLUG, STRAIGHT SCREW	1	1	1	1	1	
11	93210-14X00	O-RING	1	1	1	1	1	
12	90340-36X00	PLUG, STRAIGHT SCREW	1	1	1	1	1	
13	93210-35X00	O-RING	1	1	1	1	1	
14	91317-06012	BOLT	1	1	1	1	1	
15	90462-16X00	CLAMP	1	1	1	1	1	
16	5VK-E5421-00	COVER, CRANKCASE 2	1	1	1	1	1	
17	5VK-E7466-00	GUIDE, CHAIN	1	1	1	1	1	
18	91317-06025	BOLT	2	2	2	2	2	
19	5VK-E5431-00	COVER, CRANKCASE 3	1	1	1	1	1	
20	5VK-E5462-00	GASKET, CRANKCASE COVER 3	1	1	1	1	1	
21	99530-12016	PIN, DOWEL	2	2	2	2	2	
22	91317-06030	BOLT	11	11	11	11	11	
23	5VK-E5441-01	HOLDER, CLUTCH CABLE	1	1	1	1	1	
24	93101-14164	OIL SEAL	1	1	1	1	1	
25	5VK-E5118-00	HOLDER	1	1	1	1	1	
26	91317-06012	BOLT	2	2	2	2	2	
27	5VK-E5416-00	COVER, OIL PUMP	1	1	1	1	1	

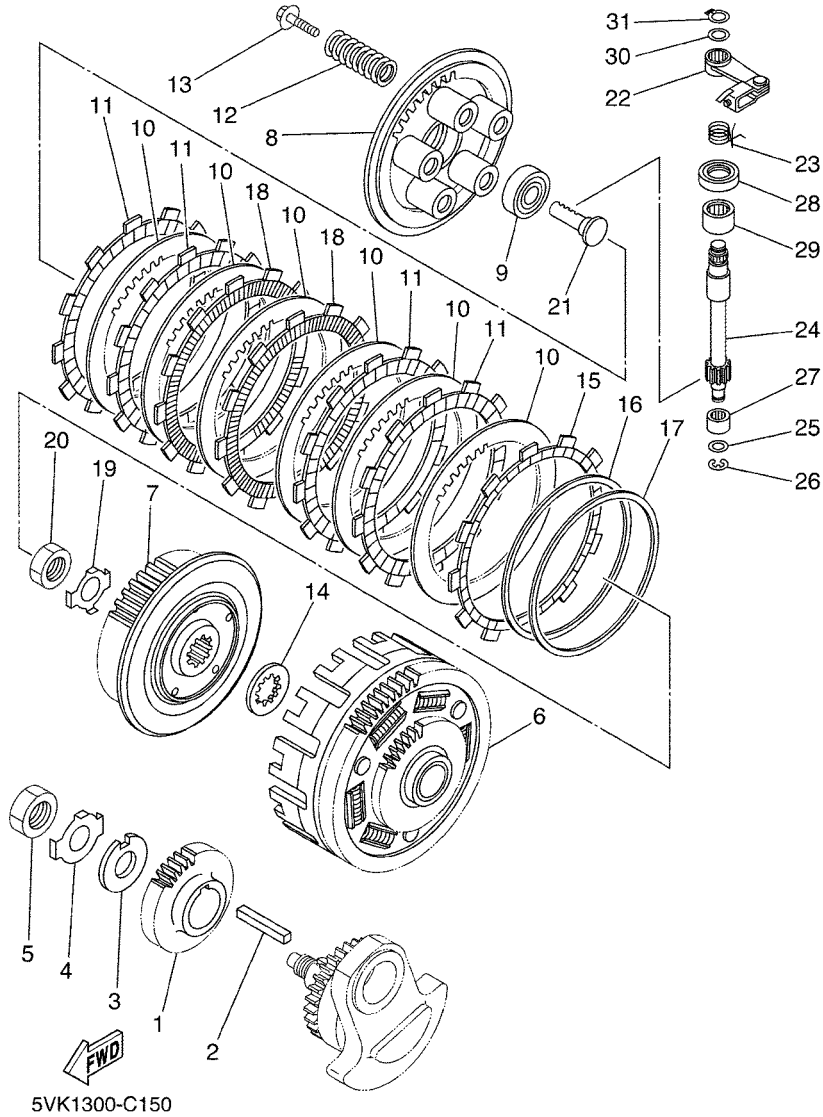


FIG. 14 STARTER CLUTCH



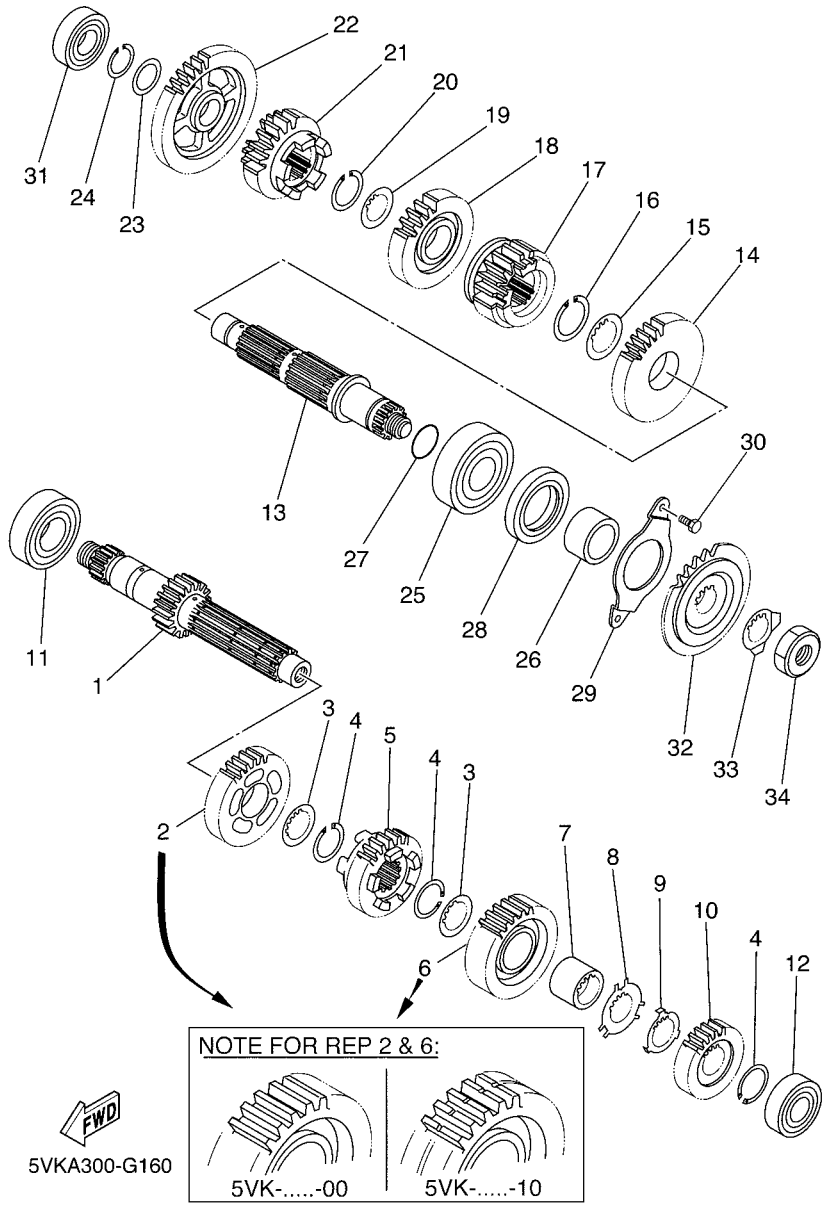
REF. NO.	PART NO.	DESCRIPTION	01	02	03	04	05	REMARKS
1	3YF-15515-00	GEAR 3	1	1	1	1	1	
2	93310-530C7	BEARING	1	1	1	1	1	
3	90201-30X01	WASHER, PLATE	1	1	1	1	1	
4	5VK-E5522-00	SHAFT 2	1	1	1	1	1	
5	5VK-15517-00	GEAR, IDLER 2	1	1	1	1	1	
6	5VK-E5560-00	DAMPER ASSY	1	1	1	1	1	
7	90201-10X18	WASHER, PLATE	2	2	2	2	2	
8	5VK-15590-00	STARTER ONE-WAY ASSY	1	1	1	1	1	
9	91317-08025	BOLT	3	3	3	3	3	
10	90201-08X18	WASHER, PLATE	3	3	3	3	3	
11	3SX-81890-00	MOTOR ASSY	1	1	1	1	1	
12	1VJ-15511-00	.GEAR, STARTING MOTOR	1	1	1	1	1	
13	93440-11024	.CIRCLIP	1	1	1	1	1	
14	3AJ-81801-00	.BRUSH SET	1	1	1	1	1	
15	1FK-81847-00	.O-RING	1	1	1	1	1	
16	3AJ-81850-00	.ARMATURE ASSY	1	1	1	1	1	
17	3AJ-81809-00	.WASHER KIT	1	1	1	1	1	
18	11H-81844-00	.GASKET	2	2	2	2	2	
19	4G0-81871-00	CAP	1	1	1	1	1	
20	4XV-8182A-00	NUT	2	2	2	2	2	
21	5VK-81815-00	CORD, STARTER MOTOR	1	1	1	1	1	
22	95817-06035	BOLT, FLANGE	2	2	2	2	2	
23	5VK-H2116-00	WIRE, MINUS LEAD	1	1	1	1	1	
24	5VK-E5199-00	BRACKET	1	1	1	1	1	
25	90480-13398	GROMMET	1	1	1	1	1	

FIG. 15 CLUTCH



REF. NO.	PART NO.	DESCRIPTION	01	02	03	04	05	REMARKS
1	5VK-E6111-00	GEAR, PRIMARY DRIVE	1	1	1	1	1	
2	90282-07001	KEY, STRAIGHT	1	1	1	1	1	
3	90209-20012	WASHER	1	1	1	1	1	
4	90215-20X00	WASHER, LOCK	1	1	1	1	1	
5	90170-20274	NUT	1	1	1	1	1	
6	5VK-E6150-00	PRIMARY DRIVEN GEAR COMP.	1	1	1	1	1	
7	5VK-16371-00	BOSS, CLUTCH	1	1	1	1	1	
8	5VK-16351-00	PLATE, PRESSURE 1	1	1	1	1	1	
9	93306-00304	BEARING	1	1	1	1	1	
10	4X7-16325-00	PLATE, CLUTCH 2	6	6	6	6	6	
11	22U-16321-00	PLATE, FRICTION	4	4	4	4	4	
12	90501-260A1	SPRING, COMPRESSION	5	5	5	5	5	
13	90119-06105	BOLT, WITH WASHER	5	5	5	5	5	
14	2JN-16154-00	PLATE, THRUST 1	1	1	1	1	1	
15	5VK-16331-00	PLATE, FRICTION 2	1	1	1	1	1	
16	5JG-16383-00	SPRING, CLUTCH BOSS	1	1	1	1	1	
17	5JG-16384-00	PLATE, SEAT	1	1	1	1	1	
18	5TA-16321-00	PLATE, FRICTION	2	2	2	2	2	
19	90215-20X01	WASHER, LOCK	1	1	1	1	1	
20	90170-20327	NUT	1	1	1	1	1	
21	4XV-16356-01	ROD, PUSH 1	1	1	1	1	1	
22	5VK-16340-00	PUSH LEVER ASSY	1	1	1	1	1	
23	90508-16X00	SPRING, TORSION	1	1	1	1	1	
24	5VK-E6382-00	AXLE, PUSH LEVER	1	1	1	1	1	
25	90201-08X19	WASHER, PLATE	1	1	1	1	1	
26	99001-07600	CIRCLIP	1	1	1	1	1	
27	93317-11020	BEARING	1	1	1	1	1	

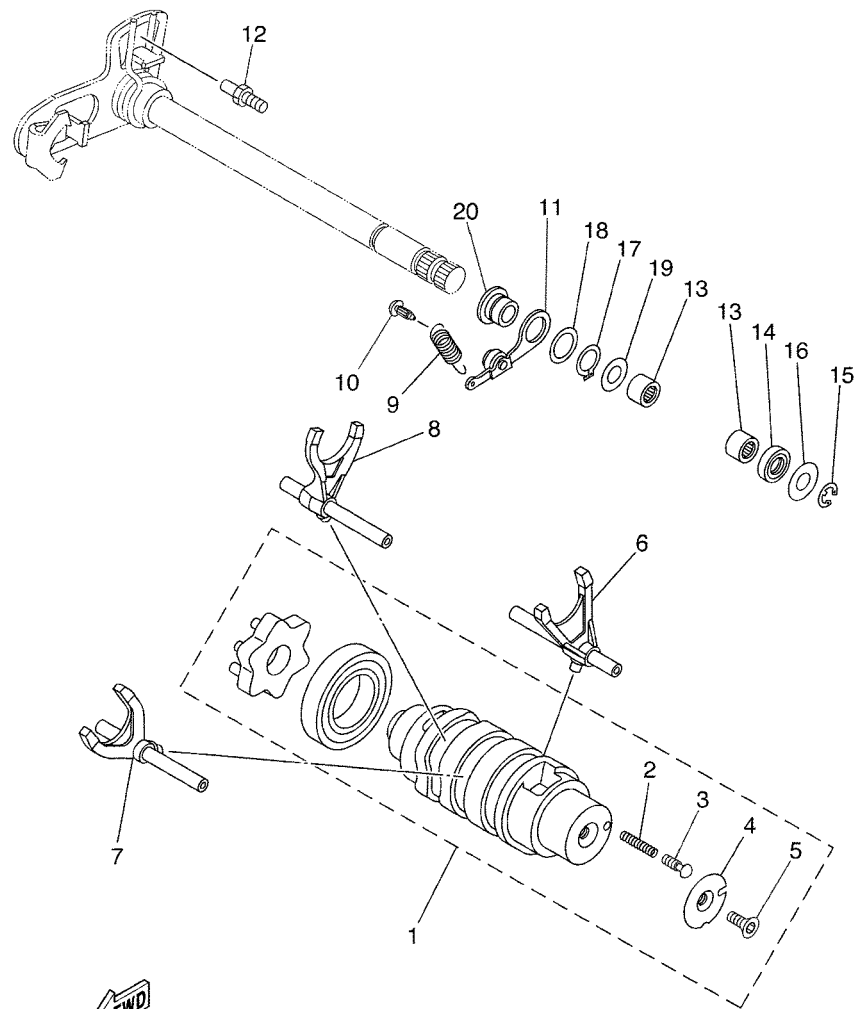




**FIG. 16 TRANSMISSION**

REF. NO.	PART NO.	DESCRIPTION	01	02	03	04	05	REMARKS
1	5VK-E7401-00	MAIN AXLE ASSY(12T)	1	1	1	1	1	
2	5VK-E7141-00	GEAR, 4TH PINION (22T)	1	1	1	1	1	AP
	5VK-E7141-10	GEAR, 4TH PINION (22T)	1	1	1	1	1	AP
3	90209-21X00	WASHER	2	2	2	2	2	
4	93440-25084	CIRCLIP	3	3	3	3	3	
5	5VK-E7131-00	GEAR, 3RD PINION (20T)	1	1	1	1	1	
6	5VK-E7151-00	GEAR, 5TH PINION (26T)	1	1	1	1	1	AP
	5VK-E7151-10	GEAR, 5TH PINION (26T)	1	1	1	1	1	AP
7	90387-21002	COLLAR	1	1	1	1	1	
8	90209-22X00	WASHER	1	1	1	1	1	
9	90209-21351	WASHER	1	1	1	1	1	
10	5VK-E7121-00	GEAR, 2ND PINION (16T)	1	1	1	1	1	
11	93306-205XA	BEARING	1	1	1	1	1	
12	93306-004XL	BEARING	1	1	1	1	1	
13	5VK-E7402-00	DRIVE AXLE ASSY	1	1	1	1	1	
14	5VK-E7221-00	GEAR, 2ND WHEEL (26T)	1	1	1	1	1	
15	90209-26348	WASHER	1	1	1	1	1	
16	93440-28062	CIRCLIP	1	1	1	1	1	
17	5VK-E7251-00	GEAR, 5TH WHEEL (20T)	1	1	1	1	1	
18	5VK-E7231-00	GEAR, 3RD WHEEL (23T)	1	1	1	1	1	
19	90209-21X00	WASHER	1	1	1	1	1	
20	93440-25084	CIRCLIP	1	1	1	1	1	
21	5VK-E7241-00	GEAR, 4TH WHEEL (20T)	1	1	1	1	1	
22	5VK-E7211-00	GEAR, 1ST WHEEL (30T)	1	1	1	1	1	
23	90201-208G4	WASHER, PLATE	1	1	1	1	1	
24	93410-20825	CIRCLIP	1	1	1	1	1	
25	93306-305X4	BEARING	1	1	1	1	1	





5VK1300-C170

FIG. 17 SHIFT CAM & FORK

REF. NO.	PART NO.	DESCRIPTION	01	02	03	04	05	REMARKS
1	5VK-18540-00	SHIFT CAM ASSY	1	1	1	1	1	
2	90501-06022	.SPRING, COMPRESSION	1	1	1	1	1	
3	4UN-18542-00	.POINT, NEUTRAL	1	1	1	1	1	
4	4UN-18566-00	.PLATE, SIDE 2	1	1	1	1	1	
5	90149-05321	.SCREW	1	1	1	1	1	
6	5VK-E8501-00	FORK, SHIFT 1	1	1	1	1	1	
7	5VK-E8502-00	FORK, SHIFT 2	1	1	1	1	1	
8	5VK-E8503-00	FORK, SHIFT 3	1	1	1	1	1	
9	5VK-E8144-00	HANGER, SPRING	1	1	1	1	1	
10	132-16346-00	HOOK, SPRING	1	1	1	1	1	
11	5JW-18140-00	STOPPER LEVER ASSY	1	1	1	1	1	
12	5VK-18127-00	STOPPER, SCREW	1	1	1	1	1	
13	93315-11206	BEARING	2	2	2	2	2	
14	93102-12106	OIL SEAL (SD 12-22-5 HS)	1	1	1	1	1	
15	99001-10600	CIRCLIP	1	1	1	1	1	
16	90201-12X06	WASHER, PLATE	1	1	1	1	1	
17	93410-17X00	CIRCLIP	1	1	1	1	1	
18	90201-17X01	WASHER, PLATE	1	1	1	1	1	
19	90201-12X05	WASHER, PLATE	1	1	1	1	1	
20	5VK-E8699-00	BOSS 1	1	1	1	1	1	



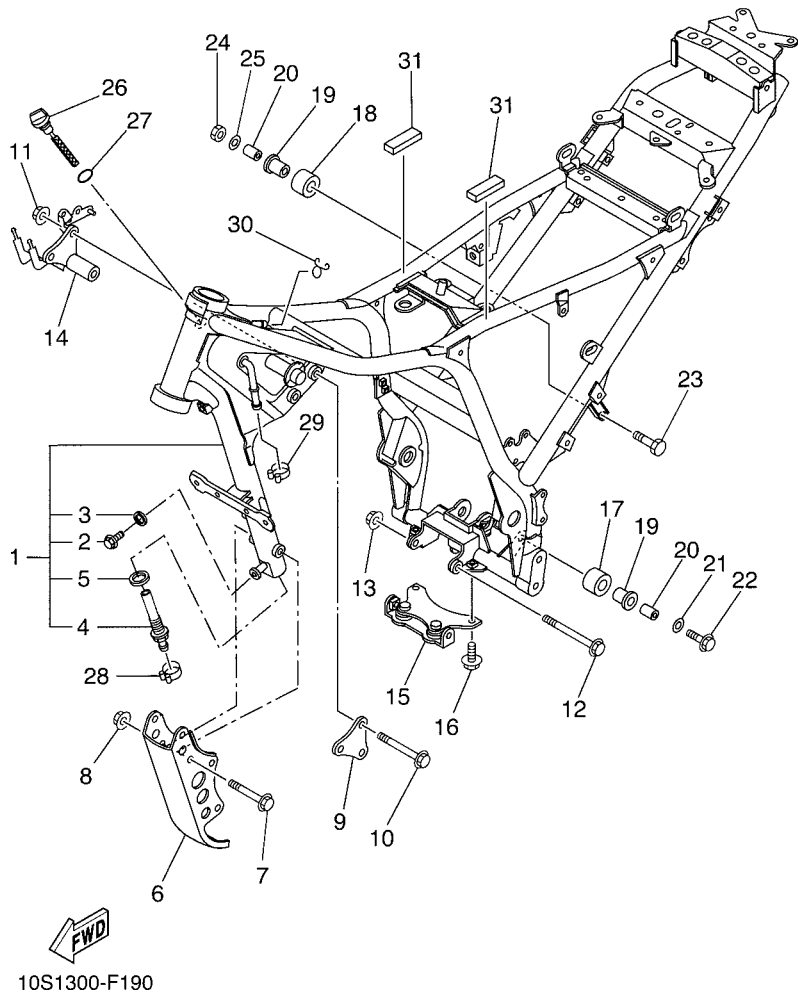
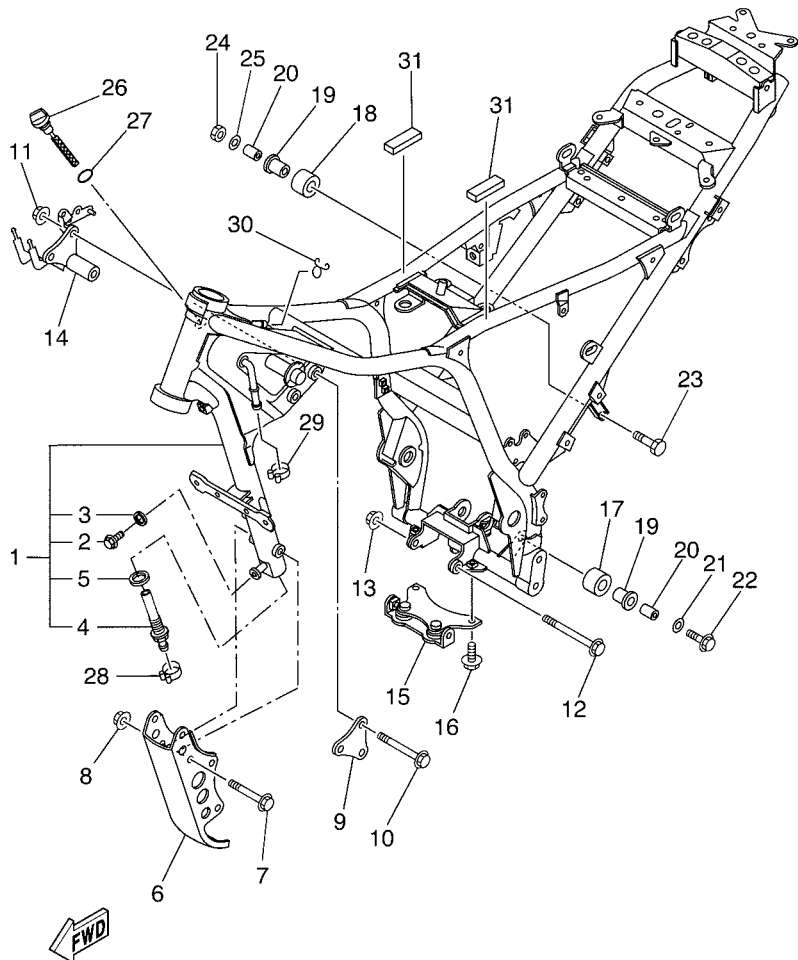


FIG. 19 FRAME

REF. NO.	PART NO.	DESCRIPTION	01	02	03	04	05	REMARKS
1	5VK-F1110-10	FRAME COMP.	1	1	1	1	1	
2	95807-08012	.BOLT, FLANGE	1	1	1	1	1	
3	90430-08119	.GASKET	1	1	1	1	1	
4	5VK-F1756-00	.NET, FILTER	1	1	1	1	1	
5	90430-22123	.GASKET	1	1	1	1	1	
6	5VK-F1316-00	STAY, ENGINE 3	1	1	1	1	1	
7	95814-10070	BOLT, FLANGE	4	4	4	4	4	
8	90179-10658	NUT	4	4	4	4	4	
9	5VK-F1315-00	STAY, ENGINE 2	1	1	1	1	1	
10	95814-10100	BOLT, FLANGE	3	3	3	3	3	
11	90179-10658	NUT	3	3	3	3	3	
12	90105-10040	BOLT, WASHER BASED	1	1	1	1	1	
13	90179-10658	NUT	1	1	1	1	1	
14	5VK-F1410-00	ENGINE BRACKET COMP.	1	1	1	1	1	
15	5VK-21445-00	STAY, MUFFLER 1	1	1	1	1	1	
16	95024-08016	BOLT, FLANGE	2	2	2	2	2	
17	30X-22178-00	TENSIONER	1	1	1	1	1	
18	10V-22178-00	TENSIONER	1	1	1	1	1	
19	10V-22184-00	BUSH	2	2	2	2	2	
20	90387-08024	COLLAR	2	2	2	2	2	
21	90201-082H0	WASHER, PLATE	1	1	1	1	1	
22	95827-08040	BOLT, FLANGE	1	1	1	1	1	
23	90101-08428	BOLT	1	1	1	1	1	
24	95607-08100	NUT, U	1	1	1	1	1	
25	92907-08200	WASHER	1	1	1	1	1	
26	5VK-15362-00	PLUG, OIL LEVEL	1	1	1	1	1	
27	93210-19123	O-RING	1	1	1	1	1	

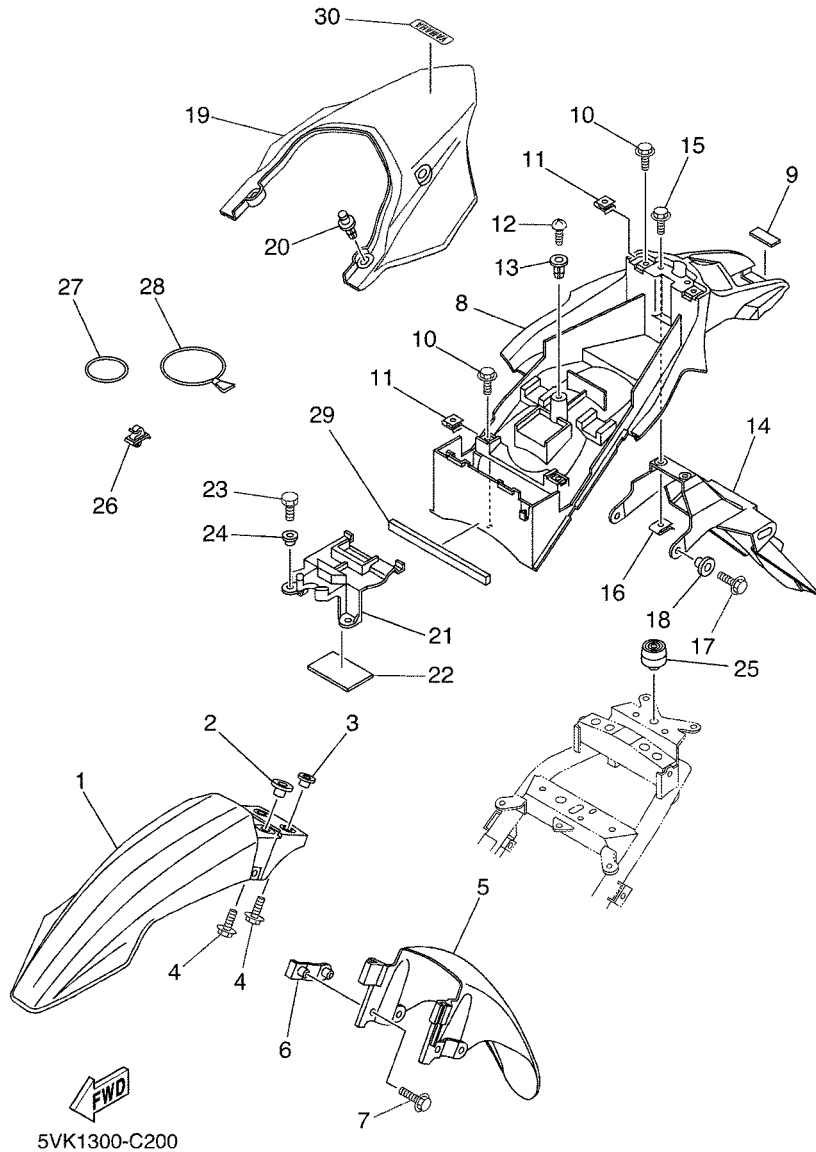
FIG. 19 FRAME

REF. NO.	PART NO.	DESCRIPTION	01	02	03	04	05	REMARKS
28	90467-19800	CLIP	1	1	1	1	1	
29	90467-17800	CLIP	1	1	1	1	1	
30	90467-10008	CLIP	1	1	1	1	1	
31	5VK-21746-00	DAMPER	2	2	2	2	2	
-----								
-----								
-----								
-----								
-----								
-----								
-----								
-----								
-----								
-----								



10S1300-F190

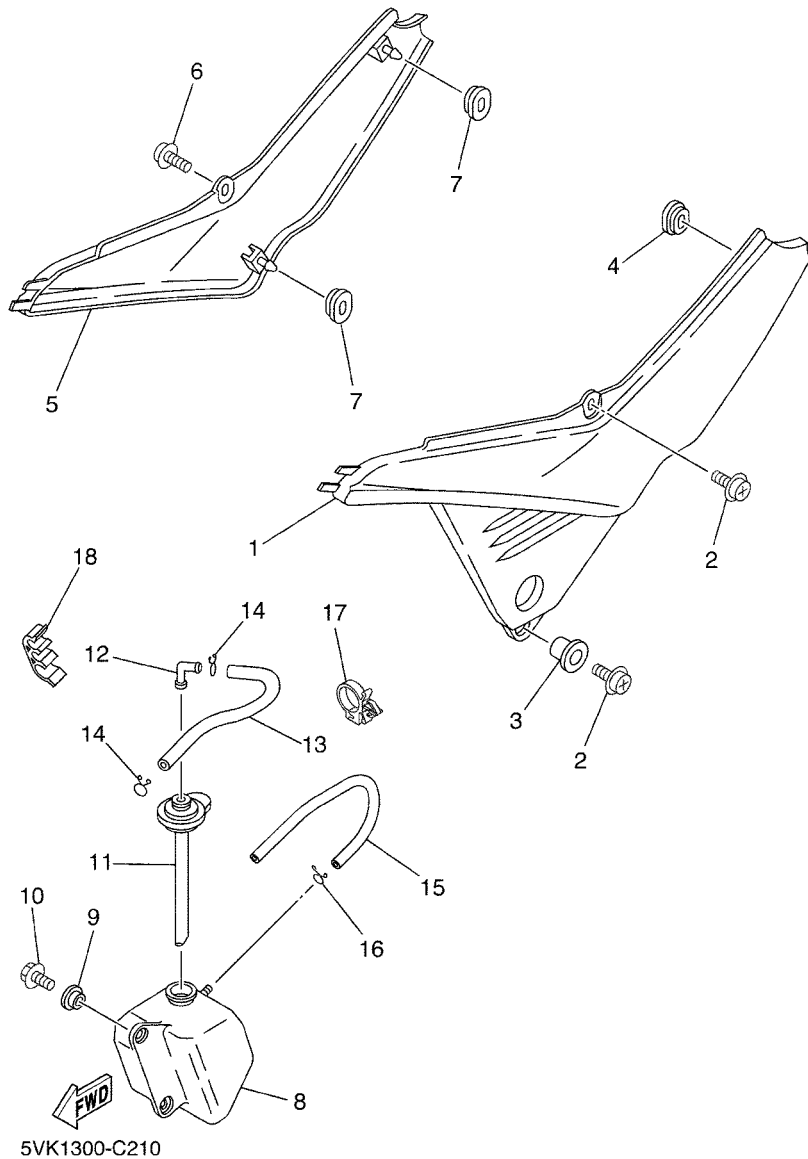
FIG. 20 FENDER



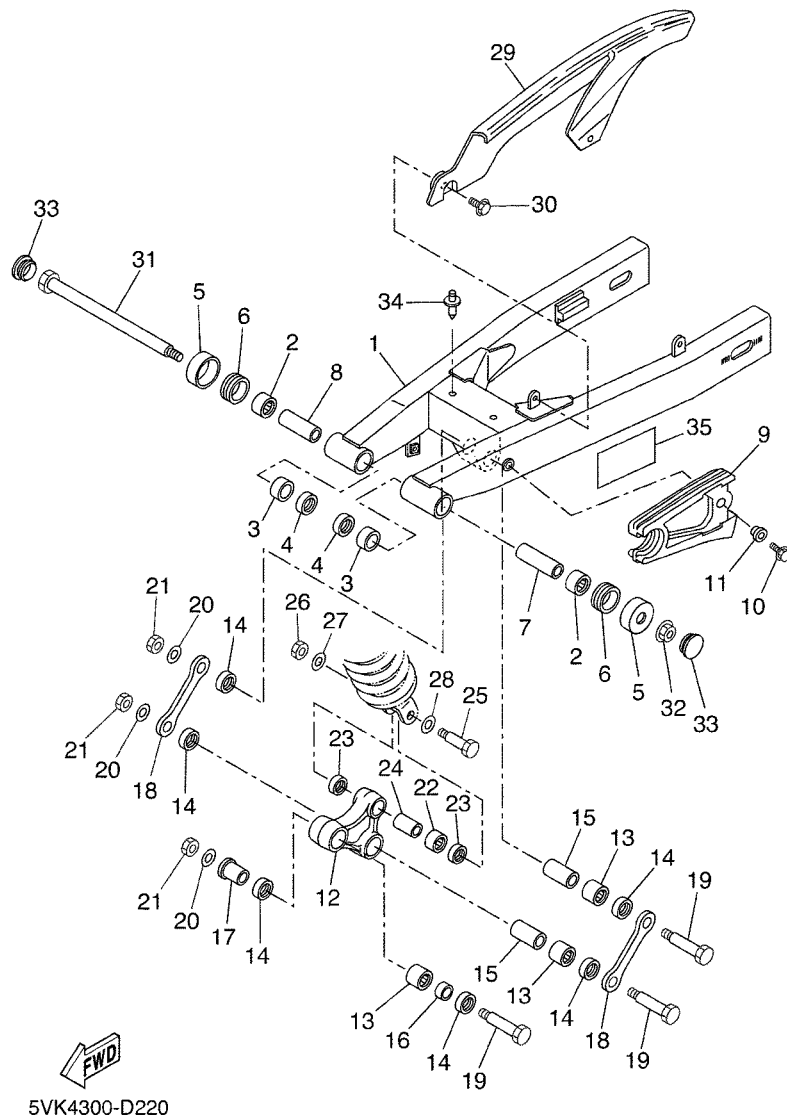
REF. NO.	PART NO.	DESCRIPTION	01	02	03	04	05	REMARKS
1	5VK-F1511-00	FENDER, FRONT	1	1	1	1	1	UR FOR DPBSE (DPB)
	5VK-F1511-10	FENDER, FRONT	1	1	1	1	1	UR FOR YB (DNMD)
2	90387-065X7	COLLAR	2	2	2	2	2	
3	90387-087L0	COLLAR	2	2	2	2	2	
4	90119-06096	BOLT, WITH WASHER	4	4	4	4	4	
5	5VK-F1556-00	FENDER, FRONT 2	1	1	1	1	1	
6	5VK-F1587-00	STAY 1	2	2	2	2	2	
7	90119-06051	BOLT, WITH WASHER	4	4	4	4	4	
8	5VK-F1611-01	FENDER, REAR	1	1	1	1	1	
9	5DM-28371-00	DAMPER	1	1	1	1	1	
10	95807-06012	BOLT, FLANGE	4	4	4	4	4	
11	90183-06023	NUT, SPRING	4	4	4	4	4	
12	97707-60020	SCREW, TAPPING	1	1	1	1	1	
13	90338-08226	PLUG	1	1	1	1	1	
14	5VK-F1685-00	BRACKET, LICENSE	1	1	1	1	1	
15	90119-06118	BOLT, WITH WASHER	2	2	2	2	2	
16	90183-06023	NUT, SPRING	2	2	2	2	2	
17	95807-06014	BOLT, FLANGE	2	2	2	2	2	
18	90387-06648	COLLAR	2	2	2	2	2	
19	5VK-F1651-00	COVER, REAR FENDER	1	1	1	1	1	UR FOR DPBSE (DPB)
	5VK-F1651-10	COVER, REAR FENDER	1	1	1	1	1	UR FOR YB (YB)
20	90269-08066	RIVET	2	2	2	2	2	
21	5VK-F160E-00	BOX	1	1	1	1	1	
22	5VK-21639-00	DAMPER 2	1	1	1	1	1	
23	97007-05012	BOLT	2	2	2	2	2	
24	90387-05803	COLLAR	2	2	2	2	2	
25	1T4-24741-00	PAD, SEAT	1	1	1	1	1	



FIG. 21 SIDE COVER



REF. NO.	PART NO.	DESCRIPTION	01	02	03	04	05	REMARKS
1	5VK-F1711-00	COVER, SIDE 1	1	1	1	1	1	
2	90159-06078	SCREW, WITH WASHER	2	2	2	2	2	
3	90387-07717	COLLAR	1	1	1	1	1	
4	90480-01558	GROMMET	1	1	1	1	1	
5	5VK-F1721-00	COVER, SIDE 2	1	1	1	1	1	
6	90159-06078	SCREW, WITH WASHER	1	1	1	1	1	
7	90480-01558	GROMMET	2	2	2	2	2	
8	5VK-F1871-00	TANK, RECOVERY	1	1	1	1	1	
9	90387-062M9	COLLAR	2	2	2	2	2	
10	95807-06012	BOLT, FLANGE	2	2	2	2	2	
11	5VK-21875-00	CAP	1	1	1	1	1	
12	26H-21828-00	ELBOW	1	1	1	1	1	
13	90445-08020	HOSE	1	1	1	1	1	
14	90467-08003	CLIP	2	2	2	2	2	
15	90445-08008	HOSE	1	1	1	1	1	
16	90467-08003	CLIP	1	1	1	1	1	
17	90464-16006	CLAMP	1	1	1	1	1	
18	90464-11008	CLAMP	1	1	1	1	1	



5VK4300-D220

FIG. 22 REAR ARM

REF. NO.	PART NO.	DESCRIPTION	01	02	03	04	05	REMARKS
1	5VK-F2110-10	REAR ARM COMP.	1	1	1	1	1	
2	93315-22251	BEARING	2	2	2	2	2	
3	90380-22111	BUSH, SOLID	2	2	2	2	2	
4	93106-22019	OIL SEAL (DC 22-28-8)	2	2	2	2	2	
5	30X-2219X-00	COVER	2	2	2	2	2	
6	93108-35004	OIL SEAL (35-41-8)	2	2	2	2	2	
7	5VK-22124-00	BUSH 2	1	1	1	1	1	
8	5VK-22123-00	BUSH 1	1	1	1	1	1	
9	5VK-F2151-00	SEAL, GUARD	1	1	1	1	1	
10	95807-06020	BOLT, FLANGE	1	1	1	1	1	
11	90387-06066	COLLAR	1	1	1	1	1	
12	5VK-F217A-00	ARM, RELAY	1	1	1	1	1	
13	93315-32053	BEARING	3	3	3	3	3	
14	93109-20076	OIL SEAL	6	6	6	6	6	
15	90387-167R5	COLLAR	2	2	2	2	2	
16	90387-16011	COLLAR	1	1	1	1	1	
17	90387-16012	COLLAR	1	1	1	1	1	
18	5VK-F217F-00	ROD, CONNECTING 1	2	2	2	2	2	
19	5VK-22125-00	BOLT	3	3	3	3	3	
20	90201-160F6	WASHER, PLATE	3	3	3	3	3	
21	90185-14002	NUT, SELF-LOCKING	3	3	3	3	3	
22	93315-31759	BEARING	1	1	1	1	1	
23	93109-17071	OIL SEAL	2	2	2	2	2	
24	90387-127W0	COLLAR	1	1	1	1	1	
25	90101-10659	BOLT	1	1	1	1	1	
26	95614-10100	NUT, U	1	1	1	1	1	
27	90201-101J1	WASHER, PLATE	1	1	1	1	1	





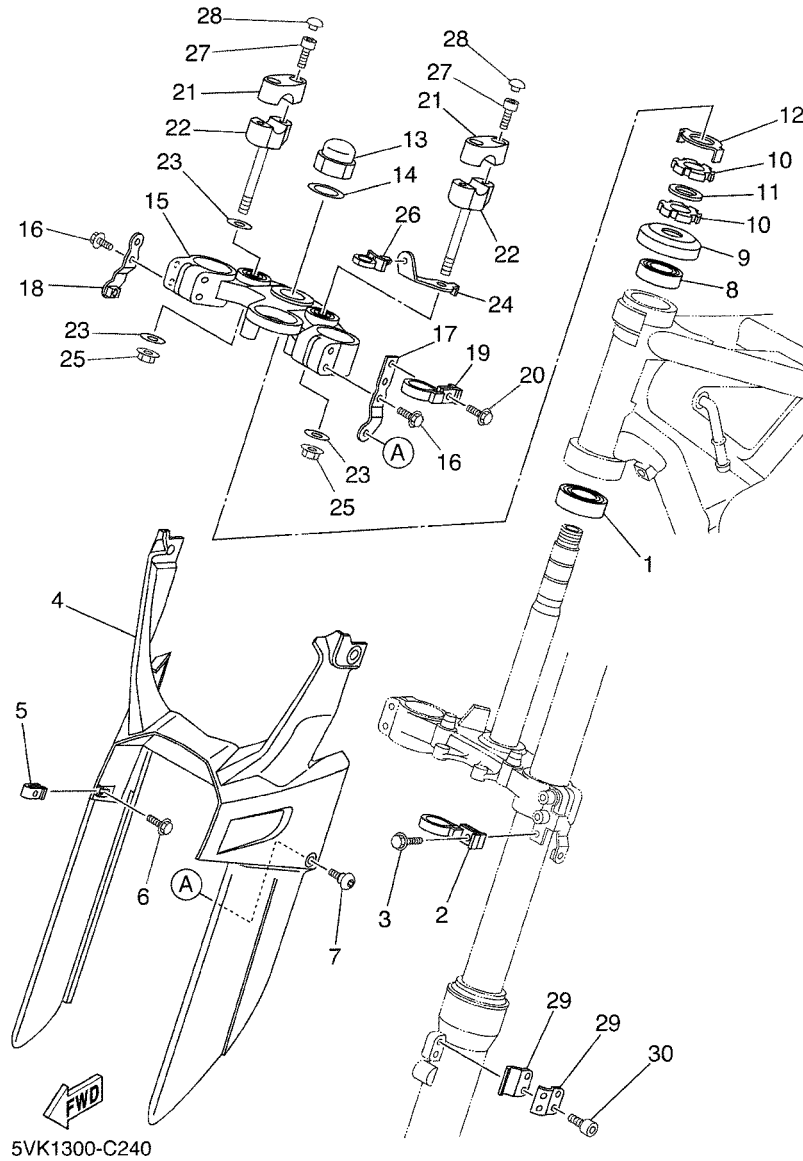


FIG. 24 STEERING

REF. NO.	PART NO.	DESCRIPTION	01	02	03	04	05	REMARKS
1	93332-000Y5	BEARING	1	1	1	1	1	
2	5VK-23389-00	GUIDE, CABLE	1	1	1	1	1	
3	90105-05361	BOLT, FLANGE	1	1	1	1	1	
4	5VK-F3472-00	PROTECTOR	1	1	1	1	1	
5	90183-05061	NUT, SPRING	2	2	2	2	2	
6	90119-05193	BOLT, WITH WASHER	2	2	2	2	2	
7	90111-05011	BOLT, HEX. SOCKET BUTTON	2	2	2	2	2	
8	93332-000Y6	BEARING	1	1	1	1	1	
9	1W1-23416-00	COVER, BALL RACE 2	1	1	1	1	1	
10	90179-25615	NUT	2	2	2	2	2	
11	90202-26142	WASHER, PLATE	1	1	1	1	1	
12	3YF-23418-00	WASHER, SPECIAL	1	1	1	1	1	
13	90176-22081	NUT, CROWN	1	1	1	1	1	
14	90201-220T0	WASHER, PLATE	1	1	1	1	1	
15	5VK-23430-00	HANDLE CROWN COMP.	1	1	1	1	1	
16	95027-08040	BOLT, FLANGE	4	4	4	4	4	
17	5VK-F317E-00	STAY	1	1	1	1	1	
18	5VK-F317F-00	STAY 2	1	1	1	1	1	
19	5VK-23389-00	GUIDE, CABLE	1	1	1	1	1	
20	90105-05361	BOLT, FLANGE	1	1	1	1	1	
21	4H7-23441-01-P5	HOLDER, HANDLE UPPER	2	2	2	2	2	S8 FOR DPBSE, YB
22	3Y6-23442-00-P1	HOLDER, HANDLE LOWER	2	2	2	2	2	S8 FOR DPBSE, YB
23	90201-10141	WASHER, PLATE	3	3	3	3	3	
24	5VK-F317M-00	STAY 3	1	1	1	1	1	
25	95607-10200	NUT, U FLANGE	2	2	2	2	2	
26	90464-12001	CLAMP	1	1	1	1	1	
27	91317-08030	BOLT	4	4	4	4	4	



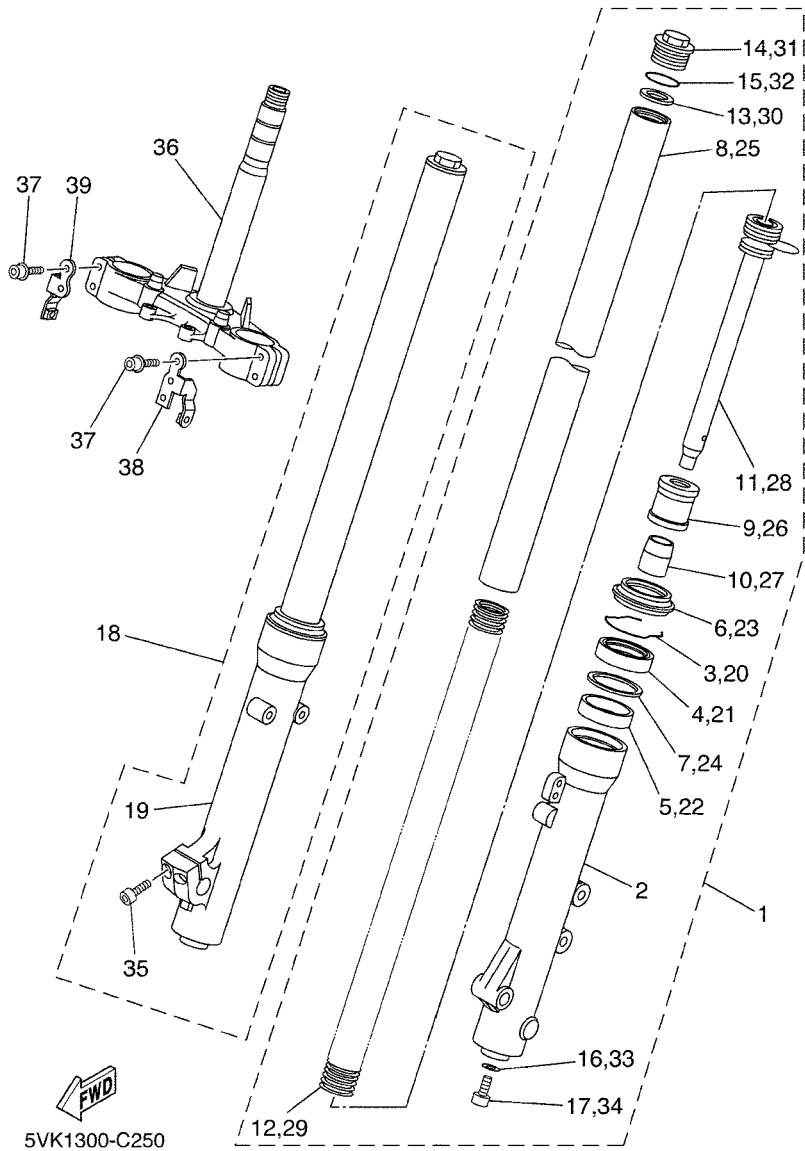
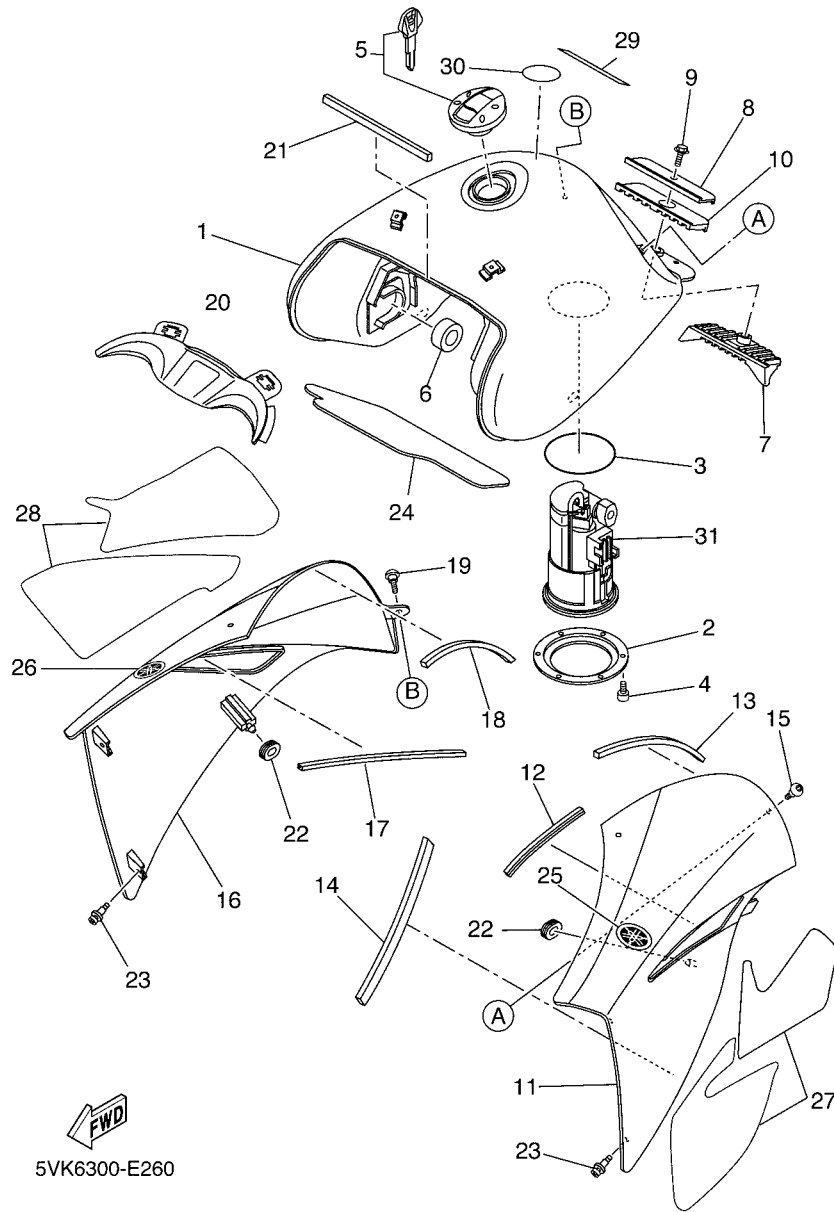


FIG. 25 FRONT FORK

REF. NO.	PART NO.	DESCRIPTION	01	02	03	04	05	REMARKS
1	5VK-F3102-10	FRONT FORK ASSY (L.H)	1	1	1	1	1	(PAIOLI - MATT BL
2	5VK-F3126-10	.TUBE, OUTER (LEFT)	1	1	1	1	1	(PAIOLI - MATT BL
3	5VK-F3153-00	.RING, SNAP	1	1	1	1	1	(PAIOLI)
4	4DA-23145-L0	.OIL SEAL	1	1	1	1	1	
5	5VK-F3125-00	.METAL, SLIDE 1	1	1	1	1	1	(PAIOLI)
6	5VK-F3144-00	.SEAL, DUST	1	1	1	1	1	(PAIOLI)
7	5VK-F3146-00	.WASHER, OIL SEAL	1	1	1	1	1	(PAIOLI)
8	5VK-F3110-00	.INNER TUBE COMP:1	1	1	1	1	1	(PAIOLI)
9	3XJ-23171-L0	.PISTON, FRONT FORK	1	1	1	1	1	
10	5VK-F3173-00	.SPINDLE, TAPER	1	1	1	1	1	(PAIOLI)
11	5VK-F3170-00	.CYLINDER COMP., FRONT FORK	1	1	1	1	1	(PAIOLI)
12	5VK-F3141-00	.SPRING, FRONT FORK	1	1	1	1	1	(PAIOLI)
13	5VK-F3149-00	.WASHER, SPRING UPPER	1	1	1	1	1	(PAIOLI)
14	5VK-F3111-00	.BOLT, CAP	1	1	1	1	1	(PAIOLI)
15	4V4-23188-L0	.O-RING	1	1	1	1	1	
16	5JH-F3158-00	.GASKET	1	1	1	1	1	(PAIOLI)
17	5VK-F3181-00	.BOLT, HEXAGON SOCKET HEAD	1	1	1	1	1	(PAIOLI)
18	5VK-F3103-10	FRONT FORK ASSY (R.H)	1	1	1	1	1	(PAIOLI - MATT BL
19	5VK-F3136-10	.TUBE, OUTER (RIGHT)	1	1	1	1	1	(PAIOLI - MATT BL
20	5VK-F3153-00	.RING, SNAP	1	1	1	1	1	(PAIOLI)
21	4DA-23145-L0	.OIL SEAL	1	1	1	1	1	
22	5VK-F3125-00	.METAL, SLIDE 1	1	1	1	1	1	(PAIOLI)
23	5VK-F3144-00	.SEAL, DUST	1	1	1	1	1	(PAIOLI)
24	5VK-F3146-00	.WASHER, OIL SEAL	1	1	1	1	1	(PAIOLI)
25	5VK-F3110-00	.INNER TUBE COMP:1	1	1	1	1	1	(PAIOLI)
26	3XJ-23171-L0	.PISTON, FRONT FORK	1	1	1	1	1	
27	5VK-F3173-00	.SPINDLE, TAPER	1	1	1	1	1	(PAIOLI)





5VK6300-E260

FIG. 26 FUEL TANK

REF. NO.	PART NO.	DESCRIPTION	01	02	03	04	05	REMARKS
1	5VK-F4110-10-P0	FUEL TANK COMP.	1	1	1	1	1	MBL2 FOR DPBSE,YB
2	5VK-F4491-00	BRACKET, FUEL PUMP	1	1	1	1	1	
3	5JW-24486-00	O-RING	1	1	1	1	1	
4	91317-05010	BOLT	6	6	6	6	6	
5	5VK-24602-00	CAP ASSY	1	1	1	1	1	
6	3TB-24181-00	DAMPER, LOCATING 1	2	2	2	2	2	
7	5VK-24182-00	DAMPER, LOCATING 2	1	1	1	1	1	
8	5VK-F4186-00	WASHER, SPECIAL	1	1	1	1	1	
9	95827-06012	BOLT, FLANGE	1	1	1	1	1	
10	5VK-24183-00	DAMPER, LOCATING 3	1	1	1	1	1	
11	5VK-F137W-01	SCOOP, AIR 1	1	1	1	1	1	UR FOR DPBSE (DPB
	5VK-F137W-11	SCOOP, AIR 1	1	1	1	1	1	UR FOR YB (YB)
12	5VK-28345-00	MOLE 1	1	1	1	1	1	
13	5VK-2414H-00	DAMPER, PLATE 1	1	1	1	1	1	
14	5VK-2414K-00	DAMPER, PLATE 3	1	1	1	1	1	
15	90111-05011	BOLT,HEX. SOCKET BUTTON	2	2	2	2	2	
16	5VK-F137X-01	SCOOP, AIR 2	1	1	1	1	1	UR FOR DPBSE (DPB
	5VK-F137X-11	SCOOP, AIR 2	1	1	1	1	1	UR FOR YB (YB)
17	5VK-28345-00	MOLE 1	1	1	1	1	1	
18	5VK-2414H-00	DAMPER, PLATE 1	1	1	1	1	1	
19	90111-05011	BOLT,HEX. SOCKET BUTTON	2	2	2	2	2	
20	5VK-F137Y-00	GUIDE, AIR	1	1	1	1	1	
21	5VK-28371-00	DAMPER	1	1	1	1	1	
22	90480-01141	GROMMET	2	2	2	2	2	
23	90269-06008	RIVET	4	4	4	4	4	
24	5VK-2416F-00	INSULATOR, FUEL TANK 1	1	1	1	1	1	
25	5VK-F413B-01	EMBLEM	1	1	1	1	1	

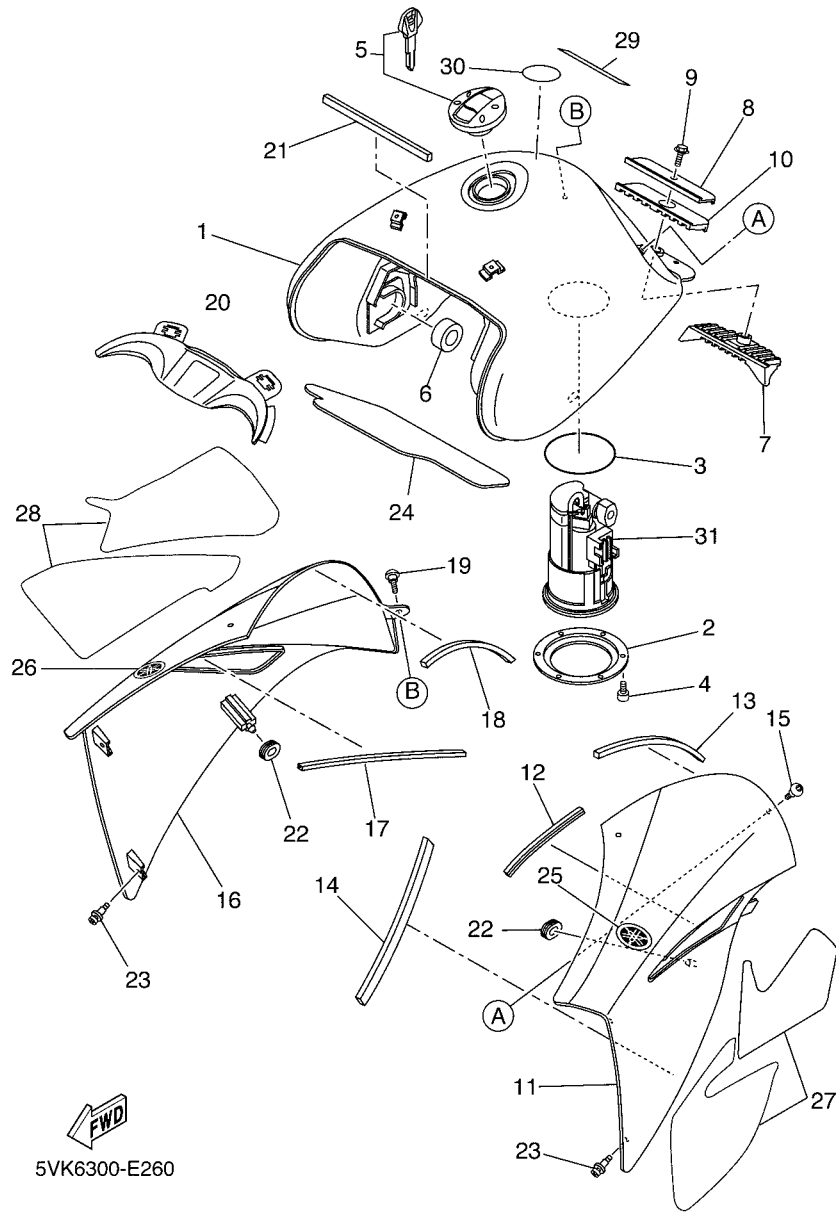


FIG. 26 FUEL TANK

REF. NO.	PART NO.	DESCRIPTION	01	02	03	04	05	REMARKS
26	5VK-F413B-01	EMBLEM	1	1	1	1	1	
27	5VK-2137C-40	GRAPHIC, SCOOP AIR SET 1	1	1	1	1	1	UR FOR DPBSE
	5VK-2137C-50	GRAPHIC, SCOOP AIR SET 1	1	1	1	1	1	UR FOR YB
28	5VK-2137D-40	GRAPHIC, SCOOP AIR SET 2	1	1	1	1	1	UR FOR DPBSE
	5VK-2137D-50	GRAPHIC, SCOOP AIR SET 2	1	1	1	1	1	UR FOR YB
29	5WW-F1568-00	LABEL, WARNING	1	1	1	1	1	
30	5DN-F415A-10	LABEL, CAUTION	1	1	1	1	1	
31	5VK-13907-01	FUEL PUMP COMP.	1	1	1	1	1	UR
	5VK-13907-10	FUEL PUMP COMP.					1	UR

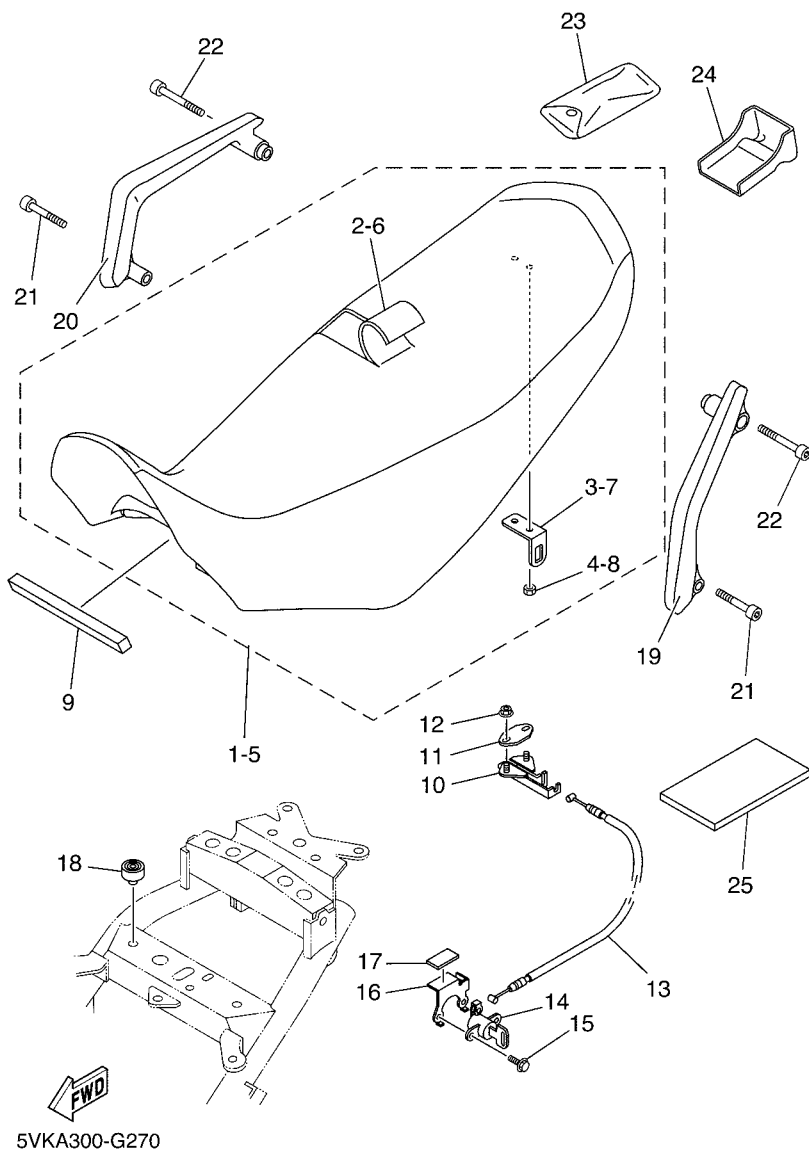
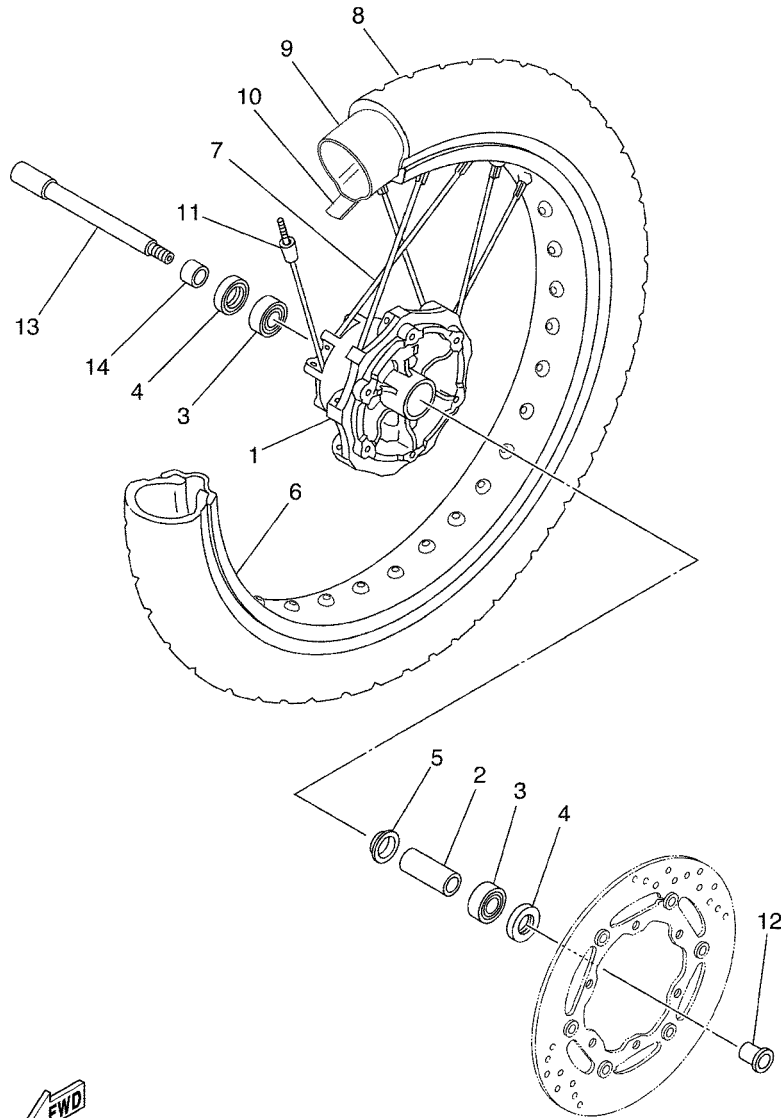


FIG. 27 SEAT

REF. NO.	PART NO.	DESCRIPTION	01	02	03	04	05	REMARKS
1	5VK-F4770-40	SEMI-DOUBLE SEAT ASSY	1	1	1	1	1	UR FOR DPBSE (BLA
2	5VK-24731-40	.COVER, SEAT	1	1	1	1	1	(BLACK/BLUE)
3	4HM-24728-00	.BRACKET, SEAT	1	1	1	1	1	
4	90179-06635	.NUT	1	1	1	1	1	
5	5VK-F4770-30	SEMI-DOUBLE SEAT ASSY	1	1	1	1	1	UR FOR YB (BLACK/
6	5VK-24731-30	.COVER, SEAT	1	1	1	1	1	(BLACK/BLACK)
7	4HM-24728-00	.BRACKET, SEAT	1	1	1	1	1	
8	90179-06635	.NUT	1	1	1	1	1	
9	5VK-24737-00	DAMPER, SEAT	1	1	1	1	1	
10	4BP-24780-00	SEAT LOCK ASSY	1	1	1	1	1	
11	5VK-F4792-00	PLATE	1	1	1	1	1	
12	95707-06500	NUT, FLANGE	2	2	2	2	2	
13	5VK-F478E-00	CABLE, SEAT LOCK	1	1	1	1	1	
14	2TV-W2470-00	ROTOR SET	1	1	1	1	1	
15	95027-06014	BOLT, FLANGE	2	2	2	2	2	
16	5VK-F478X-00	BRACKET, SEAT LOCK	1	1	1	1	1	
17	5VK-24747-00	DAMPER, SEAT	1	1	1	1	1	
18	3VL-F4741-10	PAD, SEAT	2	2	2	2	2	
19	5VK-F474A-10	ASSIST, GRIP	1	1	1	1	1	
20	5VK-F474W-10	ASSIST,GRIP 2	1	1	1	1	1	
21	90110-08X02	BOLT, HEXAGON SOCKET HEAD	2	2	2	2	2	
22	90110-08X06	BOLT, HEXAGON SOCKET HEAD	2	2	2	2	2	
23	5VK-F8100-10	TOOL KIT	1	1	1	1	1	
24	5VK-F8116-00	TOOL, SPECIAL	1	1	1	1	1	
25	5VK-F8199-E1	MANUAL,OWNER'S		1			1	UR ENGLISH
	5VK-F8199-F1	MANUAL,OWNER'S	1	1	1			UR FRENCH
	5VK-F8199-G1	MANUAL,OWNER'S	1	1	1			UR GERMAN



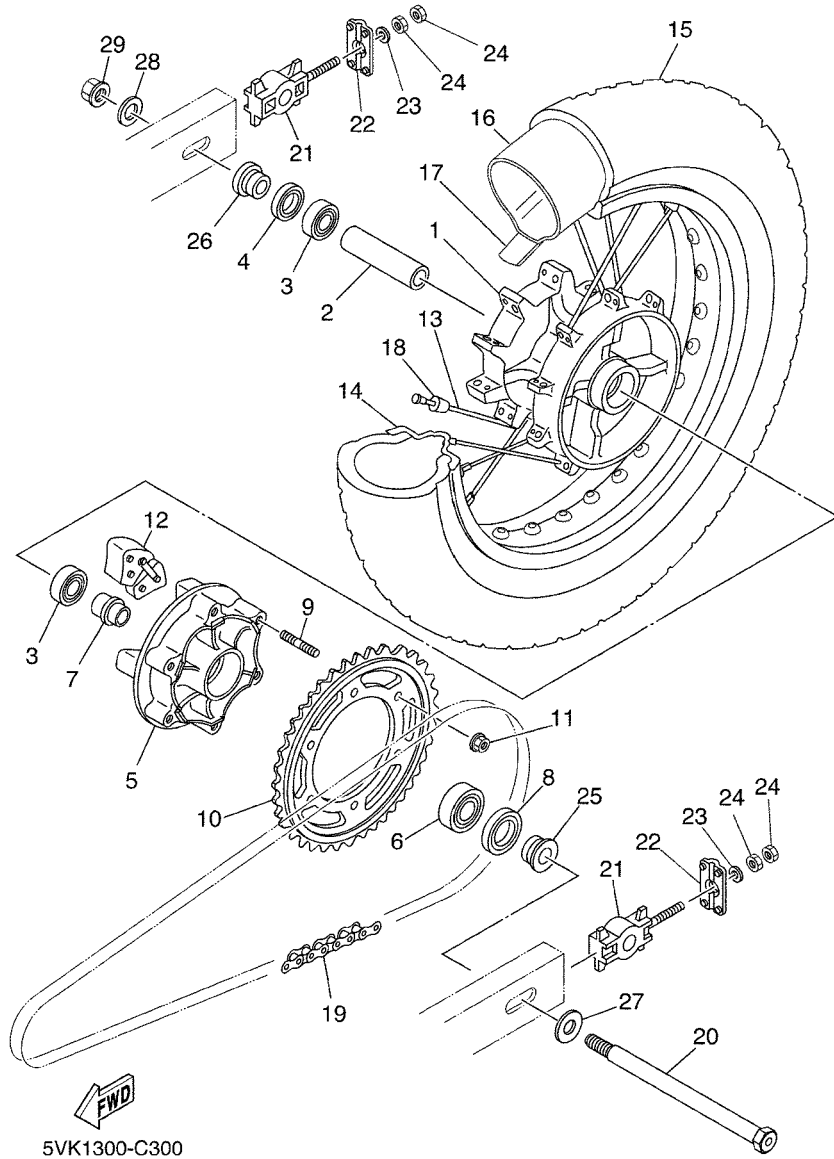
5VK1300-C280

FIG. 28 FRONT WHEEL

REF. NO.	PART NO.	DESCRIPTION	01	02	03	04	05	REMARKS
1	5VK-25111-00	HUB, FRONT	1	1	1	1	1	
2	5VK-25117-00	SPACER, BEARING	1	1	1	1	1	
3	93306-20348	BEARING	2	2	2	2	2	
4	93106-23002	OIL SEAL	2	2	2	2	2	
5	136-25115-00	FLANGE, SPACER 1	1	1	1	1	1	
6	94418-21X01	RIM (1.85-21)	1	1	1	1	1	
7	5VK-F5104-00	SPOKE SET, FRONT	1	1	1	1	1	
8	*	TIRE (90/90-21M/C 54S)	1	1	1	1	1	LM UR METZELER TO
	*	TIRE (90/90-21M/C 54T)	1	1	1	1	1	LM UR MICHELIN SI
9	*	TUBE ( 21 )	1	1	1	1	1	LM UR
	*	TUBE	1	1	1	1	1	LM UR
10	*	BAND, RIM (21)	1	1	1	1	1	LM UR
	*	BAND, RIM	1	1	1	1	1	LM UR
11	3HT-25398-00	BALANCER, WHEEL (15G)	1	1	1	1	1	
12	5VK-F5183-00	COLLAR, WHEEL	1	1	1	1	1	
13	5VK-25181-00	AXLE, WHEEL	1	1	1	1	1	
14	5VK-F5186-00	COLLAR, WHEEL	1	1	1	1	1	



FIG. 30 REAR WHEEL



REF. NO.	PART NO.	DESCRIPTION	01	02	03	04	05	REMARKS
1	5VK-25311-00	HUB, REAR	1	1	1	1	1	
2	90560-17306	SPACER	1	1	1	1	1	
3	93306-20348	BEARING	2	2	2	2	2	
4	93106-23002	OIL SEAL	1	1	1	1	1	
5	5VK-25366-00	CLUTCH, HUB	1	1	1	1	1	
6	93306-30437	BEARING	1	1	1	1	1	
7	1VJ-25377-00	COLLAR, WHEEL	1	1	1	1	1	
8	93106-30029	OIL SEAL	1	1	1	1	1	
9	90116-10485	BOLT, STUD	6	6	6	6	6	
10	5VK-25445-01	SPROCKET, DRIVEN (45T)	1	1	1	1	1	
11	95607-10200	NUT, U FLANGE	6	6	6	6	6	
12	5Y1-25364-00	DAMPER	4	4	4	4	4	
13	5VK-F5304-00	SPOKE SET, REAR	1	1	1	1	1	
14	94427-17X00	RIM	1	1	1	1	1	
15	*	TIRE (130/80-17 M/C 65S)	1	1	1	1	1	LM UR METZELER TO
	*	TIRE (130/80-17 M/C 65T)	1	1	1	1	1	LM UR MICHELIN SI
16	*	TUBE ( 21 )	1	1	1	1	1	LM UR
	*	TUBE	1	1	1	1	1	LM UR
17	*	BAND, RIM (21)	1	1	1	1	1	LM UR
	*	BAND, RIM	1	1	1	1	1	LM UR
18	3HT-25398-00	BALANCER, WHEEL (15G)	1	1	1	1	1	
19	94568-B6110	CHAIN	1	1	1	1	1	
20	3AJ-25381-01	AXLE, WHEEL	1	1	1	1	1	
21	1UF-25388-01	PULLER, CHAIN 1	2	2	2	2	2	
22	5VK-F2174-00	END 1	2	2	2	2	2	
23	92907-08600	WASHER, PLATE	2	2	2	2	2	
24	95307-08600	NUT	4	4	4	4	4	

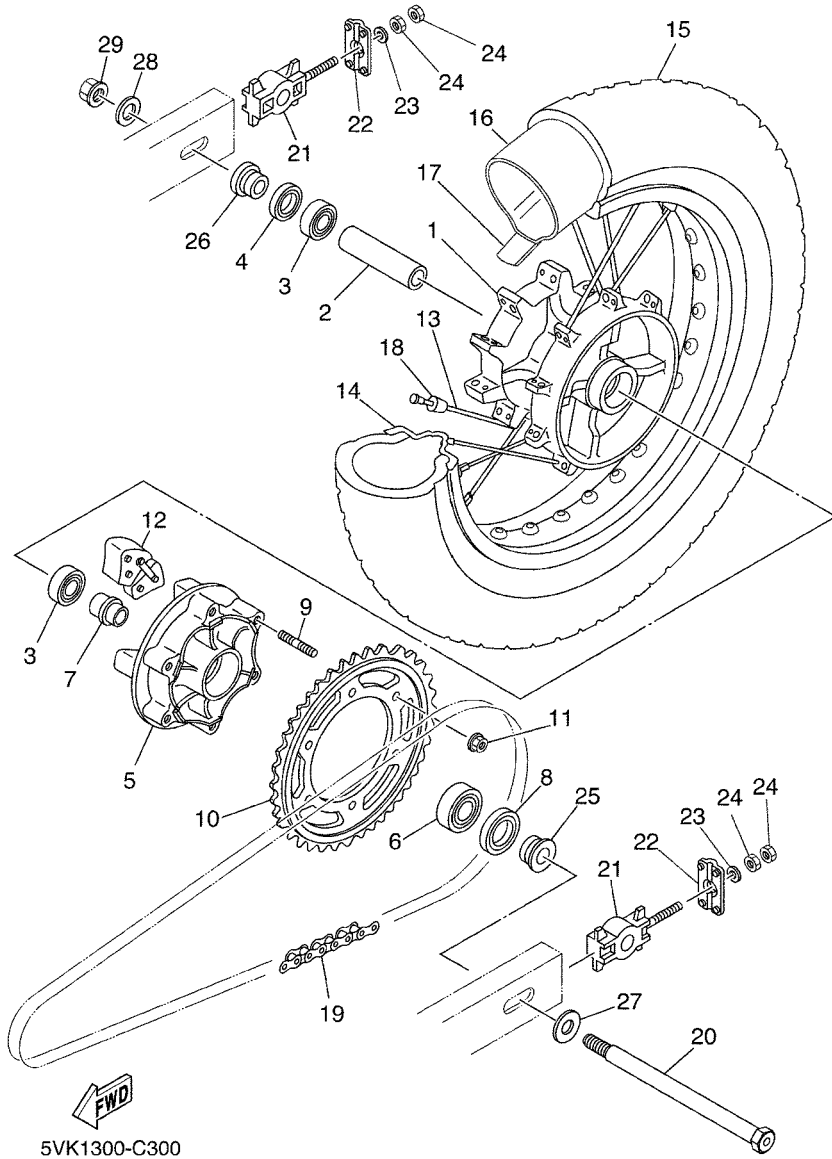
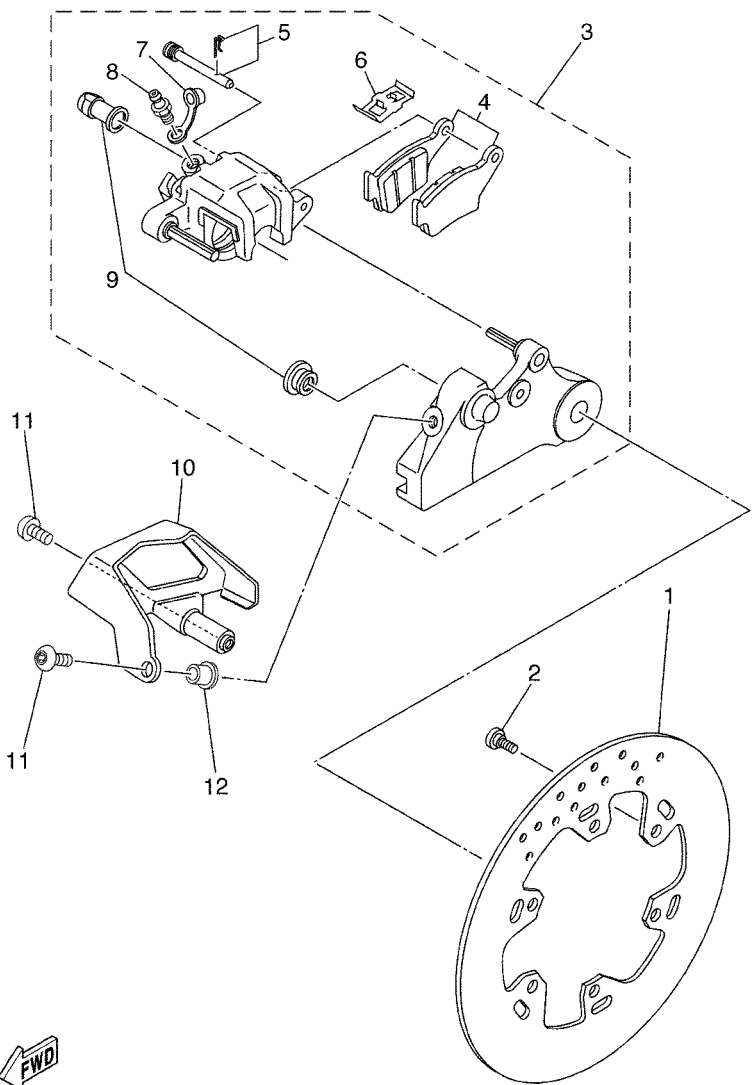


FIG. 30 REAR WHEEL

REF. NO.	PART NO.	DESCRIPTION	01	02	03	04	05	REMARKS
25	90387-17801	COLLAR	1	1	1	1	1	
26	90387-17802	COLLAR	1	1	1	1	1	
27	90201-170T3	WASHER, PLATE	1	1	1	1	1	
28	90201-160T2	WASHER, PLATE	1	1	1	1	1	
29	95604-16200	NUT, U FLANGE	1	1	1	1	1	
-----								
-----								
-----								
-----								
-----								
-----								
-----								
-----								
-----								
-----								

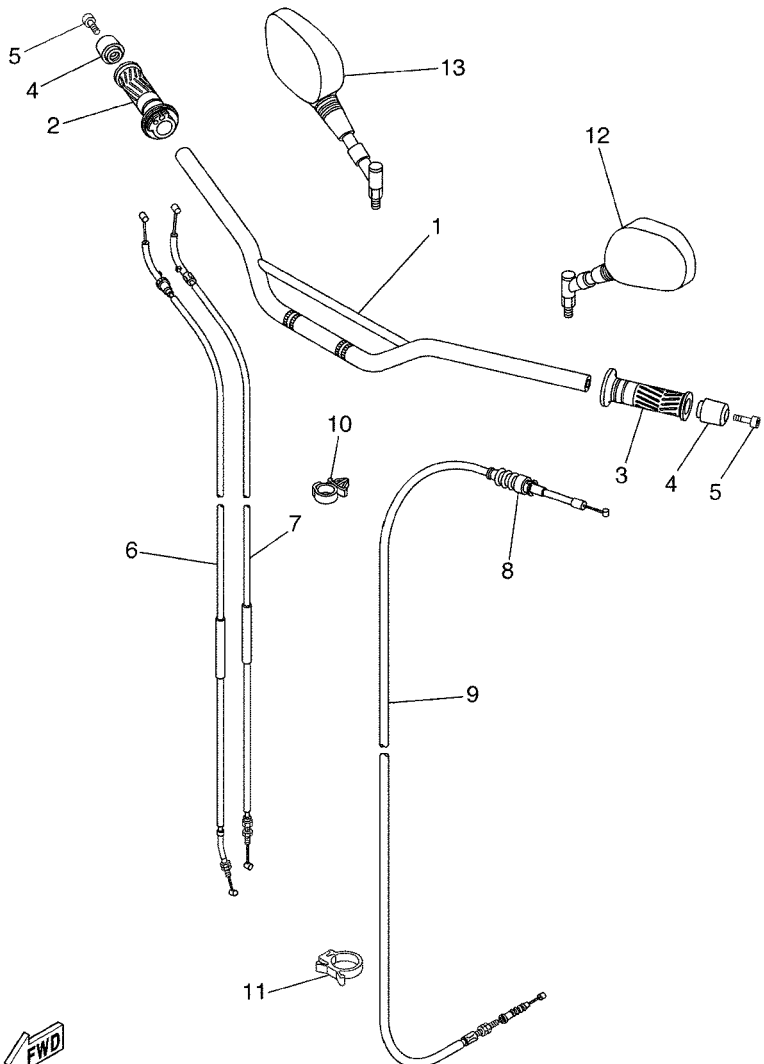
**FIG. 31 REAR BRAKE CALIPER**



  
5VK1300-C310

REF. NO.	PART NO.	DESCRIPTION	01	02	03	04	05	REMARKS
1	5VK-F582W-00	DISK, REAR BRAKE 2	1	1	1	1	1	
2	90109-06816	BOLT	6	6	6	6	6	
3	5VK-F580W-00	CALIPER ASSY, REAR 2	1	1	1	1	1	(BREMBO)
4	5VK-W0046-00	.BRAKE PAD KIT 2	1	1	1	1	1	(BREMBO)
5	5VK-F5924-10	.PIN, PAD	1	1	1	1	1	(BREMBO)
6	5VK-F5919-10	.SUPPORT, PAD	1	1	1	1	1	(BREMBO)
7	5DS-F5825-00	.CAP	1	1	1	1	1	(BREMBO)
8	5SE-F5824-00	.SCREW, BLEED	1	1	1	1	1	(BREMBO)
9	5DS-F5917-00	.BOOT, CALIPER	1	1	1	1	1	(BREMBO)
10	5CH-F7491-00	PROTECTOR	1	1	1	1	1	
11	90111-06029	BOLT,HEX. SOCKET BUTTON	2	2	2	2	2	
12	90387-06852	COLLAR	1	1	1	1	1	

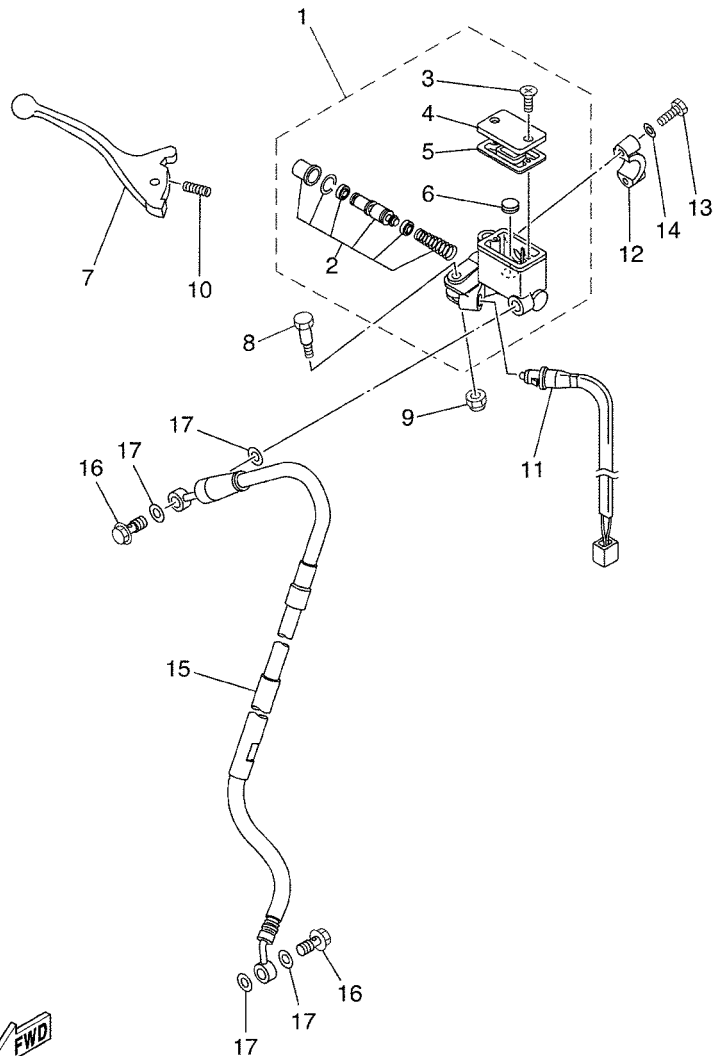
**FIG. 32 STEERING HANDLE & CABLE**



5VK1300-C320

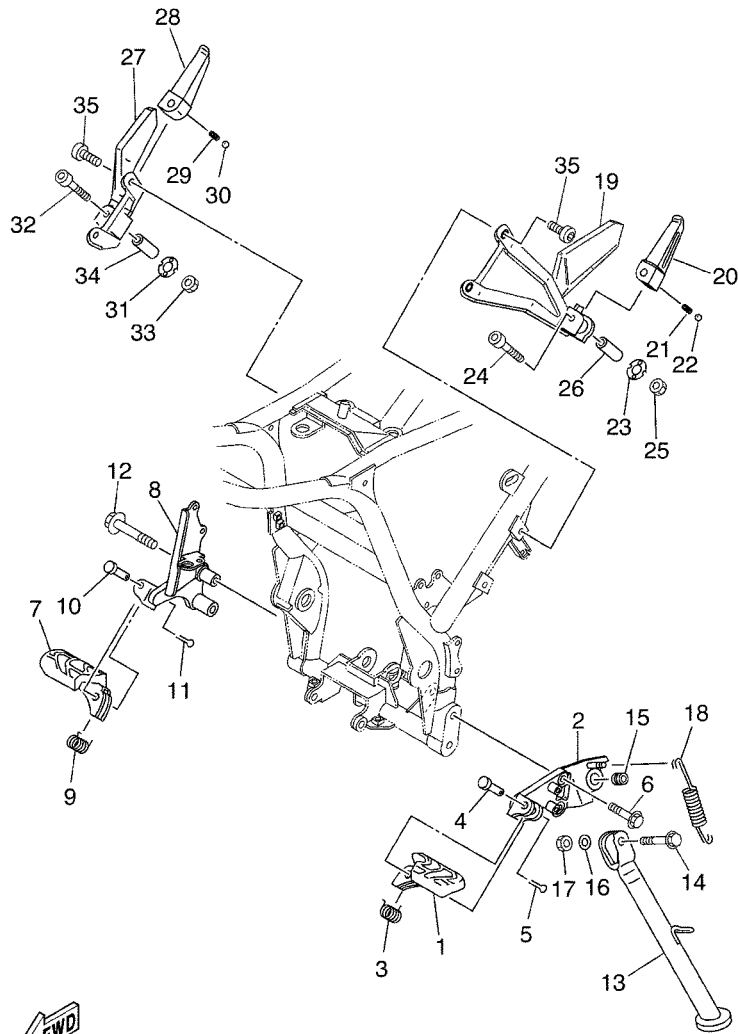
REF. NO.	PART NO.	DESCRIPTION	01	02	03	04	05	REMARKS
1	5VK-26110-00	HANDLE COMP.	1	1	1	1	1	
2	4YR-26240-02	GRIP ASSY	1	1	1	1	1	
3	4YR-26241-02	GRIP (LEFT)	1	1	1	1	1	
4	4JH-26246-00	END, GRIP	2	2	2	2	2	
5	91317-06035	BOLT	2	2	2	2	2	
6	5VK-F6311-00	CABLE, THROTTLE 1	1	1	1	1	1	
7	5VK-F6312-00	CABLE, THROTTLE 2	1	1	1	1	1	
8	1E6-26342-00	BOOT, CABLE	1	1	1	1	1	
9	5VK-F6335-00	CABLE, CLUTCH	1	1	1	1	1	
10	90464-12001	CLAMP	1	1	1	1	1	
11	90464-18004	CLAMP	1	1	1	1	1	
12	5VK-F6280-00	REAR VIEW MIRROR ASSY (LEFT)	1	1	1	1	1	
13	5VK-F6290-00	REAR VIEW MIRROR ASSY (RIGHT)	1	1	1	1	1	

FIG. 33 FRONT MASTER CYLINDER



5VK1300-C330

REF. NO.	PART NO.	DESCRIPTION	01	02	03	04	05	REMARKS
1	5VK-W2587-00	MASTER CYLINDER SUB ASSY	1	1	1	1	1	
2	3XP-W0041-00	.CYLINDER KIT, MASTER	1	1	1	1	1	
3	98706-04012	.SCREW, FLAT HEAD	2	2	2	2	2	
4	3GM-W2585-21	.RESERVOIR CAP SET	1	1	1	1	1	
5	55U-25854-00	.GASKET, DIAPHRAGM	1	1	1	1	1	
6	5CG-25715-00	.SEPARATOR ASSY	1	1	1	1	1	
7	5VK-83922-00	LEVER 2	1	1	1	1	1	
8	90109-06577	BOLT	1	1	1	1	1	
9	95606-06100	NUT, U	1	1	1	1	1	
10	90501-10312	SPRING, COMPRESSION	1	1	1	1	1	
11	5VK-83980-00	FRONT STOP SWITCH ASSY	1	1	1	1	1	
12	56A-25867-00	HOLDER	1	1	1	1	1	
13	97007-06025	BOLT	2	2	2	2	2	
14	92907-06600	WASHER, PLATE	2	2	2	2	2	
15	5VK-F5872-10	HOSE, BRAKE 1	1	1	1	1	1	
16	90401-10X03	BOLT, UNION	2	2	2	2	2	
17	90201-10X03	WASHER, PLATE	4	4	4	4	4	



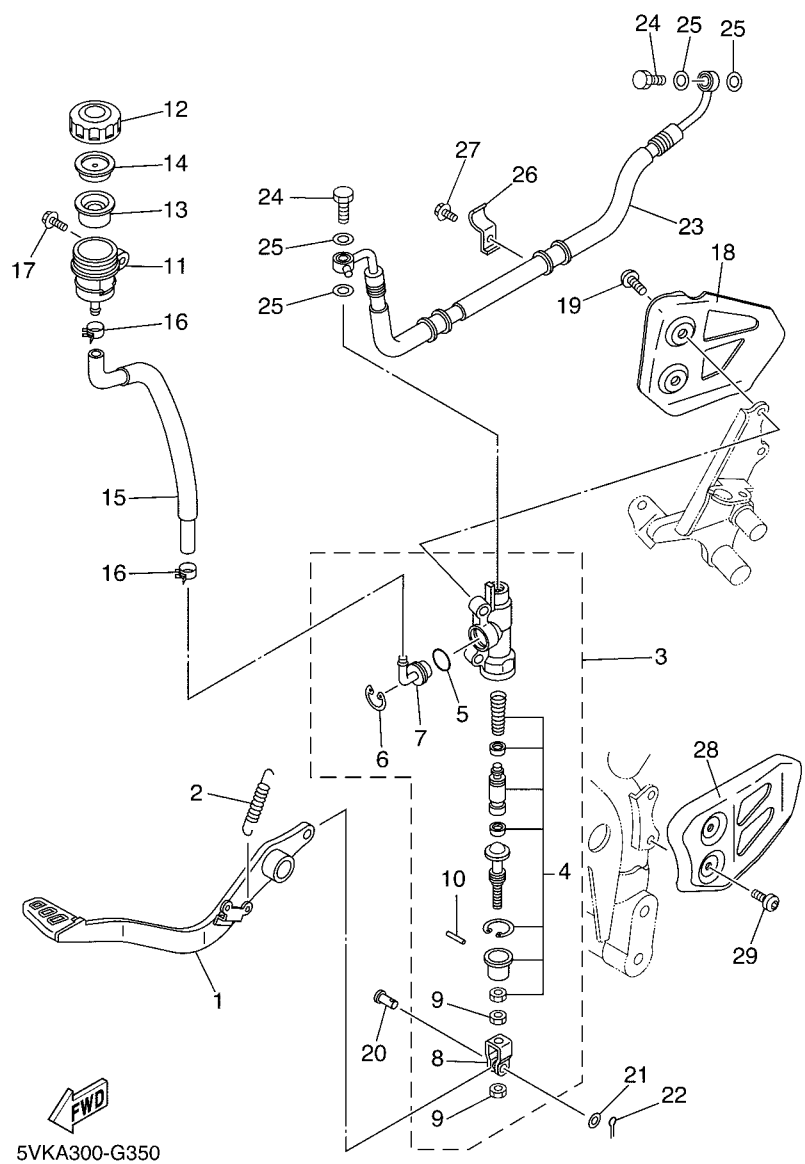
5VK8300-F340

FIG. 34 STAND & FOOTREST

REF. NO.	PART NO.	DESCRIPTION	01	02	03	04	05	REMARKS
1	5VK-F7411-10	FOOTREST 1	1	1	1	1	1	
2	5VK-F7412-10	BRACKET, FOOTREST 1	1	1	1	1	1	
3	90508-20X00	SPRING, TORSION	1	1	1	1	1	
4	90240-10X01	PIN, CLEVIS	1	1	1	1	1	
5	91401-25020	PIN, COTTER	1	1	1	1	1	
6	90105-10813	BOLT, FLANGE	2	2	2	2	2	
7	5VK-F7421-10	FOOTREST 2	1	1	1	1	1	
8	5VK-F7422-10	BRACKET, FOOTREST 2	1	1	1	1	1	
9	90508-20X01	SPRING, TORSION	1	1	1	1	1	
10	90240-10X01	PIN, CLEVIS	1	1	1	1	1	
11	91401-25020	PIN, COTTER	1	1	1	1	1	
12	90105-10811	BOLT, FLANGE	2	2	2	2	2	
13	5VK-F7311-00	STAND, SIDE	1	1	1	1	1	
14	90105-10814	BOLT, FLANGE	1	1	1	1	1	
15	90387-10020	COLLAR	1	1	1	1	1	
16	90201-101J1	WASHER, PLATE	1	1	1	1	1	
17	95617-10100	NUT, U	1	1	1	1	1	
18	90506-20002	SPRING, TENSION	1	1	1	1	1	
19	5VK-F741L-10	BRACKET 4	1	1	1	1	1	
20	5VK-F7431-00	FOOTREST, REAR 1	1	1	1	1	1	
21	90501-12X02	SPRING, COMPRESSION	1	1	1	1	1	
22	93501-04X00	BALL	1	1	1	1	1	
23	5VK-F7437-00	WASHER, SPECIAL	1	1	1	1	1	
24	5VK-F7416-00	BOLT, FOOTREST	1	1	1	1	1	
25	95604-06200	NUT, U FLANGE	1	1	1	1	1	
26	90387-06X37	COLLAR	1	1	1	1	1	
27	5VK-F742L-10	BRACKET 5	1	1	1	1	1	



FIG. 35 REAR MASTER CYLINDER



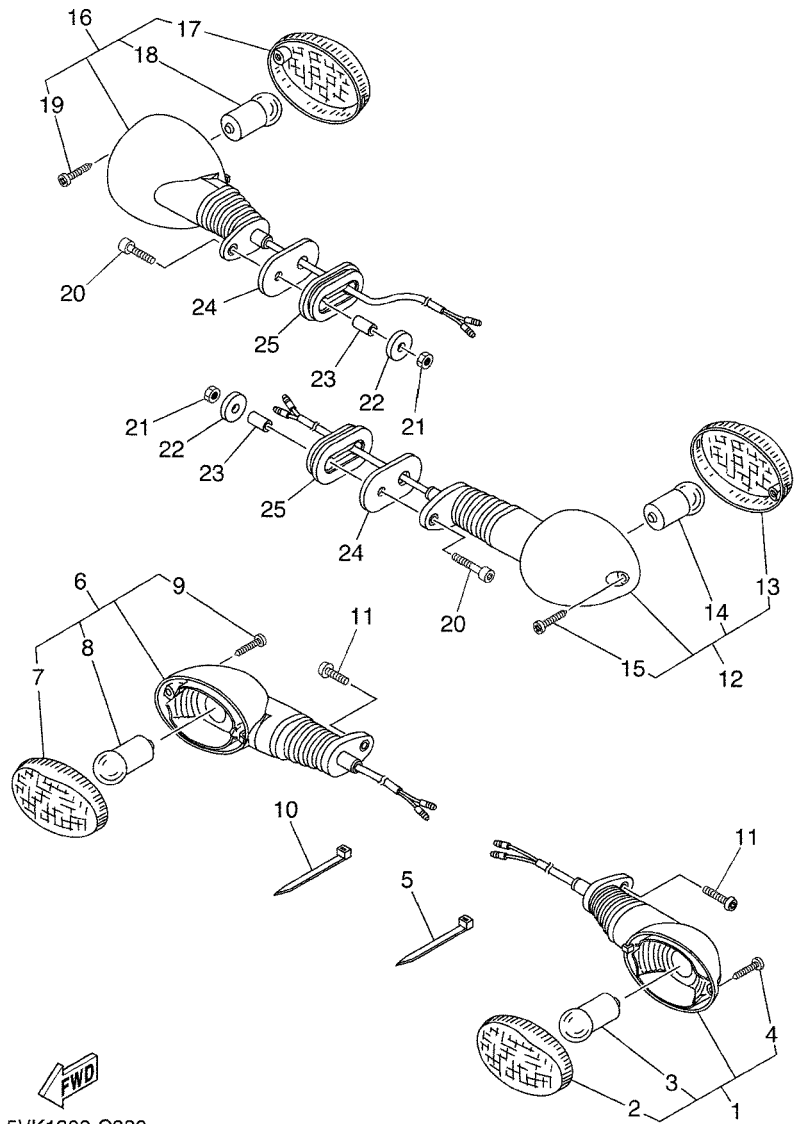
5VKA300-G350

REF. NO.	PART NO.	DESCRIPTION	01	02	03	04	05	REMARKS
1	5VK-F7211-00	PEDAL, BRAKE	1	1	1	1	1	
2	90506-20369	SPRING, TENSION	1	1	1	1	1	
3	5VK-2583V-00	RR. MASTER CYLINDER ASSY.	1	1	1	1	1	
4	3BN-W0042-50	.CYLINDER KIT, MASTER	1	1	1	1	1	
5	93210-15620	.O-RING	1	1	1	1	1	
6	2VN-25866-00	.CIRCLIP	1	1	1	1	1	
7	4ML-2582A-50	.JOINT	1	1	1	1	1	
8	2YK-27222-00	.JOINT	1	1	1	1	1	
9	4SS-27218-00	.NUT	2	2	2	2	2	
10	3KW-27234-00	.PIN, BRAKE ROD	1	1	1	1	1	
11	5JJ-25894-00	TANK, RESERVOIR	1	1	1	1	1	
12	3XP-25852-50	CAP, RESERVOIR	1	1	1	1	1	
13	2VN-25854-00	GASKET, DIAPHRAGM	1	1	1	1	1	
14	2VN-25855-00	BUSH,DIAPHRAGM	1	1	1	1	1	
15	5VK-25895-00	HOSE, RESERVOIR	1	1	1	1	1	
16	90467-12085	CLIP	2	2	2	2	2	
17	90119-06044	BOLT, WITH WASHER	1	1	1	1	1	
18	5VK-F117M-10	COVER 2	1	1	1	1	1	
19	90109-085G6	BOLT	2	2	2	2	2	
20	90240-08124	PIN, CLEVIS	1	1	1	1	1	
21	90201-08083	WASHER, PLATE	1	1	1	1	1	
22	91401-16012	PIN, COTTER	1	1	1	1	1	
23	5VK-F5873-00	HOSE, BRAKE 2	1	1	1	1	1	
24	90401-10X03	BOLT, UNION	2	2	2	2	2	
25	90201-10X03	WASHER, PLATE	4	4	4	4	4	
26	5VK-F5875-00	HOLDER, BRAKE HOSE 1	2	2	2	2	2	
27	95027-06012	BOLT, FLANGE	2	2	2	2	2	







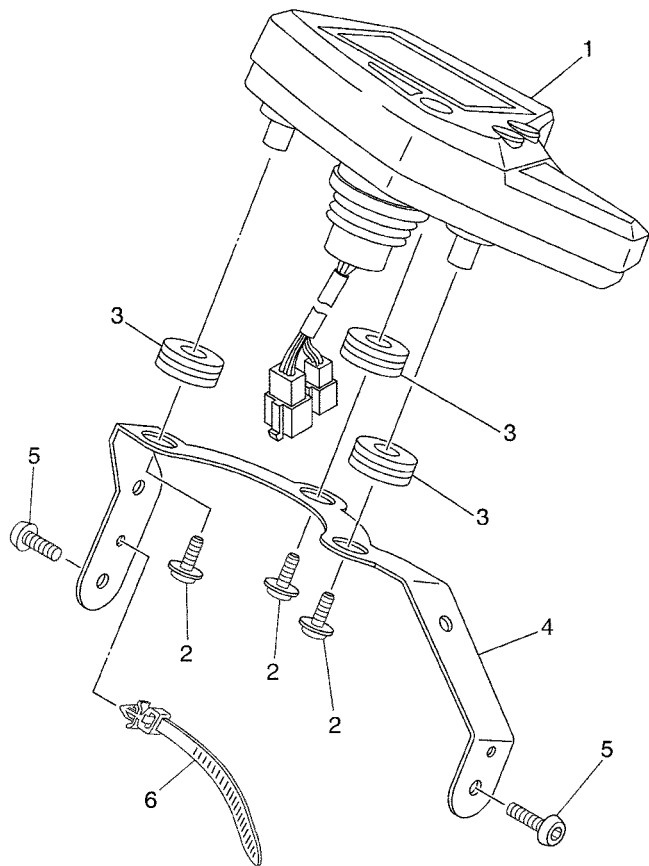


5VK1300-C380

FIG. 38 FLASHER LIGHT

REF. NO.	PART NO.	DESCRIPTION	01	02	03	04	05	REMARKS
1	5VK-H3310-00	FRONT FLASHER LIGHT ASSY 1	1	1	1	1	1	
2	5VK-H333A-00	.LENS COMP	1	1	1	1	1	
3	5VK-H3311-00	.BULB, FLASHER (12V/10W)	1	1	1	1	1	
4	5VK-H3333-00	.SCREW, LENS FITTING	1	1	1	1	1	
5	90464-16061	CLAMP	1	1	1	1	1	
6	5VK-H3320-00	FRONT FLASHER LIGHT ASSY 2	1	1	1	1	1	
7	5VK-H333A-00	.LENS COMP	1	1	1	1	1	
8	5VK-H3311-00	.BULB, FLASHER (12V/10W)	1	1	1	1	1	
9	5VK-H3333-00	.SCREW, LENS FITTING	1	1	1	1	1	
10	90464-16061	CLAMP	1	1	1	1	1	
11	92017-06014	BOLT, BUTTON HEAD	2	2	2	2	2	
12	5VK-H3330-00	REAR FLASHER LIGHT ASSY 1	1	1	1	1	1	
13	5VK-H333A-00	.LENS COMP	1	1	1	1	1	
14	5VK-H3311-00	.BULB, FLASHER (12V/10W)	1	1	1	1	1	
15	5VK-H3333-00	.SCREW, LENS FITTING	1	1	1	1	1	
16	5VK-H3340-00	REAR FLASHER LIGHT ASSY 2	1	1	1	1	1	
17	5VK-H333A-00	.LENS COMP	1	1	1	1	1	
18	5VK-H3311-00	.BULB, FLASHER (12V/10W)	1	1	1	1	1	
19	5VK-H3333-00	.SCREW, LENS FITTING	1	1	1	1	1	
20	91317-06035	BOLT	2	2	2	2	2	
21	95607-06100	NUT, U	2	2	2	2	2	
22	90201-06026	WASHER, PLATE	2	2	2	2	2	
23	90387-06088	COLLAR	2	2	2	2	2	
24	5VK-83359-00	WASHER, SPECIAL	2	2	2	2	2	
25	5VK-83345-00	PLUG, BLIND	2	2	2	2	2	

FIG. 39 METER



5VK1300-C390

REF. NO.	PART NO.	DESCRIPTION	01	02	03	04	05	REMARKS
1	5VK-83500-40	METER ASSY	1	1	1	1	1	UR (KM/H)
2	90164-05014	SCREW, TAPPING	3	3	3	3	3	
3	90480-14555	GROMMET	3	3	3	3	3	
4	5VK-H3519-00	BRACKET, METER	1	1	1	1	1	
5	92017-06014	BOLT, BUTTON HEAD	2	2	2	2	2	
6	90464-12089	CLAMP	1	1	1	1	1	

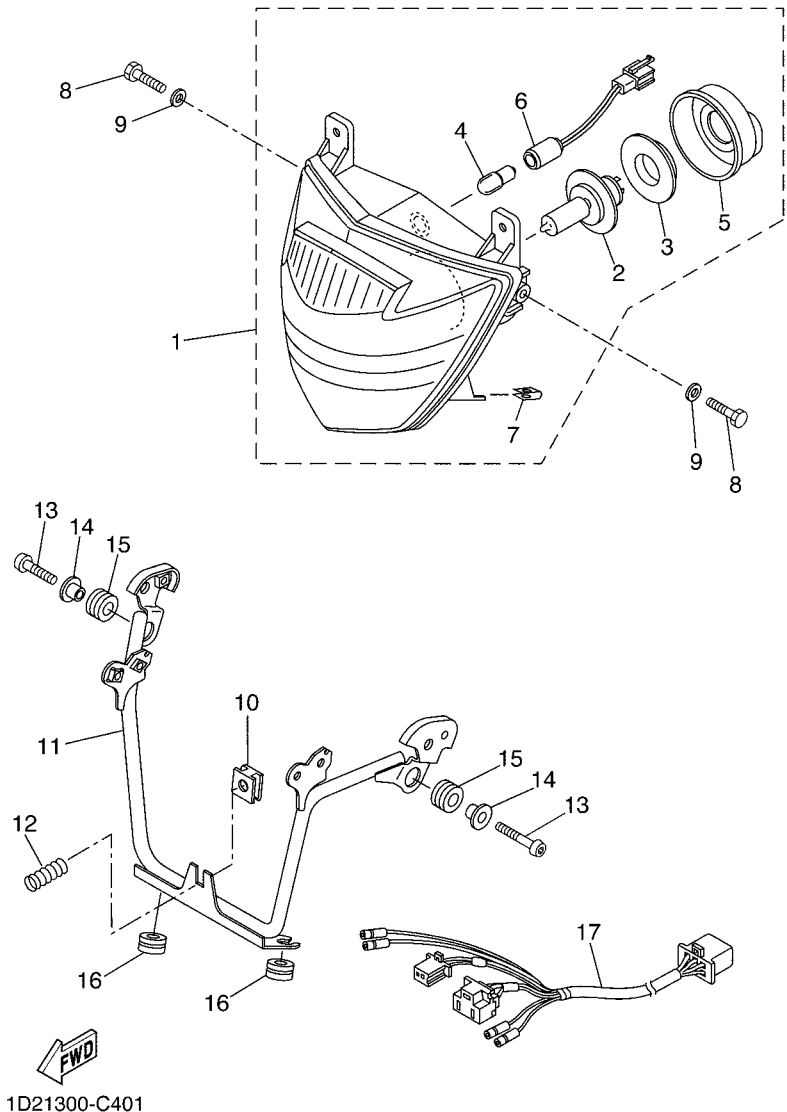
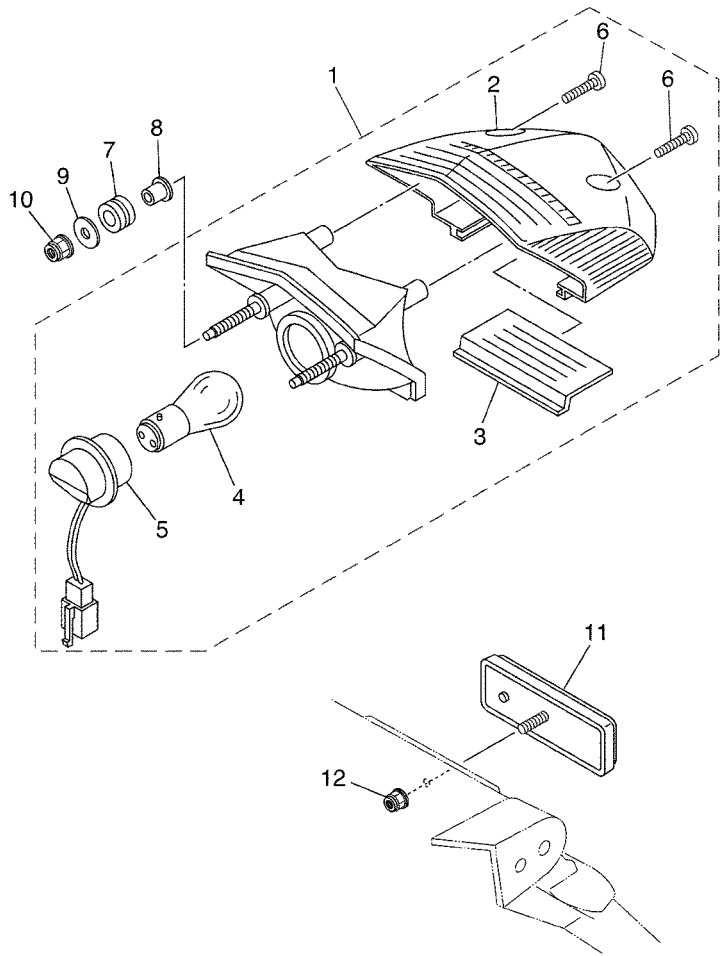


FIG. 40 HEADLIGHT

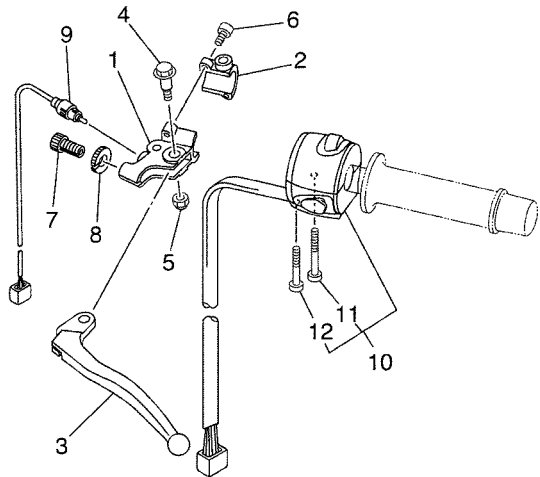
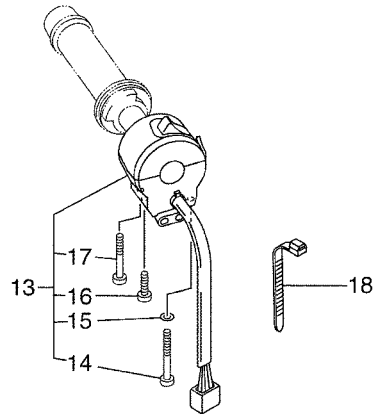
REF. NO.	PART NO.	DESCRIPTION	01	02	03	04	05	REMARKS
1	5VK-H410A-11	HEADLIGHT UNIT COMP.					1	
2	5VK-H4314-00	.BULB, HEADLIGHT	1	1	1	1	1	H4-12V 55/60W
3	5VK-H4393-00	.SPING SUPPORT	1	1	1	1	1	
4	3WW-H4347-00	.BULB (12V-5W)	1	1	1	1	1	
5	5VK-H4397-00	.COVER, SOCKET	1	1	1	1	1	
6	5VK-H4312-00	.CORD ASSY	1	1	1	1	1	
7	90183-05808	.NUT, SPRING	2	2	2	2	2	
8	90101-06815	BOLT	2	2	2	2	2	
9	90201-06839	WASHER, PLATE	2	2	2	2	2	
10	5VK-H4334-00	NUT, ADJUSTING	1	1	1	1	1	
11	5VK-H4118-00	STAY, HEADLIGHT 1	1	1	1	1	1	
12	5VK-H4332-00	SPRING, SCREW	1	1	1	1	1	
13	92017-06020	BOLT, BUTTON HEAD	2	2	2	2	2	
14	90387-065G0	COLLAR	2	2	2	2	2	
15	90480-15058	GROMMET	2	2	2	2	2	
16	90480-15316	GROMMET	2	2	2	2	2	
17	5VK-H4359-10	CORD, HEADLIGHT	1	1	1	1	1	



  
5VK1300-C410

**FIG. 41 TAILLIGHT**

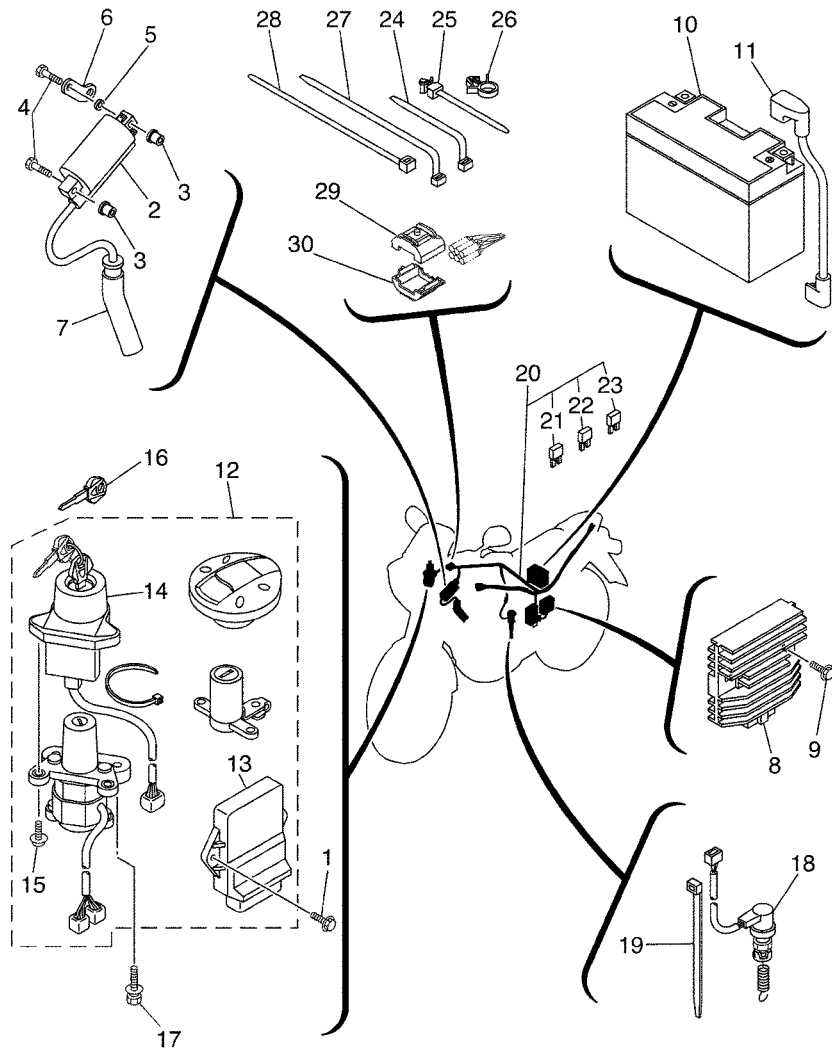
REF. NO.	PART NO.	DESCRIPTION	01	02	03	04	05	REMARKS
1	5VK-H4710-10	TAILLIGHT UNIT ASSY	1	1	1	1	1	
2	5VK-H4721-00	.LENS, TAILLIGHT	1	1	1	1	1	
3	5VK-H4743-00	.LENS, LICENCE LIGHT	1	1	1	1	1	
4	5VK-H4714-00	.BULB (BAY15D 12V-21/5W)	1	1	1	1	1	
5	5VK-H4735-00	.CORD ASSY	1	1	1	1	1	
6	5SE-H4724-00	.SCREW, LENS FITTING	2	2	2	2	2	
7	90480-14329	GROMMET	2	2	2	2	2	
8	90387-065G0	COLLAR	2	2	2	2	2	
9	90201-06057	WASHER, PLATE	2	2	2	2	2	
10	95607-06200	NUT, SELF U-FLANGE	2	2	2	2	2	
11	3NC-H5130-00	REAR REFLECTOR ASSY	1	1	1	1	1	
12	95607-05200	NUT, U FLANGE	1	1	1	1	1	



**FWD**  
5VK1300-C420

**FIG. 42 HANDLE SWITCH & LEVER**

REF. NO.	PART NO.	DESCRIPTION						REMARKS
			01	02	03	04	05	
1	1LN-82911-00	HOLDER, LEVER 1	1	1	1	1	1	
2	33G-82913-01	HOLDER, LEVER LOWER 1	1	1	1	1	1	
3	3FY-83912-01	LEVER 1	1	1	1	1	1	
4	90109-06799	BOLT	1	1	1	1	1	
5	95607-06100	NUT, U	1	1	1	1	1	
6	91317-05020	BOLT	2	2	2	2	2	
7	90123-08046	BOLT	1	1	1	1	1	
8	90179-08148	NUT	1	1	1	1	1	
9	5VK-82917-00	SWITCH	1	1	1	1	1	
10	5VK-83969-00	SWITCH, HANDLE 5	1	1	1	1	1	
11	98507-05030	.SCREW, PAN HEAD	1	1	1	1	1	
12	98507-05045	.SCREW, PAN HEAD	1	1	1	1	1	
13	5VK-83975-00	SWITCH, HANDLE 2	1	1	1	1	1	
14	98507-05055	.SCREW, PAN HEAD	1	1	1	1	1	
15	92907-05600	.WASHER, PLATE	1	1	1	1	1	
16	98507-05045	.SCREW, PAN HEAD	1	1	1	1	1	
17	98507-05020	.SCREW, PAN HEAD	1	1	1	1	1	
18	90464-25004	CLAMP	2	2	2	2	2	



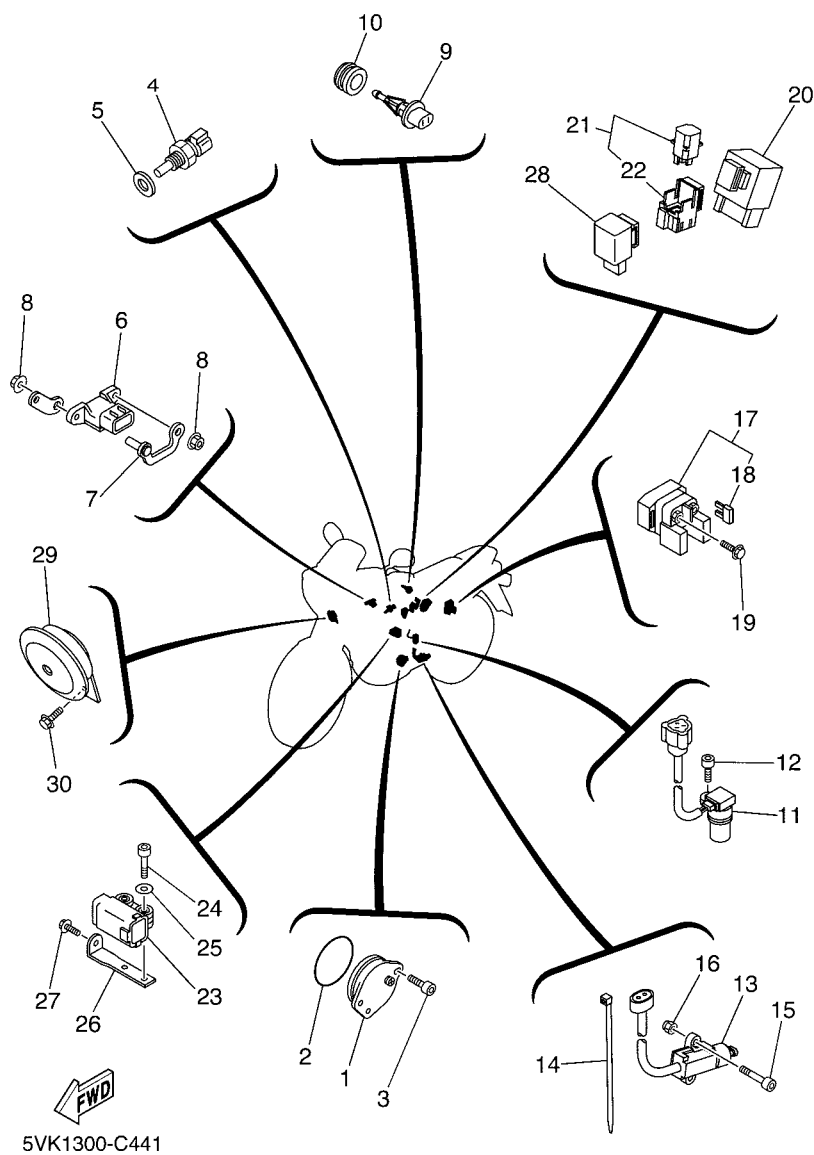
**FWD**  
5VK8300-F430

**FIG. 43 ELECTRICAL 1**

REF. NO.	PART NO.	DESCRIPTION	01	02	03	04	05	REMARKS
1	90119-06192	BOLT, WITH WASHER	2	2	2	2	2	
2	4GV-82310-00	IGNITION COIL ASSY	1	1	1	1	1	
3	90179-05523	NUT	2	2	2	2	2	
4	97007-05025	BOLT	2	2	2	2	2	
5	90201-05556	WASHER, PLATE	1	1	1	1	1	
6	5VK-82312-00	HOLDER, COIL FITTING	1	1	1	1	1	
7	5VK-82370-00	PLUG CAP ASSY	1	1	1	1	1	
8	5SL-81960-00	RECTIFIER & REGULATOR ASSY	1	1	1	1	1	
9	95027-06020	BOLT, FLANGE	2	2	2	2	2	
10	5FL-82100-01	BATTERY ASSY (GT9B-4)	1	1	1	1	1	
11	5VK-H2115-00	WIRE, PLUS LEAD	1	1	1	1	1	
12	5VK-W8250-10	MAIN SW. IMMOBILIZER KIT	1	1	1	1	1	
13	5VK-8591A-10	.ENGINE CONTROL UNIT ASSY	1	1	1	1	1	
14	5VS-8255P-00	.IMMOBILIZER. UNIT COMP.	1	1	1	1	1	
15	5SL-82113-00	.SCREW	2	2	2	2	2	
16	5SL-82511-08	BLANK KEY	1	1	1	1	1	AP
17	90109-080G5	BOLT	2	2	2	2	2	
18	5VK-82530-00	STOP SWITCH ASSY	1	1	1	1	1	
19	90464-16061	CLAMP	2	2	2	2	2	
20	5VK-H2590-20	WIRE HARNESS ASSY	1	1	1	1	1	
21	5JJ-82151-00	.FUSE (7.5A-BL)	2	2	2	2	2	
22	5JJ-82151-30	.FUSE (10A-BL)	6	6	6	6	6	
23	5JJ-82151-20	.FUSE (20A-BL)	2	2	2	2	2	
24	90464-13077	CLAMP	4	4	4	4	4	
25	90464-12089	CLAMP	1	1	1	1	1	
26	90464-15157	CLAMP	1	1	1	1	1	
27	90464-15195	CLAMP	1	1	1	1	1	



FIG. 44 ELECTRICAL 2



5VK1300-C441

REF. NO.	PART NO.	DESCRIPTION	01	02	03	04	05	REMARKS
1	1AE-82540-00	NEUTRAL SWITCH ASSY	1	1	1	1	1	
2	93210-29X00	O-RING	1	1	1	1	1	
3	90110-06122	BOLT, HEXAGON SOCKET HEAD	2	2	2	2	2	
4	5PS-85790-00	THERMOSENSOR ASSY	1	1	1	1	1	
5	90430-12X00	GASKET	1	1	1	1	1	
6	5PS-82380-00	SENSOR, PRESSURE	1	1	1	1	1	
7	5VK-82388-00	PLATE	1	1	1	1	1	
8	95707-06500	NUT, FLANGE	2	2	2	2	2	
9	5VU-85886-00	SENSOR, AIR TEMPRATURE	1	1	1	1	1	
10	5CA-14435-00	GROMMET	1	1	1	1	1	
11	5LP-83755-01	SENSOR, SPEED	1	1	1	1	1	
12	91317-06014	BOLT	1	1	1	1	1	
13	5RT-82566-50	SWITCH, SIDE STAND	1	1	1	1	1	
14	90464-16061	CLAMP	1	1	1	1	1	
15	91317-05035	BOLT	2	2	2	2	2	
16	95607-05100	NUT, U	2	2	2	2	2	
17	4SV-81940-12	STARTER RELAY ASSY	1	1	1	1	1	
18	1AE-82151-00	.FUSE (30A-BL)	2	2	2	2	2	
19	95027-06008	BOLT, FLANGE	2	2	2	2	2	
20	5VK-81950-40	RELAY ASSY	1	1	1	1	1	
21	5JJ-81950-20	RELAY ASSY	2	2	2	2	2	
22	5JJ-81952-00	.HOLDER, RELAY	1	1	1	1	1	
23	5PS-82576-01	LEAN ANGLE SENSOR	1	1	1	1	1	
24	91317-04025	BOLT	2	2	2	2	2	
25	90201-047A2	WASHER, PLATE	2	2	2	2	2	
26	5VK-F1453-00	BRACKET, SWITCH	1	1	1	1	1	
27	95807-06016	BOLT, FLANGE	1	1	1	1	1	



NUMERICAL INDEX

PART NO.	GRID NO.	PART NO.	GRID NO.	PART NO.	GRID NO.	PART NO.	GRID NO.	PART NO.	GRID NO.	PART NO.	GRID NO.
4G0-11133-11	B - 2	5VK-13464-00	B - 10	5VK-2137C-40	D - 11	136-25115-00	D - 14	5VK-81950-40	F - 6	5VK-E1454-00	B - 4
5VK-11166-00	C - 2	5VK-13465-00	B - 10	5VK-2137C-50	D - 11	5VK-25117-00	D - 14	5JJ-81952-00	F - 6	5VK-E1531-00	B - 4
5VK-11181-00	B - 2	5VK-13542-00	B - 12	5VK-2137D-40	D - 11	5VK-25181-00	D - 14	5SL-81960-00	F - 4	5VK-E1536-00	B - 4
214-11198-01	B - 9	5VK-13586-00	B - 11	5VK-2137D-50	D - 11	5VK-25311-00	E - 2	5FL-82100-01	F - 4	5VK-E2151-00	B - 5
5VK-11311-00	B - 3	5VK-13750-11	B - 13	5VK-21445-00	C - 12	5Y1-25364-00	E - 2	5SL-82113-00	F - 4	5VK-E2161-00	B - 5
5VK-11351-00	B - 3	5VK-13761-00	B - 13	1D2-2153A-00	C - 15	5VK-25366-00	E - 2	1AE-82151-00	F - 6	5VK-E2170-10	B - 6
5VK-11400-00	B - 4	5VK-13907-01	D - 11	1D2-2153A-50	C - 15	1VJ-25377-00	E - 2	5JJ-82151-00	F - 4	5VK-E2405-00	B - 8
5VK-11401-09	B - 4	5VK-13907-10	D - 11	5VK-21639-00	C - 14	3AJ-25381-01	E - 2	5JJ-82151-20	F - 4	5VK-E2413-00	B - 8
5VK-11422-00	B - 4	5VK-13971-00	B - 12	5VK-21649-00	C - 15	1UF-25388-01	E - 2	5JJ-82151-30	F - 4	5VK-E2437-00	B - 8
5VK-11603-00	B - 4	558-14147-00	B - 13	5VK-21746-00	C - 13	3HT-25398-00	D - 14	4GV-82310-00	F - 4	5VK-E2437-10	B - 8
5VK-11681-00	B - 4	8CC-14216-10	B - 13	26H-21828-00	D - 2		E - 2	5VK-82312-00	F - 4	5VK-E243A-10	B - 12
5VK-11633-00	B - 4	5CA-14435-00	F - 6	5VK-21875-00	D - 2	5VK-25445-01	E - 2	5VK-82370-00	F - 4	5VK-E2461-00	B - 8
5VK-11651-00	B - 4	5VK-14503-00	B - 13	5VK-22123-00	D - 3	5CG-25715-00	E - 6	5PS-82380-00	F - 6	5VK-E2462-00	B - 8
5VK-11681-00	B - 4	5VK-14531-00	B - 13	5VK-22124-00	D - 3	4ML-2582A-50	E - 9	5VK-82388-00	F - 6	5VK-E2469-00	B - 7
5VK-12111-00	B - 5	3YF-14613-01	B - 15	5VK-22125-00	D - 3	5VK-2583V-00	E - 9	5SL-82511-08	F - 4	5VK-E2498-00	B - 8
5VK-12113-00	B - 5	4EL-14714-00	B - 14	1VJ-22141-00	D - 4	3XP-25852-50	E - 9	5VK-82530-00	F - 4	5VK-E2577-00	B - 7
3YF-12116-00	B - 5	4FU-14714-00	B - 14	10V-22178-00	C - 12	2VN-25854-00	E - 9	1AE-82540-00	F - 6	5VK-E2578-10	B - 8
3YF-12117-01	B - 5	5JX-14725-00	B - 14	30X-22178-00	C - 12	55U-25854-00	E - 6	5VS-8255P-00	F - 4	5VK-E2579-10	B - 8
4G0-12118-00	B - 5	5VK-14803-00	B - 15	10V-22184-00	C - 12	2VN-25855-00	E - 9	5RT-82566-50	F - 6	5VK-E3181-00	B - 9
5H0-12119-00	B - 5	5VK-14815-00	B - 15	30X-2219X-00	D - 3	2VN-25866-00	E - 9	5PS-82576-01	F - 6	5VK-E3327-00	B - 9
5VK-12121-00	B - 5	5VK-14871-02	B - 15	5VK-22210-01	D - 5	56A-25867-00	E - 6	5VS-8258J-00	F - 5	5VK-E3356-00	B - 9
5VK-12146-00	B - 5	5VK-14881-00	B - 15	4AA-22259-40	D - 5	5JJ-25894-00	E - 9	1UA-82591-00	F - 5	5VK-E3415-00	B - 9
5BP-12159-01	B - 5	5VK-15362-00	C - 12	4DA-23145-L0	D - 8	5VK-25895-00	E - 9	5VS-8259J-00	F - 5	5VK-E3545-00	B - 12
3TB-12210-00	B - 6	5VK-15455-00	C - 4	3XJ-23171-L0	D - 8	5VK-26110-00	E - 5	1LN-82911-00	F - 3	5VK-E3591-00	B - 11
4DW-12213-00	B - 6	1VJ-15511-00	C - 5	4V4-23188-L0	D - 8	4YR-26240-02	E - 5	33G-82913-01	F - 3	5VK-E4411-00	B - 11
5VK-12231-00	B - 6	3YF-15515-00	C - 5	5VK-23389-00	D - 6	4YR-26241-02	E - 5	5VK-82917-00	F - 3	5VK-E441A-00	B - 11
5VK-12241-00	B - 6	5VK-15517-00	C - 5	1W1-23416-00	D - 6	4JH-26246-00	E - 5	5VK-83345-00	E - 13	5VK-E441E-00	B - 11
5VK-12280-01	B - 6	5VK-15590-00	C - 5	3YF-23418-00	D - 6	1E6-26342-00	E - 5	4GY-83350-00	F - 7	5VK-E4437-00	B - 11
5VK-12284-00	B - 6	2JN-16154-00	C - 6	5VK-23430-00	D - 6	4SS-27218-00	E - 9	5VK-83359-00	E - 13	5LV-E443E-00	B - 11
5VK-12290-00	B - 6	22U-16321-00	C - 6	4H7-23441-01-P5	D - 6	2YK-27222-00	E - 9	5VK-83500-40	E - 14	5VK-E443E-00	B - 11
5VK-12410-00	B - 8	5TA-16321-00	C - 6	3Y6-23442-00-P1	D - 6	3KW-27234-00	E - 9	5VK-83500-50	E - 14	5VK-E4451-00	B - 11
5VK-12421-00	B - 7	4X7-16325-00	C - 6	5VK-2414H-00	D - 10	5VK-28345-00	D - 10	5LP-83755-01	F - 6	5VK-E4452-00	B - 11
5VK-12422-00	B - 7	5VK-16331-00	C - 6	5VK-2414K-00	D - 10	5DM-28371-00	C - 14	3FY-83912-01	F - 3	5VK-E4453-00	B - 11
5VK-12428-00	B - 7	5VK-16340-00	C - 6	5VK-2416F-00	D - 10	5VK-28371-00	D - 10	5VK-83922-00	E - 6	5VK-E4457-00	B - 11
5VK-12436-00	B - 7	132-16346-00	C - 10	22W-24181-00	B - 14	5VK-2837K-00	E - 11	5VK-83969-00	F - 3	5VK-E4611-10	B - 14
11H-12438-10	B - 7	5VK-16351-00	C - 6	3TB-24181-00	D - 10	5VK-81410-00	E - 12	5VK-83975-00	F - 3	5VK-E4621-00	B - 14
5VK-12450-00	B - 7	4XV-16356-01	C - 6	5VK-24182-00	D - 10	5VK-81450-10	E - 12	5VK-83980-00	E - 6	5VK-E4628-00	B - 14
5VK-12459-00	B - 7	5VK-16371-00	C - 6	5VK-24183-00	D - 10	3AJ-81801-00	C - 5	1FK-84527-00	B - 8	5VK-E4711-10	B - 14
5VK-12481-00	B - 7	5JG-16383-00	C - 6	5JW-24486-00	D - 10	3AJ-81809-00	C - 5	5PS-85790-00	F - 6	5VK-E4721-10	B - 14
583-13113-00	B - 10	5JG-16384-00	C - 6	5VK-24602-00	D - 10	5VK-81815-00	C - 5	3P6-85885-00	B - 13	5VK-E4728-30	B - 14
5VK-13160-00	B - 13	5VK-18101-00	C - 11	4HM-24728-00	D - 12	4XV-8182A-00	C - 5	5VU-85886-00	F - 6	5VK-E4747-00	B - 14
5VK-13161-00	B - 9	5VK-18127-00	C - 10	5VK-24731-30	D - 12	11H-81844-00	C - 5	5VK-8591A-10	F - 4	5VK-E4748-30	B - 14
5VK-13171-00	B - 10	5JW-18140-00	C - 10	5VK-24731-40	D - 12	1FK-81847-00	C - 5	1B9-8592A-00	B - 14	5VK-E4757-00	B - 14
5LP-13300-00	B - 9	5VK-18540-00	C - 10	5VK-24737-00	D - 12	3AJ-81850-00	C - 5	5VK-E1101-00	B - 2	5VK-E4882-00	B - 15
3AJ-13325-00	B - 9	4UN-18542-00	C - 10	1T4-24741-00	C - 14	4G0-81871-00	C - 5	5VK-E111F-00	B - 6	5VK-E5100-00	C - 2
5LP-13329-00	B - 9	4UN-18566-00	C - 10	5VK-24747-00	D - 12	3SX-81890-00	C - 5	5VK-E1167-00	B - 11	5VK-E5118-00	C - 3
4X7-13440-01	B - 9	3YX-21376-00	C - 15	4BP-24780-00	D - 12	4SV-81940-12	F - 6	5VK-E1185-00	B - 2	5VK-E5199-00	C - 5
2WK-13447-00	B - 9	4XV-21376-00	C - 15	5VK-25111-00	D - 14	5JJ-81950-20	F - 6	5VK-E1186-00	B - 2	5VK-E5371-00	B - 11

NUMERICAL INDEX

PART NO.	GRID NO.	PART NO.	GRID NO.	PART NO.	GRID NO.	PART NO.	GRID NO.	PART NO.	GRID NO.	PART NO.	GRID NO.
5VK-E5383-00	C - 2	5VK-F1511-00	C - 14	5VK-F3472-00	D - 6	5VK-F742L-10	E - 7	3BN-W0042-50	E - 9	90119-05193	D - 6
5VK-E5416-00	C - 3	5VK-F1511-10	C - 14	5VK-F4110-10-P0	D - 10	5VK-F7431-00	E - 7	5VK-W0045-00	D - 15	90119-06044	E - 9
5VK-E5421-00	C - 3	5VK-F1556-00	C - 14	5VK-F413B-01	D - 10	5VK-F7437-00	E - 7	5VK-W0046-00	E - 4	90119-06051	C - 14
5VK-E5431-00	C - 3	5WW-F1568-00	D - 11	5DN-F415A-10	D - 11	5VK-F7441-00	E - 8	5VK-W1473-20	B - 14	90119-06096	C - 14
5VK-E5441-01	C - 3	5VK-F1587-00	C - 14	5CH-F4186-00	D - 10	5VK-F7449-00	E - 4	2TV-W2470-00	D - 12	90119-06105	C - 6
5VK-E5451-00	C - 3	5VK-F160E-00	C - 14	5VK-F4491-00	D - 10	5VK-F8100-10	D - 12	3GM-W2585-21	E - 6	90119-06118	C - 14
5VK-E5453-00	C - 4	5VK-F1611-01	C - 14	3VL-F4741-10	D - 12	5VK-F8116-00	D - 12	5VK-W2587-00	E - 6	90119-06192	F - 4
5VK-E5462-00	C - 3	5VK-F1621-00	B - 11	5VK-F474A-10	D - 12	5VK-F8199-E1	D - 12	5VK-W8250-10	F - 4	90119-06861	D - 4
5VK-E5522-00	C - 5	5VK-F1651-00	C - 14	5VK-F474W-10	D - 12	5VK-F8199-F1	D - 12	5VK-WE343-00	B - 9	90119-06X05	B - 6
5VK-E5560-00	C - 5	5VK-F1651-10	C - 14	5VK-F4770-30	D - 12	5VK-F8199-G1	D - 12	5VK-WE541-00	C - 3	90123-08046	F - 3
5VK-E6111-00	C - 6	5VK-F1668-00	D - 4	5VK-F4770-40	D - 12	5VK-F8199-H1	D - 13	5VK-WE544-00	C - 4	90149-05110	B - 9
5VK-E6150-00	C - 6	5VK-F1685-00	C - 14	5VK-F478E-00	D - 12	5VK-F8199-S1	D - 13	90101-06815	E - 15	90149-05321	C - 10
5VK-E6382-00	C - 6	5VK-F1711-00	D - 2	5VK-F478X-00	D - 12	5VK-F8351-10	E - 11	90101-06X26	C - 9	90149-06280	B - 14
5VK-E7121-00	C - 8	5VK-F1721-00	D - 2	5VK-F4792-00	D - 12	5VK-F8381-00	E - 11	90101-08428	C - 12	90149-06298	E - 10
5VK-E7131-00	C - 8	5VK-F1756-00	C - 12	5VK-F5104-00	D - 14	5VK-F8381-20	E - 11	90101-10659	D - 3	90150-05023	E - 11
5VK-E7141-00	C - 8	5VK-F1871-00	D - 2	5VK-F5183-00	D - 14	5VK-H2115-00	F - 4	90101-12742	D - 5	90159-05083	E - 11
5VK-E7141-10	C - 8	5VK-F2110-10	D - 3	5VK-F5186-00	D - 14	5VK-H2116-00	C - 5	90105-05361	D - 6	90159-06078	D - 2
5VK-E7151-00	C - 8	5VK-F2151-00	D - 3	5VK-F5304-00	E - 2	5VK-H2121-00	B - 11	90105-06X06	B - 2	90164-05014	E - 14
5VK-E7151-10	C - 8	5VK-F2174-00	E - 2	5VK-F580T-00	D - 15	5VK-H2122-00	B - 11		B - 8	90169-05801	B - 8
5VK-E7211-00	C - 8	5VK-F217A-00	D - 3	5VK-F580W-00	E - 4	5VK-H2590-20	F - 4	90105-06X20	C - 4	90169-05802	B - 8
5VK-E7221-00	C - 8	5VK-F217F-00	D - 3	5VK-F581T-00	D - 15	5VK-H3310-00	E - 13	90105-07004	B - 6	90170-06128	B - 5
5VK-E7231-00	C - 8	5VK-F2243-00	D - 5	5SE-F5824-00	D - 15	5VK-H3311-00	E - 13	90105-09002	B - 2	90170-18003	B - 4
5VK-E7241-00	C - 8	5VK-F2311-00	D - 4		E - 4	5VK-H3320-00	E - 13	90105-09003	B - 2	90170-20274	C - 6
5VK-E7251-00	C - 8	5VK-F3102-10	D - 8	5DS-F5825-00	D - 15	5VK-H3330-00	E - 13	90105-09004	B - 2	90170-20327	C - 6
5VK-E7401-00	C - 8	5VK-F3103-10	D - 8		E - 4	5VK-H3333-00	E - 13	90105-10040	C - 12	90176-22081	D - 6
5VK-E7402-00	C - 8	5VK-F3110-00	D - 8	5VK-F582W-00	E - 4	5VK-H333A-00	E - 13	90105-10069	D - 15	90179-05523	E - 11
5VK-E7460-10	C - 9	5VK-F3111-00	D - 8	5VK-F5872-10	E - 6	5VK-H3340-00	E - 13	90105-10077	B - 3		F - 4
5VK-E7466-00	C - 3	5VK-F3125-00	D - 8	5VK-F5873-00	E - 9	5VK-H3371-00	F - 7	90105-10078	B - 3	90179-06635	D - 12
5VK-E7471-00	C - 9	5VK-F3126-10	D - 8	5VK-F5875-00	E - 9	5VK-H3519-00	E - 14	90105-10811	E - 7	90179-08148	F - 3
5VK-E8110-01	C - 11	5VK-F3136-10	D - 8	5DS-F5917-00	D - 15	5VK-H410A-01	E - 15	90105-10813	E - 7	90179-08442	B - 15
5VK-E8113-00	C - 11	5VK-F3141-00	D - 8		E - 4	5VK-H410A-11	E - 15	90105-10814	E - 7	90179-10658	C - 12
5VK-E8144-00	C - 10	5VK-F3144-00	D - 8	5VK-F5919-00	D - 15	5VK-H4118-00	E - 15	90109-06419	B - 9	90179-16448	B - 4
5VK-E8501-00	C - 10	5VK-F3146-00	D - 8	5VK-F5919-10	E - 4	5VK-H4312-00	E - 15	90109-06577	E - 6	90179-18003	C - 9
5VK-E8502-00	C - 10	5VK-F3149-00	D - 8	5VK-F5924-00	D - 15	5VK-H4314-00	E - 15	90109-06799	F - 3	90179-25615	D - 6
5VK-E8503-00	C - 10	5VK-F3153-00	D - 8	5VK-F5924-10	E - 4	5VK-H4332-00	E - 15	90109-06816	E - 4	90183-05061	D - 6
5VK-E8699-00	C - 10	5JH-F3158-00	D - 8	5VK-F6280-00	E - 5	5VK-H4334-00	E - 15	90109-080G5	F - 4		E - 11
5VK-F1110-10	C - 12	5VK-F3170-00	D - 8	5VK-F6290-00	E - 5	3WW-H4347-00	E - 15	90109-085E2	B - 15	90183-05808	E - 15
5VK-F117F-10	E - 10	5VK-F3173-00	D - 8	5VK-F6311-00	E - 5	5VK-H4359-10	E - 15	90109-085G6	E - 9	90183-06023	C - 14
5VK-F117M-10	E - 9	5VK-F317E-00	D - 6	5VK-F6312-00	E - 5	5VK-H4393-00	E - 15	90110-06122	F - 6	90185-14002	D - 3
5VK-F1315-00	C - 12	5VK-F317F-00	D - 6	5VK-F6335-00	E - 5	5VK-H4397-00	E - 15	90110-08127	E - 8	90201-047A2	F - 6
5VK-F1316-00	C - 12	5VK-F317M-00	D - 6	5VK-F7211-00	E - 9	5VK-H4710-10	F - 2	90110-08X02	D - 12	90201-05556	F - 4
5VK-F137W-01	D - 10	4CU-F3181-00	D - 9	5VK-F7211-00	E - 7	5VK-H4714-00	F - 2	90110-08X06	D - 12	90201-05X08	E - 12
5VK-F137W-11	D - 10	5VK-F3181-00	D - 8	5VK-F7411-10	E - 7	5VK-H4721-00	F - 2	90111-05011	D - 6	90201-06026	E - 13
5VK-F137X-01	D - 10	5VK-F3340-00	D - 9	5VK-F7412-10	E - 7	5SE-H4724-00	F - 2		D - 10	90201-06057	F - 2
5VK-F137X-11	D - 10	5VK-F334G-00	D - 9	5VK-F7416-00	E - 7	5VK-H4735-00	F - 2	90111-06029	E - 4	90201-064K6	B - 12
5VK-F137Y-00	D - 10	5VK-F334H-00	D - 9	5VK-F741L-10	E - 7	5VK-H4743-00	F - 2	90111-06060	B - 14	90201-06839	E - 15
5VK-F1410-00	C - 12	5SE-F3394-00	D - 9	5VK-F7421-10	E - 7	3NC-H5130-00	F - 2	90111-08823	D - 15	90201-08083	E - 9
5VK-F1453-00	F - 6	5VK-F3466-00	D - 7	5VK-F7422-10	E - 7	3XP-W0041-00	E - 6	90116-10485	E - 2	90201-082H0	C - 12

NUMERICAL INDEX

PART NO.	GRID NO.	PART NO.	GRID NO.	PART NO.	GRID NO.	PART NO.	GRID NO.	PART NO.	GRID NO.	PART NO.	GRID NO.
90201-08X18	C - 5	90340-36X00	C - 3	90462-07X00	C - 2	90480-15058	E - 15	91317-06080	C - 2	93210-35X00	C - 3
90201-08X19	C - 6	90380-22111	D - 3	90462-16X00	C - 3	90480-15316	E - 15	91317-06090	C - 2	93210-41X00	B - 8
90201-096J9	B - 2	90387-05803	C - 14	90464-07259	C - 15	90480-18276	B - 8	91317-06095	B - 9	93210-61750	B - 7
90201-10141	D - 6	90387-06023	B - 14	90464-11008	D - 2		B - 12	91317-08025	C - 5	93210-64X01	B - 9
90201-101A4	B - 3	90387-06042	B - 8	90464-12001	D - 6	90480-20566	B - 11	91317-08030	D - 6	93210-78X00	B - 2
90201-101J1	D - 3	90387-06066	D - 3		E - 5	90501-04X01	B - 10	91380-06016	B - 15	93210-96X00	B - 2
	E - 7	90387-06088	E - 13	90464-12089	E - 14	90501-06022	C - 10	91401-16012	E - 9	93306-00106	B - 7
90201-10X03	E - 6	90387-062M9	D - 2		F - 4	90501-10312	E - 6	91401-25020	E - 7	93306-00304	C - 6
	E - 9	90387-065G0	E - 15	90464-13077	F - 4	90501-12X02	E - 7	91808-16X00	C - 2	93306-004XL	C - 8
90201-10X17	C - 7		F - 2	90464-15157	F - 4	90501-260A1	C - 6		C - 4	93306-004XM	C - 9
90201-10X18	C - 5	90387-065X7	C - 14	90464-15195	F - 4	90506-20002	E - 7	91810-14X00	B - 10	93306-07209	B - 6
90201-12541	B - 7	90387-06648	C - 14	90464-16001	B - 15	90506-20369	E - 9	92017-06014	E - 13	93306-20348	D - 14
90201-12X05	C - 10	90387-06852	E - 4	90464-16006	D - 2	90508-16X00	C - 6		E - 14		E - 2
90201-12X06	C - 10	90387-06X37	E - 7	90464-16061	E - 13	90508-20X00	E - 7	92017-06020	E - 15	93306-205XA	C - 8
90201-13013	D - 4	90387-07037	B - 12		F - 4	90508-20X01	E - 7	92017-06030	E - 12	93306-30437	E - 2
90201-16013	B - 4	90387-075H4	B - 12		F - 6	90560-17306	E - 2	92017-06035	B - 9	93306-305X4	C - 8
90201-160F6	D - 3	90387-07717	D - 2	90464-18004	E - 5	91317-04025	F - 6	92907-05600	F - 3	93306-305YH	B - 4
90201-160T2	E - 3	90387-08024	C - 12	90464-25004	F - 3	91317-05008	B - 9	92907-06600	B - 8	93306-305YJ	B - 4
90201-170T3	E - 3	90387-087L0	C - 14	90464-37257	B - 15	91317-05010	D - 10		E - 6	93306-308Y0	B - 4
90201-17X01	C - 10	90387-10020	E - 7	90465-10044	B - 2	91317-05014	E - 12	92907-08200	C - 12	93310-530C7	C - 5
90201-208G4	C - 8	90387-127W0	D - 3	90465-10045	B - 3	91317-05020	F - 3	92907-08600	E - 2	93310-84010	B - 4
90201-220T0	D - 6	90387-16011	D - 3	90465-12013	C - 2	91317-05035	F - 6	93101-12173	B - 7	93315-11206	C - 10
90201-30X00	B - 4	90387-16012	D - 3	90467-07138	B - 12	91317-06012	B - 7	93101-14164	C - 3	93315-22251	D - 3
90201-30X01	C - 5	90387-167R5	D - 3	90467-08003	D - 2		B - 10	93101-25106	B - 4	93315-31502	C - 7
90202-26142	D - 6	90387-17801	E - 3	90467-10008	B - 10		C - 3	93102-12106	C - 10	93315-31759	D - 3
90209-20012	C - 6	90387-17802	E - 3		C - 13	91317-06014	F - 6	93102-15212	C - 7	93315-32053	D - 3
90209-21351	C - 8	90387-21002	C - 8	90467-11090	B - 12	91317-06016	B - 10	93102-35368	C - 9	93317-11020	C - 6
90209-21X00	C - 8	90387-25802	C - 9	90467-11108	B - 12		C - 2	93106-22019	D - 3	93332-000Y5	D - 6
90209-22X00	C - 8	90401-08133	B - 9	90467-12085	E - 9		D - 7	93106-23002	D - 14	93332-000Y6	D - 6
90209-26348	C - 8	90401-10096	B - 10	90467-12800	B - 11	91317-06018	B - 2		E - 2	93410-11X00	B - 9
90215-18X00	B - 4	90401-10X03	E - 6	90467-13062	B - 11	91317-06020	B - 7	93106-30029	E - 2	93410-17X00	C - 10
90215-20X00	C - 6		E - 9	90467-14015	C - 2		B - 9	93108-35004	D - 3	93410-20825	C - 8
90215-20X01	C - 6	90430-05X00	B - 9	90467-14800	B - 11		C - 11	93109-17071	D - 3	93440-10X00	B - 2
90215-21X00	C - 9	90430-06014	B - 7	90467-17089	B - 15	91317-06025	B - 6	93109-20076	D - 3	93440-11024	C - 5
90240-08124	E - 9	90430-08119	C - 12	90467-170A0	B - 15		B - 10	93210-07X01	B - 9	93440-25084	C - 8
90240-10X01	E - 7	90430-08X01	B - 9	90467-170A2	B - 12		C - 3		C - 2	93440-28062	C - 8
90269-06008	D - 10	90430-09002	B - 13	90467-17128	B - 12	91317-06030	B - 2	93210-10X00	B - 10	93450-24824	B - 4
90269-08066	C - 14	90430-10X00	B - 10	90467-17800	C - 13		C - 2	93210-11X00	B - 9	93501-04X00	E - 7
	D - 4	90430-12X00	F - 6	90467-17801	B - 11		C - 3	93210-13X00	B - 9	93503-08007	B - 10
90280-05001	B - 4	90430-22123	C - 12	90467-19800	C - 13	91317-06035	C - 3		C - 3	93603-16219	B - 7
90282-05058	B - 4	90445-08008	D - 2	90467-23800	B - 11		E - 5	93210-14X00	C - 3	93612-16X00	B - 2
90282-07001	C - 6	90445-08020	D - 2	90480-01141	D - 10		E - 13	93210-15620	E - 9	94418-21X01	D - 14
90338-06004	D - 7	90445-11033	B - 10	90480-01558	D - 2	91317-06040	B - 3	93210-15X00	B - 10	94427-17X00	E - 2
90338-08226	C - 14	90445-12004	B - 12	90480-12581	B - 14	91317-06045	C - 2	93210-19123	C - 12	94568-B6110	E - 2
90338-08801	B - 11	90450-31X00	B - 7	90480-13398	C - 5	91317-06050	B - 7	93210-21X00	B - 7	94591-57126	B - 6
90338-28242	D - 4	90450-32X04	B - 8	90480-14329	F - 2		C - 3	93210-22X00	C - 9	94701-00X09	B - 2
90340-14132	B - 9	90450-59001	B - 11	90480-14555	E - 14	91317-06055	C - 2	93210-29X00	F - 6	95024-08016	C - 12
90340-14X00	C - 3	90450-72001	B - 11	90480-15001	B - 12	91317-06060	C - 2	93210-33X00	B - 7	95024-08040	B - 14

NUMERICAL INDEX

PART NO.	GRID NO.	PART NO.	GRID NO.	PART NO.	GRID NO.	PART NO.	GRID NO.	PART NO.	GRID NO.	PART NO.	GRID NO.
95027-06008	F - 6	97707-60020	C - 14								
95027-06010	F - 7	9770M-50025	B - 11								
95027-06012	B - 6	98507-05020	F - 3								
	E - 9	98507-05030	F - 3								
95027-06014	D - 12	98507-05045	F - 3								
95027-06020	F - 4	98507-05055	F - 3								
95027-06025	B - 7	98507-06012	B - 13								
95027-08040	D - 6	98706-04012	E - 6								
95307-08600	E - 2	99001-07600	C - 6								
95604-06200	E - 7	99001-10600	C - 10								
95604-16200	E - 3	99009-10400	C - 7								
95606-06100	E - 6	99009-12400	B - 7								
95607-05100	F - 6	99530-12016	C - 2								
95607-05200	F - 2		C - 3								
95607-06100	E - 13	99530-14016	C - 2								
	F - 3										
95607-06200	F - 2										
95607-08100	C - 12										
95607-10200	D - 6										
	E - 2										
95607-14200	D - 4										
95614-10100	D - 3										
95617-08618	B - 2										
95617-10100	E - 7										
95617-12100	D - 5										
95704-06500	B - 12										
95707-06500	D - 12										
	F - 6										
95807-06010	B - 8										
95807-06012	C - 14										
	D - 2										
95807-06014	C - 14										
95807-06016	F - 6										
95807-06020	D - 3										
95807-08012	C - 12										
95814-08035	B - 14										
95814-10070	C - 12										
95814-10100	C - 12										
95817-06035	C - 5										
95827-06012	D - 10										
95827-06020	B - 12										
95827-06025	B - 12										
95827-06030	B - 12										
95827-08040	C - 12										
97007-05012	C - 14										
97007-05025	F - 4										
97007-06025	B - 8										
	E - 6										