

PARTS CATALOGUE

XP500'02 (5GJ5) TMAX

YAMAHA
GENUINE
Parts & Accessories

1A5GJ-300E2

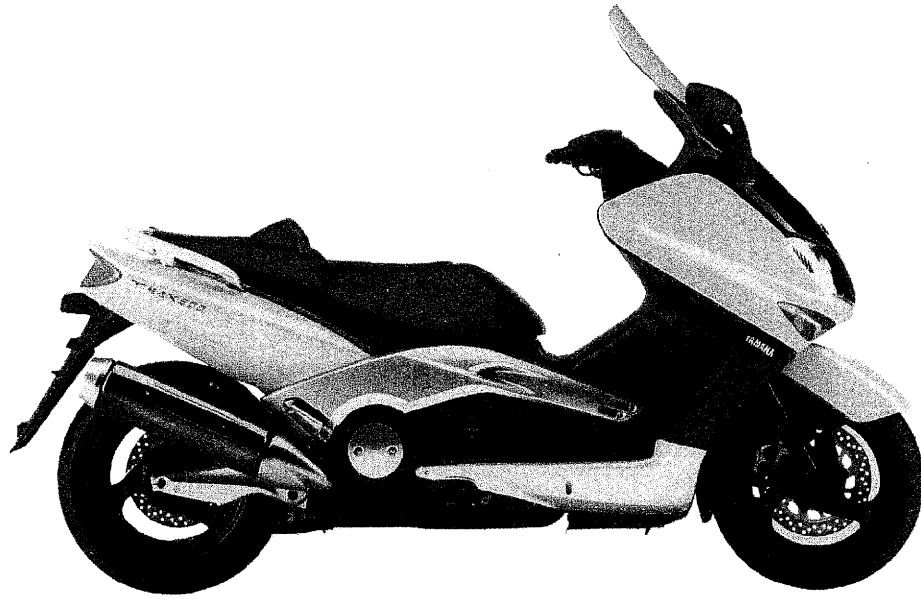

A2

FOREWORD

This Parts Catalogue is related to the parts for the model(s) in the below frame. When you are ordering replacement parts, please refer to this Parts Catalogue and quote both part numbers and part names correctly.

XP500(5GJ5)

1. Modifications or additions which have been made after issue of the Parts Catalogue will be announced in the Yamaha Parts News.
It is advisable that you make necessary corrections to the Parts Catalogue according to the Yamaha Parts News.

2. Abbreviations

The Following abbreviations are used in this Parts Catalogue.

“UR” Use specified parts number.

“UN” Use as many as needed.

“AP” Alternate Parts

“LM” Local Made (Parts need to be ordered locally)

“F#” Frame No. (Applicable machine No.)

3. Parts, which are to be supplied in an assembly, are listed with a dot(.) in front of the part name as shown below.

EXAMPLE

CARBURETOR ASSY

.JET, PILOT

.NOZZLE, MAIN

4. Number of component for assembly

The numeral appearing to the right of each component part indicates the quantity of parts for each assembly unit.

EXAMPLE

PART NO.	DESCRIPTION	Q'TY	REMARKS
2F5-83310-60	FRONT FLASHER LIGHT ASSY	2	
115-83311-60	.BULB (6V-18W)	1	
1M1-83309-60	.REFLECTOR	1	

5. Applicable colors of graphics are represented in the “REMARKS” as shown below.

PART NO.	DESCRIPTION	Q'TY	REMARKS
2N4-24110-00-X5	FUEL TANK COMP.	1	MXR
3J1-24240-10	.GRAPHIC, FUEL TANK	1	FOR MXR

6. Applicable Serial No.

Engine Serial No.

Frame Serial No.

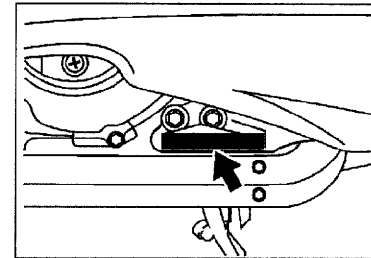
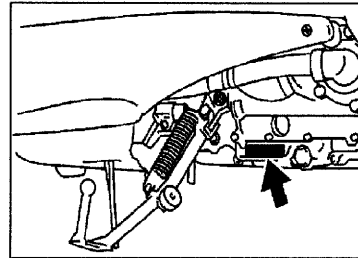

7. Note that the illustrations for reference in finding parts numbers, not to be used for assembling. When assembling, please use the applicable service manual.

8. The asterisk (*) before a reference number indicates modification items after the first edition.

MODEL LABEL

(1) A label called "Model Label" is affixed in the location as indicated in (3) below.
 When using this parts catalogue, please be sure to cross-refer the "model code – production code No." in the catalogue to the "model code – production code No." indicated on the Model Label affixed onto the product concerned.

(2) "Model Label" Indication

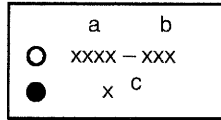

a: Model Type Code
 b: Production Code No.
 c: Colouring Type

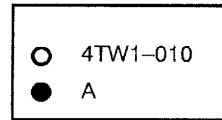

(3) Model Label Affixing Location

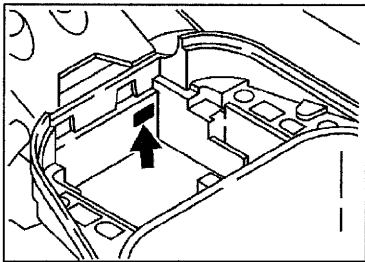

(4) Model Code – Production Code Number of Model Listed in This Parts Catalog

Model Code	Production Code No.	Country (destination)	Model Code	Production Code No.	Country (destination)
5GJ5	010	AUSTRIA			
	030	BELGIUM			
	040	SWITZERLAND			
	080	ENGLAND			
	090	GREECE			
	100	ITALY			
	110	HOLLAND			
	120	PORTUGAL			
	130	SWEDEN			

(5) Colouring Information

Model Code	Colouring type code	Colour code	Colour Name	Abbreviation
5GJ5	A	00AL	CALM YELLOW	CMY

CONTENTS

ENGINE

CYLINDER	B2
CRANKSHAFT, PISTON	B3
VALVE	B5
CAMSHAFT, CHAIN	B7
WATER PUMP	B8
RADIATOR, HOSE	B9
OIL PUMP	B11
INTAKE	B12
CARBURETOR	B14
EXHAUST	C2
CRANKCASE	C4
CRANKCASE COVER 1	C5
CRANKCASE COVER 2	C6
STARTER	C8
CLUTCH	C9
CLUTCH 2	C10
TRANSMISSION	C12
SUB TRANSMISSION	C13

CHASSIS

FRAME	C15
FENDER	D3
SIDE COVER	D4
REAR ARM, SUSPENSION	D7
STEERING	D8
FRONT FORK	D9
FUEL TANK	D11
SEAT	D12
SEAT 2	D14

FRONT WHEEL	E2
FRONT BRAKE CALIPER	E3
REAR WHEEL	E4
REAR BRAKE CALIPER	E5
STEERING HANDLE, CABLE	E6
FRONT MASTER CYLINDER	E7
STAND, FOOTREST	E9
STAND, FOOTREST 2	E11
LEG SHIELD	E13
WINDSHIELD	E15
GENERATOR	F3
FLASHER LIGHT	F4
METER	F5
HEADLIGHT	F6
TAILLIGHT	F7
HANDLE SWITCH, LEVER	F8
ELECTRICAL 1	F9
ELECTRICAL 2	F11

FIG. 1 CYLINDER

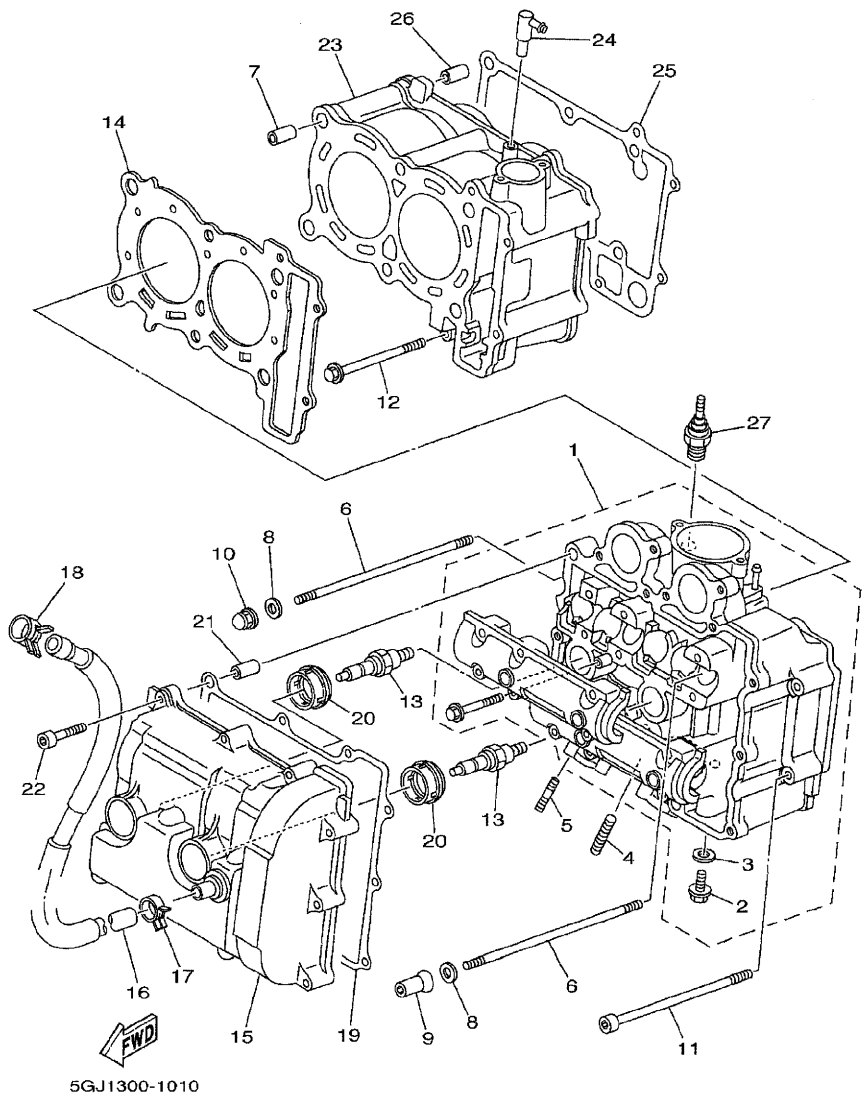

REF. NO.	PART NO.	DESCRIPTION	5GJ5				REMARKS
1	5GJ-11101-00	CYLINDER HEAD ASSY	1				
2	95027-08012	.BOLT, FLANGE	1				
3	90430-08119	.GASKET	1				
4	95617-08620	BOLT, STUD	4				
5	90116-06475	BOLT, STUD	4				
6	90116-09584	BOLT, STUD	6				
7	93612-16254	PIN, DOWEL	2				
8	90201-090P4	WASHER, PLATE	6				
9	90179-09612	NUT	4				
10	90179-09489	NUT	2				
11	90110-06021	BOLT, HEXAGON SOCKET HEAD	2				
12	95027-06085	BOLT, FLANGE	1				
13	NGK-C7E-PK10	PLUG, SPARK (NGKCR7E)	2				
14	5GJ-11181-00	GASKET, CYLINDER HEAD 1	1				
15	5GJ-11190-00	COVER, CYLINDER HEAD 1	1				
16	5GJ-11166-00	PIPE, BREATHER 1	1				
17	90467-13071	CLIP	1				
18	90467-16181	CLIP	1				
19	5GJ-11193-00	GASKET, HEAD COVER 1	1				
20	5GJ-11195-00	GASKET	2				
21	99530-10116	PIN, DOWEL	2				
22	91317-06035	BOLT	10				
23	5GJ-11311-00	CYLINDER 1	1				
24	4BR-14251-00	NIPPLE	1				
25	5GJ-11351-00	GASKET, CYLINDER	1				
26	93612-16254	PIN, DOWEL	2				
27	46X-83591-00	THERMO UNIT	1				

FIG. 2 CRANKSHAFT. PISTON

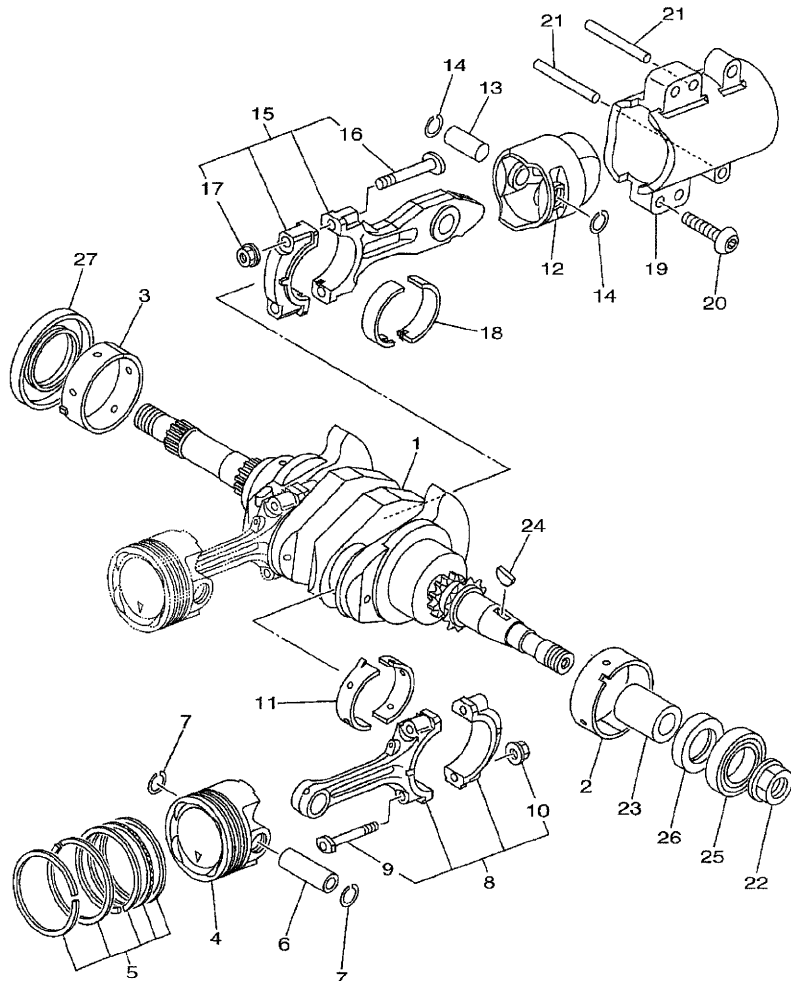

5GJ1300-1020

REF. NO.	PART NO.	DESCRIPTION	5GJ5			REMARKS
1	5GJ-W1141-00	CRANK 1	1			
2	5GJ-11416-00	PLANE BEARING, CRANKSHAFT 1	1			UR
	5GJ-11416-10	PLANE BEARING, CRANKSHAFT 1	1			UR
	5GJ-11416-20	PLANE BEARING, CRANKSHAFT 1	1			UR
	5GJ-11416-30	PLANE BEARING, CRANKSHAFT 1	1			UR
	5GJ-11416-40	PLANE BEARING, CRANKSHAFT 1	1			UR
	5GJ-11416-A0	PLANE BEARING, CRANKSHAFT 1	1			UR
3	5GJ-11417-00	PLANE BEARING, CRANKSHAFT 2	1			UR
	5GJ-11417-10	PLANE BEARING, CRANKSHAFT 2	1			UR
	5GJ-11417-20	PLANE BEARING, CRANKSHAFT 2	1			UR
	5GJ-11417-30	PLANE BEARING, CRANKSHAFT 2	1			UR
	5GJ-11417-40	PLANE BEARING, CRANKSHAFT 2	1			UR
	5GJ-11417-A0	PLANE BEARING, CRANKSHAFT 2	1			UR
4	5GJ-11631-00	PISTON (STD)	2			
5	5GJ-11603-00	PISTON RING SET (STD)	2			
6	5EB-11633-00	PIN, PISTON	2			
7	93450-17129	CIRCLIP	4			
8	5GJ-11650-00	CONNECTING ROD ASSY	2			
9	5GJ-11654-00	.BOLT, CONNECTING ROD	2			UR
	5GJ-11654-10	.BOLT, CONNECTING ROD	2			UR
10	90179-07652	.NUT	2			
11	5GJ-11656-00	PLANE BEARING, CONNECTING ROD	4			UR
	5GJ-11656-10	PLANE BEARING, CONNECTING ROD	4			UR
	5GJ-11656-20	PLANE BEARING, CONNECTING ROD	4			UR
	5GJ-11656-30	PLANE BEARING, CONNECTING ROD	4			UR
12	5GJ-11642-10-A0	PISTON 2 (STD)	1			
13	5GJ-11455-10	SHAFT 1	1			

FIG. 2 CRANKSHAFT. PISTON

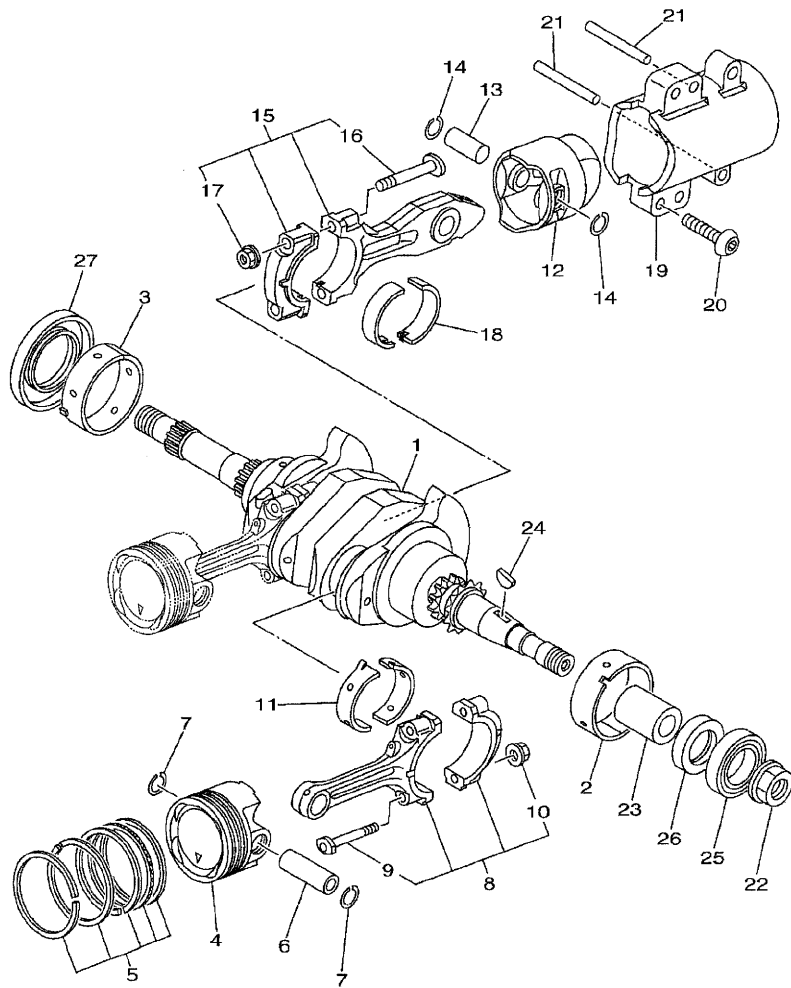

5GJ1300-1020

REF. NO.	PART NO.	DESCRIPTION	5GJ15				REMARKS
14	93450-16068	CIRCLIP	2				
15	5GJ-11660-10	CONNECTING ROD ASSY	1				
16	4X7-11654-01	.BOLT, CONNECTING ROD	2				
17	90179-09379	.NUT	2				
18	5GJ-11656-00	PLANE BEARING, CONNECTING ROD	2				UR
	5GJ-11656-10	PLANE BEARING, CONNECTING ROD	2				UR
	5GJ-11656-20	PLANE BEARING, CONNECTING ROD	2				UR
	5GJ-11656-30	PLANE BEARING, CONNECTING ROD	2				UR
19	5GJ-11312-00	SLEEVE, CYLINDER	1				
20	90111-10002	BOLT	4				
21	93608-60001	PIN, DOWEL	2				
22	90179-18002	NUT	1				
23	90387-18001	COLLAR	1				
24	90280-05013	KEY, WOODRUFF	1				
25	93306-90602	BEARING	1				
26	93101-30001	OIL SEAL	1				
27	93102-44008	OIL SEAL	1				

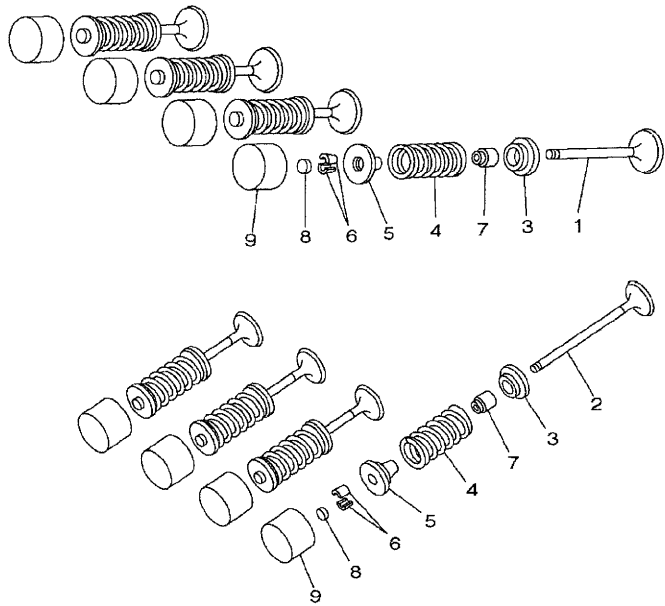

FIG. 3 VALVE

REF. NO.	PART NO.	DESCRIPTION	5GJ15				REMARKS
1	5GJ-12111-00	VALVE, INTAKE	4				
2	5GJ-12121-00	VALVE, EXHAUST	4				
3	5EB-12126-00	SEAT, VALVE SPRING 2	8				
4	4GY-12113-00	SPRING, VALVE INNER	8				
5	5EB-12127-00	RETAINER, VALVE SPRING	8				
6	1HX-12118-00	COTTER, VALVE	16				
7	4TV-12119-00	SEAL, VALVE STEM	8				
8	1HX-12168-00	PAD, ADJUSTING 2 (1.20)	8				UR
	1HX-12168-20	PAD, ADJUSTING 2 (1.25)	8				UR
	1HX-12168-40	PAD, ADJUSTING 2 (1.30)	8				UR
	1HX-12168-60	PAD, ADJUSTING 2 (1.35)	8				UR
	1HX-12168-80	PAD, ADJUSTING 2 (1.40)	8				UR
	1HX-12168-A0	PAD, ADJUSTING 2 (1.45)	8				UR
	1HX-12168-F0	PAD, ADJUSTING 2 (1.50)	8				UR
	1HX-12168-H1	PAD, ADJUSTING 2 (1.55)	8				UR
	1HX-12168-K1	PAD, ADJUSTING 2 (1.60)	8				UR
	1HX-12168-M1	PAD, ADJUSTING 2 (1.65)	8				UR
	1HX-12168-R1	PAD, ADJUSTING 2 (1.70)	8				UR
	1HX-12168-U1	PAD, ADJUSTING 2 (1.75)	8				UR
	1HX-12168-W1	PAD, ADJUSTING 2 (1.80)	8				UR
	1HX-12168-Y1	PAD, ADJUSTING 2 (1.85)	8				UR
	1HX-12169-11	PAD, ADJUSTING 2 (1.90)	8				UR
	1HX-12169-31	PAD, ADJUSTING 2 (1.95)	8				UR
	1HX-12169-50	PAD, ADJUSTING 2 (2.00)	8				UR
	1HX-12169-70	PAD, ADJUSTING 2 (2.05)	8				UR
	1HX-12169-90	PAD, ADJUSTING 2 (2.10)	8				UR
	1HX-12169-E0	PAD, ADJUSTING 2 (2.15)	8				UR

5GJ1300-1030

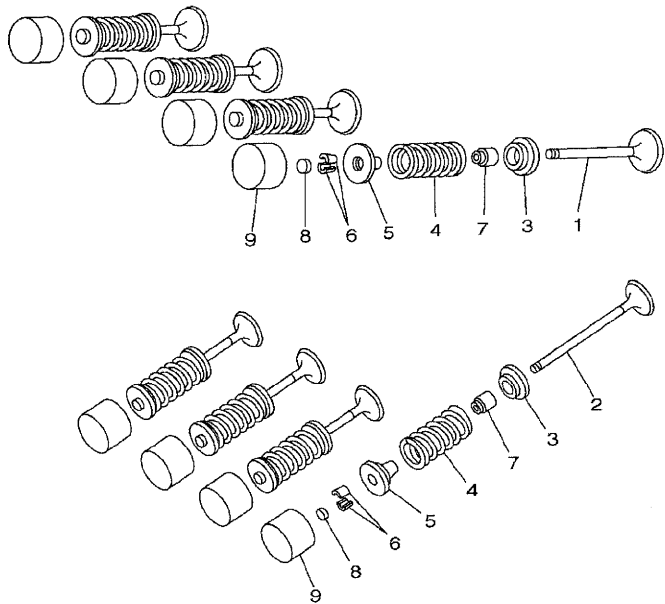

FIG. 3 VALVE

REF. NO.	PART NO.	DESCRIPTION	5GJ5			REMARKS
8	1HX-12169-G0	PAD, ADJUSTING 2 (2.20)	8			UR
	1HX-12169-J0	PAD, ADJUSTING 2 (2.25)	8			UR
	1HX-12169-L0	PAD, ADJUSTING 2 (2.30)	8			UR
	1HX-12169-N0	PAD, ADJUSTING 2 (2.35)	8			UR
	1HX-12169-T0	PAD, ADJUSTING 2 (2.40)	8			UR
9	5EB-12153-20	LIFTER, VALVE	8			UR BLUE
	5EB-12153-09	LIFTER, VALVE	8			UR GREEN



5GJ1300-1030

FIG. 4 CAMSHAFT. CHAIN

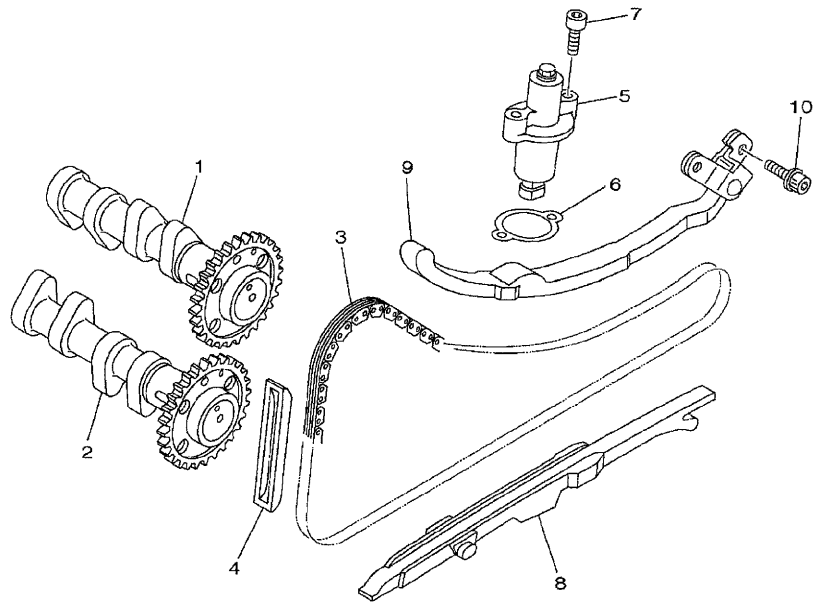

REF. NO.	PART NO.	DESCRIPTION	5GJ15	REMARKS
1	5GJ-12170-00	CAMSHAFT ASSY 1	1	
2	5GJ-12180-00	CAMSHAFT ASSY 2	1	
3	94581-89132	CHAIN	1	
4	5BE-12241-00	GUIDE, STOPPER 2	1	
5	5GJ-12210-00	TENSIONER ASSY, CAM CHAIN	1	
6	4FM-12213-00	GASKET, TENSIONER CASE	1	
7	91317-06025	BOLT	2	
8	5GJ-12251-00	DAMPER, CHAIN 1	1	
9	5GJ-12252-00	DAMPER, CHAIN 2	1	
10	90119-06020	BOLT, WITH WASHER	2	

 5GJ1300-1040

FIG. 5 WATER PUMP

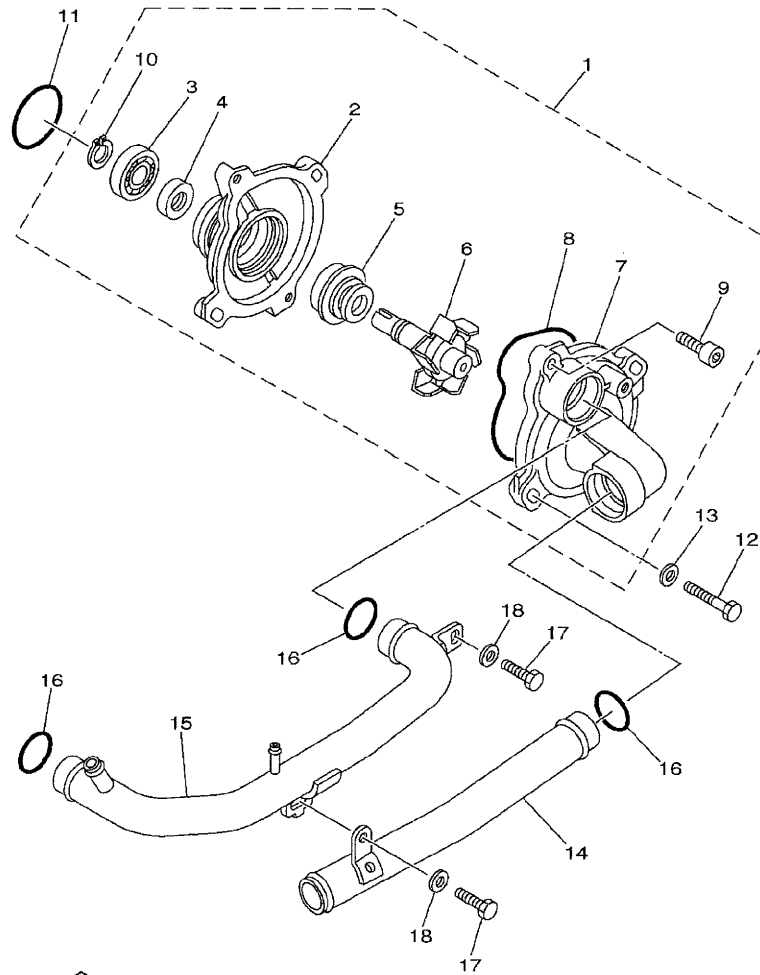

REF. NO.	PART NO.	DESCRIPTION	5GJ15				REMARKS
1	5GJ-12420-00	WATER PUMP ASSY	1				
2	5GJ-12421-00	.HOUSING, WATER PUMP	1				
3	93306-00106	.BEARING	1				
4	93102-12442	.OIL SEAL	1				
5	11H-12438-10	.SEAL, MECHANICAL	1				
6	5GJ-12450-00	.IMPELLER SHAFT ASSY	1				
7	5GJ-12422-00	.COVER, HOUSING	1				
8	1WG-12439-00	.O-RING	1				
9	91317-06020	.BOLT	2				
10	99009-12400	.CIRCLIP	1				
11	93210-33133	O-RING	1				
12	97027-06030	BOLT	2				
13	92907-06600	WASHER, PLATE	2				
14	5GJ-12481-00	PIPE 1	1				
15	5GJ-12482-00	PIPE 2	1				
16	93210-21190	O-RING	3				
17	97027-06016	BOLT	2				
18	92907-06600	WASHER, PLATE	2				

5GJ1300-1050

FIG. 6 RADIATOR. HOSE

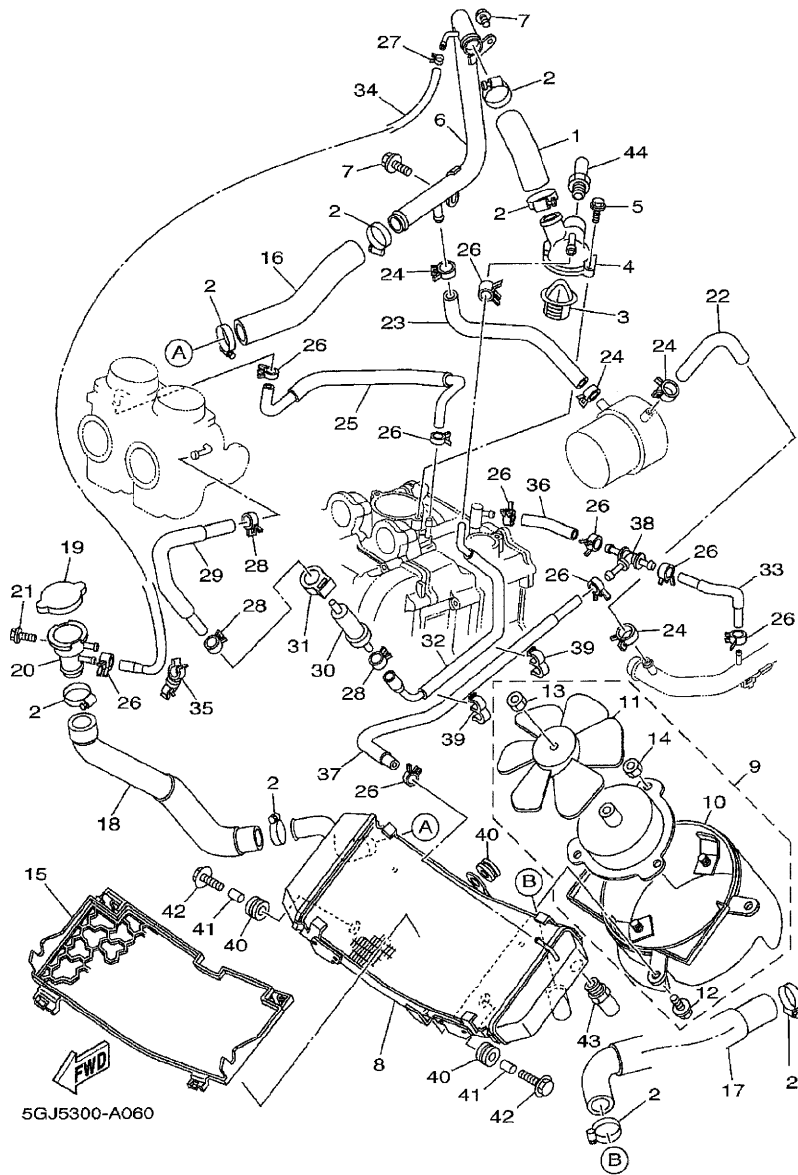

5GJ5300-A060

REF. NO.	PART NO.	DESCRIPTION	5GJ5				REMARKS
1	5GJ-12483-00	PIPE 3	1				
2	90450-32015	HOSE CLAMP ASSY	8				
3	46X-12410-00	THERMOSTAT ASSY	1				
4	5GJ-12413-10	COVER, THERMOSTAT	1				
5	95027-06025	BOLT, FLANGE	2				
6	5GJ-12484-00	PIPE 4	1				
7	95807-06010	BOLT, FLANGE	2				
8	5GJ-12461-00	RADIATOR ASSY	1				
9	5GJ-12405-00	BLOWER ASSY	1				
10	5GJ-12620-00	.AIR SHROUD ASSY	1				
11	5GJ-12611-00	.FAN	1				
12	5GJ-12675-00	.BOLT, BLOWER HOLDING	3				
13	95702-05500	.NUT, FLANGE	1				
14	95702-05500	.NUT, FLANGE	3				
15	5GJ-12467-00	COVER, RADIATOR	1				
16	5GJ-12485-00	PIPE 5	1				
17	5GJ-12476-00	PIPE 6	1				
18	5GJ-12477-00	PIPE 7	1				
19	4JH-12462-00	CAP, RADIATOR	1				
20	5GJ-12591-00	SUPT, FILLER NECK	1				
21	95807-06012	BOLT, FLANGE	1				
22	5GJ-1243A-00	HOSE 1	1				
23	5GJ-1243E-00	HOSE 2	1				
24	90467-15141	CLIP	4				
25	5GJ-1243F-00	HOSE,3	1				
26	90467-10035	CLIP	10				
27	90467-09120	CLIP	1				

FIG. 6 RADIATOR. HOSE

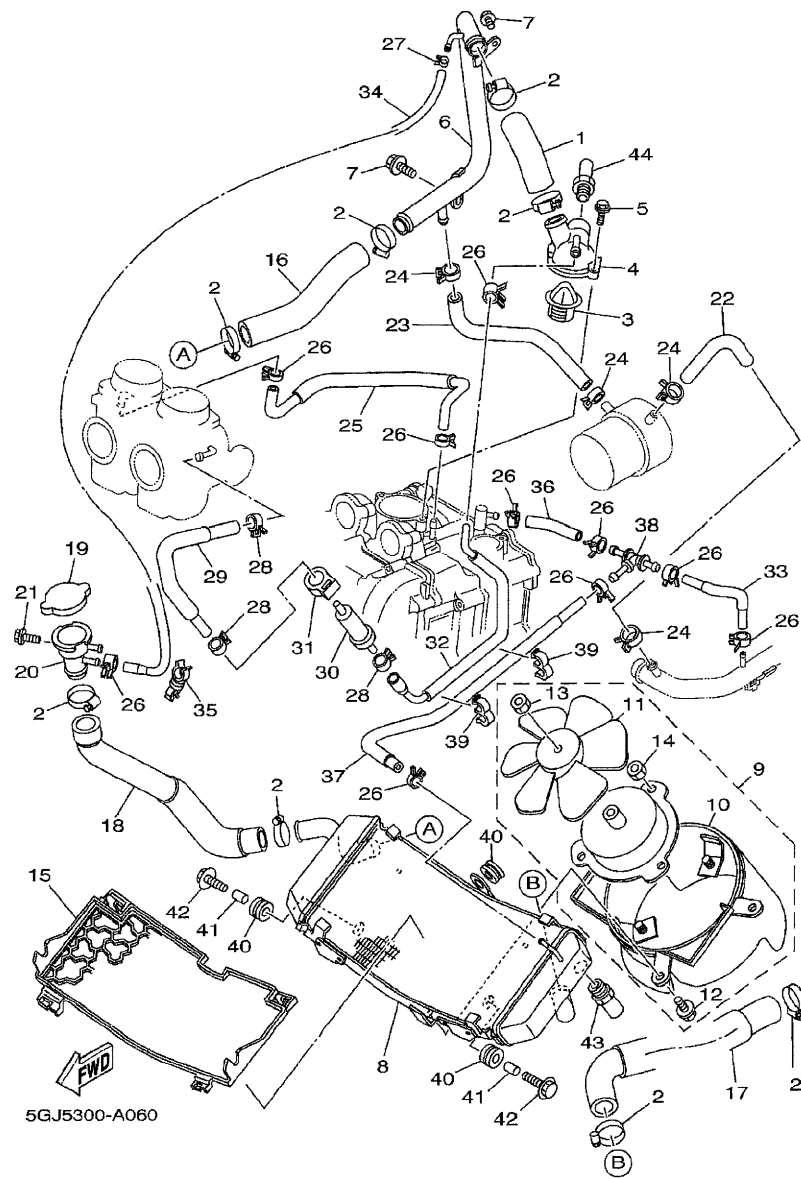

REF. NO.	PART NO.	DESCRIPTION	5GJ5	REMARKS
28	90467-12053	CLIP	3	
29	5GJ-1244G-00	HOSE, 4	1	
30	5AH-1240G-00	THERMOSTAT COVER ASSY	1	
31	5GJ-12491-00	CLAMP 1	1	
32	5GJ-12588-10	HOSE 5	1	
33	5GJ-12589-10	HOSE 6	1	
34	5GJ-12551-00	HOSE 7	1	
35	90464-13001	CLAMP	1	
36	5GJ-12552-10	HOSE 8	1	
37	5GJ-12576-10	HOSE 1	1	
38	90413-08012	WAY 3	1	
39	90464-12238	CLAMP	2	
40	90480-16301	GROMMET	3	
41	90387-0714B	COLLAR	2	
42	95807-06030	BOLT, FLANGE	2	
43	5GH-82560-00	THERMO SWITCH ASSY	1	
44	5GJ-82560-00	THERMO SWITCH ASSY	1	

FIG. 7 OIL PUMP

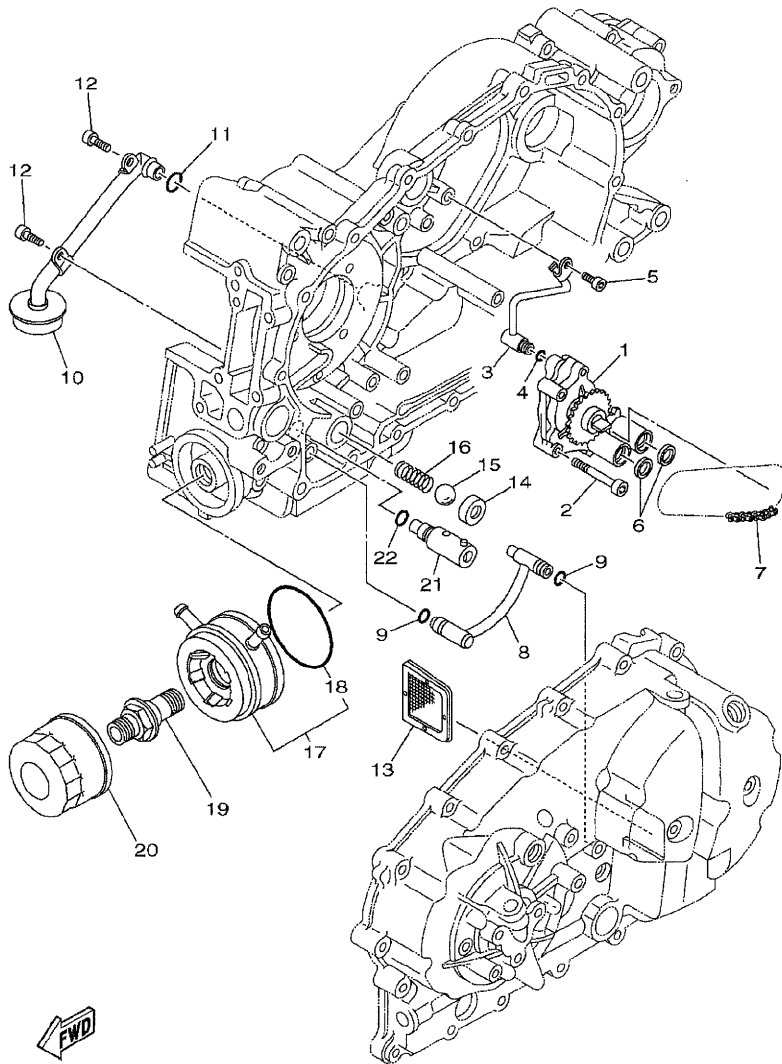

5GJ1300-1070

REF. NO.	PART NO.	DESCRIPTION	5GJ5				REMARKS
1	5GJ-13300-00	OIL PUMP ASSY	1				
2	92017-06050	BOLT, BUTTON HEAD	3				
3	5GJ-13161-00	PIPE, DELIVERY 1	1				
4	93210-06422	O-RING	1				
5	90110-06004	BOLT, HEXAGON SOCKET HEAD	1				
6	5GJ-13475-00	GASKET	2				
7	94580-25058	CHAIN (DID25 58L)	1				
8	5GJ-13405-00	OIL PIPE COMP. 1	1				
9	93210-09525	O-RING	2				
10	5GJ-13410-00	STRAINER HOUSING ASSY	1				
11	93210-14579	O-RING	1				
12	90110-06004	BOLT, HEXAGON SOCKET HEAD	2				
13	22F-13411-01	STRAINER, OIL	1				
14	3LD-13113-00	SEAT, CHECK BALL	1				
15	93505-08030	BALL	1				
16	90501-104F9	SPRING, COMPRESSION	1				
17	5GJ-13470-10	OIL COOLER ASSY	1				
18	4JH-13473-00	O-RING	1				
19	90401-20170	BOLT, UNION	1				
20	5DM-13440-00	ELEMENT ASSY, OIL CLEANER	1				
21	4GO-13490-01	RELIEF VALVE ASSY	1				
22	93210-10096	O-RING	1				

FIG. 8 INTAKE

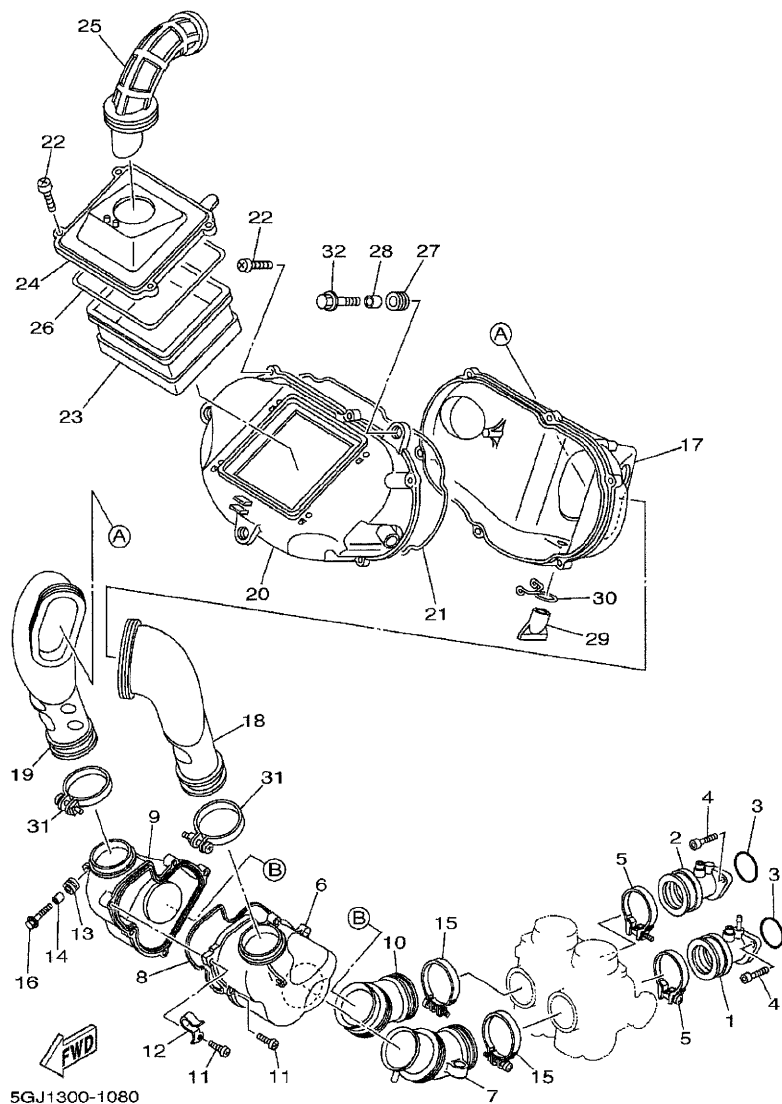

REF. NO.	PART NO.	DESCRIPTION	5GJ5				REMARKS
1	5GJ-13586-00	JOINT, CARBURETOR 1	1				
2	5GJ-13596-00	JOINT, CARBURETOR 2	1				
3	93210-32738	O-RING	2				
4	91317-06020	BOLT	4				
5	5GJ-13575-00	BAND	2				
6	5GJ-14431-00	SILENCER, INTAKE 1	1				
7	5GJ-14453-00	JOINT, AIR CLEANER 1	1				
8	1JK-14462-00	SEAL	1				
9	5GJ-14432-00	SILENCER, INNER	1				
10	5GJ-14463-00	JOINT, AIR CLEANER 2	1				
11	97707-50520	SCREW, TAPPING	5				
12	90465-08371	CLAMP	1				
13	90480-12497	GROMMET	2				
14	90387-067V1	COLLAR	2				
15	90460-56071	CLAMP, HOSE	2				
16	95807-06020	BOLT, FLANGE	2				
17	5GJ-14411-00	CASE, AIR CLEANER 1	1				
18	5GJ-1440F-00	JOINT, AIR FILTER 1	1				
19	5GJ-1440G-00	JOINT, AIR FILTER 2	1				
20	5GJ-1441A-00	COVER, CLEANER CASE 1	1				
21	4KN-14452-00	SEAL	1				
22	97707-50520	SCREW, TAPPING	10				
23	4BH-14451-00	ELEMENT, AIR CLEANER	1				
24	5GJ-14412-00	CAP, CLEANER CASE 1	1				
25	5GJ-14437-00	DUCT	1				
26	3KJ-14452-30	SEAL	1				
27	90480-12497	GROMMET	3				

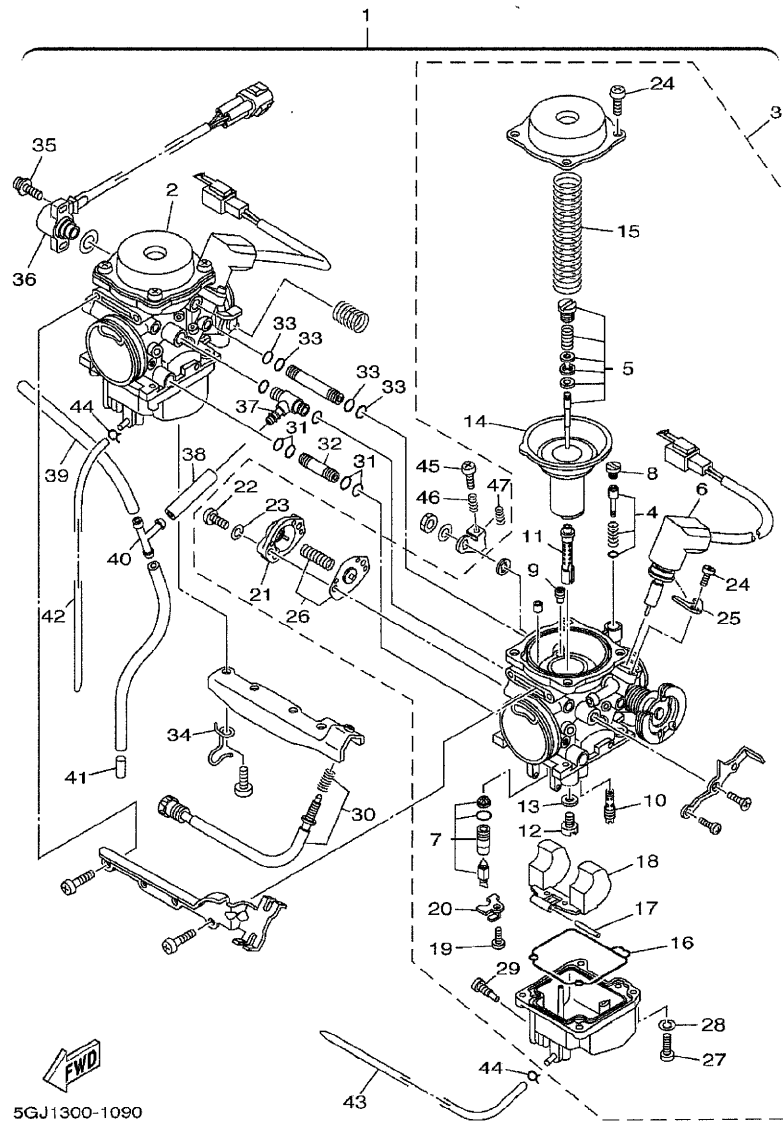
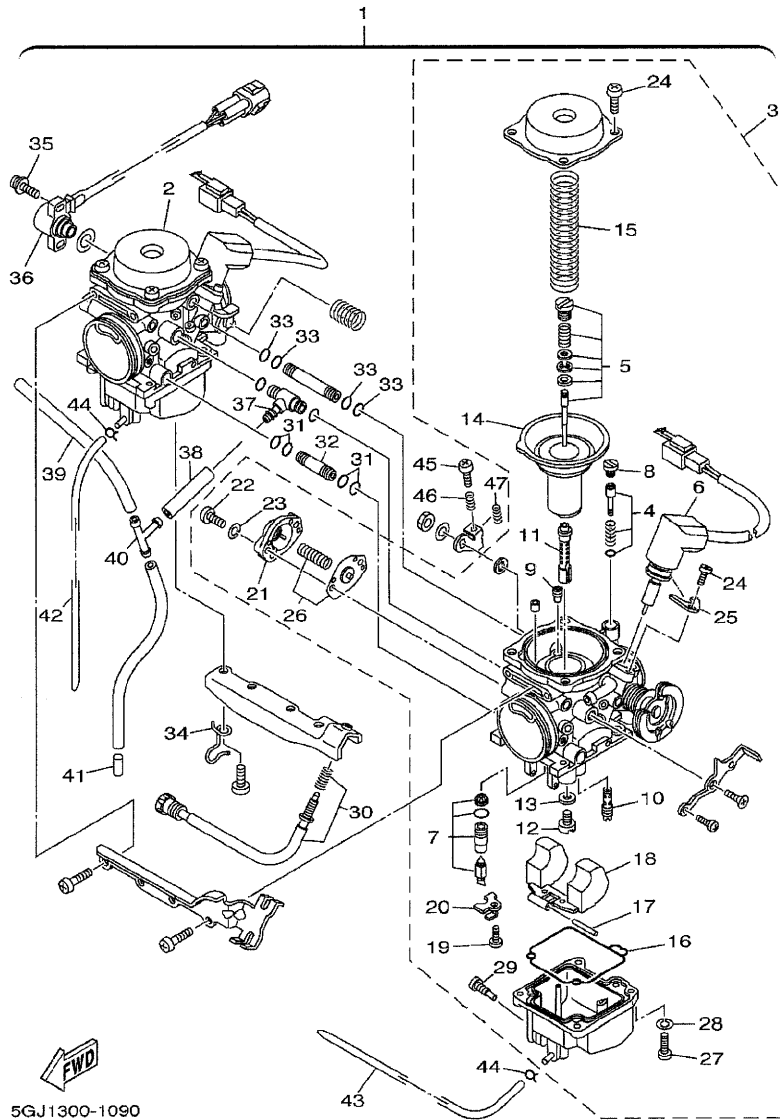

FIG. 9 CARBURETOR

REF. NO.	PART NO.	DESCRIPTION	5GJ15	REMARKS
1	5GJ-14900-20	CARBURETOR ASSY	1	
2	5GJ-14901-20	CARBURETOR ASSY 1	1	
3	5GJ-14902-20	CARBURETOR ASSY 2	1	
4	5GJ-14105-00	PILOT SCREW SET	1	
5	5GJ-1490J-00	NEEDLE SET	1	
6	5GJ-14993-00	PLUNGER, STARTER	1	
7	4HM-14107-20	NEEDLE VALVE SET	1	
8	22F-14991-00	CAP	1	
9	3G2-14231-17	JET, POWER (# 85)	1	
10	1NT-14142-22	JET, PILOT (# 22.5)	1	
11	5GJ-1414N-30	NOZZLE, MAIN	1	
12	620-1423A-71	JET, MAIN (#102.5)	1	
13	137-14153-00	WASHER, MAIN JET	1	
14	5GJ-24411-00	DIAPHRAGM	1	
15	4VR-14933-00	SPRING, DIAPHRAGM	1	
16	5GJ-14147-00	O-RING	1	
17	537-14186-00	PIN, FLOAT	1	
18	4G0-14985-00	FLOAT	1	
19	98507-04006	SCREW, PAN HEAD	1	
20	3UH-14945-00	PLATE	1	
21	5AP-14280-00	COVER, CARBURETOR	1	
22	98507-04014	SCREW, PAN HEAD	2	
23	92907-04100	WASHER, SPRING	2	
24	98507-05008	SCREW, PAN HEAD	5	
25	5GJ-14945-00	PLATE	1	
26	5EL-1490H-00	DIAPHRAGM SET 5	1	
27	98507-04012	SCREW, PAN HEAD	4	

FIG. 9 CARBURETOR



REF. NO.	PART NO.	DESCRIPTION	5GJ15				REMARKS
28	92907-04100	.WASHER, SPRING	4				
29	12R-14191-00	.PLUG, DRAIN	1				
30	5GJ-14103-00	.THROTTLE SCREW SET	1				
31	822-14147-00	.O-RING	4				
32	1WG-14251-00	.NIPPLE	1				
33	36Y-14147-00	.O-RING	4				
34	5GJ-14919-00	.CLIP	1				
35	4WM-14565-00	.SCREW	2				
36	4XY-85885-00	.THROTTLE SENSOR ASSY	1				
37	5GJ-14389-00	.NIPPLE ASSY	1				
38	5GJ-14197-00	.PIPE	1				
39	5GJ-14197-30	.PIPE	1				
40	3H3-24376-00	.PIPE, JOINT 1	1				
41	5GJ-14149-00	.PIPE	1				
42	5GJ-14348-00	.PIPE 1	1				
43	5GJ-14349-00	.PIPE	1				
44	14X-14937-00	.CLIP	2				
45	1WG-14922-00	.SCREW, THROTTLE	1				
46	1HX-14133-00	.SPRING, THROTTLE STOP	1				
47	620-14212-00	.SPRING, PILOT ADJUSTING	1				

FIG. 10 EXHAUST

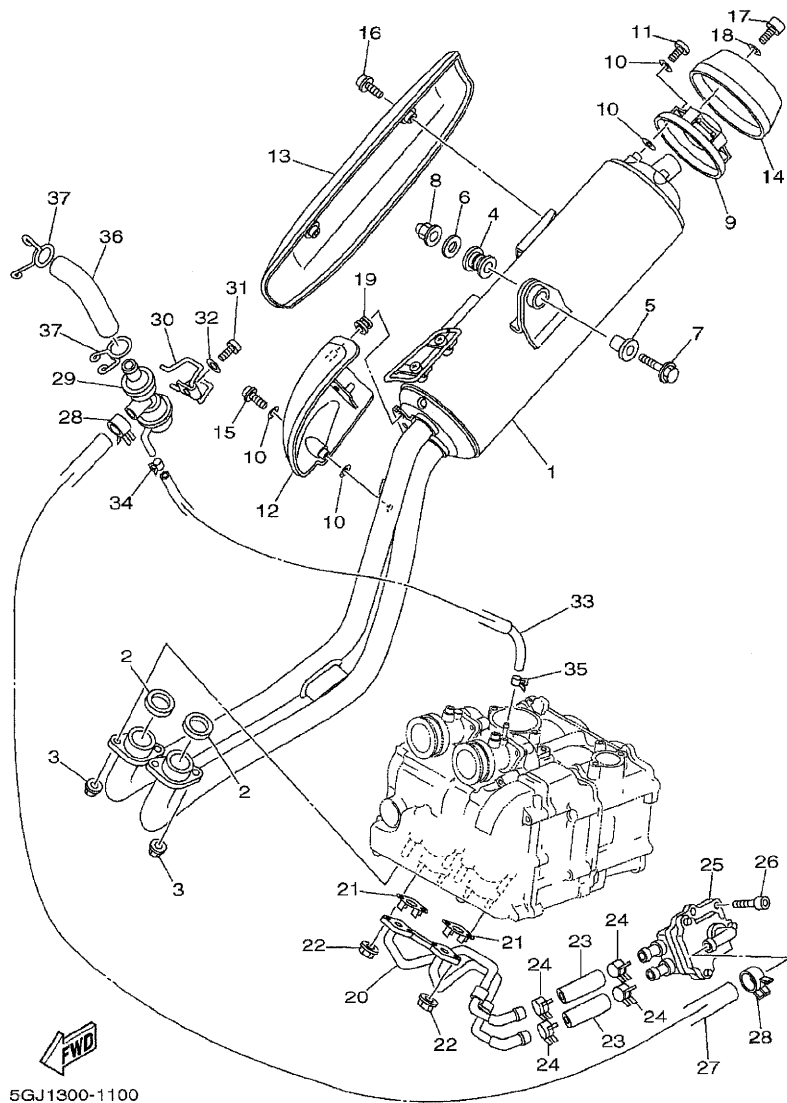

5GJ1300-1100

REF. NO.	PART NO.	DESCRIPTION	5GJ5				REMARKS
1	5GJ-14710-00	MUFFLER ASSY 1	1				
2	4BR-14613-00	GASKET, EXHAUST PIPE	2				
3	95607-08200	NUT, SELF-LOCKING	4				
4	36Y-27424-00	DAMPER, FOOTREST 2	1				
5	90387-10636	COLLAR	1				
6	90201-10669	WASHER, PLATE	1				
7	95807-10040	BOLT, FLANGE	1				
8	90176-10075	NUT, CROWN	1				
9	5GJ-14629-00	STAY, PROTECTOR	1				
10	4BD-14766-00	WASHER, PROTECTOR	8				
11	98980-06010	SCREW, BIND	3				
12	5GJ-1465R-00	PLATE, PROTECTOR	1				
13	5GJ-1465T-00	PLATE, PROTECTOR	1				
14	5GJ-14799-00	CAP	1				
15	90111-06020	BOLT	1				
16	90111-06015	BOLT	2				
17	91380-06016	BOLT	5				
18	92990-06200	WASHER, PLAIN	5				
19	90480-10332	GROMMET	2				
20	5GJ-14871-00	PIPE 1	1				
21	5GJ-14815-00	GASKET	2				
22	95707-06500	NUT, FLANGE	4				
23	5GJ-14873-01	PIPE 3	2				
24	90467-19065	CLIP	4				
25	5GJ-14808-00	REED VALVE ASSY	1				
26	91317-06010	BOLT	3				
27	5GJ-14875-00	PIPE 5	1				

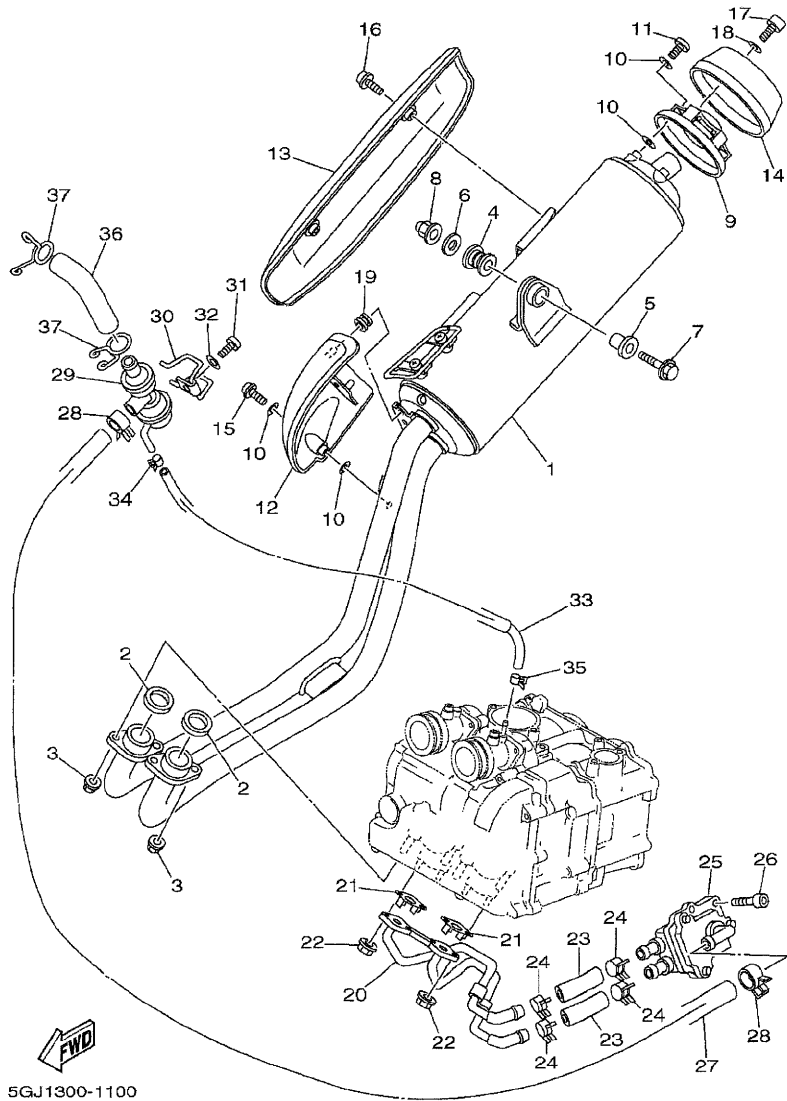

5GJ1300-1100

FIG. 10 EXHAUST

REF. NO.	PART NO.	DESCRIPTION	5GJ15				REMARKS
28	90467-19160	CLIP	2				
29	1TA-14840-00	AIR CUT VALVE ASS'Y	1				
30	90462-20188	CLAMP	1				
31	98507-06014	SCREW, PAN HEAD	1				
32	92907-06600	WASHER, PLATE	1				
33	5GJ-13542-00	HOSE, VACUUM SENSING 1	1				
34	90467-07138	CLIP	1				
35	90467-08092	CLIP	1				
36	5GJ-14876-00	PIPE 6	1				
37	90467-24096	CLIP	2				

FIG. 11 CRANKCASE

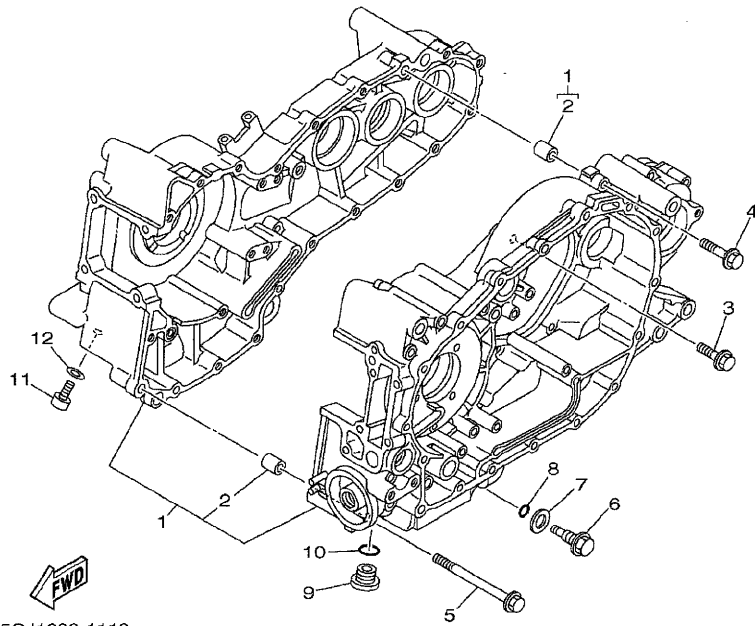
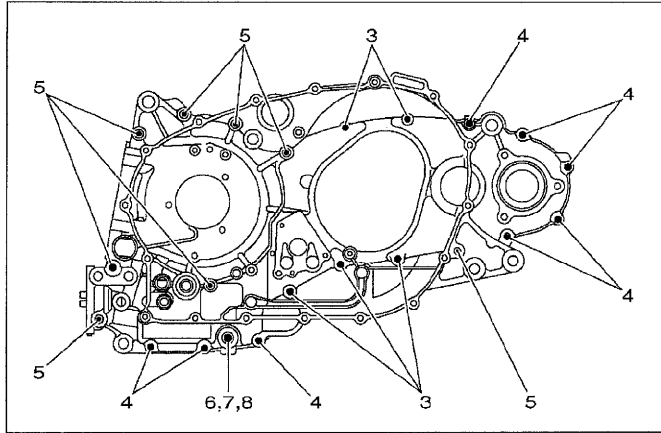

5GJ1300-1110

REF. NO.	PART NO.	DESCRIPTION	5GJ5				REMARKS
1	5GJ-15100-00	CRANKCASE ASSY	1				
2	99530-10114	.PIN, DOWEL	2				
3	95027-06035	BOLT, FLANGE	5				
4	95027-06050	BOLT, FLANGE	8				
5	95027-08110	BOLT, FLANGE	8				
6	5GJ-15481-00	BOLT 1	1				
7	214-11198-01	GASKET	1				
8	93210-48364	O-RING	1				
9	4H7-15189-00	PLUG	1				
10	93210-22382	O-RING	1				
11	90110-08004	BOLT, HEXAGON SOCKET HEAD	1				
12	90430-08119	GASKET	1				

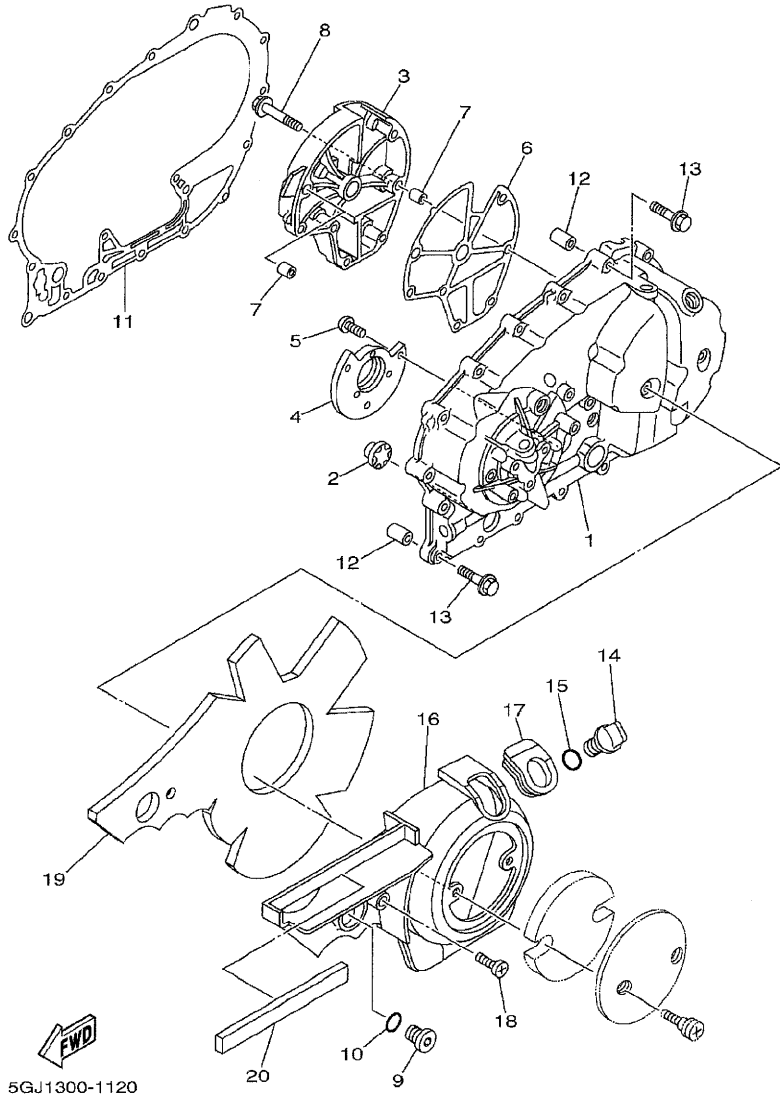
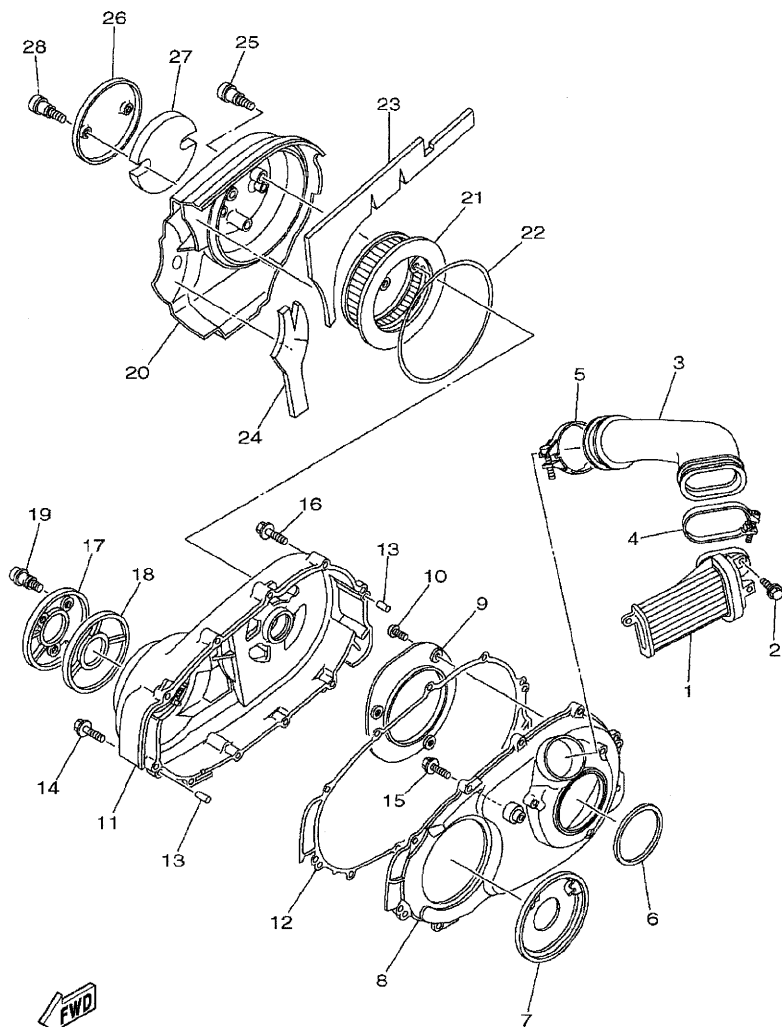

FIG. 12 CRANKCASE COVER 1

REF. NO.	PART NO.	DESCRIPTION	5GJ5				REMARKS
1	5GJ-15411-00	COVER, CRANKCASE 1	1				
2	2H7-15361-00	GAUGE, LEVEL	1				
3	5GJ-15414-00	COVER, AIR CLEANER	1				
4	5GJ-15417-00	COVER, CAP	1				
5	90149-06020	SCREW	3				
6	5GJ-15453-00	GASKET	1				
7	99530-10114	PIN, DOWEL	2				
8	95027-06035	BOLT, FLANGE	7				
9	36Y-15189-00	PLUG	1				
10	93210-16325	O-RING	1				
11	5GJ-15451-00	GASKET, CRANKCASE COVER 1	1				
12	99530-10114	PIN, DOWEL	2				
13	95027-06035	BOLT, FLANGE	19				
14	5GJ-15363-00	PLUG, OIL	1				
15	93210-19123	O-RING	1				
16	5GJ-15415-00	COVER, GENERATOR	1				
17	5GJ-15486-00	GROMMET	1				
18	3KJ-15481-00	BOLT 1	1				
19	5GJ-15316-00	DAMPER, ENGINE MOUNT 1	1				
20	5GJ-15337-00	DAMPER 4	1				

FIG. 13 CRANKCASE COVER 2



5GJ1300-1130

REF. NO.	PART NO.	DESCRIPTION	5GJ5				REMARKS
1	5GJ-15407-00	ELEMENT 1	1				
2	90119-06192	BOLT, WITH WASHER	2				
3	5GJ-15473-00	DUCT, AIR	1				
4	5GJ-14455-00	BAND	1				
5	5GJ-14456-00	BAND	1				
6	5GJ-15474-00	SEAL, AIR DUCT	1				
7	5GJ-15191-00	PLATE	1				
8	5GJ-15431-00	COVER, CRANKCASE 3	1				
9	5GJ-15113-00	PLATE	1				
10	92017-06014	BOLT, BUTTON HEAD	3				
11	5GJ-15421-00	COVER, CRANKCASE 2	1				
12	5GJ-15461-00	GASKET, CRANKCASE COVER 2	1				
13	99480-08020	PIN	2				
14	95027-08040	BOLT, FLANGE	6				
15	95027-08025	BOLT, FLANGE	2				
16	95027-06035	BOLT, FLANGE	4				
17	5GJ-15492-00	COVER	1				
18	5GJ-1542A-00	DAMPER 1	1				
19	3KJ-15481-00	BOLT 1	3				
20	5GJ-15423-00	COVER 2	1				
21	5GJ-15408-00	ELEMENT 2	1				
22	48U-14452-00	SEAL	1				
23	5GJ-15326-00	DAMPER, ENGINE MOUNT 2	1				
24	5GJ-1542B-00	DAMPER 2	1				
25	3KJ-15481-00	BOLT 1	3				
26	5GJ-15499-00	PROTECTOR, COVER	2				
27	5GJ-15789-00	DAMPER	2				

FIG. 14 STARTER

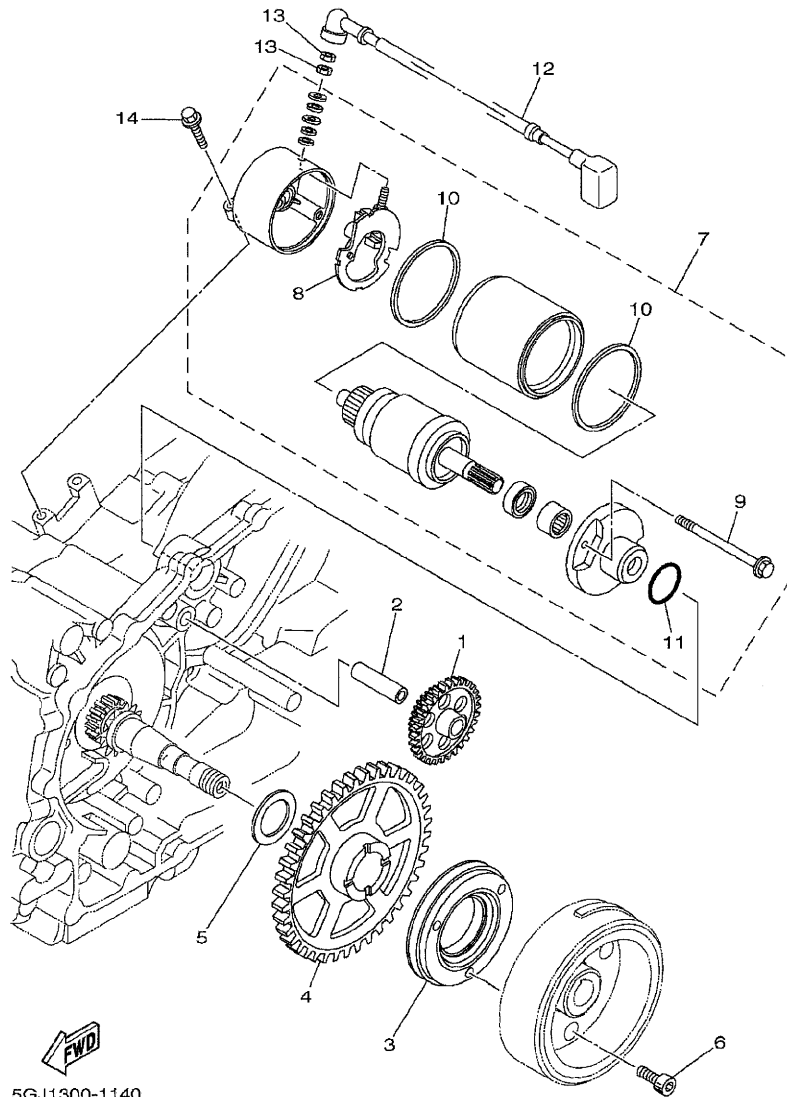

5GJ1300-1140

REF. NO.	PART NO.	DESCRIPTION	5GJ15				REMARKS
1	5GJ-15512-00	GEAR, IDLER 1	1				
2	36Y-15521-01	SHAFT 1	1				
3	4NK-15590-00	STARTER ONE-WAY ASSY	1				
4	5GJ-15517-00	GEAR, IDLER 2	1				
5	90201-25290	WASHER, PLATE	1				
6	90110-08005	BOLT, HEXAGON SOCKET HEAD	3				
7	5GJ-81890-00	MOTOR ASSY	1				
8	3HE-81840-00	.BRUSH HOLDER ASSY	1				
9	3HE-81826-00	.BOLT	2				
10	11H-81844-00	.GASKET	2				
11	1FK-81847-00	.O-RING	2				
12	5GJ-81815-00	CORD, STARTER MOTOR	1				
13	4XV-8182A-00	NUT	2				
14	95817-06025	BOLT, FLANGE	2				

FIG. 15 CLUTCH

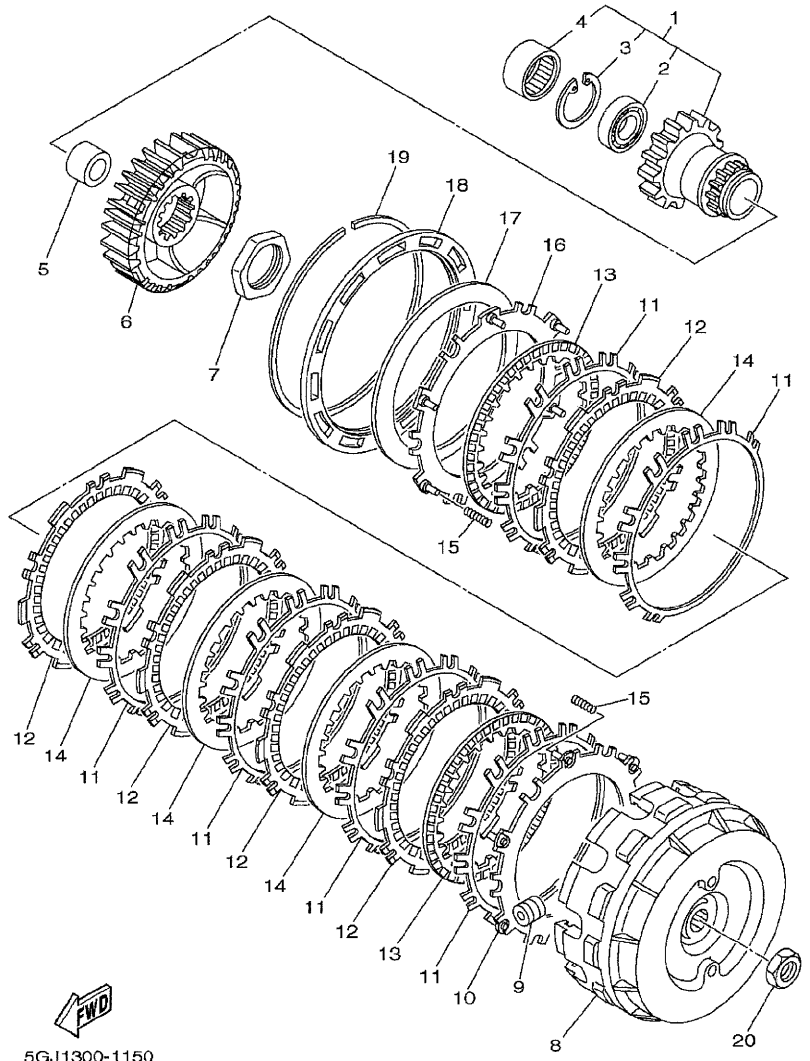

5GJ1300-1150

REF. NO.	PART NO.	DESCRIPTION	5GJ15	REMARKS
1	5GJ-16110-00	PRIMARY DRIVE GEAR ASSY	1	
2	93306-90403	.BEARING	1	
3	99009-37500	.CIRCLIP	1	
4	93317-33179	.BEARING	1	
5	90387-1904J	COLLAR	1	
6	5GJ-16371-00	BOSS, CLUTCH	1	
7	90170-36279	NUT	1	
8	5GJ-16510-10	CLUTCH HOUSING COMP.	1	
9	5GJ-16540-00	ROLLER WEIGHT ASSY	12	
10	5GJ-16520-00	PLATE, THRUST WEIGHT	1	
11	5GJ-16533-00	SPRING, CLUTCH	6	
12	5GJ-16321-00	PLATE, FRICTION	5	
13	5GJ-16325-00	PLATE, CLUTCH 2	2	
14	5GJ-16324-00	PLATE, CLUTCH 1	4	
15	5GJ-16539-10	SPRING	6	
16	5GJ-16550-00	PRESSURE PLATE ASSY	1	
17	5GJ-16334-00	SPRING, CLUTCH 2	1	
18	5GJ-16537-00	PLATE, SPRING STOPPER	1	UR
	5GJ-16537-10	PLATE, SPRING STOPPER	1	UR
	5GJ-16537-20	PLATE, SPRING STOPPER	1	UR
	5GJ-16537-30	PLATE, SPRING STOPPER	1	UR
19	5GJ-16529-00	CLIP	1	
20	90170-16326	NUT	1	

ATT: JP

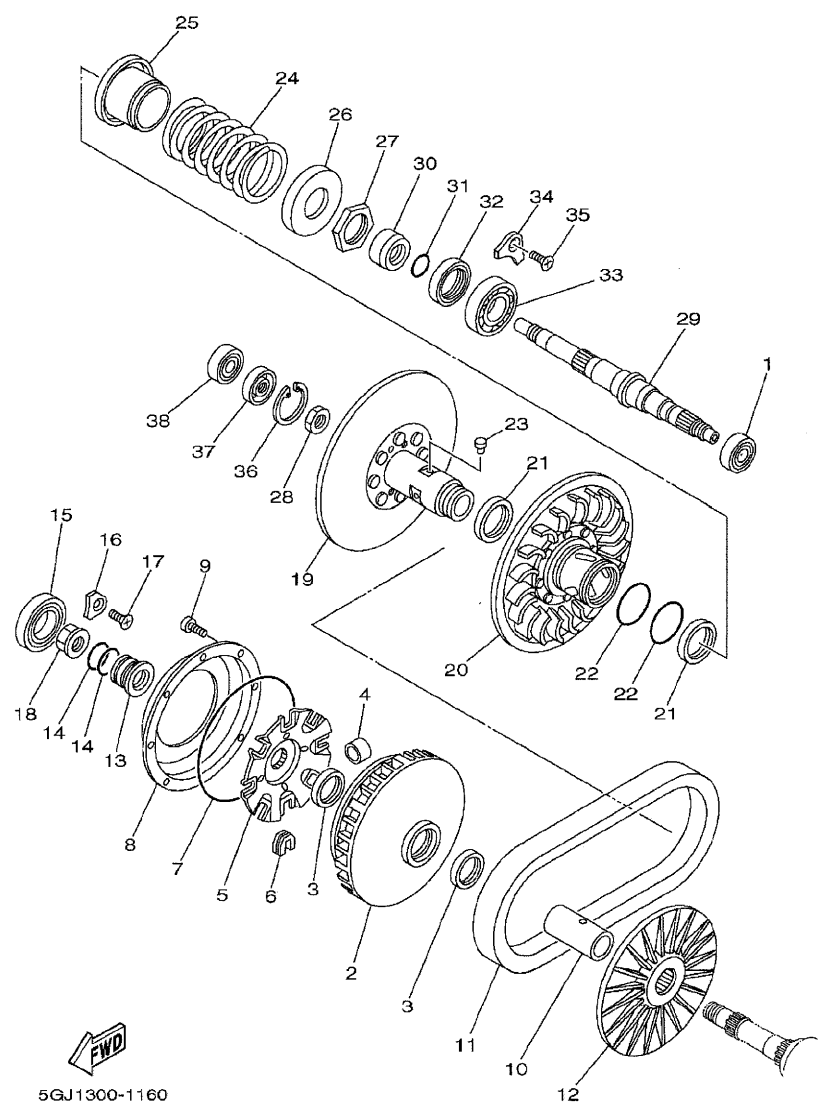

5GJ1300-1160

FIG. 16 CLUTCH 2

REF. NO.	PART NO.	DESCRIPTION	5GJ15				REMARKS
1	93306-30102	BEARING (B6301)	1				
2	5GJ-17620-00	PRIMARY SLIDING SHEAVE COMP.	1				
3	93101-35001	OIL SEAL	2				
4	5GJ-17632-00	WEIGHT	8				
5	5GJ-17623-00	CAM	1				
6	5GJ-17653-00	SLIDER	8				
7	93211-44348	O-RING	1				
8	5GJ-17639-00	STOPPER	1				
9	90111-05012	BOLT	8				
10	5GJ-17645-00	COLLAR	1				
11	5GJ-17641-00	V-BELT	1				
12	5GJ-17611-00	SHEAVE, PRIMARY FIXED	1				
13	5GJ-17649-00	SPACER	1				
14	93210-30611	O-RING	2				
15	93306-00708	BEARING	1				
16	4XM-15383-00	PLATE, BEARING COVER	1				
17	90151-06001	SCREW, COUNTERSUNK	1				
18	90179-20002	NUT	1				
19	5GJ-17660-00	SECONDARY FIXED SHEAVE COMP.	1				
20	5GJ-17670-00	SECONDARY SLIDING SHEAVE	1				
21	93104-41119	OIL SEAL	2				
22	93210-44545	O-RING	2				
23	4CW-17664-00	PIN, GUIDE	4				
24	90501-626L9	SPRING, COMPRESSION	1				
25	5GJ-17690-00	SPRING SEAT COMP.	1				
26	4WV-17644-00	SEAT, SPRING	1				
27	90170-36279	NUT	1				

C10

FIG. 16 CLUTCH 2

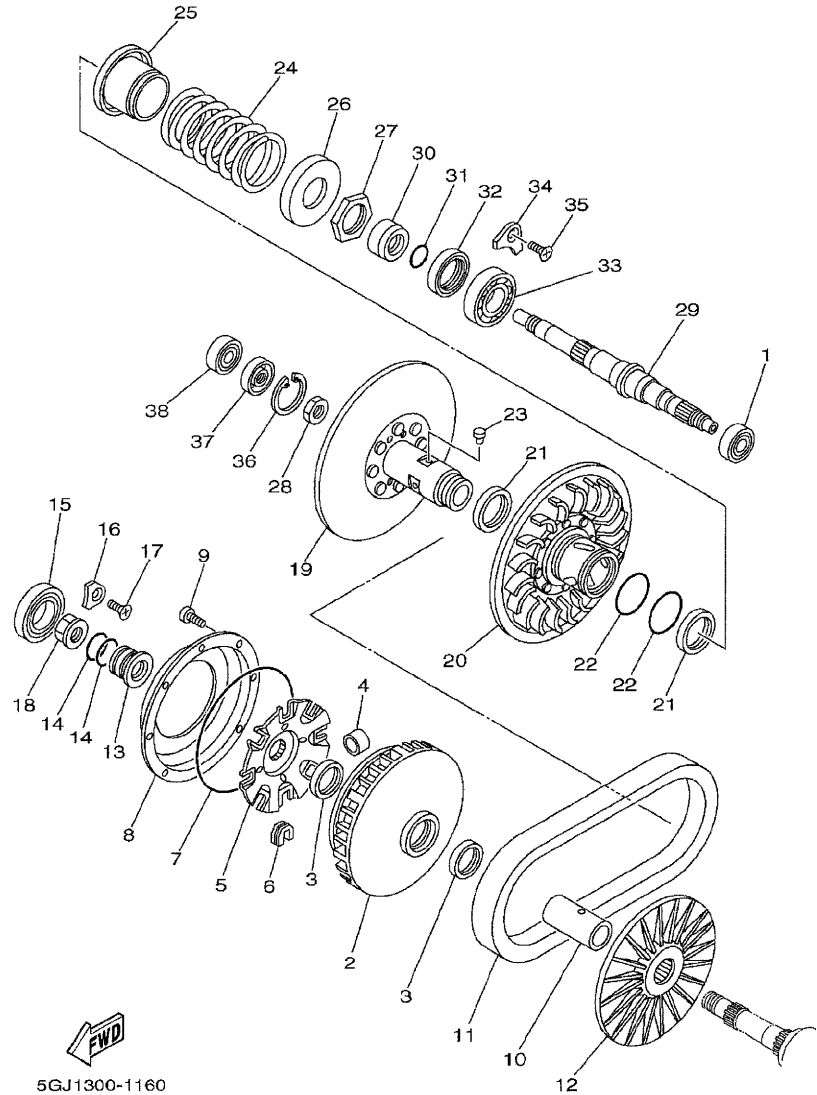

5GJ1300-1160

REF. NO.	PART NO.	DESCRIPTION	5GJ15	REMARKS
28	90170-18221	NUT	1	
29	5GJ-17681-00	SHAFT, SECONDARY	1	
30	90387-26001	COLLAR	1	
31	93210-26001	O-RING	1	
32	93102-42004	OIL SEAL	1	
33	93306-20647	BEARING	1	
34	5GJ-15383-00	PLATE, BEARING COVER	1	
35	90110-06036	BOLT, HEXAGON SOCKET HEAD	1	
36	99009-42500	CIRCLIP	1	
37	93102-15004	OIL SEAL	1	
38	93306-30206	BEARING (B6302ZZ)	1	

FIG. 17 TRANSMISSION

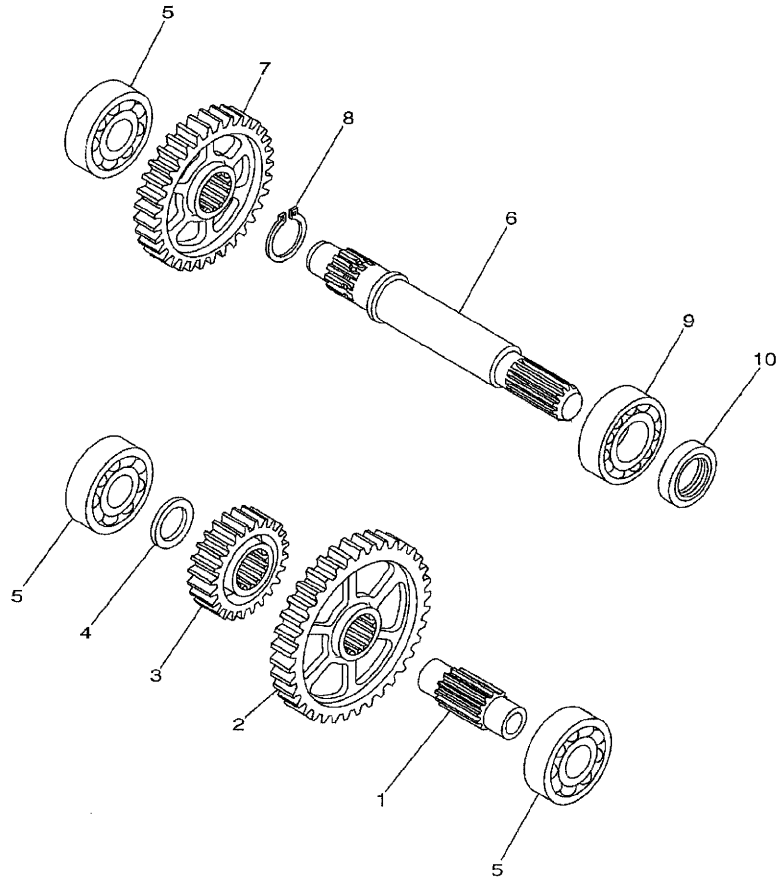

REF. NO.	PART NO.	DESCRIPTION	5GJ15	REMARKS
1	5GJ-17411-00	AXLE, MAIN	1	
2	5GJ-16151-00	GEAR, PRIMARY DRIVEN (24T)	1	
3	5GJ-17111-00	GEAR, 1ST PINION (22T)	1	
4	90201-20272	WASHER, PLATE	1	
5	93306-30401	BEARING (B6304)	3	
6	5GJ-17421-00	AXLE, DRIVE	1	
7	5GJ-17211-00	GEAR, 1ST WHEEL (34T)	1	
8	99009-25400	CIRCLIP	1	
9	93306-20583	BEARING	1	
10	93102-25064	OIL SEAL	1	



5GJ1300-1170

FIG. 18 SUB TRANSMISSION

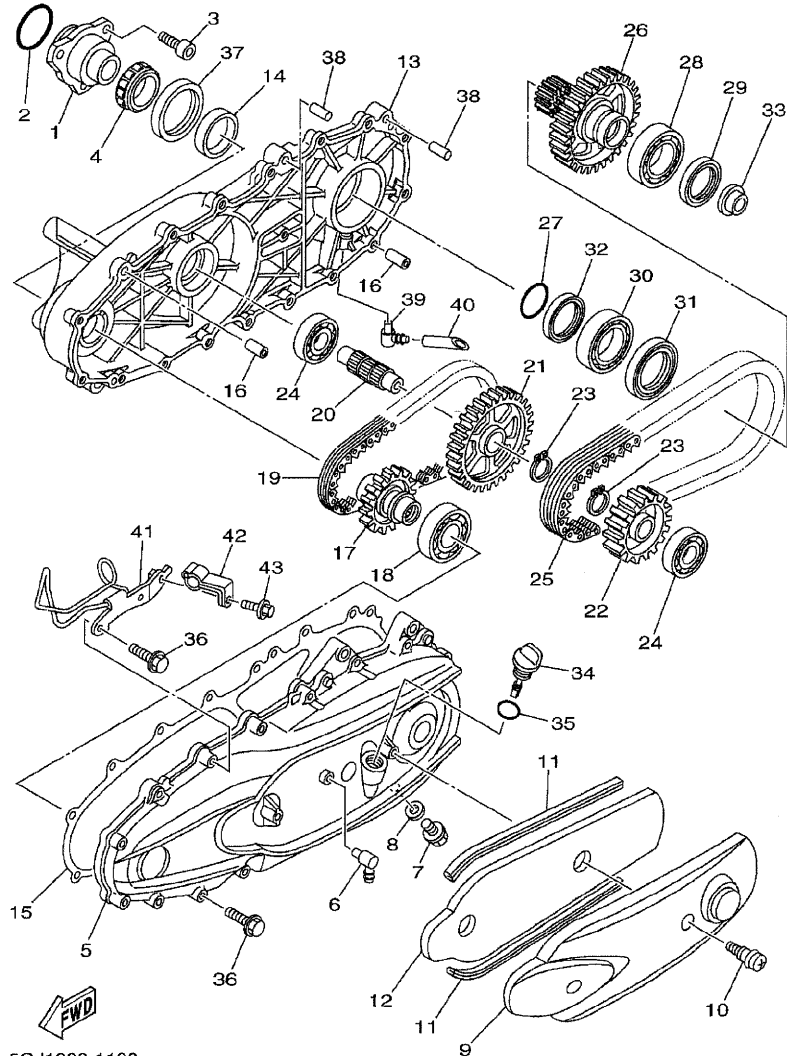

5GJ1300-1180

REF. NO.	PART NO.	DESCRIPTION	5GJ5				REMARKS
1	5GJ-17524-00	HOLDER	1				
2	93210-50553	O-RING	1				
3	91317-08020	BOLT	3				
4	93332-00086	BEARING	1				
5	5GJ-17541-00	CASE, TRANSFER 1	1				
6	4HC-15371-00	BREATHER	1				
7	90340-12059	PLUG, STRAIGHT SCREW	1				
8	812-11198-00	GASKET	1				
9	5GJ-15418-00	COVER, CHAIN CASE	1				
10	3KJ-15481-00	BOLT 1	2				
11	5GJ-15335-00	DAMPER 3	2				
12	5GJ-15338-00	DAMPER, ENGINE MOUNT 5	1				
13	5GJ-17542-00	CASE, TRANSFER 2	1				
14	5GJ-17554-00	RETAINER, BEARING	1				
15	5GJ-17818-01	GASKET	1				
16	99530-10114	PIN, DOWEL	2				
17	5GJ-17451-00	SPROCKET, DRIVE	1				
18	93306-20637	BEARING	1				
19	5GJ-16139-00	CHAIN, PRIMARY	1				
20	5GJ-17523-00	SHAFT	1				
21	5GJ-17452-00	SPROCKET, DRIVE	1				
22	5GJ-17459-00	SPROCKET, DRIVE	1				
23	99009-25400	CIRCLIP	2				
24	93306-30401	BEARING (B6304)	2				
25	5GJ-11456-00	CHAIN, PRIMARY	1				
26	5GJ-17469-00	SPROCKET, DRIVE	1				
27	93210-34504	O-RING	1				

FIG. 18 SUB TRANSMISSION

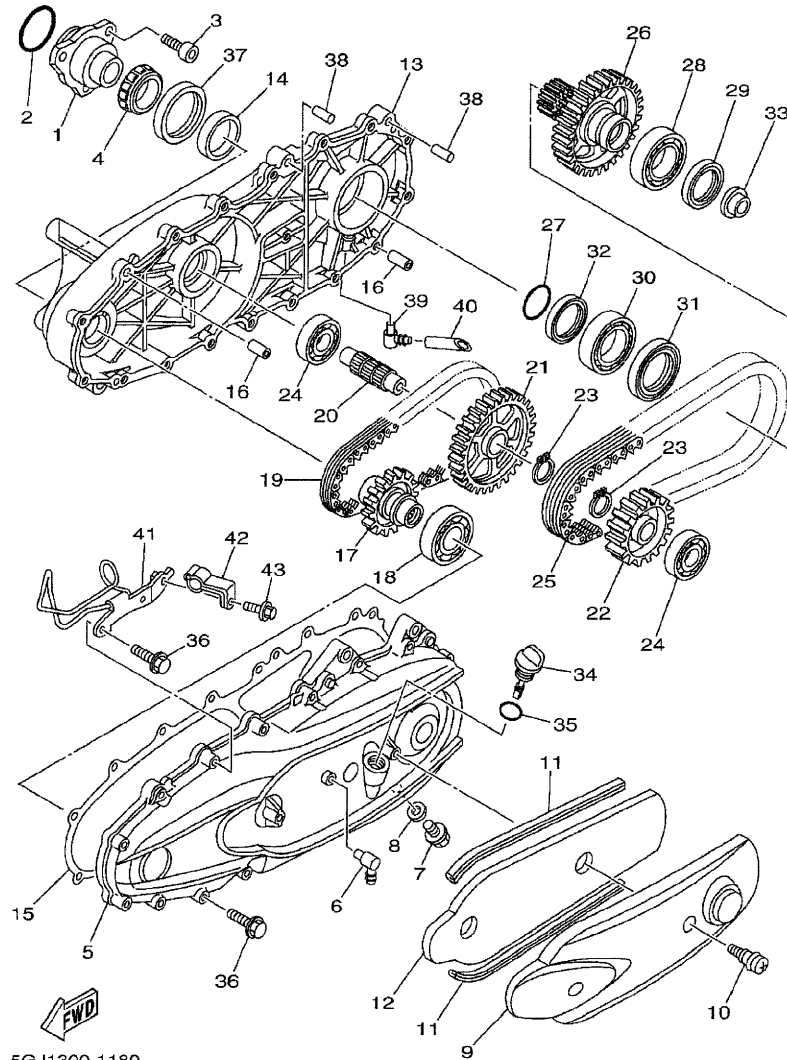

5GJ1300-1180

REF. NO.	PART NO.	DESCRIPTION	5GJ15				REMARKS
28	93306-00803	BEARING (B6008)	1				
29	93102-40080	OIL SEAL	1				
30	93306-00804	BEARING	1				
31	93102-48004	OIL SEAL	1				
32	93105-45017	OIL SEAL	1				
33	5GJ-46153-00	COLLAR, GUIDE	1				
34	5GJ-15362-01	PLUG, OIL LEVEL	1				
35	93210-19123	O-RING	1				
36	95024-06035	BOLT, FLANGE	18				
37	93102-55004	OIL SEAL	1				
38	93608-30152	PIN, DOWEL	2				
39	3ES-15371-00	BREATHER	1				
40	5GJ-1531A-00	HOSE, BREATHER 1	1				
41	5GJ-2587A-00	HOLDER, BREAK HOSE	1				
42	5GJ-2587A-10	HOLDER, BREAK HOSE	1				
43	95807-06010	BOLT, FLANGE	1				

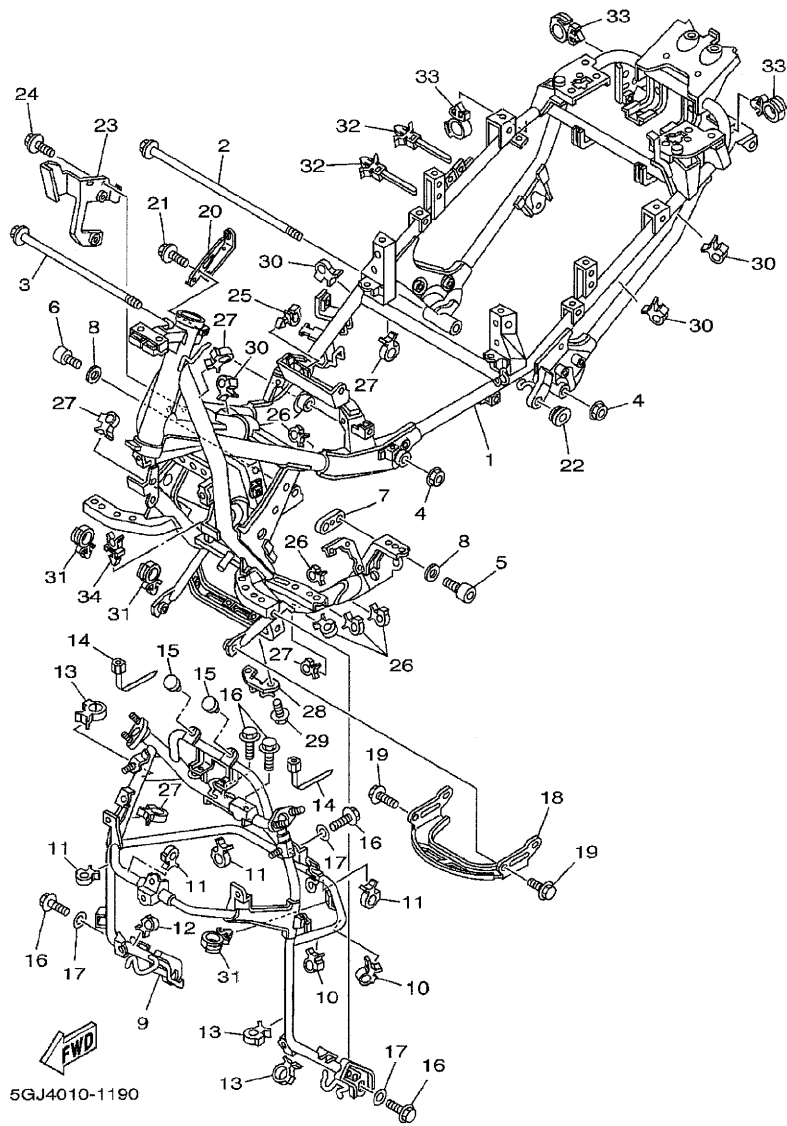
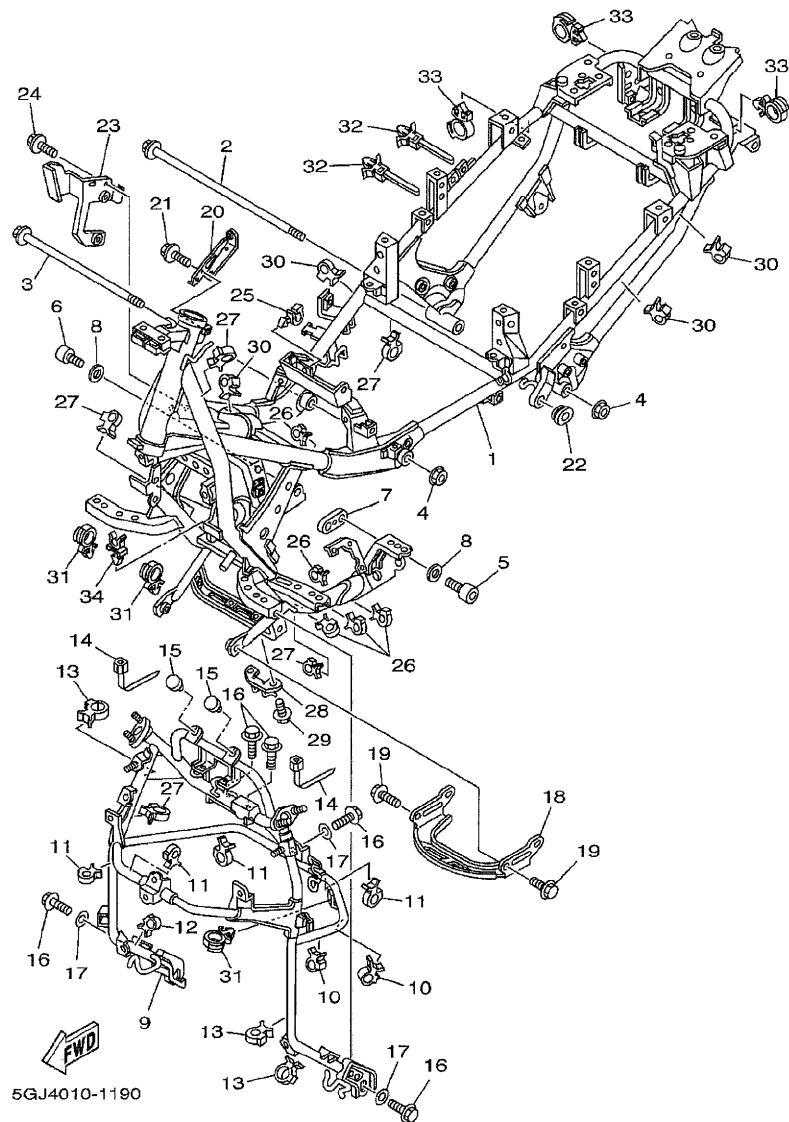

FIG. 19 FRAME

REF. NO.	PART NO.	DESCRIPTION	5GJ5				REMARKS
1	5GJ-21110-00	FRAME COMP.	1				
2	90105-12106	BOLT, FLANGE	1				
3	90105-12760	BOLT, FLANGE	1				
4	95607-12200	NUT, SELF-LOCKING	2				
5	91317-10045	BOLT	2				
6	91317-10030	BOLT	2				
7	5GJ-21459-00	SPACER	1				
8	90201-10430	WASHER, PLATE	4				
* 9	5GJ-28356-10	STAY 1	1				
10	90464-08189	CLAMP	2				
11	90464-10190	CLAMP	4				
12	90464-15192	CLAMP	1				
13	90464-25217	CLAMP	3				
14	90464-13077	CLAMP	2				
15	116-27114-00	STOPPER, MAIN STAND	2				
16	95807-08016	BOLT, FLANGE	5				
17	90201-087F0	WASHER, PLATE	3				
18	5GJ-2117G-00	PROTECTOR	1				
19	95807-06012	BOLT, FLANGE	2				
20	5GJ-2832F-00	STAY, LEG SHIELD 3	1				
21	95807-06010	BOLT, FLANGE	1				
22	90480-01558	GROMMET	1				
23	5GJ-82316-00	BRACKET, IGNITION COIL	1				
24	95807-06010	BOLT, FLANGE	2				
25	90464-07001	CLAMP	1				
26	90464-08189	CLAMP	5				
27	90464-15192	CLAMP	5				

FIG. 19 FRAME



REF. NO.	PART NO.	DESCRIPTION	5GJ5	REMARKS
28	5GJ-21587-00	STAY 1	1	
29	95807-06010	BOLT, FLANGE	2	
30	90464-10190	CLAMP	4	
31	90464-13249	CLAMP	5	
32	90464-12089	CLAMP	2	
33	90464-18246	CLAMP	3	
34	90464-09008	CLAMP	1	

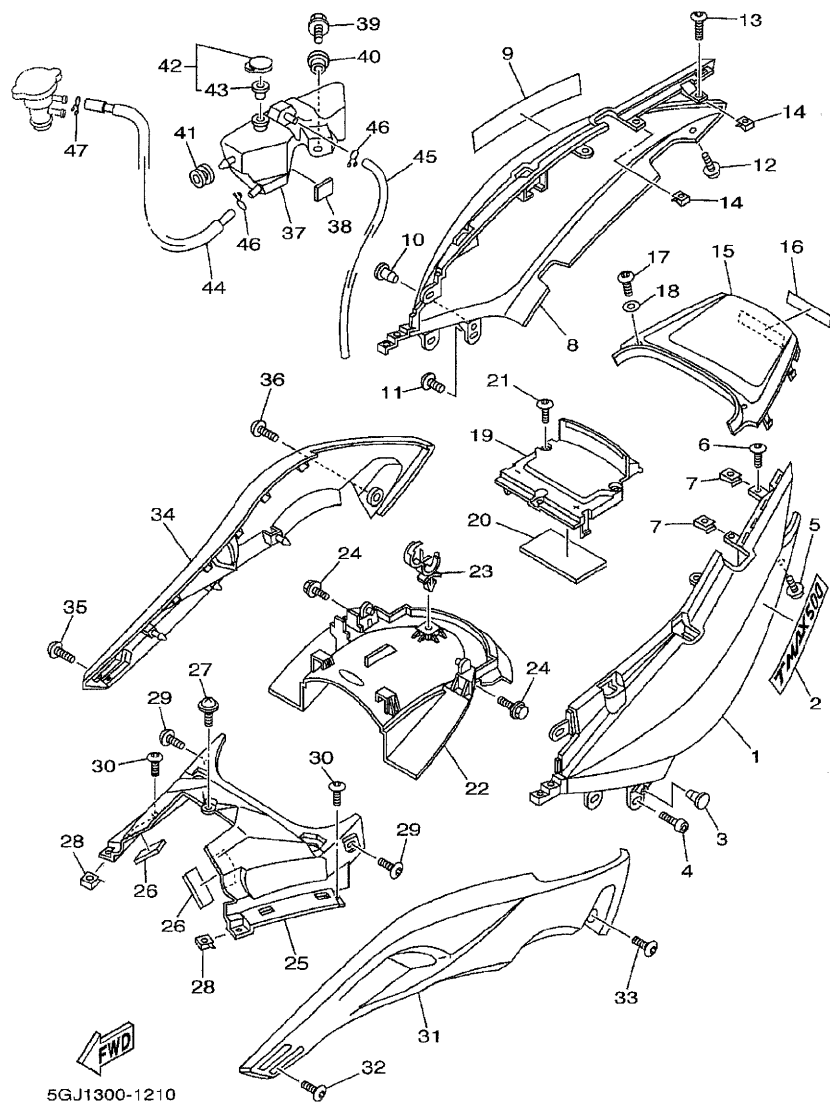
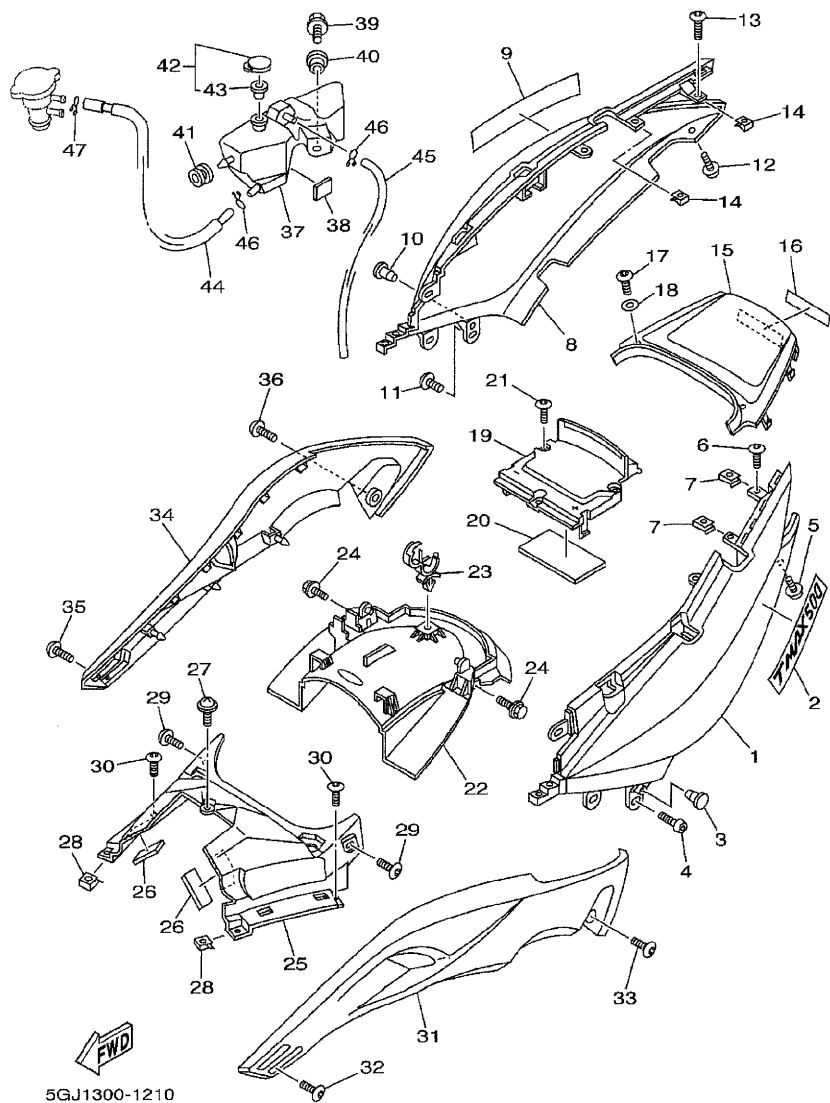

FIG. 21 SIDE COVER

REF. NO.	PART NO.	DESCRIPTION	5GJ15	REMARKS
1	5GJ-21711-00-AL	COVER, SIDE 1	1	UR CMY
2	5GJ-2173B-00	EMBLEM	1	
3	90338-06143	PLUG	1	
4	90110-06200	BOLT, HEXAGON SOCKET HEAD	2	
5	90167-05076	SCREW, TAPPING	1	
6	90167-05079	SCREW, TAPPING	1	
7	90183-05042	NUT, SPRING	2	
8	5GJ-21721-00-AL	COVER, SIDE 2	1	UR CMY
9	5GJ-2173B-00	EMBLEM	1	
10	90338-06143	PLUG	1	
11	90110-06200	BOLT, HEXAGON SOCKET HEAD	2	
12	90167-05076	SCREW, TAPPING	1	
13	90167-05079	SCREW, TAPPING	1	
14	90183-05042	NUT, SPRING	2	
15	5GJ-21741-00-AL	COVER, SIDE 4	1	UR CMY
16	99247-00080	EMBLEM, YAMAHA	1	
17	90167-05076	SCREW, TAPPING	2	
18	90209-05347	WASHER	2	



5GJ1300-1210

FIG. 21 SIDE COVER

REF. NO.	PART NO.	DESCRIPTION	5GJ15			REMARKS
19	5GJ-21716-00	LID, SIDE COVER	1			
20	5GJ-24724-00	DAMPER, SEAT	1			
21	98907-05020	SCREW, BIND	3			
22	5GJ-21629-00	GUARD, MUD	1			
23	90464-07209	CLAMP	1			
24	90119-06060	BOLT, WITH WASHER	2			
25	5GJ-21731-00	COVER, SIDE 3	1			
26	5GJ-21717-00	DAMPER	2			
27	90111-05002	BOLT	1			
28	90183-05042	NUT, SPRING	2			
29	90167-05080	SCREW, TAPPING	2			
30	90167-05079	SCREW, TAPPING	2			
31	5GJ-2171X-00-P0	COVER, SIDE 6	1			SM1
32	90167-05076	SCREW, TAPPING	2			
33	90110-06200	BOLT, HEXAGON SOCKET HEAD	1			
34	5GJ-2172W-00-P0	COVER	1			SM1
35	90167-05076	SCREW, TAPPING	2			
36	90110-06200	BOLT, HEXAGON SOCKET HEAD	1			
37	5GJ-21871-00	TANK, RECOVERY	1			
38	5GJ-24723-00	DAMPER, SEAT	1			
39	95807-06014	BOLT, FLANGE	1			
40	90387-066R8	COLLAR	1			
41	90480-13426	GROMMET	1			
42	1AA-21815-00	CAP	1			
43	1AA-21874-00	.GASKET	1			
44	5GJ-21816-00	PIPE 1	1			
45	90445-09094	HOSE (L210)	1			

FIG. 21 SIDE COVER

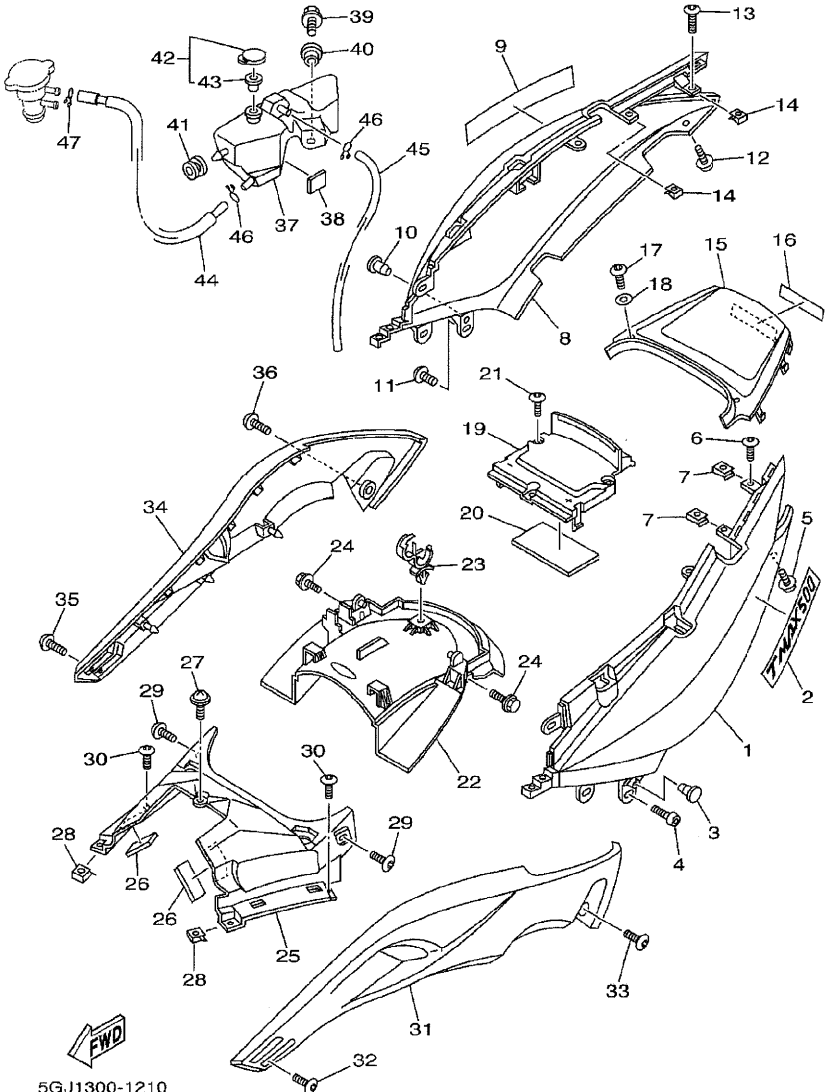

5GJ1300-1210

REF. NO.	PART NO.	DESCRIPTION	5GJ1300-1210	REMARKS
46	90467-08003	CLIP	2	
47	90467-10008	CLIP	1	

FIG. 22 REAR ARM. SUSPENSION

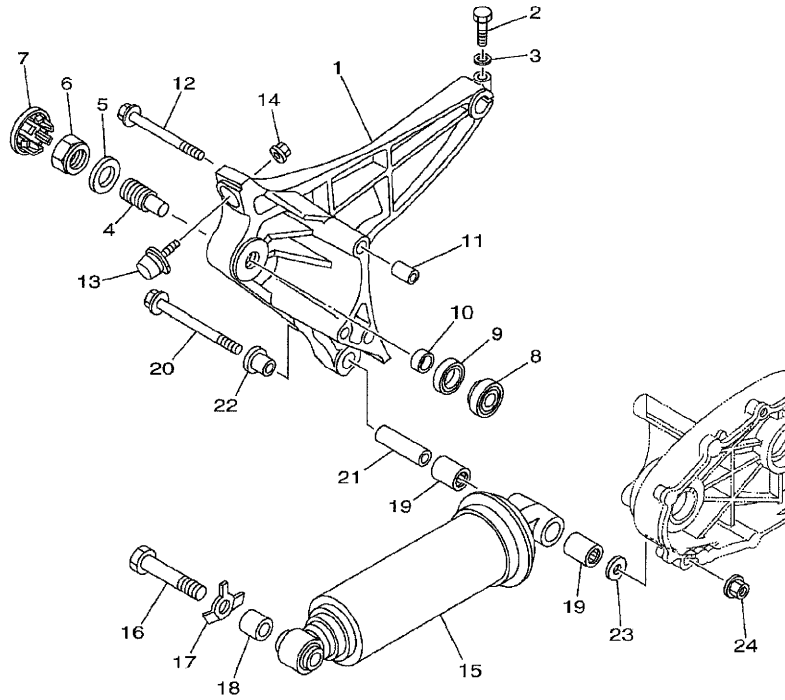

REF. NO.	PART NO.	DESCRIPTION	5GJ15				REMARKS
1	5GJ-22171-00-35	ARM, REAR 1	1				SL
2	97007-08035	BOLT	1				
3	92907-08600	WASHER, PLATE	1				
4	1J7-22141-00	SHAFT, PIVOT	1				
5	90201-220T0	WASHER, PLATE	1				
6	1J7-22143-00	NUT	1				
7	4BH-2219X-00	COVER	1				
8	93332-00010	BEARING	1				
9	93102-25017	OIL SEAL	1				
10	90387-17543	COLLAR	1				
11	99530-14016	PIN, DOWEL	2				
12	95817-10100	BOLT, FLANGE	3				
13	5GJ-22426-00	BUMP, STOP	1				
14	95607-06200	NUT, SELF U-FLANGE	1				
15	5GJ-22210-20	SHOCK ABSORBER ASSY, REAR	1				
16	90101-16002	BOLT	1				
17	5GJ-22243-00	WASHER 1	1				
18	90387-16008	COLLAR	1				
19	93317-41761	BEARING	2				
20	90105-12007	BOLT, FLANGE	1				
21	90387-12003	COLLAR	1				
22	90381-12047	BUSH, SOLID	1				
23	90201-122F8	WASHER, PLATE	1				
24	95607-12200	NUT, SELF-LOCKING	1				



5GJ1300-1220

FIG. 23 STEERING

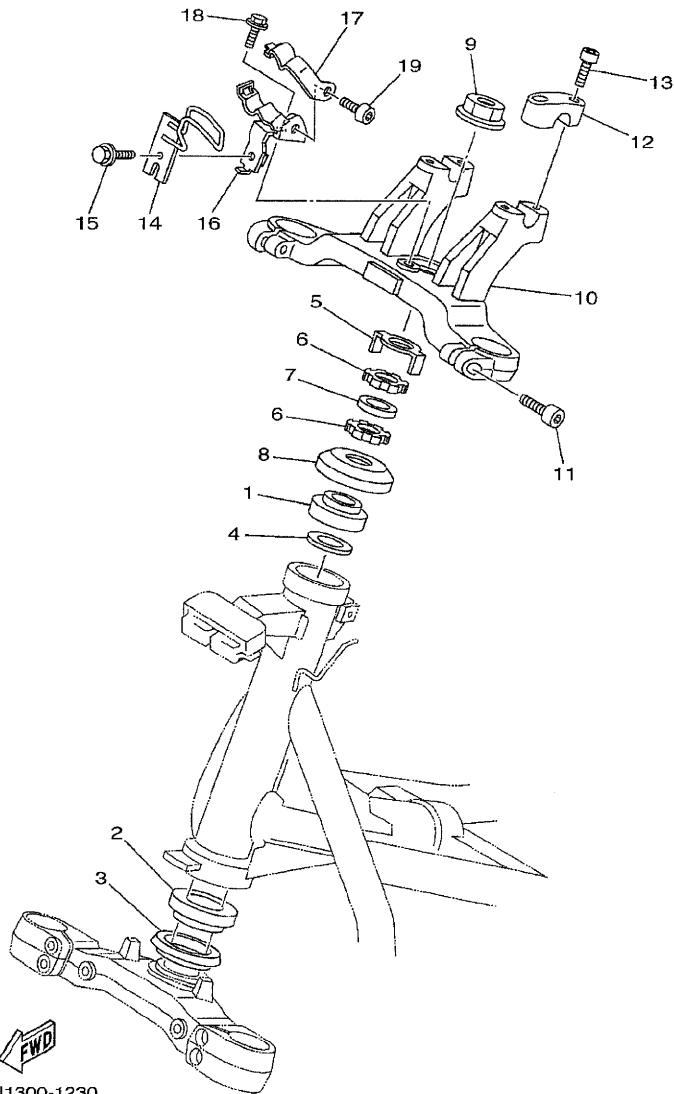

REF. NO.	PART NO.	DESCRIPTION	5GJ5	REMARKS
1	93399-99931	BEARING	1	
2	93399-99932	BEARING	1	
3	3FV-23462-00	SEAL, STEERING	1	
4	90202-24190	WASHER, PLATE	1	
5	26H-23418-01	WASHER, SPECIAL	1	
6	90179-25033	NUT	2	
7	90202-26142	WASHER, PLATE	1	
8	1W1-23416-00	COVER, BALL RACE 2	1	
9	90179-22412	NUT	1	
10	5GJ-23435-00	CROWN, HANDLE	1	
11	91317-08030	BOLT	2	
12	4H7-23441-10	HOLDER, HANDLE UPPER	2	
13	91317-08030	BOLT	4	
14	5GJ-2331E-00	GUIDE, CABLE	1	
15	95807-06012	BOLT, FLANGE	1	
16	5GJ-25886-00	HOLDER, BRAKE HOSE	1	
17	5GJ-25887-00	HOLDER, BRAKE HOSE	1	
18	95807-06010	BOLT, FLANGE	1	
19	92017-06012	BOLT, BUTTON HEAD	1	

5GJ1300-1230

FIG. 24 FRONT FORK

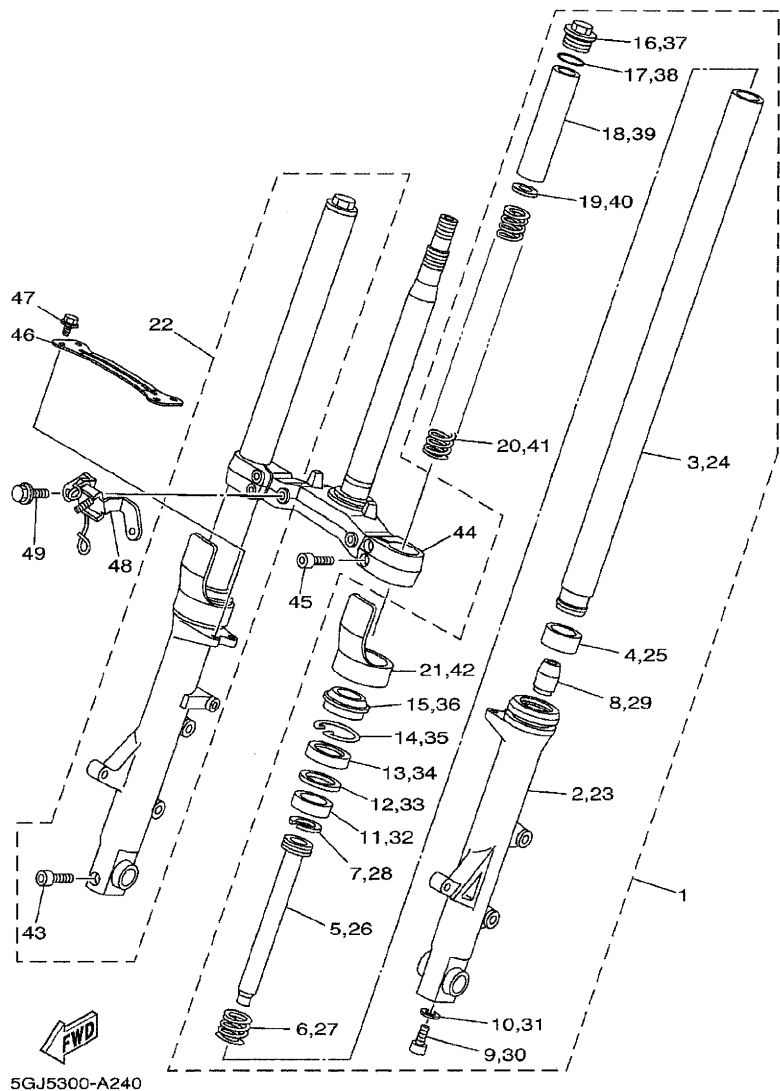

REF. NO.	PART NO.	DESCRIPTION	5GJ5				REMARKS
1	5GJ-23102-20	FRONT FORK ASSY (L.H)	1				
2	5GJ-23126-20	.TUBE, OUTER (LEFT)	1				
3	5GJ-23110-00	.INNER TUBE COMP.1	1				
4	3XC-23135-00	.METAL, SLIDE 2	1				
5	5GJ-23171-00	.PISTON, FRONT FORK	1				
6	3LN-23151-00	.SPRING, REBOUND	1				
7	3LN-23157-00	.RING, PISTON	1				
8	3LN-23173-00	.SPINDLE, TAPER	1				
9	90110-08N51	.BOLT, HEXAGON SOCKET HEAD	1				
10	90201-081E6	.WASHER, PLATE	1				
11	3XC-23125-00	.METAL, SLIDE 1	1				
12	1UF-23115-00	.GUIDE, COVER UPPER	1				
13	5GJ-23145-00	.OIL SEAL	1				
14	1UF-23156-00	.CLIP, OIL SEAL	1				
15	5GJ-23144-00	.SEAL, DUST	1				
16	3LN-23111-00	.BOLT, CAP	1				
17	93210-30694	.O-RING	1				
18	3LN-23118-00	.SPACER	1				
19	3LN-23142-00	.SEAT, SPRING UPPER	1				
20	5GJ-23141-00	.SPRING, FRONT FORK	1				
21	5GJ-2331G-00	.COVER	1				
22	5GJ-23103-20	FRONT FORK ASSY (R.H)	1				
23	5GJ-23136-20	.TUBE, OUTER (RIGHT)	1				
24	5GJ-23110-00	.INNER TUBE COMP.1	1				
25	3XC-23135-00	.METAL, SLIDE 2	1				
26	5GJ-23171-00	.PISTON, FRONT FORK	1				
27	3LN-23151-00	.SPRING, REBOUND	1				

FIG. 24 FRONT FORK

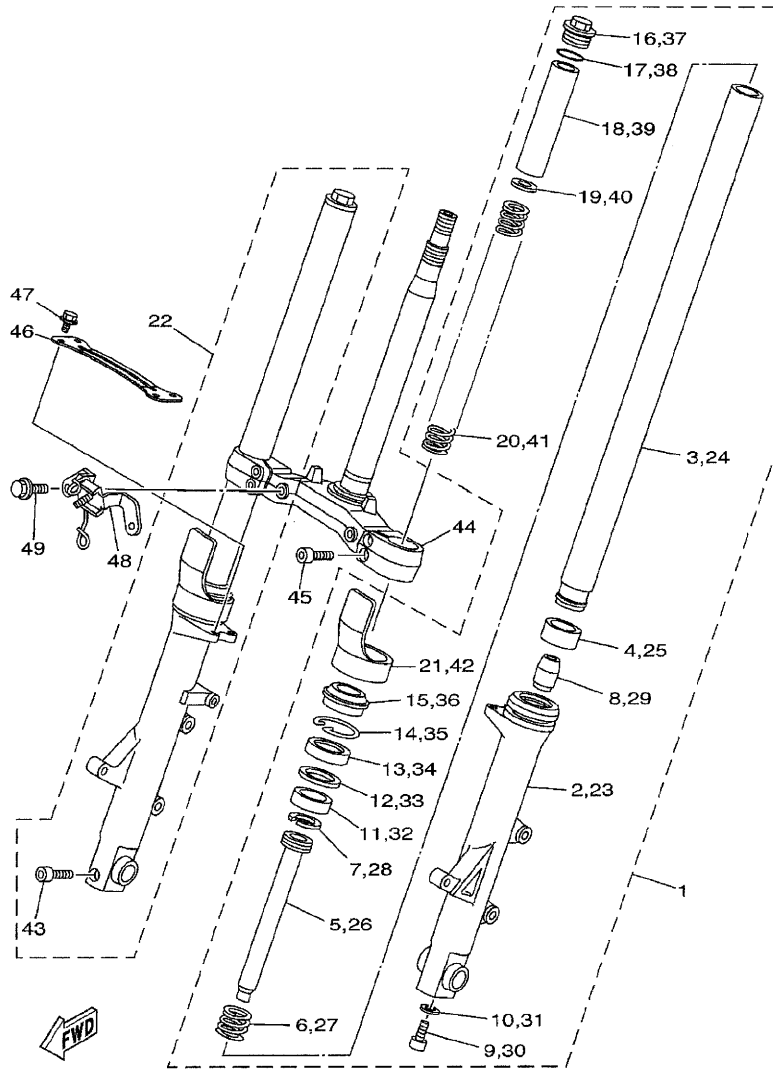

5GJ5300-A240

REF. NO.	PART NO.	DESCRIPTION	5GJ5				REMARKS
28	3LN-23157-00	.RING, PISTON	1				
29	3LN-23173-00	.SPINDLE, TAPER	1				
30	90110-08N51	.BOLT, HEXAGON SOCKET HEAD	1				
31	90201-081E6	.WASHER, PLATE	1				
32	3XC-23125-00	.METAL, SLIDE 1	1				
33	1UF-23115-00	.GUIDE, COVER UPPER	1				
34	5GJ-23145-00	.OIL SEAL	1				
35	1UF-23156-00	.CLIP, OIL SEAL	1				
36	5GJ-23144-00	.SEAL, DUST	1				
37	3LN-23111-00	.BOLT, CAP	1				
38	93210-30694	.O-RING	1				
39	3LN-23118-00	.SPACER	1				
40	3LN-23142-00	.SEAT, SPRING UPPER	1				
41	5GJ-23141-00	.SPRING, FRONT FORK	1				
42	5GJ-2331G-00	.COVER	1				
43	91317-08040	.BOLT	1				
44	5GJ-23340-00	UNDER BRACKET COMP.	1				
45	91317-08025	BOLT	4				
46	5GJ-21512-00	BRACKET, FENDER	1				
47	90105-06690	BOLT, FLANGE	4				
48	5GJ-23377-00	BRACKET, HORN	1				
49	95807-06010	BOLT, FLANGE	2				

FIG. 25 FUEL TANK

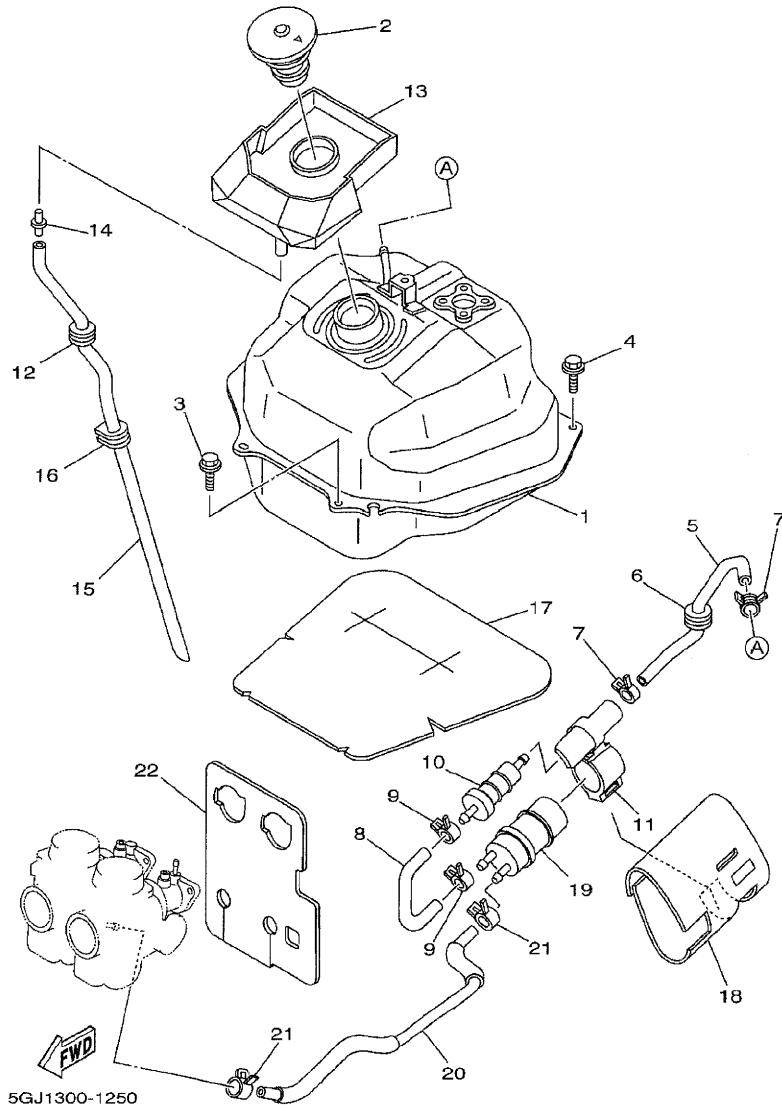

REF. NO.	PART NO.	DESCRIPTION	5GJ5				REMARKS
1	5GJ-24110-00	FUEL TANK COMP.	1				
2	3KJ-24602-03	CAP ASSY	1				
3	95827-06012	BOLT, FLANGE	2				
4	90119-06194	BOLT, WITH WASHER	2				
5	5GJ-24311-00	PIPE, FUEL 1	1				
6	90480-20527	GROMMET	1				
7	90467-12053	CLIP	2				
8	5GJ-24312-00	PIPE 2	1				
9	90467-12053	CLIP	2				
10	1FK-24560-10	FILTER ASSY	1				
11	5GJ-24398-00	BAND 1	1				
12	90480-13018	GROMMET	1				
13	5GJ-2414A-01	COVER, FILLER	1				
14	4JP-21753-00	BOSS, CONNECTOR	1				
15	5GJ-24318-00	PIPE, OVERFLOW	1				
16	90480-20280	GROMMET	1				
17	5GJ-24145-00	DAMPER, SIDE COVER	1				
18	5GJ-2414H-01	DAMPER, PLATE 1	1				
19	3LN-13907-00	FUEL PUMP COMP.	1				
20	5GJ-14294-00	HOSE	1				
21	90467-13062	CLIP	2				
22	5GJ-12682-00	PROTECTOR, HEAT	1				

FIG. 26 SEAT

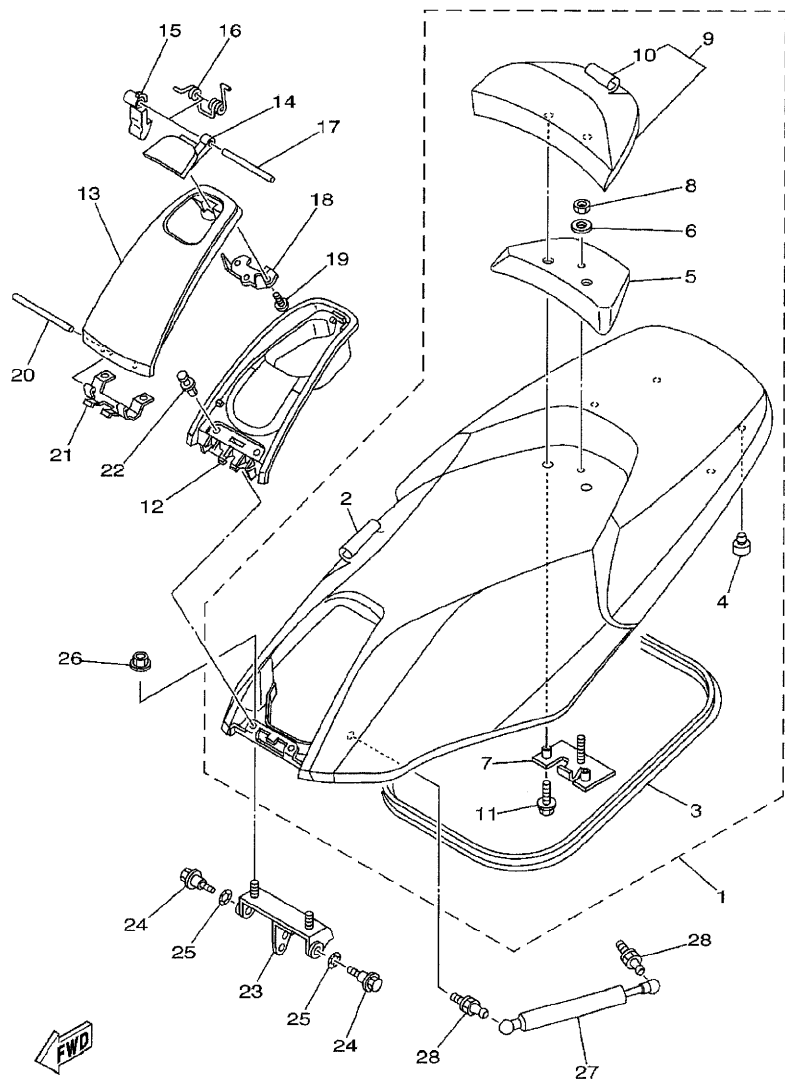

5GJ5300-A260

REF. NO.	PART NO.	DESCRIPTION	5GJ5				REMARKS
1	5GJ-24730-00	DOUBLE SEAT ASSY	1				
2	5GJ-2470F-00	.SEAT COVER COMP.	1				
3	5GJ-2475M-00	.SEAL	1				
4	5GJ-24741-00	.PAD, SEAT	4				
5	5GJ-24792-00	.PLATE	1				
6	90201-06008	.WASHER, PLATE	1				
7	5GJ-24748-00	.BRACKET, SEAT	1				
8	95607-06200	.NUT, SELF U-FLANGE	1				
9	5GJ-24790-00	.SEAT BACK ASSY	1				
10	5GJ-2477A-00	.SEAT COVER ASSY	1				
11	95807-06020	.BOLT, FLANGE	2				
12	5GJ-2473F-00	COVER, SEAT COMP.	1				
13	5GJ-2473T-00	LID 1	1				
14	5GJ-2477F-00	LEVER, SEAT	1				
15	5GJ-24754-00	HOOK, SEAT	1				
16	4HC-24758-00	SPRING	1				
17	93603-50195	PIN, DOWEL	1				
18	5GJ-24217-00	COVER	1				
19	97707-04108	SCREW, TAPPING	2				
20	5GJ-24774-00	PIN	1				
21	5GJ-24762-00	REINFORCEMENT	1				
22	90269-07076	RIVET	3				
23	5GJ-2197J-00	HINGE 1	1				
24	90109-063F5	BOLT	2				
25	90206-10036	WASHER, WAVE	2				
26	95707-08500	NUT, FLANGE	2				
27	5GJ-2478G-00	STOPPER	1				

FIG. 26 SEAT

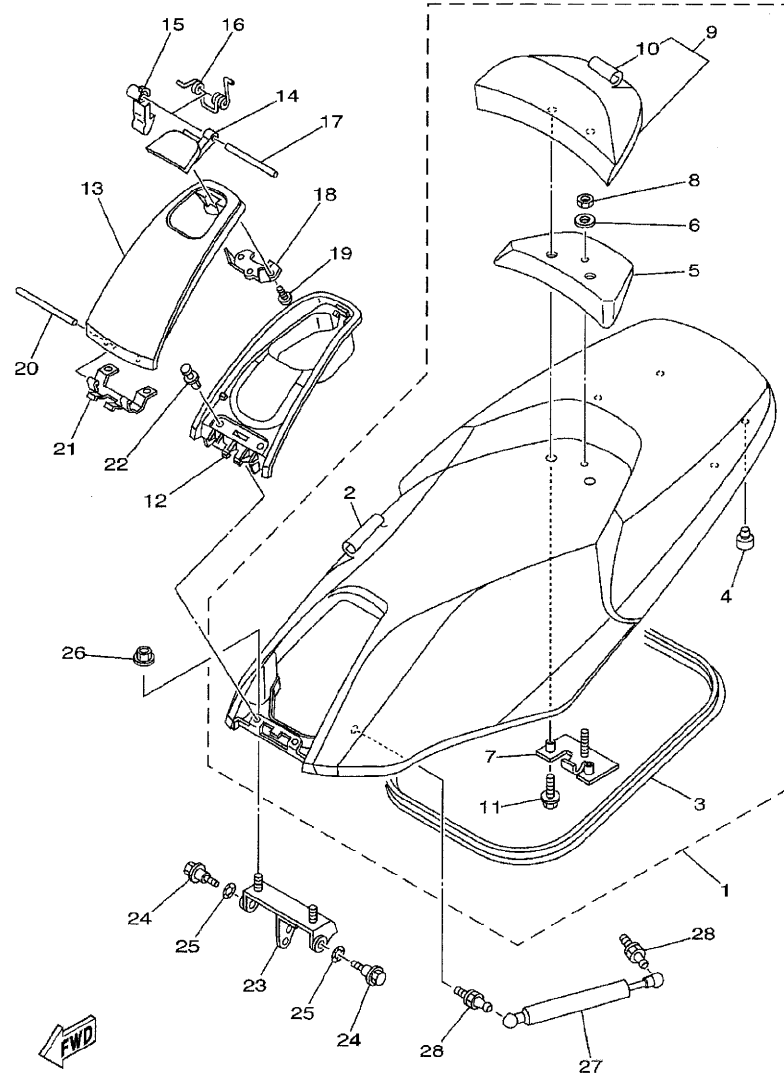

REF. NO.	PART NO.	DESCRIPTION	5GJ5	REMARKS
28	5GM-2474E-00	ARM	2	

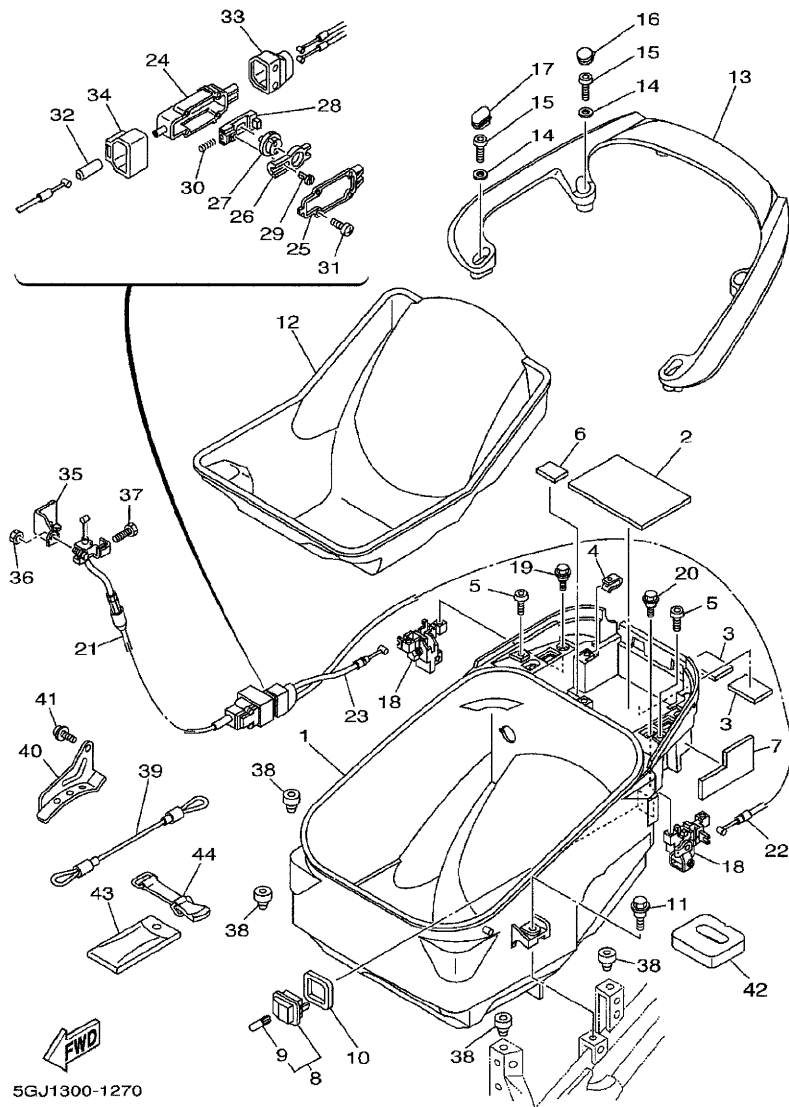
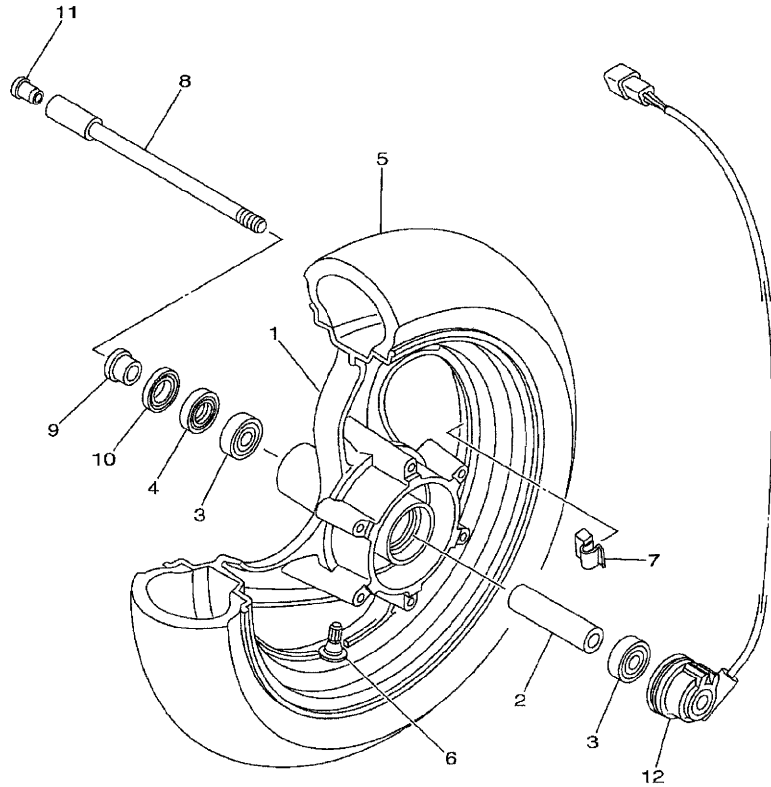

FIG. 27 SEAT 2

REF. NO.	PART NO.	DESCRIPTION	5GJ5	REMARKS
1	5GJ-2473R-00	BOX 1	1	
2	5GJ-27414-00	DAMPER, FOOTREST	1	
3	5GJ-27445-00	PLATE 1	2	
4	90183-05076	NUT, SPRING	3	
5	90111-05002	BOLT	2	
6	5GJ-24723-00	DAMPER, SEAT	1	
7	5GJ-24737-00	DAMPER, SEAT	1	
8	4HC-84770-00	LIGHT, ACCESSORY	1	
9	4HC-84347-00	BULB (12V-2W)	1	
10	5GJ-2839M-00	SEAL, BOX 2	1	
11	90109-063F1	BOLT	2	
12	5GJ-24747-00	DAMPER, SEAT	1	
13	5GJ-24773-00-P0	HANDLE, SEAT	1	SM1
14	90201-08088	WASHER, PLATE	4	
15	92017-08030	BOLT, BUTTON HEAD	4	
16	5GJ-2476V-00	PROTECTOR,2	2	
17	5GJ-2476U-00	PROTECTOR,1	2	
18	5GM-24780-01	SEAT LOCK ASSY	2	
19	90109-06036	BOLT	2	
20	95807-06016	BOLT, FLANGE	2	
21	5GJ-2478E-00	CABLE, SEAT LOCK	1	
22	5GJ-2473W-10	WIRE	1	
23	5GJ-2473W-00	WIRE	1	
24	2T5-26261-02	CONNECTOR, CABLE	1	
25	2T5-26262-00	CAP, CABLE CONNECTOR	1	
26	2T5-26274-00	GUIDE, ROTOR	1	
27	2T5-26273-00	ROTOR	1	

FIG. 28 FRONT WHEEL



REF. NO.	PART NO.	DESCRIPTION	5GJ5			REMARKS
1	5GJ-25168-00-33	CAST WHEEL, FRONT	1			YB
2	90387-1508E	COLLAR	1			
3	93306-30202	BEARING	2			
4	93102-22014	OIL SEAL	1			
5	*	TYRE(120/70 -14M/C55S)	1			
6	93900-00030	VALVE, RIM	1			
7	5MT-25398-00	BALANCER, WHEEL (10G)	1			UN
	5MT-25398-10	BALANCER, WHEEL (20G)	1			UN
	5MT-25398-20	BALANCER, WHEEL (30G)	1			UN
* 8	5GJ-25181-10	AXLE, WHEEL	1			
* 9	5GJ-25183-10	COLLAR, WHEEL	1			
10	5GJ-25118-00	COVER, HUB DUST	1			
11	90338-16004	PLUG	1			
12	5GJ-83755-00	SENSOR, SPEED	1			



5GJ1300-1280

FIG. 30 REAR WHEEL

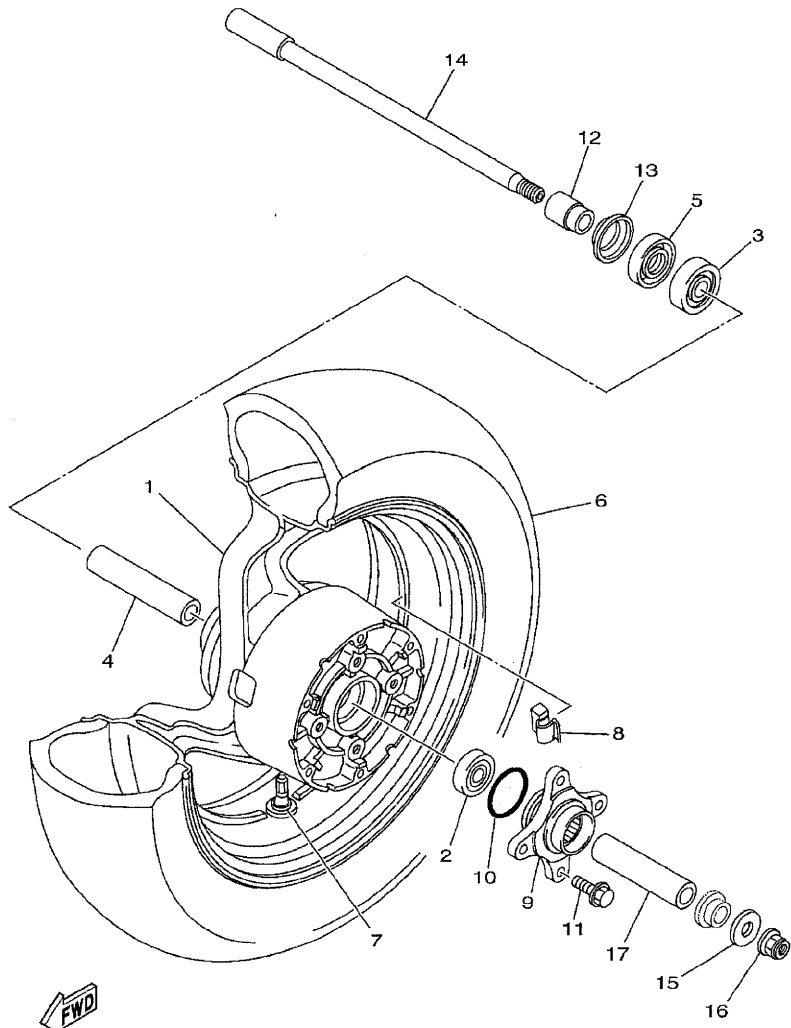

5GJ1300-1300

REF. NO.	PART NO.	DESCRIPTION	5GJ5	REMARKS
1	5GJ-25338-00-33	CAST WHEEL, REAR	1	YB
2	93306-20331	BEARING	1	
3	93306-30317	BEARING	1	
4	90387-173M5	COLLAR	1	
5	93102-25044	OIL SEAL	1	
6	*	TYRE(150/70 -14M/C66S)	1	
7	93900-00030	VALVE, RIM	1	
8	5MT-25398-00	BALANCER, WHEEL (10G)	1	UN
	5MT-25398-10	BALANCER, WHEEL (20G)	1	UN
	5MT-25398-20	BALANCER, WHEEL (30G)	1	UN
9	5GJ-25366-00	CLUTCH, HUB	1	
10	93210-44704	O-RING	1	
11	90105-10200	BOLT, FLANGE	4	
12	5GJ-25377-00	COLLAR, WHEEL	1	
13	5GJ-25367-00	COVER, HUB DUST	1	
14	5GJ-25381-00	AXLE, WHEEL	1	
15	90201-141A3	WASHER, PLATE	1	
16	95607-14200	NUT, SELF-LOCKING	1	
17	90560-17306	SPACER	1	

FIG. 31 REAR BRAKE CALIPER

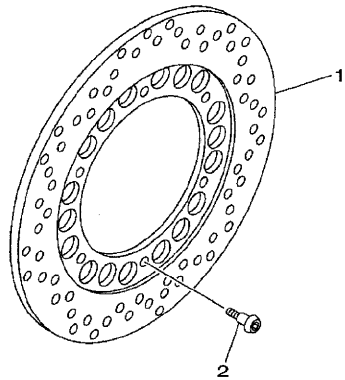
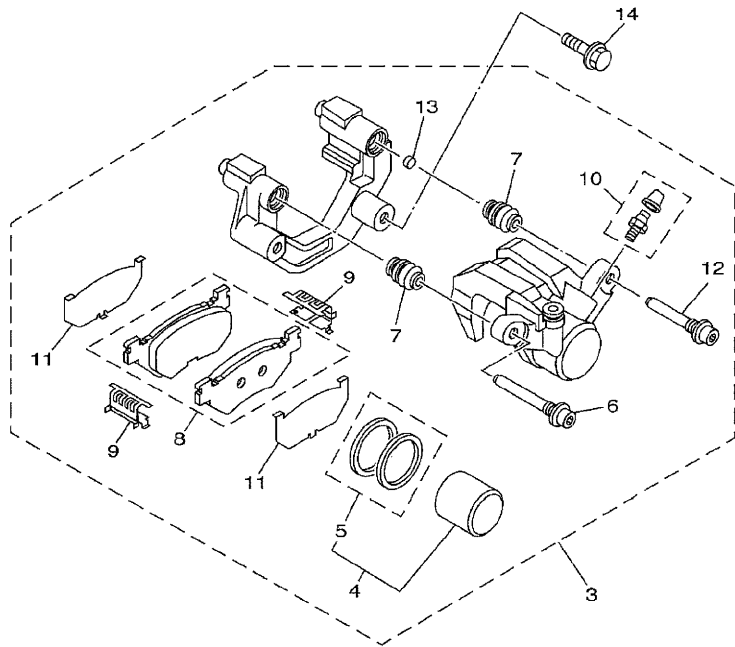

REF. NO.	PART NO.	DESCRIPTION	5GJ45				REMARKS
1	3GM-2582W-A0	DISC, REAR BRAKE 2	1				
2	90109-064G6	BOLT	6				
3	5GJ-2580V-01	CALIPER ASSY, REAR 1	1				
4	5GJ-W0057-01	.PISTON ASSY, CALIPER	1				
5	5GJ-W0047-00	.CALIPER SEAL KIT	1				
6	5GM-25914-00	.PIN, SLIDE	1				
7	4TT-25937-00	.BOOT 2	2				
8	5GJ-W0046-00	.BRAKE PAD KIT 2	1				
9	4TT-25919-00	.SUPPORT, PAD	2				
10	5GM-W0048-00	.BLEED SCREW KIT	1				
11	5GJ-25827-00	.SHIM, CALIPER	2				
12	5GJ-25926-00	.BOLT	1				
13	5GJ-25915-00	.PLUG	1				
14	90105-10638	BOLT, FLANGE	2				



5GJ4010-1310

FIG. 32 STEERING HANDLE. CABLE

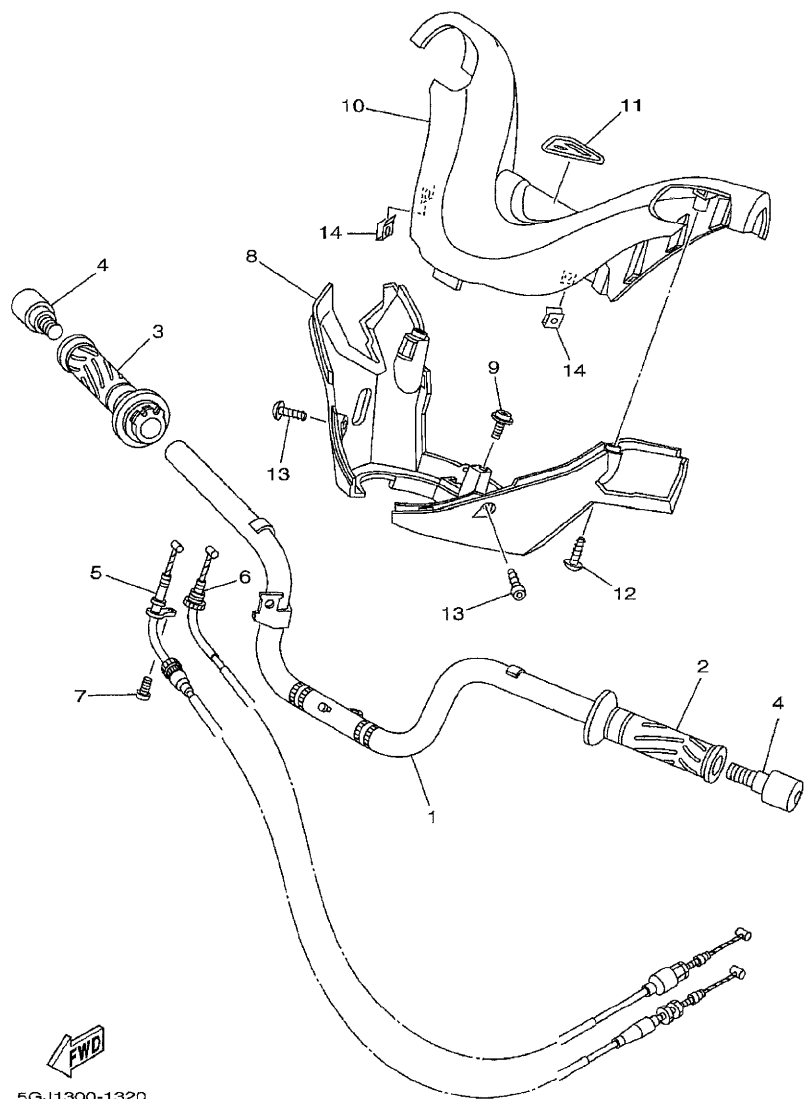

5GJ1300-1320

REF. NO.	PART NO.	DESCRIPTION	5GJ5				REMARKS
1	5GJ-26110-02	HANDLE COMP.	1				
2	4YR-26241-01	GRIP	1				
3	5GJ-26240-00	GRIP ASSY	1				
4	5GJ-26246-00	END, GRIP	2				
5	5GJ-26311-03	CABLE, THROTTLE 1	1				
6	5GJ-26312-03	CABLE, THROTTLE 2	1				
7	98507-05010	SCREW, PAN HEAD	1				
8	5GJ-26144-01	COVER, HANDLEBAR LOWER 1	1				
9	90159-05028	SCREW, WITH WASHER	1				
10	5GJ-26143-00	COVER, HANDLEBAR UPPER 1	1				
11	5GJ-26219-00	EMBLEM	1				
12	90167-05080	SCREW, TAPPING	2				
13	90167-05079	SCREW, TAPPING	2				
14	90183-05042	NUT, SPRING	2				

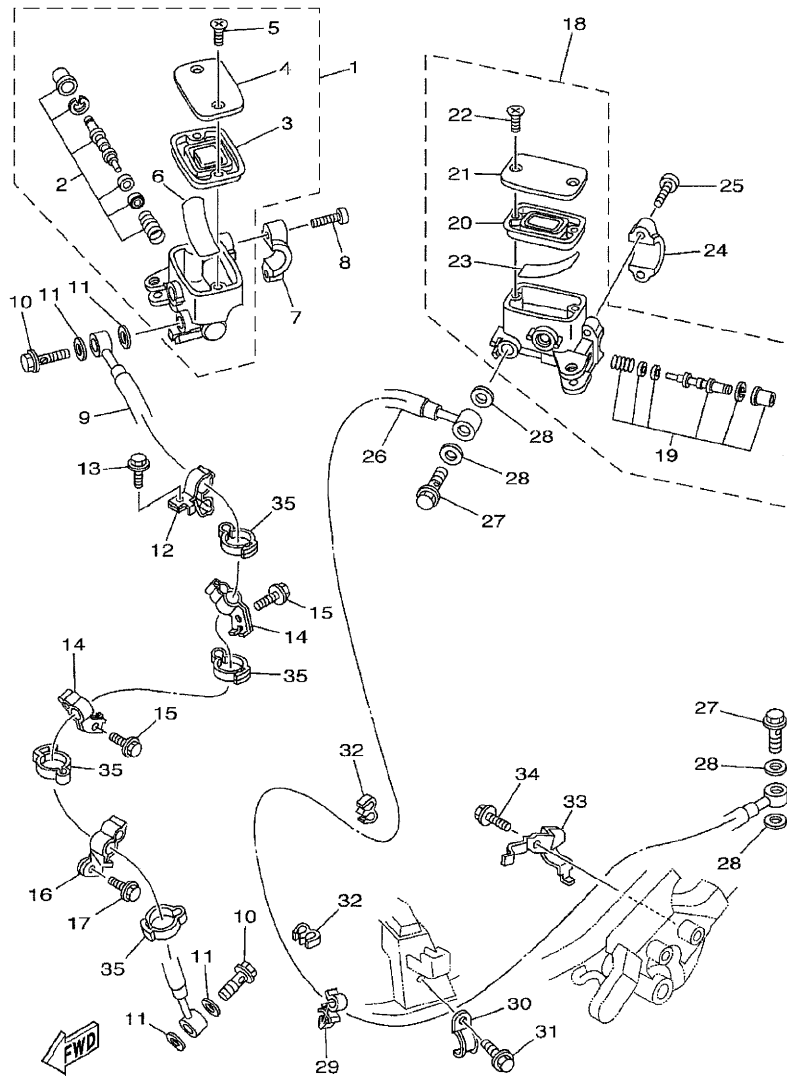
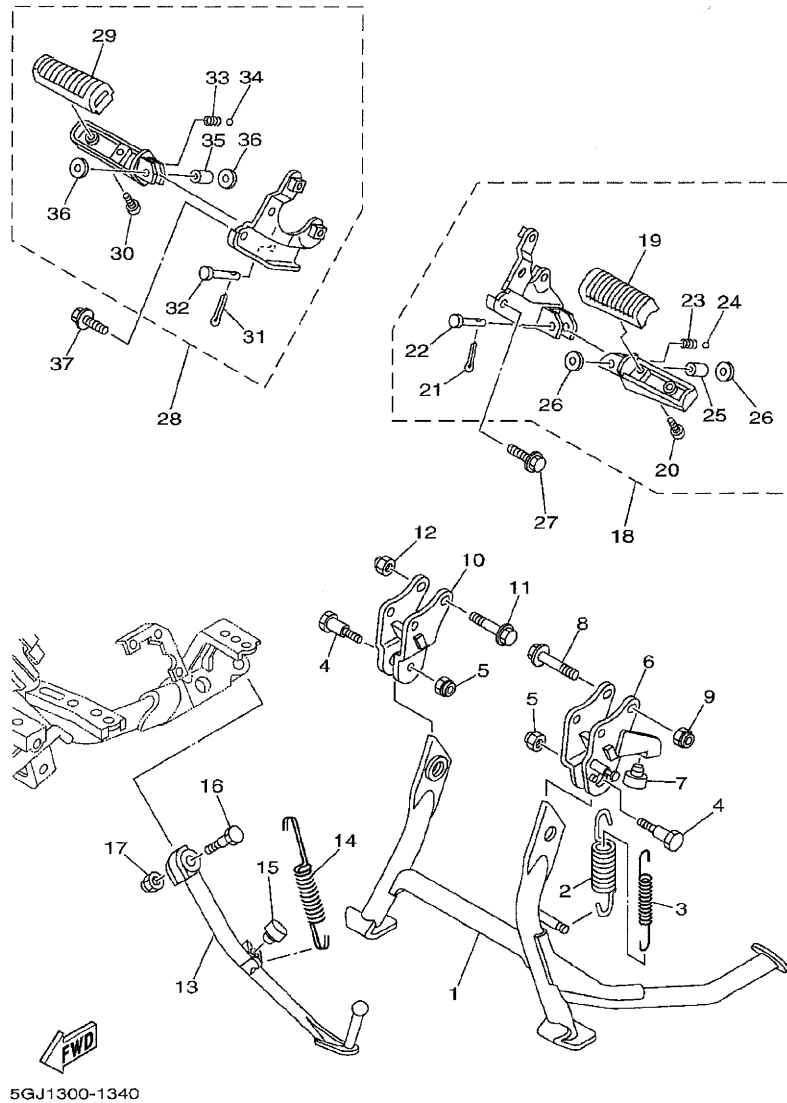

FIG. 33 FRONT MASTER CYLINDER

REF. NO.	PART NO.	DESCRIPTION	5GJ5				REMARKS
1	5GJ-25870-00	MASTER CYLINDER SUB ASSY	1				
2	5GJ-W0041-00	.CYLINDER KIT, MASTER	1				
3	3YX-25854-00	.DIAPHRAGM, RESERVOIR	1				
4	4TX-25852-00	.CAP, RESERVOIR	1				
5	98706-04012	.SCREW, FLAT HEAD	2				
6	3YX-25896-00	.PLATE, RESERVOIR	1				
7	3RW-25867-00	BRACKET, MASTER CYLINDER	1				
8	91317-06025	BOLT	2				
9	5GJ-25872-00	HOSE, BRAKE 1	1				
10	90401-10172	BOLT, UNION	2				
11	90201-10118	WASHER, PLATE	4				
12	5GJ-25875-10	HOLDER, BRAKE HOSE 1	1				
13	95807-06016	BOLT, FLANGE	1				
14	5GJ-25875-00	HOLDER, BRAKE HOSE 1	2				
15	95807-06010	BOLT, FLANGE	2				
16	5GJ-25876-00	HOLDER, BRAKE HOSE 2	1				
17	95807-06020	BOLT, FLANGE	1				
18	5GJ-25870-10	MASTER CYLINDER SUB ASSY	1				
19	5GJ-W0041-10	.CYLINDER KIT, MASTER	1				
20	3YX-25854-00	.DIAPHRAGM, RESERVOIR	1				
21	4TX-25852-00	.CAP, RESERVOIR	1				
22	98706-04012	.SCREW, FLAT HEAD	2				
23	3YX-25896-00	.PLATE, RESERVOIR	1				
24	3RW-25867-00	BRACKET, MASTER CYLINDER	1				
25	91317-06025	BOLT	2				
26	5GJ-2584A-00	BRAKE HOSE ASSY	1				
27	90401-10172	BOLT, UNION	2				

FIG. 34 STAND. FOOTREST



REF. NO.	PART NO.	DESCRIPTION	5GJ15				REMARKS
1	5GJ-27111-01	STAND, MAIN	1				
2	90506-40508	SPRING, TENSION	1				
3	90506-23509	SPRING, TENSION	1				
4	90109-101E6	BOLT	2				
5	90185-10091	NUT, SELF-LOCKING	2				
6	5GJ-27151-00	BRACKET, MAIN STAND	1				
7	4X4-27114-00	STOPPER, MAIN STAND	1				
8	90105-10388	BOLT, FLANGE	2				
9	90185-10091	NUT, SELF-LOCKING	2				
10	5GJ-27152-00	BRACKET, MAIN STAND 2	1				
11	90105-10388	BOLT, FLANGE	2				
12	90185-10091	NUT, SELF-LOCKING	2				
13	5GJ-27311-00	STAND, SIDE	1				
14	90506-20002	SPRING, TENSION	1				
15	4X4-27114-00	STOPPER, MAIN STAND	1				
16	90109-10474	BOLT	1				
17	90185-10037	NUT, SELF-LOCKING	1				
18	5GJ-27430-00	REAR FOOTREST ASSY 1	1				
19	4BP-27413-00	.COVER, FOOTREST	1				
20	90157-05079	.SCREW, PAN HEAD	2				
21	91401-20012	.PIN, COTTER	1				
22	91701-06035	.PIN, CLEVIS	1				
23	90501-12743	.SPRING, COMPRESSION	1				
24	93501-04011	.BALL	1				
25	90387-064H8	.COLLAR	1				
26	2NT-27437-00	.WASHER, SPECIAL	2				
27	95807-08016	BOLT, FLANGE	2				

FIG. 34 STAND. FOOTREST

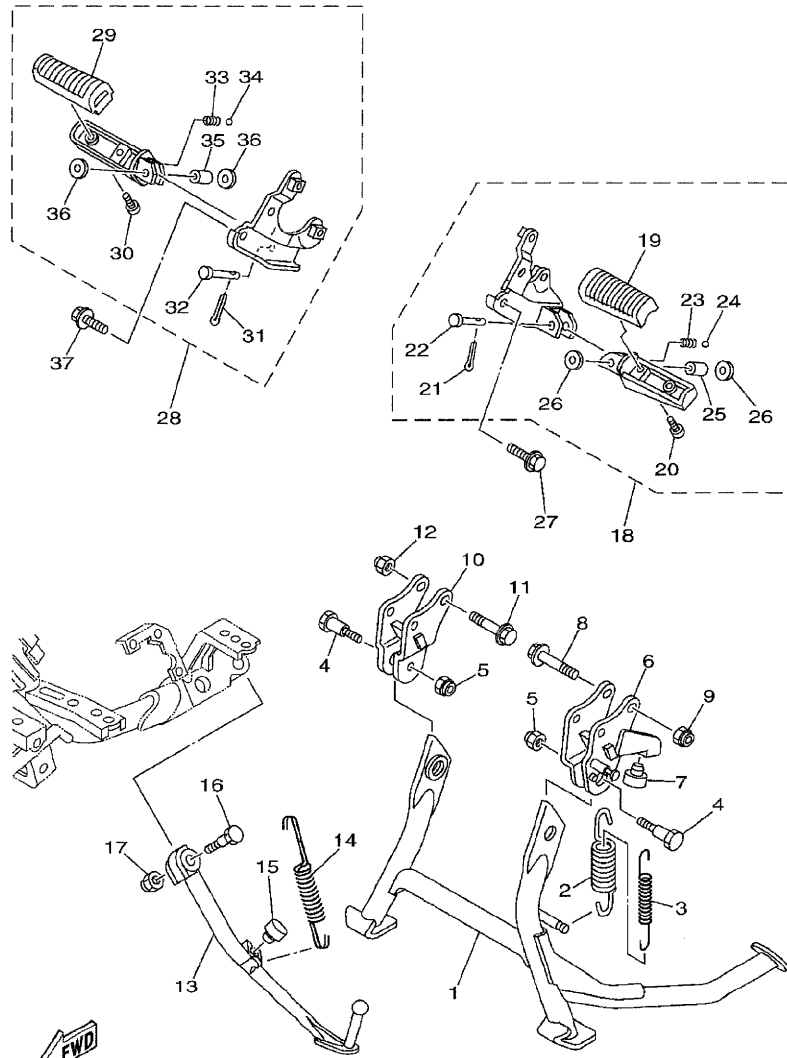

5GJ1300-1340

REF. NO.	PART NO.	DESCRIPTION	5GJ5				REMARKS
28	5GJ-27440-00	REAR FOOTREST ASSY 2	1				
29	4BP-27413-00	.COVER, FOOTREST	1				
30	90157-05079	.SCREW, PAN HEAD	2				
31	91401-20012	.PIN, COTTER	1				
32	91701-06035	.PIN, CLEVIS	1				
33	90501-12743	.SPRING, COMPRESSION	1				
34	93501-04011	.BALL	1				
35	90387-064H8	.COLLAR	1				
36	2NT-27437-00	.WASHER, SPECIAL	2				
37	95807-08016	BOLT, FLANGE	2				

FIG. 35 STAND.FOOTREST 2

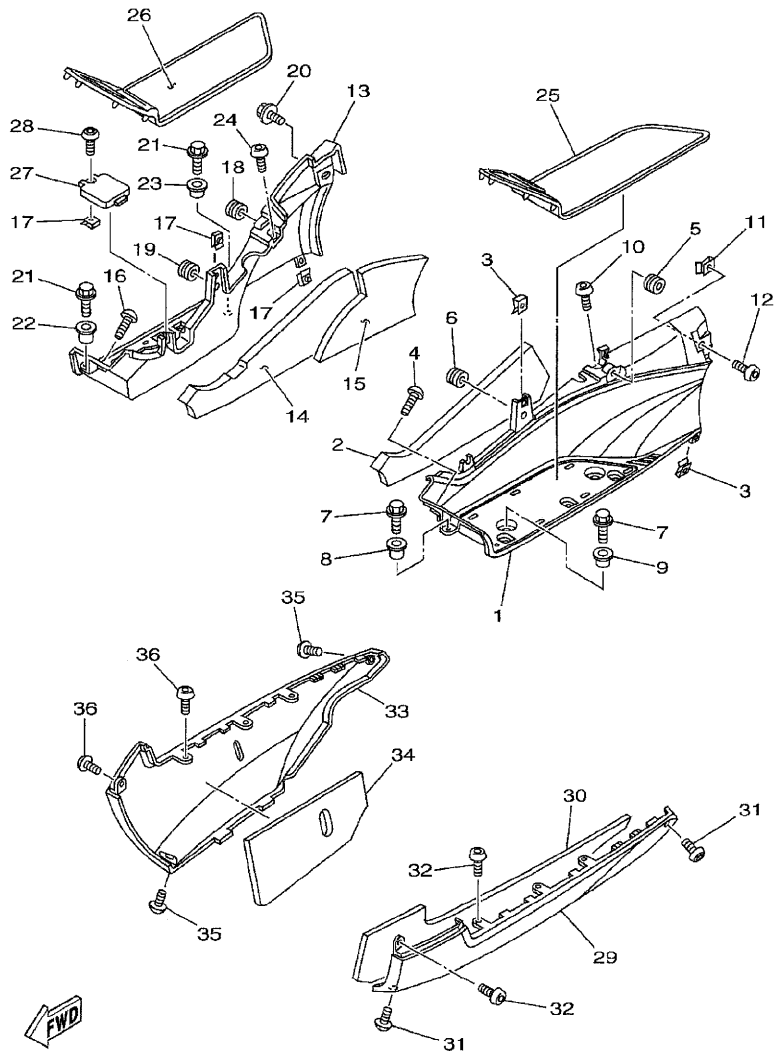

5GJ1300-1350

REF. NO.	PART NO.	DESCRIPTION	5GJ5			REMARKS
1	5GJ-27481-00	BOARD, FOOTREST	1			
2	5GJ-2174X-00	DAMPER	1			
3	90183-05042	NUT, SPRING	6			
4	90167-05079	SCREW, TAPPING	1			
5	90480-01558	GROMMET	1			
6	90480-13567	GROMMET	1			
7	95807-06016	BOLT, FLANGE	3			
8	90387-061F9	COLLAR	1			
9	90387-066R8	COLLAR	2			
10	90111-06009	BOLT	1			
11	90183-05042	NUT, SPRING	1			
12	90167-05079	SCREW, TAPPING	1			
13	5GJ-27488-00	BOARD, FOOTREST 2	1			
14	5GJ-2174Y-00	DAMPER	1			
15	5GJ-21746-00	DAMPER	1			
16	90167-05079	SCREW, TAPPING	1			
17	90183-05042	NUT, SPRING	7			
18	90480-01558	GROMMET	2			
19	90480-13567	GROMMET	1			
20	90119-06060	BOLT, WITH WASHER	1			
21	95807-06016	BOLT, FLANGE	3			
22	90387-061F9	COLLAR	1			
23	90387-066R8	COLLAR	2			
24	90111-06009	BOLT	1			
25	5GJ-27483-00	MAT 1	1			
26	5GJ-27484-00	MAT 2	1			
27	5GJ-27463-00	COVER 2	1			

FIG. 35 STAND.FOOTREST 2

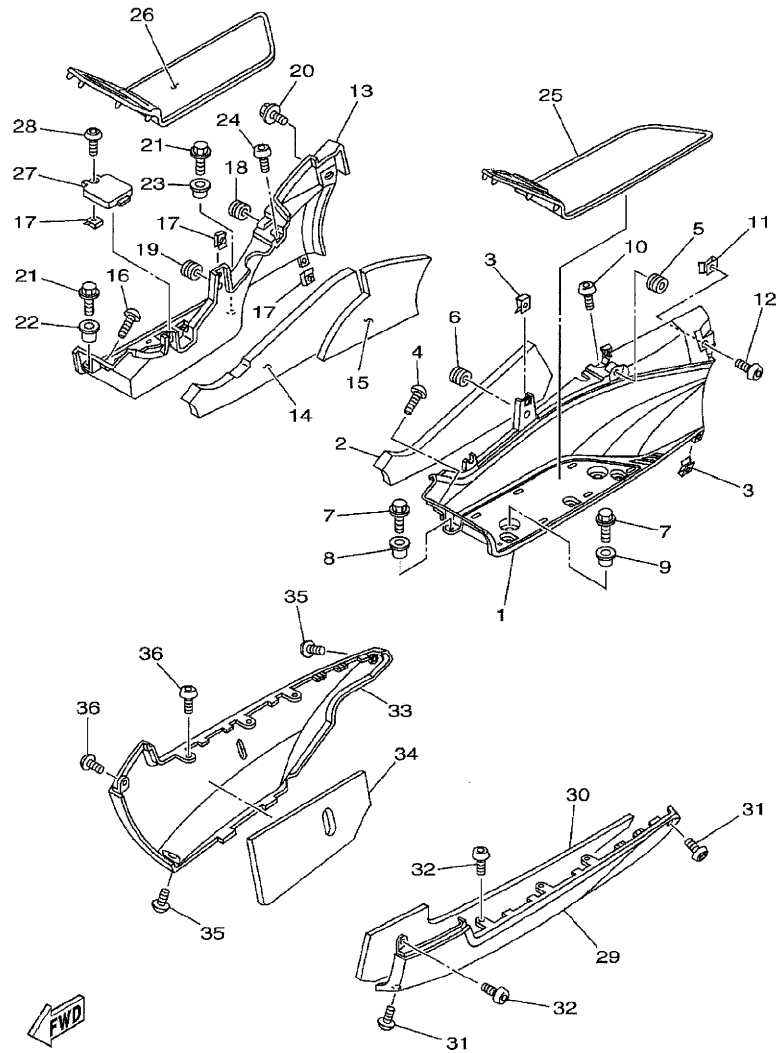

5GJ1300-1350

REF. NO.	PART NO.	DESCRIPTION	5GJ5	REMARKS
28	97707-50012	SCREW, TAPPING	1	
29	5GJ-2171L-00-P0	MOLE, SIDE COVER 1	1	SM1
30	5GJ-2177M-00	DAMPER, LOCATING 3	1	
31	90167-05076	SCREW, TAPPING	2	
32	97707-50012	SCREW, TAPPING	4	
33	5GJ-2171M-00-P0	MOLE, SIDE COVER 2	1	SM1
34	5GJ-2177N-00	DAMPER, LOCATING 4	1	
35	90167-05076	SCREW, TAPPING	2	
36	97707-50012	SCREW, TAPPING	4	

FIG. 36 LEG SHIELD

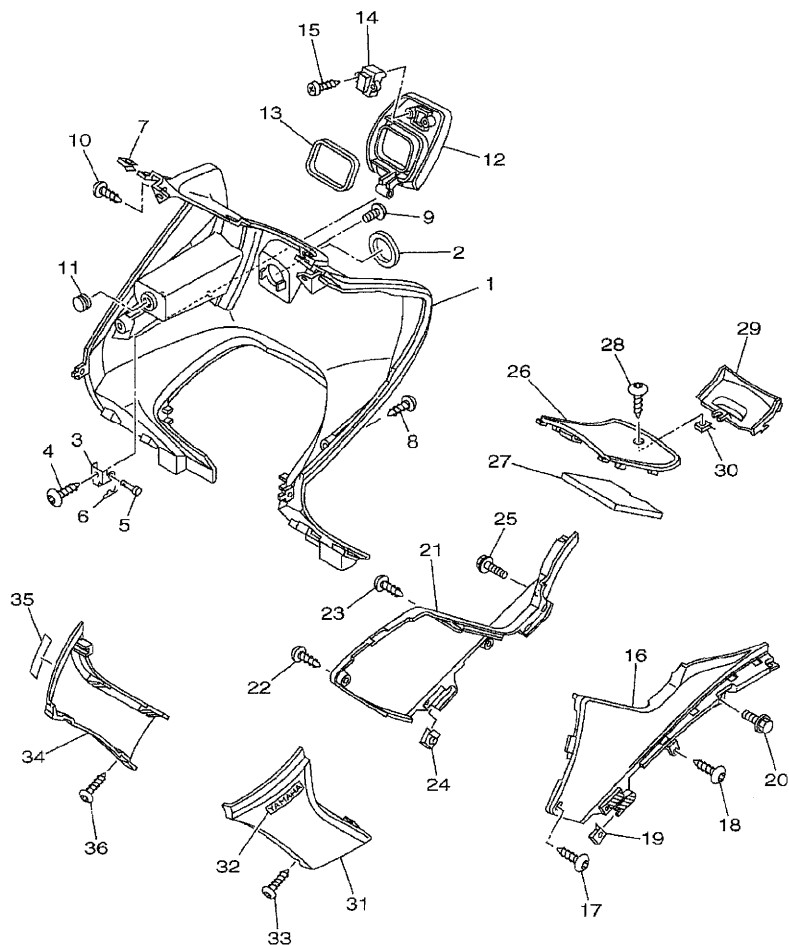

5GJ1300-1360

REF. NO.	PART NO.	DESCRIPTION	5GJ5			REMARKS
1	5GJ-28311-00	LEG SHIELD 1	1			
2	5GJ-28307-00	SEAL	1			
3	5GJ-21796-00	HINGE	1			
4	97707-50012	SCREW, TAPPING	1			
5	90240-04002	PIN, CLEVIS	1			
6	90468-10004	CLIP	1			
7	90183-05042	NUT, SPRING	18			
8	90167-05077	SCREW, TAPPING	4			
9	90111-05002	BOLT	1			
10	97707-50012	SCREW, TAPPING	2			
11	90338-20113	PLUG	1			
12	5GJ-28313-00	LID	1			
13	5GJ-28371-00	DAMPER	1			
14	5GJ-21780-00	LOCK ASSY	1			
15	97707-40510	SCREW, TAPPING	2			
16	5GJ-28219-00	COVER 1	1			
17	90167-05077	SCREW, TAPPING	1			
18	97707-50012	SCREW, TAPPING	3			
19	90183-05042	NUT, SPRING	1			
20	90119-06060	BOLT, WITH WASHER	1			
21	5GJ-28229-00	COVER 2	1			
22	90167-05077	SCREW, TAPPING	1			
23	97707-50012	SCREW, TAPPING	3			
24	90183-05042	NUT, SPRING	1			
25	90119-06060	BOLT, WITH WASHER	1			
26	5GJ-2171E-00	COVER, SIDE 5	1			
27	5GJ-28267-00	DAMPER 5	1			

FIG. 36 LEG SHIELD

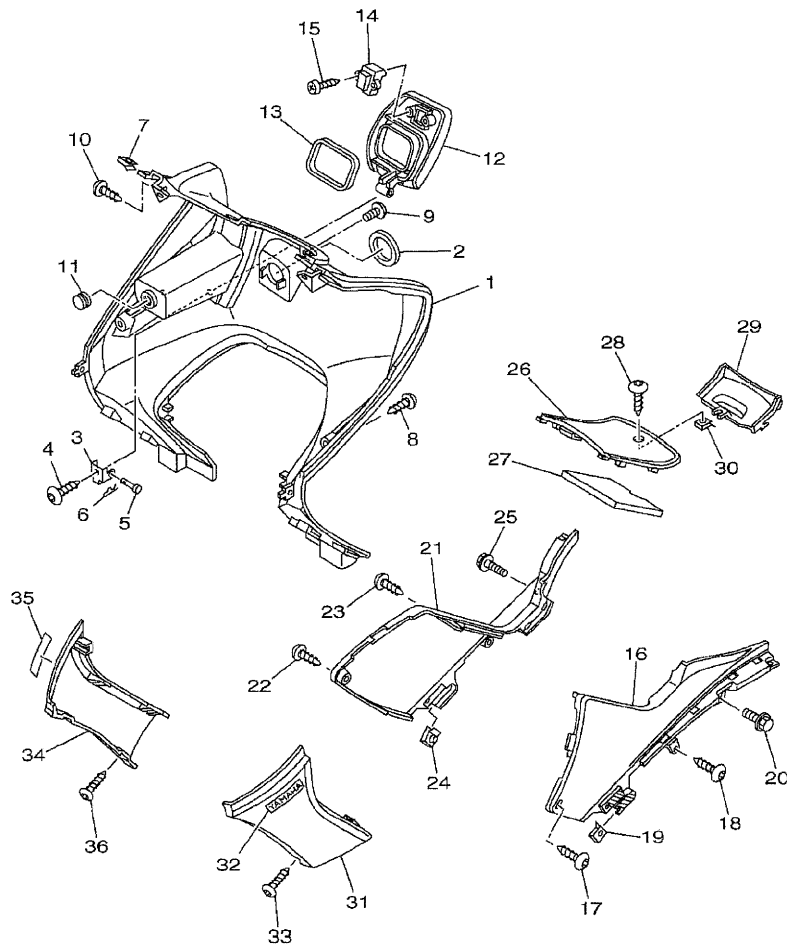

5GJ1300-1360

REF. NO.	PART NO.	DESCRIPTION	5GJ5			REMARKS
28	90167-05079	SCREW, TAPPING	1			
29	5GJ-2846K-00	COVER, HINGE 1	1			
30	90183-05042	NUT, SPRING	1			
31	5GJ-2835U-00-33	PANEL 1	1			YB
32	99246-00080	EMBLEM, YAMAHA	1			
33	97707-50012	SCREW, TAPPING	4			
34	5GJ-2835V-00-33	PANEL 2	1			YB
35	99246-00080	EMBLEM, YAMAHA	1			
36	97707-50012	SCREW, TAPPING	4			

FIG. 37 WINDSHIELD

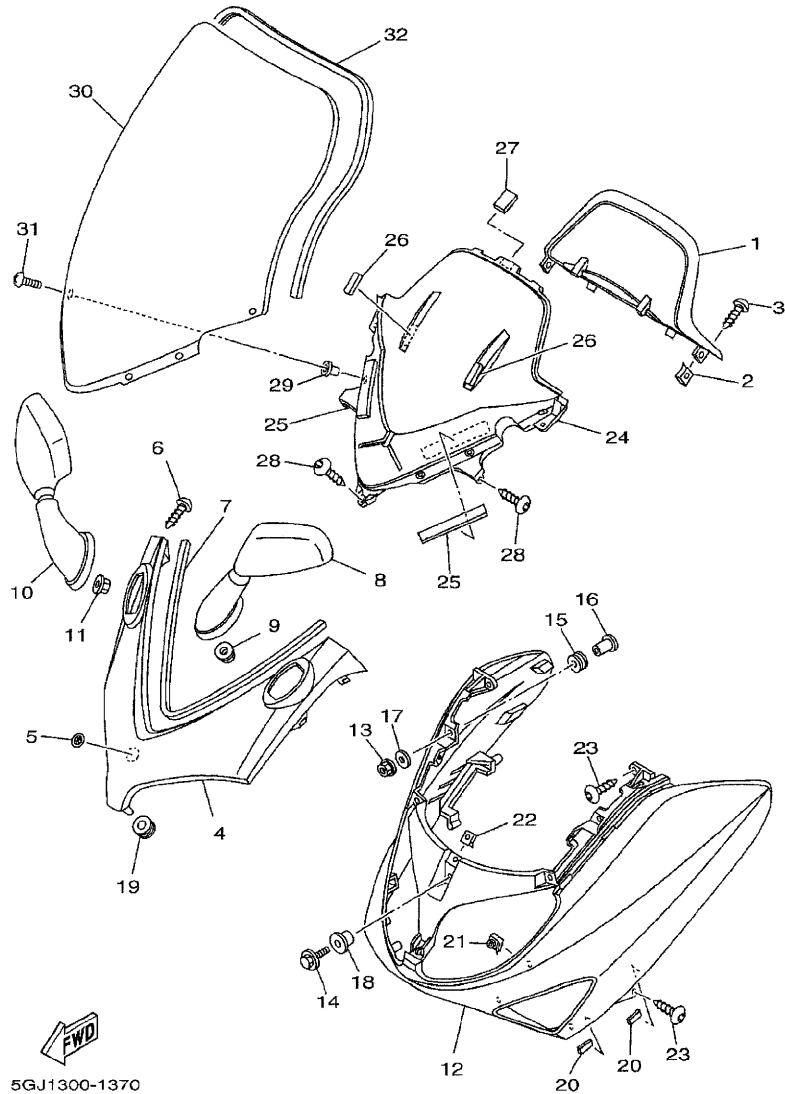

REF. NO.	PART NO.	DESCRIPTION	5GJ5				REMARKS
1	5GJ-2836K-01	PANEL, INNER 1	1				
2	90183-05042	NUT, SPRING	2				
3	90167-05079	SCREW, TAPPING	2				
4	5GJ-28345-00-P0	MOLE 1	1				BM2
5	5GM-2836B-01	TUNING FORK MARK	1				
6	90167-05079	SCREW, TAPPING	2				
7	5GJ-28347-00	MOLE 3	1				
8	5GJ-26280-10	REAR VIEW MIRROR ASSY (LEFT)	1				
9	95707-06500	NUT, FLANGE	2				
10	5GJ-26290-10	REAR VIEW MIRROR ASSY (RIGHT)	1				
11	95707-06500	NUT, FLANGE	2				
12	5GJ-28350-00-AL	COWLING ASSY	1				UR CMY
13	95707-06500	NUT, FLANGE	2				
14	95807-06025	BOLT, FLANGE	3				
15	90480-15058	GROMMET	2				
16	90387-071E0	COLLAR	2				
17	90201-06008	WASHER, PLATE	2				
18	90387-07003	COLLAR	3				
19	90480-01558	GROMMET	1				
20	56J-21747-00	DAMPER	4				
21	3VP-21535-00	NUT 1	2				
22	90183-05042	NUT, SPRING	5				
23	97707-50012	SCREW, TAPPING	4				
24	5GJ-2836L-00	PANEL, INNER 2	1				

FIG. 37 WINDSHIELD

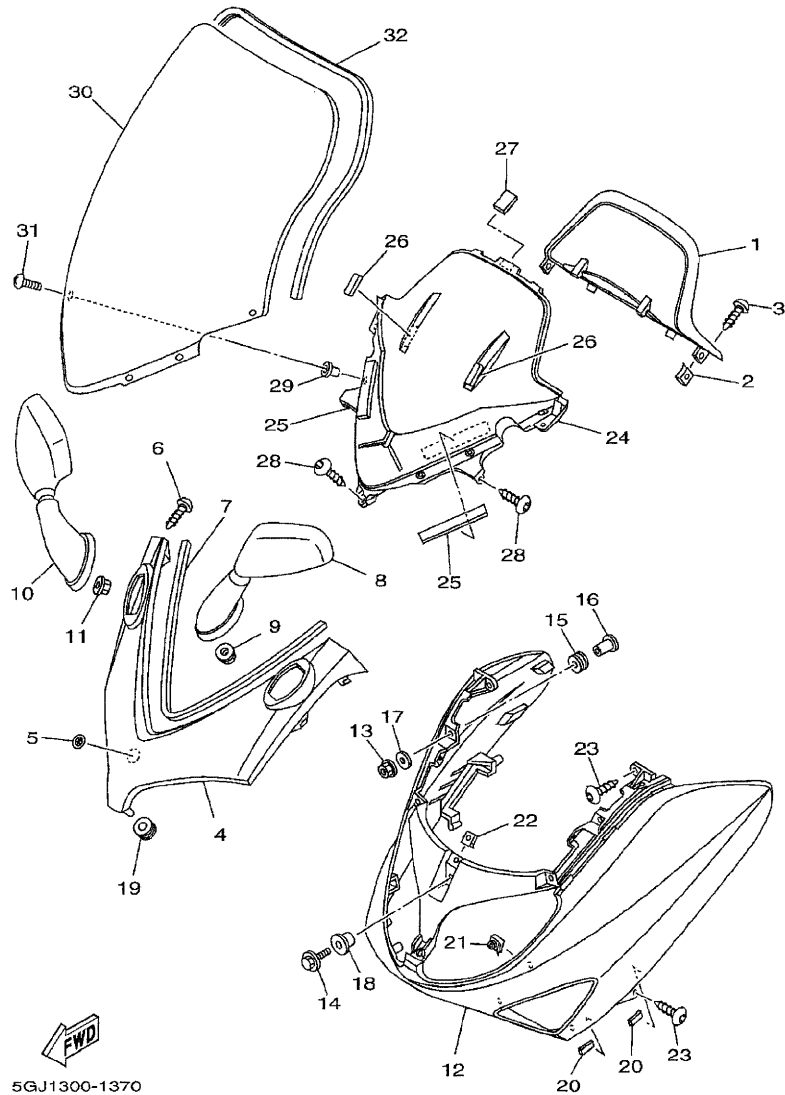

5GJ1300-1370

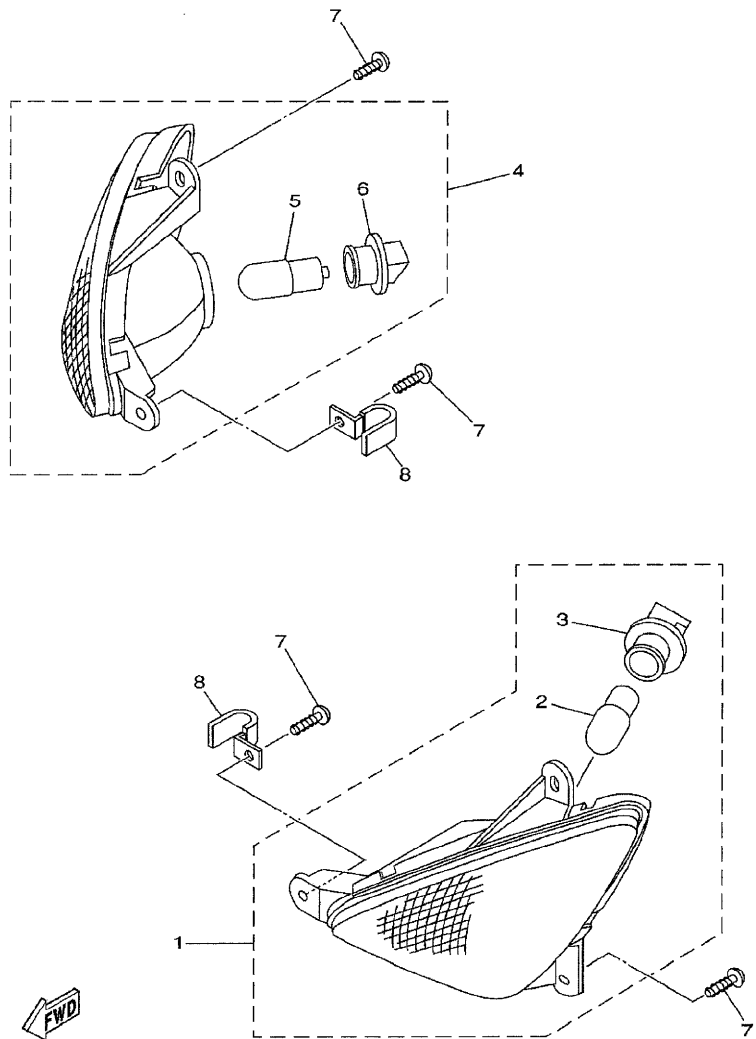

REF. NO.	PART NO.	DESCRIPTION	5GJ5				REMARKS
25	5GJ-28455-10	DAMPER, 4	2				
26	5GJ-28455-20	DAMPER, 4	2				
27	5GJ-24723-00	DAMPER, SEAT	3				
28	97707-50012	SCREW, TAPPING	5				
29	90179-05523	NUT	6				
30	5GJ-Y283P-50	SCREEN	1				
31	90150-05024	SCREW, ROUND HEAD	6				
32	5GJ-28376-00	TRIM	1				

FIG. 39 FLASHER LIGHT

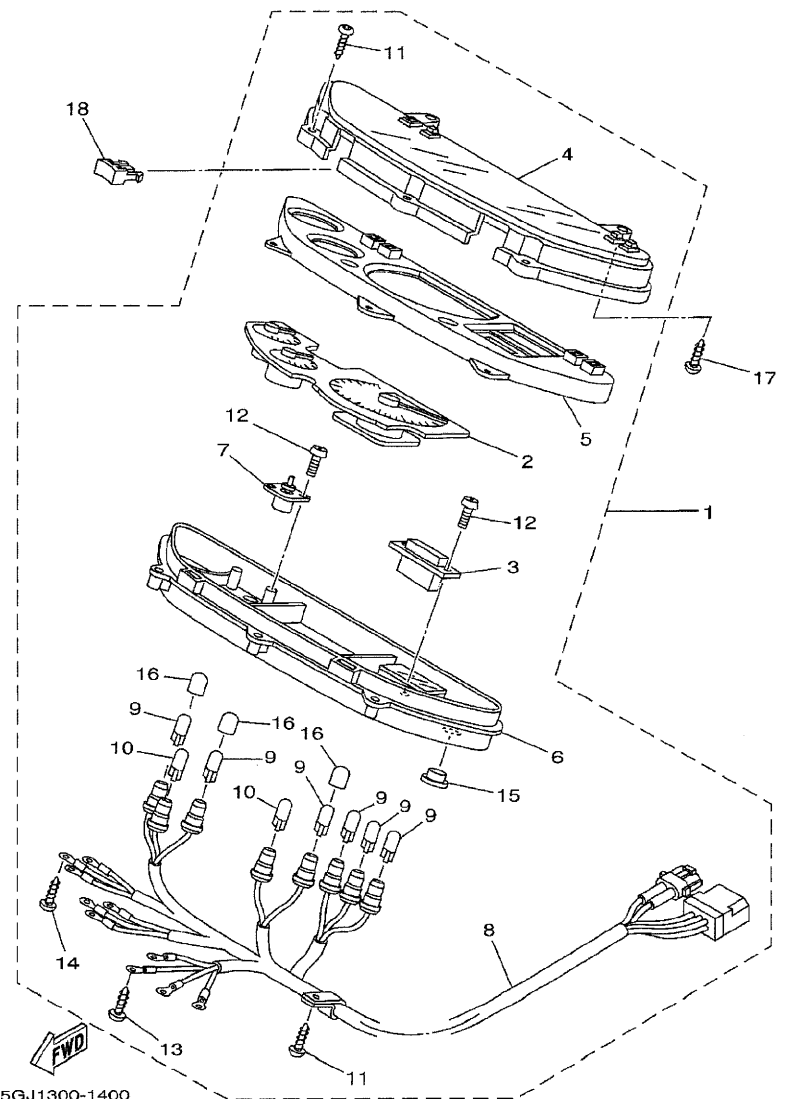

REF. NO.	PART NO.	DESCRIPTION	5GJ15	REMARKS
1	5GJ-83310-00	FRONT FLASHER LIGHT ASSY 1	1	
2	5GJ-83331-00	.BULB, FLASHER	1	
3	5GJ-8331E-00	.CORD ASSY	1	
4	5GJ-83320-00	FRONT FLASHER LIGHT ASSY 2	1	
5	5GJ-83331-00	.BULB, FLASHER	1	
6	5GJ-8331E-00	.CORD ASSY	1	
7	97707-50016	SCREW, TAPPING	6	
8	90462-05005	CLAMP	2	

FIG. 40 METER



5GJ1300-1400

REF. NO.	PART NO.	DESCRIPTION	5GJ5				REMARKS
1	5GJ-83500-00	SPEEDOMETER ASSY	1				UR
2	5GJ-83510-00	.SPEEDOMETER ASSY	1				UR
3	5GM-83740-00	.DIGITAL CLOCK ASSY	1				UR
4	5GJ-83511-00	.LENS, SPEEDOMETER	1				
5	5GJ-83612-00	.COVER, METER PANEL	1				UR
6	5GJ-8353H-00	.CASE, UNDER	1				
7	4HC-83964-00	.SWITCH	1				
8	5GJ-83509-00	.SOCKET CORD ASSY	1				
9	1YT-83517-00	.BULB (12V-1.7W, T10)	6				
10	4R0-83517-00	.BULB (12V-3.4W T10)	2				
11	97707-40016	.SCREW, TAPPING	5				
12	97707-30512	.SCREW, TAPPING	4				
13	5GM-8362Y-00	.SCREW, SPECIAL	5				
14	5GM-83616-00	.SCREW, TAPPING	6				
15	3SX-8352K-00	.PLUG, BLIND	2				
16	2XF-83781-V0	.TUBE	3				
17	97707-50016	SCREW, TAPPING	2				
18	4HC-2837G-00	LOCK 1	2				

FIG. 41 HEADLIGHT

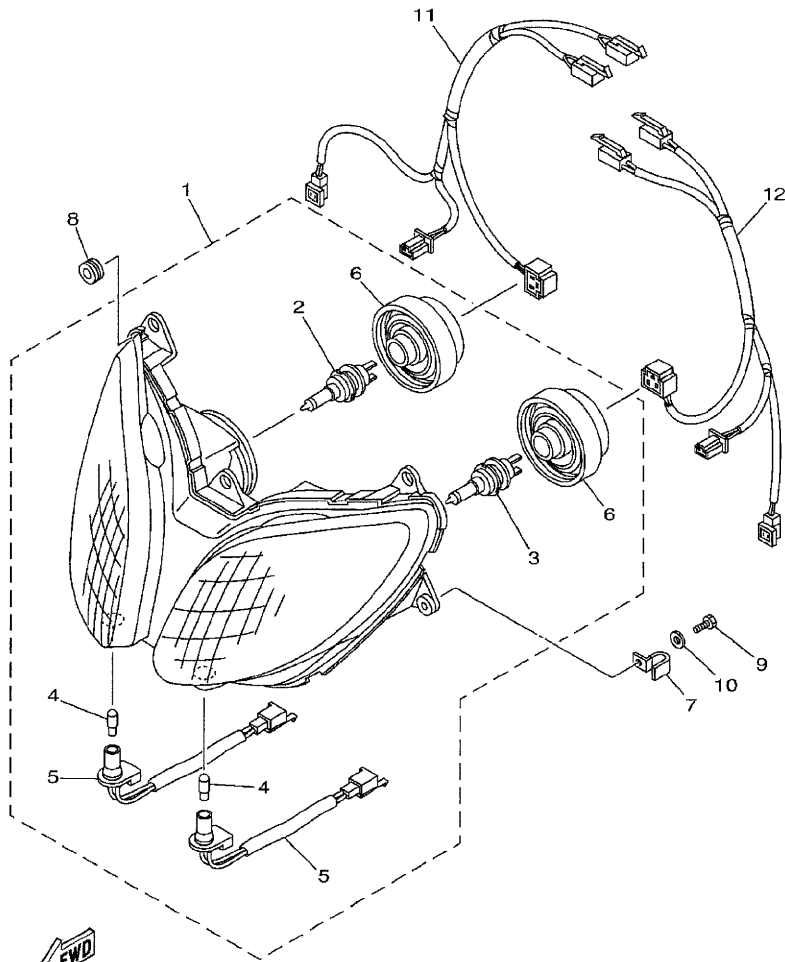

5GJ1300-1410

REF. NO.	PART NO.	DESCRIPTION	5GJ15		REMARKS
1	5GJ-84310-10	HEADLIGHT UNIT ASSY	1		UR FOR ZAF
2	4SV-84314-00	.BULB (12V-55W)	1		
3	8G9-84314-00	.BULB (12V-60/55W)	1		(H4)HALOGEN
4	4SV-84347-00	.BULB (12V-5W)	2		
5	4XV-84312-00	.SOCKET CORD ASSY 1	2		
6	5GJ-84397-00	.COVER, SOCKET	2		
7	90462-05005	CLAMP	2		
8	90480-10289	GROMMET	3		
9	97007-06025	BOLT	2		
10	92907-06600	WASHER, PLATE	2		
11	5GJ-84359-00	CORD, HEADLIGHT	1		
12	5GJ-84359-10	CORD, HEADLIGHT	1		

FIG. 42 TAILLIGHT

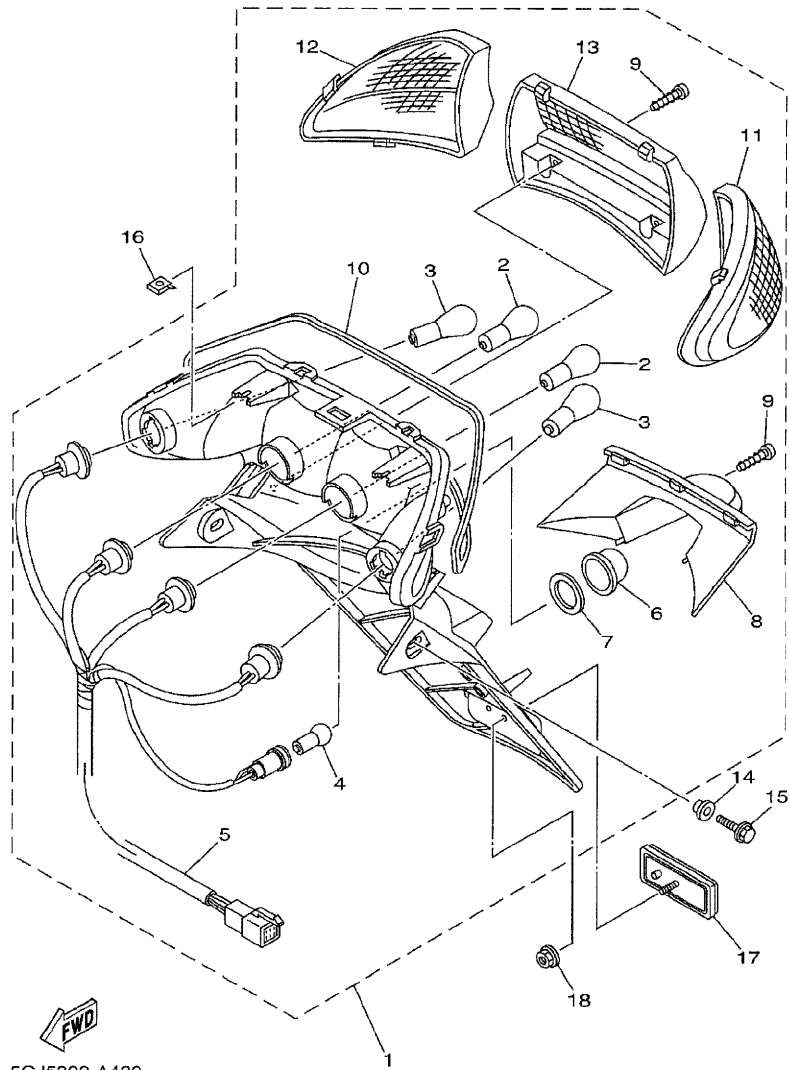

REF. NO.	PART NO.	DESCRIPTION	5GJ5	REMARKS
1	5GJ-84710-00	TAILLIGHT UNIT ASSY	1	
2	36Y-84714-40	.BULB, TAILLIGHT (12V-21/5W)	2	
3	32H-83331-00	.BULB, FLASHER (12V-21W)	2	
4	5GJ-84744-00	.BULB	1	
5	5GJ-84312-00	.HOLDER, SOCKET	1	
6	25G-84743-01	.LENS, LICENCE LIGHT	1	
7	25G-84742-00	.SEAT, BASE	1	
8	5GJ-84516-00	.COVER, TAILLIGHT	1	
9	97702-40614	.SCREW, TAPPING	4	
10	5GJ-84523-00	.GASKET, LENS	1	
11	5GJ-83332-00	.LENS, FLASHER	1	
12	5GJ-83342-00	.LENS, FLASHER 2	1	
13	5GJ-84721-00	.LENS, TAILLIGHT	1	
14	90387-07717	COLLAR	2	
15	90105-06690	BOLT, FLANGE	2	
16	90183-05042	NUT, SPRING	4	
17	3Y6-85130-02	REAR REFLECTOR ASSY	1	
18	95707-05500	NUT, FLANGE	1	

FIG. 43 HANDLE SWITCH. LEVER

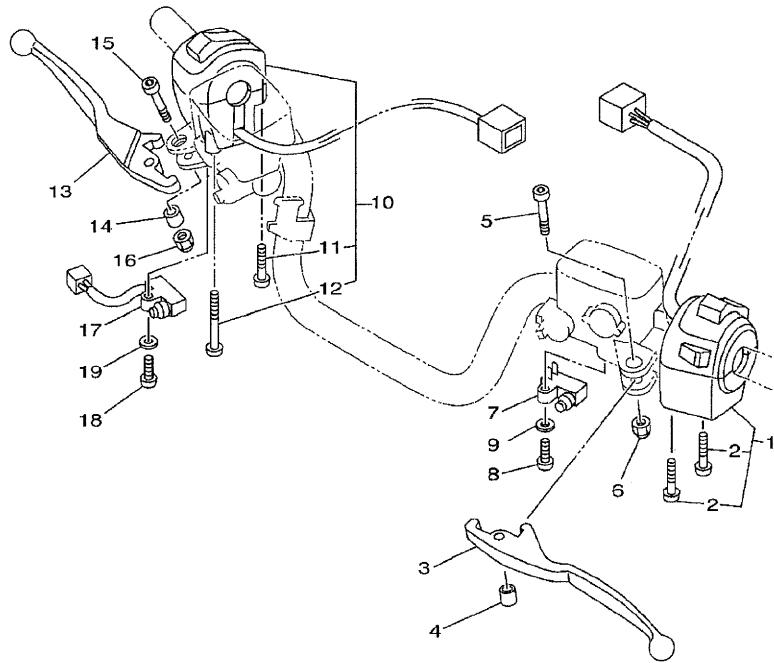

REF. NO.	PART NO.	DESCRIPTION	5GJ5				REMARKS
1	5GJ-83969-00	SWITCH, HANDLE 5	1				
2	98507-05025	.SCREW, PAN HEAD	2				
3	5GJ-83912-00	LEVER 1	1				
4	36Y-83913-01	COLLAR, LEVER 1	1				
5	90110-06074	BOLT, HEXAGON SOCKET HEAD	1				
6	95607-06100	NUT, U	1				
7	36Y-83980-01	FRONT STOP SWITCH ASSY	1				
8	98507-04016	SCREW, PAN HEAD	1				
9	92907-04600	WASHER	1				
10	5GJ-83963-00	SWITCH, HANDLE 3 (RIGHT)	1				
11	98507-05030	.SCREW, PAN HEAD	1				
12	98507-05050	.SCREW, PAN HEAD	1				
13	5GJ-83922-00	LEVER 2	1				
14	36Y-83913-01	COLLAR, LEVER 1	1				
15	90110-06074	BOLT, HEXAGON SOCKET HEAD	1				
16	95607-06100	NUT, U	1				
17	36Y-82917-00	SWITCH	1				
18	98507-04016	SCREW, PAN HEAD	1				
19	92907-04600	WASHER	1				



5GJ5300-A430

FIG. 44 ELECTRICAL 1

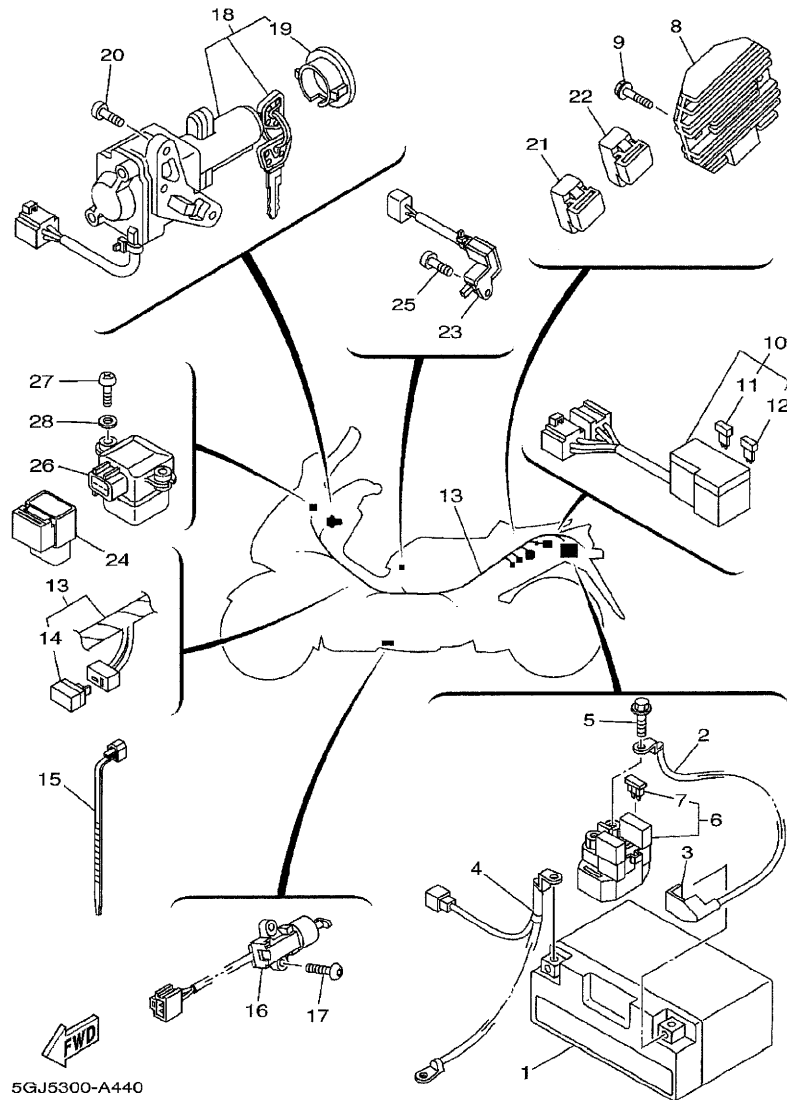

5GJ5300-A440

REF. NO.	PART NO.	DESCRIPTION	5GJ5	REMARKS
1	5GJ-82100-00	BATTERY ASSY	1	
2	5GJ-82115-00	WIRE, PLUS LEAD	1	
3	5GJ-82119-00	COVER, LEAD WIRE	1	
4	5GJ-82116-00	WIRE, MINUS LEAD	1	
5	95027-06008	BOLT, FLANGE	2	
6	4SV-81940-00	STARTER RELAY ASSY	1	
7	1AE-82151-00	.FUSE (30A-BL)	2	
8	4JH-81960-01	RECTIFIER & REGULATOR ASSY	1	
9	95807-06020	BOLT, FLANGE	2	
*10	5GJ-82170-30	FUSE BOX ASSY	1	
11	5JJ-82151-10	.FUSE (15A-BL)	4	
*12	5JJ-82151-30	.FUSE (10A-BL)	5	
*13	5GJ-82590-40	WIRE HARNESS ASSY	1	
14	4WA-81980-00	.DIODE ASSY	1	
15	90464-13073	CLAMP	6	
16	3LD-82566-60	SWITCH, SIDE STAND	1	
17	92017-05014	BOLT, BUTTON HEAD	2	
18	5GJ-82501-00	MAIN SWITCH STEERING LOCK	1	
19	4UC-82552-00	.CAP, SWITCH	1	
20	90149-06002	SCREW	2	
21	4HC-81950-00	RELAY ASSY	1	
*22	29U-81950-93	RELAY ASSY	2	
23	4HC-81860-00	SWITCH ASSY	1	
24	5DM-81950-00	RELAY ASSY	1	
25	98907-03008	SCREW, BIND	1	
26	5GJ-82576-00	EMERGENCY STOP SWITCH ASSY	1	
27	98507-04020	SCREW, PAN HEAD	2	

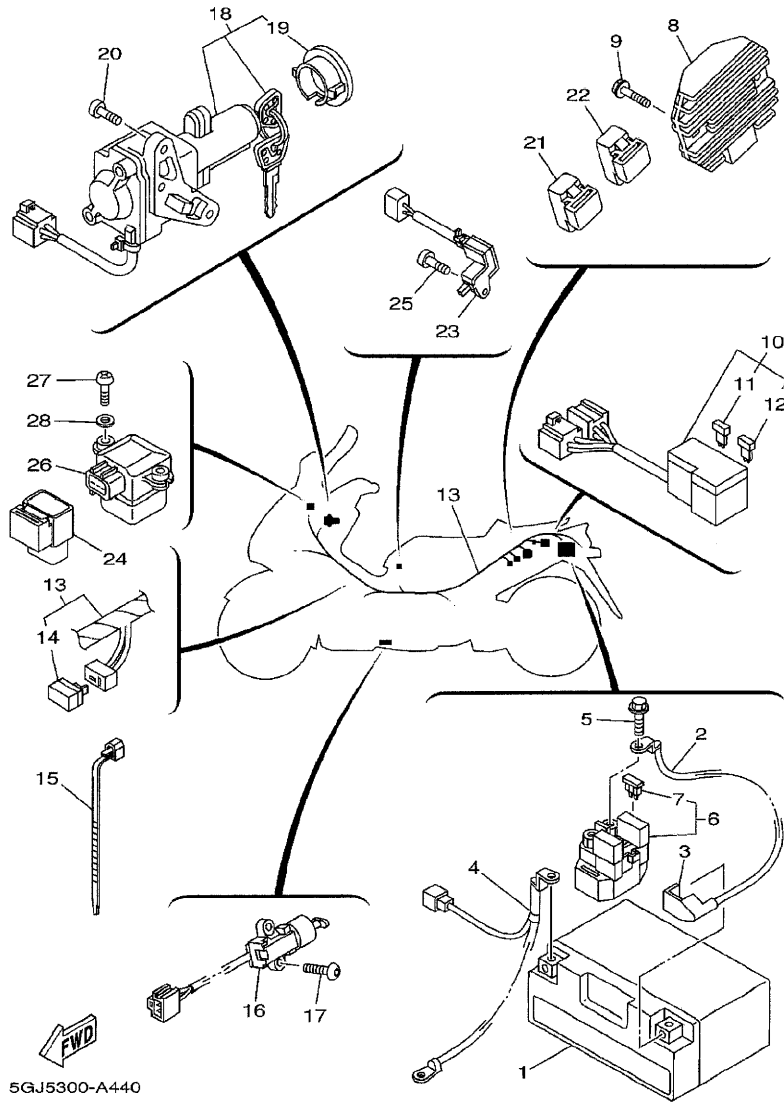

5GJ5300-A440

FIG. 44 ELECTRICAL 1

REF. NO.	PART NO.	DESCRIPTION	5GJ5	REMARKS
28	90201-04325	WASHER, PLATE	2	

FIG. 45 ELECTRICAL 2

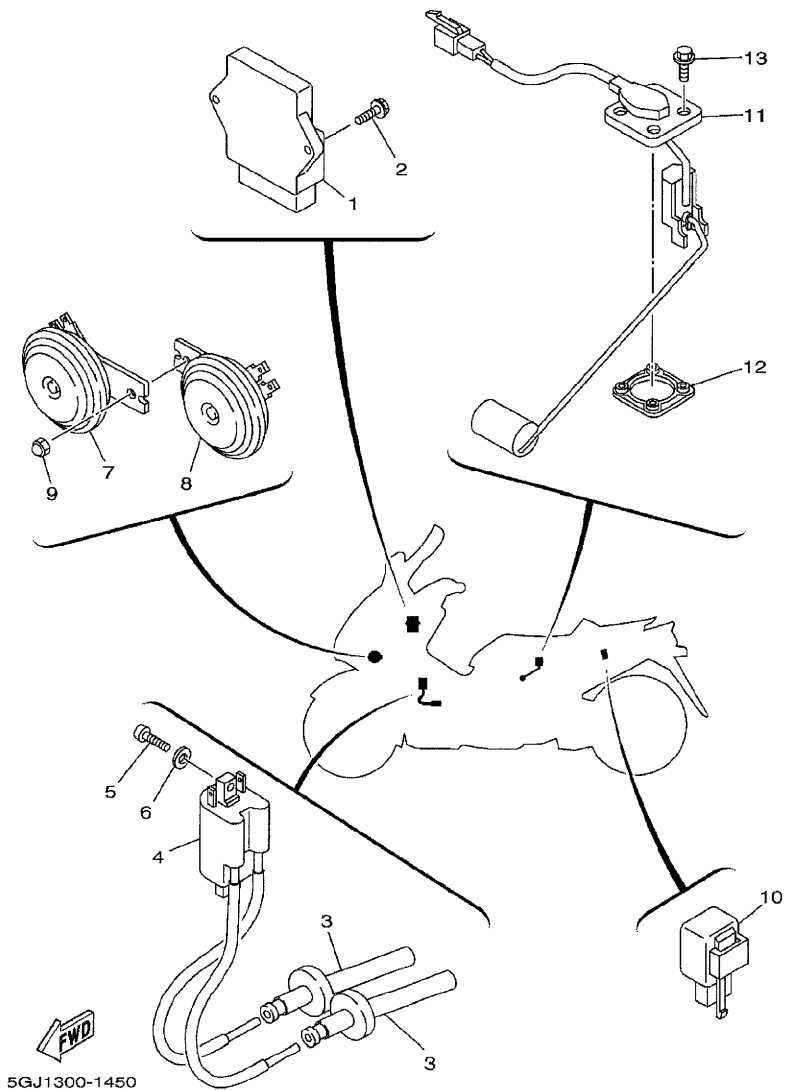

REF. NO.	PART NO.	DESCRIPTION	5GJ5			REMARKS
1	5GJ-82305-00	IGNITOR UNIT ASSY	1			
2	97707-60025	SCREW, TAPPING	2			
3	4XV-82370-01	PLUG CAP ASSY	2			
4	5GJ-82310-00	IGNITION COIL ASSY	1			
5	98507-06020	SCREW, PAN HEAD	2			
6	92907-06600	WASHER, PLATE	2			
7	5JA-83371-00	HORN	1			
8	5GJ-83371-10	HORN	1			
9	90176-06055	NUT, CROWN	1			
10	3GM-83350-01	FLASHER RELAY ASSY	1			
11	5GJ-85752-00	SENDER UNIT ASSY, FUEL METER	1			
12	5G3-85753-00	GASKET, SENDER UNIT	1			
13	90119-05071	BOLT, WITH WASHER	4			

NUMERICAL INDEX

PART NO.	GRID NO.	PART NO.	GRID NO.	PART NO.	GRID NO.	PART NO.	GRID NO.	PART NO.	GRID NO.	PART NO.	GRID NO.
5GJ-W0041-00	E-7	5GJ-11656-10	B-4	5GJ-12405-00	B-9	5GJ-13596-00	B-12	5GJ-1465R-00	C-2	5GJ-15415-00	C-5
5GJ-W0041-10	E-7	5GJ-11656-20	B-3	46X-12410-00	B-9	3LN-13907-00	D-11	5GJ-1465T-00	C-2	5GJ-15417-00	C-5
4WM-W0045-00	E-3		B-4	5GJ-12413-10	B-9	5GJ-14103-00	B-15	5GJ-14710-00	C-2	5GJ-15418-00	C-13
5GJ-W0046-00	E-5	5GJ-11656-30	B-3	5GJ-12420-00	B-8	5GJ-14105-00	B-14	4BD-14766-00	C-2	5GJ-1542A-00	C-6
3JB-W0047-00	E-3		B-4	5GJ-12421-00	B-8	4HM-14107-20	B-14	5GJ-14799-00	C-2	5GJ-1542B-00	C-6
5GJ-W0047-00	E-5		B-4	5GJ-12422-00	B-8	1HX-14133-00	B-15	5GJ-14808-00	C-2	5GJ-15421-00	C-6
5GM-W0048-00	E-5	5GJ-11660-10	B-4	5GJ-1243A-00	B-9	5GJ-1414N-30	B-14	5GJ-14815-00	C-2	5GJ-15423-00	C-6
51L-W0048-00	E-3	4GY-12113-00	B-5	5GJ-1243E-00	B-9	1NT-14142-22	B-14	1TA-14840-00	C-3	5GJ-15431-00	C-6
3YX-W0057-00	E-3	1HX-12118-00	B-5	5GJ-1243F-00	B-9	36Y-14147-00	B-15	5GJ-14871-00	C-2	5GJ-15451-00	C-5
5GJ-W0057-01	E-5	4TV-12119-00	B-5	11H-12438-10	B-8	5GJ-14147-00	B-14	5GJ-14873-01	C-2	5GJ-15453-00	C-5
5GJ-W1141-00	B-3	5GJ-12121-00	B-5	1WG-12439-00	B-8	822-14147-00	B-15	5GJ-14875-00	C-2	5GJ-15461-00	C-6
5GJ-Y283P-50	F-2	5EB-12126-00	B-5	5GJ-1244G-00	B-10	5GJ-14149-00	B-15	5GJ-14876-00	C-3	5GJ-15473-00	C-6
5GJ-11101-00	B-2	5EB-12127-00	B-5	5GJ-12450-00	B-8	137-14153-00	B-14	5EL-1490H-00	B-14	5GJ-15474-00	C-6
5GJ-11166-00	B-2	5EB-12153-09	B-6	5GJ-12461-00	B-9	537-14186-00	B-14	5GJ-1490J-00	B-14	3KJ-15481-00	C-5
5GJ-11181-00	B-2	5EB-12153-20	B-6	4JH-12462-00	B-9	12R-14191-00	B-15	5GJ-14900-20	B-14		C-6
5GJ-11190-00	B-2	1HX-12168-A0	B-5	5GJ-12467-00	B-9	5GJ-14197-00	B-15	5GJ-14901-20	B-14		C-13
5GJ-11193-00	B-2	1HX-12168-F0	B-5	5GJ-12476-00	B-9	5GJ-14197-30	B-15	5GJ-14902-20	B-14	5GJ-15481-00	C-4
5GJ-11195-00	B-2	1HX-12168-H1	B-5	5GJ-12477-00	B-9	620-14212-00	B-15	5GJ-14919-00	B-15	5GJ-15482-00	C-7
214-11198-01	C-4	1HX-12168-K1	B-5	5GJ-12481-00	B-8	620-1423A-71	B-14	1WG-14922-00	B-15	5GJ-15486-00	C-5
812-11198-00	C-13	1HX-12168-M1	B-5	5GJ-12482-00	B-8	3G2-14231-17	B-14	4VR-14933-00	B-14	5GJ-15492-00	C-6
5GJ-11311-00	B-2	1HX-12168-R1	B-5	5GJ-12483-00	B-9	1WG-14251-00	B-15	14X-14937-00	B-15	5GJ-15499-00	C-6
5GJ-11312-00	B-4	1HX-12168-U1	B-5	5GJ-12484-00	B-9	4BR-14251-00	B-2	3UH-14945-00	B-14	5GJ-15512-00	C-8
5GJ-11351-00	B-2	1HX-12168-W1	B-5	5GJ-12485-00	B-9	5AP-14280-00	B-14	5GJ-14945-00	B-14	5GJ-15517-00	C-8
5GJ-11416-A0	B-3	1HX-12168-Y1	B-5	5GJ-12491-00	B-10	5GJ-14294-00	D-11	4G0-14985-00	B-14	36Y-15521-01	C-8
5GJ-11416-00	B-3	1HX-12168-00	B-5	5GJ-12551-00	B-10	5GJ-14348-00	B-15	22F-14991-00	B-14	4NK-15590-00	C-8
5GJ-11416-10	B-3	1HX-12168-20	B-5	5GJ-12552-10	B-10	5GJ-14349-00	B-15	5GJ-14993-00	B-14	5GJ-15789-00	C-6
5GJ-11416-20	B-3	1HX-12168-40	B-5	5GJ-12576-10	B-10	5GJ-14389-00	B-15	5GJ-15100-00	C-4	5GJ-16110-00	C-9
5GJ-11416-30	B-3	1HX-12168-60	B-5	5GJ-12588-10	B-10	5GJ-1440F-00	B-12	5GJ-15113-00	C-6	5GJ-16139-00	C-13
5GJ-11416-40	B-3	1HX-12168-80	B-5	5GJ-12589-10	B-10	5GJ-1440G-00	B-12	36Y-15189-00	C-5	5GJ-16151-00	C-12
5GJ-11417-A0	B-3	1HX-12169-E0	B-5	5GJ-12591-00	B-9	5GJ-1441A-00	B-12	4H7-15189-00	C-4	5GJ-16321-00	C-9
5GJ-11417-00	B-3	1HX-12169-G0	B-6	5GJ-12611-00	B-9	5GJ-14411-00	B-12	5GJ-15191-00	C-6	5GJ-16324-00	C-9
5GJ-11417-10	B-3	1HX-12169-J0	B-6	5GJ-12620-00	B-9	5GJ-14412-00	B-12	5GJ-1531A-00	C-14	5GJ-16325-00	C-9
5GJ-11417-20	B-3	1HX-12169-L0	B-6	5GJ-12675-00	B-9	5GJ-14431-00	B-12	5GJ-15316-00	C-6	5GJ-16334-00	C-9
5GJ-11417-30	B-3	1HX-12169-N0	B-6	5GJ-12682-00	D-11	5GJ-14432-00	B-12	5GJ-15326-00	C-5	5GJ-16371-00	C-9
5GJ-11417-40	B-3	1HX-12169-T0	B-6	3LD-13113-00	B-11	5GJ-14437-00	B-12	5GJ-15335-00	C-13	5GJ-16510-10	C-9
5GJ-11455-10	B-3	1HX-12169-11	B-5	5GJ-13161-00	B-11	4BH-14451-00	B-12	5GJ-15337-00	C-5	5GJ-16520-00	C-9
5GJ-11456-00	C-13	1HX-12169-31	B-5	5GJ-13300-00	B-11	3KJ-14452-30	B-12	5GJ-15338-00	C-13	5GJ-16529-00	C-9
5GJ-11603-00	B-3	1HX-12169-50	B-5	5GJ-13405-00	B-11	4KN-14452-00	B-12	2H7-15361-00	C-5	5GJ-16533-00	C-9
5GJ-11631-00	B-3	1HX-12169-70	B-5	5GJ-13410-00	B-11	48U-14452-00	C-6	5GJ-15362-01	C-14	5GJ-16537-00	C-9
5EB-11633-00	B-3	1HX-12169-90	B-5	22F-13411-01	B-11	5GJ-14453-00	B-12	5GJ-15363-00	C-5	5GJ-16537-10	C-9
5GJ-11642-10-A0	B-3	5GJ-12170-00	B-7	5DM-13440-00	B-11	5GJ-14455-00	C-6	3ES-15371-00	C-14	5GJ-16537-20	C-9
5GJ-11650-00	B-3	5GJ-12180-00	B-7	5GJ-13470-10	B-11	5GJ-14456-00	C-6	4HC-15371-00	C-13	5GJ-16537-30	C-9
4X7-11654-01	B-4	5GJ-12210-00	B-7	4JH-13473-00	B-11	59V-14457-00	B-13	4XM-15383-00	C-10	5GJ-16539-10	C-9
5GJ-11654-00	B-3	4FM-12213-00	B-7	5GJ-13475-00	B-11	1JK-14462-00	B-12	5GJ-15383-00	C-11	5GJ-16540-00	C-9
5GJ-11654-10	B-3	5BE-12241-00	B-7	4G0-13490-01	B-11	5GJ-14463-00	B-12	5GJ-15407-00	C-6	5GJ-16550-00	C-9
5GJ-11656-00	B-3	5GJ-12251-00	B-7	5GJ-13542-00	C-3	4WM-14565-00	B-15	5GJ-15408-00	C-6	5GJ-17111-00	C-12
	B-4	5GJ-12252-00	B-7	5GJ-13575-00	B-12	4BR-14613-00	C-2	5GJ-15411-00	C-5	5GJ-17211-00	C-12
5GJ-11656-10	B-3	5AH-1240G-00	B-10	5GJ-13586-00	B-12	5GJ-14629-00	C-2	5GJ-15414-00	C-5	5GJ-17411-00	C-12

NUMERICAL INDEX

PART NO.	GRID NO.	PART NO.	GRID NO.	PART NO.	GRID NO.	PART NO.	GRID NO.	PART NO.	GRID NO.	PART NO.	GRID NO.
5GJ-17421-00	C - 12	5GJ-21711-00-P3	D - 4	3XC-23135-00	D - 9	5GJ-2473R-00	D - 14	4TX-25852-00	E - 7	4X4-27114-00	E - 9
5GJ-17451-00	C - 13	5GJ-21716-00	D - 5	5GJ-23136-20	D - 9	5GJ-2473T-00	D - 12	3YX-25854-00	E - 7	5GJ-27151-00	E - 9
5GJ-17452-00	C - 13	5GJ-21717-00	D - 5	5GJ-23141-00	D - 9	5GJ-2473W-00	D - 14	3RW-25867-00	E - 7	5GJ-27152-00	E - 9
5GJ-17459-00	C - 13	5GJ-2172W-00-P0	D - 5		D - 10	5GJ-2473W-10	D - 14	5GJ-2587A-00	C - 14	5GJ-27311-00	E - 9
5GJ-17469-00	C - 13	5GJ-21721-00-AL	D - 4	3LN-23142-00	D - 9	5GJ-24730-00	D - 12	5GJ-2587A-10	C - 14	4BP-27413-00	E - 9
5GJ-17523-00	C - 13	5GJ-21721-00-P1	D - 4		D - 10	5GJ-24737-00	D - 14	5GJ-25870-00	E - 7		E - 10
5GJ-17524-00	C - 13	5GJ-21721-00-P2	D - 4	5GJ-23144-00	D - 9	5GM-2474E-00	D - 13	5GJ-25870-10	E - 7	5GJ-27414-00	D - 14
5GJ-17541-00	C - 13	5GJ-21721-00-P3	D - 4		D - 10	5GJ-24741-00	D - 12	5GJ-25872-00	E - 7	36Y-27424-00	C - 2
5GJ-17542-00	C - 13	5GJ-2173B-00	D - 4	5GJ-23145-00	D - 9		D - 15	5GJ-25875-00	E - 7	5GJ-27430-00	E - 9
5GJ-17554-00	C - 13	5GJ-21731-00	D - 5		D - 10	5GJ-24747-00	D - 14	5GJ-25875-10	E - 7	2NT-27437-00	E - 9
5GJ-17611-00	C - 10	5GJ-2174X-00	E - 11	3LN-23151-00	D - 9	5GJ-24748-00	D - 12	5GJ-25876-00	E - 7		E - 10
5GJ-17620-00	C - 10	5GJ-2174Y-00	E - 11	1UF-23156-00	D - 9	5GJ-2475M-00	D - 12	5GJ-25886-00	D - 8	5GJ-27440-00	E - 10
5GJ-17623-00	C - 10	5GJ-21741-00-AL	D - 4		D - 10	5GJ-24754-00	D - 12	5GJ-25886-10	E - 8	5GJ-27445-00	D - 14
5GJ-17632-00	C - 10	5GJ-21741-00-P1	D - 4	3LN-23157-00	D - 9	4HC-24758-00	D - 12	5GJ-25887-00	D - 8	5GJ-27463-00	E - 11
5GJ-17639-00	C - 10	5GJ-21741-00-P2	D - 4		D - 10	5GJ-2476U-00	D - 14	3YX-25896-00	E - 7	5GJ-27481-00	E - 11
5GJ-17641-00	C - 10	5GJ-21741-00-P3	D - 4	5GJ-23171-00	D - 9	5GJ-2476V-00	D - 14	4TT-25914-00	E - 3	5GJ-27483-00	E - 11
4WV-17644-00	C - 10	5GJ-21746-00	E - 11	3LN-23173-00	D - 9	5GJ-24762-00	D - 12	5GM-25914-00	E - 5	5GJ-27484-00	E - 11
5GJ-17645-00	C - 10	56J-21747-00	E - 15		D - 10	5GJ-2477A-00	D - 12	5GJ-25915-00	E - 5	5GJ-27488-00	E - 11
5GJ-17649-00	C - 10	4JP-21753-00	D - 11	5GJ-2331E-00	D - 8	5GJ-2477F-00	D - 12	4BP-25919-00	E - 3	5GJ-28100-00	D - 15
5GJ-17653-00	C - 10	5GJ-2177M-00	E - 12	5GJ-2331G-00	D - 9	5GJ-24773-00-P0	D - 14	4TT-25919-00	E - 5	5GJ-28219-00	E - 13
5GJ-17660-00	C - 10	5GJ-2177N-00	E - 12		D - 10	5GJ-24774-00	D - 12	5GJ-25926-00	E - 5	5GJ-28229-00	E - 13
4CW-17664-00	C - 10	5GJ-21780-00	E - 13	4YR-23317-00	E - 3	5GJ-2477E-00	D - 14	3YX-25929-00	E - 3	5GJ-28267-00	E - 13
5GJ-17670-00	C - 10	5GJ-21796-00	E - 13	5GJ-23340-00	D - 10	5GJ-2478G-00	D - 12	4TT-25937-00	E - 3	5GJ-28307-00	E - 13
5GJ-17681-00	C - 11	1AA-21815-00	D - 5	5GJ-23377-00	D - 10	5GM-24780-01	D - 14		E - 5	5GJ-28311-00	E - 13
5GJ-17690-00	C - 10	5GJ-21816-00	D - 5	1W1-23416-00	D - 8	5GJ-24790-00	D - 12	5GJ-26110-02	E - 6	5GJ-28313-00	E - 13
5GJ-17818-01	C - 13	5GJ-21871-00	D - 5	26H-23418-01	D - 8	5GJ-24792-00	D - 12	5GJ-26143-00	E - 6	5GJ-2832F-00	C - 15
5GJ-21110-00	C - 15	1AA-21874-00	D - 5	5GJ-23435-00	D - 8	5GJ-24854-00	D - 15	5GJ-26144-01	E - 6	5GJ-28345-00-P0	E - 15
5GJ-2117G-00	C - 15	5GJ-2197J-00	D - 12	4H7-23441-10	D - 8	5GJ-25118-00	E - 2	5GJ-26219-00	E - 6	5GJ-28347-00	E - 15
46X-21376-00	D - 15	1J7-22141-00	D - 7	3FV-23462-00	D - 8	5GJ-25168-00-33	E - 2	5GJ-26240-00	E - 6	5GJ-2835U-00-33	E - 14
4HC-21398-00	D - 15	1J7-22143-00	D - 7	5GJ-24110-00	D - 11	5GJ-25181-10	E - 2	4YR-26241-01	E - 6	5GJ-2835V-00-33	E - 14
5GJ-21459-00	C - 15	5GJ-22171-00-35	D - 7	5GJ-2414A-01	D - 11	5GJ-25183-10	E - 2	2T5-26244-00	D - 15	5GJ-28350-00-AL	E - 15
5GJ-21511-00-0X	D - 3	4BH-2219X-00	D - 7	5GJ-2414H-01	D - 11	5GJ-25338-00-33	E - 4	5GJ-26246-00	E - 6	5GJ-28350-00-P1	E - 15
5GJ-21511-00-2X	D - 3	5GJ-22210-20	D - 7	5GJ-24145-00	D - 11	5GJ-25366-00	E - 4	2T5-26261-02	D - 14	5GJ-28350-00-P2	E - 15
5GJ-21511-00-3X	D - 3	5GJ-22243-00	D - 7	5GJ-24217-00	D - 12	5GJ-25367-00	E - 4	2T5-26262-00	D - 14	5GJ-28350-00-P3	E - 15
5GJ-21511-00-4X	D - 3	5GJ-22426-00	D - 7	5GJ-24311-00	D - 11	5GJ-25377-00	E - 4	2T5-26267-00	D - 15	5GJ-28356-10	C - 15
5GJ-21512-00	D - 10	5GJ-22465-00	E - 8	5GJ-24312-00	D - 11	5GJ-25381-00	E - 4	2T5-26273-00	D - 14	5GM-2836B-01	E - 15
3VP-21535-00	E - 15	5GJ-23102-20	D - 9	5GJ-24318-00	D - 11	5MT-25398-00	E - 2	2T5-26274-00	D - 14	5GJ-2836K-01	E - 15
5GJ-21552-00	D - 3	5GJ-23103-20	D - 9	3H3-24376-00	B - 15		E - 4	5GJ-26280-10	E - 15	5GJ-2836L-00	E - 15
5GJ-21553-00	D - 3	5GJ-23110-00	D - 9	5GJ-24398-00	D - 11	5MT-25398-10	E - 2	5GJ-26290-10	E - 15	4HC-2837G-00	F - 5
5GJ-21587-00	D - 2	3LN-23111-00	D - 9	5GJ-24411-00	B - 14		E - 4	5GJ-26311-03	E - 6	5GJ-28371-00	E - 13
5GJ-21629-00	D - 5		D - 10	1FK-24560-10	D - 11	5MT-25398-20	E - 2	5GJ-26312-03	E - 6	5GJ-28376-00	F - 2
5GJ-2171E-00	E - 13	1UF-23115-00	D - 9	3KJ-24602-03	D - 11		E - 4	304-26329-00	D - 15	5GJ-2839M-00	D - 14
5GJ-2171L-00-P0	E - 12		D - 10	5GJ-2470F-00	D - 12	5GJ-2580T-00	E - 3	58E-26329-00	D - 15	5GJ-28455-10	F - 2
5GJ-2171M-00-P0	E - 12	3LN-23118-00	D - 9	5GJ-24723-00	D - 5	5GJ-2580V-01	E - 5	5GJ-26367-00	D - 15	5GJ-28455-20	F - 2
5GJ-2171X-00-P0	D - 5		D - 10		D - 14	5GJ-2582T-00	E - 3	5GJ-2639E-00	D - 15	5GJ-2846K-00	E - 14
5GJ-21711-00-AL	D - 4	3XC-23125-00	D - 9		F - 2	3GM-2582W-A0	E - 5	3J0-26393-00	D - 15	5GJ-46153-00	C - 14
5GJ-21711-00-P1	D - 4		D - 10	5GJ-24724-00	D - 5	5GJ-25827-00	E - 5	5GJ-27111-01	E - 9	5GJ-81410-00	F - 3
5GJ-21711-00-P2	D - 4	5GJ-23126-20	D - 9	5GJ-2473F-00	D - 12	5GJ-2584A-00	E - 7	116-27114-00	C - 15	5GJ-81450-00	F - 3

NUMERICAL INDEX

PART NO.	GRID NO.	PART NO.	GRID NO.	PART NO.	GRID NO.	PART NO.	GRID NO.	PART NO.	GRID NO.	PART NO.	GRID NO.
5GJ-81815-00	C-8	5GJ-83510-30	F-5	90105-06690	F-7	90150-05024	F-2	90201-06008	E-15	90401-20170	B-11
4XV-8182A-00	C-8	5GJ-83511-00	F-5	90105-10200	E-4	90151-06001	C-10	90201-08088	D-14	90413-08012	B-10
3HE-81826-00	C-8	1YT-83517-00	F-5	90105-10388	E-9	90154-06014	D-3	90201-081E6	D-9	90430-08119	B-2
3HE-81840-00	C-8	4R0-83517-00	F-5	90105-105A7	E-3	90157-05079	E-9		D-10		C-4
11H-81844-00	C-8	3SX-8352K-00	F-5	90105-10638	E-5		E-10	90201-087F0	C-15	90445-09094	D-5
1FK-81847-00	C-8	5GJ-8353H-00	F-5	90105-12007	D-7	90159-05028	E-6	90201-090P4	B-2	90450-32015	B-9
4HC-81860-00	F-9	46X-83591-00	B-2	90105-12106	C-15	90167-03004	D-15	90201-10118	E-7	90460-56071	B-12
5GJ-81890-00	C-8	5GJ-83612-00	F-5	90105-12760	C-15	90167-05076	D-4		E-8		B-13
4SV-81940-00	F-9	5GJ-83612-20	F-5	90109-060F3	D-3		D-5	90201-10430	C-15	90462-05005	F-4
29U-81950-93	F-9	5GM-83616-00	F-5	90109-06036	D-14		E-12	90201-10669	C-2		F-6
4HC-81950-00	F-9	5GM-8362Y-00	F-5	90109-063F1	D-14	90167-05077	E-13	90201-122F8	D-7	90462-20188	C-3
5DM-81950-00	F-9	5GM-83740-00	F-5	90109-063F5	D-12	90167-05079	D-4	90201-141A3	E-4	90464-07001	C-15
4JH-81960-01	F-9	5RB-83740-00	F-5	90109-064G6	E-3		D-5	90201-20272	C-12	90464-07209	D-5
4WA-81980-00	F-9	5GJ-83755-00	E-2		E-5		E-6	90201-220T0	D-7	90464-08189	C-15
5GJ-82100-00	F-9	2XF-83781-V0	F-5	90109-101E6	E-9		E-11	90201-25290	C-8	90464-09008	D-2
5GJ-82115-00	F-9	5GJ-83912-00	F-8	90109-10474	E-9		E-14	90202-24190	D-8	90464-09129	E-8
5GJ-82116-00	F-9	36Y-83913-01	F-8	90110-05007	F-3		E-15	90202-26142	D-8	90464-10190	C-15
5GJ-82119-00	F-9	5GJ-83922-00	F-8	90110-06004	B-11	90167-05080	D-5	90206-10036	D-12		D-2
1AE-82151-00	F-9	5GJ-83963-00	F-8	90110-06017	F-3		E-6	90209-05347	D-4	90464-12089	D-2
5JJ-82151-10	F-9	4HC-83964-00	F-5	90110-06021	B-2	90170-16326	C-9	90240-04002	E-13	90464-12238	B-10
5JJ-82151-30	F-9	5GJ-83969-00	F-8	90110-06036	C-11	90170-18221	C-11	90269-07076	D-12	90464-13001	B-10
5GJ-82170-30	F-9	36Y-83980-01	F-8	90110-06074	F-8	90170-36279	C-9	90280-05013	B-4	90464-13073	F-9
5GJ-82305-00	F-11	5GJ-84310-00	F-6	90110-06200	D-4		C-10	90338-06143	D-4	90464-13077	C-15
5GJ-82310-00	F-11	5GJ-84310-10	F-6		D-5	90176-06055	F-11	90338-16004	E-2	90464-13249	D-2
5GJ-82316-00	C-15	4XV-84312-00	F-6	90110-08N51	D-9	90176-10075	C-2	90338-20113	E-13	90464-15192	C-15
4XV-82370-01	F-11	5GJ-84312-00	F-7		D-10	90179-05523	F-2	90340-12059	C-13	90464-18246	D-2
5GJ-82501-00	F-9	4SV-84314-00	F-6	90110-08004	C-4	90179-07652	B-3	90381-12047	D-7	90464-25217	C-15
4UC-82552-00	F-9	8G9-84314-00	F-6	90110-08005	C-8	90179-09379	B-4	90387-061F9	E-11	90464-60067	E-8
5GH-82560-00	B-10	4HC-84347-00	D-14	90111-05002	D-5	90179-09489	B-2	90387-064H8	E-9	90465-08371	B-12
5GJ-82560-00	B-10	4SV-84347-00	F-6		D-14	90179-09612	B-2		E-10	90465-14310	E-8
3LD-82566-60	F-9	5GJ-84359-00	F-6		E-13	90179-18002	B-4	90387-066R8	D-5	90467-07138	C-3
5GJ-82576-00	F-9	5GJ-84359-10	F-6	90111-05012	C-10	90179-20002	C-10		E-11	90467-08003	D-6
5GJ-82590-40	F-9	5GJ-84397-00	F-6	90111-06009	D-15	90179-22412	D-8	90387-067V1	B-12	90467-08092	C-3
36Y-82917-00	F-8	5GJ-84516-00	F-7		E-11	90179-25033	D-8		B-13	90467-09120	B-9
5GJ-8331E-00	F-4	5GJ-84523-00	F-7	90111-06015	C-2	90183-05042	D-3	90387-07003	E-15	90467-10008	D-6
5GJ-83310-00	F-4	5GJ-84710-00	F-7	90111-06020	C-2		D-4	90387-071E0	E-15	90467-10035	B-9
5GJ-83320-00	F-4	36Y-84714-40	F-7	90111-10002	B-4		D-5	90387-0714B	B-10	90467-12053	B-10
32H-83331-00	F-7	5GJ-84721-00	F-7	90116-06475	B-2		E-6	90387-07717	F-7		D-11
5GJ-83331-00	F-4	25G-84742-00	F-7	90116-09584	B-2		E-11	90387-10636	C-2	90467-13062	D-11
5GJ-83332-00	F-7	25G-84743-01	F-7	90119-05071	F-11		E-13	90387-12003	D-7	90467-13071	B-2
5GJ-83342-00	F-7	5GJ-84744-00	F-7	90119-06020	B-7		E-14	90387-1508E	E-2	90467-15141	B-9
3GM-83350-01	F-11	4HC-84770-00	D-14	90119-06060	D-5		E-15	90387-16008	D-7	90467-16181	B-2
5GJ-83371-10	F-11	3Y6-85130-02	F-7		E-11		F-7	90387-173M5	E-4	90467-19065	C-2
5JA-83371-00	F-11	5GJ-85752-00	F-11		E-13	90183-05076	D-14	90387-17543	D-7	90467-19160	C-3
5GJ-83500-00	F-5	5G3-85753-00	F-11	90119-06192	C-6	90185-10037	E-9	90387-18001	B-4	90467-22080	B-13
5GJ-83500-30	F-5	4XY-85885-00	B-15	90119-06194	D-11	90185-10091	E-9	90387-1904J	C-9	90467-24096	C-3
5GJ-83509-00	F-5	90101-16002	D-7	90149-06002	F-9	90201-04325	F-10	90387-26001	C-11	90468-10004	E-13
5GJ-83510-00	F-5	90105-06690	D-10	90149-06020	C-5	90201-06008	D-12	90401-10172	E-7	90480-01558	C-15

NUMERICAL INDEX

PART NO.	GRID NO.	PART NO.	GRID NO.	PART NO.	GRID NO.	PART NO.	GRID NO.	PART NO.	GRID NO.	PART NO.	GRID NO.
90480-01558	E- 11	92907-06600	F- 6	93306-30102	C- 10	95607-08200	C- 2	97707-30512	F- 5		
	E- 15		F- 11	93306-30202	E- 2	95607-12200	C- 15	97707-40016	F- 5		
90480-10289	F- 6	92907-08600	D- 7	93306-30206	C- 11		D- 7	97707-40510	E- 13		
90480-10332	C- 2	92990-06200	C- 2	93306-30317	E- 4	95607-14200	E- 4	97707-50012	E- 12		
90480-12497	B- 12	93101-30001	B- 4	93306-30401	C- 12	95617-08620	B- 2		E- 13		
90480-13018	D- 11	93101-35001	C- 10		C- 13	95702-05500	B- 9		E- 14		
90480-13426	D- 5	93102-12442	B- 8	93306-90403	C- 9	95707-05500	F- 7		E- 15		
90480-13567	E- 11	93102-15004	C- 11	93306-90602	B- 4	95707-06500	C- 2		F- 2		
90480-15058	E- 15	93102-22014	E- 2	93317-33179	C- 9		E- 15	97707-50016	F- 4		
90480-16301	B- 10	93102-25017	D- 7	93317-41761	D- 7	95707-08500	D- 12		F- 5		
90480-20280	D- 11	93102-25044	E- 4	93332-00010	D- 7	95807-06010	B- 9	97707-50520	B- 12		
90480-20527	D- 11	93102-25064	C- 12	93332-00086	C- 13		C- 14	97707-60025	F- 11		
90501-05512	D- 15	93102-40080	C- 14	93399-99931	D- 8		C- 15	98507-04006	B- 14		
90501-104F9	B- 11	93102-42004	C- 11	93399-99932	D- 8		D- 2	98507-04012	B- 14		
90501-12743	E- 9	93102-44008	B- 4	93450-16068	B- 4		D- 8	98507-04014	B- 14		
	E- 10	93102-48004	C- 14	93450-17129	B- 3		D- 10	98507-04016	F- 8		
90501-626L9	C- 10	93102-55004	C- 14	93501-04011	E- 9		E- 7	98507-04020	F- 9		
90506-20002	E- 9	93104-41119	C- 10		E- 10		E- 8	98507-05008	B- 14		
90506-23509	E- 9	93105-45017	C- 14	93505-08030	B- 11	95807-06012	B- 9	98507-05010	E- 6		
90506-40508	E- 9	93210-06422	B- 11	93603-50195	D- 12		C- 15	98507-05025	F- 8		
90560-17306	E- 4	93210-09525	B- 11	93608-30152	C- 14		D- 8	98507-05030	F- 8		
91317-06010	C- 2	93210-10096	B- 11	93608-60001	B- 4	95807-06014	D- 5	98507-05050	F- 8		
91317-06020	B- 8	93210-14579	B- 11	93612-16254	B- 2	95807-06016	D- 3	98507-06014	C- 3		
	B- 12	93210-16325	C- 5	93900-00030	E- 2		D- 14	98507-06020	F- 11		
91317-06025	B- 7	93210-19123	C- 5		E- 4		E- 7	98706-04012	E- 7		
	E- 7		C- 14	94112-14008	E- 2		E- 11	98907-03008	F- 9		
91317-06035	B- 2	93210-21190	B- 8	94112-1415B	E- 2	95807-06020	B- 12	98907-05020	D- 5		
91317-08020	C- 13	93210-22382	C- 4	94115-14008	E- 4		B- 13	98980-06010	C- 2		
91317-08025	D- 10	93210-26001	C- 11	94115-14012	E- 4		D- 12	99009-12400	B- 8		
91317-08030	D- 8	93210-30611	C- 10	94580-25058	B- 11		E- 7	99009-25400	C- 12		
91317-08040	D- 10	93210-30694	D- 9	94581-89132	B- 7		F- 9		C- 13		
91317-10030	C- 15		D- 10	94701-00353	B- 2	95807-06025	E- 15	99009-37500	C- 9		
91317-10045	C- 15	93210-32738	B- 12	95024-06035	C- 14	95807-06030	B- 10	99009-42500	C- 11		
91380-06016	C- 2	93210-33133	B- 8	95027-06008	F- 9	95807-08012	E- 8	99246-00080	E- 14		
91401-20012	E- 9	93210-34504	C- 13	95027-06025	B- 9	95807-08016	C- 15	99247-00080	D- 4		
	E- 10	93210-44545	C- 10	95027-06035	C- 4		E- 9	99480-08020	C- 6		
91701-06035	E- 9	93210-44704	E- 4		C- 5		E- 10	99530-10114	C- 4		
	E- 10	93210-48364	C- 4		C- 6	95807-10040	C- 2		C- 5		
92017-05014	F- 9	93210-50553	C- 13	95027-06050	C- 4	95817-06025	C- 8		C- 13		
92017-06012	D- 8	93211-44348	C- 10	95027-06085	B- 2	95817-10100	D- 7	99530-10116	B- 2		
92017-06014	C- 6	93306-00106	B- 8	95027-08012	B- 2	95827-06012	D- 11	99530-14016	D- 7		
92017-06050	B- 11	93306-00708	C- 10	95027-08025	C- 6	97007-05010	D- 15				
92017-08030	D- 14	93306-00803	C- 14	95027-08040	C- 6	97007-06025	F- 6				
92907-04100	B- 14	93306-00804	C- 14	95027-08110	C- 4	97007-08035	D- 7				
	B- 15	93306-20331	E- 4	95307-05600	D- 15	97027-06016	B- 8				
92907-04600	F- 8	93306-20583	C- 12	95607-06100	F- 8	97027-06030	B- 8				
92907-06600	B- 8	93306-20637	C- 13	95607-06200	D- 7	97702-40614	F- 7				
	C- 3	93306-20647	C- 11		D- 12	97707-04108	D- 12				