



PARTS CATALOGUE

XC125 (5MLA) BELGIUM

XC125 (5MLA) EUROPE

XC125 (5MLA) GREECE

XC125 (5MLA) SWEDEN

XC125 (5MLA) UNITED KINGDOM

XC125
PARTS CATALOGUE
©2005 by Yamaha Motor Co., Ltd.
1st edition, September 2005
All rights reserved.
Any reprinting or unauthorized use
without the written permission of
Yamaha Motor Co., Ltd.
is expressly prohibited.

A3

FOREWORD

This Parts Catalogue is related to the parts for the model(s) on the cover page. When you are ordering replacement parts, please refer to this Parts Catalogue and quote both part numbers and part names correctly.

1. Modifications or additions which have been made after the issue of the Parts Catalogue will be announced in the Parts News.

It is advisable that you make the necessary corrections to the Parts Catalogue according to the Parts News.

2. Abbreviations

The following abbreviations are used in this Parts Catalogue.

“UR” Use specified parts number.

“UN” Use as many as needed.

“AP” Alternate Parts

“LM” Locally Made (Parts need to be ordered locally)

“F#” Frame No. (Applicable machine No.)

“O/S” Over Size

3. The number of components for assembly

- Parts, which are to be supplied in an assembly, are listed with a dot (.) in front of the part name as shown below.
- The numeral appearing to the right of each component part indicates the quantity of parts for each assembly unit.

PART NO.	DESCRIPTION	Q'TY	REMARKS
2F5-83310-60	FRONT FLASHER LIGHT ASSY	2	
115-83311-60	.BULB (6V-18W)	1	

4. Applicable colours of graphics are represented in the “REMARKS” as shown below.

PART NO.	DESCRIPTION	Q'TY	REMARKS
2N4-24110-00-X5	FUEL TANK COMP.	2	MXR
3J1-24240-10	.GRAPHIC, FUEL TANK	1	FOR MXR

5. Note that the illustrations for reference in finding parts numbers are not to be used for assembling. When assembling, please use the applicable service manual.

6. The asterisk (*) before a reference number indicates modified items after the first edition.

FOREWORD

7. Applicable Serial No.

Engine Serial No.

Frame Serial No.

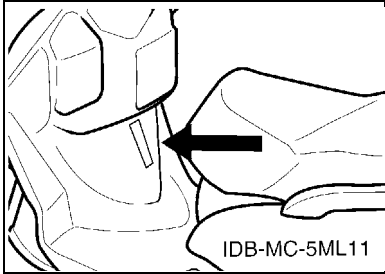
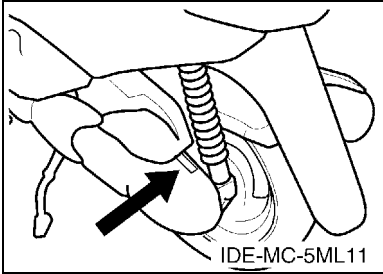

8. Applicable Colour Code (The (*) mark shows Model colour.)

Abbreviation	Colour Name	Colour Code
LGB	LOW GLOSS BLACK	0098
LNBM8(*)	LIGHT GRAYISH BLUE METALLIC 8	0785
MDS(*)	MIDNIGHT SILVER	007M
S1(*)	SILVER 1	0755
SL	SILVER	0035
WM1(*)	WHITE METALLIC 1	0233
YB	YAMAHA BLACK	0033

CONTENTS

ENGINE

CYLINDER HEAD	B2
CRANKSHAFT & PISTON	B4
VALVE	B5
AIR SHROUD & FAN	B6
OIL PUMP	B7
INTAKE	B8
CARBURETOR	B9
EXHAUST	B11
CRANKCASE	B13
STARTER	C2
CLUTCH	C3
TRANSMISSION	C5

CHASSIS

FRAME	C6
FRONT FENDER	C8
SIDE COVER	C9
REAR ARM & SUSPENSION	C11
FRONT FORK	C12
FUEL TANK	C14
SEAT	D2
FRONT WHEEL	D3
FRONT BRAKE CALIPER	D4
REAR WHEEL	D5
STEERING HANDLE & CABLE	D6
FRONT MASTER CYLINDER	D7
STAND & FOOTREST	D8
LEG SHIELD	D9
COWLING 1	D11
GENERATOR	D12
STARTING MOTOR	D13
FLASHER LIGHT	D14
METER	D15
HEADLIGHT	E2
TAILLIGHT	E3
HANDLE SWITCH & LEVER	E4
ELECTRICAL 1	E5

INDEX

NUMERICAL INDEX	M1
-----------------------	----

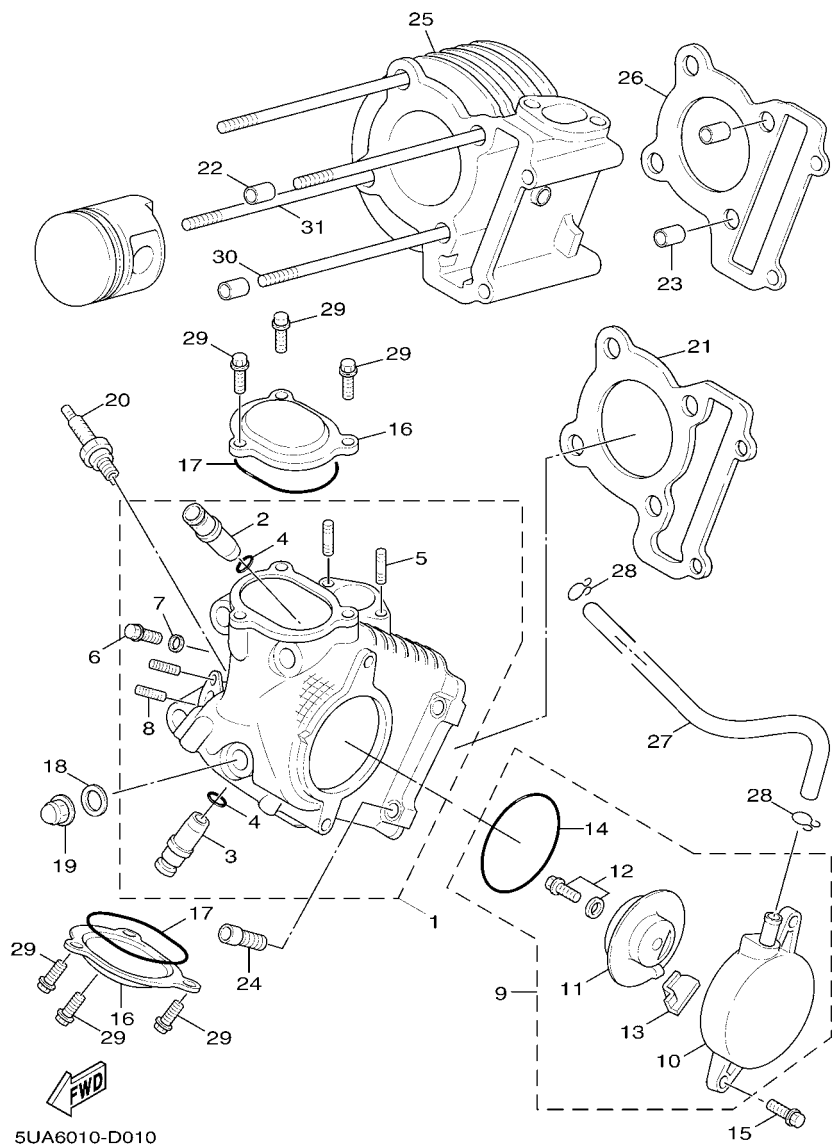

5UA6010-D010

FIG. 1 CYLINDER HEAD

REF. NO.	PART NO.	DESCRIPTION	010	020	030	040	050	REMARKS
1	1P3-E1102-00	CYLINDER HEAD ASSY	1	1	1	1	1	
2	1P3-E1133-10	.GUIDE, VALVE 1	2	2	2	2	2	
3	1P3-E1134-10	.GUIDE, VALVE 2	2	2	2	2	2	
4	93210-09802	.O-RING	4	4	4	4	4	
5	90116-08806	.BOLT, STUD	2	2	2	2	2	
6	90153-06803	.SCREW, HEXAGON	1	1	1	1	1	
7	90430-06014	.GASKET	1	1	1	1	1	
8	90113-06803	.BOLT, SET	2	2	2	2	2	
9	5ML-E1160-00	BREATHER ASSY	1	1	1	1	1	
10	5ML-E1185-00	.COVER, CYLINDER HEAD SIDE 1	1	1	1	1	1	
11	5ML-E1165-00	.PLATE, BREATHER	1	1	1	1	1	
12	97527-06512	.BOLT, WITH WASHER	1	1	1	1	1	
13	4CW-E1155-00	.SEAL, LABYRINTH	1	1	1	1	1	
14	93210-71462	.O-RING	1	1	1	1	1	
15	95027-06020	BOLT, FLANGE	2	2	2	2	2	
16	5ML-E1186-00	COVER, CYLINDER HEAD SIDE 2	2	2	2	2	2	
17	93210-54003	O-RING	2	2	2	2	2	
18	90201-08609	WASHER, PLATE	4	4	4	4	4	
19	90176-08816	NUT, CROWN	4	4	4	4	4	
20	94701-00840	PLUG, SPARK	1	1	1	1	1	
21	5ML-E1181-00	GASKET, CYLINDER HEAD 1	1	1	1	1	1	
22	91810-14807	PIN, DOWEL	2	2	2	2	2	
23	91810-14807	PIN, DOWEL	2	2	2	2	2	
24	91317-06100	BOLT	2	2	2	2	2	
25	5ML-E1311-00	CYLINDER 1	1	1	1	1	1	
26	5ML-E1351-01	GASKET, CYLINDER	1	1	1	1	1	
27	5ML-E4987-00	HOSE	1	1	1	1	1	

FIG. 2 CRANKSHAFT & PISTON

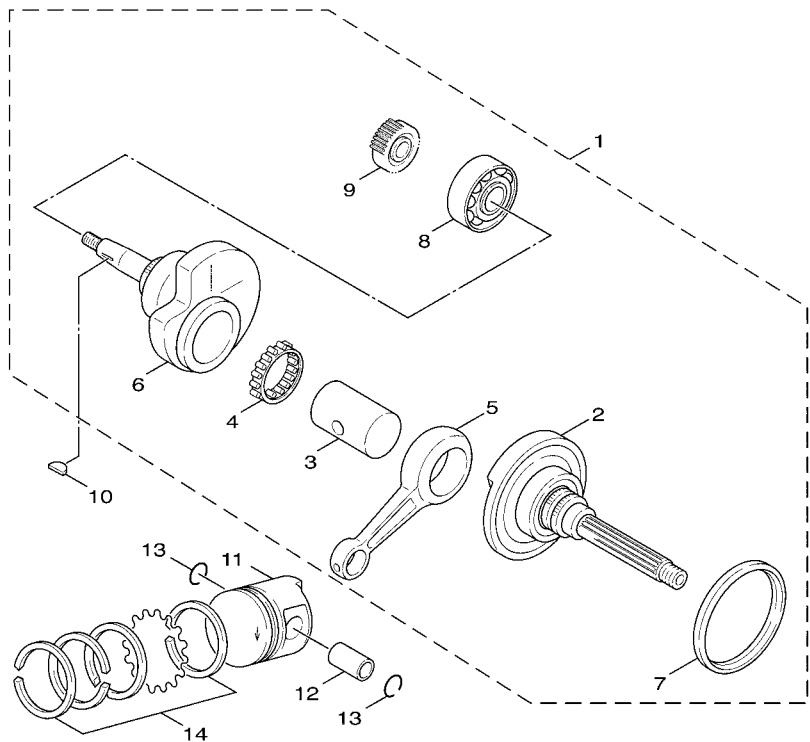

REF. NO.	PART NO.	DESCRIPTION	010	020	030	040	050	REMARKS
1	5ML-E1400-02	CRANKSHAFT ASSY	1	1	1	1	1	
2	5ML-W1141-02	.CRANK 1	1	1	1	1	1	
3	5ML-E1681-00	.PIN, CRANK 1	1	1	1	1	1	
4	93310-528Y9	.BEARING	1	1	1	1	1	
5	5LW-E1651-00	.ROD, CONNECTING	1	1	1	1	1	
6	5ML-E1422-00	.CRANK 2	1	1	1	1	1	
7	5ML-E3452-00	.COVER, ROTOR FILTER	1	1	1	1	1	
8	93306-372Y3	.BEARING	1	1	1	1	1	
9	5ML-E3324-00	.GEAR, PUMP DRIVE	1	1	1	1	1	
10	90280-03045	KEY, WOODRUFF	1	1	1	1	1	
11	5ML-E1631-10	PISTON (STD)	1	1	1	1	1	
12	5LW-E1633-00	PIN, PISTON	1	1	1	1	1	
13	93450-16068	CIRCLIP	2	2	2	2	2	
14	5ML-E1603-00	PISTON RING SET (STD)	1	1	1	1	1	

5TY1414-2020

FIG. 3 VALVE

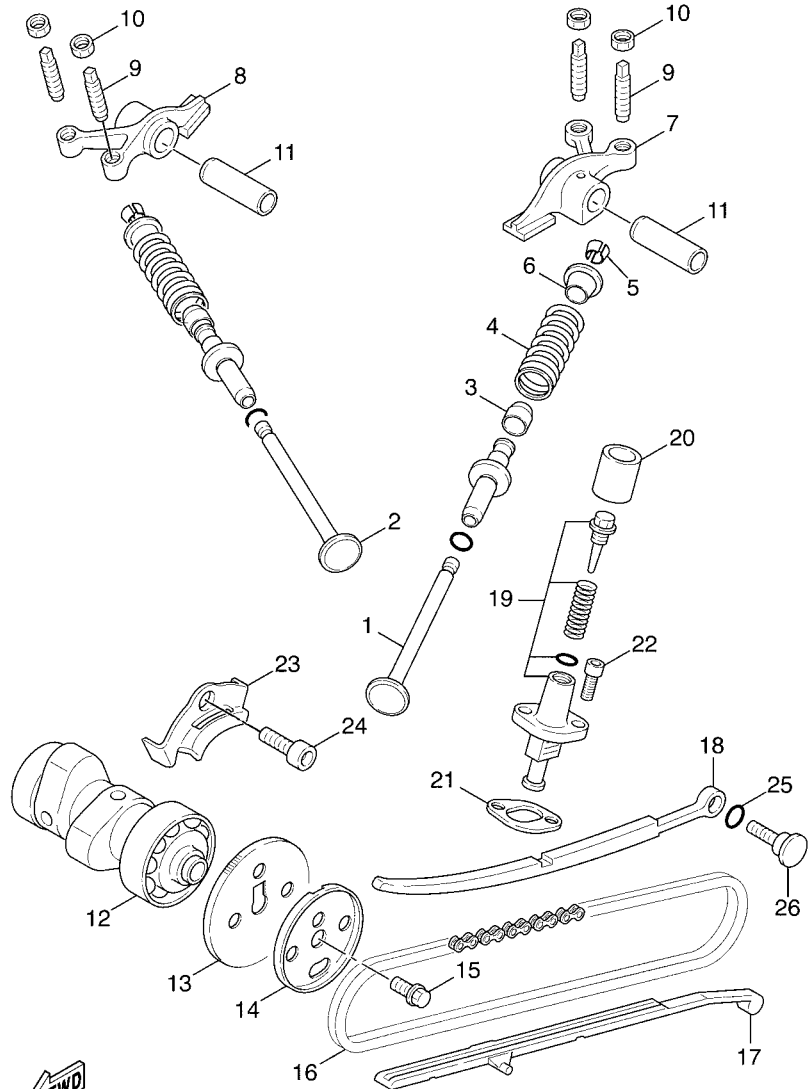

FWD
5TY1414-2030

REF. NO.	PART NO.	DESCRIPTION	010	020	030	040	050	REMARKS
1	5ML-E2111-00	VALVE, INTAKE	2	2	2	2	2	
2	5ML-E2121-00	VALVE, EXHAUST	2	2	2	2	2	
3	5ML-E2119-00	SEAL, VALVE STEM	4	4	4	4	4	
4	5ML-12113-00	SPRING, VALVE INNER	4	4	4	4	4	
5	1AA-12118-00	COTTER, VALVE	8	8	8	8	8	
6	1P3-E2117-00	RETAINER, VALVE SPRING	4	4	4	4	4	
7	1P3-E2151-00	ARM, VALVE ROCKER	1	1	1	1	1	
8	1P3-E2161-00	ARM, VALVE ROCKER 2	1	1	1	1	1	
9	5FM-E2159-00	SCREW, VALVE ADJUSTING	4	4	4	4	4	
10	90170-05800	NUT	4	4	4	4	4	
11	5HK-E2156-00	SHAFT, ROCKER 2	2	2	2	2	2	
12	1P3-E2170-00	CAMSHAFT ASSY 1	1	1	1	1	1	
13	5LW-E2176-00	SPROCKET, CAM CHAIN	1	1	1	1	1	
14	5ML-E1145-00	PLATE, BREATHER 2	1	1	1	1	1	
15	95817-08016	BOLT, FLANGE	1	1	1	1	1	
16	94568-75094	CHAIN	1	1	1	1	1	
17	5ML-E2231-00	GUIDE, STOPPER 1	1	1	1	1	1	
18	5ML-E2241-00	GUIDE, STOPPER 2	1	1	1	1	1	
19	5ML-E2210-00	TENSIONER ASSY, CAM CHAIN	1	1	1	1	1	
20	5UA-E2232-00	DAMPER	1	1	1	1	1	
21	4DH-E2213-01	GASKET, TENSIONER CASE	1	1	1	1	1	
22	91317-06016	BOLT	2	2	2	2	2	
23	5ML-E111F-00	PLATE	1	1	1	1	1	
24	91317-06012	BOLT	1	1	1	1	1	
25	93210-15862	O-RING	1	1	1	1	1	
26	4CW-E2157-00	BOLT	1	1	1	1	1	

FIG. 4 AIR SHROUD & FAN

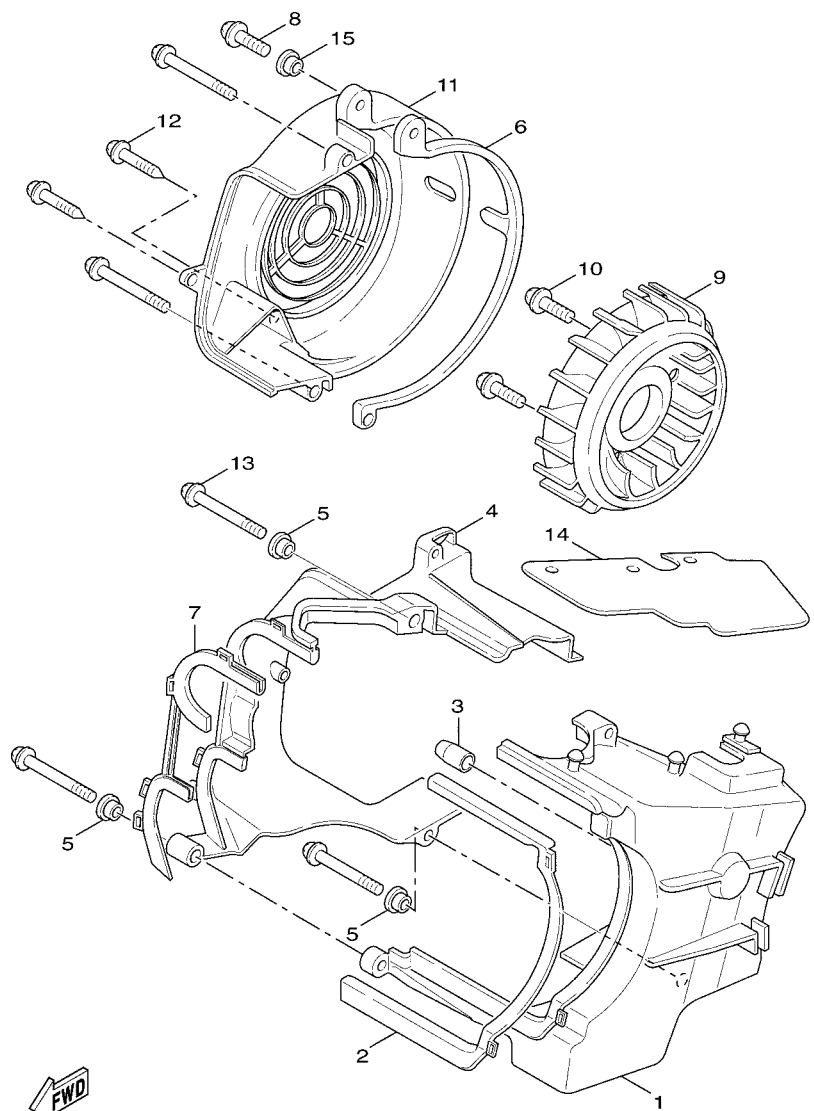

5TY1414-2040

REF. NO.	PART NO.	DESCRIPTION	010	020	030	040	050	REMARKS
1	5ML-E2651-00	AIR SHROUD, CYLINDER 1	1	1	1	1	1	
2	5ML-E2668-00	DAMPER, AIR SHROUD 3	1	1	1	1	1	
3	3KW-E3569-00	PLUG, BLIND	1	1	1	1	1	
4	5ML-E2652-00	AIR SHROUD, CYLINDER 2	1	1	1	1	1	
5	90387-068F9	COLLAR	3	3	3	3	3	
6	5ML-E2658-00	DAMPER, AIR SHROUD 1	1	1	1	1	1	
7	5ML-E2659-00	DAMPER, AIR SHROUD 2	1	1	1	1	1	
8	97707-60530	SCREW, TAPPING	5	5	5	5	5	
9	5UA-E2611-00	FAN	1	1	1	1	1	
10	90119-06857	BOLT, WITH WASHER	4	4	4	4	4	
11	5ML-E2653-01	AIR SHROUD, CYLINDER 3	1	1	1	1	1	
12	97707-60516	SCREW, TAPPING	1	1	1	1	1	
13	97607-06220	SCREW, WITH WASHER	3	3	3	3	3	
14	5ML-E2682-00	PROTECTOR, HEAT	1	1	1	1	1	
15	90480-12497	GROMMET	1	1	1	1	1	

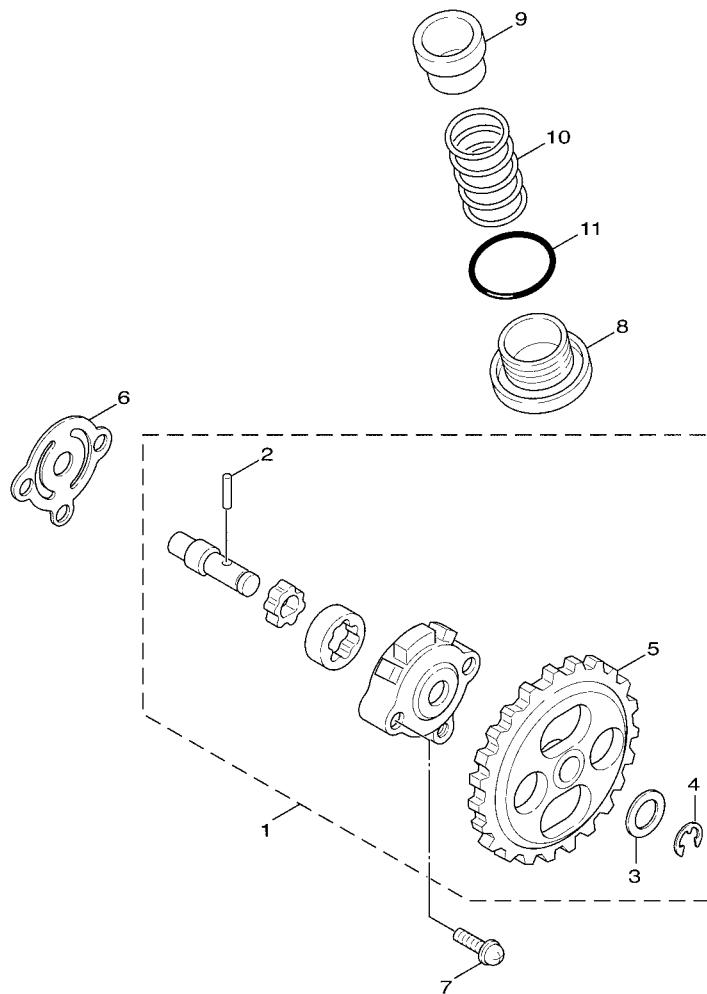
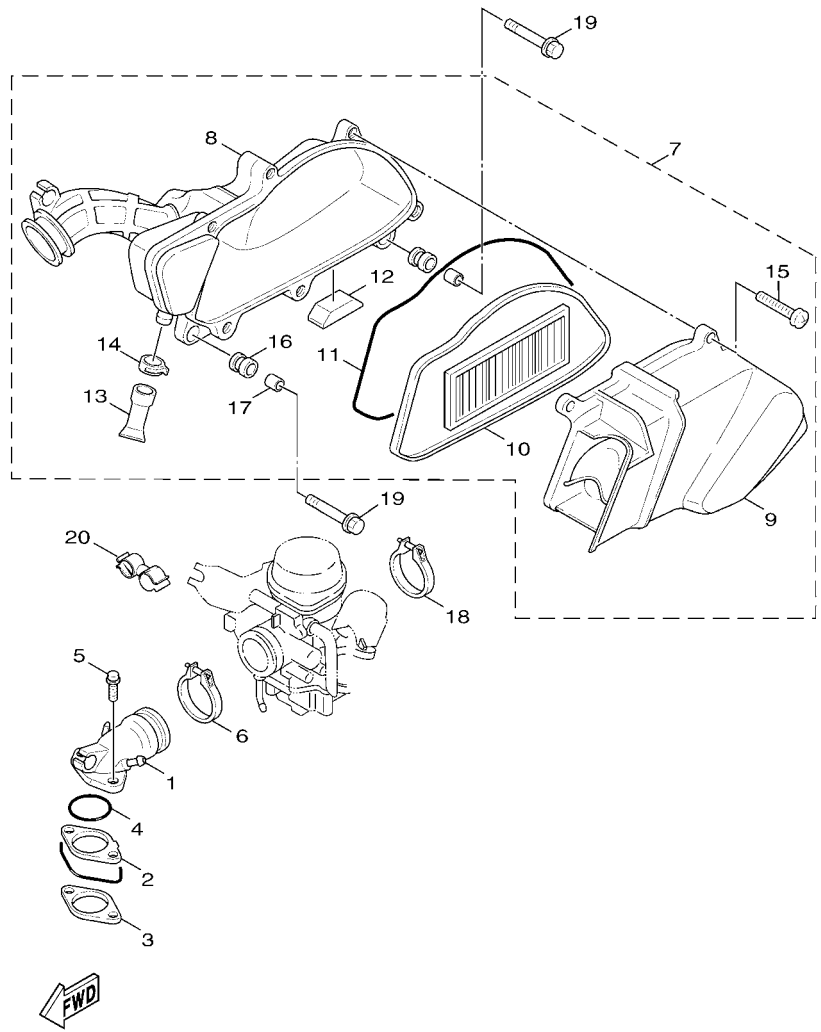

FIG. 5 OIL PUMP

REF. NO.	PART NO.	DESCRIPTION	010	020	030	040	050	REMARKS
1	5ML-E3300-00	OIL PUMP ASSY	1	1	1	1	1	
2	93602-13832	.PIN, DOWEL	1	1	1	1	1	
3	90201-077F5	.WASHER, PLATE	1	1	1	1	1	
4	99001-05600	.CIRCLIP	1	1	1	1	1	
5	5ML-E3325-00	.GEAR, PUMP DRIVEN	1	1	1	1	1	
6	5ML-E3475-00	GASKET	1	1	1	1	1	
7	98507-05020	SCREW, PAN HEAD	2	2	2	2	2	
8	5ML-E5351-00	PLUG, DRAIN	1	1	1	1	1	
9	5ML-E3411-00	STRAINER, OIL	1	1	1	1	1	
10	90501-16004	SPRING, COMPRESSION	1	1	1	1	1	
11	93210-29800	O-RING	1	1	1	1	1	



5TY1414-2050



5TY1414-2064

FIG. 6 INTAKE

REF. NO.	PART NO.	DESCRIPTION	010	020	030	040	050	REMARKS
1	5ML-E3585-10	MANIFOLD	1	1	1	1	1	
2	5ML-E3595-00	JOINT	1	1	1	1	1	
3	5ML-E3556-00	GASKET, MANIFOLD	1	1	1	1	1	
4	93210-27800	O-RING	1	1	1	1	1	
5	90109-06802	BOLT	2	2	2	2	2	
6	5ML-E3474-00	BAND	1	1	1	1	1	
7	5TY-E4410-10	AIR CLEANER ASSY.	1	1	1	1	1	
8	5TY-E4408-10	.AIR FILTER CASE COMP.	1	1	1	1	1	
9	5TY-W1442-10	.CAP, CLEANER CASE 1	1	1	1	1	1	
10	5TY-E4451-10	.ELEMENT, AIR CLEANER	1	1	1	1	1	
11	5TY-E4476-10	.SEAL	2	2	2	2	2	
12	5TY-E442G-10	.DAMPER 3	1	1	1	1	1	
13	5TY-E443E-10	.PIPE, DRAIN	2	2	2	2	2	
14	90467-13813	.CLIP	2	2	2	2	2	
15	5TY-E4429-10	.SCREW	6	6	6	6	6	
16	5TY-E4435-10	.GROMMET	2	2	2	2	2	
17	5TY-E4449-10	.COLLAR	2	2	2	2	2	
18	5ML-E3575-00	BAND	1	1	1	1	1	
19	95807-06030	BOLT, FLANGE	2	2	2	2	2	
20	90464-23811	CLAMP	1	1	1	1	1	

FIG. 7 CARBURETOR

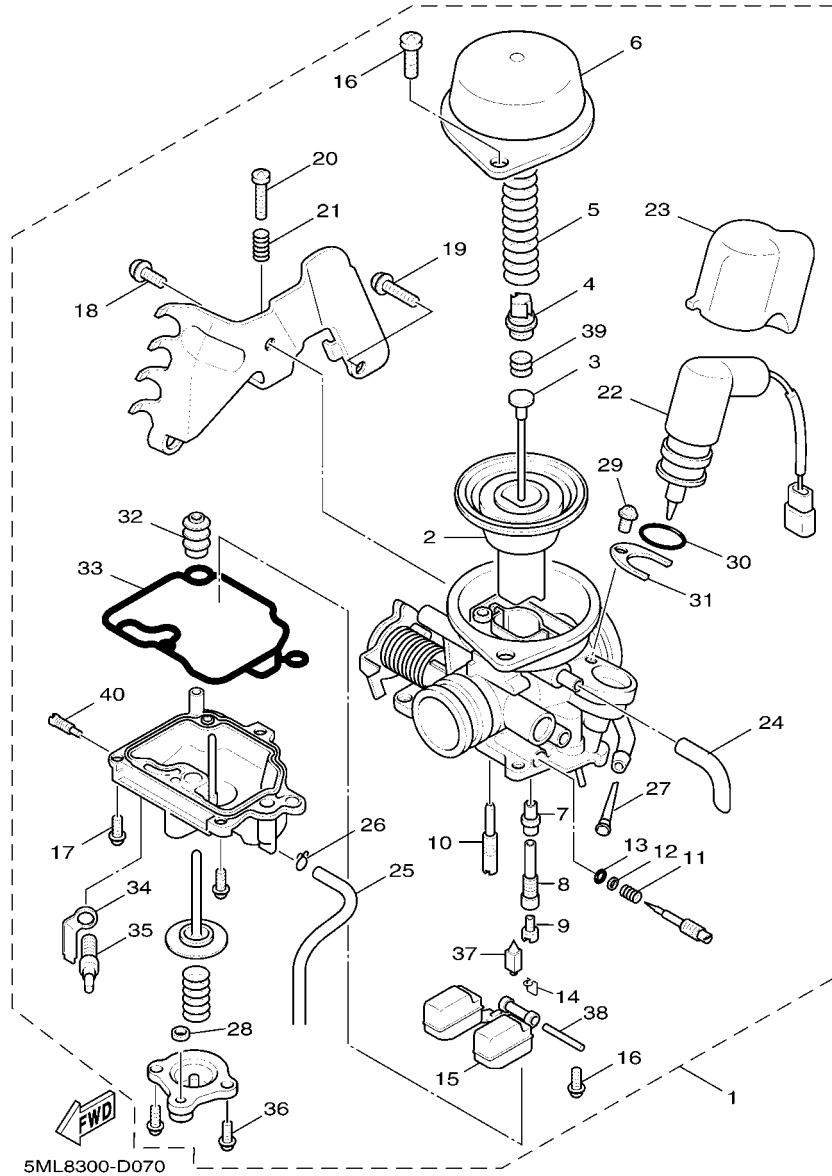

5ML8300-D070

REF. NO.	PART NO.	DESCRIPTION	010	020	030	040	050	REMARKS
1	5ML-E4901-10	CARBURETOR ASSY 1	1	1	1	1	1	
2	5TY-E4940-00	.DIAPHRAGM ASSY	1	1	1	1	1	
3	5ML-E4916-00	.NEEDLE	1	1	1	1	1	
4	5TY-E4936-00	.SEAT, SPRING	1	1	1	1	1	
5	5TY-E4933-00	.SPRING, DIAPHRAGM	1	1	1	1	1	
6	5TY-E4958-00	.COVER, DIAPHRAGM	1	1	1	1	1	
7	5TY-E4947-00	.JET, NEEDLE	1	1	1	1	1	
8	5ML-E414G-00	.PIPE, MAIN BREED	1	1	1	1	1	
9	5TY-E4943-28	.JET, MAIN (#105)	1	1	1	1	1	
10	5ML-E4948-01	.JET (#35)	1	1	1	1	1	
11	4JH-14160-00	.COIL, SPRING	1	1	1	1	1	
12	3TJ-14952-40	.WASHER	1	1	1	1	1	
13	3TJ-14562-40	.O-RING	1	1	1	1	1	
14	663-14159-00	.CLIP	1	1	1	1	1	
15	5TY-E4985-00	.FLOAT	1	1	1	1	1	
16	688-14592-00	.SCREW	3	3	3	3	3	
17	98502-04012	.SCREW, PAN HEAD	3	3	3	3	3	
18	5TY-E4245-00	.SCREW, GUIDE	1	1	1	1	1	
19	5TY-E4245-10	.SCREW, GUIDE	1	1	1	1	1	
20	5TY-E4922-00	.SCREW, THROTTLE	1	1	1	1	1	
21	5JG-14531-00	.SPRING, ADJUST SCREW	1	1	1	1	1	
22	5UA-E4370-10	.PLUNGER STARTER ASSY	1	1	1	1	1	
23	5TY-E4967-00	.COVER	1	1	1	1	1	
24	5TY-E4197-00	.PIPE	1	1	1	1	1	
25	5TY-E4196-00	.PIPE	1	1	1	1	1	
26	5BE-14937-00	.CLIP	1	1	1	1	1	
27	5TY-E4994-00	.NET, FILTER	1	1	1	1	1	

FIG. 8 EXHAUST

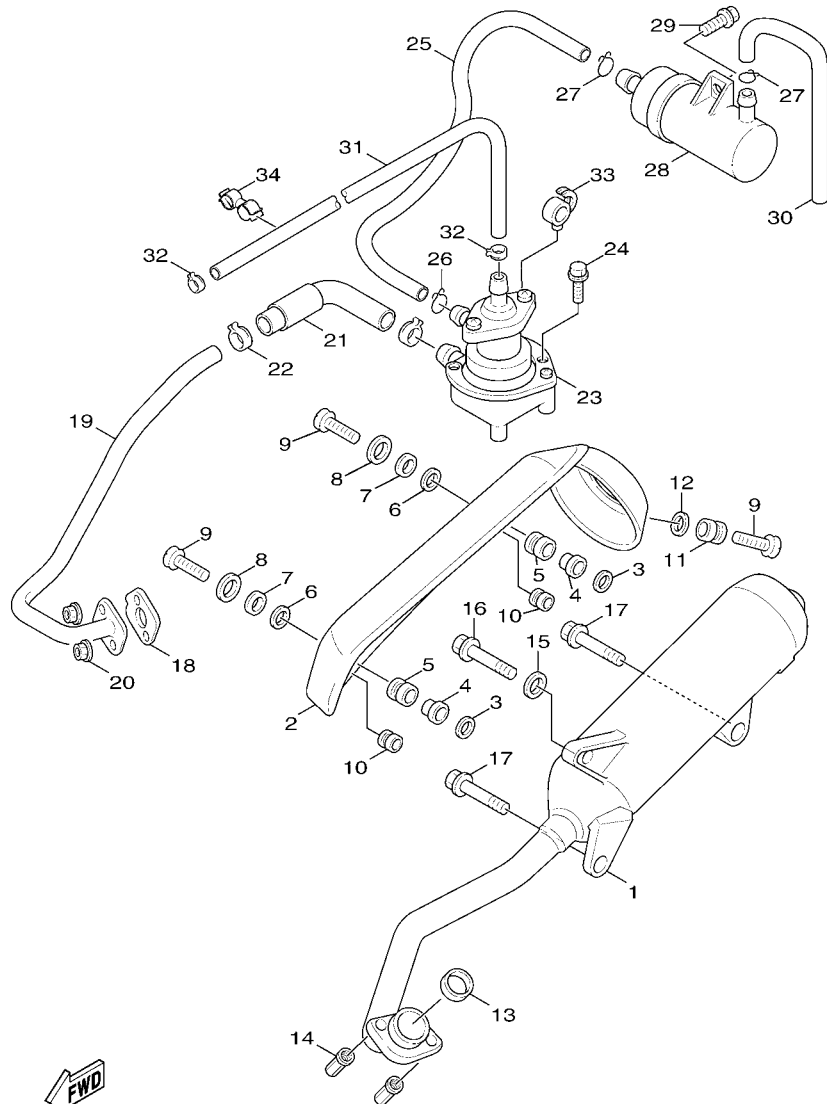

5TY1414-2081

REF. NO.	PART NO.	DESCRIPTION	010	020	030	040	050	REMARKS
1	5ML-E4610-00-98	EXHAUST PIPE ASSY 1	1	1	1	1	1	LGB
2	5ML-E4708-00	PROTECTOR ASSY	1	1	1	1	1	
3	4CW-E4766-00	WASHER, PROTECTOR	2	2	2	2	2	
4	5JS-E4779-00	COLLAR	2	2	2	2	2	
5	5JS-E4445-00	GROMMET	2	2	2	2	2	
6	5JS-E4759-00	WASHER	2	2	2	2	2	
7	5JS-E4617-00	WASHER	2	2	2	2	2	
8	90201-06055	WASHER, PLATE	2	2	2	2	2	
9	90111-06801	BOLT, HEX. SOCKET BUTTON	3	3	3	3	3	
10	90480-10332	GROMMET	2	2	2	2	2	
11	90480-14810	GROMMET	1	1	1	1	1	
12	90387-061N6	COLLAR	1	1	1	1	1	
13	4DH-14613-00	GASKET, EXHAUST PIPE	1	1	1	1	1	
14	90179-08804	NUT	2	2	2	2	2	
15	90201-101J1	WASHER, PLATE	1	1	1	1	1	
16	95817-10035	BOLT, FLANGE	1	1	1	1	1	
17	90105-08835	BOLT, FLANGE	2	2	2	2	2	
18	5ML-E4815-00	GASKET	1	1	1	1	1	
19	5ML-E4871-00	PIPE 1	1	1	1	1	1	
20	95707-06500	NUT, FLANGE	2	2	2	2	2	
21	5ML-E4883-00	HOSE, BEND 3	1	1	1	1	1	
22	90468-08812	CLIP	2	2	2	2	2	
23	5ML-E4803-10	AIR INDUCTION SYSTEM ASSY	1	1	1	1	1	
24	97007-06014	BOLT	2	2	2	2	2	
25	5ML-E4884-10	HOSE, BEND 4	1	1	1	1	1	
26	90467-16829	CLIP	1	1	1	1	1	
27	90467-18830	CLIP	2	2	2	2	2	

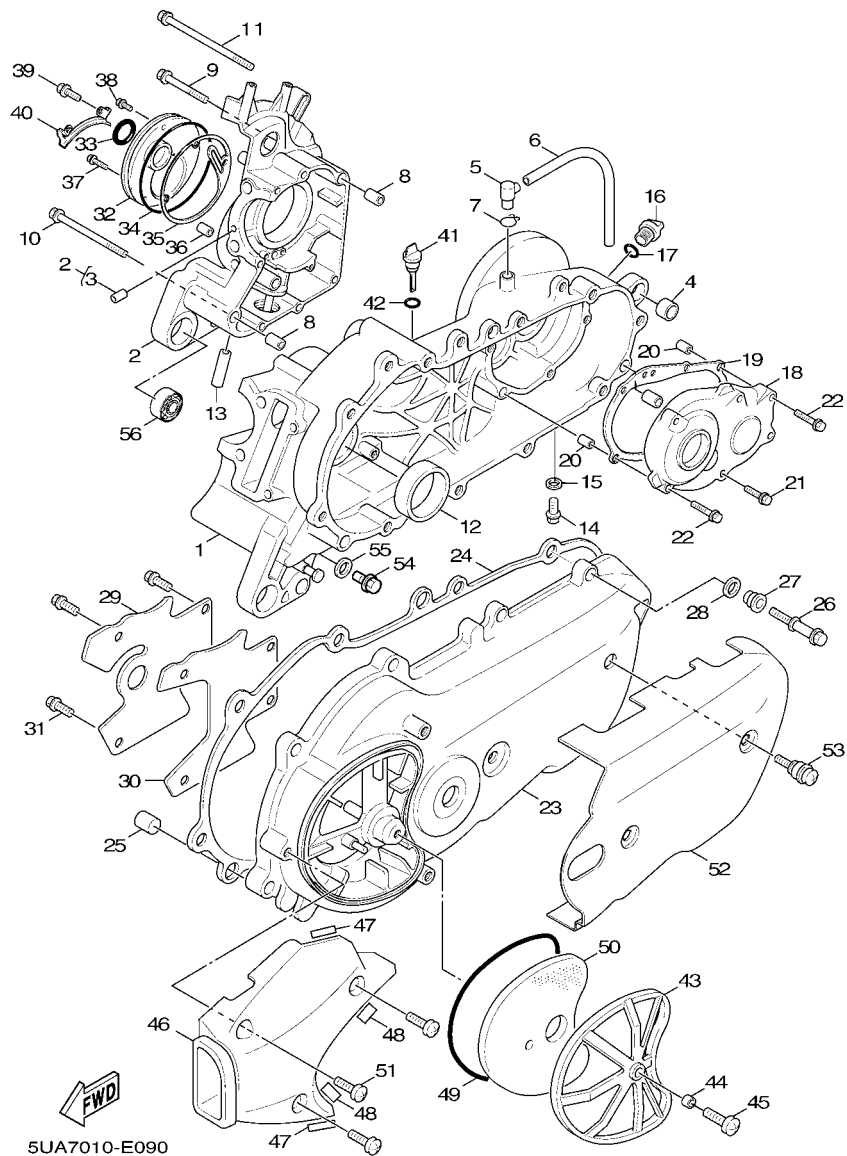

5UA7010-E090

FIG. 9 CRANKCASE

REF. NO.	PART NO.	DESCRIPTION	010	020	030	040	050	REMARKS
1	5ML-E5111-00	CRANKCASE 1	1	1	1	1	1	
2	5ML-W1512-01	CRANKCASE 2	1	1	1	1	1	
3	5ML-E5138-00	.NOZZLE 1	1	1	1	1	1	
4	4X6-F2216-00	BUSH, REAR SHOCK ABSORBER	1	1	1	1	1	
5	5CA-E5371-00	BREATHER	1	1	1	1	1	
6	90446-13803	HOSE	1	1	1	1	1	
7	90467-12052	CLIP	1	1	1	1	1	
8	91810-14807	PIN, DOWEL	2	2	2	2	2	
9	90105-06808	BOLT, FLANGE	6	6	6	6	6	
10	90105-06810	BOLT, FLANGE	1	1	1	1	1	
11	90105-06817	BOLT, FLANGE	1	1	1	1	1	
12	93102-22843	OIL SEAL	1	1	1	1	1	
13	5ML-E3416-00	PIPE, OIL 1	1	1	1	1	1	
14	95817-08016	BOLT, FLANGE	1	1	1	1	1	
15	90430-08816	GASKET	1	1	1	1	1	
16	4Y4-E5363-00	PLUG, OIL	1	1	1	1	1	
17	93210-14805	O-RING	1	1	1	1	1	
18	5ML-E5421-00	COVER, CRANKCASE 2	1	1	1	1	1	
19	5ML-E5461-00	GASKET, CRANKCASE COVER 2	1	1	1	1	1	
20	91810-14807	PIN, DOWEL	2	2	2	2	2	
21	90110-06813	BOLT, HEXAGON SOCKET HEAD	6	6	6	6	6	
22	90110-06815	BOLT, HEXAGON SOCKET HEAD	2	2	2	2	2	
23	5ML-E5411-00	COVER, CRANKCASE 1	1	1	1	1	1	
24	5ML-E5451-10	GASKET, CRANKCASE COVER 1	1	1	1	1	1	
25	93610-20800	PIN, DOWEL	2	2	2	2	2	
26	5ML-E5481-00	BOLT 1	10	10	10	10	10	
27	5ML-E5422-00	BUSH	10	10	10	10	10	

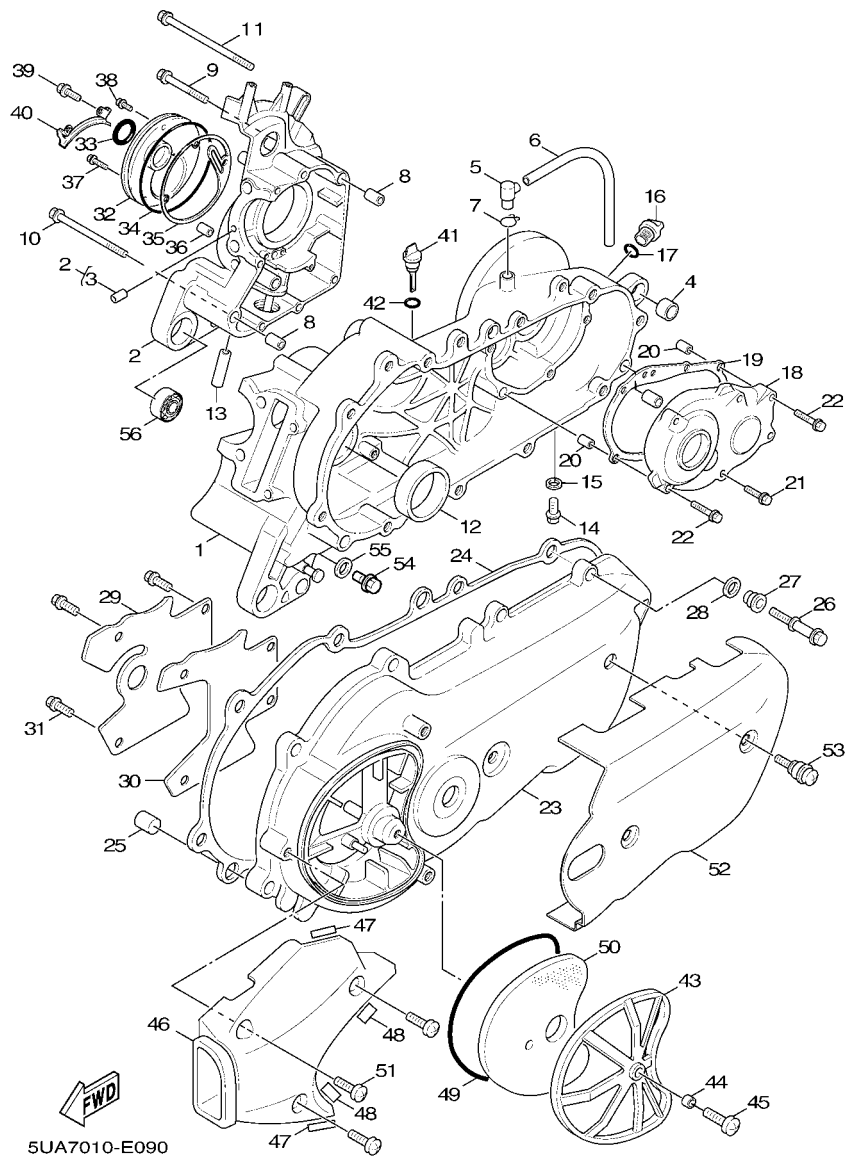

5UA7010-E090

FIG. 9 CRANKCASE

REF. NO.	PART NO.	DESCRIPTION	010	020	030	040	050	REMARKS
28	5ML-E5158-00	WASHER	10	10	10	10	10	
29	5ML-E5191-00	PLATE	1	1	1	1	1	
30	5ML-E5455-00	GASKET 1	1	1	1	1	1	
31	95027-06010	BOLT, FLANGE	4	4	4	4	4	
32	5ML-E5417-00	COVER, CAP	1	1	1	1	1	
33	93102-19293	OIL SEAL	1	1	1	1	1	
34	93211-07801	O-RING	1	1	1	1	1	
35	5ML-E5453-00	GASKET	1	1	1	1	1	
36	99480-05010	PIN	1	1	1	1	1	
37	90105-06809	BOLT, FLANGE	2	2	2	2	2	
38	90105-06807	BOLT, FLANGE	1	1	1	1	1	
39	90105-06806	BOLT, FLANGE	1	1	1	1	1	
40	5ML-E5113-00	PLATE	1	1	1	1	1	
41	5ML-E5362-00	PLUG, OIL LEVEL	1	1	1	1	1	
42	5ML-E3769-00	O-RING	1	1	1	1	1	
43	5ML-E5404-00	GUIDE, ELEMENT	1	1	1	1	1	
44	90387-06819	COLLAR	1	1	1	1	1	
45	98907-06016	SCREW, BIND	1	1	1	1	1	
46	5ML-X1547-00	DUCT, AIR	1	1	1	1	1	
47	5ML-E5338-00	.DAMPER, ENGINE MOUNT 5	1	1	1	1	1	
48	5ML-E5328-00	.SPACER, DAMPER	1	1	1	1	1	
49	5ML-E5472-00	SEAL, AIR DUCT	1	1	1	1	1	
50	5ML-E5407-00	ELEMENT 1	1	1	1	1	1	
51	98907-06020	SCREW, BIND	3	3	3	3	3	
52	5ML-X1543-00	COVER, CRANKCASE 3	1	1	1	1	1	
53	4DM-E5481-00	BOLT 1	2	2	2	2	2	
54	90340-12802	PLUG, STRAIGHT SCREW	1	1	1	1	1	

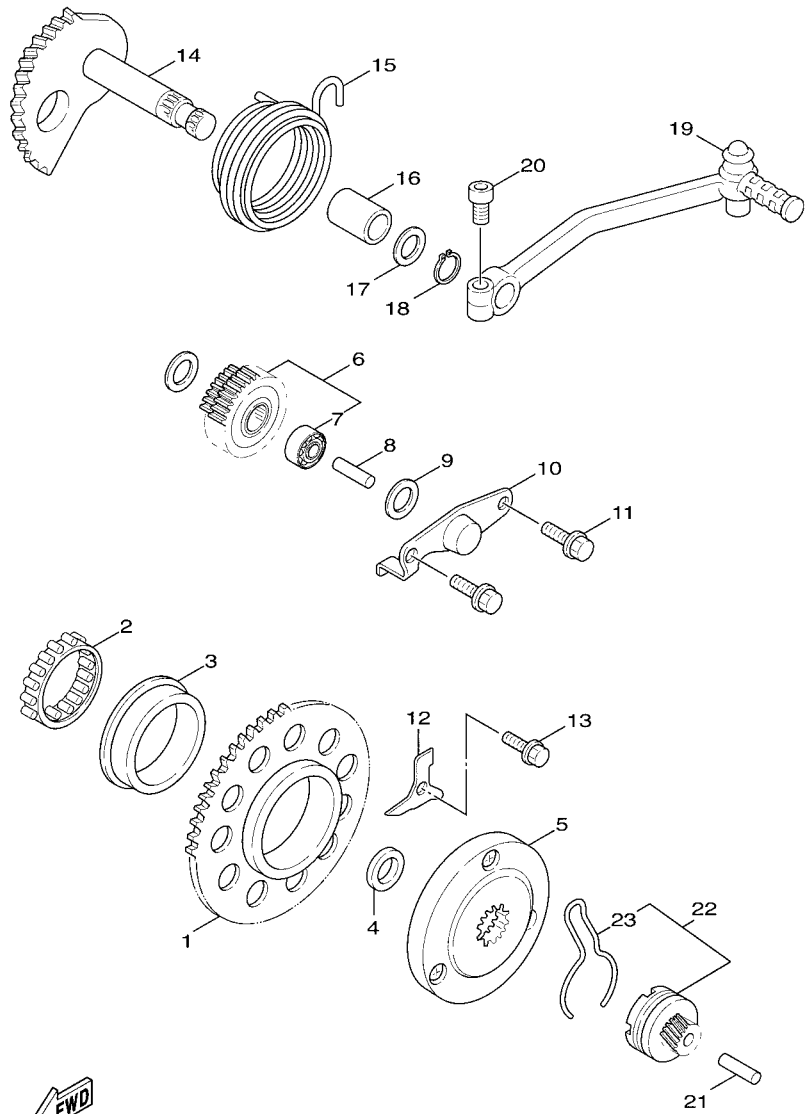

5TY1414-2100

FIG. 10 STARTER

REF. NO.	PART NO.	DESCRIPTION	010	020	030	040	050	REMARKS
1	5TY-E5524-00	WHEEL, STARTER	1	1	1	1	1	
2	93310-450X2	BEARING	1	1	1	1	1	
3	5LW-E5538-00	BOSS, GEAR 2	1	1	1	1	1	
4	90201-16802	WASHER, PLATE	1	1	1	1	1	
5	5TY-E5570-00	STARTER CLUTCH ASSY	1	1	1	1	1	
6	5ML-E5650-00	IDLE GEAR ASSY	1	1	1	1	1	
7	93315-110Y6	BEARING	1	1	1	1	1	
8	5CA-E5521-00	SHAFT 1	1	1	1	1	1	
9	90201-108A3	WASHER, PLATE	2	2	2	2	2	
10	5ML-E5532-00	PLATE, IDLE GEAR	1	1	1	1	1	
11	95027-06012	BOLT, FLANGE	2	2	2	2	2	
12	5TY-E5645-00	SHIM, KICK SHAFT	1	1	1	1	1	
13	95027-06012	BOLT, FLANGE	1	1	1	1	1	
14	5ML-E5601-00	KICK SHAFT ASSY	1	1	1	1	1	
15	90508-32609	SPRING, TORSION	1	1	1	1	1	
16	90380-15817	BUSH, SOLID	1	1	1	1	1	
17	90201-155G5	WASHER, PLATE	1	1	1	1	1	
18	99009-15400	CIRCLIP	1	1	1	1	1	
19	5ML-E5620-00	KICK CRANK ASSY	1	1	1	1	1	
20	91317-06030	BOLT	1	1	1	1	1	
21	5ML-E5659-00	SHAFT	1	1	1	1	1	
22	5ML-E5670-00	KICK PINION ASSY 2	1	1	1	1	1	
23	5ML-E5673-00	.CLIP	1	1	1	1	1	

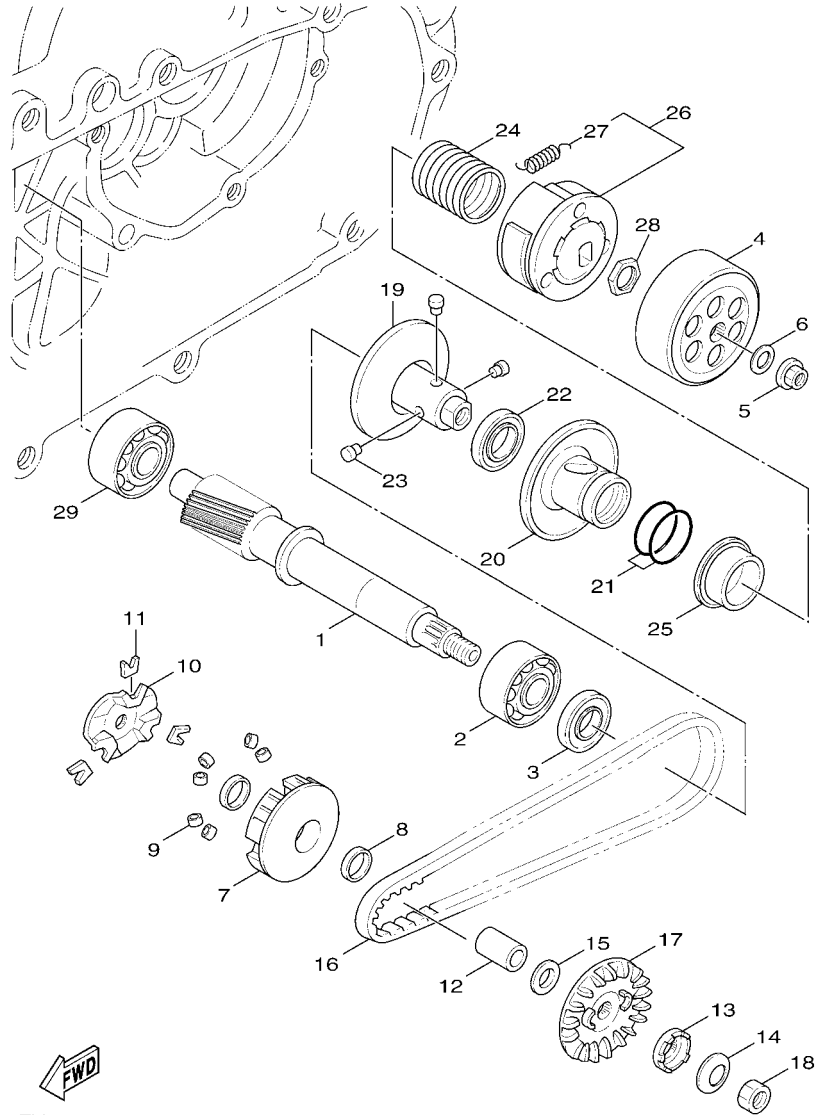

5TY1414-2111

FIG. 11 CLUTCH

REF. NO.	PART NO.	DESCRIPTION	010	020	030	040	050	REMARKS
1	5ML-E6111-01	GEAR, PRIMARY DRIVE	1	1	1	1	1	
2	93306-27210	BEARING	1	1	1	1	1	
3	93102-22800	OIL SEAL	1	1	1	1	1	
4	4CW-E6611-00	CLUTCH HOUSING COMP.	1	1	1	1	1	
5	90179-14427	NUT	1	1	1	1	1	
6	90201-144M8	WASHER, PLATE	1	1	1	1	1	
7	5ML-E7620-02	PRIMARY SLIDING SHEAVE COMP.	1	1	1	1	1	
8	93101-21170	OIL SEAL	2	2	2	2	2	
9	5ML-E7632-00	WEIGHT	6	6	6	6	6	
10	5ML-E7623-00	CAM	1	1	1	1	1	
11	5ML-E7653-01	SLIDER	3	3	3	3	3	
12	90387-16801	COLLAR	1	1	1	1	1	
13	5ML-E5657-00	CLUTCH, ONEWAY	1	1	1	1	1	
14	90208-12050	WASHER, CONICAL SPRING	1	1	1	1	1	
15	90201-16802	WASHER, PLATE	1	1	1	1	1	
16	5ML-E7641-00	V-BELT	1	1	1	1	1	
17	4HP-E7611-00	SHEAVE, PRIMARY FIXED	1	1	1	1	1	
18	95307-12700	NUT	1	1	1	1	1	
19	4CW-E7660-01	SECONDARY FIXED SHEAVE COMP.	1	1	1	1	1	
20	4KP-E7670-00	SECONDARY SLIDING SHEAVE	1	1	1	1	1	
21	93104-41801	OIL SEAL	2	2	2	2	2	
22	93210-43800	O-RING	2	2	2	2	2	
23	4CW-E7664-00	PIN, GUIDE	3	3	3	3	3	
24	90501-43801	SPRING, COMPRESSION	1	1	1	1	1	
25	5TY-E7644-01	SEAT, SPRING	1	1	1	1	1	
26	4TE-E6620-01	CLUTCH CARRIER ASSY	1	1	1	1	1	
27	4CW-E6626-00	.SPRING, CLUTCH WEIGHT 1	3	3	3	3	3	

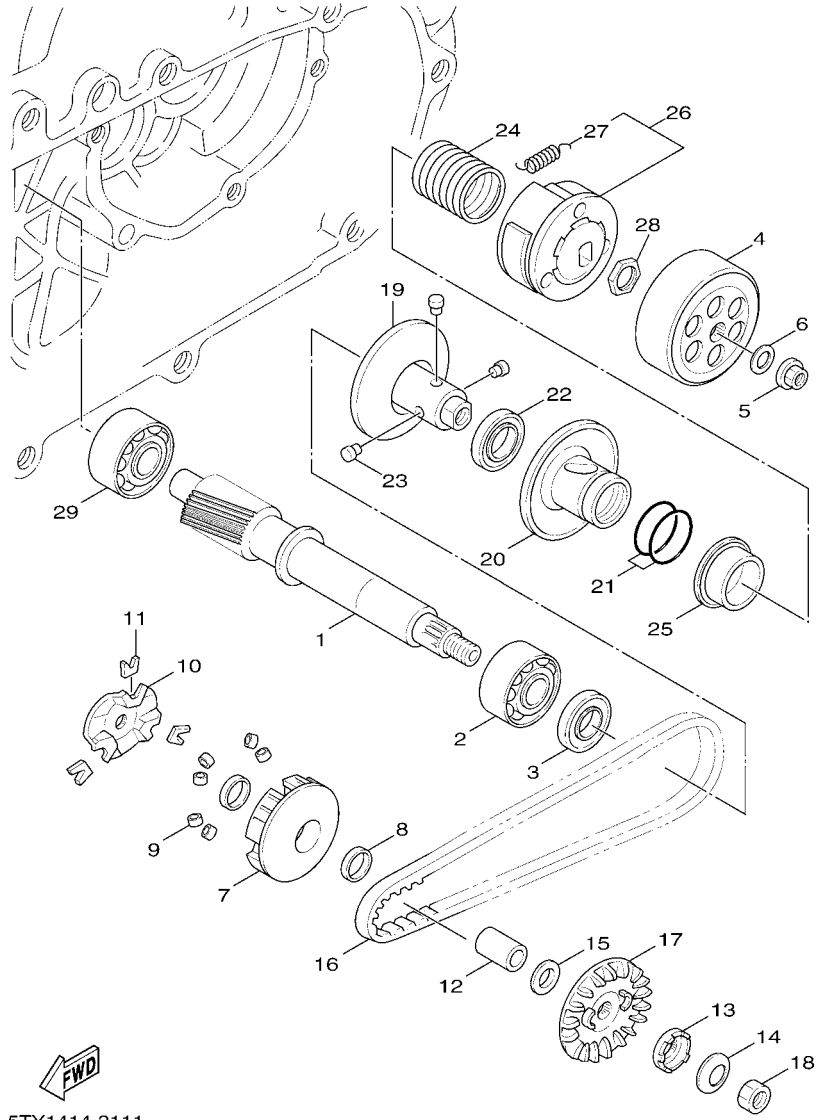

5TY1414-2111

FIG. 11 CLUTCH

REF. NO.	PART NO.	DESCRIPTION	010	020	030	040	050	REMARKS
28	90170-36279	NUT	1	1	1	1	1	
29	93306-20324	BEARING	1	1	1	1	1	

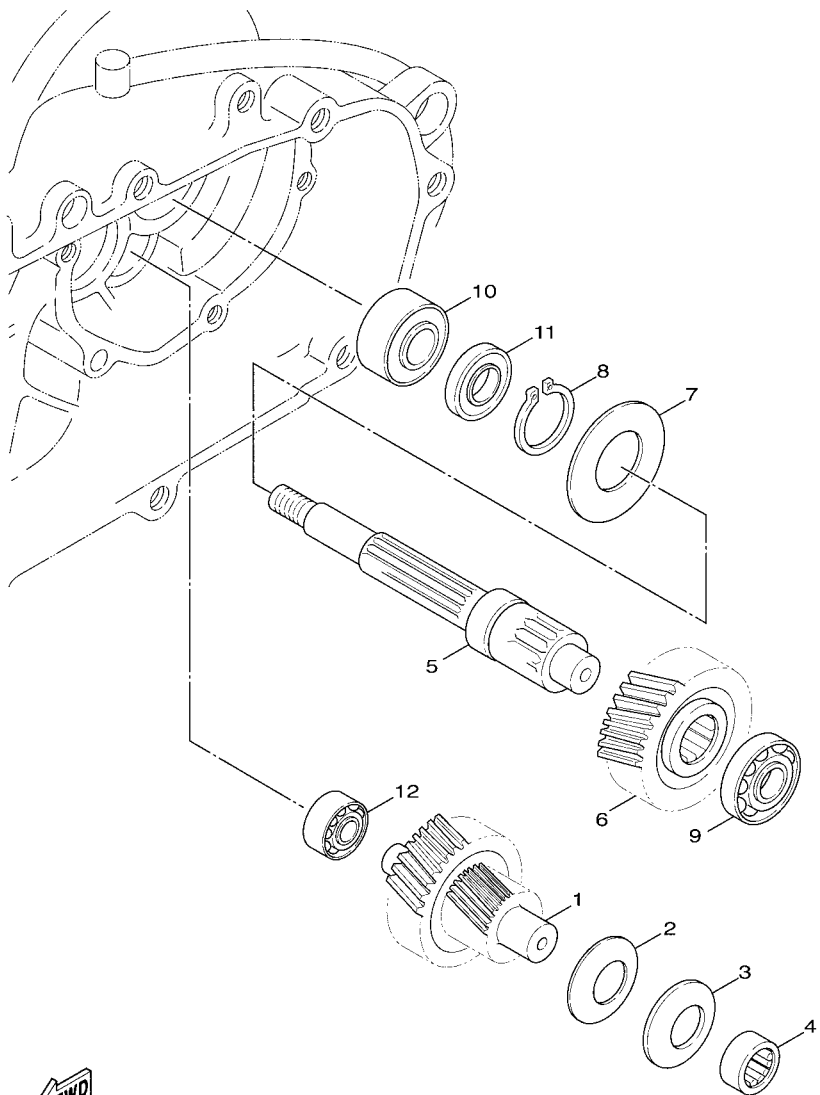

5TY1414-2120

FIG. 12 TRANSMISSION

REF. NO.	PART NO.	DESCRIPTION	010	020	030	040	050	REMARKS
1	5ML-E7410-01	MAIN AXLE COMP.	1	1	1	1	1	
2	90201-15803	WASHER, PLATE	1	1	1	1	1	
3	90208-15801	WASHER, CONICAL SPRING	1	1	1	1	1	
4	93311-315Y2	BEARING	1	1	1	1	1	
5	5ML-E7421-01	AXLE, DRIVE	1	1	1	1	1	
6	5ML-E7211-01	GEAR, 1ST WHEEL	1	1	1	1	1	
7	90208-25800	WASHER, CONICAL SPRING	1	1	1	1	1	
8	99009-25400	CIRCLIP	1	1	1	1	1	
9	93306-303Y8	BEARING	1	1	1	1	1	
10	93306-204YH	BEARING	1	1	1	1	1	
11	93102-26852	OIL SEAL	1	1	1	1	1	
12	93306-30113	BEARING	1	1	1	1	1	

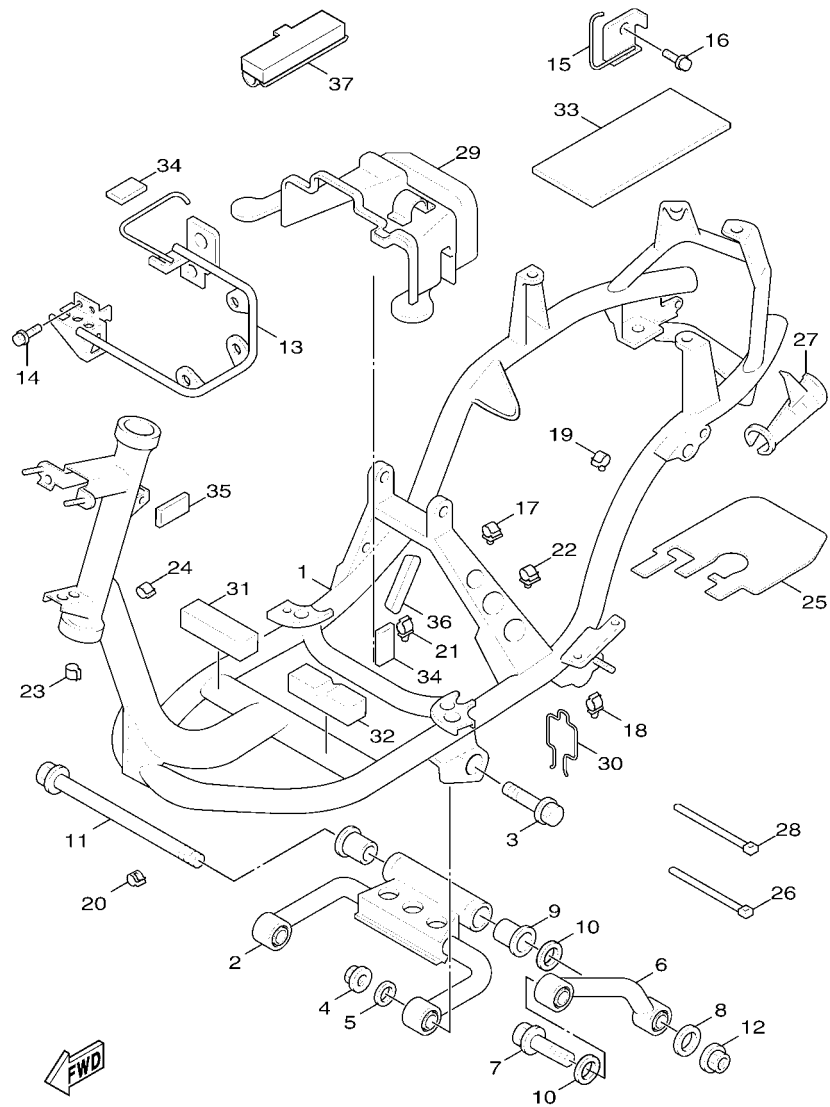

5MLA300-E130

FIG. 13 FRAME

REF. NO.	PART NO.	DESCRIPTION	010	020	030	040	050	REMARKS
1	5ML-F1110-01-33	FRAME COMP.	1	1	1	1	1	YB
2	5ML-F1420-01	ENGINE BRACKET COMP. 2	1	1	1	1	1	
3	3UH-F1481-00	BOLT, ENGINE MOUNTING 1	2	2	2	2	2	
4	90185-10801	NUT, SELF-LOCKING	2	2	2	2	2	
5	90201-105A2	WASHER, PLATE	2	2	2	2	2	
6	5ML-F1480-10	STAY, ENGINE	1	1	1	1	1	
7	95827-10045	BOLT, FLANGE	1	1	1	1	1	
8	90201-105A2	WASHER, PLATE	1	1	1	1	1	
9	5ML-F1544-01	COLLAR 1	2	2	2	2	2	
10	90202-15803	WASHER, PLATE	2	2	2	2	2	
11	5ML-F1481-00	BOLT, ENGINE MOUNTING 1	1	1	1	1	1	
12	90185-10801	NUT, SELF-LOCKING	1	1	1	1	1	
13	5UA-F1415-00	BRACKET, FRONT UPPER 1	1	1	1	1	1	
14	95807-06010	BOLT, FLANGE	3	3	3	3	3	
15	5ML-F1161-01	HOLDER, CABLE	1	1	1	1	1	
16	95807-06010	BOLT, FLANGE	1	1	1	1	1	
17	90464-07800	CLAMP	3	3	3	3	3	
18	90464-09801	CLAMP	2	2	2	2	2	
19	90464-11801	CLAMP	1	1	1	1	1	
20	90464-20803	CLAMP	2	2	2	2	2	
21	90464-10800	CLAMP	3	3	3	3	3	
22	90464-25803	CLAMP	1	1	1	1	1	
23	90464-18803	CLAMP	1	1	1	1	1	
24	90464-16803	CLAMP	2	2	2	2	2	
25	5ML-F162H-00	FLAP 3	1	1	1	1	1	
26	90465-13275	CLAMP	1	1	1	1	1	
27	5ML-F162J-00	FLAP 4	1	1	1	1	1	

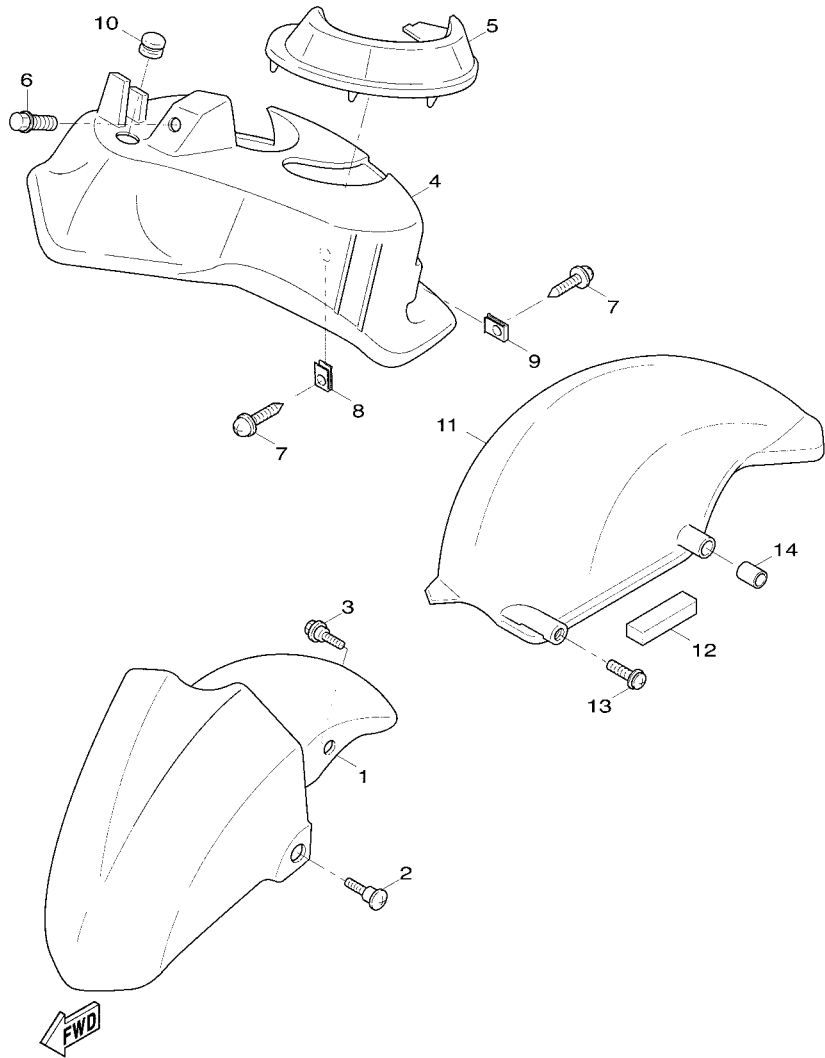

5TY1414-2142

FIG. 14 FRONT FENDER

REF. NO.	PART NO.	DESCRIPTION	010	020	030	040	050	REMARKS
1	5ML-F1511-10-7M	FENDER, FRONT	1	1	1	1	1	UR MDS
	5ML-F1511-10-P0	FENDER, FRONT	1	1	1	1	1	UR S1
	5ML-F1511-10-P2	FENDER, FRONT				1		UR WM1
	5ML-F1511-10-P6	FENDER, FRONT	1	1	1	1	1	UR LNBM8
2	90154-06807	SCREW, BINDING	2	2	2	2	2	
3	90109-06876	BOLT	2	2	2	2	2	
4	5ML-F1552-00	FENDER, INNER	1	1	1	1	1	
5	5ML-F151B-00	CAP	1	1	1	1	1	
6	90119-06821	BOLT, WITH WASHER	1	1	1	1	1	
7	97707-50016	SCREW, TAPPING	2	2	2	2	2	
8	90183-05807	NUT, SPRING	2	2	2	2	2	
9	90183-05807	NUT, SPRING	2	2	2	2	2	
10	5ML-F2417-00	PLUG	1	1	1	1	1	
11	5ML-X2161-00	FENDER, REAR	1	1	1	1	1	
12	5CA-F1639-00	.DAMPER 2	1	1	1	1	1	
13	98507-06014	SCREW, PAN HEAD	3	3	3	3	3	
14	90387-062M9	COLLAR	3	3	3	3	3	

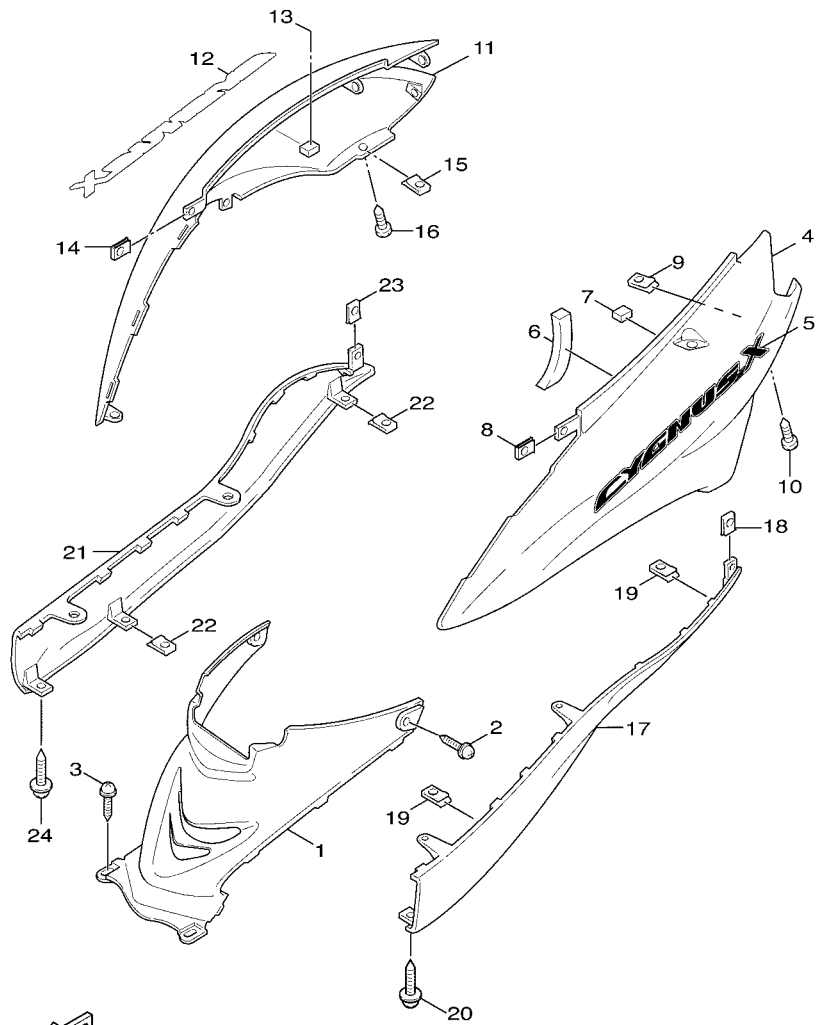

5UA1010-B150

FIG. 15 SIDE COVER

REF. NO.	PART NO.	DESCRIPTION	010	020	030	040	050	REMARKS
1	5ML-F1711-00	COVER, SIDE 1	1	1	1	1	1	
2	97707-50012	SCREW, TAPPING	2	2	2	2	2	
3	97707-50012	SCREW, TAPPING	2	2	2	2	2	
4	5ML-F1721-01-7M	COVER, SIDE 2	1	1	1	1	1	UR MDS
	5ML-F1721-01-P0	COVER, SIDE 2	1	1	1	1	1	UR S1
	5ML-F1721-01-P4	COVER, SIDE 2				1		UR WM1
	5ML-F1721-01-PB	COVER, SIDE 2	1	1	1	1	1	UR LNBM8
5	5ML-F173B-00	EMBLEM 3D	1	1	1	1	1	
6	5ML-F1746-00	DAMPER	1	1	1	1	1	
7	5ML-F1732-00	SEAL 1	2	2	2	2	2	
8	90183-05807	NUT, SPRING	1	1	1	1	1	
9	5ML-F176M-00	HOOK	1	1	1	1	1	
10	97707-50012	SCREW, TAPPING	1	1	1	1	1	
11	5ML-F1731-01-7M	COVER, SIDE 3	1	1	1	1	1	UR MDS
	5ML-F1731-01-P0	COVER, SIDE 3	1	1	1	1	1	UR S1
	5ML-F1731-01-P4	COVER, SIDE 3				1		UR WM1
	5ML-F1731-01-PB	COVER, SIDE 3	1	1	1	1	1	UR LNBM8
12	5ML-F174B-00	EMBLEM 3D	1	1	1	1	1	
13	5ML-F1732-00	SEAL 1	1	1	1	1	1	
14	90183-05807	NUT, SPRING	1	1	1	1	1	
15	5ML-F176M-00	HOOK	1	1	1	1	1	
16	97707-50012	SCREW, TAPPING	1	1	1	1	1	
17	5ML-F171L-00-7M	MOLE, SIDE COVER 1	1	1	1	1	1	UR MDS
	5ML-F171L-00-P0	MOLE, SIDE COVER 1	1	1	1	1	1	UR S1
	5ML-F171L-00-P4	MOLE, SIDE COVER 1				1		UR WM1
	5ML-F171L-00-P9	MOLE, SIDE COVER 1	1	1	1	1	1	UR LNBM8
18	90183-05807	NUT, SPRING	1	1	1	1	1	

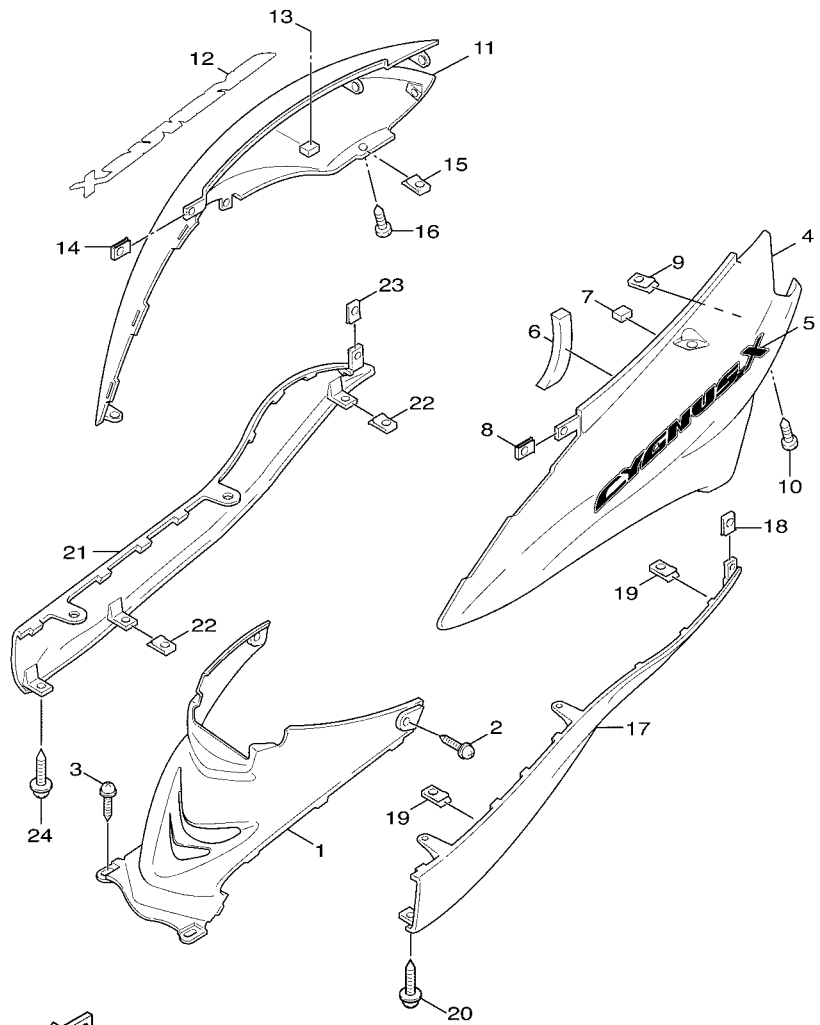

5UA1010-B150

FIG. 15 SIDE COVER

REF. NO.	PART NO.	DESCRIPTION	010	020	030	040	050	REMARKS
19	5ML-F176M-00	HOOK	2	2	2	2	2	
20	97707-50012	SCREW, TAPPING	5	5	5	5	5	
21	5ML-F171M-00-7M	MOLE, SIDE COVER 2	1	1	1	1	1	UR MDS
	5ML-F171M-00-P0	MOLE, SIDE COVER 2	1	1	1	1	1	UR S1
	5ML-F171M-00-P4	MOLE, SIDE COVER 2				1		UR WM1
	5ML-F171M-00-P9	MOLE, SIDE COVER 2	1	1	1	1	1	UR LNBM8
22	5ML-F176M-00	HOOK	2	2	2	2	2	
23	90183-05807	NUT, SPRING	1	1	1	1	1	
24	97707-50012	SCREW, TAPPING	5	5	5	5	5	

FIG. 16 REAR ARM & SUSPENSION

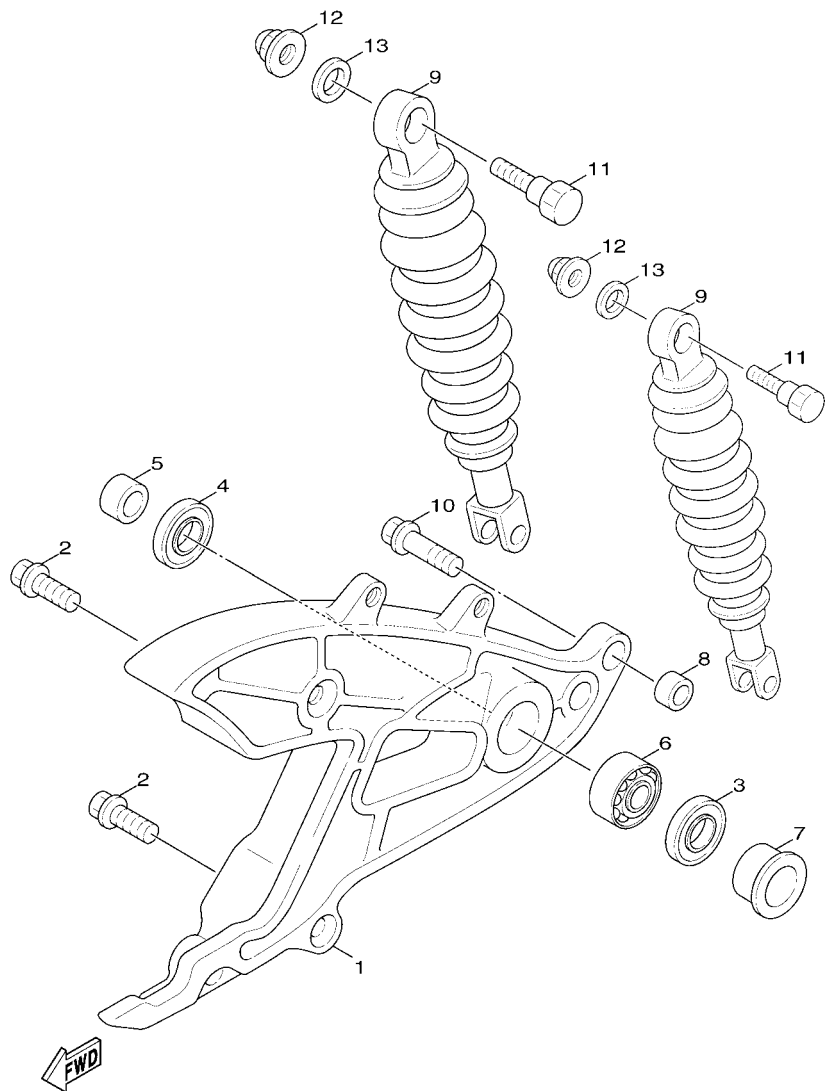

5TY1414-2162

REF. NO.	PART NO.	DESCRIPTION	010	020	030	040	050	REMARKS
1	5ML-F2171-00	ARM, REAR 1	1	1	1	1	1	
2	95827-08040	BOLT, FLANGE	2	2	2	2	2	
3	93109-28811	OIL SEAL	1	1	1	1	1	
4	93106-26823	OIL SEAL	1	1	1	1	1	
5	90387-15423	COLLAR	1	1	1	1	1	
6	93306-302X1	BEARING	1	1	1	1	1	
7	90387-153N8	COLLAR	1	1	1	1	1	
8	4X6-F2216-00	BUSH, REAR SHOCK ABSORBER	1	1	1	1	1	
9	5ML-F2210-10	SHOCK ABSORBER ASSY, REAR	2	2	2	2	2	
10	90105-08121	BOLT, FLANGE	2	2	2	2	2	
11	90101-10875	BOLT	2	2	2	2	2	
12	95307-10800	NUT	2	2	2	2	2	
13	90201-101J1	WASHER, PLATE	2	2	2	2	2	

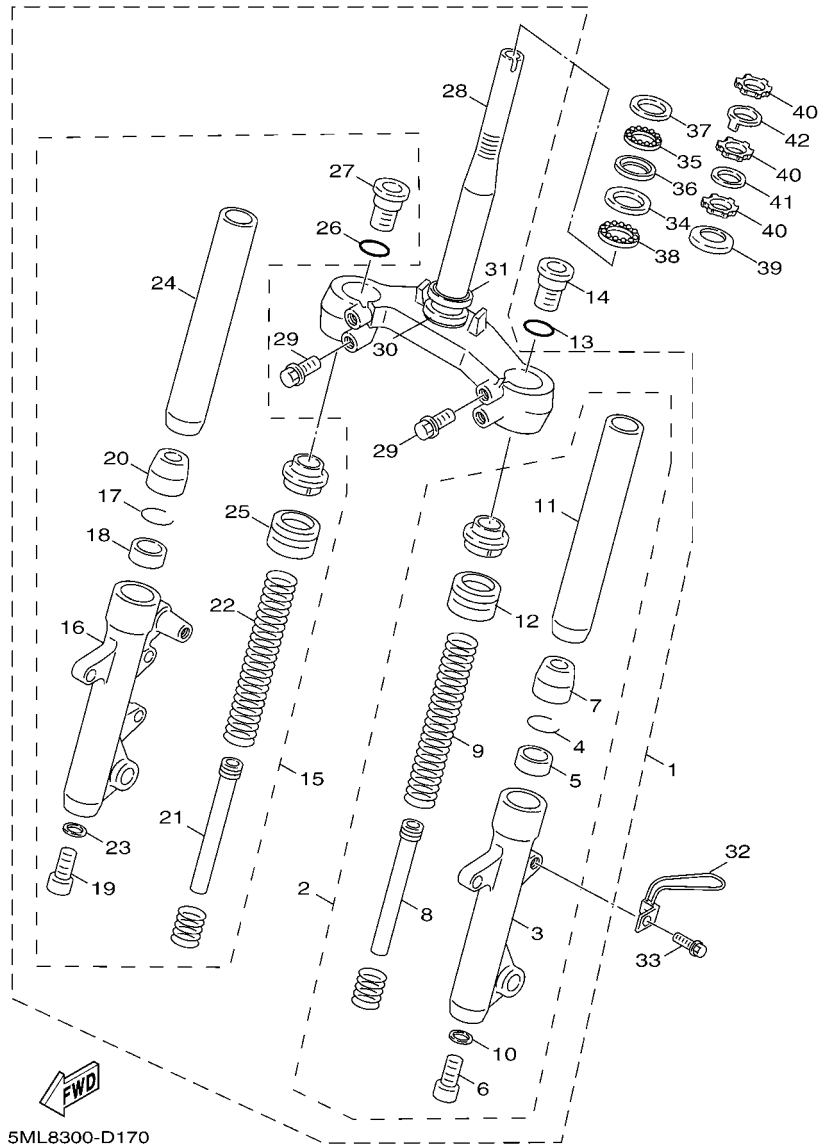

5ML8300-D170

FIG. 17 FRONT FORK

REF. NO.	PART NO.	DESCRIPTION	010	020	030	040	050	REMARKS
1	5ML-F3100-11-35	FRONT FORK ASSY	1	1	1	1	1	SL
2	5TY-F3102-10-35	..FRONT FORK ASSY (L.H)	1	1	1	1	1	
3	5ML-F3126-10-35	..TUBE, OUTER (LEFT)	1	1	1	1	1	
4	5ML-F3156-10	..CLIP, OIL SEAL	1	1	1	1	1	
5	5ML-F3145-10	..OIL SEAL	1	1	1	1	1	
6	3UH-F3181-00	..BOLT, HEXAGON SOCKET HEAD	1	1	1	1	1	
7	3UH-F3173-00	..SPINDLE, TAPER	1	1	1	1	1	
8	5ML-F3171-10	..PISTON, FRONT FORK	1	1	1	1	1	
9	5ML-F3141-10	..SPRING, FRONT FORK	1	1	1	1	1	
10	3UH-F3158-00	..GASKET	1	1	1	1	1	
11	5ML-F3110-10	..INNER TUBE COMP.1	1	1	1	1	1	
12	5ML-F331G-10	..COVER	1	1	1	1	1	
13	3UH-F3114-00	..GASKET	1	1	1	1	1	
14	5ML-F3356-10	..BOLT 2	1	1	1	1	1	
15	5ML-F3103-10-35	..FRONT FORK ASSY (R.H)	1	1	1	1	1	
16	5ML-F3136-10-35	..TUBE, OUTER (RIGHT)	1	1	1	1	1	
17	5ML-F3156-10	..CLIP, OIL SEAL	1	1	1	1	1	
18	5ML-F3145-10	..OIL SEAL	1	1	1	1	1	
19	3UH-F3181-00	..BOLT, HEXAGON SOCKET HEAD	1	1	1	1	1	
20	3UH-F3173-00	..SPINDLE, TAPER	1	1	1	1	1	
21	5ML-F3171-10	..PISTON, FRONT FORK	1	1	1	1	1	
22	5ML-F3141-10	..SPRING, FRONT FORK	1	1	1	1	1	
23	3UH-F3158-00	..GASKET	1	1	1	1	1	
24	5ML-F3110-10	..INNER TUBE COMP.1	1	1	1	1	1	
25	5ML-F331G-10	..COVER	1	1	1	1	1	
26	3UH-F3114-00	..GASKET	1	1	1	1	1	
27	5ML-F3356-10	..BOLT 2	1	1	1	1	1	

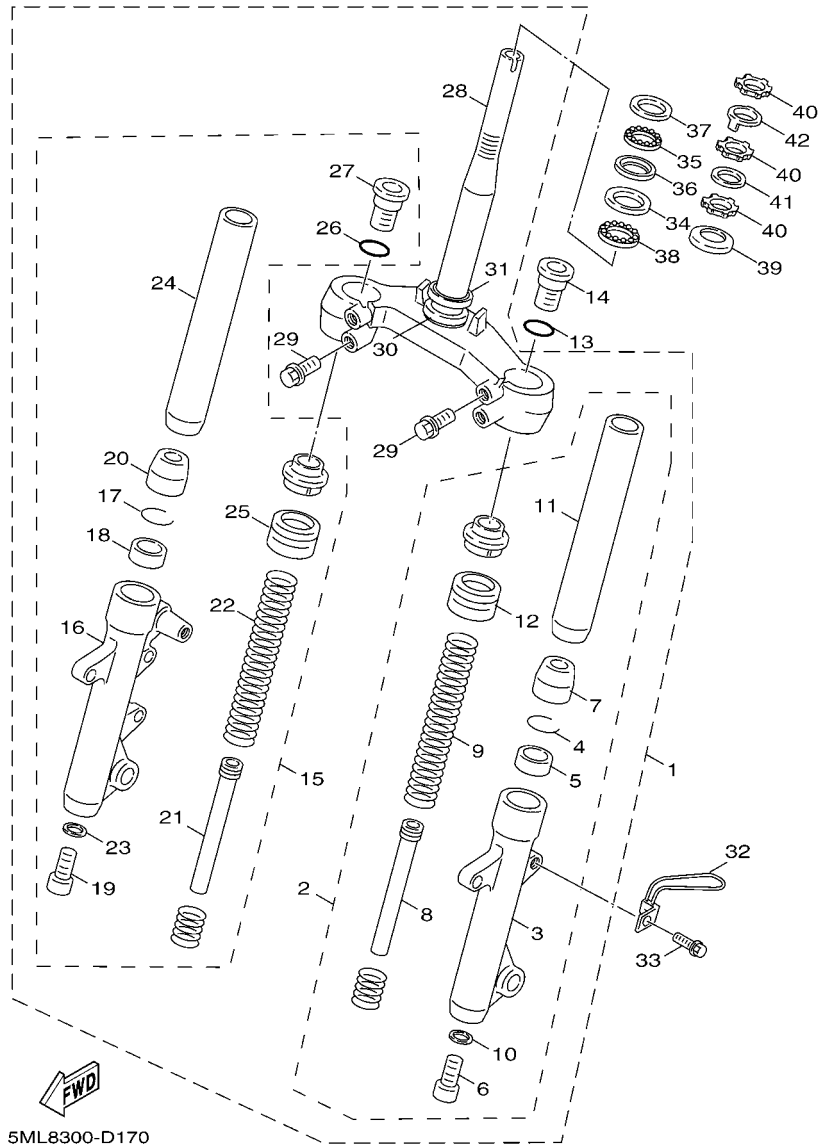
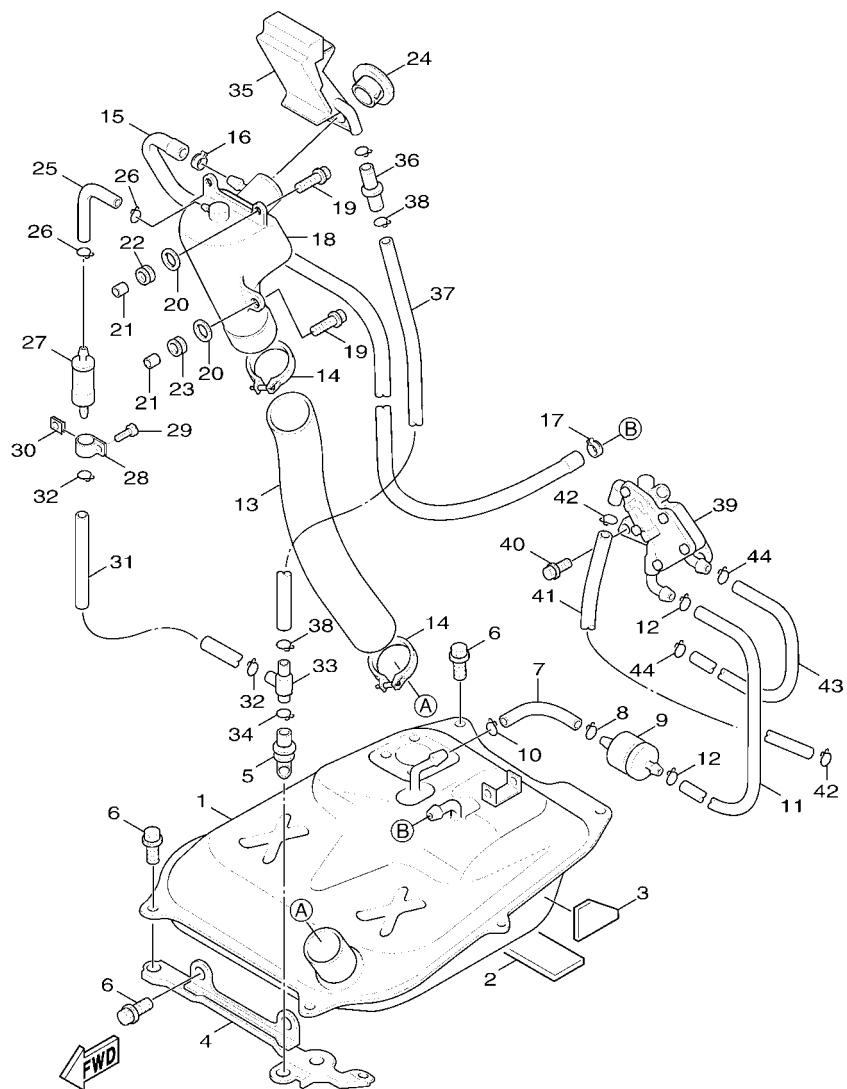

FIG. 17 FRONT FORK

REF. NO.	PART NO.	DESCRIPTION	010	020	030	040	050	REMARKS
28	5ML-F3340-10	.UNDER BRACKET COMP.	1	1	1	1	1	
29	5TY-F3346-00	.BOLT 1	4	4	4	4	4	
30	1MH-F3411-00	.RACE, BALL 1	1	1	1	1	1	
31	3KW-F3462-00	.SEAL, STEERING	1	1	1	1	1	
32	5ML-F3317-00	HOLDER, CABLE	1	1	1	1	1	
33	9580L-06020	BOLT, FLANGE	1	1	1	1	1	
34	156-23412-00	RACE, BALL 2	1	1	1	1	1	
35	156-2341E-00	RETAINER, BALL BEARING	1	1	1	1	1	
36	22F-23412-01	RACE, BALL 2	1	1	1	1	1	
37	22F-23411-01	RACE, BALL 1	1	1	1	1	1	
38	22F-2341E-00	RETAINER, BALL BEARING	1	1	1	1	1	
39	4TE-F3416-00	COVER, BALL RACE 2	1	1	1	1	1	
40	90179-25615	NUT	3	3	3	3	3	
41	90202-26142	WASHER, PLATE	1	1	1	1	1	
42	4VP-F3418-00	WASHER, SPECIAL	1	1	1	1	1	

FIG. 18 FUEL TANK



5UA6010-D180

REF. NO.	PART NO.	DESCRIPTION	010	020	030	040	050	REMARKS
1	5ML-F4110-00-33	FUEL TANK COMP.	1	1	1	1	1	YB
2	5ML-F4181-00	DAMPER, LOCATING 1	1	1	1	1	1	
3	5ML-F4183-00	DAMPER, LOCATING 3	1	1	1	1	1	
4	5ML-F4115-00	STAY, FUEL TANK 1	1	1	1	1	1	
5	5ML-F4339-00	GROMMET	1	1	1	1	1	
6	90119-06856	BOLT, WITH WASHER	6	6	6	6	6	
7	5ML-F4311-01	PIPE, FUEL 1	1	1	1	1	1	
8	90467-08003	CLIP	1	1	1	1	1	
9	5CA-F4560-00	FILTER ASSY	1	1	1	1	1	
10	90467-09006	CLIP	1	1	1	1	1	
11	5ML-F4312-01	PIPE 2	1	1	1	1	1	
12	90467-08003	CLIP	2	2	2	2	2	
13	5ML-F4316-00	PIPE 6	1	1	1	1	1	
14	90450-60001	HOSE CLAMP ASSY	2	2	2	2	2	
15	5ML-F4317-00	PIPE 7	1	1	1	1	1	
16	90468-08812	CLIP	1	1	1	1	1	
17	90467-20810	CLIP	1	1	1	1	1	
18	5ML-F4280-00	TANK, FUEL	1	1	1	1	1	
19	95827-06025	BOLT, FLANGE	3	3	3	3	3	
20	90201-06072	WASHER, PLATE	3	3	3	3	3	
21	90387-07598	COLLAR	3	3	3	3	3	
22	90480-18290	GROMMET	2	2	2	2	2	
23	90480-01326	GROMMET	1	1	1	1	1	
24	5ML-F4602-00	CAP ASSY	1	1	1	1	1	
25	5ML-F4313-00	PIPE 3	1	1	1	1	1	
26	90467-08003	CLIP	2	2	2	2	2	
27	5ML-F4180-00	ROLL OVER VALVE ASSY	1	1	1	1	1	

FIG. 18 FUEL TANK

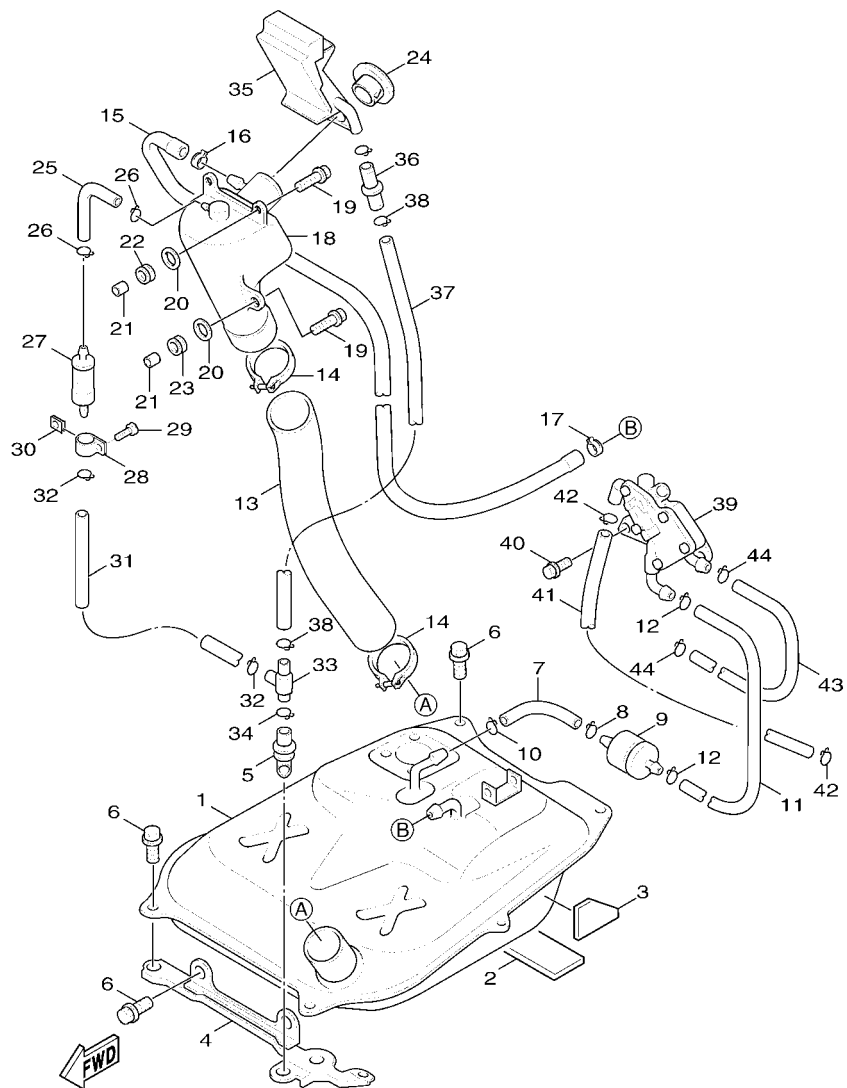

5UA6010-D180

REF. NO.	PART NO.	DESCRIPTION	010	020	030	040	050	REMARKS
28	90461-15801	CLAMP	1	1	1	1	1	
29	97707-50014	SCREW, TAPPING	1	1	1	1	1	
30	90183-05807	NUT, SPRING	1	1	1	1	1	
31	5ML-F4314-00	PIPE 4	1	1	1	1	1	
32	90467-09006	CLIP	2	2	2	2	2	
33	3UH-F4376-00	PIPE, JOINT 1	1	1	1	1	1	
34	90467-10041	CLIP	1	1	1	1	1	
35	5ML-F414A-00	COVER, FILLER	1	1	1	1	1	
36	5ML-F1753-01	BOSS, CONNECTOR	1	1	1	1	1	
37	5ML-F4318-00	PIPE, OVERFLOW	1	1	1	1	1	
38	90467-10041	CLIP	2	2	2	2	2	
39	5UA-E3910-01	FUEL PUMP ASSY	1	1	1	1	1	
40	95027-06010	BOLT, FLANGE	2	2	2	2	2	
41	5ML-E4294-00	HOSE	1	1	1	1	1	
42	90467-09006	CLIP	2	2	2	2	2	
43	5ML-E3929-00	PIPE, IMPULSE	1	1	1	1	1	
44	90467-10008	CLIP	2	2	2	2	2	

FIG. 19 SEAT

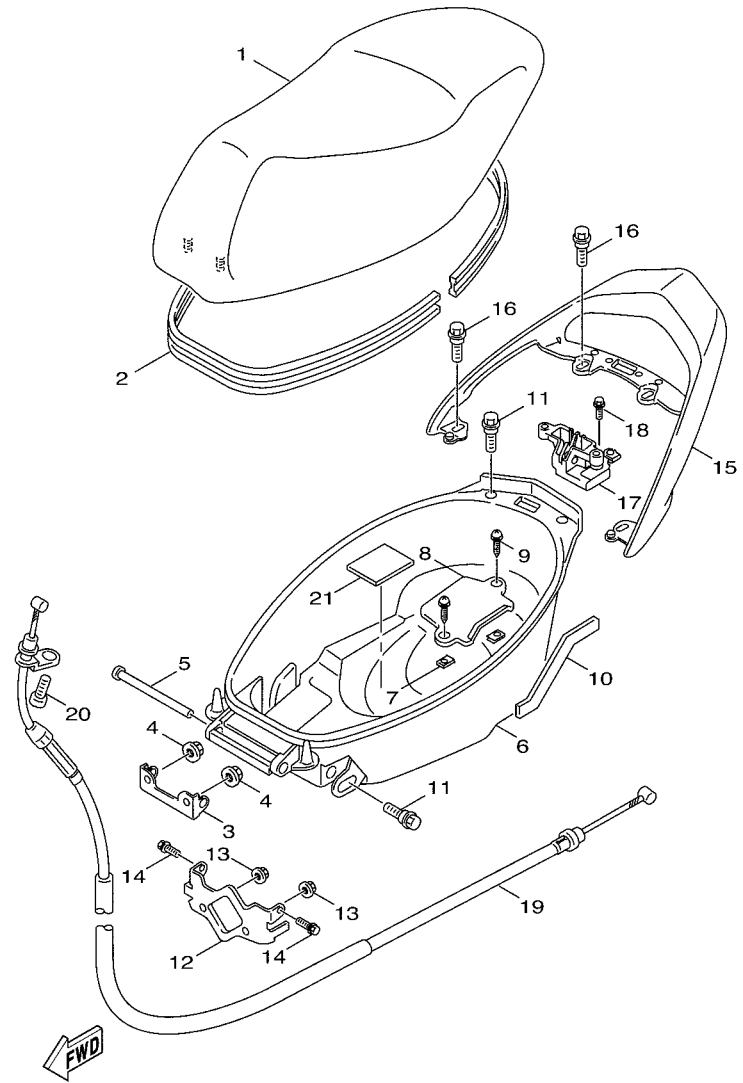

5ML1414-2190

REF. NO.	PART NO.	DESCRIPTION	010	020	030	040	050	REMARKS
1	5ML-F4730-00	DOUBLE SEAT ASSY	1	1	1	1	1	
2	5ML-F475M-01	.SEAL	1	1	1	1	1	
3	5UA-F4726-00	HINGE, SEAT	1	1	1	1	1	
4	95707-06500	NUT, FLANGE	2	2	2	2	2	
5	90241-10015	PIN	1	1	1	1	1	
6	5ML-F473R-01	BOX 1	1	1	1	1	1	
7	90183-05807	NUT, SPRING	2	2	2	2	2	
8	5ML-F473T-00	LID 1	1	1	1	1	1	
9	97707-50012	SCREW, TAPPING	2	2	2	2	2	
10	5ML-F4723-00	DAMPER, SEAT	1	1	1	1	1	
11	90109-063F1	BOLT	4	4	4	4	4	
12	5ML-F4491-00	BRACKET, FUEL PUMP	1	1	1	1	1	
13	2GF-F1535-00	NUT 1	2	2	2	2	2	
14	95807-06012	BOLT, FLANGE	2	2	2	2	2	
15	5ML-F4812-00-7M	HANDLE	1	1	1	1	1	UR MDS
	5ML-F4812-00-P0	HANDLE	1	1	1	1	1	UR S1
	5ML-F4812-00-P4	HANDLE				1		UR WM1
	5ML-F4812-00-PA	HANDLE	1	1	1	1	1	UR LNBM8
16	90119-08821	BOLT, WITH WASHER	4	4	4	4	4	
17	4UE-F4780-02	SEAT LOCK ASSY	1	1	1	1	1	
18	95807-06016	BOLT, FLANGE	2	2	2	2	2	
19	5ML-F478E-10	CABLE, SEAT LOCK	1	1	1	1	1	
20	98507-05010	SCREW, PAN HEAD	1	1	1	1	1	
21	5ML-F139X-00	DAMPER	1	1	1	1	1	

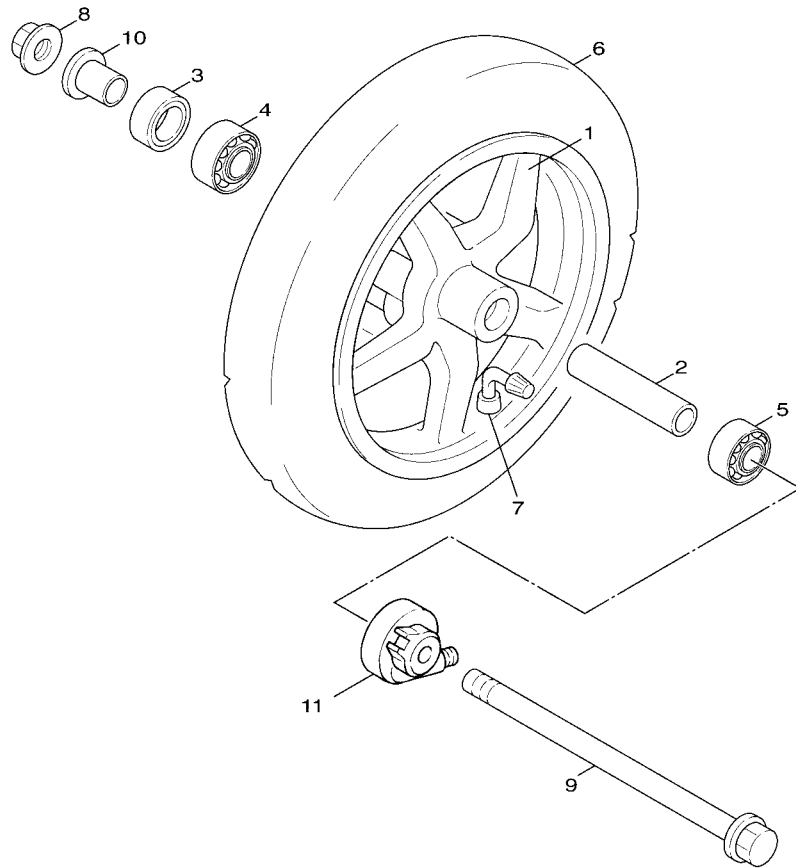

5UA1010-B200

FIG. 20 FRONT WHEEL

REF. NO.	PART NO.	DESCRIPTION	010	020	030	040	050	REMARKS
1	5ML-F5168-00-35	CAST WHEEL, FRONT	1	1	1	1	1	SL
2	5ML-F5183-00	COLLAR, WHEEL	1	1	1	1	1	
3	93102-17853	OIL SEAL	1	1	1	1	1	
4	93306-201Y7	BEARING	1	1	1	1	1	
5	93306-301YA	BEARING	1	1	1	1	1	
6	94111-12802	TIRE (110/70-12 C922N 47L)	1	1	1	1	1	
7	93900-00802	VALVE, RIM	1	1	1	1	1	
8	95607-12200	NUT, SELF-LOCKING	1	1	1	1	1	
9	5ML-F5181-00	AXLE, WHEEL	1	1	1	1	1	
10	90387-125J1	COLLAR	1	1	1	1	1	
11	5UA-F5190-00	GEAR UNIT ASSY	1	1	1	1	1	

FIG. 22 REAR WHEEL

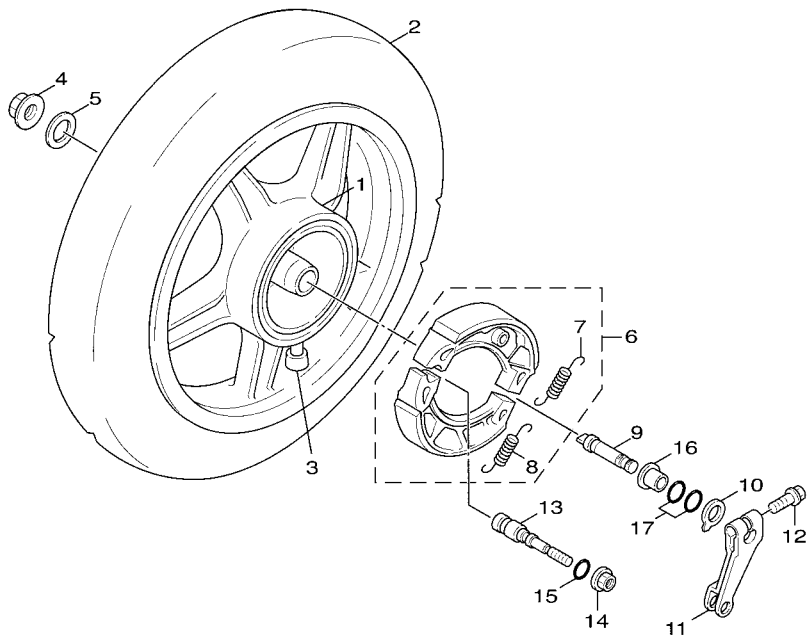

REF. NO.	PART NO.	DESCRIPTION	010	020	030	040	050	REMARKS
1	5ML-F5338-00-35	CAST WHEEL, REAR	1	1	1	1	1	SL
2	94112-12801	TIRE	1	1	1	1	1	
3	93900-00802	VALVE, RIM	1	1	1	1	1	
4	90185-14124	NUT, SELF-LOCKING	1	1	1	1	1	
5	90201-20276	WASHER, PLATE (T=1.0)	1	1	1	1	1	
6	5ML-X2533-00	BRAKE SHOE SET	1	1	1	1	1	
7	90506-13800	.SPRING, TENSION	1	1	1	1	1	
8	90506-16802	.SPRING, TENSION	1	1	1	1	1	
9	5ML-F5351-00	CAMSHAFT	1	1	1	1	1	
10	4VP-F533A-00	PLATE, INDICATOR	1	1	1	1	1	
11	5CA-F5355-00	LEVER, CAMSHAFT	1	1	1	1	1	
12	90101-06291	BOLT	1	1	1	1	1	
13	5ML-F5326-00	PIN, PIVOT	1	1	1	1	1	
14	95707-10500	NUT, FLANGE	1	1	1	1	1	
15	93210-09859	O-RING	1	1	1	1	1	
16	5ML-F5377-00	COLLAR, WHEEL	1	1	1	1	1	
17	93210-14802	O-RING	2	2	2	2	2	



5TY1414-2220

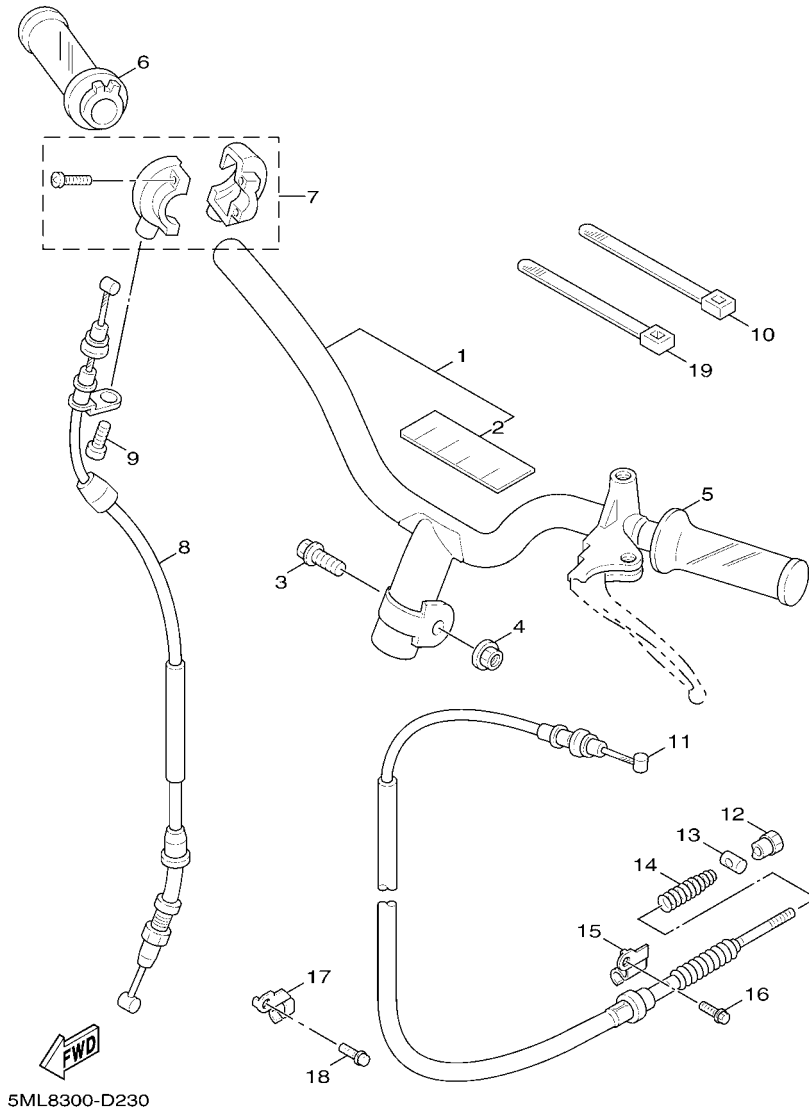
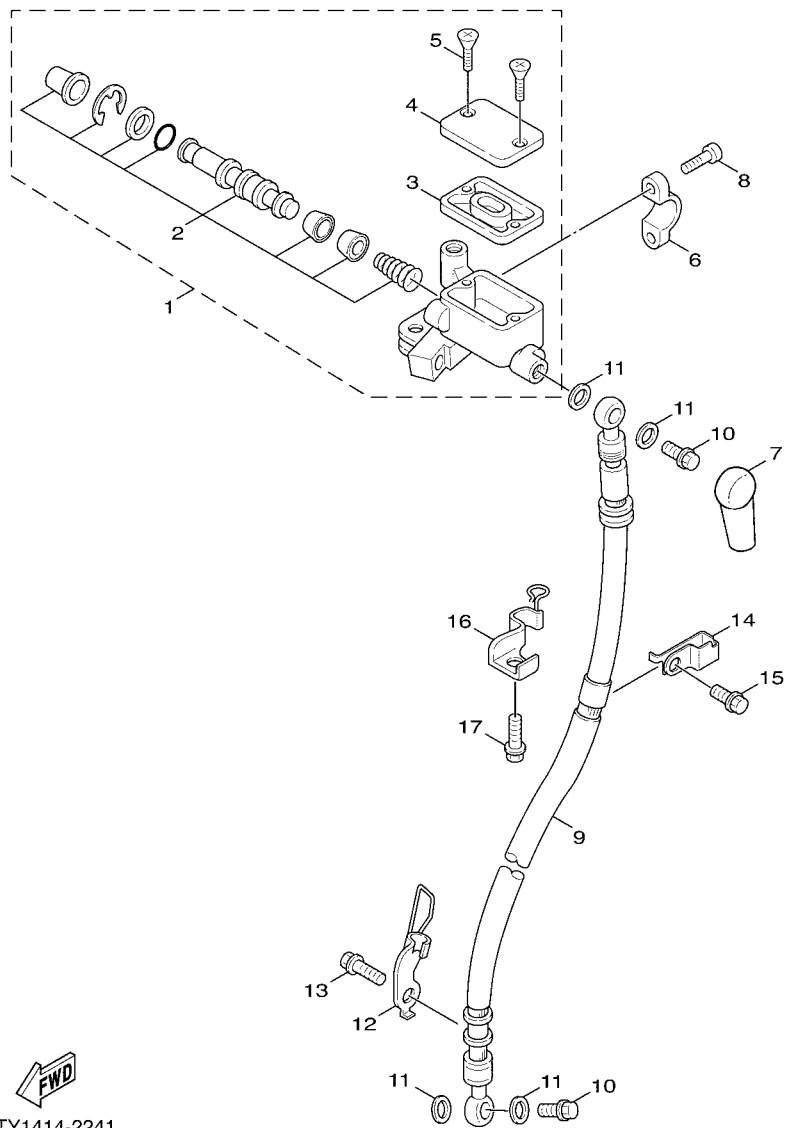

FIG. 23 STEERING HANDLE & CABLE

REF. NO.	PART NO.	DESCRIPTION	010	020	030	040	050	REMARKS
1	5ML-X2611-20	HANDLE COMP.	1	1	1	1	1	
2	5ML-F6113-00	.DAMPER	1	1	1	1	1	
3	90105-10036	BOLT, FLANGE	1	1	1	1	1	
4	90185-10801	NUT, SELF-LOCKING	1	1	1	1	1	
5	5ML-F6241-00	GRIP	1	1	1	1	1	
6	5ML-F6240-00	GRIP ASSY	1	1	1	1	1	
7	5ML-F6270-01	CABLE CONNECTOR CAP ASSY	1	1	1	1	1	
8	5ML-F6311-10	CABLE, THROTTLE 1	1	1	1	1	1	
9	98507-05010	SCREW, PAN HEAD	1	1	1	1	1	
10	90464-12812	CLAMP	1	1	1	1	1	
11	5ML-F6351-10	CABLE, BRAKE	1	1	1	1	1	
12	90179-06843	NUT	1	1	1	1	1	
13	90249-12008	PIN	1	1	1	1	1	
14	90501-16801	SPRING, COMPRESSION	1	1	1	1	1	
15	5ML-F637G-00	HOLDER, WIRE	1	1	1	1	1	
16	95807-06012	BOLT, FLANGE	1	1	1	1	1	
17	5ML-F637H-00	HOLDER, WIRE 2	1	1	1	1	1	
18	95827-06012	BOLT, FLANGE	1	1	1	1	1	
19	90464-12812	CLAMP	1	1	1	1	1	

FIG. 24 FRONT MASTER CYLINDER



5TY1414-2241

REF. NO.	PART NO.	DESCRIPTION	010	020	030	040	050	REMARKS
1	5ML-F5870-00	MASTER CYLINDER SUB ASSY	1	1	1	1	1	
2	5NW-W0041-00	.CYLINDER KIT, MASTER	1	1	1	1	1	
3	3GF-F5854-00	.DIAPHRAGM, RESERVOIR	1	1	1	1	1	
4	5ML-F5852-00	.CAP, RESERVOIR	1	1	1	1	1	
5	98780-04012	.SCREW, FLAT HEAD	1	1	1	1	1	
6	5ML-F5867-00	BRACKET, MASTER CYLINDER	1	1	1	1	1	
7	1MH-F5862-00	BOOT, MASTER CYLINDER	1	1	1	1	1	
8	91317-06025	BOLT	2	2	2	2	2	
9	5ML-F5872-10	HOSE, BRAKE 1	1	1	1	1	1	
10	90401-10805	BOLT, UNION	2	2	2	2	2	
11	90201-10118	WASHER, PLATE	4	4	4	4	4	
12	5ML-F5875-00	HOLDER, BRAKE HOSE 1	1	1	1	1	1	
13	95807-06012	BOLT, FLANGE	1	1	1	1	1	
14	5ML-F5876-00	HOLDER, BRAKE HOSE 2	1	1	1	1	1	
15	95807-06014	BOLT, FLANGE	1	1	1	1	1	
16	5ML-F5887-00	HOLDER, BRAKE HOSE	1	1	1	1	1	
17	95807-06014	BOLT, FLANGE	1	1	1	1	1	

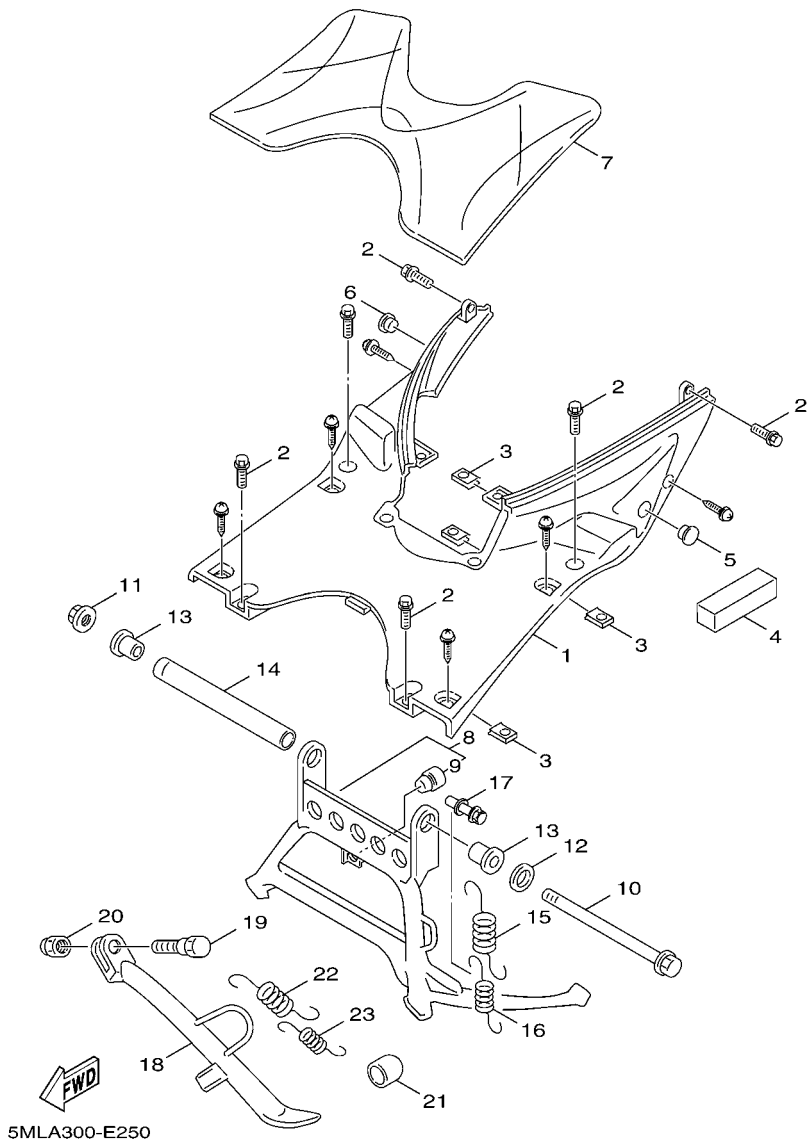

5MLA300-E250

FIG. 25 STAND & FOOTREST

REF. NO.	PART NO.	DESCRIPTION	010	020	030	040	050	REMARKS
1	5ML-F7481-00	BOARD, FOOTREST	1	1	1	1	1	
2	90119-06821	BOLT, WITH WASHER	6	6	6	6	6	
3	90183-05807	NUT, SPRING	8	8	8	8	8	
4	5ML-F1779-00	DAMPER, LOCATING 2	1	1	1	1	1	
5	3GF-F6199-00	PLUG, BLIND	1	1	1	1	1	
6	4DH-F6199-01	PLUG, BLIND	1	1	1	1	1	
7	5ML-F7483-10	MAT 1	1	1	1	1	1	
8	5ML-X2711-00	STAND, MAIN	1	1	1	1	1	
9	5ML-F7114-00	.STOPPER, MAIN STAND	1	1	1	1	1	
10	5ML-F7117-00	BOLT, MAIN STAND	1	1	1	1	1	
11	95604-08200	NUT, U FLANGE	1	1	1	1	1	
12	90201-08810	WASHER, PLATE	1	1	1	1	1	
13	5ML-F7121-00	BUSH	2	2	2	2	2	
14	5ML-F7113-00	COLLAR, MAIN STAND	1	1	1	1	1	
15	90506-35800	SPRING, TENSION	1	1	1	1	1	
16	90506-20803	SPRING, TENSION	1	1	1	1	1	
17	5ML-F7254-00	HOOK	1	1	1	1	1	
18	5ML-F7311-10	STAND, SIDE	1	1	1	1	1	
19	90109-10005	BOLT	1	1	1	1	1	
20	90185-10110	NUT, SELF-LOCKING	1	1	1	1	1	
21	5CA-F7114-00	STOPPER, MAIN STAND	1	1	1	1	1	
22	90506-26802	SPRING, TENSION	1	1	1	1	1	
23	90506-16801	SPRING, TENSION	1	1	1	1	1	

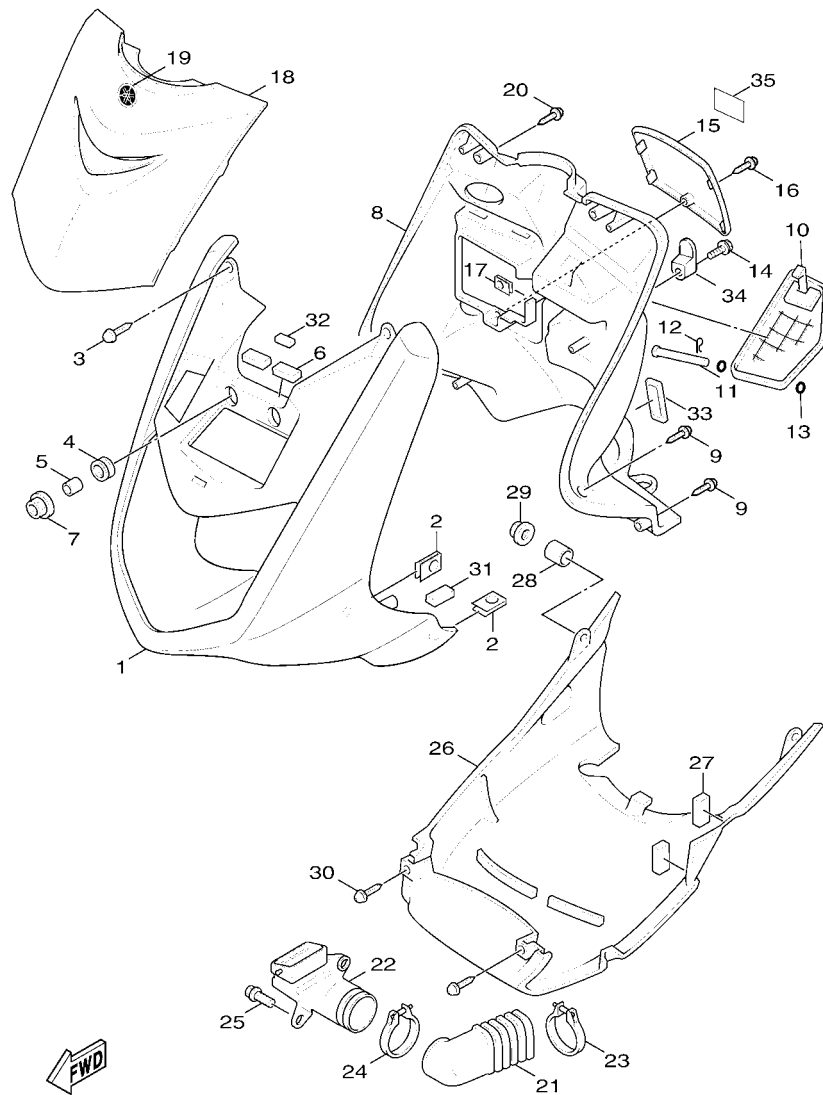

5UA1010-B261

FIG. 26 LEG SHIELD

REF. NO.	PART NO.	DESCRIPTION	010	020	030	040	050	REMARKS
1	5ML-F8311-00-7M	LEG SHIELD 1	1	1	1	1	1	UR MDS
	5ML-F8311-00-P0	LEG SHIELD 1	1	1	1	1	1	UR S1
	5ML-F8311-00-P4	LEG SHIELD 1				1		UR WM1
	5ML-F8311-00-P9	LEG SHIELD 1	1	1	1	1	1	UR LNBM8
2	90183-05807	NUT, SPRING	4	4	4	4	4	
3	97707-50016	SCREW, TAPPING	2	2	2	2	2	
4	90480-13398	GROMMET	2	2	2	2	2	
5	90387-067N5	COLLAR	2	2	2	2	2	
6	5ML-F834E-00	DAMPER 1	2	2	2	2	2	
7	95707-06500	NUT, FLANGE	2	2	2	2	2	
8	5ML-F8312-01	LEG SHIELD 2	1	1	1	1	1	
9	97707-50016	SCREW, TAPPING	6	6	6	6	6	
10	5ML-F8313-00	LID	1	1	1	1	1	
11	90240-05047	PIN, CLEVIS	1	1	1	1	1	
12	90468-12007	CLIP	1	1	1	1	1	
13	93210-058H0	O-RING	2	2	2	2	2	
14	90159-06822	SCREW, WITH WASHER	1	1	1	1	1	
15	5ML-H2129-00	COVER, BATTERY	1	1	1	1	1	
16	90169-05001	TAPPING SCREW	1	1	1	1	1	
17	90183-05807	NUT, SPRING	1	1	1	1	1	
18	5ML-F8345-00-7M	MOLE 1	1	1	1	1	1	UR MDS
	5ML-F8345-00-P0	MOLE 1	1	1	1	1	1	UR S1
	5ML-F8345-00-P4	MOLE 1				1		UR WM1
	5ML-F8345-00-PC	MOLE 1	1	1	1	1	1	UR LNBM8
19	5TY-F1569-00	GRAPHIC 1	1	1	1	1	1	
20	97707-50012	SCREW, TAPPING	2	2	2	2	2	
21	5ML-F838N-00	DUCT 1	1	1	1	1	1	

FIG. 27 COWLING 1



FWD
5TY1414-2270

REF. NO.	PART NO.	DESCRIPTION	010	020	030	040	050	REMARKS
1	5ML-F6143-10-7M	COVER, HANDLEBAR UPPER 1	1	1	1	1	1	UR MDS
	5ML-F6143-10-P0	COVER, HANDLEBAR UPPER 1	1	1	1	1	1	UR S1
	5ML-F6143-10-P2	COVER, HANDLEBAR UPPER 1				1		UR WM1
	5ML-F6143-10-P6	COVER, HANDLEBAR UPPER 1	1	1	1	1	1	UR LNBM8
2	90183-05807	NUT, SPRING	2	2	2	2	2	
3	90159-05028	SCREW, WITH WASHER	2	2	2	2	2	
4	90159-05802	SCREW, WITH WASHER	2	2	2	2	2	
5	97707-50016	SCREW, TAPPING	2	2	2	2	2	
6	5ML-F6145-00	COVER, HANDLEBAR UPPER 2	1	1	1	1	1	
7	97707-50016	SCREW, TAPPING	2	2	2	2	2	
8	5ML-F6234-00	SCREEN	1	1	1	1	1	
9	90269-06803	RIVET	2	2	2	2	2	
10	5ML-F6280-10	REAR VIEW MIRROR ASSY (LEFT)	1	1	1	1	1	
11	5ML-F6290-10	REAR VIEW MIRROR ASSY (RIGHT)	1	1	1	1	1	

D11

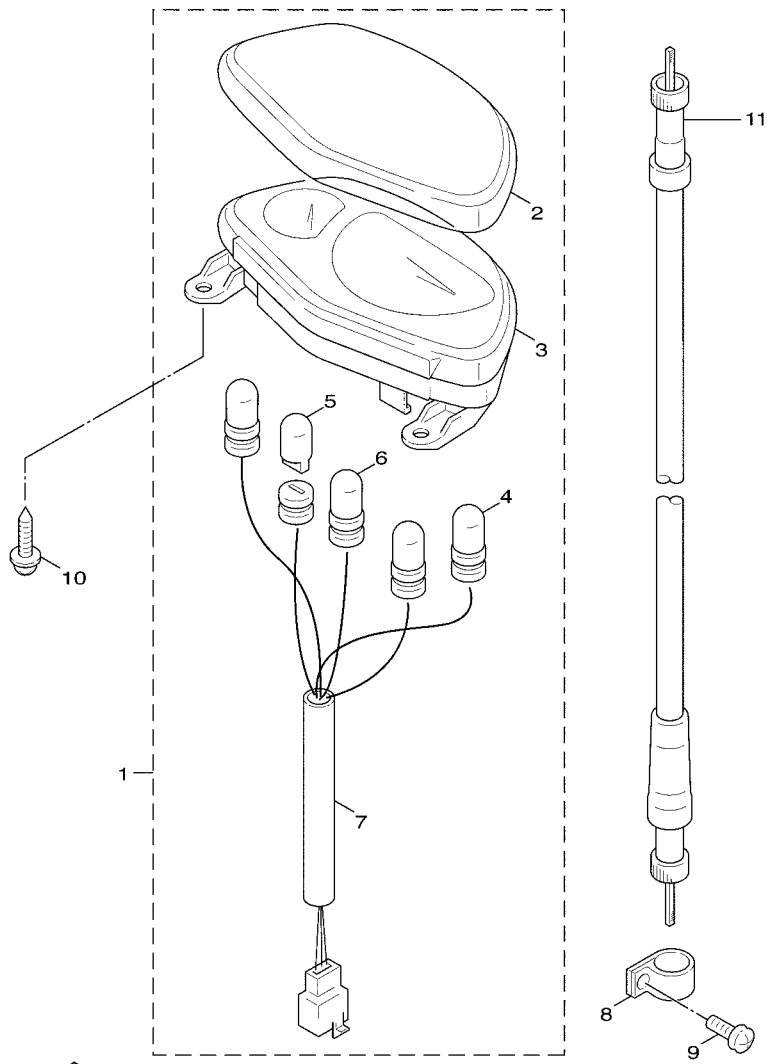
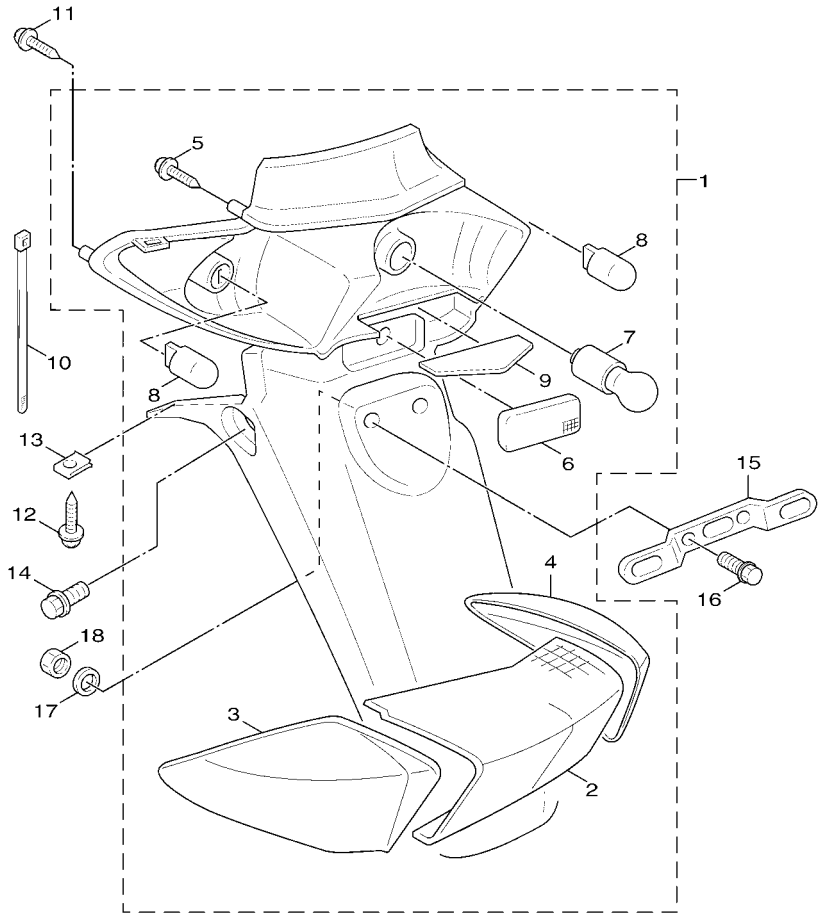

FIG. 31 METER

REF. NO.	PART NO.	DESCRIPTION	010	020	030	040	050	REMARKS
1	5ML-H3510-71	SPEEDOMETER ASSY	1	1	1	1	1	UR OTHERS
	5ML-H3510-81	SPEEDOMETER ASSY			1			UR GBR
2	5ML-H353E-10	.CASE, METER UPPER	1	1	1	1	1	
3	5ML-H353K-10	.GLASS PLATE	1	1	1	1	1	
4	1MH-H3517-10	.BULB	1	1	1	1	1	
5	3KW-H3517-10	.BULB	3	3	3	3	3	
6	3GF-H3517-10	.BULB	1	1	1	1	1	
7	5ML-H3509-10	.SOCKET CORD ASSY	1	1	1	1	1	
8	5ML-H3595-10	.CLAMP	1	1	1	1	1	
9	5ML-H3616-10	.SCREW, TAPPING	1	1	1	1	1	
10	97707-50016	SCREW, TAPPING	3	3	3	3	3	
11	5ML-H3550-10	SPEEDOMETER CABLE ASSY	1	1	1	1	1	

5TY1414-2311



5TY1414-2332

FIG. 33 TAILLIGHT

REF. NO.	PART NO.	DESCRIPTION	010	020	030	040	050	REMARKS
1	5ML-H4700-10	TAILLIGHT ASSY	1	1	1	1	1	
2	5ML-H4721-10	.LENS, TAILLIGHT	1	1	1	1	1	
3	5ML-H3332-20	.LENS, FLASHER	1	1	1	1	1	
4	5ML-H3342-20	.LENS, FLASHER 2	1	1	1	1	1	
5	97707-04616	.SCREW, TAPPING	2	2	2	2	2	
6	5CP-H5130-11	.REAR REFLECTOR ASSY	1	1	1	1	1	
7	4VP-H4714-10	.BULB	1	1	1	1	1	
8	5ML-H3311-10	.BULB, FLASHER	2	2	2	2	2	
9	5ML-H4743-10	.LENS, LICENCE LIGHT	1	1	1	1	1	
10	90464-50802	CLAMP	1	1	1	1	1	
11	97707-50016	SCREW, TAPPING	6	6	6	6	6	
12	97707-50012	SCREW, TAPPING	2	2	2	2	2	
13	90183-05807	NUT, SPRING	2	2	2	2	2	
14	90109-063F1	BOLT	2	2	2	2	2	
15	5ML-H4751-00	BRACKET, LICENSE	1	1	1	1	1	
16	95807-06014	BOLT, FLANGE	2	2	2	2	2	
17	90201-06557	WASHER, PLATE	2	2	2	2	2	
18	95607-06100	NUT, U	2	2	2	2	2	

FIG. 34 HANDLE SWITCH & LEVER

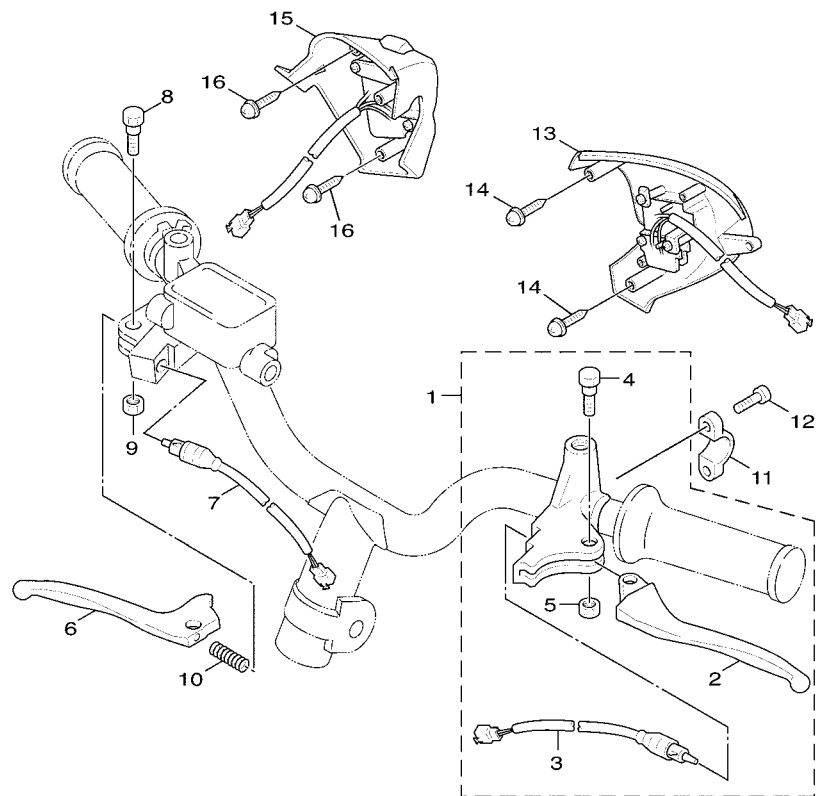

REF. NO.	PART NO.	DESCRIPTION	010	020	030	040	050	REMARKS
1	5ML-H2910-20	LEVER HOLDER ASSY (LEFT)	1	1	1	1	1	
2	5ML-H3912-10	.LEVER 1	1	1	1	1	1	
3	5ML-H3980-20	.FRONT STOP SWITCH ASSY	1	1	1	1	1	
4	5NV-H3945-10	.BOLT, LEVER	1	1	1	1	1	
5	95607-05100	.NUT, U	1	1	1	1	1	
6	5ML-H3922-00	LEVER 2	1	1	1	1	1	
7	5ML-H3980-20	FRONT STOP SWITCH ASSY	1	1	1	1	1	
8	90109-06577	BOLT	1	1	1	1	1	
9	95607-06100	NUT, U	1	1	1	1	1	
10	90501-10312	SPRING, COMPRESSION	1	1	1	1	1	
11	3GF-F5867-00	BRACKET, MASTER CYLINDER	1	1	1	1	1	
12	91317-06025	BOLT	2	2	2	2	2	
13	5UA-H3973-20	SWITCH, HANDLE 3	1	1	1	1	1	
14	97707-50016	SCREW, TAPPING	2	2	2	2	2	
15	5UA-H3976-20	SWITCH, HANDLE 1	1	1	1	1	1	
16	97707-50016	SCREW, TAPPING	2	2	2	2	2	



5TY1414-2340

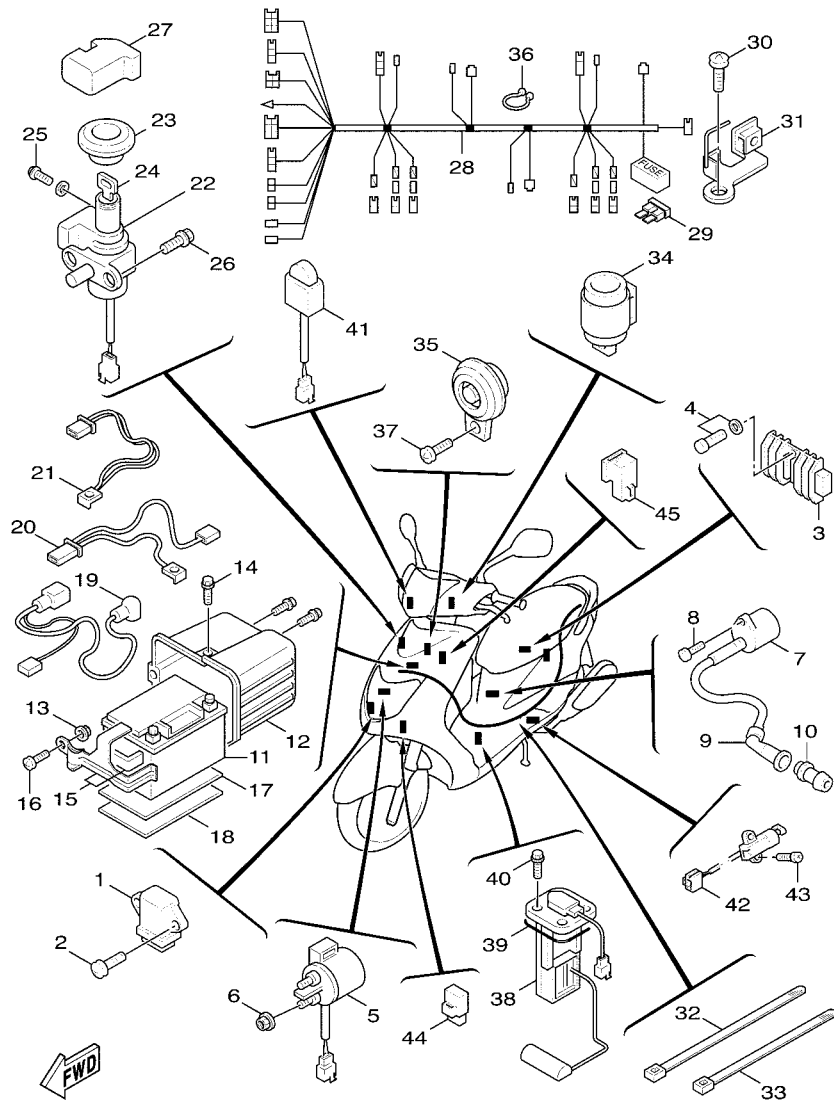

5UA1010-B351

FIG. 35 ELECTRICAL 1

REF. NO.	PART NO.	DESCRIPTION	010	020	030	040	050	REMARKS
1	5ML-H5540-00	C.D.I. UNIT ASSY	1	1	1	1	1	
2	97707-50014	SCREW, TAPPING	2	2	2	2	2	
3	5ML-H1960-00	RECTIFIER & REGULATOR ASSY	1	1	1	1	1	
4	97607-06220	SCREW, WITH WASHER	2	2	2	2	2	
5	5ML-H1940-10	STARTER RELAY ASSY	1	1	1	1	1	
6	95307-06700	NUT	2	2	2	2	2	
7	5ML-H2310-00	IGNITION COIL ASSY	1	1	1	1	1	
8	98507-05020	SCREW, PAN HEAD	1	1	1	1	1	
9	5ML-H2370-01	PLUG CAP ASSY	1	1	1	1	1	
10	5ML-H2372-00	SEAL, PLUG CAP	1	1	1	1	1	
11	4CW-H2100-00	BATTERY ASSY	1	1	1	1	1	
12	5ML-H212B-00	BOX, BATTERY 1	1	1	1	1	1	
13	2GF-F1535-00	NUT 1	1	1	1	1	1	
14	90109-063F1	BOLT	3	3	3	3	3	
15	5ML-X8213-00	BAND ASSY	1	1	1	1	1	
16	90159-06033	SCREW, WITH WASHER	1	1	1	1	1	
17	5ML-H2122-00	SEAT, BATTERY	1	1	1	1	1	
18	5ML-H2121-00	PAD, BATTERY	1	1	1	1	1	
19	5ML-H2115-10	WIRE, PLUS LEAD	1	1	1	1	1	
20	5ML-H2116-10	WIRE, MINUS LEAD	1	1	1	1	1	
21	5ML-H2541-10	WIRE, LEAD	1	1	1	1	1	
22	5ML-H2501-20	MAIN SWITCH STEERING LOCK	1	1	1	1	1	
23	5ML-H2552-10	CAP, SWITCH	1	1	1	1	1	
24	5ML-H2511-20-A0	KEY, MAIN SWITCH	1	1	1	1	1	
	5ML-H2511-20-B0	KEY, MAIN SWITCH	1	1	1	1	1	
25	97607-05212	SCREW, WITH WASHER	1	1	1	1	1	
26	90149-06811	SCREW	2	2	2	2	2	

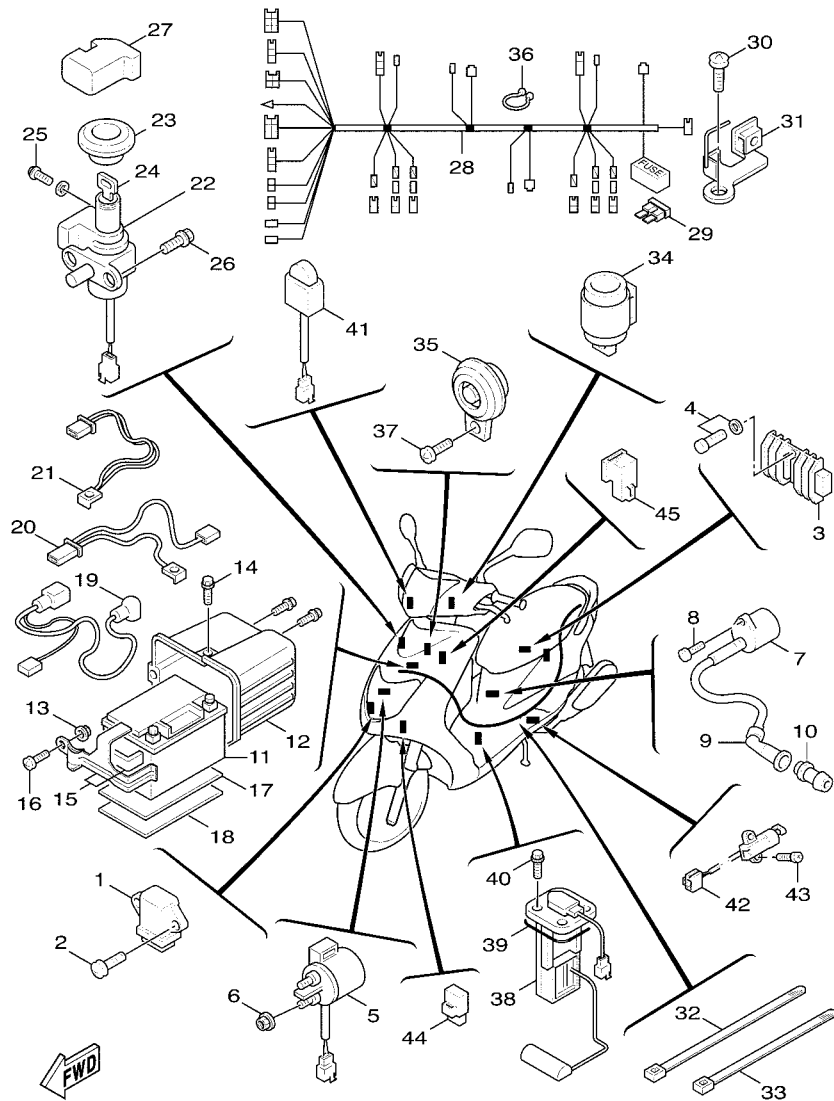

5UA1010-B351

FIG. 35 ELECTRICAL 1

REF. NO.	PART NO.	DESCRIPTION	010	020	030	040	050	REMARKS
27	5ML-H2155-01	BAND	1	1	1	1	1	
28	5ML-H2590-10	WIRE HARNESS ASSY	1	1	1	1	1	
29	5ML-H2151-00	.FUSE (30A)	2	2	2	2	2	
	5ML-H2151-10	.FUSE (15A)	3	3	3	3	3	
	5ML-H2151-20	.FUSE (7.5A)	3	3	3	3	3	
30	95707-06500	NUT, FLANGE	2	2	2	2	2	
31	5ML-H2915-01	HOLDER, LEVER UNDER	1	1	1	1	1	
32	90464-20809	CLAMP	2	2	2	2	2	
33	90464-12812	CLAMP	2	2	2	2	2	
34	5ML-H3350-00	FLASHER RELAY ASSY	1	1	1	1	1	
35	5ML-H3371-00	HORN	1	1	1	1	1	
36	90464-16801	CLAMP	1	1	1	1	1	
37	98507-06010	SCREW, PAN HEAD	1	1	1	1	1	
38	5ML-X8575-10	SENDER UNIT ASSY	1	1	1	1	1	
39	53X-H5753-00	.GASKET, SENDER UNIT	1	1	1	1	1	
40	90119-05071	BOLT, WITH WASHER	4	4	4	4	4	
41	5FU-82560-40	THERMO SWITCH ASSY	1	1	1	1	1	
42	3LD-82566-40	SWITCH, SIDE STAND	1	1	1	1	1	
43	90157-05079	SCREW, PAN HEAD	2	2	2	2	2	
44	4HC-81950-00	RELAY ASSY	1	1	1	1	1	
45	29U-81950-93	RELAY ASSY	1	1	1	1	1	

NUMERICAL INDEX

PART NO.	GRID NO.	PART NO.	GRID NO.	PART NO.	GRID NO.	PART NO.	GRID NO.	PART NO.	GRID NO.	PART NO.	GRID NO.
5ML-12113-00	B - 5	5HK-E2156-00	B - 5	5TY-E4435-10	B - 8	5ML-E5362-00	B - 14	5ML-F117G-00	C - 7	5ML-F1779-00	D - 8
1AA-12118-00	B - 5	4CW-E2157-00	B - 5	5TY-E443E-10	B - 8	4Y4-E5363-00	B - 13	5ML-F1208-00	C - 7	5CA-F1823-00	D - 10
663-14159-00	B - 9	5FM-E2159-00	B - 5	5JS-E4445-00	B - 11	5CA-E5371-00	B - 13	5ML-F1268-00	C - 7	5ML-F2171-00	C - 11
4JH-14160-00	B - 9	1P3-E2161-00	B - 5	5TY-E4449-10	B - 8	5ML-E5404-00	B - 14	5ML-F139X-00	D - 2	5ML-F2210-10	C - 11
3TJ-14191-40	B - 10	1P3-E2170-00	B - 5	5TY-E4451-10	B - 8	5ML-E5407-00	B - 14	5UA-F1415-00	C - 6	4X6-F2216-00	B - 13
5JG-14531-00	B - 9	5LW-E2176-00	B - 5	5TY-E4476-10	B - 8	5ML-E5411-00	B - 13	5ML-F1420-01	C - 6		C - 11
3TJ-14562-40	B - 9	5ML-E2210-00	B - 5	5ML-E4590-00	B - 10	5ML-E5417-00	B - 14	5ML-F1480-10	C - 6	5ML-F2417-00	C - 8
3TJ-14564-40	B - 10	4DH-E2213-01	B - 5	5ML-E4592-00	B - 10	5ML-E5421-00	B - 13	3UH-F1481-00	C - 6	5ML-F3100-11-35	C - 12
688-14592-00	B - 9	5ML-E2231-00	B - 5	5ML-E4610-00-98	B - 11	5ML-E5422-00	B - 13	5ML-F1481-00	C - 6	5TY-F3102-10-35	C - 12
4DH-14613-00	B - 11	5UA-E2232-00	B - 5	5JS-E4617-00	B - 11	5ML-E5451-10	B - 13	5ML-F1511-10-7M	C - 8	5ML-F3103-10-35	C - 12
5BE-14937-00	B - 9	5ML-E2241-00	B - 5	5ML-E4708-00	B - 11	5ML-E5453-00	B - 14	5ML-F1511-10-P0	C - 8	5ML-F3110-10	C - 12
3TJ-14952-40	B - 9	5UA-E2611-00	B - 6	5JS-E4759-00	B - 11	5ML-E5455-00	B - 14	5ML-F1511-10-P2	C - 8	3UH-F3114-00	C - 12
22F-23411-01	C - 13	5ML-E2651-00	B - 6	4CW-E4766-00	B - 11	5ML-E5461-00	B - 13	5ML-F1511-10-P6	C - 8	5ML-F3126-10-35	C - 12
156-23412-00	C - 13	5ML-E2652-00	B - 6	5JS-E4779-00	B - 11	5ML-E5472-00	B - 14	5ML-F151B-00	C - 8	5ML-F3136-10-35	C - 12
22F-23412-01	C - 13	5ML-E2653-01	B - 6	5ML-E4803-10	B - 11	4DM-E5481-00	B - 14	2GF-F1535-00	D - 2	5ML-F3141-10	C - 12
156-2341E-00	C - 13	5ML-E2658-00	B - 6	5ML-E4806-10	B - 12	5ML-E5481-00	B - 13		E - 5	5ML-F3145-10	C - 12
22F-2341E-00	C - 13	5ML-E2659-00	B - 6	5ML-E4815-00	B - 11	5CA-E5521-00	C - 2	5ML-F1541-00	C - 7	5ML-F3156-10	C - 12
4HC-81950-00	E - 6	5ML-E2668-00	B - 6	5ML-E4854-00	B - 10	5TY-E5524-00	C - 2	5ML-F1544-01	C - 6	3UH-F3158-00	C - 12
29J-81950-93	E - 6	5ML-E2682-00	B - 6	5ML-E4871-00	B - 11	5ML-E5532-00	C - 2	5ML-F1552-00	C - 8	5ML-F3171-10	C - 12
5FU-82560-40	E - 6	5ML-E3300-00	B - 7	5TY-E4871-00	B - 10	5LW-E5538-00	C - 2	5TY-F1569-00	D - 9	3UH-F3173-00	C - 12
3LD-82566-40	E - 6	5ML-E3324-00	B - 4	5ML-E4883-00	B - 11	5TY-E5570-00	C - 2	5ML-F162H-00	C - 6	3UH-F3181-00	C - 12
1P3-E1102-00	B - 2	5ML-E3325-00	B - 7	5ML-E4884-10	B - 11	5ML-E5601-00	C - 2	5ML-F162J-00	C - 6	5ML-F3317-00	C - 13
5ML-E111F-00	B - 5	5ML-E3411-00	B - 7	5ML-E4885-10	B - 12	5ML-E5620-00	C - 2	5CA-F1639-00	C - 8	5ML-F331G-10	C - 12
1P3-E1133-10	B - 2	5ML-E3416-00	B - 13	5ML-E4901-10	B - 9	5TY-E5645-00	C - 2	5ML-F1639-00	C - 7	5ML-F3340-10	C - 13
1P3-E1134-10	B - 2	5ML-E3452-00	B - 4	5ML-E4916-00	B - 9	5ML-E5650-00	C - 2	5ML-F1652-00	C - 7	5TY-F3346-00	C - 13
5ML-E1145-00	B - 5	5ML-E3474-00	B - 8	5TY-E4922-00	B - 9	5ML-E5657-00	C - 3	5ML-F1711-00	C - 9	5ML-F3356-10	C - 12
4CW-E1155-00	B - 2	5ML-E3475-00	B - 7	5TY-E4933-00	B - 9	5ML-E5659-00	C - 2	5ML-F171L-00-7M	C - 9	1MH-F3411-00	C - 13
5ML-E1160-00	B - 2	5ML-E3542-00	B - 12	5TY-E4936-00	B - 9	5ML-E5670-00	C - 2	5ML-F171L-00-P0	C - 9	4TE-F3416-00	C - 13
5ML-E1165-00	B - 2	5ML-E3556-00	B - 8	5TY-E4940-00	B - 9	5ML-E5673-00	C - 2	5ML-F171L-00-P4	C - 9	4VP-F3418-00	C - 13
5ML-E1181-00	B - 2	3KW-E3569-00	B - 6	5TY-E4943-28	B - 9	5ML-E6111-01	C - 3	5ML-F171L-00-P9	C - 9	3KW-F3462-00	C - 13
5ML-E1185-00	B - 2	5ML-E3575-00	B - 8	5ML-E4945-00	B - 10	4CW-E6611-00	C - 3	5ML-F171M-00-7M	C - 10	5ML-F4110-00-33	C - 14
5ML-E1186-00	B - 2	5ML-E3585-10	B - 8	5TY-E4947-00	B - 9	4TE-E6620-01	C - 3	5ML-F171M-00-P0	C - 10	5ML-F4115-00	C - 14
5ML-E1311-00	B - 2	5ML-E3595-00	B - 8	5ML-E4948-01	B - 9	4CW-E6626-00	C - 3	5ML-F171M-00-P4	C - 10	5ML-F414A-00	C - 15
5ML-E1351-01	B - 2	5ML-E3769-00	B - 14	5TY-E4958-00	B - 9	5ML-E7211-01	C - 5	5ML-F171M-00-P9	C - 10	5ML-F4180-00	C - 14
5ML-E1391-00	B - 3	5UA-E3910-01	C - 15	5TY-E4967-00	B - 9	5ML-E7410-01	C - 5	5ML-F1721-01-7M	C - 9	5ML-F4181-00	C - 14
5ML-E1392-00	B - 3	5ML-E3929-00	C - 15	5ML-E4969-00	B - 10	5ML-E7421-01	C - 5	5ML-F1721-01-P0	C - 9	5ML-F4183-00	C - 14
5ML-E1400-02	B - 4	5ML-E414G-00	B - 9	5TY-E4984-00	B - 10	4HP-E7611-00	C - 3	5ML-F1721-01-P4	C - 9	5ML-F4280-00	C - 14
5ML-E1422-00	B - 4	5TY-E4196-00	B - 9	5TY-E4985-00	B - 9	5ML-E7620-02	C - 3	5ML-F1721-01-PB	C - 9	5ML-F4311-01	C - 14
5ML-E1603-00	B - 4	5TY-E4197-00	B - 9	5ML-E4987-00	B - 2	5ML-E7623-00	C - 3	5ML-F1731-01-7M	C - 9	5ML-F4312-01	C - 14
5ML-E1631-10	B - 4	5TY-E4245-00	B - 9	5TY-E4994-00	B - 9	5ML-E7632-00	C - 3	5ML-F1731-01-P0	C - 9	5ML-F4313-00	C - 14
5LW-E1633-00	B - 4	5TY-E4245-10	B - 9	5ML-E5111-00	B - 13	5ML-E7641-00	C - 3	5ML-F1731-01-P4	C - 9	5ML-F4314-00	C - 15
5LW-E1651-00	B - 4	5ML-E4294-00	C - 15	5ML-E5113-00	B - 14	5TY-E7644-01	C - 3	5ML-F1731-01-PB	C - 9	5ML-F4316-00	C - 14
5ML-E1681-00	B - 4	5UA-E4370-10	B - 9	5ML-E5138-00	B - 13	5ML-E7653-01	C - 3	5ML-F1732-00	C - 9	5ML-F4317-00	C - 14
5ML-E2111-00	B - 5	5ML-E4386-00	B - 10	5ML-E5158-00	B - 14	4CW-E7660-01	C - 3	5ML-F173B-00	C - 9	5ML-F4318-00	C - 15
1P3-E2117-00	B - 5	5TY-E4408-10	B - 8	5ML-E5191-00	B - 14	4CW-E7664-00	C - 3	5ML-F1746-00	C - 9	5ML-F4339-00	C - 14
5ML-E2119-00	B - 5	5TY-E4410-10	B - 8	5ML-E5328-00	B - 14	4KP-E7670-00	C - 3	5ML-F174B-00	C - 9	3UH-F4376-00	C - 15
5ML-E2121-00	B - 5	5TY-E4429-10	B - 8	5ML-E5338-00	B - 14	5ML-F1110-01-33	C - 6	5ML-F1753-01	C - 15	5ML-F4491-00	D - 2
1P3-E2151-00	B - 5	5TY-E442G-10	B - 8	5ML-E5351-00	B - 7	5ML-F1161-01	C - 6	5ML-F176M-00	C - 9	5CA-F4560-00	C - 14

NUMERICAL INDEX

PART NO.	GRID NO.	PART NO.	GRID NO.	PART NO.	GRID NO.	PART NO.	GRID NO.	PART NO.	GRID NO.	PART NO.	GRID NO.
5ML-F4602-00	C - 14	5ML-F6234-00	D - 11	4CW-H2100-00	E - 5	5UA-H3973-20	E - 4	90105-10638	D - 4	90185-10801	C - 6
5ML-F4723-00	D - 2	5ML-F6240-00	D - 6	5UA-H2103-00	B - 10	5UA-H3976-20	E - 4	90109-063F1	B - 12		D - 6
5UA-F4726-00	D - 2	5ML-F6241-00	D - 6	5ML-H2115-10	E - 5	5ML-H3980-20	E - 4		D - 2	90185-14124	D - 5
5ML-F4730-00	D - 2	5ML-F6270-01	D - 6	5ML-H2116-10	E - 5	5ML-H430A-20	E - 2		D - 10	90201-06055	B - 11
5ML-F473R-01	D - 2	5ML-F6280-10	D - 11	5ML-H2121-00	E - 5	5ML-H430A-30	E - 2		E - 3	90201-06072	C - 14
5ML-F473T-00	D - 2	5ML-F6290-10	D - 11	5ML-H2122-00	E - 5	5ML-H4310-20	E - 2		E - 5	90201-06557	E - 3
5ML-F475M-01	D - 2	5ML-F6311-10	D - 6	5ML-H2129-00	D - 9	5ML-H4310-30	E - 2	90109-06577	E - 4	90201-077F5	B - 7
4UE-F4780-02	D - 2	5ML-F6351-10	D - 6	5ML-H212B-00	E - 5	5ML-H4312-10	E - 2	90109-06802	B - 8	90201-08609	B - 2
5ML-F478E-10	D - 2	5ML-F637G-00	D - 6	5ML-H2151-00	E - 6	3YB-H4314-10	E - 2	90109-06876	C - 8	90201-08810	D - 8
5ML-F478W-00	D - 10	5ML-F637H-00	D - 6	5ML-H2151-10	E - 6	5FM-H4347-10	E - 2	90109-10005	D - 8	90201-10118	D - 7
5ML-F4812-00-7M	D - 2	5ML-F7113-00	D - 8	5ML-H2151-20	E - 6	5CA-H4396-10	E - 2	90110-06813	B - 13	90201-101J1	B - 11
5ML-F4812-00-P0	D - 2	5CA-F7114-00	D - 8	5ML-H2155-01	E - 6	5ML-H4700-10	E - 3	90110-06815	B - 13		C - 11
5ML-F4812-00-P4	D - 2	5ML-F7114-00	D - 8	5ML-H2310-00	E - 5	4VP-H4714-10	E - 3	90111-06801	B - 11	90201-105A2	C - 6
5ML-F4812-00-PA	D - 2	5ML-F7117-00	D - 8	5ML-H2370-01	E - 5	5ML-H4721-10	E - 3	90113-06803	B - 2	90201-108A3	C - 2
5ML-F5168-00-35	D - 3	5ML-F7121-00	D - 8	5ML-H2372-00	E - 5	5ML-H4743-10	E - 3	90116-08806	B - 2	90201-12172	B - 15
5ML-F5181-00	D - 3	5ML-F7254-00	D - 8	5ML-H2501-20	E - 5	5ML-H4751-00	E - 3	90119-05071	E - 6	90201-12688	D - 12
5ML-F5183-00	D - 3	5ML-F7311-10	D - 8	5ML-H2511-20-A0	E - 5	5CP-H5130-11	E - 3	90119-06821	C - 8	90201-144M8	C - 3
5UA-F5190-00	D - 3	5ML-F7481-00	D - 8	5ML-H2511-20-B0	E - 5	5ML-H5540-00	E - 5		D - 8	90201-155G5	C - 2
5ML-F5326-00	D - 5	5ML-F7483-10	D - 8	5ML-H2541-10	E - 5	53X-H5753-00	E - 6	90119-06856	C - 14	90201-15803	C - 5
5ML-F5338-00-35	D - 5	5ML-F8100-00	C - 7	5ML-H2552-10	E - 5	5NW-W0041-00	D - 7	90119-06857	B - 6	90201-16802	C - 2
4VP-F533A-00	D - 5	5JS-F8257-40	D - 10	5ML-H2590-10	E - 6	5NW-W0045-00	D - 4	90119-08821	D - 2		C - 3
5ML-F5351-00	D - 5	5ML-F8311-00-7M	D - 9	5ML-H2910-20	E - 4	5NW-W0047-00	D - 4	90149-06811	E - 5	90201-20276	D - 5
5CA-F5355-00	D - 5	5ML-F8311-00-P0	D - 9	5ML-H2915-01	E - 6	5AG-W0048-00	D - 4	90149-08814	D - 4	90202-15803	C - 6
5ML-F5377-00	D - 5	5ML-F8311-00-P4	D - 9	5ML-H3310-10	D - 14	5NW-W0057-00	D - 4	90153-06803	B - 2	90202-26142	C - 13
5ML-F580U-00	D - 4	5ML-F8311-00-P9	D - 9	5FM-H3311-10	D - 14	5ML-W1141-02	B - 4	90154-06807	C - 8	90208-12050	C - 3
5ML-F582U-00	D - 4	5ML-F8312-01	D - 9	5ML-H3311-10	E - 3	5TY-W1442-10	B - 8	90157-05079	E - 6	90208-15801	C - 5
5AG-F5845-00	D - 4	5ML-F8313-00	D - 9	5ML-H331J-10	D - 14	5ML-W1512-01	B - 13	90159-05028	D - 11	90208-25800	C - 5
5ML-F5852-00	D - 7	5ML-F8345-00-7M	D - 9	5ML-H331R-10	D - 14	5ML-W8180-00	D - 13	90159-05802	D - 11	90240-05047	D - 9
3GF-F5854-00	D - 7	5ML-F8345-00-P0	D - 9	5ML-H3320-10	D - 14	5ML-X1543-00	B - 14	90159-06033	E - 5	90241-10015	D - 2
1MH-F5862-00	D - 7	5ML-F8345-00-P4	D - 9	5ML-H3332-20	E - 3	5ML-X1547-00	B - 14	90159-06822	D - 9	90249-12008	D - 6
3GF-F5867-00	E - 4	5ML-F8345-00-PC	D - 9	5ML-H3342-20	E - 3	5ML-X2161-00	C - 8	90169-05001	D - 9	90269-06803	D - 11
5ML-F5867-00	D - 7	5FM-F8349-00	D - 10	5ML-H3350-00	E - 6	5ML-X2533-00	D - 5	90170-05800	B - 5	90280-03045	B - 4
5ML-F5870-00	D - 7	5ML-F834E-00	D - 9	5ML-H3371-00	E - 6	5ML-X2611-20	D - 6	90170-36279	C - 4	90340-12802	B - 14
5ML-F5872-10	D - 7	5ML-F836T-00	D - 10	5ML-H3509-10	D - 15	5ML-X2711-00	D - 8	90176-08816	B - 2	90380-15817	C - 2
5ML-F5875-00	D - 7	5ML-F836U-00	D - 10	5ML-H3510-71	D - 15	5ML-X2838-00	D - 10	90179-06843	D - 6	90387-061N6	B - 11
5ML-F5876-00	D - 7	5ML-F8372-00	D - 10	5ML-H3510-81	D - 15	5ML-X8213-00	E - 5	90179-08804	B - 11	90387-062M9	C - 8
5ML-F5887-00	D - 7	5ML-F838N-00	D - 9	1MH-H3517-10	D - 15	5ML-X8575-10	E - 6	90179-12248	D - 12		D - 10
5NW-F5914-00	D - 4	5ML-F838R-00	D - 10	3GF-H3517-10	D - 15	90101-06291	D - 5	90179-14427	C - 3	90387-067N5	D - 9
5NW-F5919-00	D - 4	5ML-F842M-00	C - 7	3KW-H3517-10	D - 15	90101-10875	C - 11	90179-25615	C - 13	90387-06819	B - 14
5NW-F5919-10	D - 4	5ML-F8457-00	C - 7	5ML-H353E-10	D - 15	90105-06806	B - 14	90183-05807	C - 8	90387-068F9	B - 6
5ML-F6113-00	D - 6	5ML-H1410-10	D - 12	5ML-H353K-10	D - 15	90105-06807	B - 14		C - 9	90387-07598	C - 14
5ML-F6143-10-7M	D - 11	5TY-H1450-10	D - 12	5ML-H3550-10	D - 15	90105-06808	B - 13		C - 15	90387-125J1	D - 3
5ML-F6143-10-P0	D - 11	5ML-H1800-00	D - 13	5ML-H3595-10	D - 15	90105-06809	B - 14		D - 2	90387-153N8	C - 11
5ML-F6143-10-P2	D - 11	3KW-H1801-00	D - 13	5ML-H3616-10	D - 15	90105-06810	B - 13		D - 8	90387-15423	C - 11
5ML-F6143-10-P6	D - 11	3UH-H1828-01	D - 13	5UA-H3790-00	B - 10	90105-06817	B - 13		D - 9	90387-16801	C - 3
5ML-F6145-00	D - 11	5ML-H183G-00	D - 13	5ML-H3912-10	E - 4	90105-08121	C - 11		D - 11	90401-10805	D - 7
3GF-F6199-00	D - 8	5ML-H1940-10	E - 5	5ML-H3922-00	E - 4	90105-08835	B - 11		E - 3	90430-06014	B - 2
4DH-F6199-01	D - 8	5ML-H1960-00	E - 5	5NV-H3945-10	E - 4	90105-10036	D - 6	90185-10110	D - 8	90430-08816	B - 13

NUMERICAL INDEX

PART NO.	GRID NO.	PART NO.	GRID NO.	PART NO.	GRID NO.	PART NO.	GRID NO.	PART NO.	GRID NO.	PART NO.	GRID NO.
90446-13803	B - 13	90506-20803	D - 8	93315-110Y6	C - 2	97607-06220	B - 6				
90450-53061	D - 10	90506-26802	D - 8	93450-16068	B - 4		E - 5				
90450-60001	C - 14	90506-35800	D - 8	93602-13832	B - 7	97607-06225	D - 12				
90461-15801	C - 15	90508-32609	C - 2	93610-20800	B - 13	97707-04616	E - 3				
90464-07800	C - 6	91317-06012	B - 5	93900-00802	D - 3	97707-50012	C - 9				
90464-09801	C - 6	91317-06016	B - 5		D - 5		D - 2				
90464-10800	C - 6	91317-06025	D - 7	94111-12802	D - 3		D - 9				
90464-11801	C - 6		E - 4	94112-12801	D - 5		D - 14				
90464-12812	D - 6	91317-06030	C - 2	94568-75094	B - 5		E - 3				
	E - 6	91317-06100	B - 2	94701-00840	B - 2	97707-50014	C - 15				
90464-13800	B - 12	91810-14807	B - 2	95027-06010	B - 14		E - 5				
90464-16801	E - 6		B - 13		C - 15	97707-50016	C - 8				
90464-16803	C - 6	93101-21170	C - 3	95027-06012	C - 2		D - 9				
90464-18803	C - 6	93102-17853	D - 3	95027-06016	B - 3		D - 11				
90464-20803	B - 12	93102-19293	B - 14	95027-06020	B - 2		D - 14				
	C - 6	93102-22800	C - 3	95307-06700	E - 5		D - 15				
90464-20809	E - 6	93102-22843	B - 13	95307-10800	C - 11		E - 3				
90464-23811	B - 8	93102-26852	C - 5	95307-12700	C - 3		E - 4				
90464-25803	C - 6	93104-41801	C - 3	95604-08200	D - 8	97707-60020	E - 2				
90464-50802	E - 3	93106-26823	C - 11	95607-05100	E - 4	97707-60516	B - 6				
90465-13275	C - 6	93109-28811	C - 11	95607-06100	E - 3	97707-60530	B - 6				
90467-08003	C - 14	93210-058H0	D - 9		E - 4	98502-04012	B - 9				
90467-08092	B - 12	93210-09802	B - 2	95607-12200	D - 3	98507-05010	D - 2				
90467-09006	C - 14	93210-09859	D - 5	95707-06500	B - 11		D - 6				
90467-10008	C - 15	93210-14802	D - 5		D - 2	98507-05020	B - 7				
90467-10041	C - 15	93210-14805	B - 13		D - 9		E - 5				
90467-12052	B - 13	93210-15862	B - 5		E - 6	98507-06010	E - 6				
90467-13042	B - 3	93210-26668	D - 13	95707-10500	D - 5	98507-06014	C - 8				
90467-13813	B - 8	93210-27800	B - 8	95807-06010	C - 6	98507-06016	D - 12				
90467-16829	B - 11	93210-29800	B - 7	95807-06012	D - 2	98780-04012	D - 7				
90467-18830	B - 11	93210-43800	C - 3		D - 6	98907-06016	B - 14				
90467-20810	C - 14	93210-54003	B - 2		D - 7	98907-06020	B - 14				
90468-08812	B - 11	93210-55669	D - 13	95807-06014	D - 7	99001-05600	B - 7				
	C - 14	93210-71462	B - 2		E - 3	99009-15400	C - 2				
90468-12007	D - 9	93211-07801	B - 14	95807-06016	D - 2	99009-25400	C - 5				
90480-01326	C - 14	93306-003Y4	B - 15	95807-06030	B - 8	99480-05010	B - 14				
90480-10332	B - 11	93306-201Y7	D - 3	9580L-06020	C - 13						
90480-12497	B - 6	93306-20324	C - 4	95817-08016	B - 5						
90480-13398	D - 9	93306-204YH	C - 5		B - 13						
90480-14810	B - 11	93306-27210	C - 3	95817-10035	B - 11						
90480-18290	C - 14	93306-30113	C - 5	95827-06012	D - 6						
90501-10312	E - 4	93306-301YA	D - 3	95827-06025	C - 14						
90501-16004	B - 7	93306-302X1	C - 11	95827-08040	C - 11						
90501-16801	D - 6	93306-303Y8	C - 5	95827-10045	C - 6						
90501-43801	C - 3	93306-372Y3	B - 4	97007-06014	B - 11						
90506-13800	D - 5	93310-450X2	C - 2	97507-06525	D - 13						
90506-16801	D - 8	93310-528Y9	B - 4	97527-06512	B - 2						
90506-16802	D - 5	93311-315Y2	C - 5	97607-05212	E - 5						