

YAMAHA

PARTS CATALOGUE

TT500G (2Y0)

LIT-10012-Y0-01

102Y0-100E1

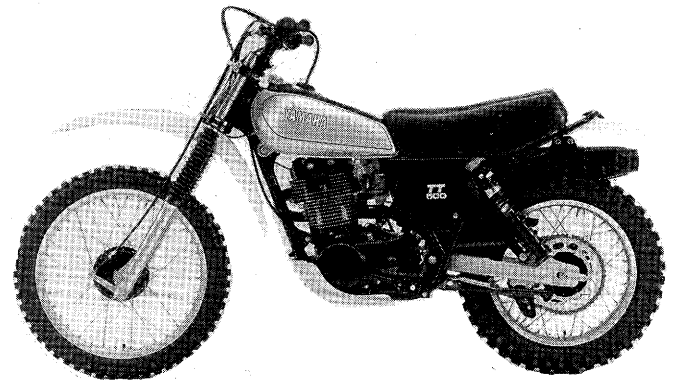
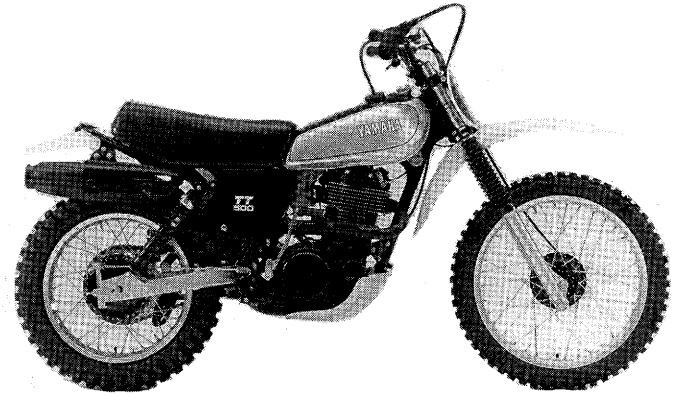

NOTICE

ALL PART NUMBERS CONTAINED IN THIS CATALOGUE ARE COMPRISED OF TEN DIGITS. WHEN ORDERING, PLEASE ADD TWO ZEROS TO THE END OF EACH PART NUMBER REQUIRED TO CONVERT THE TEN DIGITS INTO THE NEW TWELVE DIGIT NUMBERS.

FOREWORD

This Parts Catalogue is related to the parts in use for the Yamaha TT500G (2YO)
 When you are ordering replacement parts for the TT500G (2YO), refer to this Parts Catalogue and quote both part numbers and part names correctly.

1. Modifications or additions which have been made after issue of the Parts Catalogue will be announced in the Yamaha Parts News.
 It is advisable that according to the Yamaha Parts News you make necessary corrections to the Parts Catalogue on hand to keep it up-to-date.

2. Abbreviations

The following abbreviations are used in this Parts Catalogue.

- U.R. Use size (thickness) and/or number as required.
- U.N. Use as many as you need.
- A.P. Alternate Parts
- L.M. Local Made
- F# Frame No. (Applicable machine No.)

3. The parts marked with (*) in the parts number column of this Catalogue are not supplied with by Yamaha, those have to be found locally.
4. Parts, which are to be supplied in the form of assemblies, are listed with an indentation of one letter's space, and a dot (.) is put against the name of each part.

EXAMPLE CARBURETOR ASS'Y
 . JET, pilot
 . NOZZLE, main

5. Indication of No. of constituent parts for assembly

The numeral appearing to the right of each constituent part under the description indicates the quantity of such parts for each individual assembly unit.

EXAMPLE

Part No.	Description	Q'ty	Remarks
2F5-83310-60	FRONT FLASHER LIGHT ASS'Y	2	
115-83311-60	. BULB (6V-18W)	1	
1M1-83309-60	. REFLECTOR	1	

6. Exhaust section parts comply with all Florida laws and regulations requiring testing certification of exhaust system replacement parts.

7. Initial Serial No. and Color Code

(A) Frame Serial No.	1T1-230101 and following
(B) Engine Serial No.	1T1-230101 and following

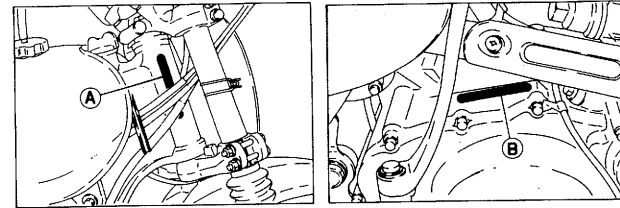

Color Code	Color Name	Abbreviate
6G	NEW YAMAHA BLACK	NYB

8. Applicable colors of graphics are represented in the "Remarks" column by the letter(s) appropriately picked out of the full word(s) showing such colors.

EXAMPLE

Part No.	Description	Q'ty	Remarks
2N4-24110-00-X5	FUEL TANK COMP.	1	MAXIM RED
3J1-24240-10	. GRAPHIC, fuel tank set	1	for MXR

CONTENTS

ENGINE

Fig. 1	CYLINDER HEAD	1
Fig. 2	CYLINDER	2
Fig. 3	CRANKSHAFT · PISTON	3
Fig. 4	VALVE	4
Fig. 5	CAMSHAFT · CHAIN	5
Fig. 6	OIL PUMP · OIL CLEANER	6
Fig. 7	CARBURETOR	8
Fig. 8	INTAKE	11
Fig. 9	EXHAUST	12
Fig. 10	CRANKCASE	14
Fig. 11	CRANKCASE COVER	15
Fig. 12	FLY WHEEL MAGNETO	16
Fig. 13	KICK STARTER	17
Fig. 14	CLUTCH	19
Fig. 15	TRANSMISSION	20
Fig. 16	SHIFT COM · FORK	22
Fig. 17	SHIFT SHAFT · PEDAL	23

CHASSIS

Fig. 18	FRAME	24
Fig. 19	FRONT FENDER · REAR FENDER	26
Fig. 20	REAR ARM · SUSPENSION	27
Fig. 21	FRONT FORK	29
Fig. 22	STEERING	31
Fig. 23	FUEL TANK	32
Fig. 24	SEAT	33
Fig. 25	FRONT WHEEL	34
Fig. 26	REAR WHEEL	35
Fig. 27	HANDLEBAR · CABLE	37

Fig. 28	STAND · FOOTREST	38
Fig. 29	ELECTRICAL 1	40
Fig. 30	HANDLE SWITCH · LEVER	41

ALTERNATE PARTS

Fig. 31	TACHOMETER	44
Fig. 32	HEADLIGHT, TAILLIGHT	45

INDEX

NUMERICAL INDEX

PARTS NAME INDEX

FIG. 1 CYLINDER HEAD

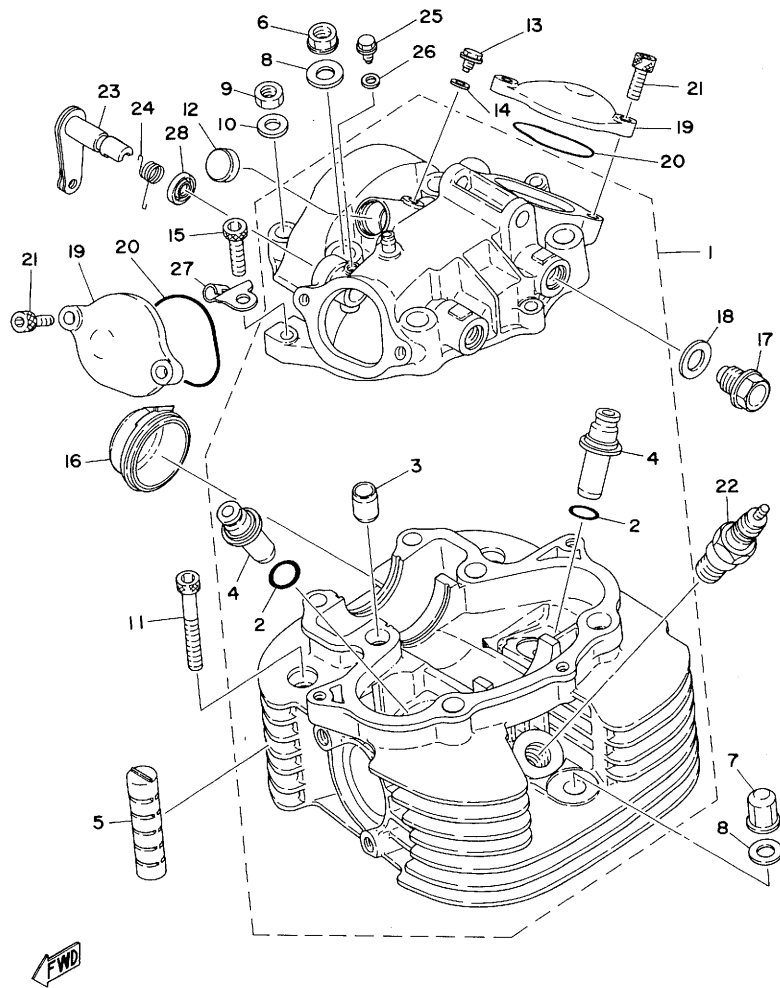

REF. NO.	PART NO.	DESCRIPTION	Q'TY	REMARKS
1	2Y0-11110-00-R4	CYLINDER HEAD ASSY	1	black
2	93210-14299	O-RING	2	
3	91830-24016	PIN, dowel	2	
4	583-11133-11	GUIDE, intake valve (1ST O/S)	2	
5	583-11127-00	ABSORBER 3	2	
6	90179-10279	NUT	4	
7	90179-10277	NUT	1	
8	90201-10124	WASHER, Plate	5	
9	95303-08600	NUT	2	
10	90201-08649	WASHER, Plate	2	
11	91316-06055	BOLT	2	
12	90338-18067	PLUG	1	
13	90109-06418	BOLT	1	
14	90430-06014	GASKET	1	
15	91316-06025	BOLT	3	
16	1T1-11197-00	PLUG, viewer	1	
17	90340-14038	PLUG, straight screw	2	
18	90430-14043	GASKET	2	
19	583-11186-00-R4	COVER, cylinder head side 2	2	black
20	93210-49296	O-RING	2	
21	91316-06018	BOLT	4	
22	94701-00117	PLUG, sPark (NGK BP-7ES)	1	
23	583-12288-00	CAM, decomp.	1	
24	90508-16303	SPRING, torsion	1	
25	90109-06418	BOLT	1	
26	90430-06014	GASKET	1	
27	583-12283-00	BRACKET, decomp.	1	
28	93104-12054	OIL SEAL	1	

FIG. 2 CYLINDER

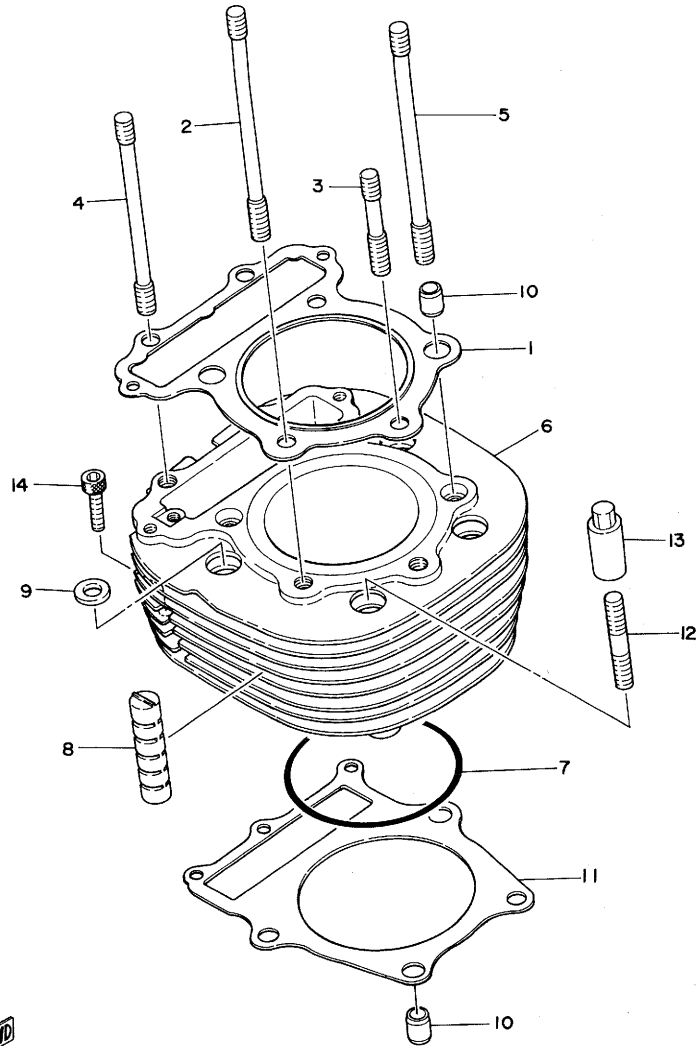

REF. NO.	PART NO.	DESCRIPTION	Q'TY	REMARKS
1	583-11181-01	GASKET, cylinder head 1	1	
2	90116-10222	BOLT, stud	2	
3	90116-10223	BOLT, stud	1	
4	90116-08190	BOLT, stud	2	
5	90116-10225	BOLT, stud	2	
6	583-11310-00	CYLINDER	1	
7	93210-92295	O-RING	1	
8	583-11127-00	ABSORBER 3	2	
9	90201-10590	WASHER, Plate	4	
10	91830-24016	PIN, dowel	4	
11	583-11351-00	GASKET, cylinder	1	
12	90116-10087	BOLT, stud	4	
13	90179-10201	NUT	4	
14	91316-06030	BOLT	3	

FWD

FIG. 3 CRANKSHAFT.PISTON

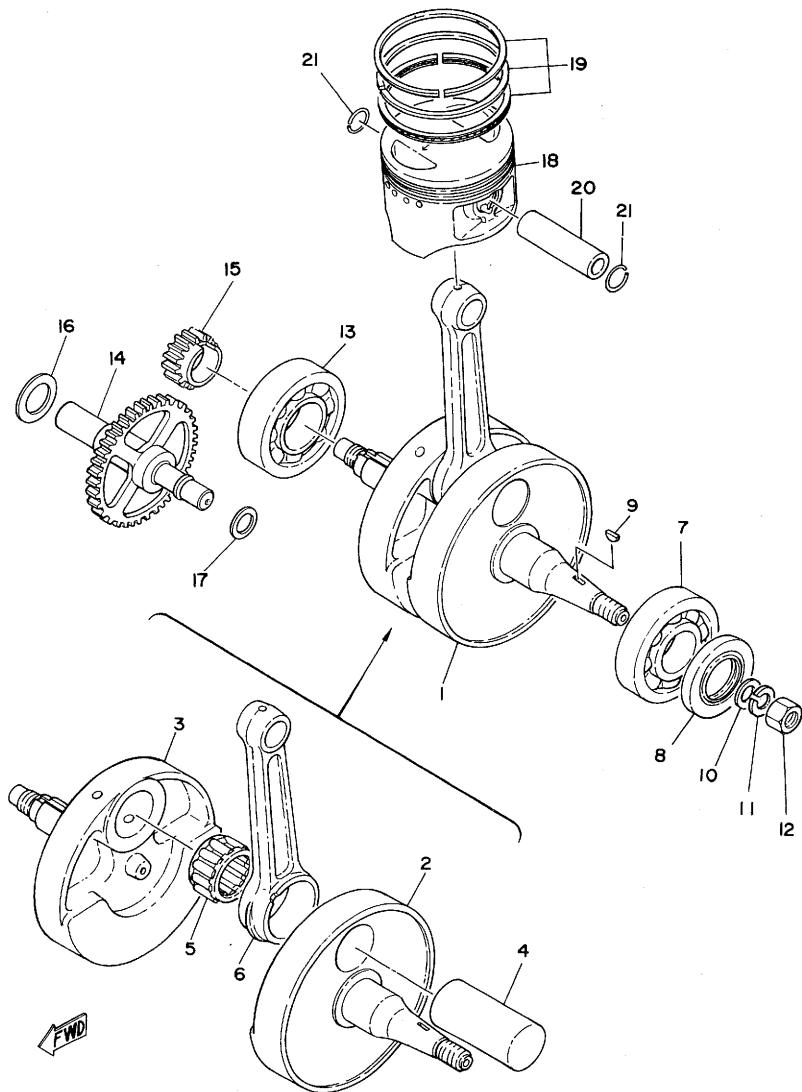

REF. NO.	PART NO.	DESCRIPTION	Q'TY	REMARKS
1	583-11400-00	CRANKSHAFT ASSY	1	
2	583-11412-00	•CRANK 1	1	
3	583-11422-00	•CRANK 2	1	
4	583-11681-00	•PIN, crank 1	1	
5	93310-635A5	•BEARING, cylindrical	1	
6	583-11651-00	•ROD, connecting	1	
7	93306-30616	BEARING (B6306)	1	
8	93102-30145	OIL SEAL	1	
9	90280-05013	KEY, woodruff	1	
10	90201-12593	WASHER, Plate	1	
11	92901-12100	WASHER, sPring	1	
12	90170-12067	NUT	1	
13	93306-30702	BEARING (B6307)	1	
14	583-11150-00	BREAKER SHAFT ASSY	1	
15	583-11536-00	GEAR, drive (21T)	1	
16	90201-15234	WASHER, Plate	1	
17	90201-09572	WASHER, Plate	1	
18	583-11631-02-95	PISTON (STD)	1	UR
	583-11631-02-96	PISTON (STD)	1	UR
	583-11635-02	PISTON (1ST O/S 0.25MM)	1	AP
	583-11636-02	PISTON (2ND O/S 0.50MM)	1	AP
	583-11637-02	PISTON (3RD O/S 0.75MM)	1	AP
	583-11638-02	PISTON (4TH O/S 1.00MM)	1	AP
19	583-11610-01	PISTON RING SET (STD)	1	AP STD
	583-11610-11	PISTON RING SET (1ST O/S)	1	AP
	583-11610-21	PISTON RING SET (2ND O/S)	1	AP
	583-11610-31	PISTON RING SET (3RD O/S)	1	AP
	583-11610-41	PISTON RING SET (4TH O/S)	1	AP
20	583-11633-00.	PIN, Piston	1	
21	93450-22027	CIRCLIP	2	

FIG. 4 VALVE

REF. NO.	PART NO.	DESCRIPTION	Q'TY	REMARKS
1	2J2-12111-00	VALVE, intake	1	
2	583-12121-00	VALVE, exhaust	1	
3	90501-31454	SPRING, compression	2	
4	90501-44455	SPRING, compression	2	
5	256-12116-01	SEAT, valve spring	2	
6	341-12119-02	SEAL, valve stem	2	
7	256-12117-01	RETAINER, valve spring	2	
8	341-12118-00	COTTER, valve	4	
9	583-12151-00	ARM, valve rocker	2	
10	583-12156-01	SHAFT, rocker	2	
11	583-12159-00	SCREW, valve adjusting	2	
12	90170-08173	NUT	2	

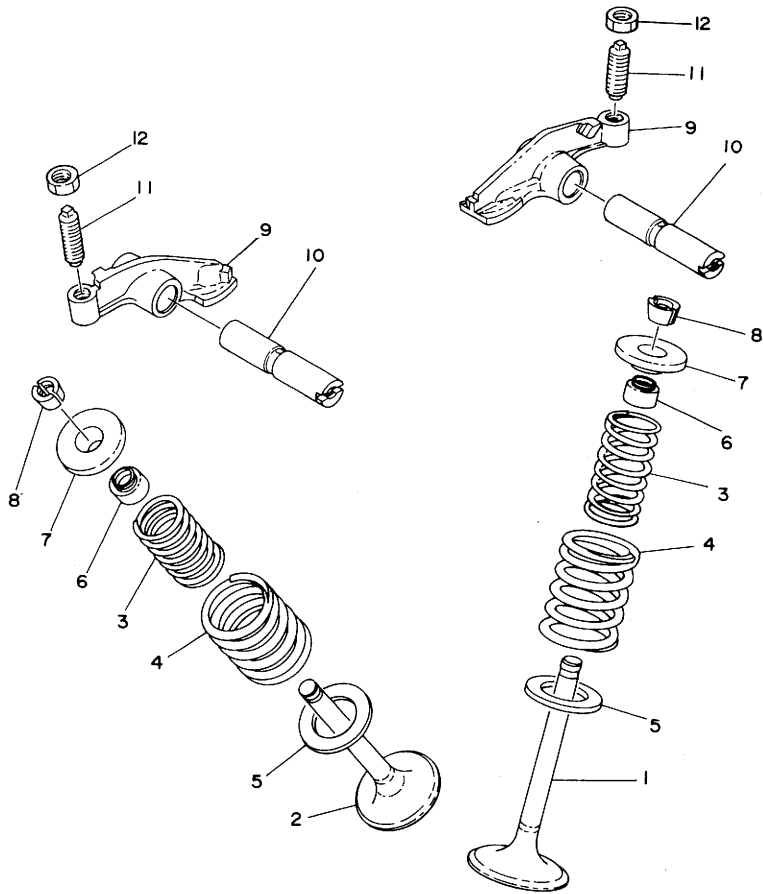

FWD

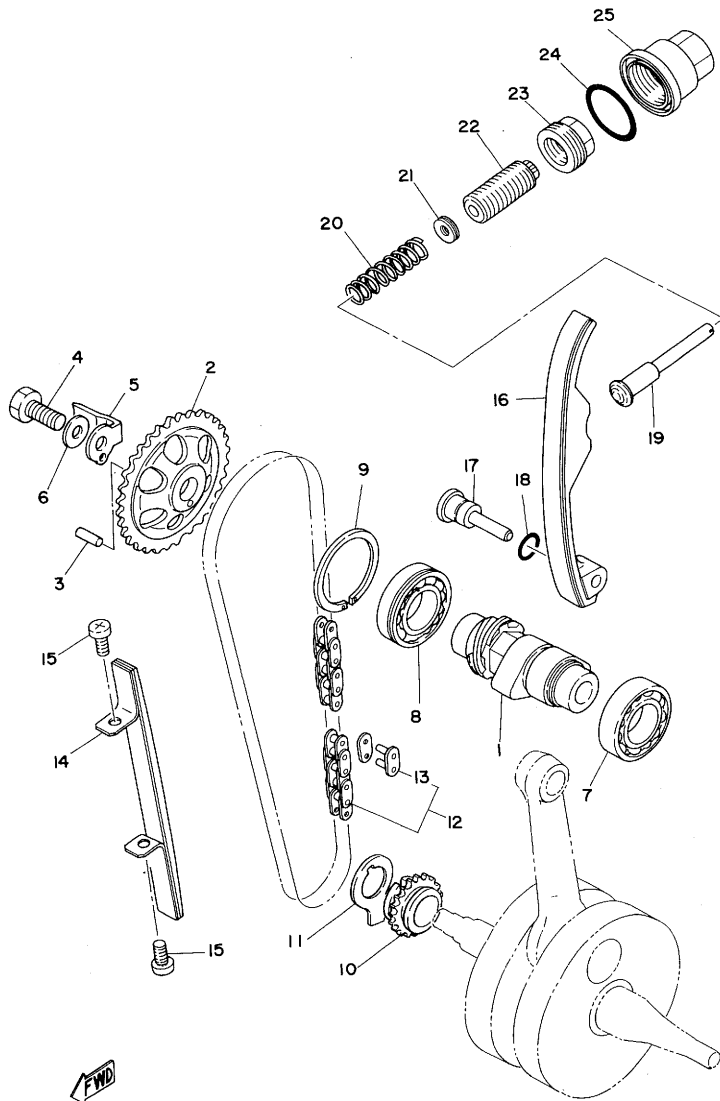
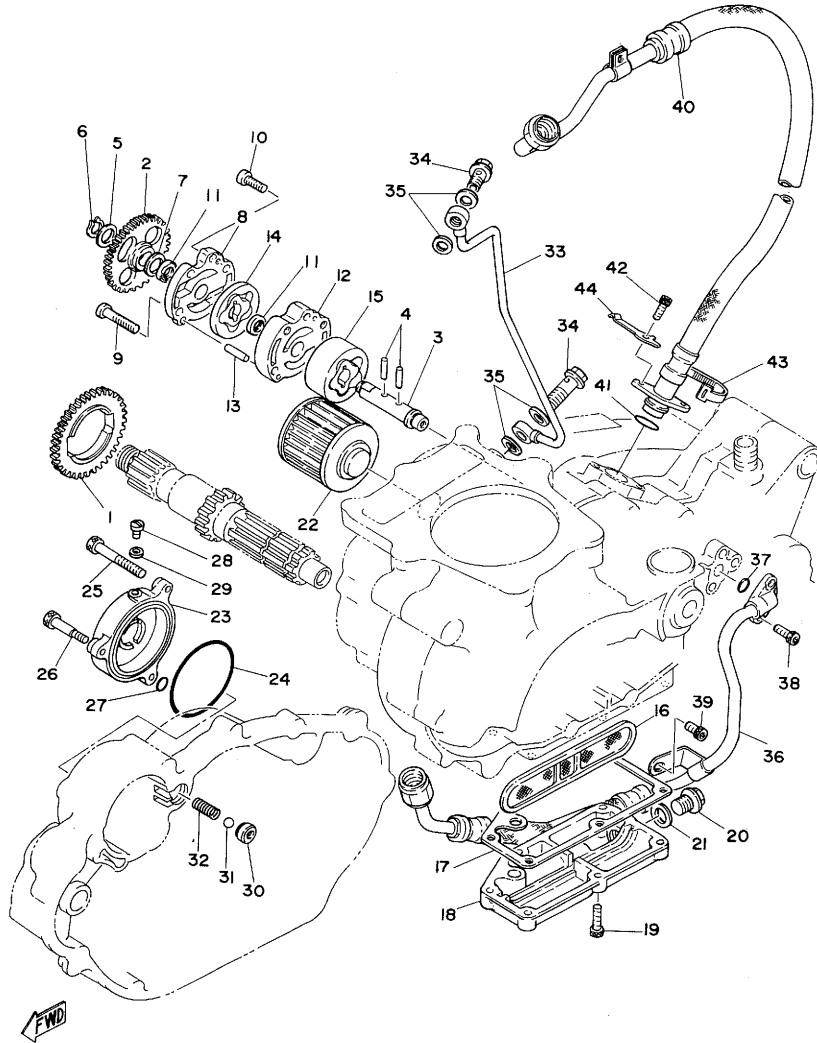

FIG. 5 CAMSHAFT.CHAIN

REF. NO.	PART NO.	DESCRIPTION	Q'TY	REMARKS
1	583-12171-01	CAMSHAFT	1	
2	583-12176-00	SPROCKET, cam chain (34T)	1	
3	93604-16092	PIN, dowel	1	
4	90101-10303	BOLT	1	
5	1T1-12279-00	PLATE	1	
6	90201-10591	WASHER, Plate	1	
7	93306-00502	BEARING (B6005)	1	
8	93306-00506	BEARING (B6005)	1	
9	93440-47044	CIRCLIP	1	
10	583-11549-00	SPROCKET, cam chain (17T)	1	
11	583-11533-00	PLATE, cam chain sProcket	1	
12	94500-02106	CHAIN (BF05M-106L)	1	
13	94600-02001	.JOINT, chain	1	
14	583-12231-00	GUIDE, stopPer 1	1	
15	92501-06015	SCREW, Pan head	2	
16	341-12241-03	GUIDE, stopPer 2	1	
17	583-12247-00	SHAFT, tensioner	1	
18	93210-12152	O-RING	1	
19	583-12217-00	ROD, chain tensioner	1	
20	90501-14095	SPRING, comPression	1	
21	2H0-12232-00	DAMPER	1	
22	90149-18100	SCREW	1	
23	90179-18199	NUT	1	
24	93210-32172	O-RING	1	
25	583-12212-00	CAP, chain tensioner	1	

FIG. 6 OIL PUMP.OIL CLEANER



REF. NO.	PART NO.	DESCRIPTION	Q'TY	REMARKS
1	583-13324-00	GEAR, drive (42T)	1	
2	583-13325-00	GEAR, Pump driven (41T)	1	
3	583-13314-00	SHAFT, Pump	1	
4	93603-17070	PIN, dowel	2	
5	90201-10119	WASHER, Plate	1	
6	93410-10025	CIRCLIP	1	
7	90201-12166	WASHER, Plate	1	
8	583-13316-02	COVER, Pump	1	
9	92501-06030	SCREW, Pan head	3	
10	92501-06018	SCREW, Pan head	2	
11	93104-11038	OIL SEAL	2	
12	583-13336-02	HOUSING, rotor	1	
13	93604-22050	PIN, dowel	2	
14	583-13310-01	ROTOR ASSY 1	1	
15	583-13320-00	ROTOR ASSY 2	1	
16	583-13411-00	STRAINER, oil	1	
17	583-13414-00	GASKET, strainer cover	1	
18	583-13417-01	COVER, strainer	1	
19	91316-06020	BOLT	6	
20	90340-14009	PLUG, straight screw	1	
21	214-11198-01	GASKET	1	
22	2H0-13440-90	ELEMENT ASSY, oil cleaner	1	
23	583-13447-00	COVER, oil element	1	
24	93210-64297	O-RING	1	
25	91316-06060	BOLT	2	
26	90109-06511	BOLT	1	
27	93210-07135	O-RING	1	
28	90149-05110	SCREW	1	
29	90430-05126	GASKET	1	
30	583-13113-00	SEAT, check ball	1	

FIG. 6 OIL PUMP.OIL CLEANER

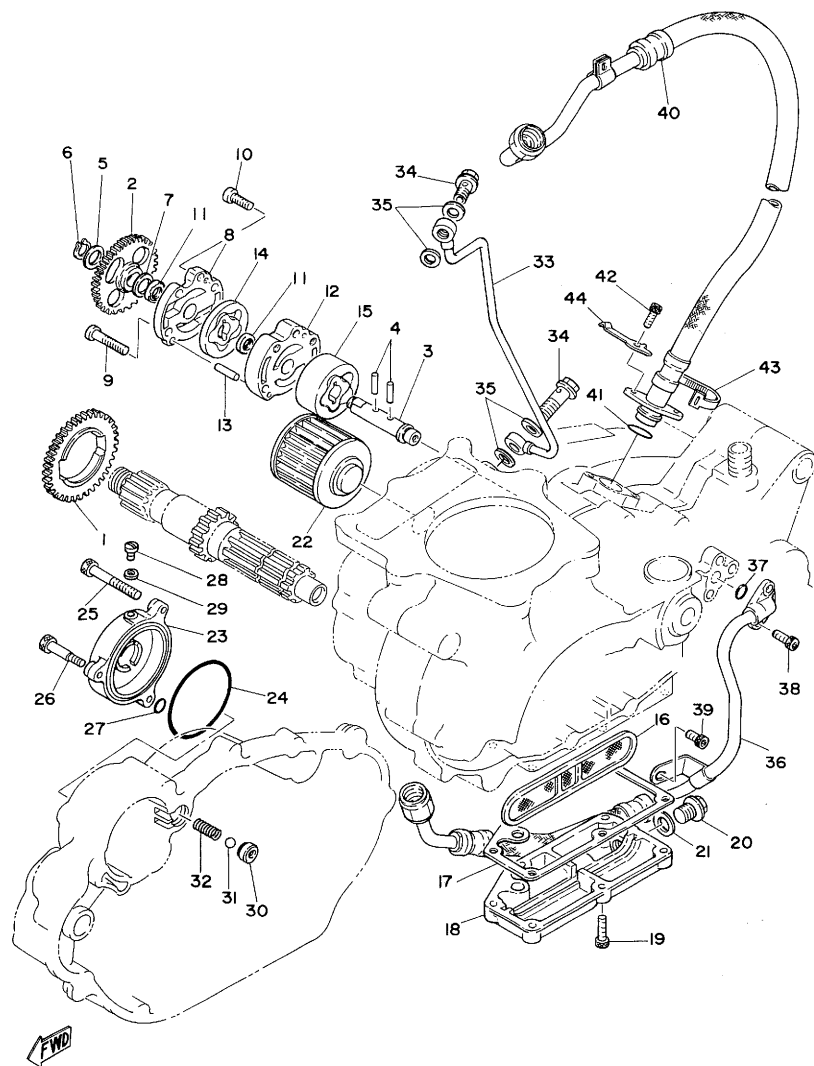

REF. NO.	PART NO.	DESCRIPTION	Q'TY	REMARKS
31	93503-08007	BALL	1	
32	90501-05378	SPRING, compression	1	
33	583-13161-01	PIPE, delivery 1	1	
34	90401-08038	BOLT, union	2	
35	90430-08119	GASKET	4	
36	583-13464-00	HOSE, oil 1	1	
37	93210-10197	O-RING	1	
38	91316-06015	BOLT	2	
39	91316-06012	BOLT	1	
40	583-13465-02	HOSE, oil 2	1	
41	93210-15171	O-RING	1	
42	91316-06015	BOLT	2	
43	437-83936-00	BAND, switch cord	1	
44	90465-06077	CLAMP	1	

FIG. 7 CARBURETOR

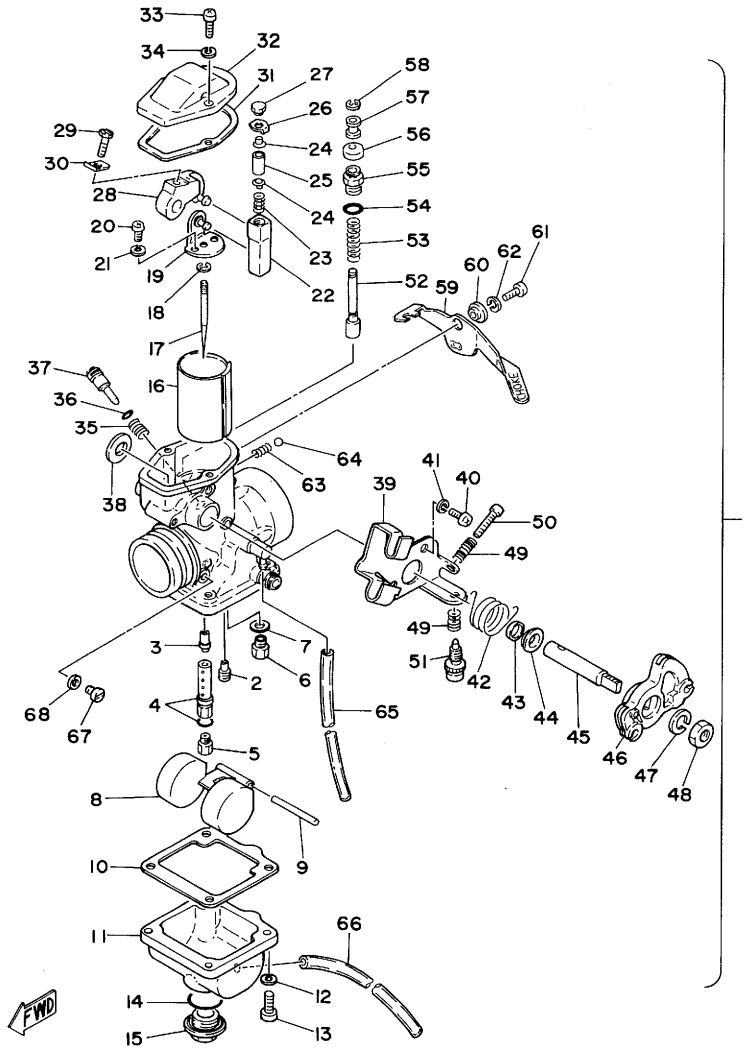

REF. NO.	PART NO.	DESCRIPTION	Q'TY	REMARKS
1	2Y0-14101-01	CARBURETOR ASSY 1	1	
2	193-14142-30	•JET, Pilot (#30.0)	1	
3	583-14141-52	•NOZZLE, main	1	
4	583-14148-00	•PIPE	1	
5	137-14143-46	•JET, main (#230)	1	UR
	137-14143-48	•JET, main (#240)	1	UR
	137-14143-50	•JET, main (#250)	1	UR
6	168-14190-28	•NEEDLE VALVE ASSY	1	
7	214-14195-00	•WASHER, needle valve	1	
8	583-14185-00	•FLOAT	1	
9	127-14186-00	•PIN, float	1	
10	583-14184-00	•GASKET, float chamber	1	
11	2Y0-14181-00-12	•BODY, float chamber 1	1	
12	92901-06100	•WASHER, sPring	4	
13	92501-06015	•SCREW, Pan head	4	
14	558-14147-00	•O-RING	1	
15	2Y0-14115-00	•PLUG, screw	1	
16	583-14112-40	•VALVE, throttle 1	1	
17	1T1-14116-02	•NEEDLE	1	
18	164-14137-00	•CLIP	1	
19	583-14291-00	•BRACKET 1	1	
20	98501-04012	•SCREW, Pan head	2	
21	92901-04100	•WASHER, sPring	2	
22	583-14274-00	•CONNECTOR	1	
23	583-14933-00	•SPRING, diaPhraGm	1	
24	583-14558-00	•PIN	2	
25	583-14386-00	•PIN	1	
26	583-14951-00	•WASHER	1	
27	583-14216-00	•SCREW	1	
28	583-14292-00	•LEVER, throttle valve	1	

FIG. 7 CARBURETOR

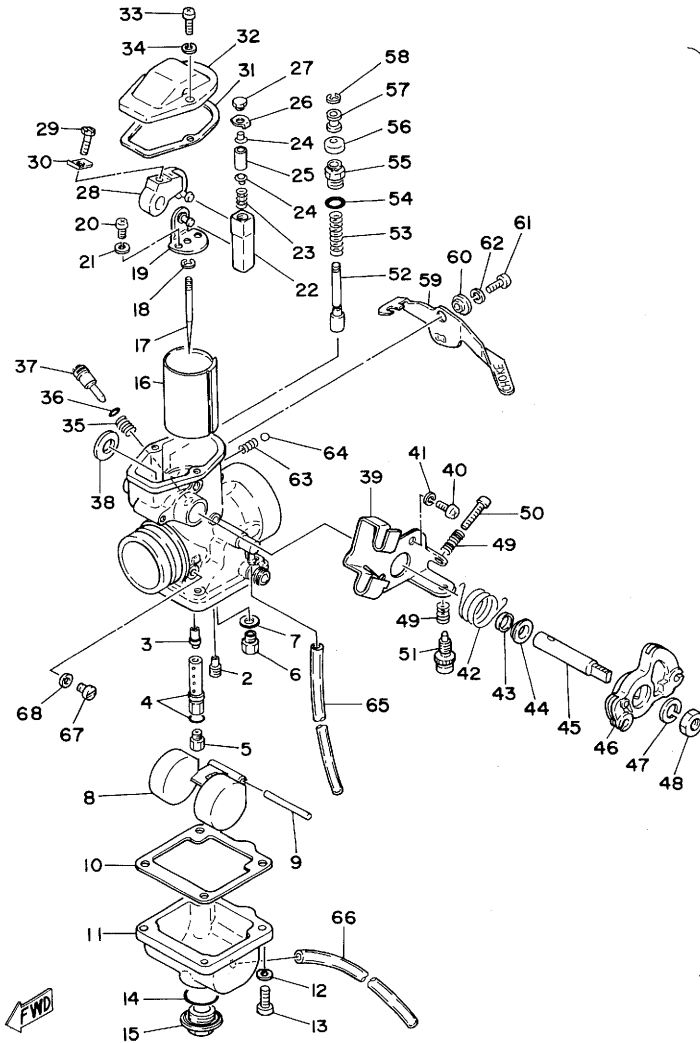

REF. NO.	PART NO.	DESCRIPTION	Q'TY	REMARKS
29	583-14592-00	.SCREW	1	
30	583-14597-00	.WASHER	1	
31	583-14536-00	.GASKET	1	
32	583-14158-00	.TOP, mixing chamber	1	
33	98501-04014	.SCREW, Pan head	2	
34	92901-04100	.WASHER, sPring	2	
35	127-14134-00	.SPRING, air adjusting	1	
36	354-14147-00	.O-RING	1	
37	525-14123-00	.SCREW, air adjusting	1	
38	583-14264-00	.SPACER	1	
39	2J2-14571-00	.BRACKET, throttle	1	
40	98501-05012	.SCREW, Pan head	2	
41	92901-05100	.WASHER, sPring	2	
42	583-14131-01	.SPRING, throttle valve	1	
43	583-14239-01	.SEAL	1	
44	583-14265-00	.WASHER	1	
45	583-14215-00	.SHAFT, throttle lever	1	
46	583-14573-00	.LEVER	1	
47	92901-08100	.WASHER, sPring	1	
48	812-14594-00	.NUT	1	
49	2J2-14133-00	.SPRING, throttle stop	2	
50	583-14245-01	.SCREW, guide	1	
51	2J2-14121-00	.SCREW, throttle stop	1	
52	583-14171-01	.PLUNGER, starter	1	
53	500-14135-00	.SPRING, PlunGer	1	
54	583-14562-00	.O-RING	1	
55	583-14174-00	.CAP, PlunGer	1	
56	802-14173-00	.COVER, PlunGer caP	1	
57	583-14918-00	.RING	1	
58	737-14137-00	.CLIP	1	

FIG. 7 CARBURETOR

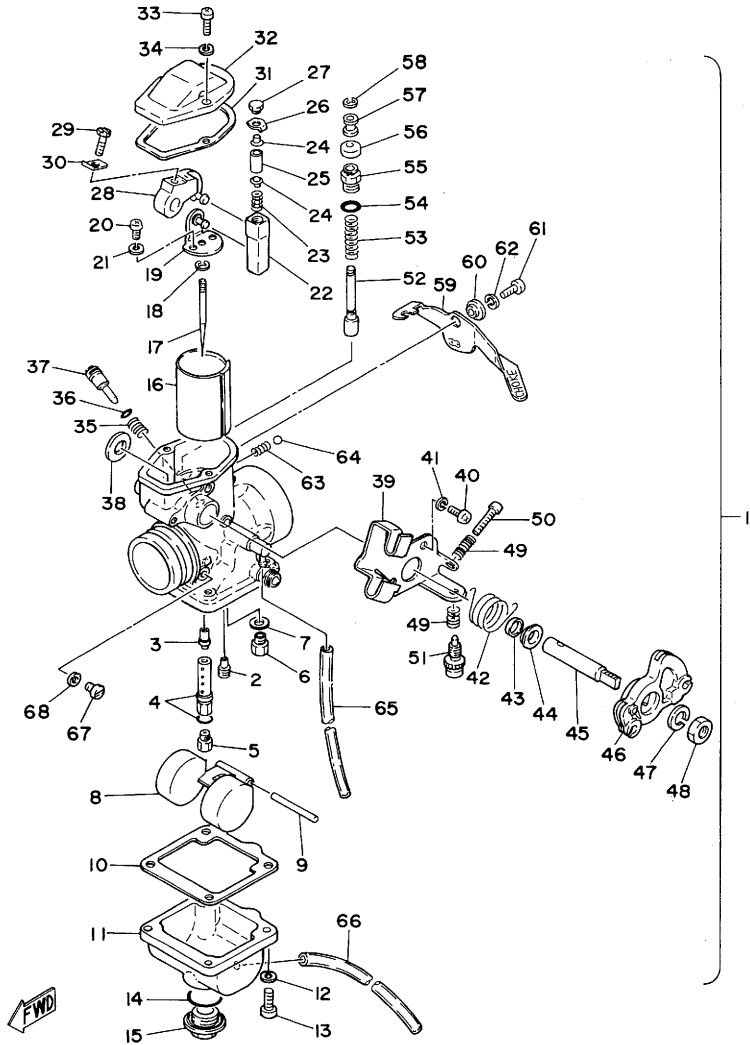

REF. NO.	PART NO.	DESCRIPTION	Q'TY	REMARKS
59	583-14175-01	•LEVER, starter	1	
60	583-14594-00	•COLLAR	1	
61	92501-06012	•SCREW, Pan head	1	
62	92901-06100	•WASHER, sPring	1	
63	583-14589-00	•SPRING	1	
64	93501-08001	•BALL	1	
65	583-14197-01	•PIPE	1	
66	432-14197-00	•PIPE	1	
67	341-14991-00	•SCREW	1	
68	584-14956-00	•WASHER	1	
69	214-14147-00	•O-RING	1	
70	2L1-14191-00	•SCREW	1	

FIG. 8 INTAKE

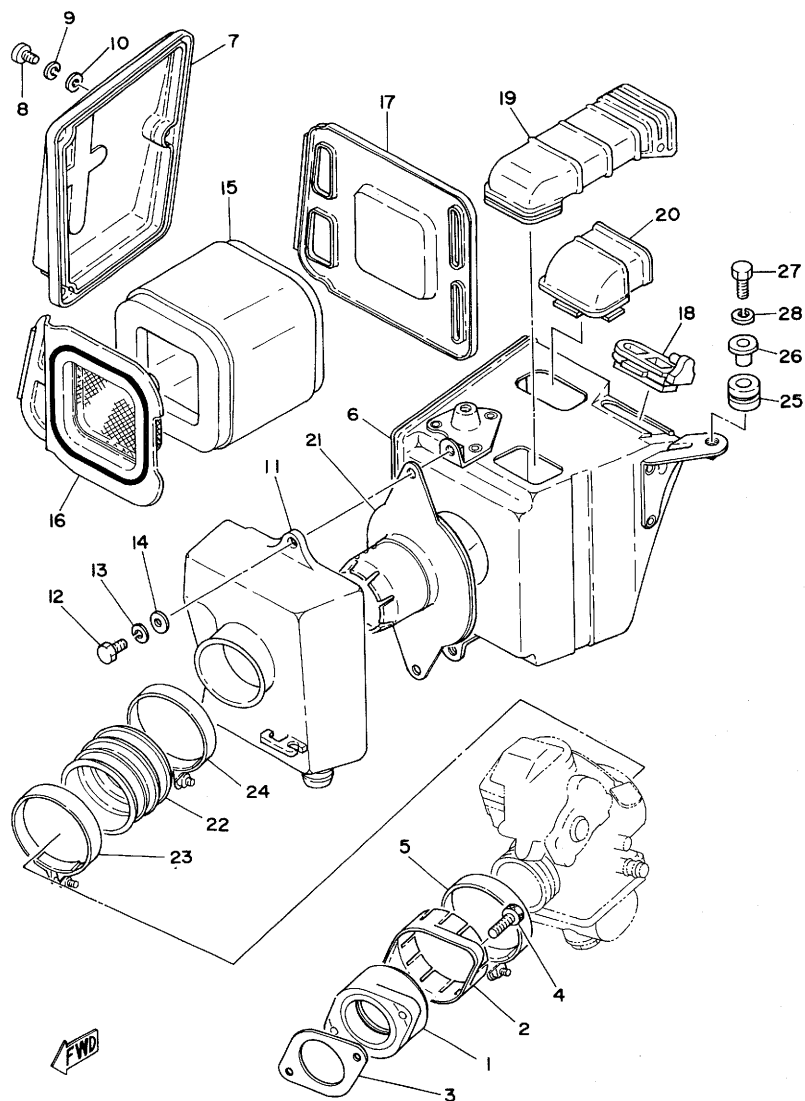

REF. NO.	PART NO.	DESCRIPTION	Q'TY	REMARKS
1	583-13565-01	JOINT, carburetor	1	
2	256-13564-00	COVER, manifold	1	
3	583-13556-01	GASKET, manifold	1	
4	91316-06025	BOLT	2	
5	90460-58015	CLAMP, hose	1	
6	583-14411-01	CASE, air cleaner 1	1	
7	583-14422-00	CAP, cleaner case 2	1	
8	98501-05012	SCREW, Pan head	3	
9	92901-05100	WASHER, sPring	3	
10	92901-05600	WASHER, Plate	3	
11	583-14421-00	CASE, air cleaner 2	1	
12	97301-06020	BOLT	2	
13	92901-06100	WASHER, sPring	2	
14	92901-06600	WASHER, Plate	2	
15	583-14451-00	ELEMENT, air cleaner	1	
16	583-14468-01	PLATE, element fitting	1	
17	583-14472-00	PLATE, element	1	
18	1T1-14437-00	DUCT	1	
19	583-14431-00	SILENCER, intake 1	1	
20	1T1-14441-00	SILENCER, intake 2	1	
21	583-14485-00	PIPE, joint	1	
22	583-14453-00	JOINT, air cleaner 1	1	
23	90460-58015	CLAMP, hose	1	
24	90460-61063	CLAMP, hose	1	
25	90480-14102	GROMMET	2	
26	90387-07391	COLLAR	2	
27	97301-06025	BOLT	2	
28	92901-06100	WASHER, sPring	2	

FIG. 9 EXHAUST

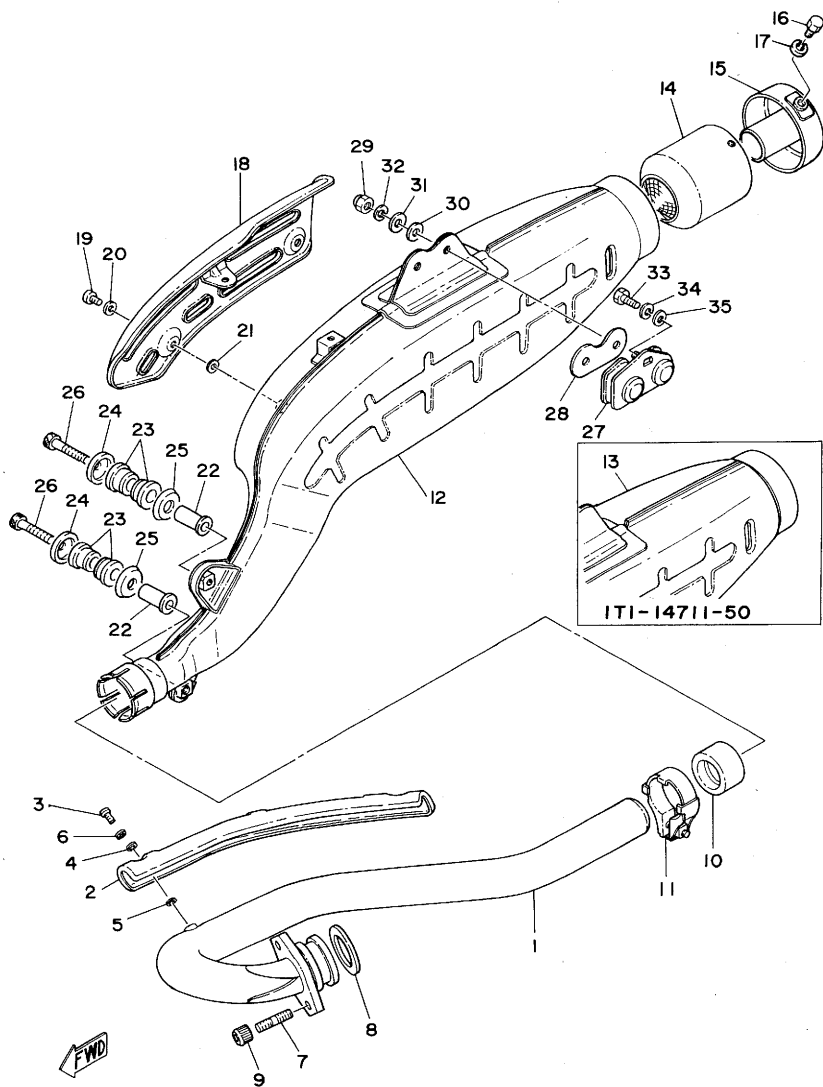

REF. NO.	PART NO.	DESCRIPTION	Q'TY	REMARKS
1	1T1-14611-02	PIPE, exhaust 1	1	
2	1T1-14628-00	PROTECTOR, exhaust Pipe	1	
3	98906-06010	SCREW, bind	2	
4	583-14766-00	WASHER, Protector	2	
5	1E6-14766-01	WASHER, Protector	2	
6	90206-06060	WASHER, wave	2	
7	95621-08615	BOLT, stud	2	
8	90430-38054	GASKET	1	
9	90179-08004	NUT	2	
10	1T1-14714-01	GASKET, muffler	1	
11	1T1-14788-00	BAND, silencer	1	
12	1T1-14711-32	MUFFLER 1	1	
13	1T1-14711-50	MUFFLER 1	1	
14	*	ARRESTER, sPark	1	LM
15	1T1-14752-01	PIPE, outlet	1	
16	97321-06010	BOLT	2	
17	92901-06100	WASHER, sPring	2	
18	1T1-14718-00	PROTECTOR, muffler 1	1	
19	98906-06010	SCREW, bind	3	
20	583-14766-00	WASHER, Protector	3	
21	1E6-14766-01	WASHER, Protector	3	
22	90387-08572	COLLAR	2	
23	1T1-14747-01	DAMPER, muffler	4	
24	90209-08162	WASHER	2	
25	90209-12163	WASHER	2	
26	90110-08018	BOLT, hexagon socket head	2	
27	1T1-14791-01	STAY, muffler	1	
28	1T1-14755-01	GASKET, silencer	1	
29	95601-08100	NUT, u	2	
30	90202-08103	WASHER, Plate	2	

FIG. 9 EXHAUST

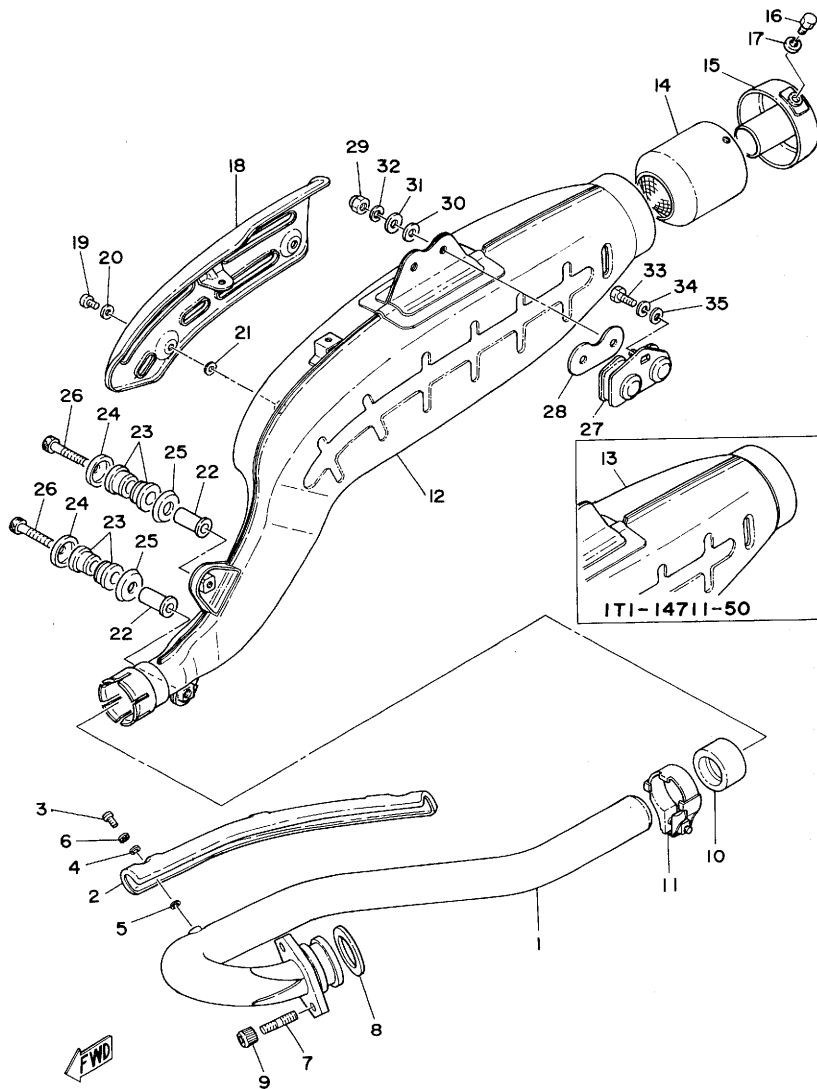

REF. NO.	PART NO.	DESCRIPTION	Q'TY	REMARKS
31	90201-08326	WASHER, Plate	2	
32	92901-08100	WASHER, sPring	2	
33	97321-08020	BOLT	1	
34	92901-08100	WASHER, sPring	1	
35	90201-08649	WASHER, Plate	1	

FIG. 10 CRANKCASE

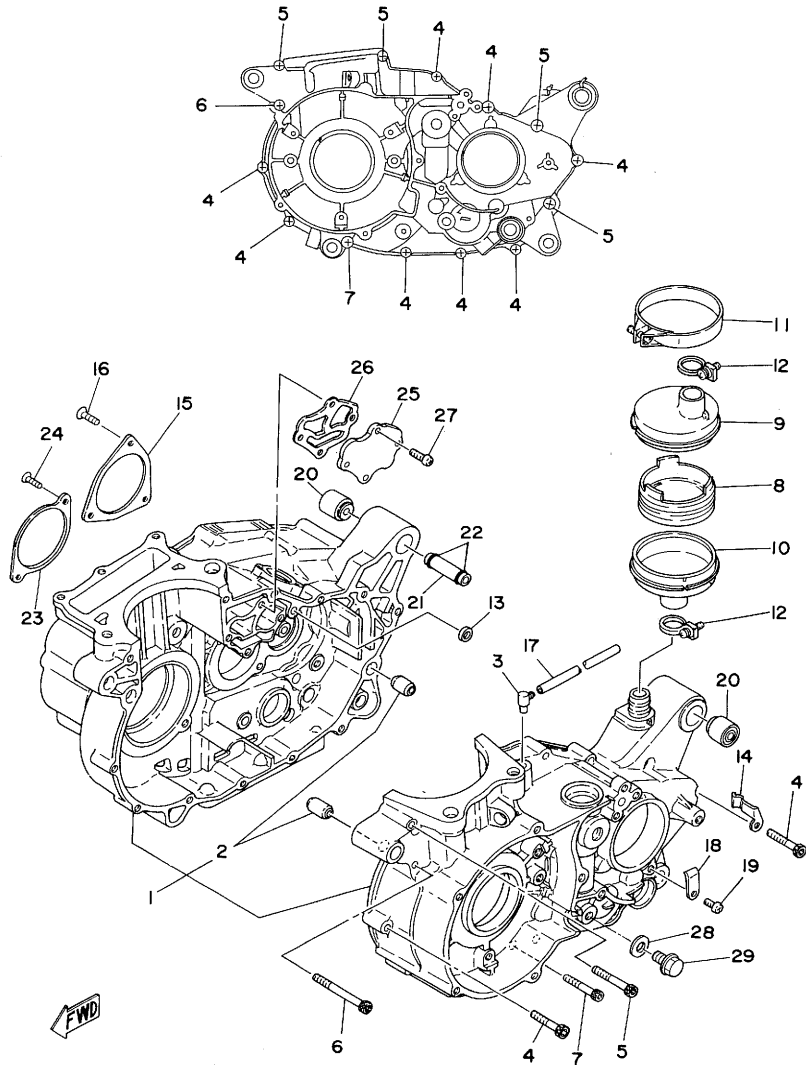

REF. NO.	PART NO.	DESCRIPTION	Q'TY	REMARKS
1	2Y0-15100-00	CRANKCASE ASSY	1	
2	91810-05016	.PIN, dowel	2	
3	583-15371-00	BREATHER	1	
4	91316-06035	BOLT	8	
5	91316-06045	BOLT	4	
6	91316-06065	BOLT	1	
7	91316-06055	BOLT	1	
8	583-15358-00	SEPARATOR, oil	1	
9	583-15346-00	BREATHER 1	1	
10	583-15347-00	BREATHER 2	1	
11	90460-71017	CLAMP, hose	1	
12	90460-22083	CLAMP, hose	2	
13	90430-09121	GASKET	1	
14	90465-05084	CLAMP	1	
15	363-15381-00	PLATE, bearing cover	1	
16	98701-05012	SCREW, flat head	3	
17	90445-07039	HOSE	1	
18	90465-05075	CLAMP	1	
19	92501-06012	SCREW, Pan head	1	
20	583-15316-00	DAMPER, engine mount 1	2	
21	583-15317-01	SPACER, engine mount	1	
22	93210-12095	O-RING	2	
23	583-15383-00	PLATE, bearing cover	1	
24	92701-06015	SCREW, flat head	2	
25	583-15426-00	COVER	1	
26	583-15466-00	GASKET 2	1	
27	92501-06018	SCREW, Pan head	4	
28	90430-10148	GASKET	1	
29	90340-10003	PLUG, straight screw	1	

FIG. 11 CRANKCASE COVER

REF. NO.	PART NO.	DESCRIPTION	Q'TY	REMARKS
1	583-15411-00	COVER, crankcase 1	1	
2	583-15451-00	GASKET, crankcase cover	1	
3	91316-06025	BOLT	4	
4	91316-06035	BOLT	1	
5	583-15421-00	COVER, crankcase 2	1	
6	91316-06035	BOLT	3	
7	583-15431-02-98	COVER, crankcase 3	1	low gloss black
8	93101-14089	OIL SEAL	1	
9	93420-25002	CIRCLIP	1	
10	93102-15147	OIL SEAL	1	
11	583-15462-00	GASKET, crankcase cover 3	1	
12	583-15425-00	COVER, Generator 2	1	
13	93210-35173	O-RING	1	
14	91316-06030	BOLT	8	
15	91316-06040	BOLT	2	
16	91830-22016	PIN, dowel	2	
17	583-15417-00	COVER, caP	1	
18	583-15457-00	GASKET	1	
19	91316-06025	BOLT	2	
20	90430-10027	GASKET	1	
21	90340-10003	PLUG, straight screw	1	
22	90465-08076	CLAMP	1	

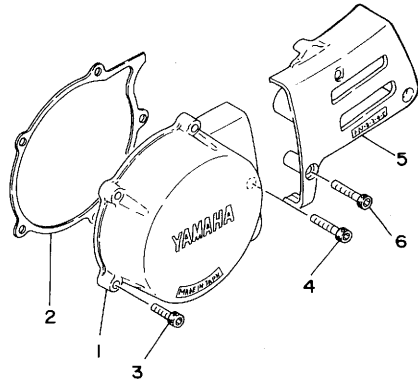
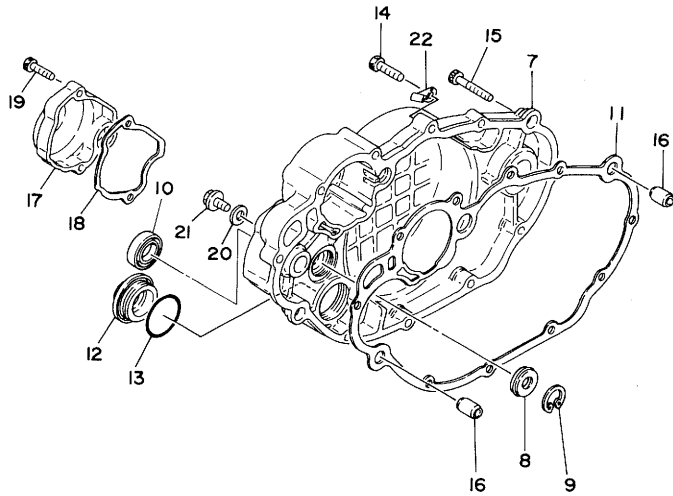
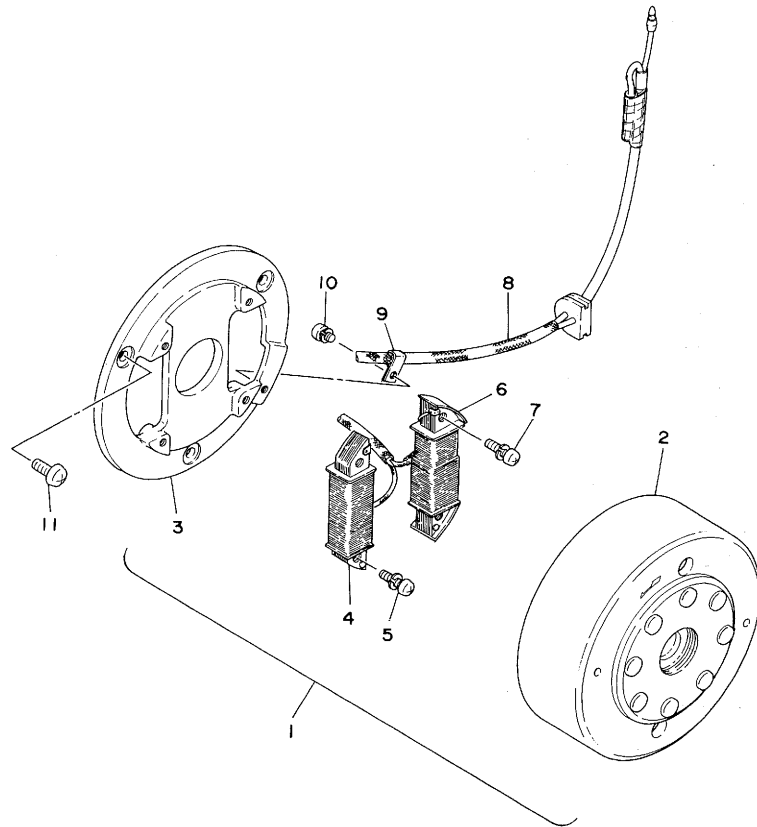
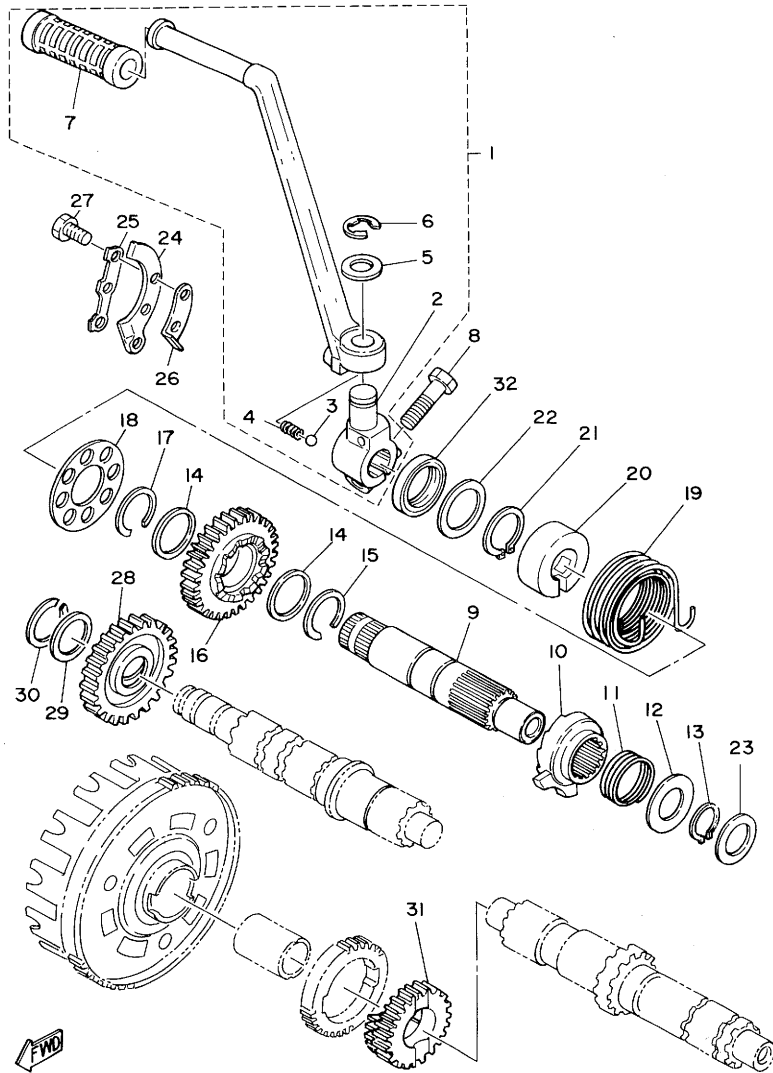

FIG. 12 FLY WHEEL MAGNETO



REF. NO.	PART NO.	DESCRIPTION	Q'TY	REMARKS
1	583-81300-50	FLYWHEEL MAGNETO ASSY	1	
2	583-81350-50	•ROTOR ASSY	1	
3	583-81309-50	•BASE, magneto	1	
4	583-81311-50	•COIL, ignition 1	1	
5	583-81345-50	•SCREW, Pan head	2	
6	583-81313-50	•COIL, lighting 1	1	
7	583-81345-50	•SCREW, Pan head	2	
8	583-81315-50	•LEAD WIRE ASSY	1	
9	583-81328-50	•CLAMP	1	
10	583-81346-50	•SCREW, Pan head	1	
11	92502-06016	SCREW, Pan head	3	

FIG. 13 KICK STARTER



REF. NO.	PART NO.	DESCRIPTION	Q'TY	REMARKS
1	1T1-15620-00	KICK CRANK ASSY	1	
2	583-15621-00	•BOSS, kick crank	1	
3	93507-32009	•BALL	1	
4	90501-12081	•SPRING, comPression	1	
5	90201-15234	•WASHER, Plate	1	
6	93430-10016	•CIRCLIP	1	
7	1T1-15618-00	•COVER, kick lever	1	
8	97321-08030	BOLT	1	
9	583-15661-00	AXLE, kick	1	
10	583-15671-00	WHEEL, ratchet	1	
11	90501-23143	SPRING, comPression	1	
12	363-15676-00	COVER, sPring	1	
13	93410-19015	CIRCLIP	1	
14	90201-25287	WASHER, Plate	2	
15	93440-25020	CIRCLIP	1	
16	583-15641-00	GEAR, kick (29T)	1	
17	93440-25019	CIRCLIP	1	
18	583-15676-00	COVER, sPring	1	
19	90508-32280	SPRING, torsion	1	
20	90560-25154	SPACER	1	
21	93410-25010	CIRCLIP	1	
22	90201-25290	WASHER, Plate	1	
23	90201-20278	WASHER, Plate	1	
24	583-15674-00	GUIDE, ratchet wheel	1	
25	363-15686-00	WASHER, lock	1	
26	434-15668-00	STOPPER	1	
27	97321-06016	BOLT	3	
28	583-15651-00	GEAR, sProcket idle (27T)	1	
29	90201-17255	WASHER, Plate	1	
30	93410-17008	CIRCLIP	1	

FIG. 13 KICK STARTER

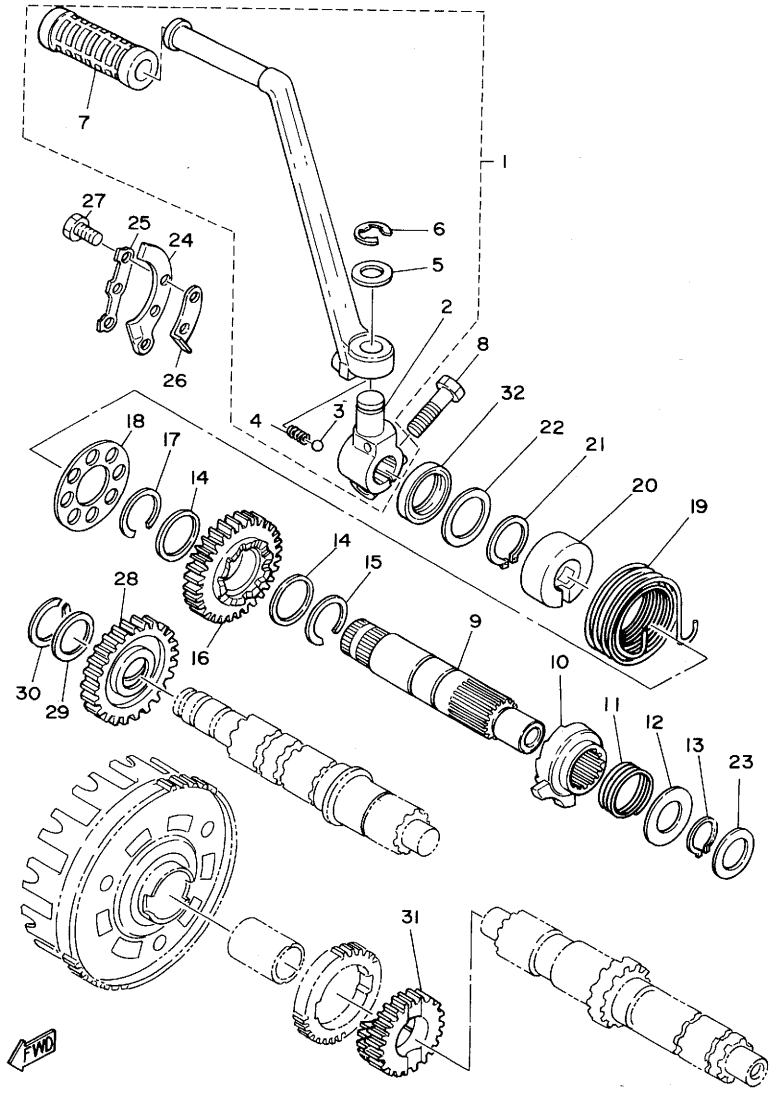

REF. NO.	PART NO.	DESCRIPTION	Q'TY	REMARKS
31	583-15631-00	GEAR, kick Pinion (19T)	1	
32	93102-25064	OIL SEAL	1	

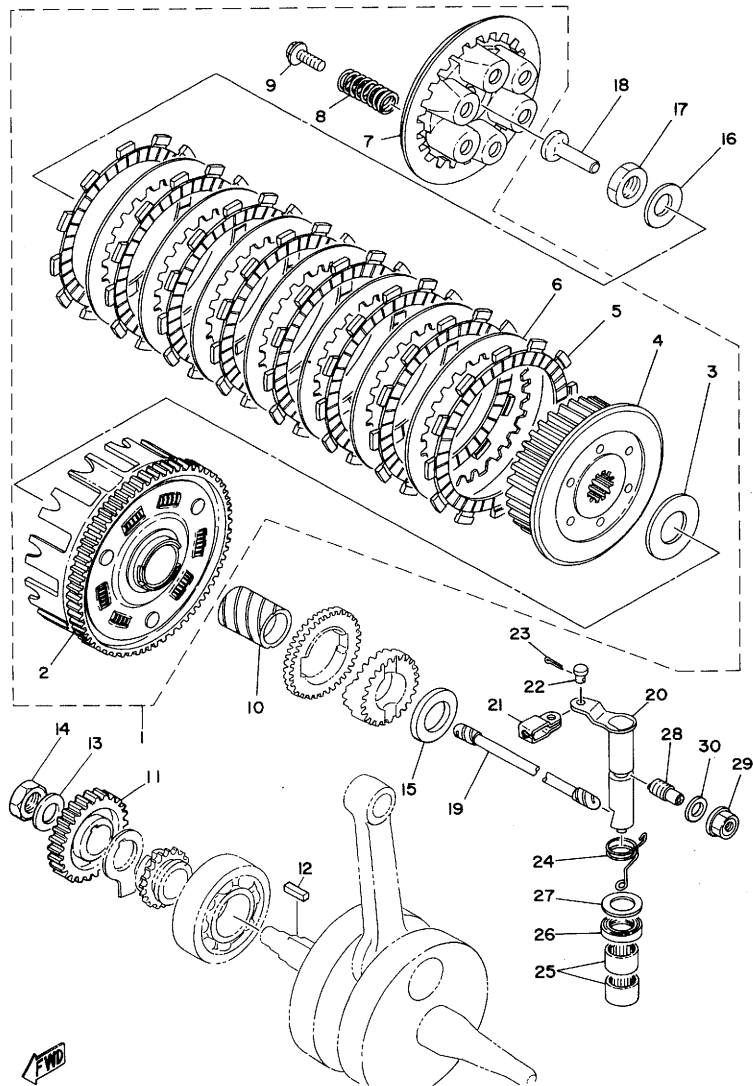
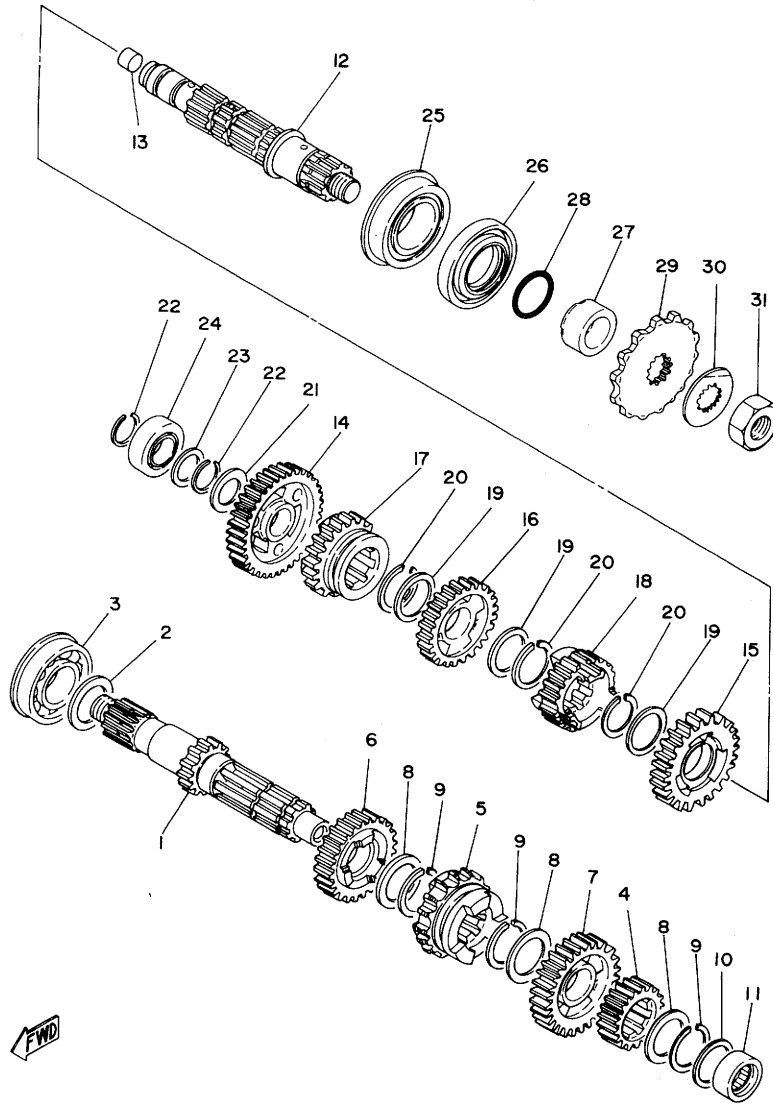

FIG. 14 CLUTCH

REF. NO.	PART NO.	DESCRIPTION	Q'TY	REMARKS
1	583-16301-00	CLUTCH ASSY	1	
2	583-16150-00	•PRIMARY DRIVEN GEAR COMP.(77T	1	
3	170-16164-00	•PLATE, thrust 2	1	
4	583-16371-00	•BOSS, clutch	1	
5	583-16321-00	•PLATE, friction	8	
6	360-16325-00	•PLATE, clutch 2	7	
7	498-16351-00	•PLATE, Pressure 1	1	
8	90501-23391	•SPRING, compression	6	
9	90159-06010	•SCREW, with washer	6	
10	90560-25153	SPACER	1	
11	583-16111-00	GEAR, Primary drive (30T)	1	
12	90282-07021	KEY, straight	1	
13	90208-16019	WASHER, conical spring	1	
14	90170-16182	NUT	1	
15	363-16154-00	PLATE, thrust 1	1	
16	214-16119-00	SPRING, belleville	1	
17	90170-18086	NUT	1	
18	174-16356-00	ROD, Push 1	1	
19	583-16357-01	ROD, Push 2	1	
20	583-16382-00	AXLE, Push lever	1	
21	214-16389-00	JOINT	1	
22	90240-06005	PIN, clevis	1	
23	91401-10010	PIN, cotter	1	
24	90508-12279	SPRING, torsion	1	
25	93315-11720	BEARING, cylindrical	2	
26	93102-17148	OIL SEAL	1	
27	90201-17327	WASHER, Plate	1	
28	364-16343-00	SCREW, adjusting	1	
29	583-16344-00	NUT, adjusting	1	
30	90201-12172	WASHER, Plate	1	

FIG. 15 TRANSMISSION



REF. NO.	PART NO.	DESCRIPTION	Q'TY	REMARKS
1	583-17411-01	AXLE, main (14T)	1	
2	168-17428-01-05	SHIM 2 (0.5T)	1	
3	93304-20501	BEARING (B4205)	1	
4	583-17121-00	GEAR, 2nd Pinion (18T)	1	
5	583-17131-02	GEAR, 3rd Pinion (21T)	1	
6	583-17141-00	GEAR, 4th Pinion (24T)	1	
7	583-17151-01	GEAR, 5th Pinion (27T)	1	
8	90201-25287	WASHER, Plate	3	
9	93440-25020	CIRCLIP	3	
10	90201-20266	WASHER, Plate	1	
11	93311-42012	BEARING, cylindrical	1	
12	2H0-17421-00	AXLE, drive	1	
13	90338-09066	PLUG	1	
14	583-17211-00	GEAR, 1st wheel (33T)	1	
15	583-17221-00	GEAR, 2nd wheel (28T)	1	
16	583-17231-01	GEAR, 3rd wheel (25T)	1	
17	583-17241-00	GEAR, 4th wheel (22T)	1	
18	583-17251-01	GEAR, 5th wheel (21T)	1	
19	90201-25287	WASHER, Plate	3	
20	93440-25020	CIRCLIP	3	
21	90201-20278	WASHER, Plate	1	
22	93410-20038	CIRCLIP	2	
23	90201-20266	WASHER, Plate	1	
24	93313-32008	BEARING, cylindrical	1	
25	93306-30517	BEARING (B6305)	1	
26	93102-35180	OIL SEAL	1	
27	90387-25507	COLLAR	1	
28	93210-22298	O-RING	1	
29	214-17461-50	SPROCKET, drive (15T)	1	UR STD
	214-17461-40	SPROCKET, drive (14T)	1	UR

FIG. 15 TRANSMISSION

REF. NO.	PART NO.	DESCRIPTION	Q'TY	REMARKS
29	214-17461-60	SPROCKET, drive (16T)	1	UR
30	90215-21022	WASHER, lock	1	
31	90179-18020	NUT	1	

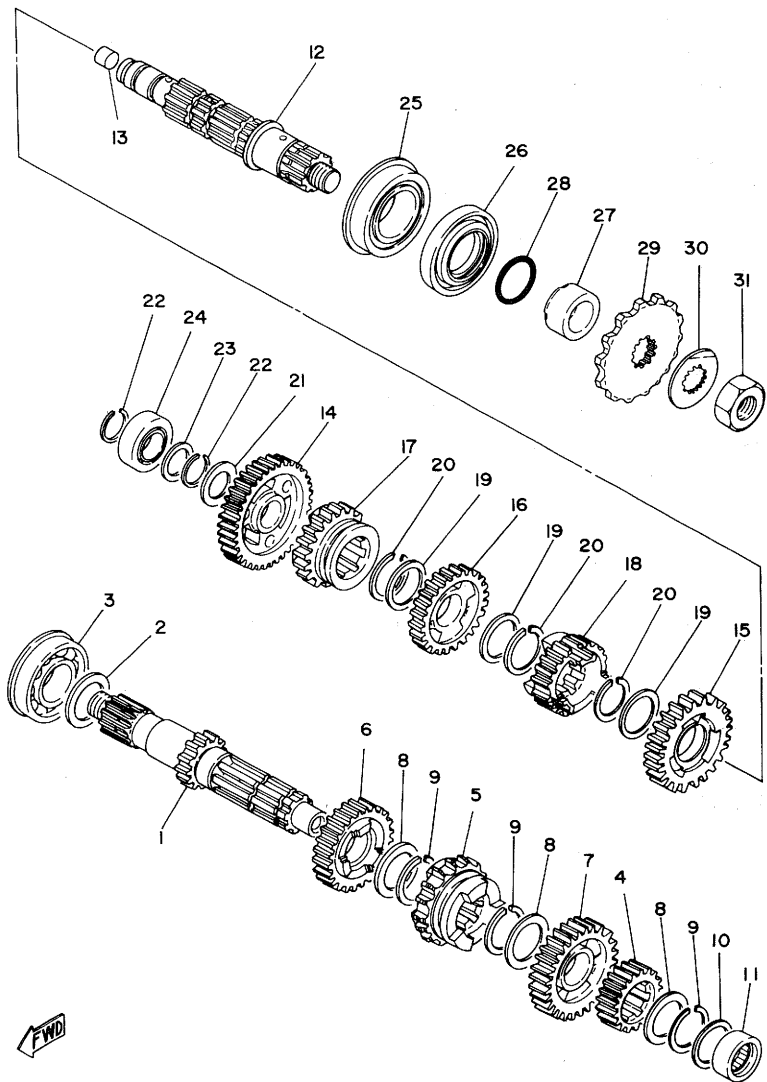
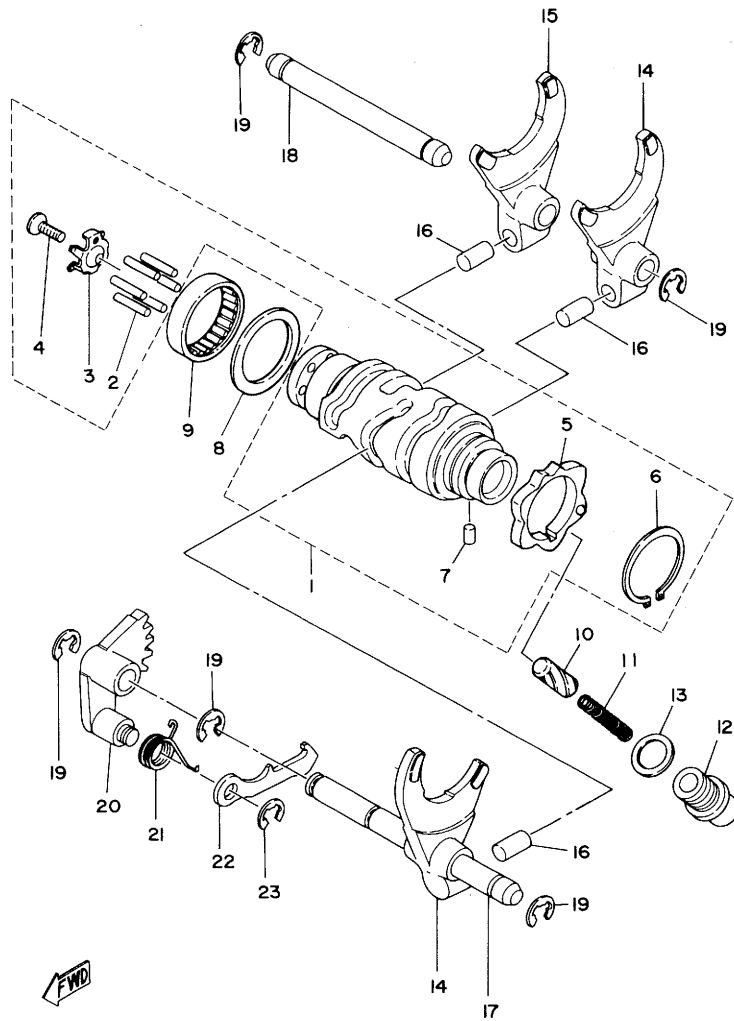
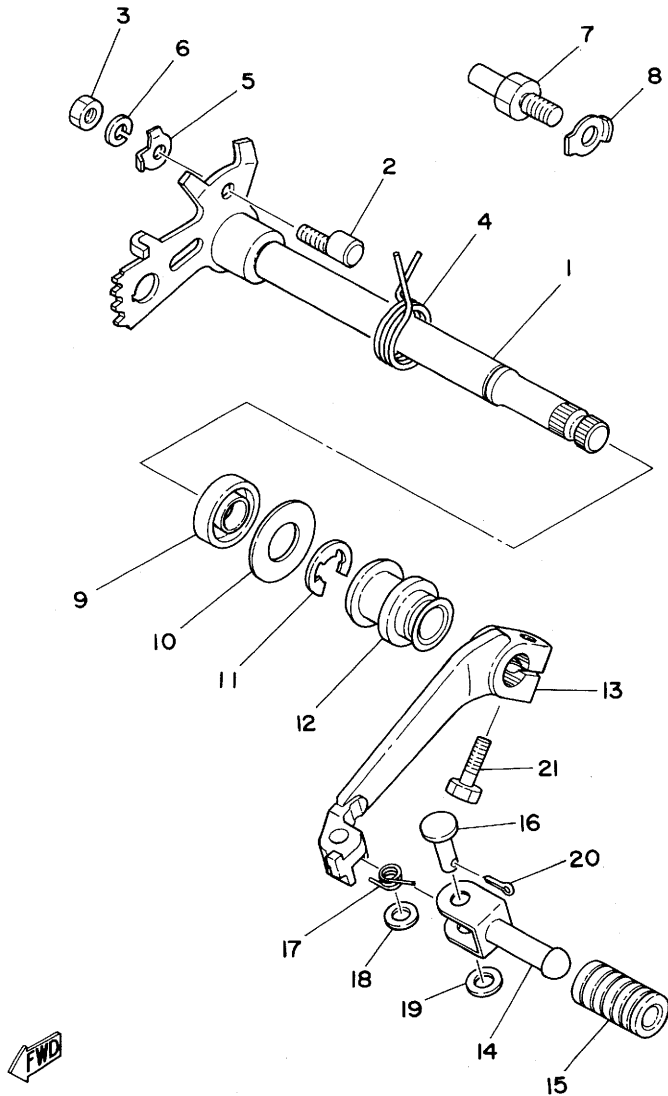

FIG. 16 SHIFT CAM.FORK



REF. NO.	PART NO.	DESCRIPTION	Q'TY	REMARKS
1	2Y0-18540-00	SHIFT CAM ASSY	1	
2	93604-18100	•PIN, dowel	6	
3	434-18561-00	•PLATE, side 1	1	
4	98701-05012	•SCREW, flat head	1	
5	2J2-18141-00	•PLATE, stopPer	1	
6	93410-30012	•CIRCLIP	1	
7	93604-08071	•PIN, dowel	1	
8	90201-32673	WASHER, Plate	1	
9	93315-23208	BEARING, cylindrical	1	
10	1J7-18547-00	STOPPER, cam	1	
11	90501-10062	SPRING, comPression	1	
12	90149-14031	SCREW	1	
13	137-15353-00	GASKET, drain	1	
14	364-18511-00	FORK, shift 1	2	
15	363-18511-00	FORK, shift 1	1	
16	90250-08017	PIN, straight	3	
17	363-18531-00	BAR, shift fork guide 1	1	
18	363-18535-00	BAR, shift fork guide 2	1	
19	93430-08006	CIRCLIP	5	
20	434-18122-00	LEVER, shift 2	1	
21	90508-08334	SPRING, torsion	1	
22	498-18151-03	LEVER, shift 3	1	
23	93430-07012	CIRCLIP	1	

FIG. 17 SHIFT SHAFT•PEDAL



REF. NO.	PART NO.	DESCRIPTION	Q'TY	REMARKS
1	2J2-18103-00	SHIFT SHAFT COMP.	1	
2	90149-06017	SCREW	1	
3	95301-06600	NUT	1	
4	90508-32052	SPRING, torsion	1	
5	90215-06016	WASHER, lock	1	
6	92901-06100	WASHER, sPring	1	
7	278-18127-00	STOPPER, screw	1	
8	90215-08115	WASHER, lock	1	
9	93109-14010	OIL SEAL	1	
10	90201-14220	WASHER, Plate	1	
11	93430-12009	CIRCLIP	1	
12	583-18131-00	BOOT, sealing	1	
13	2Y0-18111-00-33	ARM, shift	1	yamaha black
14	1W6-18162-00	PEDAL, shift	1	
15	1W6-18113-00	COVER, shift Pedal	1	
16	90240-06057	PIN, clevis	1	
17	90508-16351	SPRING, torsion	1	
18	92901-06600	WASHER, Plate	1	
19	92901-06200	WASHER, Plain	1	
20	91401-20012	PIN, cotter	1	
21	97321-06020	BOLT	1	

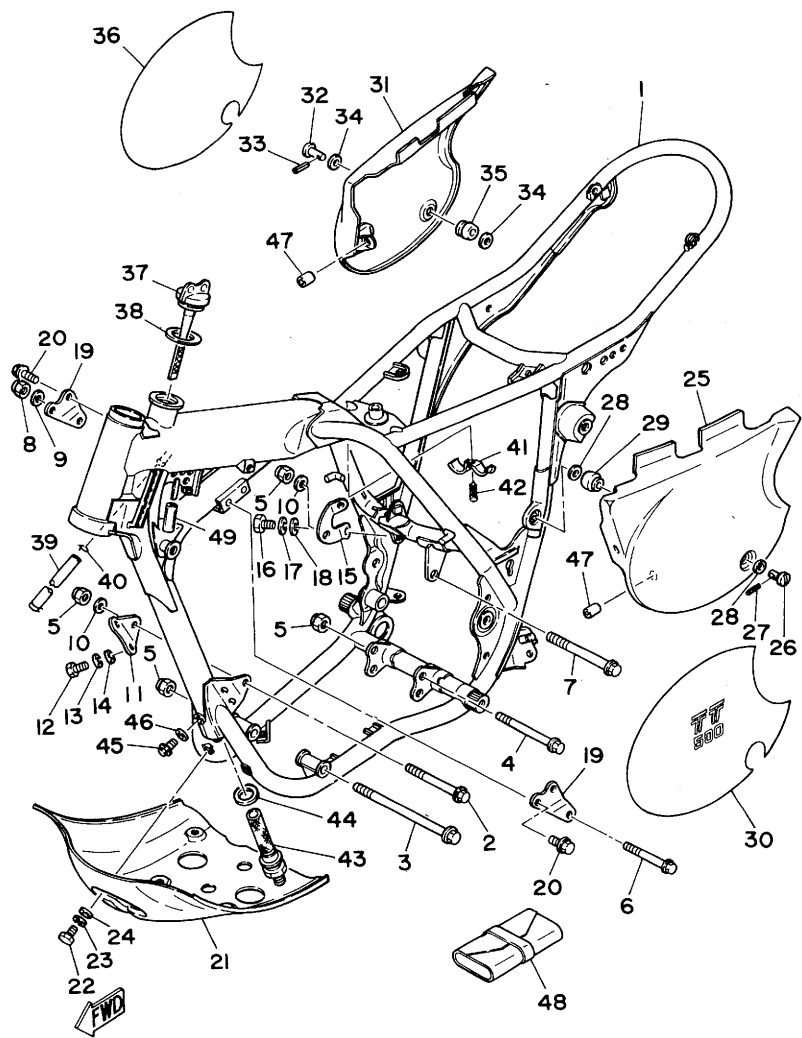
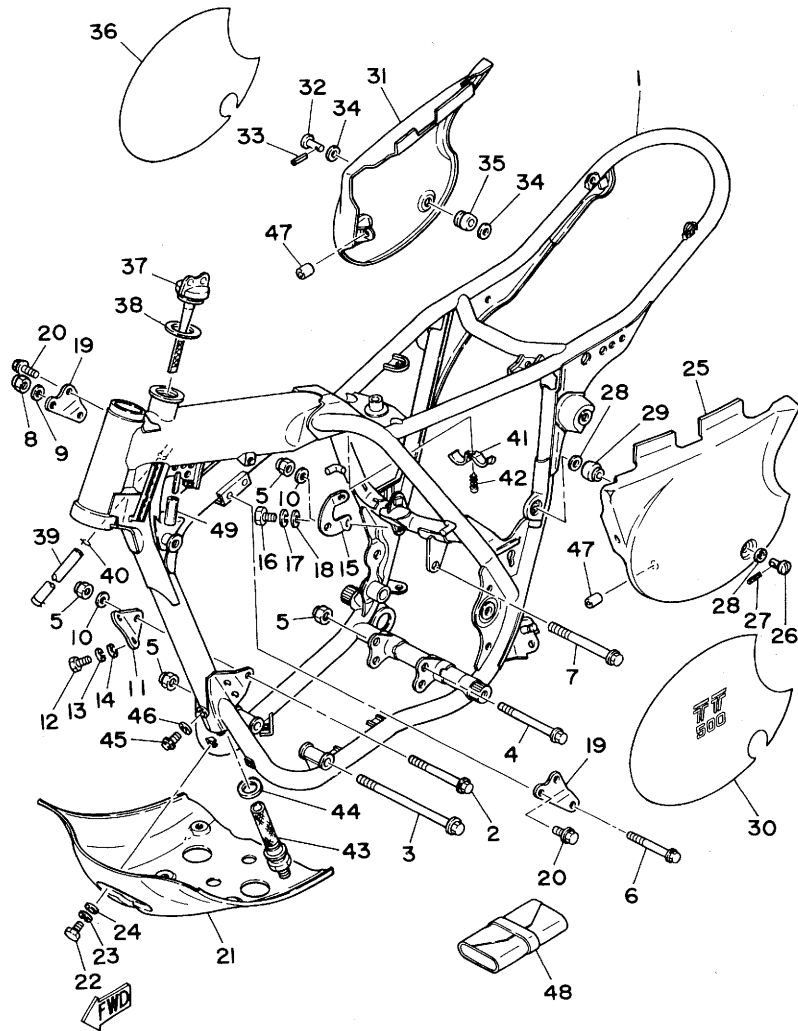

FIG. 18 FRAME

REF. NO.	PART NO.	DESCRIPTION	Q'TY	REMARKS
1	2Y0-21110-00-33	FRAME COMP	1	yamaha black
2	90105-10039	BOLT, washer based	1	
3	90105-10063	BOLT, washer based	1	
4	90105-10050	BOLT, washer based	1	
5	90185-10035	NUT, self-locking	4	
6	90105-08064	BOLT, washer based	1	
7	90105-10051	BOLT, washer based	1	
8	90185-08054	NUT, self-locking	1	
9	90208-08011	WASHER, conical sPring	1	
10	90201-10126	WASHER, Plate	2	
11	583-21316-00	STAY, engine mount	1	
12	97321-08025	BOLT	2	
13	92901-08100	WASHER, sPring	2	
14	92901-08600	WASHER, Plate	2	
15	1T1-21317-00	STAY, engine mount rear	1	
16	97321-08025	BOLT	2	
17	92901-08100	WASHER, sPring	2	
18	92901-08600	WASHER, Plate	2	
19	583-21315-00	STAY, engine 2	2	
20	90105-08066	BOLT, washer based	4	
21	1T1-21471-01	PROTECTOR, engine	1	
22	97301-06014	BOLT	5	
23	92901-06100	WASHER, sPring	5	
24	90201-06557	WASHER, Plate	5	
25	2Y0-21711-10-33	COVER, side (L.H)	1	
26	583-21714-00	KNOB, side cover 1	1	
27	91609-25018	PIN, sPring	1	
28	90201-06063	WASHER, Plate	2	
29	583-21747-00	DAMPER	1	
30	2Y0-21786-10	EMBLEM 6	1	

FIG. 18 FRAME



REF. NO.	PART NO.	DESCRIPTION	Q'TY	REMARKS
31	2Y0-21721-10-33	COVER, side (R.H)	1	
32	583-21714-00	KNOB, side cover 1	1	
33	91609-25018	PIN, sPring	1	
34	90201-06063	WASHER, Plate	2	
35	583-21747-00	DAMPER	1	
36	2Y0-21787-10	EMBLEM 7	1	
37	583-21771-00	BODY, caP	1	
38	90430-27124	GASKET	1	
39	90445-11289	HOSE	1	
40	90467-10008	CLIP	2	
41	583-21755-00	CLAMP	1	
42	97701-50110	SCREW, Panhead tapping	1	
43	583-21756-00	NET, filter	1	
44	90430-22123	GASKET	1	
45	95801-08012	BOLT, flange	1	
46	90430-08119	GASKET	1	
47	90445-11418	HOSE	2	
48	583-28100-10	TOOL KIT	1	
49	90446-07114	HOSE	1	

FIG. 19 FRONT FENDER•REAR FENDER

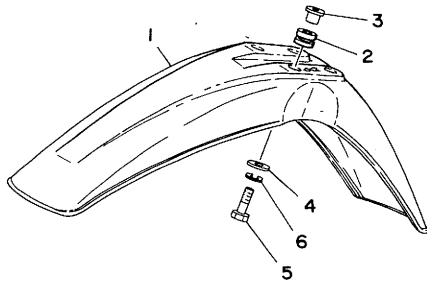
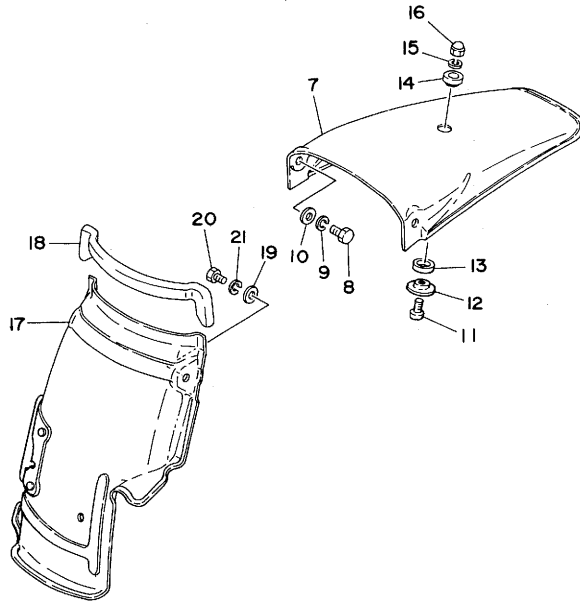

FWD

REF. NO.	PART NO.	DESCRIPTION	Q'TY	REMARKS
1	3H6-21511-00	FENDER, front	1	clean white
2	90480-14198	GROMMET	4	
3	90387-06388	COLLAR	4	
4	90201-06067	WASHER, Plate	4	
5	97301-06030	BOLT	4	
6	92901-06100	WASHER, sPring	4	
7	583-21611-00	FENDER, rear	1	clean white
8	97321-06014	BOLT	2	
9	92901-06100	WASHER, sPring	2	
10	90201-06571	WASHER, Plate	2	
11	92501-06018	SCREW, Pan head	1	
12	90209-06087	WASHER	1	
13	322-21639-00	DAMPER 2	1	
14	322-21541-00	DAMPER 1	1	
15	92901-06100	WASHER, sPring	1	
16	95303-06800	NUT, crown	1	
17	1T1-21620-00	MUD GUARD COMP.	1	
18	583-21746-00	SEAL, box	1	
19	90201-06067	WASHER, Plate	3	
20	97321-06014	BOLT	3	
21	92901-06100	WASHER, sPring	3	

FIG. 20 REAR ARM SUSPENSION

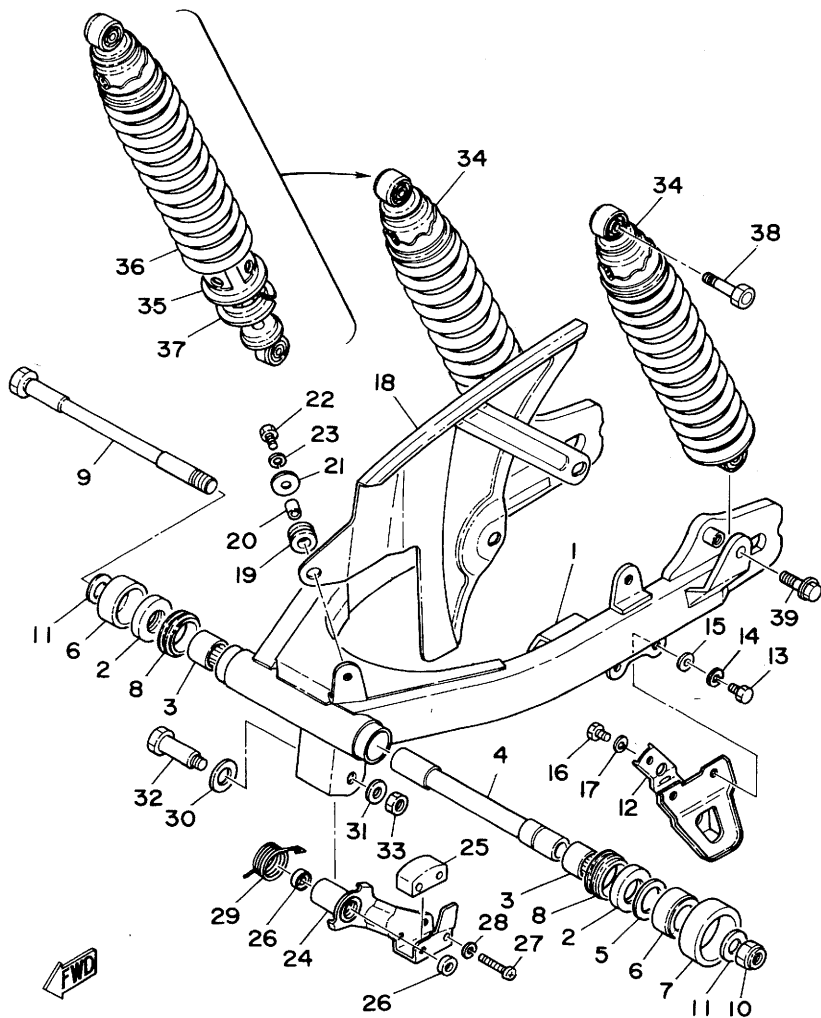

REF. NO.	PART NO.	DESCRIPTION	Q'TY	REMARKS
1	2Y0-22110-01-35	REAR ARM COMP.	1	silver
2	93342-22205	BEARING	2	
3	93317-22208	BEARING, cylindrical	2	
4	483-22124-00	BUSH 2	1	
5	648-45533-00-03	SHIM (0.3T)	1	UR
6	2K8-22129-00	COVER, thrust 2	2	
7	431-22151-03	SEAL, Guard	1	
8	93108-35004	OIL SEAL	2	
9	583-22141-01	SHAFT, Pivot	1	
10	95601-16100	NUT, u	1	
11	90208-16019	WASHER, conical sPring	2	
12	2Y0-22153-00-33	GUARD, chain	1	yamaha black
13	97301-06018	BOLT	2	
14	92901-06100	WASHER, sPring	2	
15	92901-06600	WASHER, Plate	2	
16	97301-06016	BOLT	1	
17	92901-06100	WASHER, sPring	1	
18	2Y0-22311-01-33	CASE, chain	1	yamaha black
19	90480-12188	GROMMET	3	
20	90560-05001	SPACER	3	
21	90201-06407	WASHER, Plate	3	
22	97301-05014	BOLT	3	
23	92901-05100	WASHER, sPring	3	
24	2Y0-22179-00	ARM, tensioner	1	
25	2N0-22178-00	TENSIONER	1	
26	93104-14044	OIL SEAL	2	
27	98501-05040	SCREW, Pan head	2	
28	92901-05100	WASHER, sPring	2	
29	90508-35387	SPRING, torsion	1	
30	90201-14215	WASHER, Plate	1	

FIG. 20 REAR ARM SUSPENSION

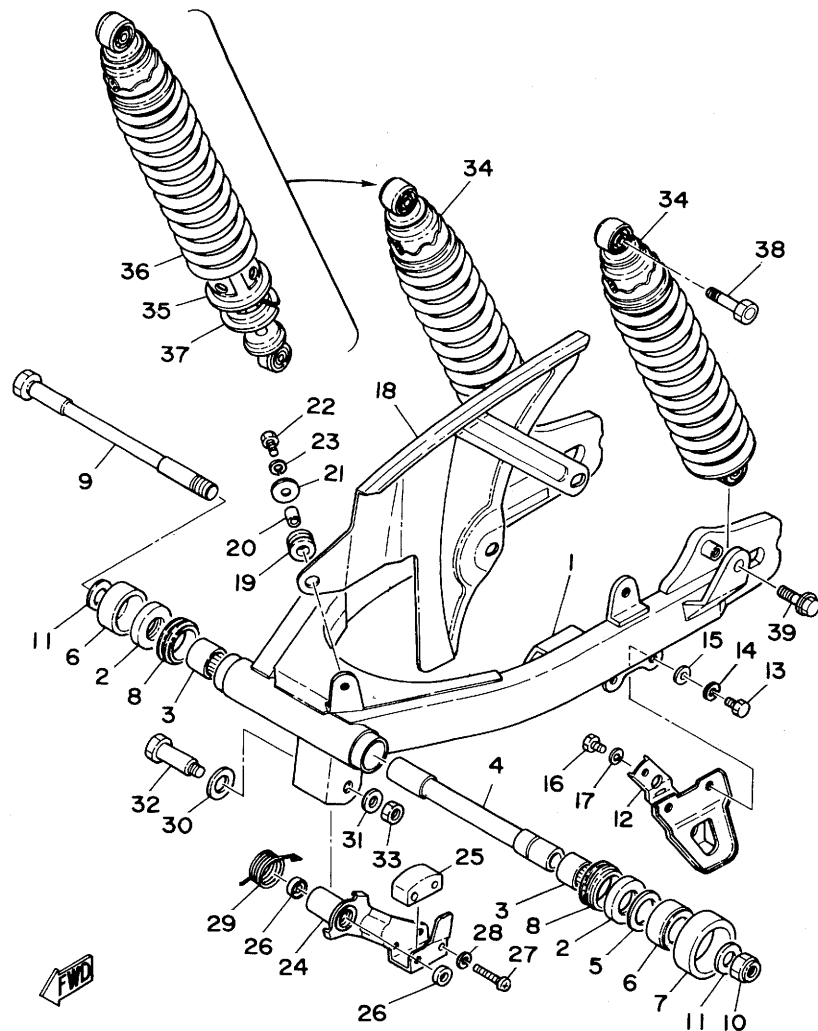

REF. NO.	PART NO.	DESCRIPTION	Q'TY	REMARKS
31	90201-10141	WASHER, Plate	1	
32	90109-10533	BOLT	1	
33	95301-10700	NUT	1	
34	2Y0-22210-00	SHOCK ABSORBER ASSY, rear	2	
35	1T1-22211-00	•GUIDE, sPring	2	
36	1T1-22212-00	•SPRING	2	
37	583-22214-00	•SEAT, sPring	2	
38	90109-10420	BOLT	2	
39	90105-10104	BOLT, washer based	2	

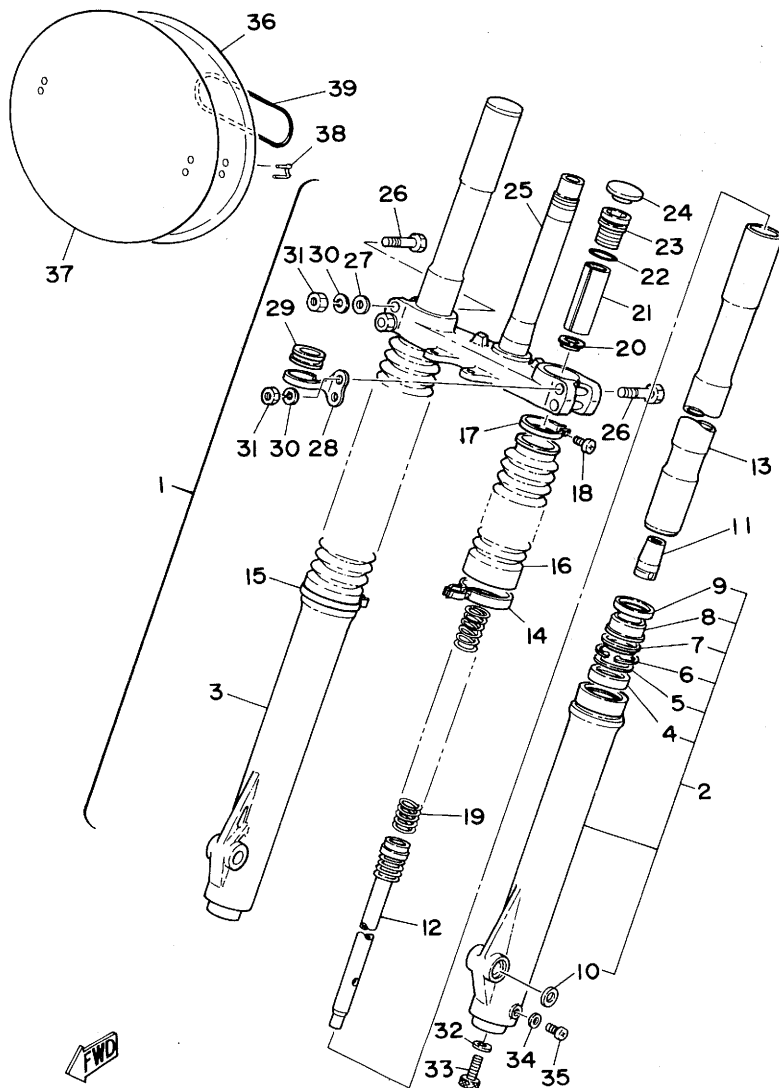
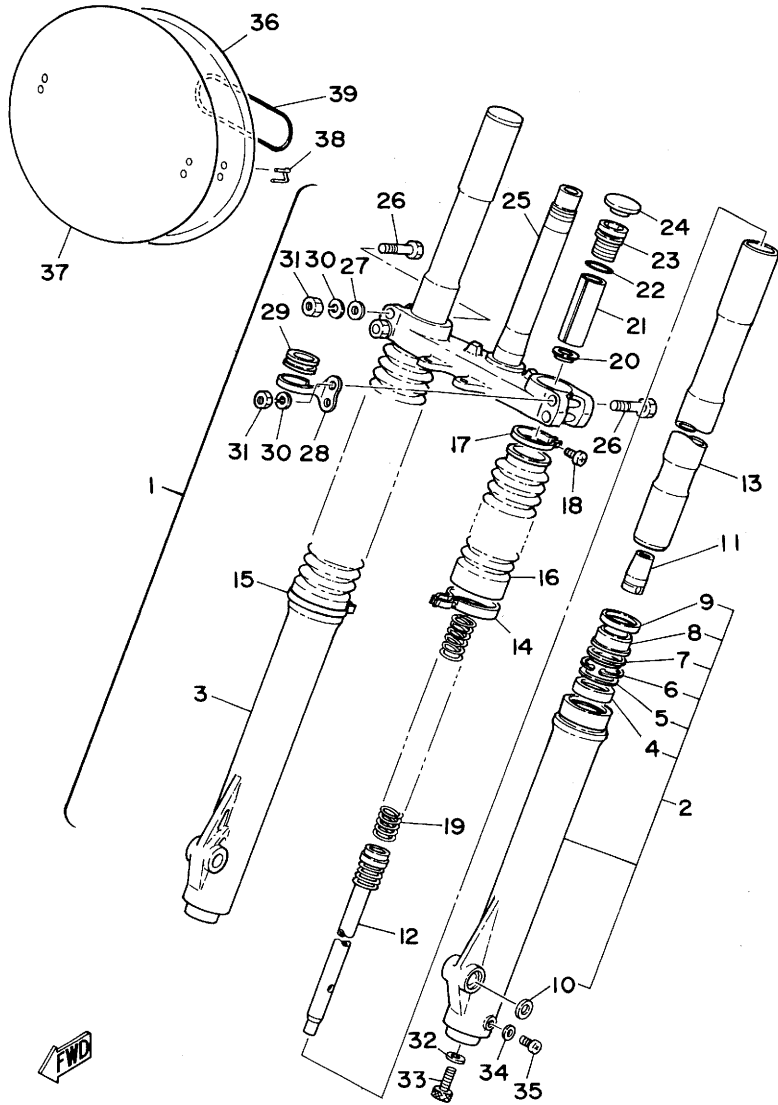

FIG. 21 FRONT FORK

REF. NO.	PART NO.	DESCRIPTION	Q'TY	REMARKS
1	2Y0-23101-00	FRONT FORK ASSY	1	
2	2W6-23126-00	•TUBE, outer 1	1	
3	2W6-23136-00	•TUBE, outer 2	1	
4	1K7-23145-00	••OIL SEAL	2	
5	509-23146-L0	••WASHER, oil seal	2	
6	1W1-23156-L0	••CLIP, oil seal	2	
7	1W1-23153-L0	••RING, snaP	2	
8	1G8-23144-L1	••SEAL, dust	2	
9	1W1-23148-L0	••COVER, dust seal	2	
10	1W1-23168-L0	••WASHER, outer tube	2	
11	2Y0-23173-00	•SPINDLE, taPer	2	
12	2Y0-23170-00	•CYLINDER COMP., front fork	2	
13	2Y0-23124-00	•TUBE, inner 1	2	
14	1W1-23318-L0	•HOLDER, cable 1	1	
15	509-23489-L0	•BAND	1	
16	2N6-23191-00	•BOOT	2	
17	341-92090-60	•BAND, boot	2	
18	509-23194-L0	•SCREW, boot band	2	
19	2Y0-23141-00	•SPRING, front fork	2	
20	583-23142-00	•SEAT, sPrinG uPPer	2	
21	1T2-23118-00	•SPACER	2	
22	240-23114-00	•GASKET	2	
23	1U6-23111-M1	•BOLT, caP	2	
24	1U6-23168-M0	•CAP, front fork	2	
25	2Y0-23340-00-33	•UNDER BRACKET COMP.	1	yamaha black
26	90109-08397	•BOLT	4	
27	90201-08544	•WASHER, Plate	2	
28	1W1-23317-01	•HOLDER, cable	1	
29	1W1-23389-00	•GUIDE, cable	1	
30	92901-08100	•WASHER, sPrinG	4	

FIG. 21 FRONT FORK



REF. NO.	PART NO.	DESCRIPTION	Q'TY	REMARKS
31	95311-08600	•NUT	4	
32	509-23158-L0	•GASKET	2	
33	278-23181-50	•BOLT, hexagon socket head	2	
34	122-23129-00	•GASKET, drain Plug	2	
35	122-23119-01	•PLUG, drain	2	
36	583-23485-00	PLATE, number	1	
37	322-23395-00	EMBLEM	1	
38	431-23486-02	STAY, Plate	2	
39	93210-69355	O-RING	2	

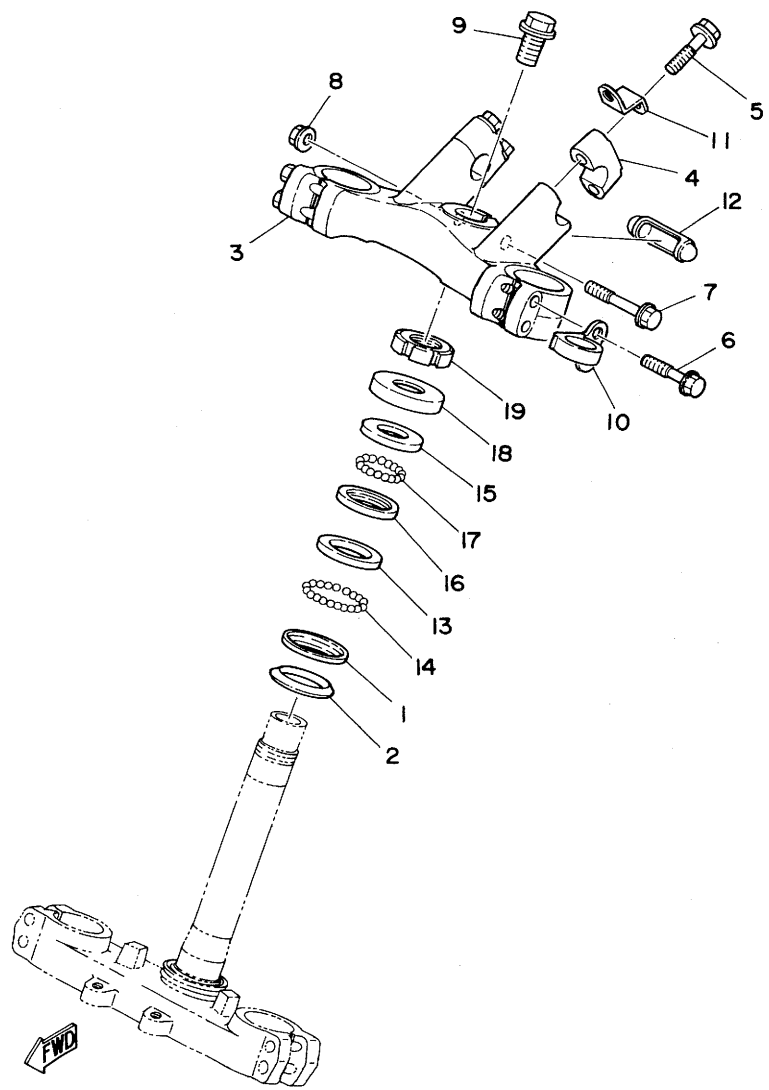
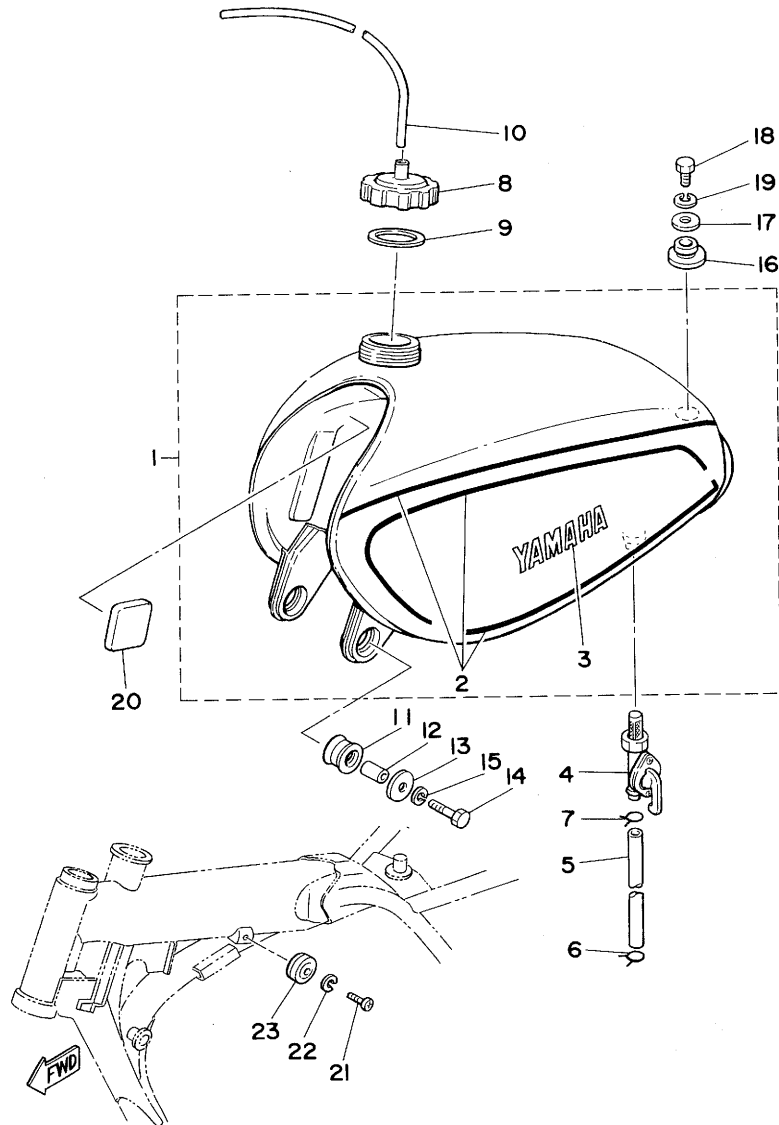

FIG. 22 STEERING

REF. NO.	PART NO.	DESCRIPTION	Q'TY	REMARKS
1	156-23411-00	RACE, ball 1	1	
2	164-23462-00	SEAL, steering	1	
3	1W1-23435-01-98	CROWN, handle	1	low gloss black
4	1E6-23441-00-98	HOLDER, handle upper	2	low gloss black
5	95821-08035	BOLT, flange	4	
6	95821-08040	BOLT, flange	4	
7	95821-08055	BOLT, flange	1	
8	95701-08100	NUT, flange	1	
9	90105-14060	BOLT, washer based	1	
10	3R4-23317-00	HOLDER, cable	1	
11	1T2-23389-00	GUIDE, cable	1	
12	583-23469-00	CAP, bolt	1	
13	156-23412-00	RACE, ball 2	1	
14	93501-04011	BALL	19	
15	122-23411-00	RACE, ball 1	1	
16	122-23412-00	RACE, ball 2	1	
17	93503-16010	BALL	22	
18	2Y0-23416-00	COVER, ball race 2	1	
19	90179-25033	NUT	1	

FIG. 23 FUEL TANK



REF. NO.	PART NO.	DESCRIPTION	Q'TY	REMARKS
1	2Y0-24110-00-02	FUEL TANK COMP.	1	new yamaha black
2	2Y0-24240-00	GRAPHIC SET	1	
3	322-24161-00	EMBLEM 1	2	
4	322-24500-02	FUEL COCK ASSY 1	1	
5	90445-11288	HOSE	1	
6	90467-10008	CLIP	1	
7	90467-11010	CLIP	1	
8	2A6-24611-00	BODY, caP	1	
9	1W1-24612-00	GASKET, caP	1	
10	90445-09111	HOSE	1	
11	90480-22177	GROMMET	2	
12	90387-09506	COLLAR	2	
13	90201-06073	WASHER, Plate	2	
14	97321-06030	BOLT	2	
15	92901-06100	WASHER, sPring	2	
16	90480-22054	GROMMET	1	
17	90209-08097	WASHER	1	
18	97301-08016	BOLT	1	
19	92901-08100	WASHER, sPring	1	
20	583-24181-00	DAMPER, locating 1	2	
21	98501-05012	SCREW, Pan head	2	
22	92901-05100	WASHER, sPring	2	
23	583-24182-00	DAMPER, locating 2	2	

FIG. 24 SEAT

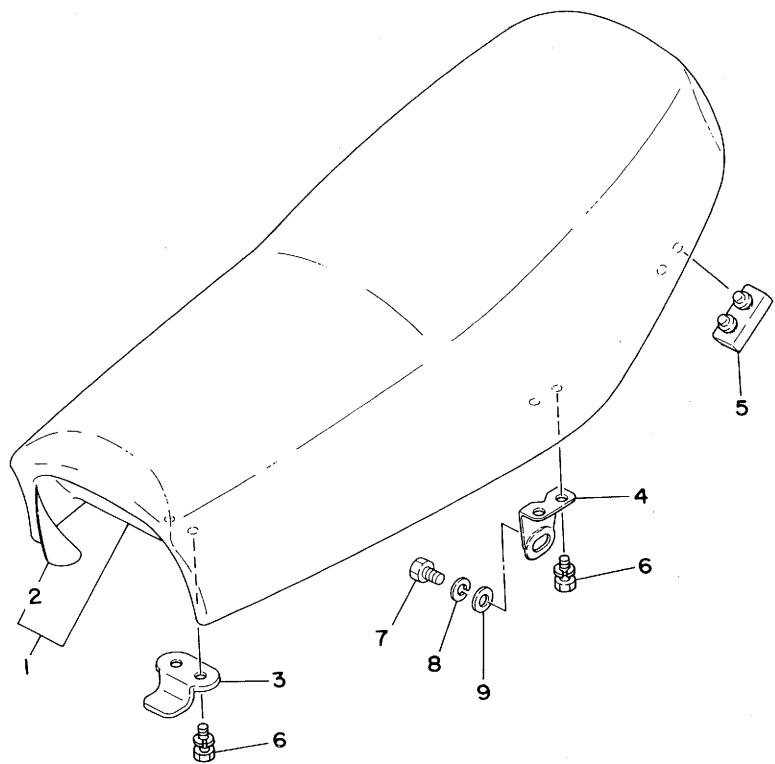

REF. NO.	PART NO.	DESCRIPTION	Q'TY	REMARKS
1	2Y0-W2473-00	SEMI-DOUBLE SEAT ASSY	1	
2	2Y0-24731-00	COVER, double seat	1	
3	2Y0-24748-00	BRACKET, seat	1	
4	1T1-24738-00	BRACKET, seat	2	
5	583-24724-00	DAMPER, seat	2	
6	90101-06304	BOLT	6	
7	97321-08016	BOLT	2	
8	92901-08100	WASHER, sPring	2	
9	92901-08600	WASHER, Plate	2	

FWD

FIG. 25 FRONT WHEEL

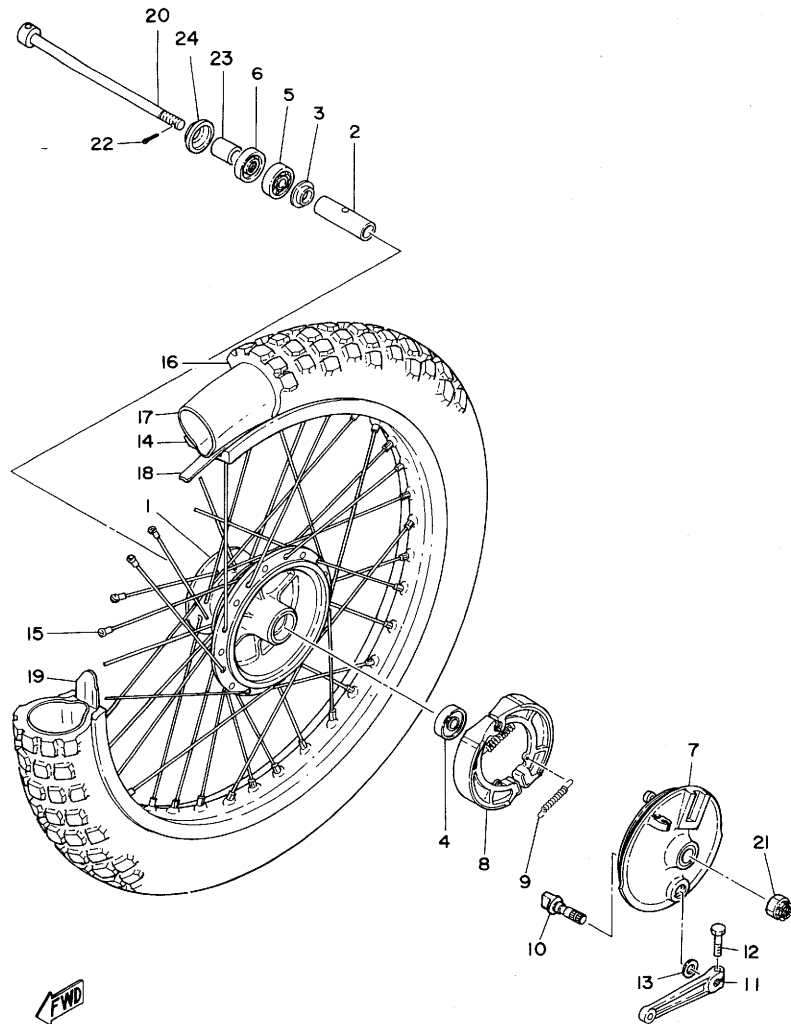

REF. NO.	PART NO.	DESCRIPTION	Q'TY	REMARKS
1	1K7-25111-10-98	HUB, front	1	low gloss black
2	90560-15116	SPACER	1	
3	146-25116-00	FLANGE, sPacer 2	1	
4	93306-20203	BEARING (B6202RS)	1	
5	93306-20205	BEARING (B6202)	1	
6	93102-20009	OIL SEAL	1	
7	1W1-25121-01-98	PLATE, brake shoe	1	low gloss black
8	322-25130-00	BRAKE SHOE COMP.	2	
9	90506-16036	SPRING, tension	2	
10	322-25151-00	CAMSHAFT	1	
11	322-25155-00	LEVER, camshaft 1	1	
12	90101-06291	BOLT	1	
13	137-25159-00	SEAL, camshaft	1	
14	94416-21104	RIM (1.60-21)	1	
15	2W6-25104-01	SPOKE SET, front	1	
16	94130-21510	TIRE (3.00-21)	1	
17	94227-21101	TUBE (2.75-21)	1	
18	94327-21071	BAND, rim (2.75-21)	1	
19	1T1-25194-00	SPACER, bead	1	
20	1W1-25181-00	AXLE, wheel	1	
21	90171-14020	NUT, castle	1	
22	91401-30030	PIN, cotter	1	
23	90387-15535	COLLAR	1	
24	322-25118-00	COVER, hub dust	1	

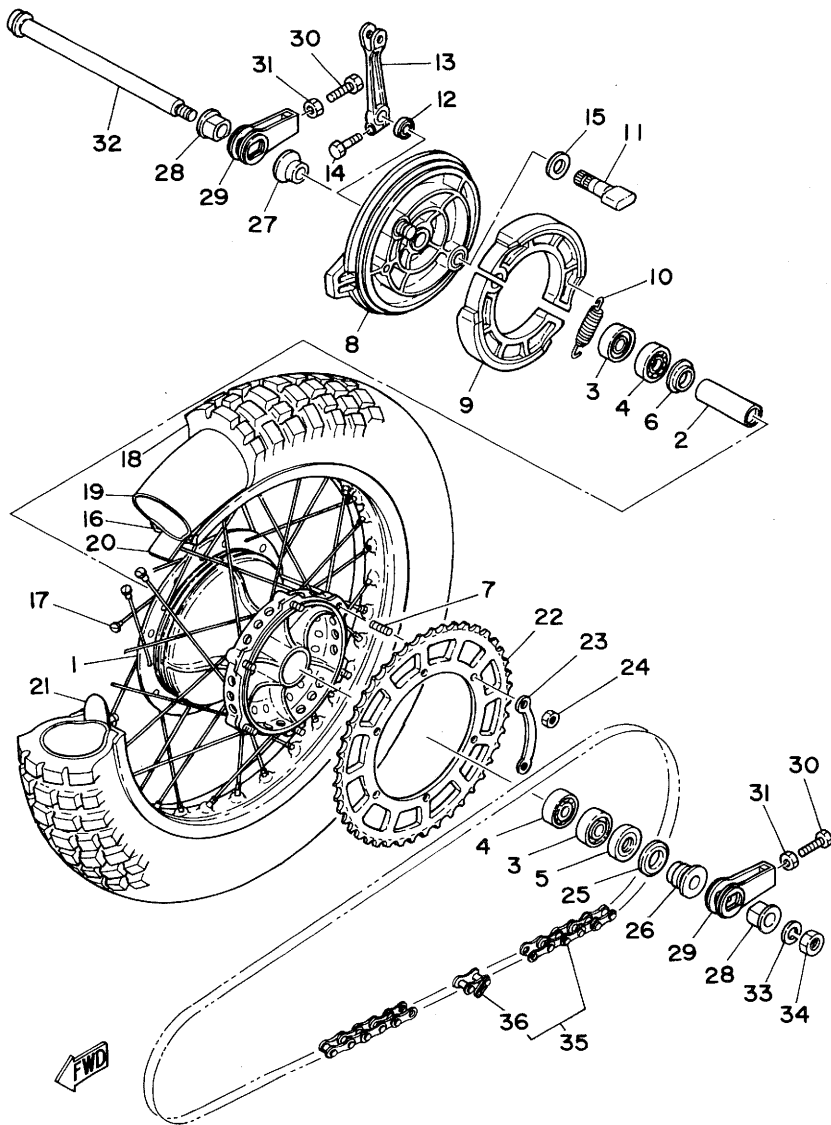

FIG. 26 REAR WHEEL

REF. NO.	PART NO.	DESCRIPTION	Q'TY	REMARKS
1	483-25311-13-98	HUB, rear	1	low gloss black
2	483-25317-01	SPACER, bearing	1	
3	93306-20310	BEARING (B6203RS)	2	
4	93306-20316	BEARING (B6203)	2	
5	93102-25030	OIL SEAL	1	
6	483-25315-00	FLANGE, spacer	1	
7	90116-08218	BOLT, stud	6	
8	1W4-25321-00-98	PLATE, brake shoe	1	low gloss black
9	1W4-25330-01	BRAKE SHOE COMP.	2	
10	90507-20002	SPRING, tension	2	
11	1E2-25151-00	CAMSHAFT	1	
12	148-25359-00	SEAL, camshaft	1	
13	2Y0-25355-00	LEVER, camshaft	1	
14	90101-06291	BOLT	1	
15	148-25353-00	SHIM, camshaft	1	
16	94421-18105	RIM (2.15-18)	1	
17	431-25304-01	SPOKE SET, rear	1	
18	94146-18511	TIRE (4.60-18)	1	
19	94240-18098	TUBE (4.00-18)	1	
20	94340-18069	BAND, rim (4.00-18)	1	
21	1T1-25394-01	SPACER, bead	2	
22	583-25450-10	SPROCKET, driven (50T)	1	UR STD
	583-25440-10	SPROCKET, driven (40T)	1	UR
	583-25442-10	SPROCKET, driven (42T)	1	UR
	583-25444-10	SPROCKET, driven (44T)	1	UR
	583-25446-10	SPROCKET, driven (46T)	1	UR
	583-25448-10	SPROCKET, driven (48T)	1	UR
	583-25452-10	SPROCKET, driven (52T)	1	UR
	583-25454-10	SPROCKET, driven (54T)	1	UR
23	583-25412-00	WASHER	3	

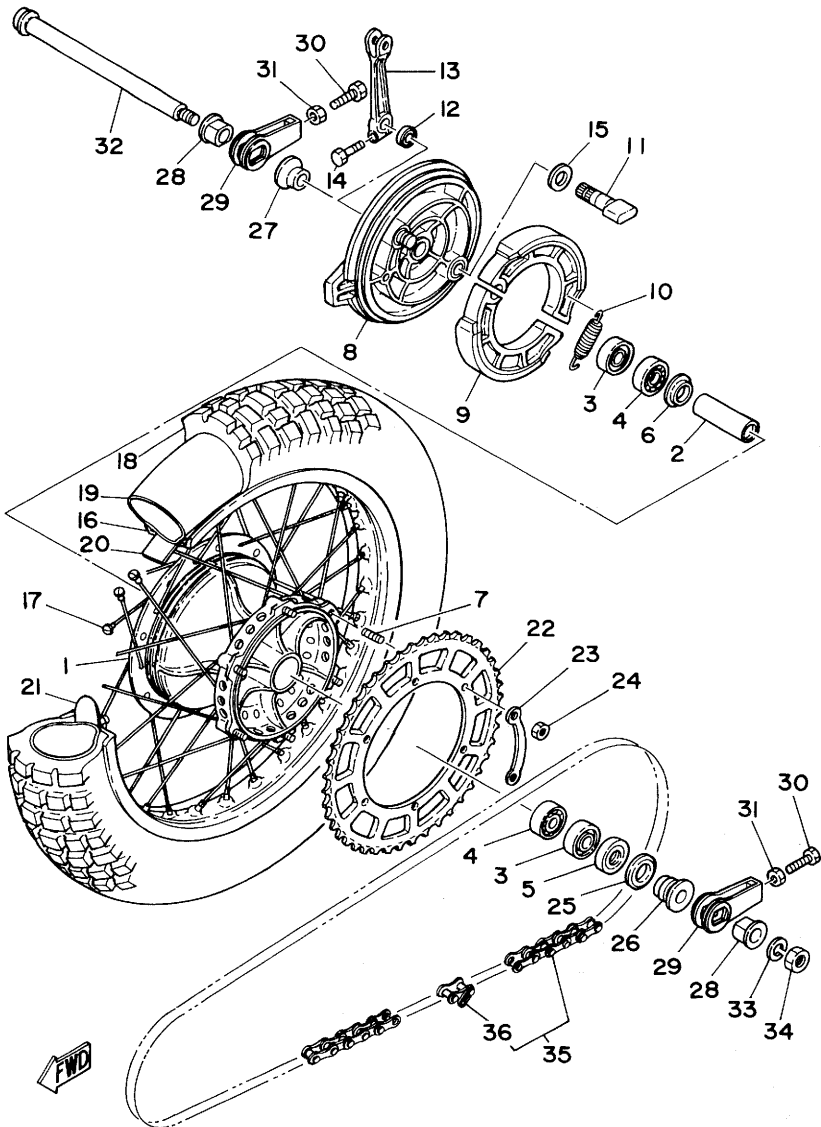
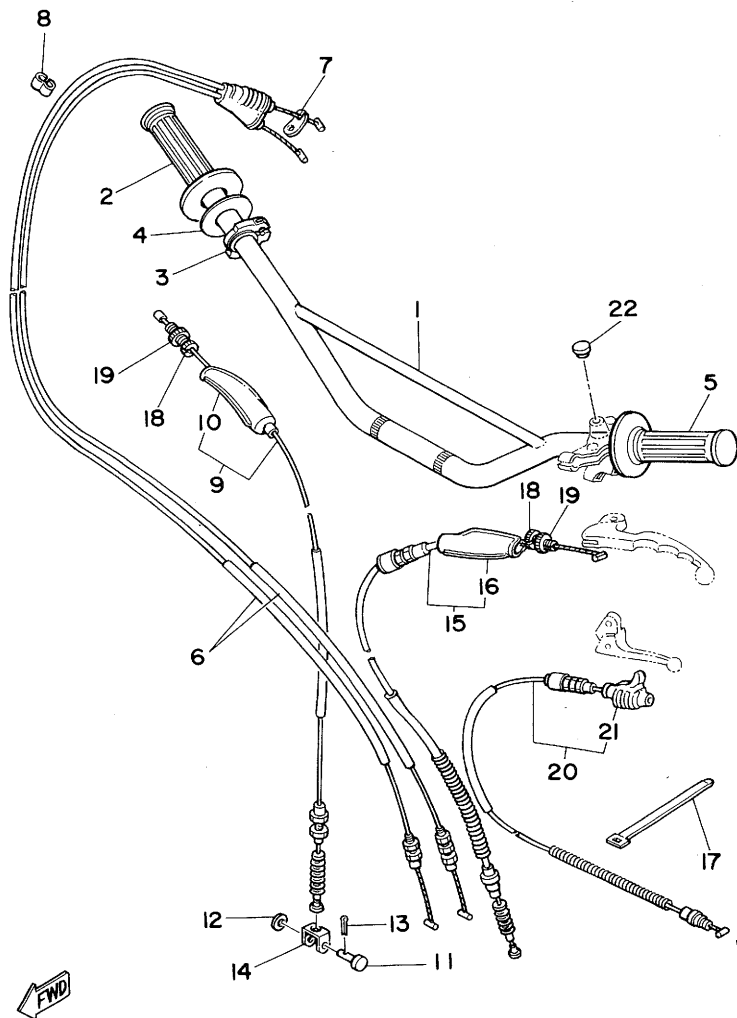

FIG. 26 REAR WHEEL

REF. NO.	PART NO.	DESCRIPTION	Q'TY	REMARKS
24	90170-08193	NUT	6	
25	431-25367-00	COVER, hub dust	1	
26	90387-17650	COLLAR	1	
27	90387-17651	COLLAR	1	
28	90381-17027	BUSH, solid	2	
29	2Y0-25388-00	PULLER, chain 1	2	
30	90101-08034	BOLT	2	
31	95301-08700	NUT	2	
32	2K8-25381-00	AXLE, wheel	1	
33	92901-16100	WASHER, spring	1	
34	90170-16177	NUT	1	
35	94585-20104	CHAIN, drive (DID520DS 104L)	1	
36	94685-20011	JOINT, chain	1	

FIG. 27 HANDLEBAR CABLE



REF. NO.	PART NO.	DESCRIPTION	Q'TY	REMARKS
1	2Y0-26111-00	HANDLEBAR	1	
2	583-26242-00	GRIP (R.H)	1	
3	2H0-26243-00	TUBE, throttle Guide	1	
4	1W1-26249-00	RING, leaf	1	
5	583-26241-00	GRIP (L.H)	1	
6	2H0-26301-00	THROTTLE CABLE ASSY	1	
7	583-26398-00	WASHER	1	
8	90468-15009	CLIP	2	
9	1W1-26341-01	CABLE, brake	1	
10	382-26372-01	.COVER, handle lever	1	
11	90240-08012	PIN, clevis	1	
12	90201-08083	WASHER, Plate	1	
13	91401-20012	PIN, cotter	1	
14	156-26347-00	JOINT, cable	1	
15	2Y0-26335-00	CABLE, clutch	1	
16	382-26372-01	.COVER, handle lever	1	
17	341-26397-01	BAND	1	
18	90123-08046	BOLT	2	
19	90179-08148	NUT	2	
20	583-26331-00	CABLE, decomPression	1	
21	583-26352-00	.COVER, decomPression cable	1	
22	90338-09012	PLUG	1	

FIG. 28 STAND•FOOTREST

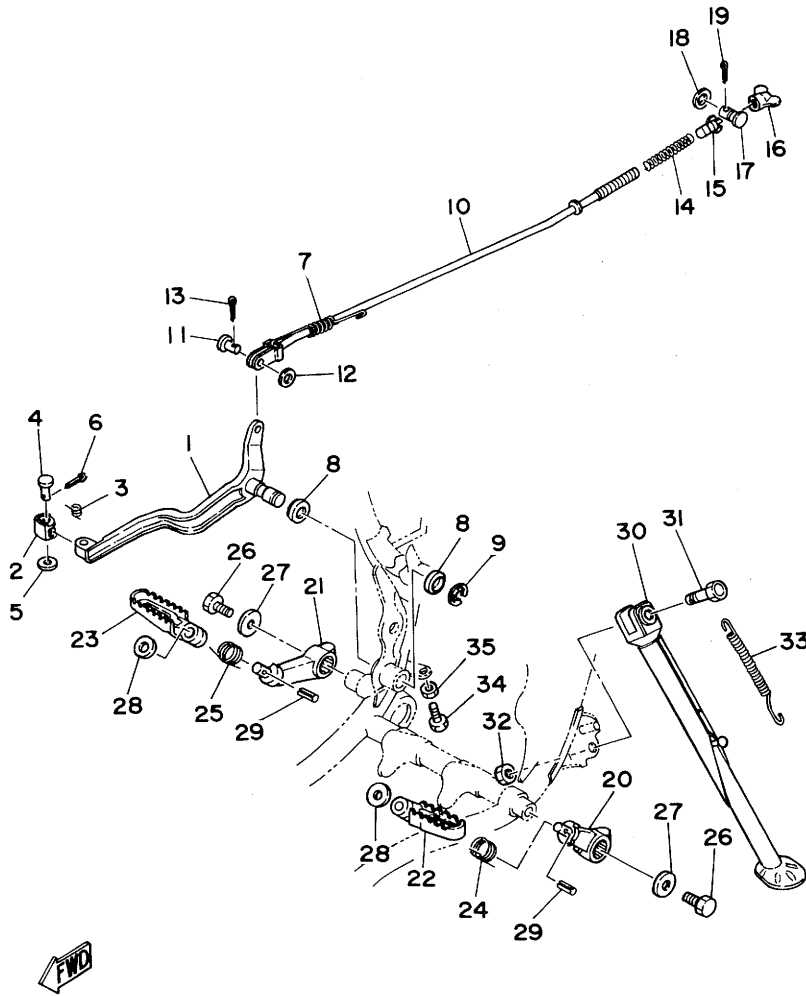

REF. NO.	PART NO.	DESCRIPTION	Q'TY	REMARKS
1	2Y0-27211-00-R4	ARM, brake	1	black
2	1W2-27242-00	PEDAL, brake	1	
3	90508-14352	SPRING, torsion	1	
4	91701-06022	PIN, clevis	1	
5	92901-06600	WASHER, Plate	1	
6	91401-20012	PIN, cotter	1	
7	90506-20128	SPRING, tension	1	
8	498-27235-00	COVER, dust	2	
9	93430-15023	CIRCLIP	1	
10	2Y0-27231-00	ROD, brake	1	
11	90240-08051	PIN, clevis	1	
12	807-14617-00	WASHER	1	
13	91401-20012	PIN, cotter	1	
14	90501-10245	SPRING, compression	1	
15	1W2-27239-00	SEAT, spring	1	
16	90175-06013	NUT, wing	1	
17	1W2-27237-00	PIN, clevis	1	
18	90201-12631	WASHER, Plate	1	
19	91401-25022	PIN, cotter	1	
20	2Y0-27412-00-33	BRACKET, footrest 1	1	yamaha black
21	2Y0-27422-00-33	BRACKET, footrest 2	1	yamaha black
22	583-27411-00	FOOTREST 1	1	
23	583-27421-00	FOOTREST 2	1	
24	90508-26277	SPRING, torsion	1	
25	90508-26276	SPRING, torsion	1	
26	97311-10016	BOLT	2	
27	90201-10639	WASHER, Plate	2	
28	90201-12631	WASHER, Plate	2	
29	91609-30020	PIN, spring	2	
30	2Y0-27311-00-33	STAND, side	1	yamaha black

FIG. 28 STAND.FOOTREST

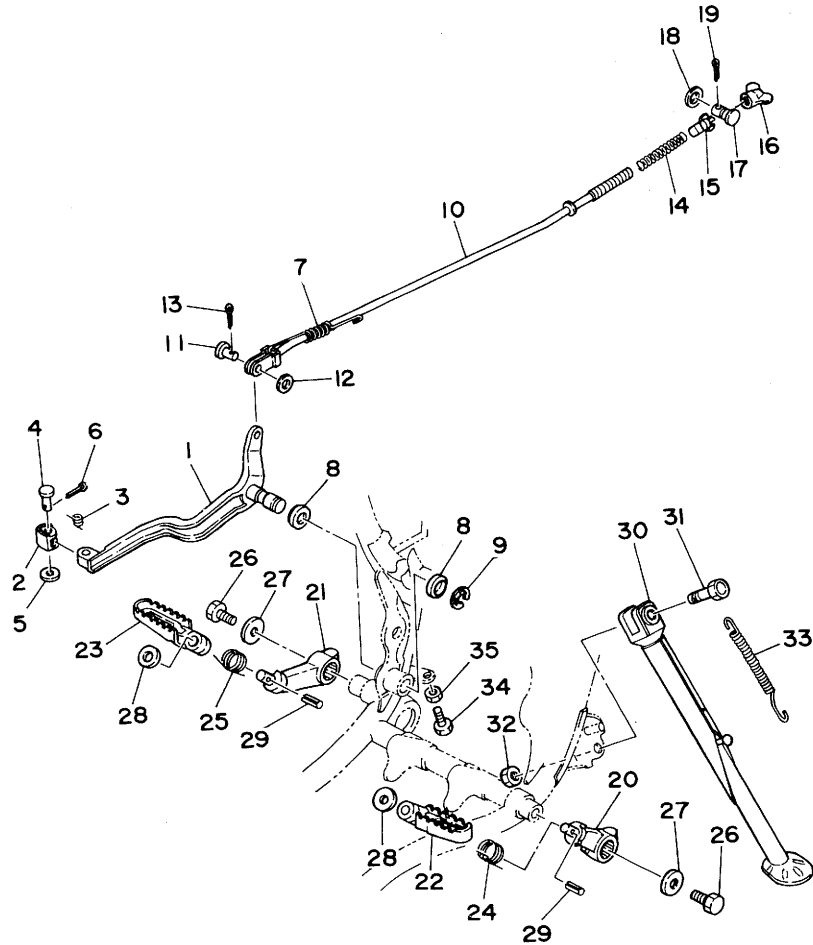

REF. NO.	PART NO.	DESCRIPTION	Q'TY	REMARKS
31	90109-10473	BOLT	1	
32	90185-10037	NUT, self-locking	1	
33	90507-29021	SPRING, tension	1	
34	97301-06020	BOLT	1	
35	95301-06700	NUT	1	

FWD

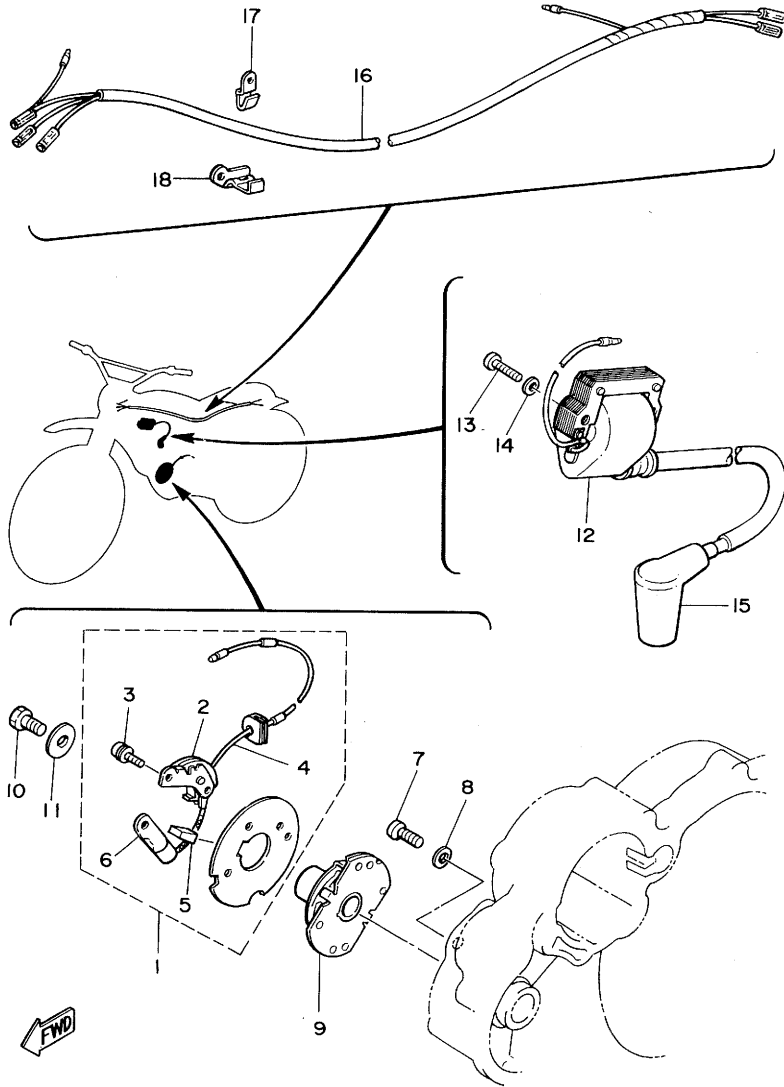
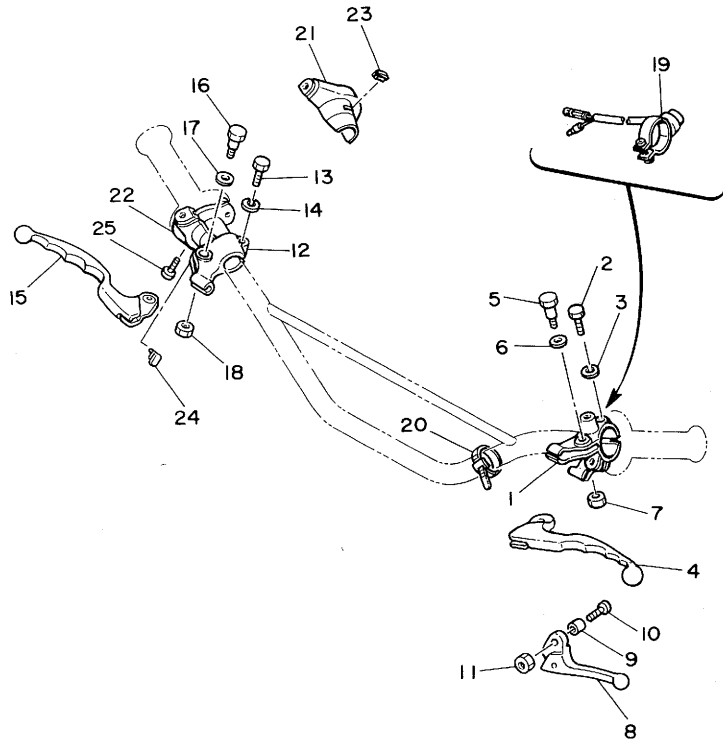

FIG. 29 ELECTRICAL 1

REF. NO.	PART NO.	DESCRIPTION	Q'TY	REMARKS
1	583-81620-50	BREAKER PLATE ASSY	1	
2	583-81621-50	•CONTACT BREAKER ASSY	1	
3	583-81645-50	•SCREW	3	
4	583-81615-50	•WIRE, lead	1	
5	583-81631-50	•LUBRICATOR	1	
6	583-81625-50	•CONDENCER	1	
7	97801-06014	SCREW, Pan head	2	
8	92901-06200	WASHER, Plain	2	
9	583-81653-50	GOVERNOR ASSY	1	
10	97301-06016	BOLT	1	
11	90201-06060	WASHER, Plate	1	
12	583-82310-50	IGNITION COIL ASSY	1	
13	92501-06025	SCREW, Pan head	2	
14	92901-06600	WASHER, Plate	2	
15	437-82370-21	PLUG CAP ASSY	1	
16	2Y0-82590-00	WIRE HARNESS ASSY	1	
17	90465-06086	CLAMP	1	
18	90465-10090	CLAMP	1	

FIG. 30 HANDLE SWITCH•LEVER



REF. NO.	PART NO.	DESCRIPTION	Q'TY	REMARKS
1	583-82911-01	HOLDER, lever 1	1	
2	97301-06022	BOLT	1	
3	92901-06100	WASHER, sPrinG	1	
4	2H0-83912-20	LEVER 1	1	low gloss black
5	90109-06410	BOLT	1	
6	90201-08083	WASHER, Plate	1	
7	95601-06100	NUT, u	1	
8	583-83981-00	LEVER, decomPression	1	
9	583-83913-00	COLLAR, decomPression lever	1	
10	98501-05018	SCREW, Pan head	1	
11	95601-05100	NUT, u	1	
12	233-82921-31	HOLDER, lever 2	1	
13	97301-06022	BOLT	1	
14	92901-06100	WASHER, sPrinG	1	
15	2H0-83922-20	LEVER 2	1	low gloss black
16	90109-06410	BOLT	1	
17	90201-08083	WASHER, Plate	1	
18	95601-06100	NUT, u	1	
19	2Y0-83976-00	SWITCH, handle 1	1	
20	437-83936-00	BAND, switch cord	2	
21	583-83986-00	CASE, switch uPPer	1	
22	583-83987-00	CASE, switch lower	1	
23	583-83956-00	CAP 1	1	
24	583-83957-00	CAP 2	1	
25	98501-05018	SCREW, Pan head	2	

FWD

ALTERNATE PARTS

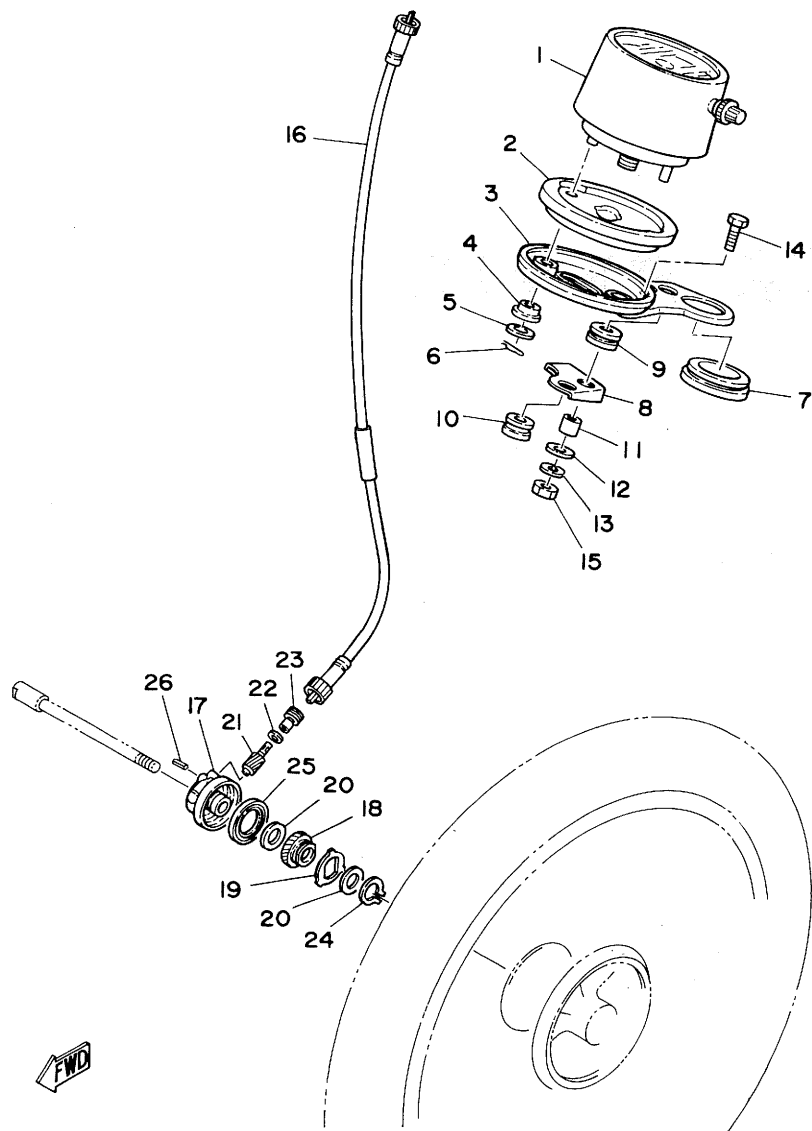
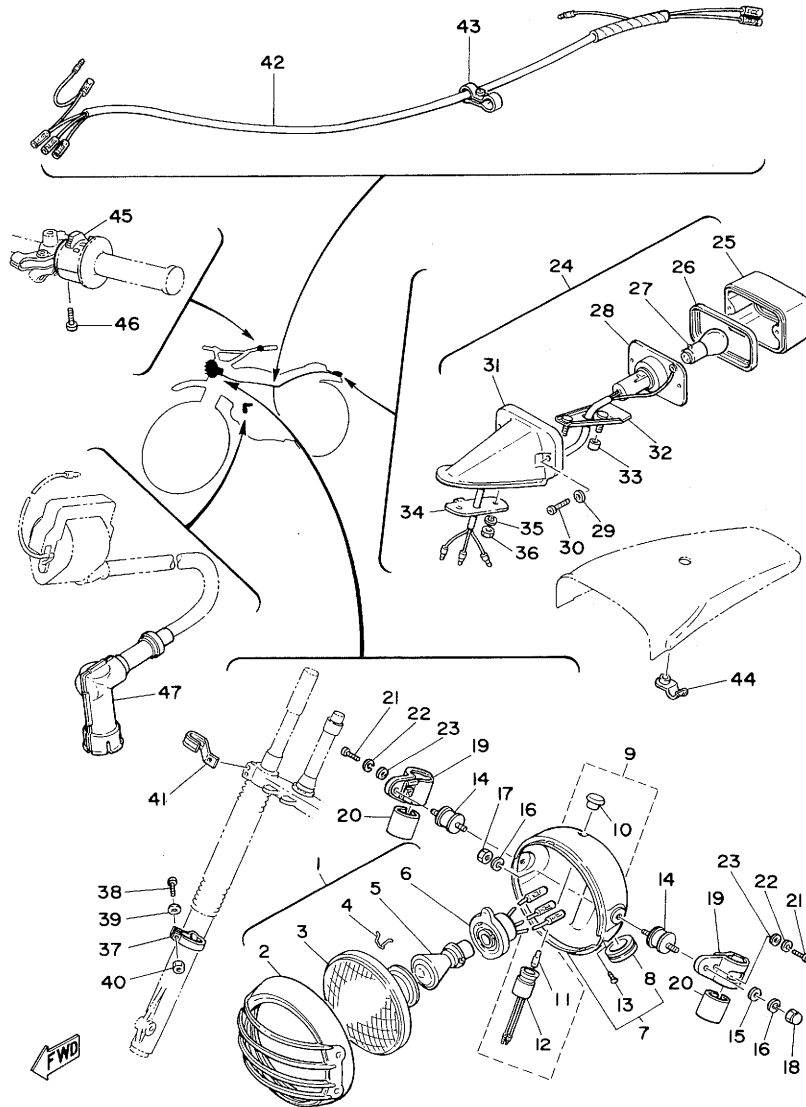

FIG. 31 TACHOMETER

REF. NO.	PART NO.	DESCRIPTION	Q'TY	REMARKS
1	1K7-83510-30	SPEEDOMETER ASSY	1	UR
	1K7-83510-10	SPEEDOMETER ASSY	1	UR
2	1K7-83513-00	DAMPER	1	
3	1K7-83519-01	BRACKET, meter	1	
4	1M1-83526-00	DAMPER 2	2	
5	1E6-83524-60	WASHER, sPecial	2	
6	90468-12007	CLIP	2	
7	1K7-83592-00	DAMPER	1	
8	2Y0-83514-00	PLATE, fitting	1	
9	90480-14052	GROMMET	1	
10	90480-15168	GROMMET	1	
11	90387-06216	COLLAR	1	
12	90201-06067	WASHER, Plate	1	
13	92901-06100	WASHER, sPring	1	
14	97301-06020	BOLT	1	
15	95301-06600	NUT	1	
16	2Y0-83550-00	SPEEDOMETER CABLE ASSY	1	
17	1W2-25191-00	HOUSING, gear	1	
18	1W2-25135-00	GEAR, drive	1	
19	1K7-25149-00	CLUTCH, meter	1	
20	90201-22283	WASHER, Plate	2	
21	1W2-25138-00	GEAR, meter	1	
22	102-18416-00	SHIM, rod	1	
23	306-25136-00	BUSH	1	
24	93410-22014	CIRCLIP	1	
25	93105-40020	OIL SEAL	1	
26	91609-20014	PIN, sPring	1	

FIG. 32 HEADLIGHT, TAILLIGHT



REF. NO.	PART NO.	DESCRIPTION	Q'TY	REMARKS
1	493-84110-61	HEADLIGHT UNIT ASSY	1	
2	493-84115-60	•RIM, headlight	1	
3	434-84120-60	•LENS ASSY	1	
4	195-84324-00	•SPRING, reflector	3	
5	214-84114-60	•BULB (6V-35/35W)	1	
6	434-84112-60	•SOCKET	1	
7	434-84130-61-33	BODY ASSY, headlight	1	yamaha black
8	150-84153-00	•GROMMET, wireherness	1	
9	214-84101-61	PILOT LIGHT ASSY	1	
10	256-84357-61	•BODY, Pilot light	1	
11	104-83517-10	•BULB (6V-1.5W)	1	
12	214-84150-61	•SOCKET CORD ASSY 2	1	
13	90152-05005	SCREW, countersunk	1	
14	1K7-84137-60	BOLT, sPecial	2	
15	92901-08600	WASHER, Plate	2	
16	92901-08100	WASHER, sPring	4	
17	95301-08600	NUT	2	
18	95301-08800	NUT, crown	2	
19	1K7-84118-60-33	STAY, headlight 1	2	
20	1K7-84136-61	DAMPER, headlight stay	2	
21	92501-06018	SCREW, Pan head	2	
22	92901-06100	WASHER, sPring	2	
23	92901-06600	WASHER, Plate	2	
24	434-84500-64	TAILLIGHT ASSY	1	
25	434-84521-69	•LENS, taillight	1	
26	434-84515-61	•RIM, taillight	1	
27	122-84514-30	•BULB (6V-17/5.3W)	1	
28	434-84517-61	•CORD, taillight	1	
29	434-84522-62	•WASHER	2	
30	434-84524-61	•SCREW, lens fitting	2	

FIG. 32 HEADLIGHT, TAILLIGHT

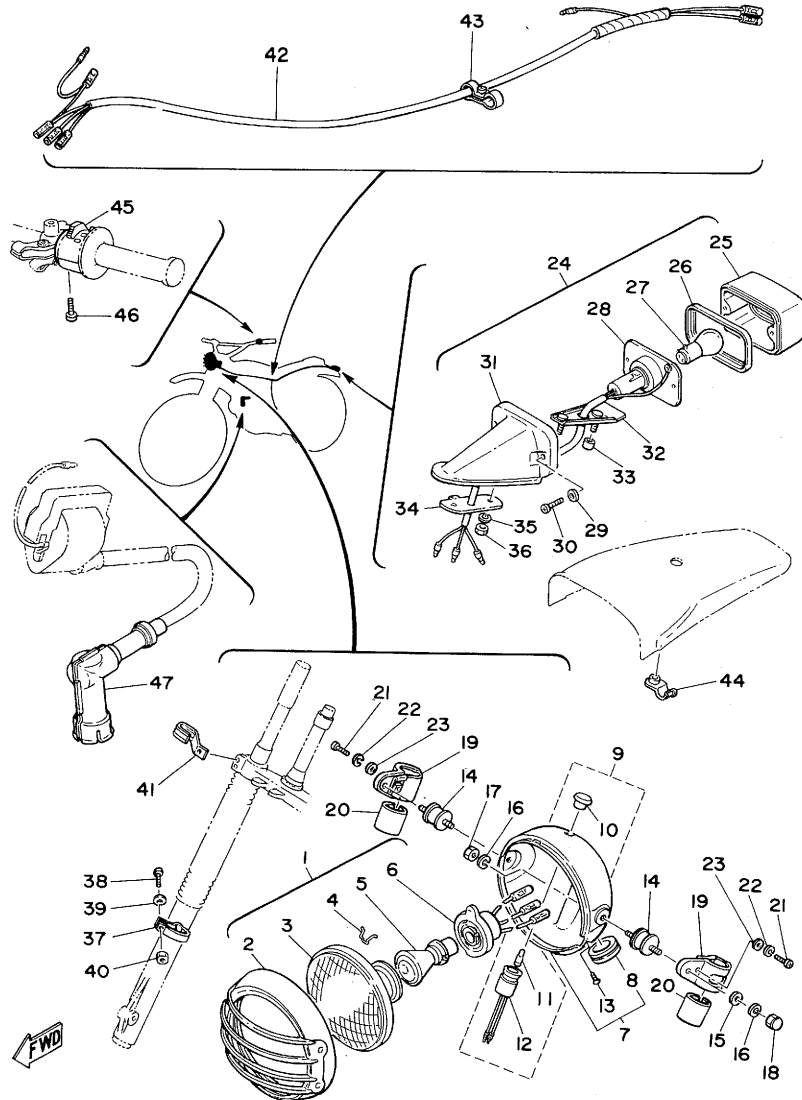

REF. NO.	PART NO.	DESCRIPTION	Q'TY	REMARKS
31	434-84519-64	•BRACKET, taillight	1	
32	434-84511-63	•BASE, taillight	1	
33	434-84557-60	•COLLAR	2	
34	434-84525-01	WASHER, sPecial	1	
35	92901-05100	WASHER, sPring	1	
36	95301-05600	NUT	2	
37	1W2-23318-00	HOLDER, cable 1	1	
38	98501-05018	SCREW, Pan head	1	
39	92901-05600	WASHER, Plate	1	
40	95301-05600	NUT	1	
41	90462-08024	CLAMP	1	
42	2Y0-82590-90	WIRE HARNESS ASSY	1	
43	583-90274-00	CLAMP	1	
44	90462-08036	CLAMP	1	
45	1T1-83973-00	SWITCH, handle 3	1	
46	98501-05022	•SCREW, Pan head	2	
47	512-82370-10	PLUG CAP ASSY	1	

INDEX

NUMERICAL INDEX

PART NO.	REF. NO.	PART NO.	REF. NO.
2Y0-W2473-00	24- 1	583-13113-00	6-30
		583-13161-01	6-33
2Y0-11110-00-R4	1- 1	583-13310-01	6-14
583-11127-00	1- 5	583-13314-00	6- 3
	2- 8	583-13316-02	6- 8
583-11133-11	1- 4	583-13320-00	6-15
583-11150-00	3-14	583-13324-00	6- 1
583-11181-01	2- 1	583-13325-00	6- 2
583-11186-00-R4	1-19	583-13336-02	6-12
1T1-11197-00	1-16	583-13411-00	6-16
214-11198-01	6-21	583-13414-00	6-17
583-11310-00	2- 6	583-13417-01	6-18
583-11351-00	2-11	2H0-13440-90	6-22
583-11400-00	3- 1	583-13447-00	6-23
583-11412-00	3- 2	583-13464-00	6-36
583-11422-00	3- 3	583-13465-02	6-40
583-11533-00	5-11	583-13556-01	8- 3
583-11536-00	3-15	256-13564-00	8- 2
583-11549-00	5-10	583-13565-01	8- 1
583-11610-01	3-19	2Y0-14101-00	7- 1
583-11610-11	3-19	583-14112-40	7-16
583-11610-21	3-19	500-14115-00	7-15
583-11610-31	3-19	1T1-14116-02	7-17
583-11610-41	3-19	2J2-14121-00	7-51
583-11631-02-95	3-18	525-14123-00	7-37
583-11631-02-96	3-18	583-14131-01	7-42
583-11633-00	3-20	2J2-14133-00	7-49
583-11635-02	3-18	127-14134-00	7-35
583-11636-02	3-18	500-14135-00	7-53
583-11637-02	3-18	164-14137-00	7-18
583-11638-02	3-18	737-14137-00	7-58
583-11651-00	3- 6	583-14141-52	7- 3
583-11681-00	3- 4	193-14142-30	7- 2
2J2-12111-00	4- 1	137-14143-46	7- 5
256-12116-01	4- 5	137-14143-48	7- 5
256-12117-01	4- 7	137-14143-50	7- 5
341-12118-00	4- 8	354-14147-00	7-36
341-12119-02	4- 6	558-14147-00	7-14
583-12121-00	4- 2	583-14148-00	7- 4
583-12151-00	4- 9	583-14158-00	7-32
583-12156-01	4-10	583-14171-01	7-52
583-12159-00	4-11	802-14173-00	7-56
583-12171-01	5- 1	583-14174-00	7-55
583-12176-00	5- 2	583-14175-01	7-59
583-12212-00	5-25	1E6-14181-12	7-11
583-12217-00	5-19	583-14184-00	7-10
583-12231-00	5-14	583-14185-00	7- 8
2H0-12232-00	5-21	127-14186-00	7- 9
341-12241-03	5-16	168-14190-28	7- 6
583-12247-00	5-17	214-14195-00	7- 7
1T1-12279-00	5- 5	432-14197-00	7-66
583-12283-00	1-27	583-14197-01	7-65
583-12288-00	1-23	583-14215-00	7-45

PART NO.	REF. NO.	PART NO.	REF. NO.
583-14216-00	7-27	583-15316-00	10-20
583-14239-01	7-43	583-15317-01	10-21
583-14245-01	7-50	583-15346-00	10- 9
583-14264-00	7-38	583-15347-00	10-10
583-14265-00	7-44	137-15353-00	16-13
583-14274-00	7-22	583-15358-00	10- 8
583-14291-00	7-19	583-15371-00	10- 3
583-14292-00	7-28	363-15381-00	10-15
583-14386-00	7-25	583-15383-00	10-23
583-14411-01	8- 6	583-15411-00	11- 1
583-14421-00	8-11	2J2-15417-00	11-17
583-14422-00	8- 7	583-15421-00	11- 5
583-14431-00	8-19	583-15425-00	11-12
1T1-14437-00	8-18	583-15426-00	10-25
1T1-14441-00	8-20	583-15431-02-98	11- 7
583-14451-00	8-15	583-15451-00	11- 2
583-14453-00	8-22	583-15457-00	11-18
583-14468-01	8- 2	583-15462-00	11-11
583-14472-00	8-17	583-15466-00	10-26
583-14485-00	8-21	1T1-15618-00	13- 7
583-14536-00	7-31	1T1-15620-00	13- 1
583-14558-00	7-24	583-15621-00	13- 2
583-14562-00	7-17	583-15631-00	13-31
2J2-14571-00	7-39	583-15641-00	13-16
583-14573-00	7-46	583-15651-00	13-28
583-14589-00	7-63	583-15661-00	13- 9
583-14592-00	7-29	434-15668-00	13-26
583-14594-00	7-60	583-15671-00	13-10
812-14594-00	7-48	583-15674-00	13-24
583-14597-00	7-30	363-15676-00	13-12
1T1-14611-02	9- 1	583-15676-00	13-18
807-14617-00	28-12	363-15686-00	13-25
1T1-14628-00	9- 2	583-16111-00	14-11
1T1-14711-32	9-12	214-16119-00	14-16
1T1-14711-50	9-13	583-16150-00	14- 2
1T1-14714-01	9-10	363-16154-00	14-15
1T1-14718-00	9-18	170-16164-00	14- 3
1T1-14747-01	9-23	583-16301-00	14- 1
1T1-14752-01	9-15	583-16321-00	14- 5
1T1-14755-01	9-28	360-16325-00	14- 6
1E6-14766-01	9- 5	364-16343-00	14-28
	9-21	583-16344-00	14-29
	9- 4	498-16351-00	14- 7
	9-20	174-16356-00	14-18
	9-14	583-16357-01	14-19
	9-11	583-16371-00	14- 4
	9-27	583-16382-00	14-20
	7-57	214-16389-00	14-21
	7-23	583-17121-00	15- 4
	7-26	583-17131-02	15- 5
	7-68	583-17141-00	15- 6
	7-67	583-17151-01	15- 7
	10- 1	583-17211-00	15-14

NUMERICAL INDEX

PART NO.	REF. NO.	PART NO.	REF. NO.
583-17221-00	15-15	431-22151-03	20- 7
583-17231-01	15-16	2Y0-22153-00-33	20-12
583-17241-00	15-17	2N0-22178-00	20-25
583-17251-01	15-18	2Y0-22179-00	20-24
583-17411-01	15- 1	2Y0-22210-00	20-34
2H0-17421-00	15-12	1T1-22211-00	20-35
168-17428-01-05	15- 2	1T1-22212-00	20-36
214-17461-40	15-29	583-22214-00	20-37
214-17461-50	15-29	2Y0-22311-01-33	20-18
214-17461-60	15-29	2Y0-23101-00	21- 1
2J2-18103-00	17- 1	1U6-23111-M1	21-23
2Y0-18111-00-33	17-13	240-23114-00	21-22
1W6-18113-00	17-15	1T2-23118-00	21-21
434-18122-00	16-20	122-23119-01	21-35
278-18127-00	17- 7	2Y0-23124-00	21-13
583-18131-00	17-12	2W6-23126-00	21- 2
2J2-18141-00	16- 5	122-23129-00	21-34
498-18151-03	16-22	2W6-23136-00	21- 3
1W6-18162-00	17-14	2Y0-23141-00	21-19
102-18416-00	31-22	583-23142-00	21-20
363-18511-00	16-15	1G8-23144-L1	21- 8
364-18511-00	16-14	1K7-23145-00	21- 4
363-18531-00	16-17	509-23146-L0	21- 5
363-18535-00	16-18	1W1-23148-L0	21- 9
2Y0-18540-00	16- 1	1W1-23153-L0	21- 7
1J7-18547-00	16-10	1W1-23156-L0	21- 6
434-18561-00	16- 3	509-23158-L0	21-32
2Y0-21110-00-33	18- 1	1U6-23168-M0	21-24
583-21315-00	18-19	1W1-23168-L0	21-10
583-21316-00	18-11	2Y0-23170-00	21-12
1T1-21317-00	18-15	2Y0-23173-00	21-11
1T1-21471-01	18-21	278-23181-50	21-33
3H6-21511-00	19- 1	2N6-23191-00	21-16
322-21541-00	19-14	509-23194-L0	21-18
583-21611-00	19- 7	1W1-23317-01	21-28
1T1-21620-00	19-17	3R4-23317-00	22-10
322-21639-00	19-13	1W1-23318-L0	21-14
2Y0-21711-10-33	18-25	1W2-23318-00	32-37
583-21714-00	18-26	2Y0-23340-00-33	21-25
	18-32	1T2-23389-00	22-11
2Y0-21721-10-33	18-31	1W1-23389-00	21-29
583-21746-00	19-18	322-23395-00	21-37
583-21747-00	18-29	122-23411-00	22-15
	18-35	156-23411-00	22- 1
	18-41	122-23412-00	22-16
583-21755-00	18-43	156-23412-00	22-13
583-21756-00	18-37	2Y0-23416-00	22-18
583-21771-00	18-30	1W1-23435-01-98	22- 3
2Y0-21786-10	18-36	1E6-23441-00-98	22- 4
2Y0-21787-10	20- 1	164-23462-00	22- 2
2Y0-22110-01-35	20- 4	583-23469-00	22-12
483-22124-00	20- 6	583-23485-00	21-36
2K8-22129-00	20- 9	431-23486-02	21-38
583-22141-01	20- 9		

NUMERICAL INDEX

PART NO.	REF. NO.	PART NO.	REF. NO.
509-23489-LO	21-15	583-26241-00	27- 5
2Y0-24110-00-02	23- 1	583-26242-00	27- 2
322-24161-00	23- 3	2H0-26243-00	27- 3
583-24181-00	23-20	1W1-26249-00	27- 4
583-24182-00	23-23	2H0-26301-00	27- 6
2Y0-24240-00	23- 2	583-26331-00	27-20
322-24500-02	23- 4	2Y0-26355-00	27-15
2A6-24611-00	23- 8	1W1-26341-01	27- 9
1W1-24612-00	23- 9	156-26347-00	27-14
583-24724-00	24- 5	583-26352-00	27-21
2Y0-24731-00	24- 2	382-26372-01	27-10
1T1-24738-00	24- 4		27-16
2Y0-24748-00	24- 3	341-26397-01	27-17
2W6-25104-01	25-15	583-26398-00	27- 7
1K7-25111-10-98	25- 1	2Y0-27211-00-R4	28- 1
146-25116-00	25- 3	2Y0-27231-00	28-10
322-25118-00	25-24	498-27235-00	28- 8
1W1-25121-01-98	25- 7	1W2-27237-00	28-17
322-25130-00	25- 8	1W2-27239-00	28-15
1W2-25135-00	31-18	1W2-27242-00	28- 2
306-25136-00	31-23	2Y0-27311-00-33	28-30
1W2-25138-00	31-21	583-27411-00	28-22
1K7-25149-00	31-19	2Y0-27412-00-33	28-20
1E2-25151-00	26-11	583-27421-00	28-23
322-25151-00	25-10	2Y0-27422-00-33	28-21
322-25155-00	25-11	583-28100-10	18-48
137-25159-00	25-13	648-45533-00-03	20- 5
1W1-25181-00	25-20	583-81300-50	12- 1
1W2-25191-00	31-17	583-81309-50	12- 3
1T1-25194-00	25-19	583-81311-50	12- 4
431-25304-01	26-17	583-81313-50	12- 6
483-25311-13-98	26- 1	583-81315-50	12- 8
483-25315-00	26- 6	583-81328-50	12- 9
483-25317-01	26- 2	583-81345-50	12- 5
1W4-25321-00-98	26- 8		12- 7
1W4-25330-01	26- 9	583-81346-50	12-10
148-25353-00	26-15	583-81350-50	12- 2
2Y0-25355-00	26-13	583-81615-50	29- 4
148-25359-00	26-12	583-81620-50	29- 1
431-25367-00	26-25	583-81621-50	29- 2
2K8-25381-00	26-32	583-81625-50	29- 6
2Y0-25388-00	26-29	583-81631-50	29- 5
1T1-25394-01	26-21	583-81645-50	29- 3
583-25412-00	26-23	583-81653-50	29- 9
583-25440-10	26-22	583-82310-50	29-12
583-25442-10	26-22	437-82370-21	29-15
583-25444-10	26-22	512-82370-10	32-47
583-25446-10	26-22	2Y0-82590-00	29-16
583-25448-10	26-22	2Y0-82590-90	32-42
583-25450-10	26-22	583-82911-01	30- 1
583-25452-10	26-22	233-82921-31	30-12
583-25454-10	26-22	1K7-83510-10	31- 1
2Y0-26111-00	27- 1	1K7-83510-30	31- 1

PART NO.	REF. NO.	PART NO.	REF. NO.
1K7-83513-00	31- 2	583-83956-00	30-23
2Y0-83514-00	31- 8	583-83957-00	30-24
104-83517-10	32-11	1T1-83973-00	32-45
1K7-83519-01	31- 3	2Y0-83976-00	30-19
1E6-83524-60	31- 5	583-83981-00	30- 8
1M1-83526-00	31- 4	583-83986-00	30-21
2Y0-83550-00	31-16	583-83987-00	30-22
1K7-83592-00	31- 7	214-84101-61	32- 9
2H0-83912-20	30- 4	493-84110-61	32- 1
583-83913-00	30- 9	434-84112-60	32- 6
2H0-83922-20	30-15	214-84114-60	32- 5
437-83936-00	6-43	493-84115-60	32- 2
	30-20	1K7-84118-60-33	32-19
	30-23	434-84120-60	32- 3
	30-24	434-84130-61-33	32- 7
	32-45	1K7-84136-61	32-20
	30-19	1K7-84137-60	32-14
	30- 8	214-84150-61	32-12
	30-21	150-84153-00	32- 8
	30-22	195-84324-00	32- 4
	32- 9	256-84357-61	32-10
	32- 1	434-84500-64	32-24
	32- 6	434-84511-63	32-32
	32- 5	122-84514-30	32-27
	32- 2	434-84515-61	32-26
	32-19	434-84517-61	32-28
	32- 3	434-84519-64	32-31
	32-20	434-84521-69	32-25
	32-14	434-84522-62	32-29
	32-12	434-84524-61	32-30
	32- 8	434-84525-01	32-34
	32- 4	434-84557-60	32-33
	32-10	90101-06291	25-12
	32-24		26-14
	32-32	90101-06304	24- 6
	32-27	90101-08034	26-30
	32-26	90101-10303	5- 4
	32-28	90105-08064	18- 6
	32-29	90105-08066	18-20
	32-30	90105-10039	18- 2
	32-34		
	32-33		
	25-12		
	26-14		
	24- 6		
	26-30		
	5- 4		
	18- 6		
	18-20		
	18- 2		

PART NO.	REF. NO.	PART NO.	REF. NO.
90105-10050	18- 4	90109-06410	30- 5
90105-10051	18- 7		30-16
90105-10063	18- 3		30-16
90105-10104	20-39		1-13
90105-14060	22- 9	90109-06418	1-13
	30- 5		1-25
	30-16		6-26
	30-17		21-26
	9-31		20-38
	9-27		28-31
	1-10		90201-09572
	9-35		90201-10119
	3-17		90201-10124
	6- 5		90201-10126
	1- 8		90201-10141
	18-10		90201-10590
	20-31		90116-08218
	2- 9		90116-10087
	90387-06216		2-12
	31-11		90201-10591
	8-36		2- 2
	19- 3		90201-10639
	9-22		2- 3
	23-12		90201-12166
	25-23		2- 5
	26-26		90201-12172
	26-27		3-10
	15-27		90201-12593
	6-34		28-18
	6-29		90201-12631
	1-14		17- 2
	1-26		16-12
	6-35		90201-14215
	18-46		90201-14220
	10-13		5-22
	11-20		32-13
	10-28		90201-15234
			14- 9
			90201-17255
			13-29
			14-27
			90430-08119
			15-10
			90430-09121
			15-23
			90430-10027
			13-23
			90430-10148
			15-21
			10-28
			31-20
			90430-14043
			13-14
			90430-22123
			15- 8
			90430-27124
			18-38
			9- 8
			90445-07039
			10-17
			90445-09111
			23-10
			90445-11288
			9- 6
			90445-11289
			18- 9
			90445-11418
			14-13
			90462-07114
			20-11
			90460-22083
			19-12
			90460-58015
			23-17
			8- 5
			90460-61063
			9-24
			90460-71017
			9-25
			17- 5
			90462-08024
			17- 8
			90462-08036
			15-30
			90465-05075
			14-22
			10-18

NUMERICAL INDEX

PART NO.	REF. NO.	PART NO.	REF. NO.
90201-06073	23-13	90240-06057	17-16
90201-06407	20-21	90240-08012	27-11
90201-06557	18-24	90240-08051	28-11
90201-06571	19-10	90250-08017	16-16
90201-08083	27-12	583-90274-00	32-43
	30- 6	90280-05013	3- 9
	30-17	90282-07021	14-12
	9-31	90338-09012	27-22
	9-27	90338-09066	15-13
	1-10	90338-18067	1-12
	9-35	90340-10003	10-29
	3-17		11-21
	6- 5		
	1- 8	90340-14009	6-20
	18-10	90340-14038	1-17
	20-31	90381-17027	26-28
	2- 9	90387-06216	31-11
	5- 6	90387-06388	19- 3
	28-27	90387-07391	8-26
	6- 7	90387-08572	9-22
	14-30	90387-09506	23-12
	3-10	90387-15535	25-23
	28-18	90387-17650	26-26
	28-28	90387-17651	26-27
	20-30	90387-25507	15-27
	17-10	90401-08038	6-34
	3-16	90430-05126	6-29
	13- 5	90430-06014	1-14
	13-29		1-26
	14-27		6-35
	15-10		18-46
	15-23		90430-09121
	13-23		10-13
	15-21		90430-10027
	31-20		11-20
	13-14		90430-10148
	15- 8		10-28
	15-19		
	13-22		
	16- 8		
	9-30		
	9- 6		
	18- 9		
	14-13		
	20-11		
	19-12		
	23-17		
	9-24		
	9-25		
	17- 5		
	17- 8		
	15-30		
	14-22		
	31-12		

NUMERICAL INDEX

PART NO.	REF. NO.	PART NO.	REF. NO.
90465-05084	10-14	91316-06030	2-14
90465-06077	6-44		11-14
90465-06086	29-17	91316-06035	10- 4
90465-08076	11-22		11- 4
90465-10090	29-18		11- 6
90467-10008	18-40	91316-06040	11-15
	23- 6	91316-06045	10- 5
90467-11010	23- 7	91316-06055	1-11
90468-12007	31- 6		10- 7
90468-15009	27- 8	91316-06060	6-25
90480-12188	20-19	91316-06065	10- 6
90480-14052	31- 9	91401-10010	14-23
90480-14102	8-25	91401-20012	17-20
90480-14198	19- 2		27-13
90480-15168	31-10		28- 6
90480-22054	23-16		28-13
90480-22177	23-11	91401-25022	28-19
90501-05378	6-32	91401-30030	25-22
90501-10062	16-11	91609-20014	31-26
90501-10245	28-14	91609-25018	18-27
90501-12081	13- 4		18-33
90501-14095	5-20	91609-30020	28-29
90501-23143	13-11	91701-06022	28- 4
90501-23391	14- 8	91810-05016	10- 2
90501-31454	4- 3	91830-22016	11-16
90501-44455	4- 4	91830-24016	1- 3
90506-16036	25- 9		2-10
90506-20128	28- 7	341-92090-60	21-17
90507-20002	26-10	92501-06012	7-61
90507-29021	28-33		10-19
90508-08334	16-21	92501-06015	5-15
90508-12279	14-24		7-13
90508-14352	28- 3	92501-06018	6-10
90508-16303	1-24		10-27
90508-16351	17-17		19-11
90508-26276	28-25		32-21
90508-26277	28-24	92501-06025	29-13
90508-32052	17- 4	92501-06030	6- 9
90508-32280	13-19	92502-06016	12-11
90508-35387	20-29	92701-06015	10-24
90560-05001	20-20	92901-04100	7-21
90560-15116	25- 2		7-34
90560-25153	14-10	92901-05100	7-41
90560-25154	13-20		8- 9
91316-06012	6-39		20-23
91316-06015	6-38		20-28
	6-42		23-22
91316-06018	1-21		32-35
91316-06020	6-19	92901-05600	8-10
91316-06025	1-15		32-39
	8- 4	92901-06100	7-12
	11- 3		7-62
	11-19		8-13

NUMERICAL INDEX

PART NO.	REF. NO.	PART NO.	REF. NO.	PART NO.	REF. NO.	PART NO.	REF. NO.	PART NO.	REF. NO.
92901-06100	8-28	93210-10197	6-37	93603-17070	6- 4	97301-08016	23-18		
	9-17	93210-12095	10-22	93604-08071	16- 7	97311-10016	28-26		
	17- 6	93210-12152	5-18	93604-16092	5- 3	97321-06010	9-16		
	18-23	93210-14299	1- 2	93604-18100	16- 2	97321-06014	19- 8		
	19- 6	93210-15171	6-41	93604-22050	6-13		19-20		
	19- 9	93210-22298	15-28	94130-21510	25-16	97321-06016	13-27		
	19-15	93210-32172	5-24	94146-18511	26-18	97321-06020	17-21		
	19-21	93210-35173	11-13	94227-21101	25-17	97321-06030	23-14		
	20-14	93210-49296	1-20	94240-18098	26-19	97321-08016	24- 7		
	20-17	93210-64297	6-24	94327-21071	25-18	97321-08020	9-33		
	23-15	93210-69355	21-39	94340-18069	26-20	97321-08025	18-12		
	30- 3	93210-92295	2- 7	94416-21104	25-14		18-16		
	30-14	93304-20501	15- 3	94421-18105	26-16	97321-08030	13- 8		
	31-13	93306-00502	5- 7	94500-02106	5-12	97701-50110	18-42		
	32-22	93306-00506	5- 8	94585-20104	26-35	97801-06014	29- 7		
92901-06200	17-19	93306-20203	25- 4	94600-02001	5-13	98501-04012	7-20		
	29- 8	93306-20205	25- 5	94685-20011	26-36	98501-04014	7-33		
92901-06600	8-14	93306-20310	26- 3	94701-00117	1-22	98501-05012	7-40		
	17-18	93306-20316	26- 4	95301-05600	32-36		8- 8		
	20-15	93306-30517	15-25		32-40		23-21		
	28- 5	93306-30616	3- 7	95301-06600	17- 3	98501-05018	30-10		
	29-14	93306-30702	3-13		31-15		30-25		
	32-23	93301-635A5	3- 5	95301-06700	28-35		32-38		
92901-08100	7-47	93311-42012	15-11	95301-08600	32-17	98501-05022	32-46		
	9-32	93313-32008	15-24	95301-08700	26-31	98501-05040	20-27		
	9-34	93315-11720	14-25	95301-08800	32-18	98701-05012	10-16		
	18-13	93315-23208	16- 9	95301-10700	20-33		16- 4		
	18-17	93317-22208	20- 3	95303-06800	19-16	98906-06010	9- 3		
	21-30	93342-22205	20- 2	95303-08600	1- 9		9-19		
	23-19	93410-10025	6- 6	95311-08600	21-31				
	24- 8	93410-17008	13-30	95601-05100	30-11				
	32-16	93410-19015	13-13	95601-06100	30- 7				
92901-08600	18-14	93410-20038	15-22		30-18				
	18-18	93410-22014	31-24	95601-08100	9-29				
	24- 9	93410-25010	13-21	95601-16100	20-10				
	32-15	93410-30012	16- 6	95621-08615	9- 7				
92901-12100	3-11	93420-25002	11- 9	95701-08100	22- 8				
92901-16100	26-33	93430-07012	16-23	95801-08012	18-45				
93101-14089	11- 8	93430-08006	16-19	95821-08035	22- 5				
93102-15147	11-10	93430-10016	13- 6	95821-08040	22- 6				
93102-17148	14-26	93430-12009	17-11	95821-08055	22- 7				
93102-20009	25- 6	93430-15023	28- 9	97301-05014	20-22				
93102-25030	26- 5	93440-25019	13-17	97301-06014	18-22				
93102-25064	13-32	93440-25020	13-15	97301-06016	20-16				
93102-30145	3- 8		15- 9		29-10				
93102-35180	15-26		15-20	97301-06018	20-13				
93104-11038	6-11	93440-47044	5- 9	97301-06020	8-12				
93104-12054	1-28	93450-22027	3-21		28-34				
93104-14044	20-26	93501-04011	22-14		31-14				
93105-40020	31-25	93501-08001	7-64	97301-06022	30- 2				
93108-35004	20- 8	93503-08007	6-31		30-13				
93109-14010	17- 9	93503-16010	22-17	97301-06025	8-27				
93210-07135	6-27	93507-32009	13- 3	97301-06030	19- 5				

PARTS NAME INDEX

DESCRIPTION	REF. NO.
*	21-17
ABSORBER 3	1- 5
*	2- 8
ARM, brake	28- 1
ARM, shift	17-13
ARM, tensioner	20-24
ARM, valve rocker	4- 9
ARRESTER, spark	9-14
AXLE, drive	15-12
AXLE, kick	13- 9
AXLE, main (14T)	15- 1
AXLE, Push lever	14-20
AXLE, wheel	25-20
*	26-32
BALL	6-31
*	7-64
*	13- 3
*	22-14
*	22-17
BAND	21-15
*	27-17
BAND, boot	21-17
BAND, rim (2.75-21)	25-18
BAND, rim (4.00-18)	26-20
BAND, silencer	9-11
BAND, switch cord	6-43
*	30-20
BAR, shift fork guide 1	16-17
BAR, shift fork guide 2	16-18
BASE, magneto	12- 3
BASE, taillight	32-32
BEARING	20- 2
BEARING (B4205)	15- 3
BEARING (B6005)	5- 7
*	5- 8
BEARING (B6202)	25- 5
BEARING (B6202RS)	25- 4
BEARING (B6203)	26- 4
BEARING (B6203RS)	26- 3
BEARING (B6305)	15-25
BEARING (B6306)	3- 7
BEARING (B6307)	3-13
BEARING, cylindrical	3- 5
*	14-25
*	15-11
*	15-24
*	16- 9
*	20- 3
BODY ASSY, headlight	32- 7
BODY, cap	18-37
*	23- 8
BODY, float chamber 1	7-11
BODY, Pilot light	32-10
BOLT	1-11

PARTS NAME INDEX

DESCRIPTION	REF. NO.
BOLT	1-13
*	1-15
*	1-21
*	1-25
*	2-14
*	5- 4
*	6-19
*	6-25
*	6-26
*	6-38
*	6-39
*	6-42
*	8- 4
*	8-12
*	8-27
*	9-16
*	9-33
*	10- 4
*	10- 5
*	10- 6
*	10- 7
*	11- 3
*	11- 4
*	11- 6
*	11-14
*	11-15
*	11-19
*	13- 8
*	13-27
*	17-21
*	18-12
*	18-16
*	18-22
*	19- 5
*	19- 8
*	19-20
*	20-13
*	20-16
*	20-22
*	20-32
*	20-38
*	21-26
*	23-14
*	23-18
*	24- 6
*	24- 7
*	25-12
*	26-14
*	26-30
*	27-18
*	28-26
*	28-31
*	28-34
*	29-10

PARTS NAME INDEX

DESCRIPTION	REF. NO.
BOLT	30- 2
*	30- 5
*	30-13
*	30-16
*	31-14
BOLT, cap	21-23
BOLT, flange	18-45
*	22- 5
*	22- 6
*	22- 7
BOLT, hexagon socket head	9-26
*	21-33
BOLT, special	32-14
BOLT, stud	2- 2
*	2- 3
*	2- 4
*	2- 5
*	2-12
*	9- 7
*	26- 7
BOLT, union	6-34
BOLT, washer based	18- 2
*	18- 3
*	18- 4
*	18- 6
*	18- 7
*	18-20
*	20-39
*	22- 9
BOOT	21-16
BOOT, sealing	17-12
BOSS, clutch	14- 4
BOSS, kick crank	13- 2
BRACKET 1	7-19
BRACKET, decomp.	1-27
BRACKET, footrest 1	28-20
BRACKET, footrest 2	28-21
BRACKET, meter	31- 3
BRACKET, seat	24- 3
*	24- 4
BRACKET, taillight	32-31
BRACKET, throttle	7-39
BRAKE SHOE COMP.	25- 8
*	26- 9
BREAKER PLATE ASSY	29- 1
BREAKER SHAFT ASSY	3-14
BREATHER	10- 3
BREATHER 1	10- 9
BREATHER 2	10-10
BULB (6V-1.5W)	32-11
BULB (6V-17/5.3W)	32-27
BULB (6V-35/35W)	32- 5
BUSH	31-23

PARTS NAME INDEX

DESCRIPTION	REF. NO.
BUSH 2	20-4
BUSH, solid	26-28
CABLE, brake	27-9
CABLE, clutch	27-15
CABLE, decompression	27-20
CAM, decomp.	1-23
CAMSHAFT	5-1
*	25-10
*	26-11
CAP 1	30-23
CAP 2	30-24
CAP, bolt	22-12
CAP, chain tensioner	5-25
CAP, cleaner case 2	8-7
CAP, front fork	21-24
CAP, plunger	7-55
CARBURETOR ASSY 1	7-1
CASE, air cleaner 1	8-6
CASE, air cleaner 2	8-11
CASE, chain	20-18
CASE, switch lower	30-22
CASE, switch upper	30-21
CHAIN (BF05M-106L)	5-12
CHAIN, drive (DID520DS 104L)	26-35
CIRCLIP	3-21
*	5-9
*	6-6
*	11-9
*	13-6
*	13-13
*	13-15
*	13-17
*	13-21
*	13-30
*	15-9
*	15-20
*	15-22
*	16-6
*	16-19
*	16-23
*	17-11
*	28-9
*	31-24
CLAMP	6-44
*	10-14
*	10-18
*	11-22
*	12-9
*	18-41
*	29-17
*	29-18
*	32-41
*	32-43

PARTS NAME INDEX

DESCRIPTION	REF. NO.
CLAMP	32-44
CLAMP, hose	8-5
*	8-23
*	8-24
*	10-11
*	10-12
CLIP	7-18
*	7-58
*	18-40
*	23-6
*	23-7
*	27-8
*	31-6
CLIP, oil seal	21-6
CLUTCH ASSY	14-1
CLUTCH, meter	31-19
COIL, ignition 1	12-4
COIL, lighting 1	12-6
COLLAR	7-60
*	8-26
*	9-22
*	15-27
*	19-3
*	23-12
*	25-23
*	26-26
*	26-27
*	31-11
*	32-33
COLLAR, decompression lever	30-9
CONDENSER	29-6
CONNECTOR	7-22
CONTACT BREAKER ASSY	29-2
CORD, taillight	32-28
COTTER, valve	4-8
COVER	10-25
COVER, ball race 2	22-18
COVER, cap	11-17
COVER, crankcase 1	11-1
COVER, crankcase 2	11-5
COVER, crankcase 3	11-7
COVER, cylinder head side 2	1-19
COVER, decompression cable	27-21
COVER, double seat	24-2
COVER, dust	28-8
COVER, dust seal	21-9
COVER, generator 2	11-12
COVER, handle lever	27-10
*	27-16
COVER, hub dust	25-24
*	26-25
COVER, kick lever	13-7
COVER, manifold	8-2

PARTS NAME INDEX

DESCRIPTION	REF. NO.
COVER, oil element	6-23
COVER, plunger cap	7-56
COVER, pump	6-8
COVER, shift pedal	17-15
COVER, side (L.H.)	18-25
COVER, side (R.H.)	18-31
COVER, spring	13-12
*	13-18
COVER, strainer	6-18
COVER, thrust 2	20-6
CRANK 1	3-2
CRANK 2	3-3
CRANKCASE ASSY	10-1
CRANKSHAFT ASSY	3-1
CROWN, handle	22-3
CYLINDER	2-6
CYLINDER COMP., front fork	21-12
CYLINDER HEAD ASSY	1-1
DAMPER	5-21
*	18-29
*	18-35
*	31-2
*	31-7
DAMPER 1	19-14
DAMPER 2	19-13
*	31-4
DAMPER, engine mount 1	10-20
DAMPER, headlight stay	32-20
DAMPER, locating 1	23-20
DAMPER, locating 2	23-23
DAMPER, muffler	9-23
DAMPER, seat	24-5
DUCT	8-18
ELEMENT ASSY, oil cleaner	6-22
ELEMENT, air cleaner	8-15
EMBLEM	21-37
EMBLEM 1	23-3
EMBLEM 6	18-30
EMBLEM 7	18-36
FENDER, front	19-1
FENDER, rear	19-7
FLANGE, spacer	26-6
FLANGE, spacer 2	25-3
FLOAT	7-8
FLYWHEEL MAGNETO ASSY	12-1
FOOTREST 1	28-22
FOOTREST 2	28-23
FORK, shift 1	16-14
*	16-15
FRAME COMP	18-1
FRONT FORK ASSY	21-1
FUEL COCK ASSY 1	23-4
FUEL TANK COMP.	23-1

PARTS NAME INDEX

DESCRIPTION	REF. NO.
GASKET	1-14
*	1-18
*	1-26
*	6-21
*	6-29
*	6-35
*	7-31
*	9- 8
*	10-13
*	10-28
*	11-18
*	11-20
*	18-38
*	18-44
*	18-46
*	21-22
*	21-32
GASKET 2	10-26
GASKET, caP	23- 9
GASKET, crankcase cover	11- 2
GASKET, crankcase cover 3	11-11
GASKET, cylinder	2-11
GASKET, cylinder head 1	2- 1
GASKET, drain	16-13
GASKET, drain Plug	21-34
GASKET, float chamber	7-10
GASKET, manifold	8- 3
GASKET, muffler	9-10
GASKET, silencer	9-28
GASKET, strainer cover	6-17
GEAR, drive	31-18
GEAR, drive (21T)	3-15
GEAR, drive (42T)	6- 1
GEAR, kick (29T)	13-16
GEAR, kick Pinion (19T)	13-31
GEAR, meter	31-21
GEAR, Primary drive (30T)	14-11
GEAR, Pump driven (41T)	6- 2
GEAR, sprocket idle (27T)	13-28
GEAR, 1st wheel (33T)	15-14
GEAR, 2nd Pinion (18T)	15- 4
GEAR, 2nd wheel (28T)	15-15
GEAR, 3rd Pinion (21T)	15- 5
GEAR, 3rd wheel (25T)	15-16
GEAR, 4th Pinion (24T)	15- 6
GEAR, 4th wheel (22T)	15-17
GEAR, 5th Pinion (27T)	15- 7
GEAR, 5th wheel (21T)	15-18
GOVERNOR ASSY	29- 9
GRAPHIC SET	23- 2
GRIP (L.H)	27- 5
GRIP (R.H)	27- 2

PARTS NAME INDEX

DESCRIPTION	REF. NO.
GROMMET	8-25
*	19- 2
*	20-19
*	23-11
*	23-16
*	31- 9
*	31-10
GROMMET, wireherness	32- 8
GUARD, chain	20-12
GUIDE, cable	21-29
*	22-11
GUIDE, intake valve (1ST D/S)	1- 4
GUIDE, ratchet wheel	13-24
GUIDE, sPring	20-35
GUIDE, stopPer 1	5-14
GUIDE, stopPer 2	5-16
HANDLEBAR	27- 1
HEADLIGHT UNIT ASSY	32- 1
HOLDER, cable	21-28
*	22-10
HOLDER, cable 1	21-14
*	32-37
HOLDER, handle uPPer	22- 4
HOLDER, lever 1	30- 1
HOLDER, lever 2	30-12
HOSE	10-17
*	18-39
*	18-47
*	18-49
*	23- 5
*	23-10
HOSE, oil 1	6-36
HOSE, oil 2	6-40
HOUSING, gear	31-17
HOUSING, rotor	6-12
HUB, front	25- 1
HUB, rear	26- 1
IGNITION CDIL ASSY	29-12
JET, main (#230)	7- 5
JET, main (#240)	7- 5
JET, main (#250)	7- 5
JET, Pilot (#30.0)	7- 2
JOINT	14-21
JOINT, air cleaner 1	8-22
JOINT, cable	27-14
JOINT, carburetor	8- 1
JOINT, chain	5-13
*	26-36
KEY, straight	14-12
KEY, woodruff	3- 9
KICK CRANK ASSY	13- 1
KNOB, side cover 1	18-26
*	18-32

PARTS NAME INDEX

DESCRIPTION	REF. NO.
LEAD WIRE ASSY	12- 8
LENS ASSY	32- 3
LENS, taillight	32-25
LEVER	7-46
LEVER 1	30- 4
LEVER 2	30-15
LEVER, camshaft	26-13
LEVER, camshaft 1	25-11
LEVER, decomPression	30- 8
LEVER, shift 2	16-20
LEVER, shift 3	16-22
LEVER, starter 1	7-59
LEVER, throttle valve	7-28
LUBRICATOR	29- 5
MUD GUARD COMP.	19-17
MUFFLER 1	9-12
*	9-13
NEEDLE	7-17
NEEDLE VALVE ASSY	7- 6
NET, filter	18-43
NOZZLE, main	7- 3
NUT	1- 6
*	1- 7
*	1- 9
*	2-13
*	3-12
*	4-12
*	5-23
*	7-48
*	9- 9
*	14-14
*	14-17
*	15-31
*	17- 3
*	20-33
*	21-31
*	22-19
*	26-24
*	26-31
*	26-34
*	27-19
*	28-35
*	31-15
*	32-17
*	32-36
*	32-40
NUT, adjusting	14-29
NUT, castle	25-21
NUT, crown	19-16
*	32-18
NUT, flange	22- 8
NUT, self-locking	18- 5
*	18- 8

PARTS NAME INDEX

DESCRIPTION	REF. NO.
NUT, self-locking	28-32
NUT, u	9-29
*	20-10
*	30- 7
*	30-11
*	30-18
NUT, wing	28-16
O-RING	1- 2
*	1-20
*	2- 7
*	5-18
*	5-24
*	6-24
*	6-27
*	6-37
*	6-41
*	7-14
*	7-36
*	7-54
*	10-22
*	11-13
*	15-28
*	21-39
OIL SEAL	1-28
*	3- 8
*	6-11
*	11- 8
*	11-10
*	13-32
*	14-26
*	15-26
*	17- 9
*	20- 8
*	20-26
*	21- 4
*	25- 6
*	26- 5
*	31-25
PEDAL, brake	28- 2
PEDAL, shift	17-14
PILOT LIGHT ASSY	32- 9
PIN	7-24
*	7-25
PIN, clevis	14-22
*	17-16
*	27-11
*	28- 4
*	28-11
*	28-17
PIN, cotter	14-23
*	17-20
*	25-22
*	27-13

PARTS NAME INDEX

DESCRIPTION	REF. NO.
PIN, cotter	28- 6
*	28-13
*	28-19
PIN, crank 1	3- 4
PIN, dowel	1- 3
*	2-10
*	5- 3
*	6- 4
*	6-13
*	10- 2
*	11-16
*	16- 2
*	16- 7
PIN, float	7- 9
PIN, Piston	3-20
PIN, sPring	18-27
*	18-33
*	28-29
*	31-26
PIN, straight	16-16
PIPE	7- 4
*	7-65
*	7-66
PIPE, delivery 1	6-33
PIPE, exhaust 1	9- 1
PIPE, joint	8-21
PIPE, outlet	9-15
PISTON (STD)	3-18
*	3-18
PISTON (1ST O/S 0.25MM)	3-18
PISTON (2ND O/S 0.50MM)	3-18
PISTON (3RD O/S 0.75MM)	3-18
PISTON (4TH O/S 1.00MM)	3-18
PISTON RING SET (STD)	3-19
PISTON RING SET (1ST O/S)	3-19
PISTON RING SET (2ND O/S)	3-19
PISTON RING SET (3RD O/S)	3-19
PISTON RING SET (4TH O/S)	3-19
PLATE	5- 5
PLATE, bearing cover	10-15
*	10-23
PLATE, brake shoe	25- 7
*	26- 8
PLATE, cam chain sPcket	5-11
PLATE, clutch 2	14- 6
PLATE, element	8-17
PLATE, element fitting	8-16
PLATE, fitting	31- 8
PLATE, friction	14- 5
PLATE, number	21-36
PLATE, Pressure 1	14- 7
PLATE, side 1	16- 3

PARTS NAME INDEX

DESCRIPTION	REF. NO.
PLATE, stopper	16- 5
PLATE, thrust 1	14-15
PLATE, thrust 2	14- 3
PLUG	1-12
*	15-13
*	27-22
PLUG CAP ASSY	29-15
*	32-47
PLUG, drain	21-35
PLUG, screw	7-15
PLUG, sPark (NGK BP-7ES)	1-22
PLUG, straight screw	1-17
*	6-20
*	10-29
*	11-21
PLUG, viewer	1-16
PLUNGER, starter	7-52
PRIMARY DRIVEN GEAR COMP.(77T	14- 2
PROTECTOR, exhaust Pipe	9- 2
PROTECTOR, engine	18-21
PROTECTOR, muffler 1	9-18
PULLER, chain 1	26-29
RACE, ball 1	22- 1
*	22-15
RACE, ball 2	22-13
*	22-16
REAR ARM COMP.	20- 1
RETAINER, valve sPring	4- 7
RIM (1.60-21)	25-14
RIM (2.15-18)	26-16
RIM, headlight	32- 2
RIM, taillight	32-26
RING	7-57
RING, leaf	27- 4
RING, snap	21- 7
ROD, brake	28-10
ROD, chain tensioner	5-19
ROD, connecting	3- 6
ROD, Push 1	14-18
ROD, Push 2	14-19
ROTOR ASSY	12- 2
ROTOR ASSY 1	6-14
ROTOR ASSY 2	6-15
SCREW	5-22
*	6-28
*	7-27
*	7-29
*	7-67
*	16-12
*	17- 2
*	29- 3
SCREW, adjusting	14-28

PARTS NAME INDEX

DESCRIPTION	REF. NO.
SCREW, air adjusting	7-37
SCREW, bind	9- 3
*	9-19
SCREW, boot band	21-18
SCREW, countersunk	32-13
SCREW, flat head	10-16
*	10-24
*	16- 4
SCREW, Guide	7-50
SCREW, lens fitting	32-30
SCREW, Pan head	5-15
*	6- 9
*	6-10
*	7-13
*	7-20
*	7-33
*	7-40
*	7-61
*	8- 8
*	10-19
*	10-27
*	12- 5
*	12- 7
*	12-10
*	12-11
*	19-11
*	20-27
*	23-21
*	29- 7
*	29-13
*	30-10
*	30-25
*	32-21
*	32-38
*	32-46
SCREW, Panhead tapping	18-42
SCREW, throttle stop	7-51
SCREW, valve adjusting	4-11
SCREW, with washer	14- 9
SEAL	7-43
SEAL, box	19-18
SEAL, camshaft	25-13
*	26-12
SEAL, dust	21- 8
SEAL, Guard	20- 7
SEAL, steering	22- 2
SEAL, valve stem	4- 6
SEAT, check ball	6-30
SEAT, sPring	20-37
*	28-15
SEAT, sPring upper	21-20
SEAT, valve sPring	4- 5
SEMI-DOUBLE SEAT ASSY	24- 1

PARTS NAME INDEX

DESCRIPTION	REF. NO.
SEPARATOR, oil	10- 8
SHAFT, Pivot	20- 9
SHAFT, Pump	6- 3
SHAFT, rocker	4-10
SHAFT, tensioner	5-17
SHAFT, throttle lever	7-45
SHIFT CAM ASSY	16- 1
SHIFT SHAFT COMP.	17- 1
SHIM (0.3T)	20- 5
SHIM 2 (0.5T)	15- 2
SHIM, camshaft	26-15
SHIM, rod	31-22
SHOCK ABSORBER ASSY, rear	20-34
SILENCER, intake 1	8-19
SILENCER, intake 2	8-20
SOCKET	32- 6
SOCKET CORD ASSY 2	32-12
SPACER	7-38
*	13-20
*	14-10
*	20-20
*	21-21
*	25- 2
SPACER, bead	25-19
*	26-21
SPACER, bearing	26- 2
SPACER, engine mount	10-21
SPEEDOMETER ASSY	31- 1
*	31- 1
SPEEDOMETER CABLE ASSY	31-16
SPINDLE, taPer	21-11
SPOKE SET, front	25-15
SPOKE SET, rear	26-17
SPRING	7-63
*	20-36
SPRING, air adjusting	7-35
SPRING, belleville	14-16
SPRING, compression	4- 3
*	4- 4
*	5-20
*	6-32
*	13- 4
*	13-11
*	14- 8
*	16-11
*	28-14
SPRING, diaPhragm	7-23
SPRING, front fork	21-19
SPRING, Plunger	7-53
SPRING, reflector	32- 4
SPRING, tension	25- 9
*	26-10
*	28- 7

PARTS NAME INDEX

DESCRIPTION	REF. NO.
SPRING, tension	28-33
SPRING, throttle stop	7-49
SPRING, throttle valve	7-42
SPRING, torsion	1-24
*	13-19
*	14-24
*	16-21
*	17- 4
*	17-17
*	20-29
*	28- 3
*	28-24
*	28-25
SPROCKET, cam chain (17T)	5-10
SPROCKET, cam chain (34T)	5- 2
SPROCKET, drive (14T)	15-29
SPROCKET, drive (15T)	15-29
SPROCKET, drive (16T)	15-29
SPROCKET, driven (40T)	26-22
SPROCKET, driven (42T)	26-22
SPROCKET, driven (44T)	26-22
SPROCKET, driven (46T)	26-22
SPROCKET, driven (48T)	26-22
SPROCKET, driven (50T)	26-22
SPROCKET, driven (52T)	26-22
SPROCKET, driven (54T)	26-22
STAND, side	28-30
STAY, engine mount	18-11
STAY, engine mount rear	18-15
STAY, engine 2	18-19
STAY, headlight 1	32-19
STAY, muffler	9-27
STAY, Plate	21-38
STOPPER	13-26
STOPPER, cam	16-10
STOPPER, screw	17- 7
STRAINER, oil	6-16
SWITCH, handle 1	30-19
SWITCH, handle 3	32-45
TAILLIGHT ASSY	32-24
TENSIONER	20-25
THROTTLE CABLE ASSY	27- 6
TIRE (3.00-21)	25-16
TIRE (4.60-18)	26-18
TOOL KIT	18-48
TOP, mixing chamber	7-32
TUBE (2.75-21)	25-17
TUBE (4.00-18)	26-19
TUBE, inner 1	21-13
TUBE, outer 1	21- 2
TUBE, outer 2	21- 3
TUBE, throttle Guide	27- 3
UNDER BRACKET COMP.	21-25

PARTS NAME INDEX

DESCRIPTION	REF. NO.
VALVE, exhaust	4- 2
VALVE, intake	4- 1
VALVE, throttle 1	7-16
WASHER	7-26
*	7-30
*	7-44
*	7-68
*	9-24
*	9-25
*	19-12
*	23-17
*	26-23
*	27- 7
*	28-12
*	32-29
WASHER, conical sPring	14-13
*	18- 9
*	20-11
WASHER, lock	13-25
*	15-30
*	17- 5
*	17- 8
WASHER, needle valve	7- 7
WASHER, oil seal	21- 5
WASHER, outer tube	21-10
WASHER, Plain	17-19
*	29- 8
WASHER, Plate	1- 8
*	1-10
*	2- 9
*	3-10
*	3-16
*	3-17
*	5- 6
*	6- 5
*	6- 7
*	8-10
*	8-14
*	9-30
*	9-31
*	9-35
*	13- 5
*	13-14
*	13-22
*	13-23
*	13-29
*	14-27
*	14-30
*	15- 8
*	15-10
*	15-19
*	15-21

PARTS NAME INDEX

DESCRIPTION	REF. NO.
WASHER, Plate	15-23
*	16- 8
*	17-10
*	17-18
*	18-10
*	18-14
*	18-18
*	18-24
*	18-28
*	18-34
*	19- 4
*	19-10
*	19-19
*	20-15
*	20-21
*	20-30
*	20-31
*	21-27
*	23-13
*	24- 9
*	27-12
*	28- 5
*	28-18
*	28-27
*	28-28
*	29-11
*	29-14
*	30- 6
*	30-17
*	31-12
*	31-20
*	32-15
*	32-23
*	32-39
WASHER, Protector	9- 4
*	9- 5
*	9-20
*	9-21
WASHER, sPecial	31- 5
*	32-34
WASHER, sPring	3-11
*	7-12
*	7-21
*	7-34
*	7-41
*	7-47
*	7-62
*	8- 9
*	8-13
*	8-28
*	9-17
*	9-32
*	9-34

PARTS NAME INDEX

DESCRIPTION	REF. NO.
WASHER, sPring	17- 6
*	18-13
*	18-17
*	18-23
*	19- 6
*	19- 9
*	19-15
*	19-21
*	20-14
*	20-17
*	20-23
*	20-28
*	21-30
*	23-15
*	23-19
*	23-22
*	24- 8
*	26-33
*	30- 3
*	30-14
*	31-13
*	32-16
*	32-22
*	32-35
WASHER, wave	9- 6
WHEEL, ratchet	13-10
WIRE HARNESS ASSY	29-16
*	32-42
WIRE, lead	29- 4