



**PARTS  
CATALOGUE  
CATALOGO  
DE REPUESTOS**

**T105SE'05** (1D81) MEXICO



1C1D8-210S1



T105SE  
PARTS CATALOGUE  
©2003 by Yamaha Motor Co., Ltd.  
1st edition, September 2003  
All rights reserved.  
Any reprinting or unauthorized use  
without the written permission of  
Yamaha Motor Co., Ltd.  
is expressly prohibited.  
Printed in Japan.

T105SE  
CATALOGO DE REPUESTOS  
©2003 por Yamaha Motor Co., Ltd.  
1ª edición, septiembre 2003  
Todos los derechos reservados.  
Toda reproducción o uso no autorizado  
sin el consentimiento escrito de  
Yamaha Motor Co., Ltd.  
quedan expresamente prohibidos  
Impreso en Japón.

# FOREWORD

This Parts Catalogue is related to the parts for the model(s) on the cover page. When you are ordering replacement parts, please refer to this Parts Catalogue and quote both part numbers and part names correctly.

1. Modifications or additions which have been made after the issue of the Parts Catalogue will be announced in the Parts News.

It is advisable that you make the necessary corrections to the Parts Catalogue according to the Parts News.

2. Abbreviations

The following abbreviations are used in this Parts Catalogue.

“UR” Use specified parts number.

“UN” Use as many as needed.

“AP” Alternate Parts

“LM” Locally Made (Parts need to be ordered locally)

“F#” Frame No. (Applicable machine No.)

“O/S” Over Size

3. The number of components for assembly

- Parts, which are to be supplied in an assembly, are listed with a dot (.) in front of the part name as shown below.
- The numeral appearing to the right of each component part indicates the quantity of parts for each assembly unit.

PART NO.	DESCRIPTION	Q'TY	REMARKS
2F5-83310-60	FRONT FLASHER LIGHT ASSY	2	
115-83311-60	.BULB (6V-18W)	1	

4. Applicable colours of graphics are represented in the “REMARKS” as shown below.

PART NO.	DESCRIPTION	Q'TY	REMARKS
2N4-24110-00-X5	FUEL TANK COMP.	2	MXR
3J1-24240-10	.GRAPHIC, FUEL TANK	1	FOR MXR

5. Note that the illustrations for reference in finding parts numbers are not to be used for assembling. When assembling, please use the applicable service manual.

6. The asterisk (\*) before a reference number indicates modified items after the first edition.

# FOREWORD

7. Applicable Serial No.

Frame Serial No.

Engine Serial No.

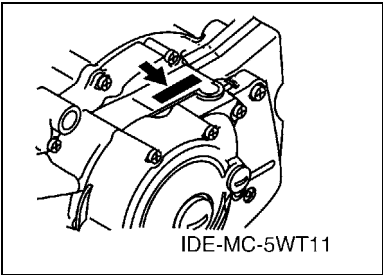
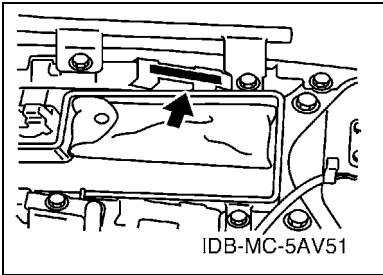

8. Applicable Colour Code (The (\*) mark shows Model colour.)

Abbreviation	Colour Name	Colour Code
CIS	CIRCUIT SILVER	00WN
DPBMC(*)	DEEP PURPLISH BLUE METALLIC C	0564
DPRC3	DARK PURPLISH RED COCKTAIL 3	0567
VRC1(*)	VIVID RED COCKTAIL 1	0121

9. Applicable Starting Serial No.

Frame Serial No.

Serial No.	Name Of Q'ty Column	Model Code

Engine Serial No.

Serial No.	Name Of Q'ty Column	Model Code

# CONTENTS

## ENGINE

CYLINDER HEAD .....	1
CRANKSHAFT & PISTON .....	2
VALVE .....	3
CAMSHAFT & CHAIN .....	4
OIL PUMP .....	5
INTAKE .....	6
CARBURETOR .....	7
EXHAUST .....	8
CRANKCASE .....	9
CRANKCASE COVER 1 .....	10
STARTER .....	11
STARTER CLUTCH .....	12
CLUTCH .....	13
TRANSMISSION .....	14
SHIFT CAM & FORK .....	15
SHIFT SHAFT .....	16

## CHASSIS

FRAME .....	17
FENDER .....	18
SIDE COVER .....	19
REAR ARM & SUSPENSION .....	21
STEERING .....	22
FRONT FORK .....	24
FUEL TANK .....	26
SEAT .....	27
SEAT 2 .....	28
FRONT WHEEL .....	29
FRONT BRAKE CALIPER .....	30
REAR WHEEL .....	31
STEERING HANDLE & CABLE .....	33
FRONT MASTER CYLINDER .....	35
STAND & FOOTREST .....	36
LEG SHIELD .....	38
GENERATOR .....	40
STARTING MOTOR .....	41
FLASHER LIGHT .....	42
METER .....	43
HEADLIGHT .....	44
TAILLIGHT .....	45
HANDLE SWITCH & LEVER .....	46

ELECTRICAL 1 .....	47
ELECTRICAL 2 .....	48

## INDEX

NUMERICAL INDEX .....	49
-----------------------	----

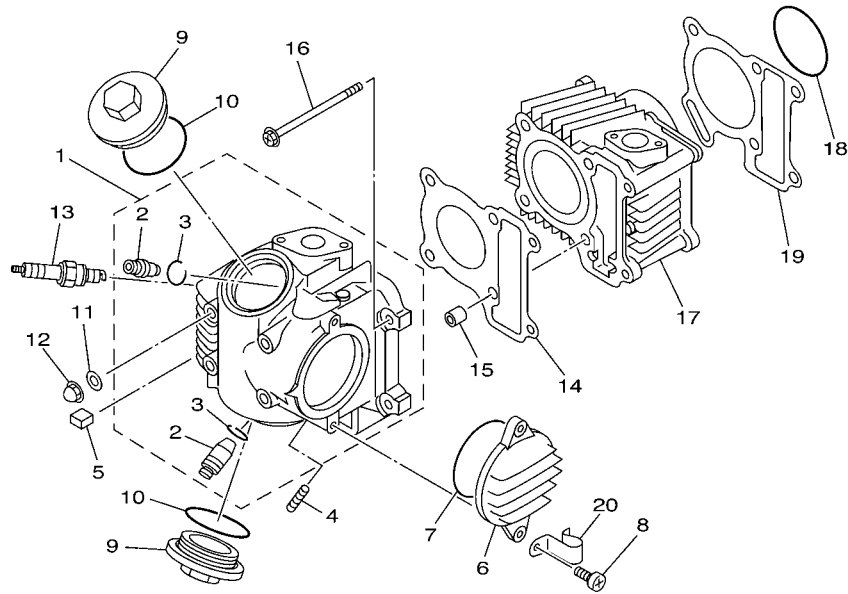

5AV4450-A010

FIG. 1 CYLINDER HEAD

CULATA DE CILINDRO

REF. NO.	PART NO. CODIGO Nº	DESCRIPTION DESCRIPCION	1D81	1D82		REMARKS OBSERVACIONES
1	5AV-E1102-01	CYLINDER HEAD ASSY CULATA DE CILINDRO COMPLETA	1	1		
2	5AV-E1134-00	.GUIDE, VALVE 2 .GUIA DE VALVULA 2	2	2		
3	93440-10153	.CIRCLIP .SEGURO	2	2		
4	5AV-E4651-00	BOLT PERNO	2	2		
5	5AV-E1161-00	ABSORBER 1 AMORTIGUADOR 1	8	8		
6	5AV-E1185-00	COVER, CYLINDER HEAD SIDE 1 CUBIERTA CULATA CIL.LAT.1	1	1		
7	93210-63556	O-RING ANILLO O	1	1		
8	98507-06016	SCREW, PAN HEAD TORNILLO DE CABEZA CON PLANA	2	2		
9	5AV-E1186-00	COVER, CYLINDER HEAD SIDE 2 CUBIERTA CULATA CIL.LAT.2	2	2		
10	93210-44704	O-RING ANILLO O	2	2		
11	90201-08609	WASHER, PLATE ARANDELA PLANA	4	4		
12	90176-08026	NUT, CROWN TUERCA CORONA	4	4		
13	94700-00846	PLUG, SPARK (NGK CR7HSA) BUJIA (NGK CR7HSA)	1	1		
14	5AV-E1181-00	GASKET, CYLINDER HEAD 1 JUNTA, DE CULATA 1	1	1		
15	99530-10114	PIN, DOWEL PASADOR, DE ESPIGA	2	2		
16	95027-06090	BOLT, FLANGE PERNO, DE BRIDA	2	2		
17	5AV-E1311-00	CYLINDER 1 CILINDRO 1	1	1		
18	93210-568G8	O-RING ANILLO O	1	1		
19	5AV-E1351-01	GASKET, CYLINDER JUNTA, DE CILINDRO	1	1		
20	90465-08230	CLAMP BRIDA	1	1		

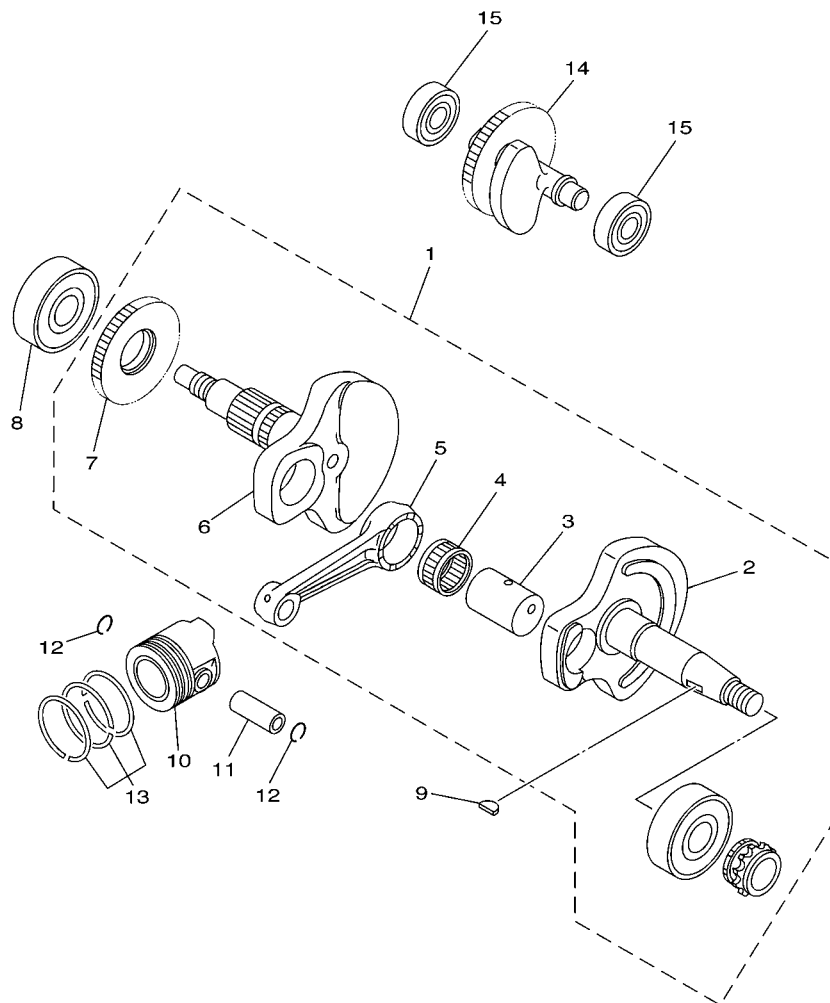

5AV4450-A021

FIG. 2 CRANKSHAFT & PISTON

CIGUENAL & PISTON

REF. NO.	PART NO. CODIGO Nº	DESCRIPTION DESCRIPCION	1D81	1D82		REMARKS OBSERVACIONES
1	5AV-E1400-20	CRANKSHAFT ASSY CIGUENAL COMPLETO	1	1		
2	5AV-E1412-00	.CRANK 1 .MANIVELA 1	1	1		
3	5AV-E1681-00	.PIN, CRANK 1 .PASADOR MANIVELA 1	1	1		
4	93310-326M9	.BEARING .COJINETE DE RODILLOS	1	1		
5	5AV-E1651-00	.ROD, CONNECTING .BIELA	1	1		
6	5AV-E1422-00	.CRANK 2 .MANIVELA 2	1	1		
7	5AV-E1536-00	.GEAR, DRIVE .ENGRANAJE TRACCION	1	1		
8	93306-20595	BEARING COJINETE	1	1		
9	90280-03017	KEY, WOODRUFF CUNA WOODRUFF	1	1		
10	5AV-E1631-01	PISTON (STD) PISTON (NORMA)	1	1		
11	5AV-E1633-00	PIN, PISTON PASADOR, PISTON	1	1		
12	93450-14088	CIRCLIP SEGURO	2	2		
13	5AV-E1610-00	PISTON RING SET (STD) JUEGO DE AROS (NORMA)	1	1		
14	5AV-E1500-00	BALANCER ASSY COMPENSADOR COMPLETA	1	1		
15	93306-20229	BEARING COJINETE	2	2		



5AV4450-A030

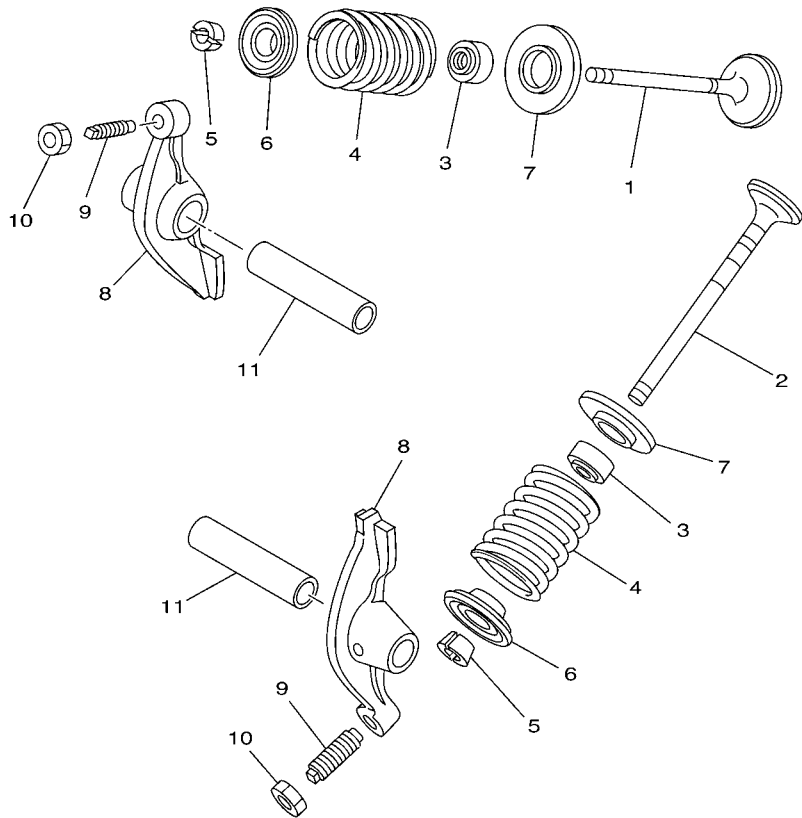
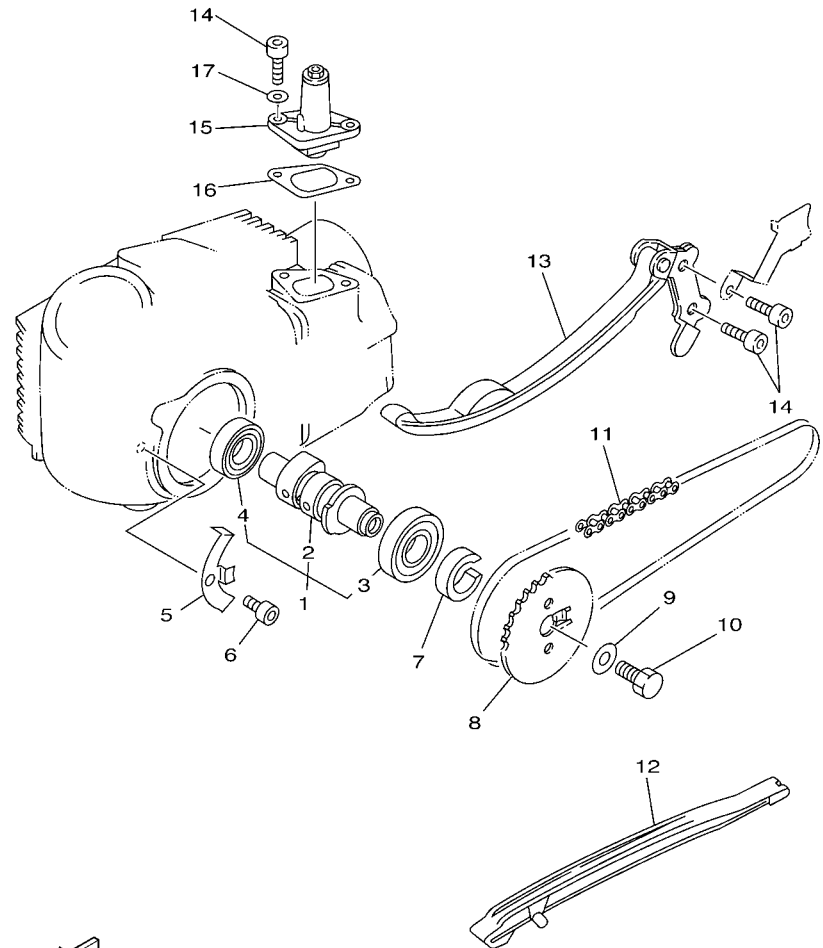

FIG. 3 VALVE

VALVULA

REF. NO.	PART NO. CODIGO Nº	DESCRIPTION DESCRIPCION	1D81	1D82		REMARKS OBSERVACIONES
1	5AV-E2111-00	VALVE, INTAKE VALVULA DE ADMISION	1	1		
2	5AV-E2121-00	VALVE, EXHAUST VALVULA DE ESCAPE	1	1		
3	4SV-12119-00	SEAL, VALVE STEM SELLO DE ACEITE VALVULA	2	2		
4	5AV-E2114-00	SPRING, VALVE OUTER RESORTE VALVULA EXTERIOR	2	2		
5	5AV-E2118-00	COTTER, VALVE SEGURO DE VALVULA	4	4		
6	5AV-E2117-00	RETAINER, VALVE SPRING RETEN RESORTE DE VALVULA	2	2		
7	5AV-E2126-00	SEAT, VALVE SPRING 2 ASIENTO RESORTE DE VALVULA2	2	2		
8	5AV-E2151-00	ARM, VALVE ROCKER BRAZO DE BALANCIN DE VALVULA	2	2		
9	5AV-E2159-00	SCREW, VALVE ADJUSTING TORNILLO DE AJUSTE DE VALVULA	2	2		
10	90170-05302	NUT TUERCA	2	2		
11	5AV-E2156-00	SHAFT, ROCKER 2 EJE DE BALANCIN	2	2		



  
5AV4450-A041

FIG. 4 CAMSHAFT & CHAIN

ARBOL DE LEVAS & CADENA

REF. NO.	PART NO. CODIGO Nº	DESCRIPTION DESCRIPCION	1D81	1D82	REMARKS OBSERVACIONES
1	5AV-E2170-00	CAMSHAFT ASSY 1 ARBOL DE LEVAS COMPLETO 1	1	1	
2	5AV-E2171-00	.CAMSHAFT 1 .ARBOL DE LEVAS 1	1	1	
3	93306-00308	.BEARING (B6003) .COJINETE (B6003)	1	1	
4	93306-00210	.BEARING .COJINETE	1	1	
5	5AV-E111F-00	PLATE PLACA	1	1	
6	91317-06012	BOLT PERNO	1	1	
7	90387-167L5	COLLAR COLLAR	1	1	
8	5AV-E2176-00	SPROCKET, CAM CHAIN CATALINA DE CADENA	1	1	
9	90201-08326	WASHER, PLATE ARANDELA PLANA	1	1	
10	90101-08590	BOLT TORNILLO	1	1	
11	5AV-E2190-00	CHAIN ASSY CADENA	1	1	
12	5AV-E2231-00	GUIDE, STOPPER 1 TOPE DE GUIA 1	1	1	
13	5AV-E2241-00	GUIDE, STOPPER 2 TOPE DE GUIA 2	1	1	
14	91317-06016	BOLT PERNO	4	4	
15	5AV-E2210-00	TENSIONER ASSY, CAM CHAIN TENSOR CADENA DE LEVA	1	1	
16	5AV-E2213-00	GASKET, TENSIONER CASE EMPAQUE DE CAJA TENSOR	1	1	
17	90430-06014	GASKET JUNTA	2	2	



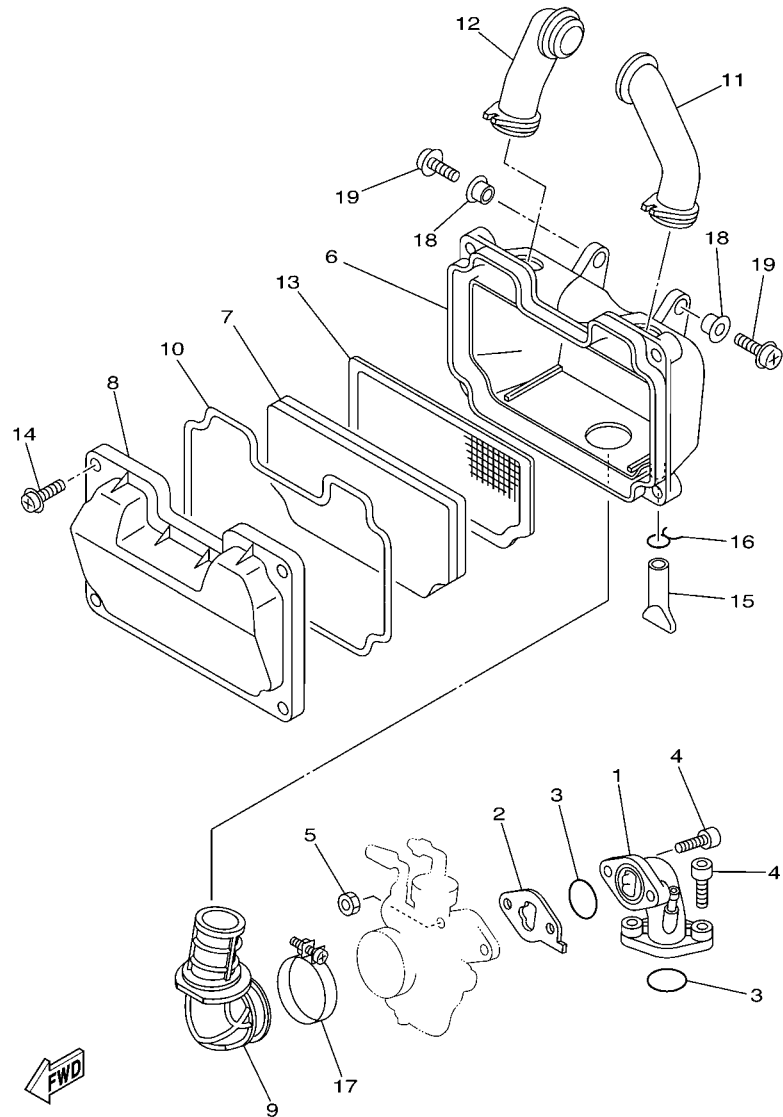

FIG. 6 INTAKE

ADMISION

REF. NO.	PART NO. CODIGO Nº	DESCRIPTION DESCRIPCION	1D81	1D82		REMARKS OBSERVACIONES
1	5AV-E3586-01	JOINT, CARBURETOR 1 TOBERA DE CARBURADOR 1	1	1		
2	5AV-E3595-01	JOINT TOBERA	1	1		
3	93210-25552	O-RING ANILLO O	2	2		
4	91317-06025	BOLT PERNO	4	4		
5	95317-06700	NUT TUERCA	2	2		
6	5AV-E4411-00	CASE, AIR CLEANER 1 CAJA FILTRO DEL AIRE 1	1	1		
7	5AV-E4451-00	ELEMENT, AIR CLEANER ELEMENTO DEL FILTRO DEL AIRE	1	1		
8	5AV-E4412-00	CAP, CLEANER CASE 1 TAPA CAJA DEL FILTRO 1	1	1		
9	5AV-E4453-00	JOINT, AIR CLEANER 1 UNION DEL FILTRO DEL AIRE 1	1	1		
10	5AV-E4452-00	SEAL SELLO	1	1		
11	5AV-E4423-00	PIPE, SUCTION 1 TUBO DE SUCCION 1	1	1		
12	5AV-E4433-00	PIPE, SUCTION 2 TUBO DE SUCCION 2	1	1		
13	5AV-E4472-01	PLATE, ELEMENT PLACA DE ELEMENTO	1	1		
14	97607-05230	SCREW, WITH WASHER TORNILLO CAB CON PLANA C/ARAN	4	4		
15	5AV-E443E-00	PIPE, DRAIN TUBO, DRENAJE	1	1		
16	90467-11106	CLIP PRESILLA	1	1		
17	90460-43179	CLAMP, HOSE BRIDA, DE UNION	1	1		
18	90387-06737	COLLAR COLLAR	2	2		
19	97607-06220	SCREW, WITH WASHER TORNILLO CAB CON PLANA C/ARAN	2	2		

FIG. 7 CARBURETOR

CARBURADOR

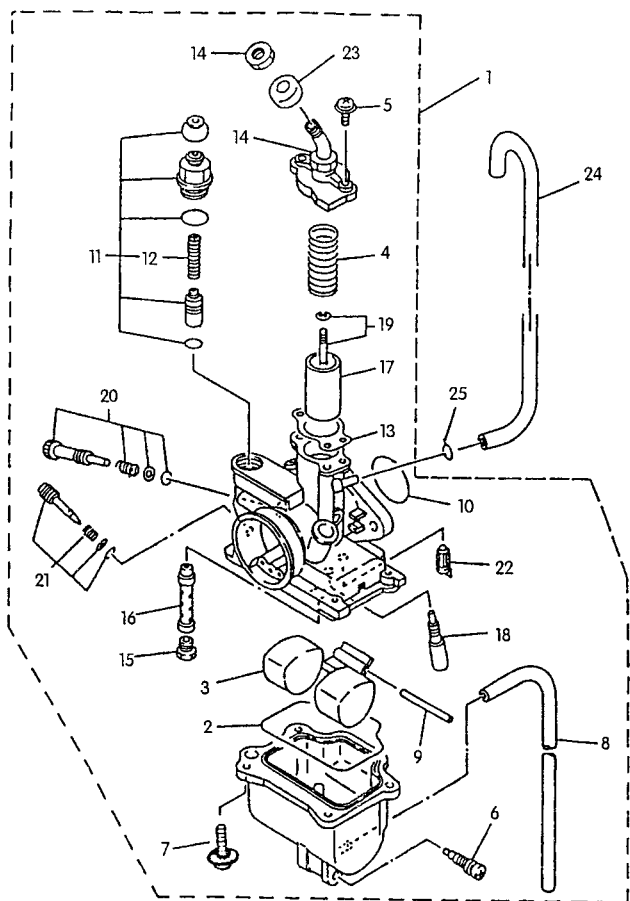

5AV4450-A070

REF. NO.	PART NO. CODIGO Nº	DESCRIPTION DESCRIPCION	1D81	1D82	REMARKS OBSERVACIONES
1	5AV-E4301-00	CARBURETOR ASSY 1 CARBURADOR COMPLETO 1	1	1	
2	5AV-E4384-00	.GASKET, FLOAT CHAMBER .EMPAQUE DE CAMARA DE BOIA	1	1	
3	5AV-E4385-00	.FLOAT .BOIA	1	1	
4	5AV-E4331-00	.SPRING, THROTTLE VALVE .RESORTE VALVULA ACELERADOR	1	1	
5	97601-04012	.SCREW, PAN HEAD WITH WASHER .TORNILLO CON RONDONA	2	2	
6	5AV-E4323-00	.SCREW, AIR ADJUSTING .TORNILLO DE AJUSTE DE AIRE	1	1	
7	97601-04014	.SCREW, PAN HEAD WITH WASHER .TORNILLO CON RONDONA	4	4	
8	4FP-E4349-00	.PIPE .TUBO	1	1	
9	6E5-E4386-01	.PIN, FLOAT .PASADOR DE BOIA	1	1	
10	214-E4513-00	.O-RING .ANILLO O	1	1	
11	5AV-E410A-00	.STARTER SET .JUEGO DE ARRANQUE	1	1	
12	5AV-E4335-00	.SPRING, PLUNGER .RESORTE DE EMBOLO	1	1	
13	4JP-E4561-00	.GASKET .EMPAQUE	1	1	
14	5AV-E4594-00	.NUT .TUERCA	2	2	
15	14T-E4343-45	.JET, MAIN (#225) .SURTIDOR, PRINCIPAL (#225)	1	1	
16	5AV-E4341-00	.NOZZLE, MAIN .BOQUILLA PRINCIPAL	1	1	
17	5AV-E4312-25	.VALVE, THROTTLE 1 .VALVULA DE OBTURADOR 1	1	1	
18	5AV-E4342-00	.JET, PILOT .ESPREA DE PILOTO	1	1	
19	5AV-E490J-00	.NEEDLE SET .CJTO. AGUJA	1	1	
20	5AV-E4103-00	.THROTTLE SCREW SET .CJTO. TORNILLO DEL RALENTI	1	1	
21	5AV-E4104-00	.AIR SCREW SET .CJTO. TORNILLO DE AIRE	1	1	
22	5AV-E4390-00	.NEEDLE VALVE ASSY .VALVULA DE AGUJA COMPLETA	1	1	
23	5AV-E4118-00	.CAP .TAPA	1	1	
24	5AV-E4197-00	PIPE TUBO RESPIRADERO	1	1	
25	90467-07029	CLIP PRESILLA	1	1	



FIG. 9 CRANKCASE

CARTER

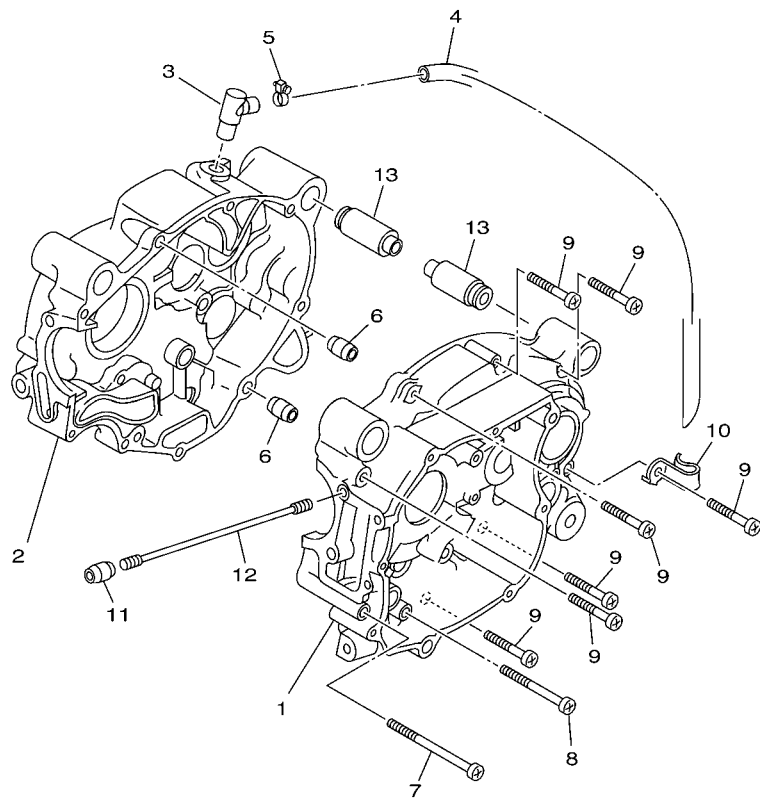

REF. NO.	PART NO. CODIGO Nº	DESCRIPTION DESCRIPCION	1D81	1D82		REMARKS OBSERVACIONES
1	5AV-E5111-00	CRANKCASE 1 CARTER MANIVELA 1	1	1		
2	5AV-E5121-00	CRANKCASE 2 CARTER MANIVELA 2	1	1		
3	5AV-E5371-00	BREATHER RESPIRADERO	1	1		
4	5AV-E1166-00	PIPE, BREATHER 1 TUBO RESPIRADERO 1	1	1		
5	90467-13064	CLIP PRESILLA	1	1		
6	99530-10114	PIN, DOWEL PASADOR, DE ESPIGA	4	4		
7	98507-06080	SCREW, PAN HEAD TORNILLO DE CABEZA PLANA	1	1		
8	98507-06060	SCREW, PAN HEAD TORNILLO DE CABEZA PLANA	1	1		
9	98507-06040	SCREW, PAN HEAD TORNILLO DE CABEZA CON PLANA	7	7		
10	90465-10833	CLAMP BRIDA	1	1		
11	99530-10114	PIN, DOWEL PASADOR, DE ESPIGA	2	2		
12	90116-08597	BOLT, STUD ESPARRAGO	4	4		
13	5AV-E5316-00	DAMPER, ENGINE MOUNT 1 AMORT. MONTANTE MOTOR 1	4	4		



5AV5450-C090

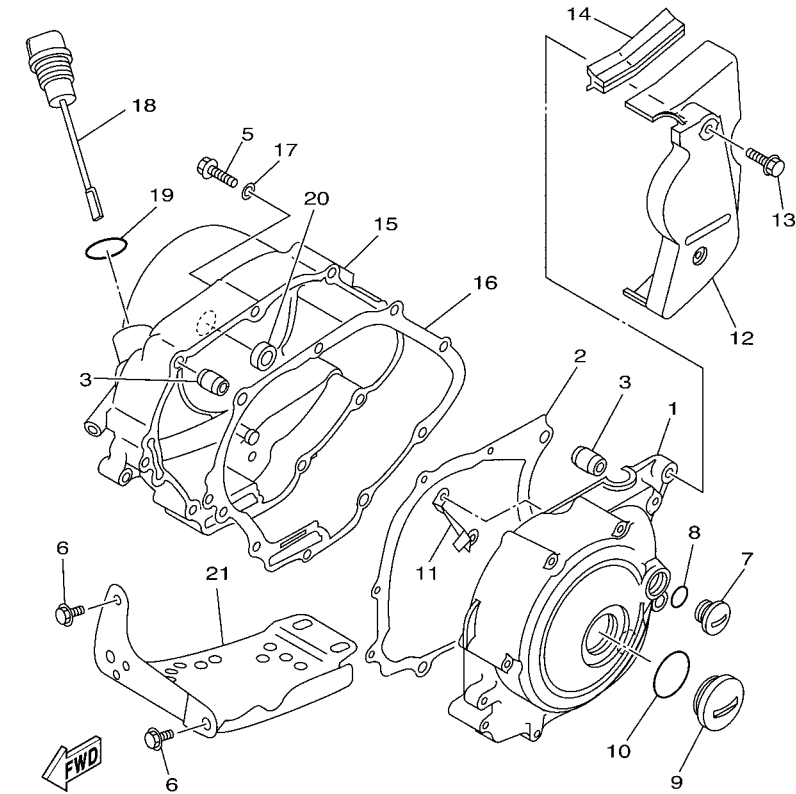
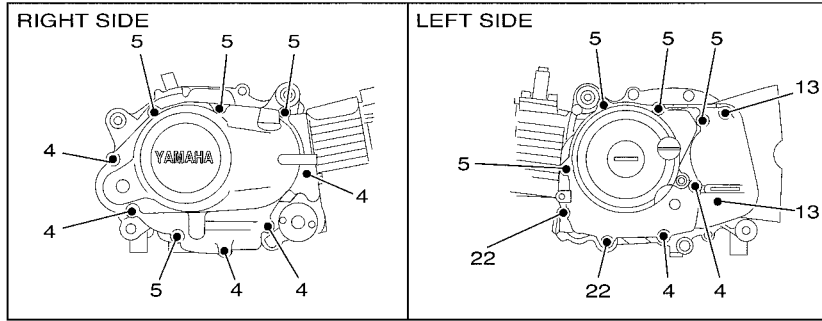

5AV5450-C100

FIG. 10 CRANKCASE COVER 1

CUBIERTA DE CARTER 1

REF. NO.	PART NO. CODIGO Nº	DESCRIPTION DESCRIPCION	ID81	ID82	REMARKS OBSERVACIONES
1	5AV-E5411-00	COVER, CRANKCASE 1 CUBIERTA DE CARTER 1	1	1	
2	5AV-E5451-10	GASKET, CRANKCASE COVER 1 EMPAQ DE CUBIERTA DE CARTER	1	1	
3	99530-10114	PIN, DOWEL PASADOR, DE ESPIGA	4	4	
4	95027-06040	BOLT, FLANGE PERNO, DE BRIDA	7	7	
5	95027-06050	BOLT, FLANGE PERNO, DE BRIDA	8	8	
6	95827-08016	BOLT, FLANGE TUERCA DE REBORDE	2	2	
7	90340-14810	PLUG, STRAIGHT SCREW TORNILLO, DE DRENAJE	1	1	
8	93210-14369	O-RING ANILLO O	1	1	
9	90340-32812	PLUG, STRAIGHT SCREW TORNILLO, DE DRENAJE	1	1	
10	93210-32172	O-RING ANILLO O	1	1	
11	5AV-E5113-00	PLATE PLACA	1	1	
12	5AV-E5418-00	COVER, CHAIN CASE CUBIERTA CAJA DE CADENA	1	1	
13	95027-06025	BOLT, FLANGE PERNO, DE BRIDA	2	2	
14	5AV-E5492-00	COVER CUBIERTA	1	1	
15	5AV-E5421-10	COVER, CRANKCASE 2 TAPA DE CARTER DERECHA	1	1	
16	5AV-E5461-00	GASKET, CRANKCASE COVER 2 JUNTA TAPA CARTER DRCHO	1	1	
17	90430-06014	GASKET JUNTA	1	1	
18	5AV-E5362-00	PLUG, OIL LEVEL TAPON DEL NIVEL DE ACEITE	1	1	
19	93210-19522	O-RING ANILLO O	1	1	
20	93101-10142	OIL SEAL SELLO ACEITE	2	2	
21	5AV-E5436-00	COVER, STARTING MOTOR CUBIERTA DE MOTOR DE ARRANQUE	1	1	
22	95027-06080	BOLT, FLANGE PERNO, DE BRIDA	2	2	



5AV4450-A110

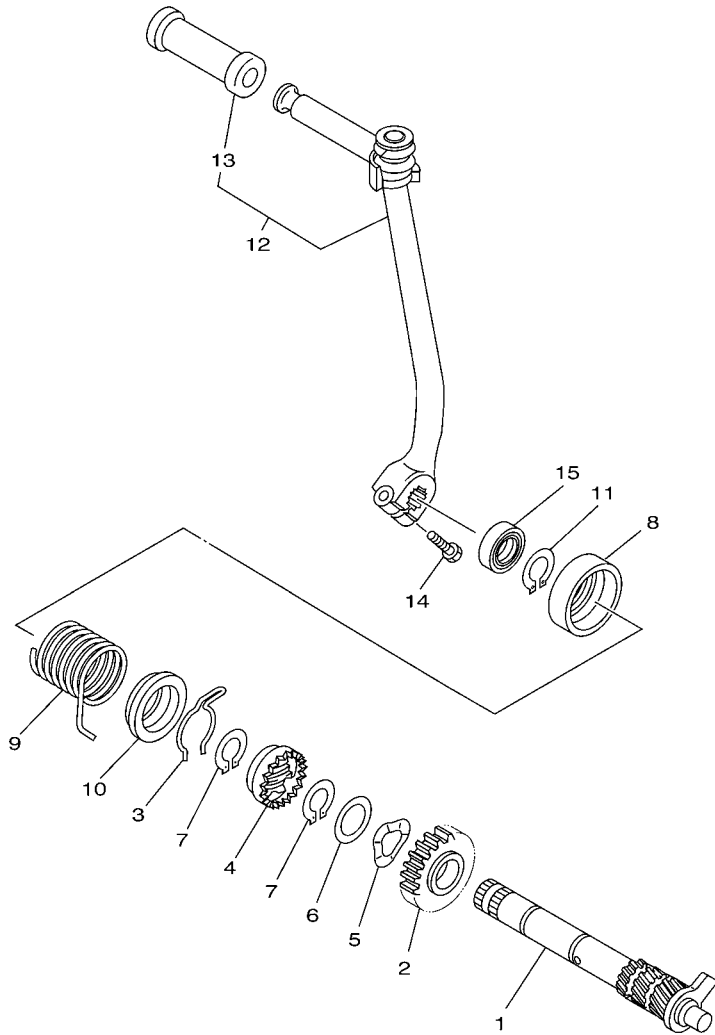

FIG. 11 STARTER

ARRANQUE

REF. NO.	PART NO. CODIGO Nº	DESCRIPTION DESCRIPCION	1D81	1D82	REMARKS OBSERVACIONES
1	5AV-E5660-00	KICK AXLE ASSY EJE DEL PEDAL DE ARRAN.COMPLET	1	1	
2	5AV-E5641-00	GEAR, KICK ENGRANAJE PEDAL ARRANQUE	1	1	
3	90468-23194	CLIP PRESILLA	1	1	
4	5AV-E5671-00	WHEEL, RATCHET RUEDA DE TRINQUETE	1	1	
5	90206-19027	WASHER, WAVE ARANDELA ONDULADA	1	1	
6	5AV-E5644-00	SHIM CUNA	1	1	
7	99009-19400	CIRCLIP PRESILLA REDONDA	2	2	
8	5AV-E5676-00	COVER, SPRING CUBIERTA DE RESORTE	1	1	
9	90508-263A8	SPRING, TORSION RESORTE DE TORSION	1	1	
10	5AV-E5664-00	GUIDE, SPRING GUIA DE RESORTE	1	1	
11	99009-15400	CIRCLIP PRESILLA REDONDA	1	1	
12	5AV-E5620-00	KICK CRANK ASSY MANIVELA DE PEDAL COMPLETA	1	1	
13	5AV-E5618-00	.COVER, KICK LEVER .GOMA PROTECTORA, PEDAL	1	1	
14	97017-06025	BOLT PERNO	1	1	
15	93102-15147	OIL SEAL SELLO ACEITE	1	1	



FIG. 13 CLUTCH

EMBRAGUE

REF. NO.	PART NO. CODIGO Nº	DESCRIPTION DESCRIPCION	1D81	1D82	REMARKS OBSERVACIONES
1	90560-16385	SPACER SEPARADOR	1	1	
2	4ST-16611-00	CLUTCH HOUSING COMP. CAJA DE EMBRAGUE COMPLETO	1	1	
3	90201-167P7	WASHER, PLATE ARANDELA PLANA	1	1	
4	5AV-E6512-00	BOSS, CLUTCH HOUSING COPA DE CAJA DE EMBRAGUE	1	1	
5	4ST-16586-00	CAGE MEDITOR	1	1	
6	93606-10227	PIN, DOWEL PASADOR DE CLAVIJA	3	3	
7	90501-037J6	SPRING, COMPRESSION RESORTE DE COMPRESION	1	1	
8	5AV-E6620-00	CLUTCH CARRIER ASSY PORTADOR DE EMBRAGUE COMPLETO	1	1	
9	5AV-E6626-00	.SPRING, CLUTCH WEIGHT 1 .RESORTE CONTRAPESO EMBRAGUE	3	3	
10	90201-122H1	WASHER, PLATE ARANDELA PLANA	1	1	
11	90179-12659	NUT TUERCA	1	1	
12	90560-17384	SPACER SEPARADOR	1	1	
13	5AV-E6150-00	PRIMARY DRIVEN GEAR COMP. CAMPANA DE EMBRAGUE	1	1	
14	5AV-E6371-00	BOSS, CLUTCH CUBO, DE EMBRAGUE	1	1	
15	2JG-16324-00	PLATE, CLUTCH 1 PLACA DE EMBRAGUE	4	4	
16	5AV-E6321-00	PLATE, FRICTION PLACA DE FRICCION	5	5	
17	5AV-E6351-00	PLATE, PRESSURE 1 PLATO DE PRESION	1	1	
18	90501-217J8	SPRING, COMPRESSION RESORTE DE COMPRESION	4	4	
19	90119-05001	BOLT, WITH WASHER TORNILLO CON ARANDELA	4	4	
20	90201-174L9	WASHER, PLATE ARANDELA PLANA	1	1	
21	90560-17328	SPACER SEPARADOR	1	1	
22	90215-14321	WASHER, LOCK ARANDELA DE CIERRE	1	1	
23	90179-14469	NUT TUERCA	1	1	
24	5AV-E6357-00	ROD, PUSH 2 VARILLA DE EMPUJE 2	1	1	
25	5AV-E6356-00	ROD, PUSH 1 VARILLA DE EMPUJE 1	1	1	
26	90201-10591	WASHER, PLATE ARANDELA PLANA	1	1	

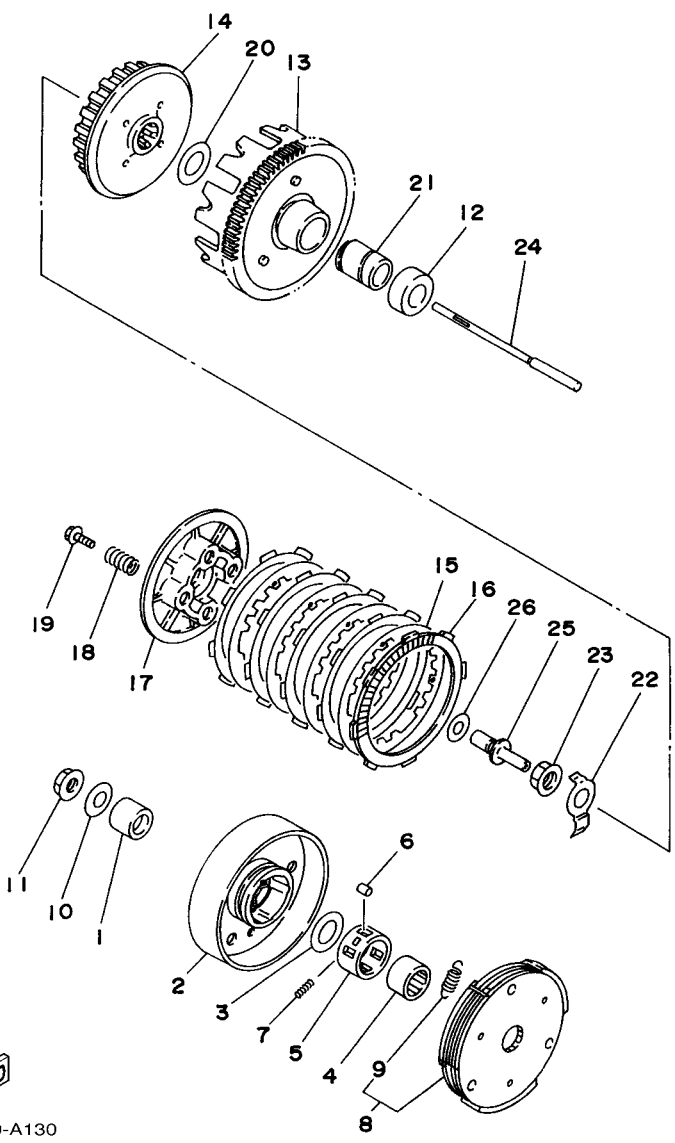

5AV4450-A130

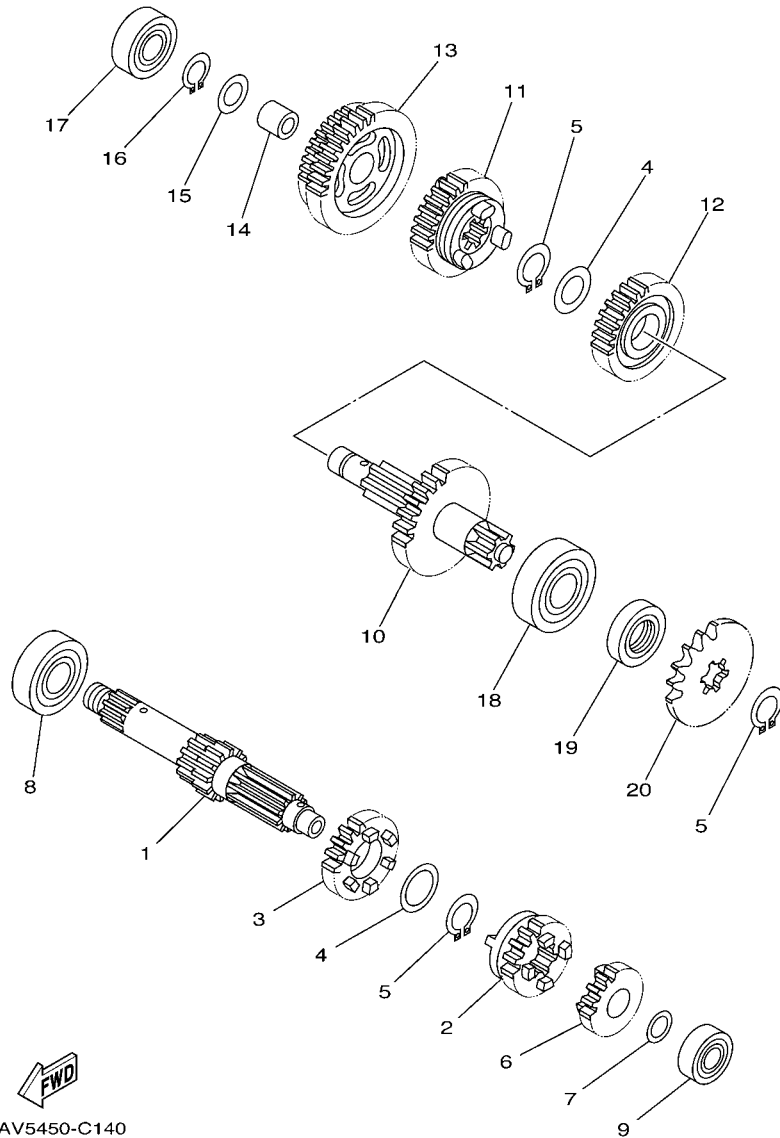

5AV5450-C140

FIG. 14 TRANSMISSION

TRANSMISSION

REF. NO.	PART NO. CODIGO Nº	DESCRIPTION DESCRIPCION	1D81	1D82		REMARKS OBSERVACIONES
1	5AV-E7411-00	AXLE, MAIN EJE PRIMARIO	1	1		
2	5AV-E7131-00	GEAR, 3RD PINION ENGRANAJE PINON DE 3RA	1	1		
3	5AV-E7141-00	GEAR, 4TH PINION ENGRANAJE PINON DE 4TA	1	1		
4	90201-20266	WASHER, PLATE (T=1.0) ARANDELA, PLACA (T=1.0)	2	2		
5	93410-20038	CIRCLIP SEGURO	3	3		
6	5AV-E7121-00	GEAR, 2ND PINION ENGRANAJE DE PINON DE 2DA	1	1		
7	90201-12166	WASHER, PLATE ARANDELA PLANA	1	1		
8	93306-203X8	BEARING COJINETE	1	1		
9	93306-001Y1	BEARING COJINETE	1	1		
10	5AV-E7402-00	DRIVE AXLE ASSY EJE DE TRACCION COMPLETO	1	1		
11	5AV-E7241-00	GEAR, 4TH WHEEL ENGRANAJE DE RUEDA 4TA	1	1		
12	5AV-E7231-00	GEAR, 3RD WHEEL ENGRANAJE RUEDA DE 3RA	1	1		
13	5AV-E7211-00	GEAR, 1ST WHEEL ENGRANAJE RUEDA DE 1 RA	1	1		
14	90387-1503D	COLLAR COLLAR	1	1		
15	90201-15700	WASHER, PLATE ARANDELA PLANA	1	1		
16	93440-15012	CIRCLIP SEGURO	1	1		
17	93306-20301	BEARING COJINETE	1	1		
18	93306-204Y6	BEARING COJINETE	1	1		
19	93102-20366	OIL SEAL SELLO ACEITE	1	1		
20	93822-15069	SPROCKET,DRIVE (15T) RUEDA DENTADA (15T)	1	1		



FIG. 16 SHIFT SHAFT

EJE DE CAMBIO & PEDAL

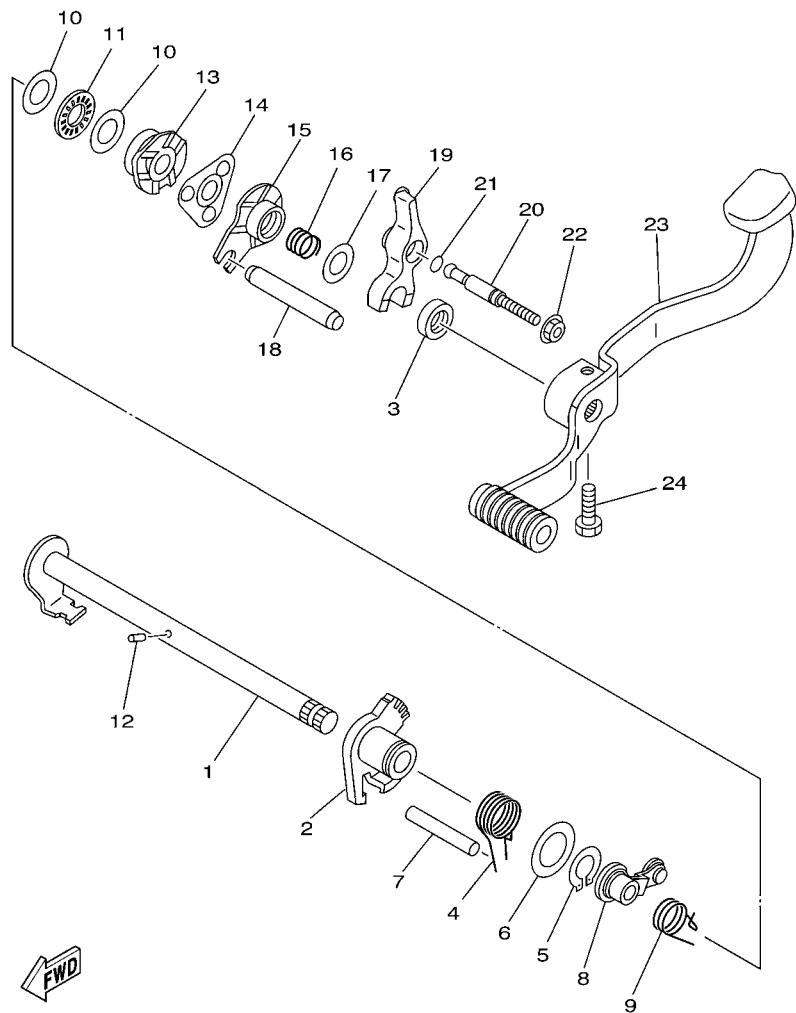

5AV4450-A160

REF. NO.	PART NO. CODIGO Nº	DESCRIPTION DESCRIPCION	1D81	1D82	REMARKS OBSERVACIONES
1	5AV-E8101-00	SHIFT SHAFT ASSY EJE SELECTOR COMPLETO	1	1	
2	5AV-E8152-00	LEVER, SHIFT 4 PALANCA DE CAMBIO 4	1	1	
3	93102-12106	OIL SEAL (SD 12-22-5 HS) SELLO ACEITE (SD 12-22-5 HS)	1	1	
4	90508-295A0	SPRING, TORSION RESORTE DE TORSION	1	1	
5	99009-20400	CIRCLIP PRESILLA REDONDA	1	1	
6	90201-20276	WASHER, PLATE (T=1.0) ARANDELA, PLACA (T=1.0)	1	1	
7	93608-50149	PIN, DOWEL PASADOR DE CLAVIJA	1	1	
8	5AV-E8140-00	STOPPER LEVER ASSY PALANCA DE TOPE COMPLETA	1	1	
9	90508-265A1	SPRING, TORSION RESORTE DE TORSION	1	1	
10	90201-127F4	WASHER, PLATE ARANDELA PLANA	2	2	
11	93340-21210	BEARING COJINETES CON RODAMIENTOS	1	1	
12	93604-10011	PIN, DOWEL PASADOR DE CLAVIJA	1	1	
13	5AV-E8179-00	GUIDE GUIA	1	1	
14	5AV-E8181-00	HOLDER, PAWL SOSTEN DE SUJETADOR	1	1	
15	5AV-E8172-00	GUIDE, SHIFT GUIA DE CAMBIO	1	1	
16	90501-125E9	SPRING, COMPRESSION RESORTE DE COMPRESION	1	1	
17	90201-126A7	WASHER, PLATE ARANDELA PLANA	1	1	
18	5AV-E8531-10	BAR, SHIFT FORK GUIDE 1 BARRA GUIA HORQ. CAMBIO 1	1	1	
19	5AV-E817A-00	ARM, SHIFT 3 BRAZO, DE CAMBIO 3	1	1	
20	5AV-E8186-00	SCREW, ADJUSTING TORNILLO DE AJUSTE	1	1	
21	93210-06422	O-RING ANILLO O	1	1	
22	95707-06500	NUT, FLANGE TUERCA DE BRIDA	1	1	
23	5AV-E8110-00	SHIFT PEDAL ASSY PEDAL DE CAMBIO COMPLETO	1	1	
24	97027-06020	BOLT PERNO	1	1	

FIG. 17 FRAME

CUADRO

REF. NO.	PART NO. CODIGO Nº	DESCRIPTION DESCRIPCION	1D81	1D82	REMARKS OBSERVACIONES
1	1D8-F1110-00	FRAME COMP. ARMAZON COMPLETO	1	1	
2	90105-08024	BOLT, FLANGE TORNILLO	3	3	
3	90201-086P8	WASHER, PLATE ARANDELA PLANA	3	3	
4	95617-08200	NUT, SELF-LOCKING TUERCA DE AUTO-CIERRE	3	3	
5	5AV-F139R-00	COVER 2 CUBIERTA 2	2	2	
6	5AV-F117F-00	COVER CUBIERTA	1	1	
7	5AV-F139X-00	DAMPER AMORTIGUADOR	3	3	
8	90149-06184	SCREW, BINDING TORNILLO DE LIGAR	2	2	
9	90480-10334	GROMMET TAPON	2	2	
10	5AV-F117N-00	COVER 3 CUBIERTA 3	1	1	
11	5AV-F8100-00	TOOL KIT JUEGO DE HERRAMIENTAS	1	1	
12	1D8-F1653-00	BOX CAJA	1		
13	1D8-F1376-00	BAND, TOOL BANDA DE HERRAMIENTA	1		
14	97007-06016	BOLT PERNO	2		
15	90201-06380	WASHER, PLATE ARANDELA PLANA	2		

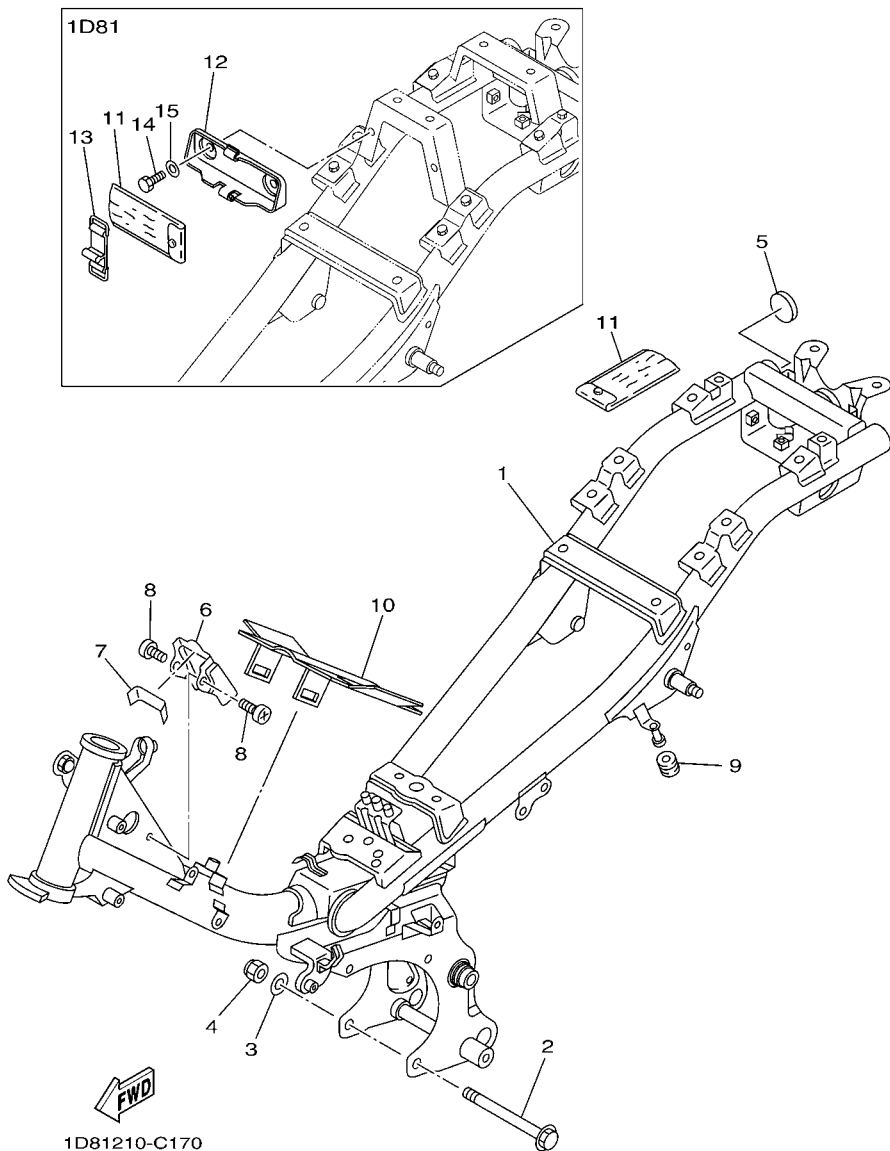

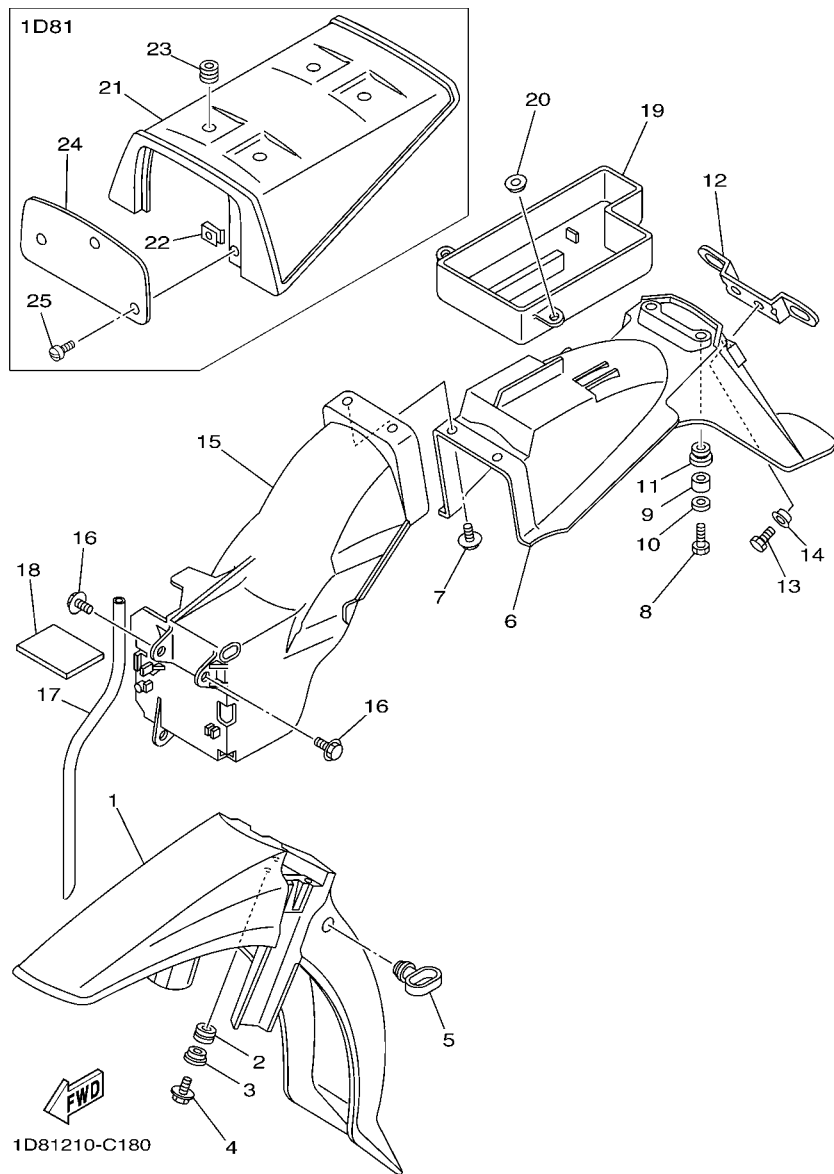

FIG. 18 FENDER

GUARDABARRO

REF. NO.	PART NO. CODIGO Nº	DESCRIPTION DESCRIPCION	1D81	1D82	REMARKS OBSERVACIONES
1	5AV-F1511-00-P2	FENDER, FRONT GUARDABARRO DELANTERO	1	1	UR VRC1 UR VRC1
	5AV-F1511-00-P3	FENDER, FRONT GUARDABARRO DELANTERO	1	1	UR DPBMC UR DPBMC
2	90480-12314	GROMMET TAPON	3	3	
3	90387-06737	COLLAR COLLAR	3	3	
4	97527-06520	BOLT, WITH WASHER PERNO CON ARANDELA RONDELLE	3	3	
5	5AV-F1518-00	HOLDER, CABLE SOPORTE DE CABLE	1	1	
6	5AV-F1611-00	FENDER, REAR GUARDABARRO TRASERO	1	1	
7	90119-06044	BOLT, WITH WASHER TORNILLO CON ARANDELA	2	2	
8	97007-06020	BOLT PERNO	2	2	
9	90387-060G7	COLLAR COLLAR	2	2	
10	90201-06557	WASHER, PLATE ARANDELA PLANA	2	2	
11	90480-13398	GROMMET TAPON	2	2	
12	5AV-F1685-00	BRACKET, LICENSE SOPORTE DE LICENCIA	1	1	
13	97007-06020	BOLT PERNO	2	2	
14	90387-06500	COLLAR COLLAR	2	2	
15	5AV-F1629-00	GUARD, MUD GUARDABARRO INFERIOR	1	1	
16	90119-06044	BOLT, WITH WASHER TORNILLO CON ARANDELA	3	3	
17	90445-08170	HOSE (L330) TUBO (L330)	1	1	
18	5AV-F1638-00	DAMPER 1 AMORTIGUADOR 1	1	1	
19	5AV-F160E-00	BOX CAJA	1		
20	90387-062M9	COLLAR COLLAR	2		
21	1D8-F4846-00	COVER 2 CUBIERTA 2	1		
22	90183-06059	NUT, SPRING TUERCA DE RESORTE	1		
23	90480-22800	GROMMET TAPON	4		
24	1D8-F4796-00	COVER CUBIERTA	1		
25	90146-06011	SCREW, OVAL FILLISTER TORNILLO CABEZA OVAL RANURADA	1		

FIG. 19 SIDE COVER

CUBIERTA LATERAL

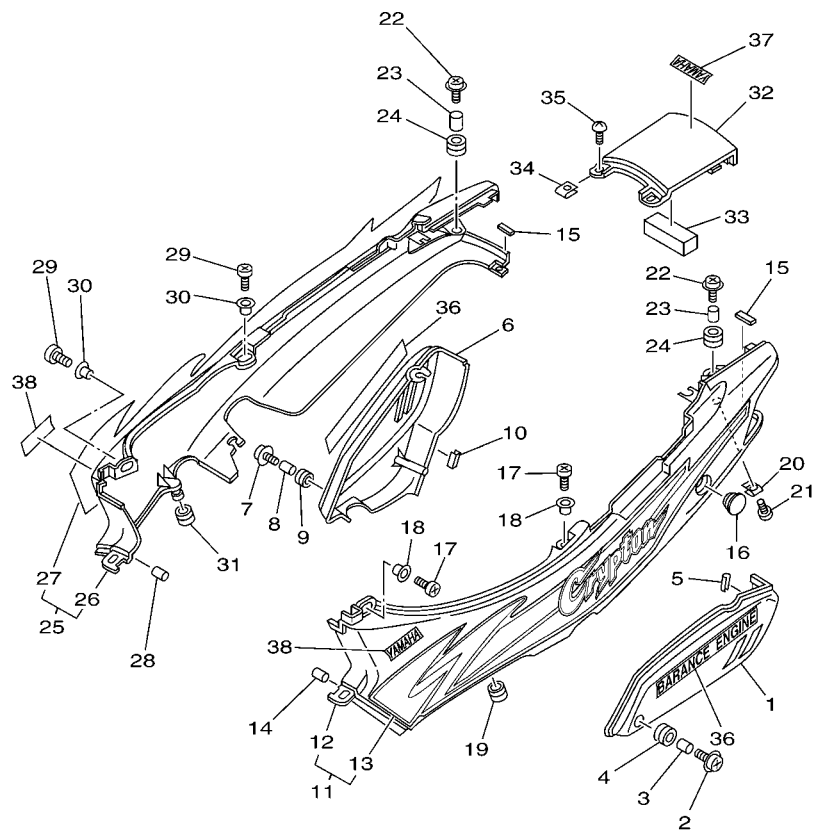

  
1D81210-C190

REF. NO.	PART NO. CODIGO Nº	DESCRIPTION DESCRIPCION	1D81	1D82	REMARKS OBSERVACIONES
1	5AV-F1711-00-P2	COVER, SIDE 1 CUBIERTA LATERAL 1	1	1	UR VRC1 UR VRC1
	5AV-F1711-00-P3	COVER, SIDE 1 CUBIERTA LATERAL 1	1	1	UR DPBMC UR DPBMC
2	90159-06067	SCREW, WITH WASHER TORNILLO CON VALONA	1	1	
3	90387-060G7	COLLAR COLLAR	1	1	
4	90480-13398	GROMMET TAPON	1	1	
5	5AV-F171M-00	MOLE, SIDE COVER 2 MUELLE, CUBIERTA LATERAL 2	2	2	
6	5AV-F1721-00-P2	COVER, SIDE 2 CUBIERTA LATERAL 2	1	1	UR VRC1 UR VRC1
	5AV-F1721-00-P3	COVER, SIDE 2 CUBIERTA LATERAL 2	1	1	UR DPBMC UR DPBMC
7	90159-06067	SCREW, WITH WASHER TORNILLO CON VALONA	1	1	
8	90387-060G7	COLLAR COLLAR	1	1	
9	90480-13398	GROMMET TAPON	1	1	
10	5AV-F171M-00	MOLE, SIDE COVER 2 MUELLE, CUBIERTA LATERAL 2	2	2	
11	5AV-F1730-00-P2	SIDE COVER ASSY 3 CUBIERTA LATERAL COMPLETA 3	1	1	UR VRC1 UR VRC1
	5AV-F1730-00-P3	SIDE COVER ASSY 3 CUBIERTA LATERAL COMPLETA 3	1	1	UR DPBMC UR DPBMC
12	5AV-F1731-00-P2	.COVER, SIDE 3 .TAPA LATERAL 3	1	1	UR VRC1 UR VRC1
	5AV-F1731-00-P3	.COVER, SIDE 3 .TAPA LATERAL 3	1	1	UR DPBMC UR DPBMC
13	5AV-F173E-60	.GRAPHIC 1 .GRAFICO 1	1	1	UR FOR VRC1 UR PARA VRC1
	5AV-F173E-70	.GRAPHIC 1 .GRAFICO 1	1	1	UR FOR DPBMC UR PARA DPBMC
14	5AV-F622F-00	DAMPER, LOCATING 1 AMORTIGUADOR, DE UBICACION 1	2	2	
15	5AV-F174X-01	DAMPER AMORTIGUADOR	2	2	
16	1D8-F172W-00	COVER CUBIERTA	1		
17	98507-06016	SCREW, PAN HEAD TORNILLO DE CABEZA CON PLANA	2	2	
18	90387-06500	COLLAR COLLAR	2	2	
19	90480-10334	GROMMET TAPON	1	1	
20	90183-05807	NUT, SPRING TUERCA DE RESORTE	1	1	
21	90167-05025	SCREW, TAPPING TORNILLO DE ROSCA HEMBRA	1	1	
22	90159-06085	SCREW, WITH WASHER TORNILLO CON VALONA	2	2	

FIG. 19 SIDE COVER

CUBIERTA LATERAL

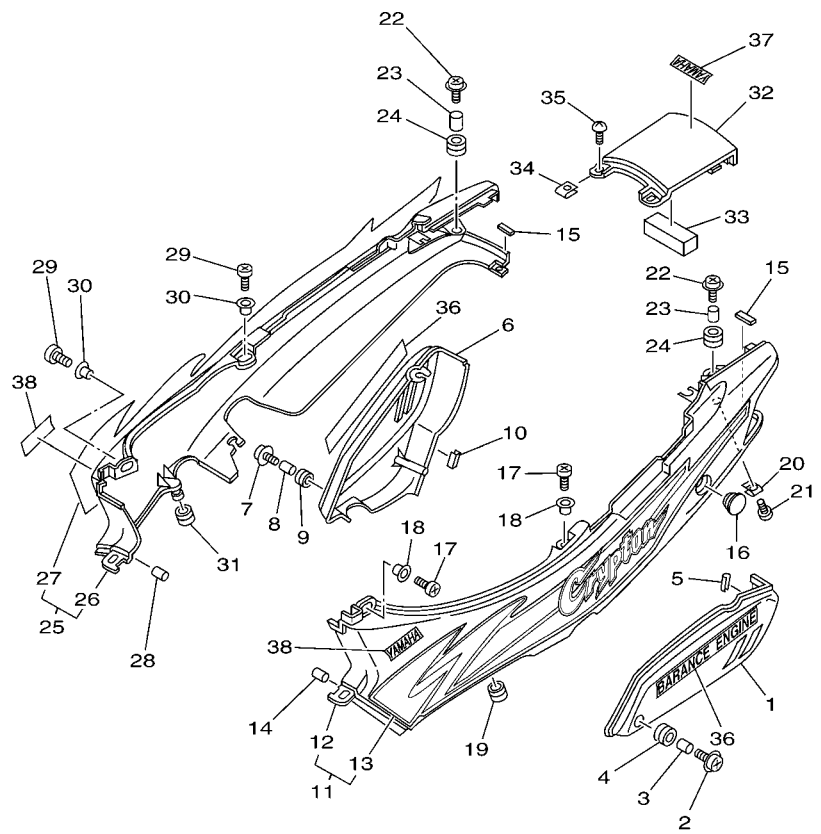

REF. NO.	PART NO. CODIGO Nº	DESCRIPTION DESCRIPCION	1D81	1D82	REMARKS OBSERVACIONES
23	90387-060G7	COLLAR COLLAR	2	2	
24	90480-13398	GROMMET TAPON	2	2	
25	5AV-F1740-00-P2	SIDE COVER ASSY 4 CUBIERTA LAT. COMPLETA 4	1	1	UR VRC1 UR VRC1
	5AV-F1740-00-P3	SIDE COVER ASSY 4 CUBIERTA LAT. COMPLETA 4	1	1	UR DPBMC UR DPBMC
26	5AV-F1741-00-P2	.COVER, SIDE 4 .CUBIERTA LATERAL 4	1	1	UR VRC1 UR VRC1
	5AV-F1741-00-P3	.COVER, SIDE 4 .CUBIERTA LATERAL 4	1	1	UR DPBMC UR DPBMC
27	5AV-F173F-60	.GRAPHIC 2 .GRAFICO	1	1	UR FOR VRC1 UR PARA VRC1
	5AV-F173F-70	.GRAPHIC 2 .GRAFICO	1	1	UR FOR DPBMC UR PARA DPBMC
28	5AV-F622F-00	DAMPER, LOCATING 1 AMORTIGUADOR, DE UBICACION 1	2	2	
29	98507-06016	SCREW, PAN HEAD TORNILLO DE CABEZA CON PLANA	2	2	
30	90387-06500	COLLAR COLLAR	2	2	
31	90480-10334	GROMMET TAPON	1	1	
32	5AV-F171E-00-P2	COVER, SIDE 5 CUBIERTA LATERAL 5	1	1	UR VRC1 UR VRC1
	5AV-F171E-00-P3	COVER, SIDE 5 CUBIERTA LATERAL 5	1	1	UR DPBMC UR DPBMC
33	5AV-F174Y-00	DAMPER AMORTIGUADOR	1	1	
34	90183-05807	NUT, SPRING TUERCA DE RESORTE	2	2	
35	90167-05025	SCREW, TAPPING TORNILLO DE ROSCA HEMBRA	2	2	
36	5AV-F174G-00	GRAPHIC 3 GRAFICO 3	2	2	
37	99236-00080	EMBLEM, YAMAHA EMBLEMA, YAMAHA	1	1	
38	99236-00100	EMBLEM, YAMAHA EMBLEMA, YAMAHA	2	2	



1D81210-C190

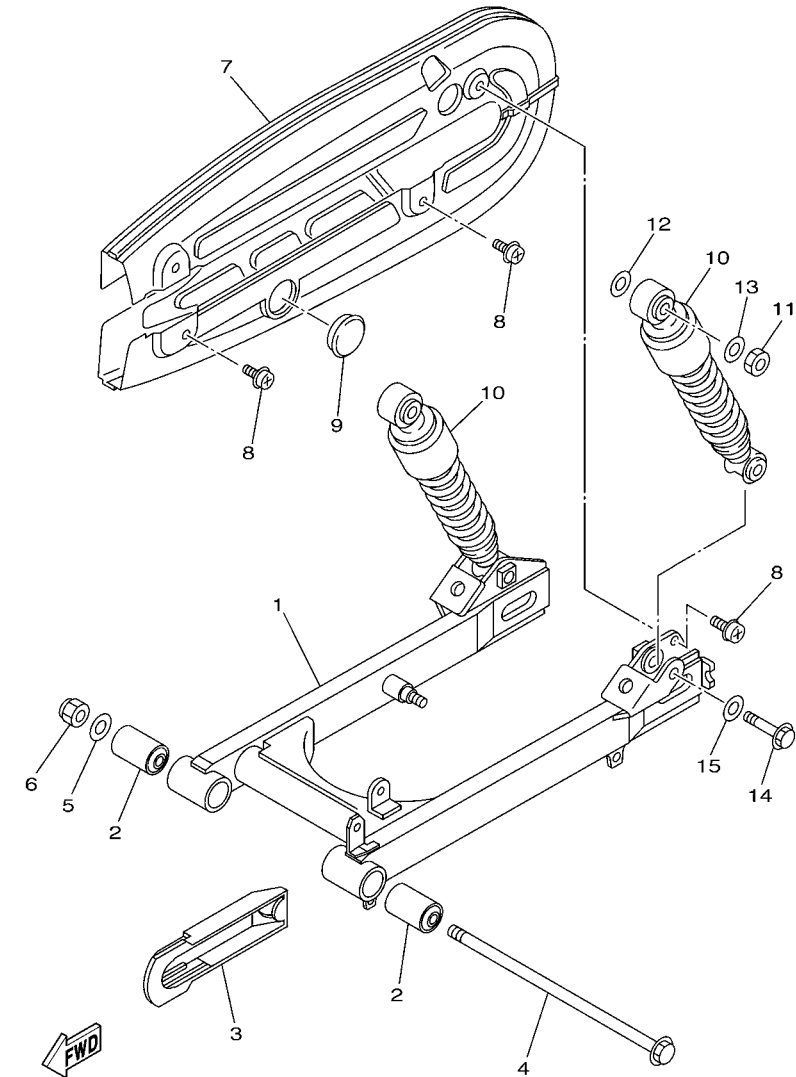

5AV5450-C200

FIG. 20 REAR ARM & SUSPENSION

BRAZO TRASERO & SUSPENSION

REF. NO.	PART NO. CODIGO Nº	DESCRIPTION DESCRIPCION	1D81	1D82		REMARKS OBSERVACIONES
1	5AV-F2110-00	REAR ARM COMP. BRAZO TRASERO COMPLETO	1	1		
2	5AV-F2123-00	BUSH 1 BUJE 1	2	2		
3	5AV-F2151-00	SEAL, GUARD SELLO DE GUARDA	1	1		
4	5AV-F2141-00	SHAFT, PIVOT EJE DEL BARCULANTE	1	1		
5	92903-12600	WASHER RONDANA SENCILLA	1	1		
6	90185-12046	NUT, SELF-LOCKING TUERCA AUTOBLOCANTE	1	1		
7	5AV-F2310-00	CHAIN CASE ASSY CAJA DE CADENA COMPLETA	1	1		
8	97607-06210	SCREW, WITH WASHER TORNILLO CAB CON PLANA C/ARAN	4	4		
9	47V-F2315-00	CAP TAPA	1	1		
10	5AV-F2210-00	SHOCK ABSORBER ASSY, REAR AMORTIGUADOR TRASERO COMPLETO	2	2		
11	95307-10600	NUT TUERCA	2	2		
12	90201-12190	WASHER, PLATE ARANDELA PLANA	2	2		
13	90201-106F2	WASHER, PLATE ARANDELA PLANA	2	2		
14	90105-10778	BOLT, FLANGE TORNILLO	2	2		
15	92907-10600	WASHER, PLATE ARANDELA	2	2		

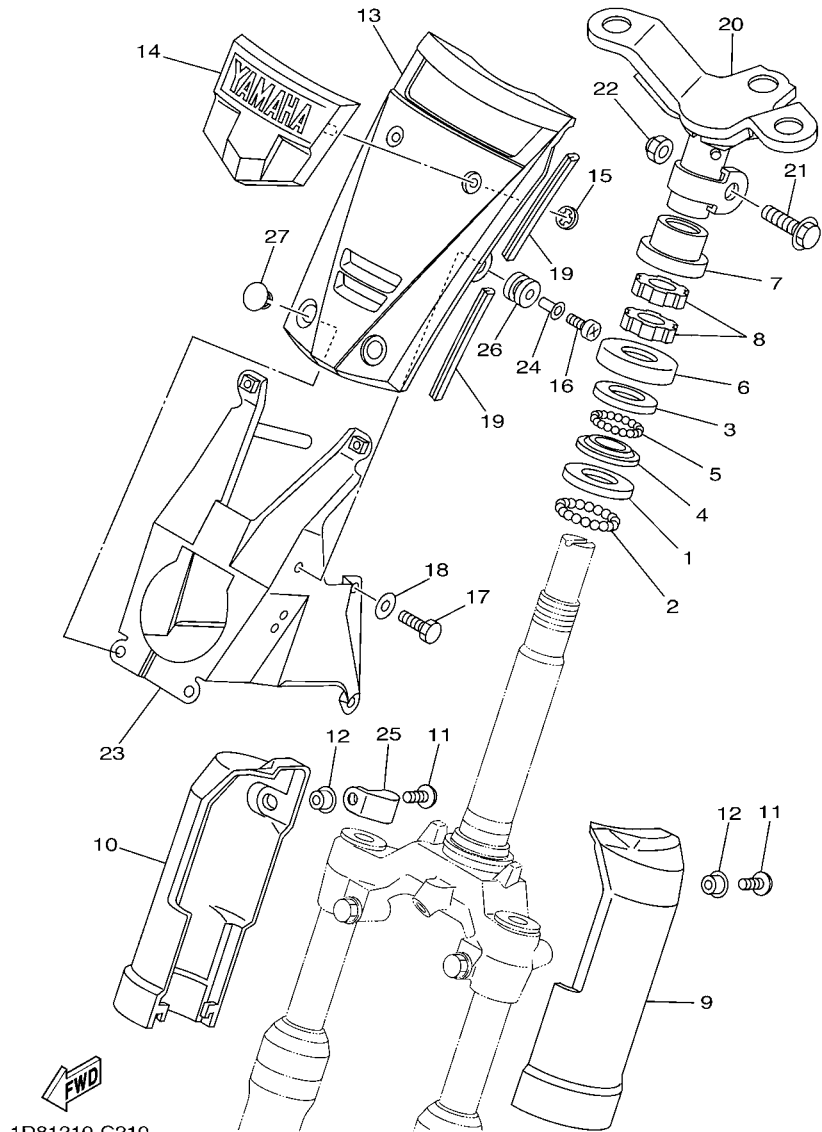

1D81210-C210

FIG. 21 STEERING

DIRECCION

REF. NO.	PART NO. CODIGO Nº	DESCRIPTION DESCRIPCION	1D81	1D82	REMARKS OBSERVACIONES
1	1KL-F3412-00	RACE, BALL 2 PISTA DE BOLAS 2	1	1	
2	93501-04011	BALL BOLA	19	19	
3	47V-F3412-00	RACE, BALL 2 PISTA DE BOLAS 2	1	1	
4	47V-F3411-00	RACE, BALL 1 PISTA DE BOLAS 1	1	1	
5	93503-16003	BALL ESFERA	22	22	
6	5AV-F3416-00	COVER, BALL RACE 2 CUBIERTA DE BASE DE BOLA 2	1	1	
7	5AV-F3415-00	COVER, BALL RACE 1 CUBIERTA DE PISTA DE BOLAS 1	1	1	
8	90179-25033	NUT TUERCA	2	2	
9	5AV-F3122-00-P2	COVER, OUTER 1 CUBIERTA EXTERIOR 1	1	1	UR VRC1 UR VRC1
	5AV-F3122-00-P3	COVER, OUTER 1 CUBIERTA EXTERIOR 1	1	1	UR DPBMC UR DPBMC
10	5AV-F3132-00-P2	COVER, OUTER 2 CUBIERTA EXTERIOR 2	1	1	UR VRC1 UR VRC1
	5AV-F3132-00-P3	COVER, OUTER 2 CUBIERTA EXTERIOR 2	1	1	UR DPBMC UR DPBMC
11	98507-06016	SCREW, PAN HEAD TORNILLO DE CABEZA CON PLANA	2	2	
12	90387-06681	COLLAR COLLAR	2	2	
13	5AV-F3391-00-P2	PANEL, FRONT PANEL DELANTERO	1	1	UR VRC1 UR VRC1
	5AV-F3391-00-P3	PANEL, FRONT PANEL DELANTERO	1	1	UR DPBMC UR DPBMC
14	5AV-F3108-10	EMBLEM EMBLEMA	1	1	
15	90183-04005	NUT, SPRING TUERCA DE RESORTE	2	2	
16	98907-05010	SCREW, BIND TORNILLO DE LIGAR	2	2	
17	97107-06012	BOLT PERNO	4	4	
18	92907-06600	WASHER, PLATE ARANDELA	4	4	
19	5AV-F3398-00	MOLD, FRONT MOLDURA DELANTERA	4	4	
20	5AV-F3461-00	BRACKET, HANDLE SOPORTE DE MANUBRIO	1	1	
21	90105-10036	BOLT, FLANGE TORNILLO	1	1	
22	90185-10154	NUT, SELF-LOCKING TUERCA AUTOBLOCANTE	1	1	
23	5AV-F331A-00	STAY APOYO	1	1	
24	90387-053Y7	COLLAR COLLAR	2	2	



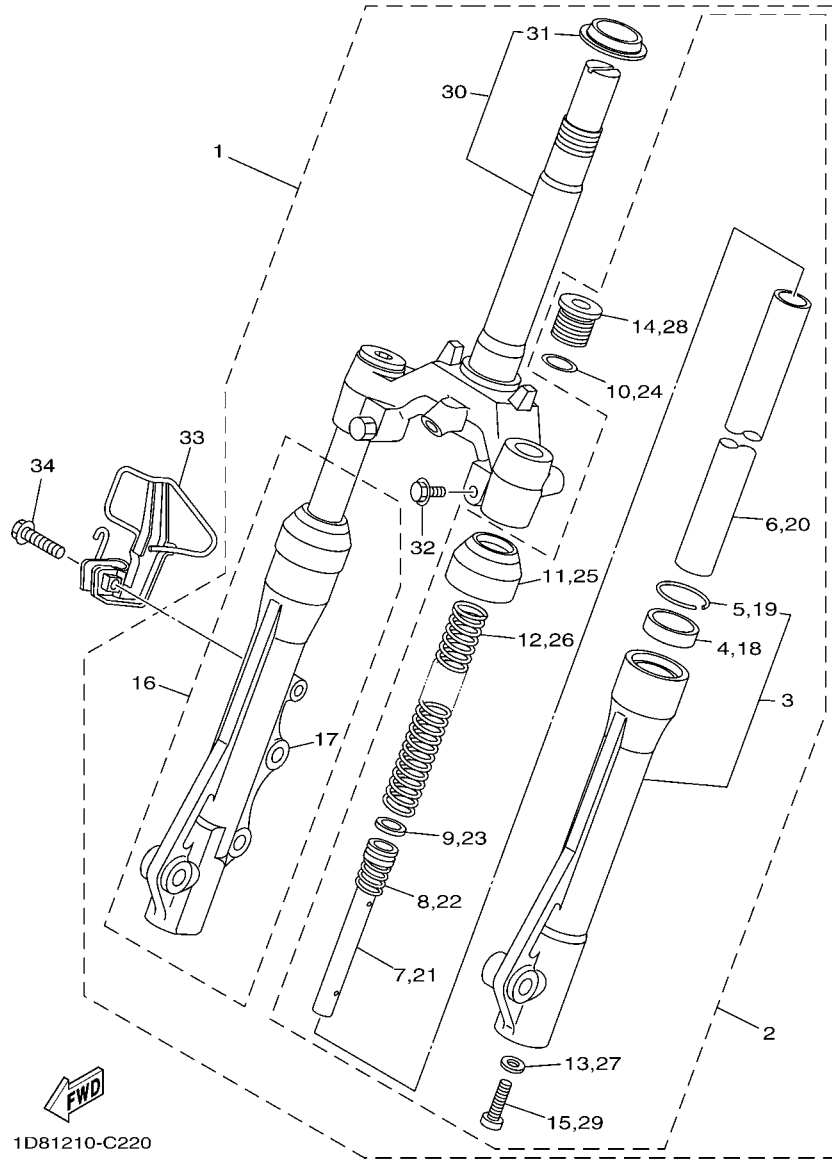

1D81210-C220

FIG. 22 FRONT FORK

HORQUILLA DELANTERA

REF. NO.	PART NO. CODIGO Nº	DESCRIPTION DESCRIPCION	1D81	1D82		REMARKS OBSERVACIONES
1	5AV-F3100-10	FRONT FORK ASSY HORQUILLA DELANTERA COMPLETA	1	1		
2	5AV-F3102-10	FRONT FORK ASSY (L.H) HORQUILLA DELANTERA COMPL.(MI)	1	1		
3	5AV-F3126-10	.TUBE, OUTER (LEFT) .TUBO EXTERIOR (IZQUIERDO)	1	1		
4	5AV-F3145-00	..OIL SEAL ..RETEN DE ACEITE	1	1		
5	5AV-F3156-00	..CLIP, OIL SEAL ..PRESILLA DEL RETEN DE ACEITE	1	1		
6	5AV-F3110-00	..INNER TUBE COMP.1 ..TUBO INTERIOR COMPLETO 1	1	1		
7	5AV-F3170-00	.CYLINDER COMP., FRONT FORK .CILINDRO COMPL DE HORQ DELAN	1	1		
8	5AV-F3152-00	.SPRING, SUB .RESORTE DE SUBENSAMBLE	1	1		
9	5AV-F3157-00	.RING, PISTON .ANILLO DEL PISTON	1	1		
10	5AV-F3147-00	.O-RING .ARO	1	1		
11	5AV-F3144-00	.SEAL, DUST .GUARDAPOLVO	1	1		
12	5AV-F3141-00	.SPRING, FRONT FORK .RESORTE HORQUILLA DELANT.	1	1		
13	5AV-F3158-L0	.GASKET .EMPAQUE	1	1		
14	5AV-F3111-00	.BOLT, CAP .TAPON	1	1		
15	5AV-F3181-50	.BOLT, HEXAGON SOCKET HEAD .TORNILLO CABEZAHEXAGONAL	1	1		
16	5AV-F3103-10	FRONT FORK ASSY (R.H) HORQUILLA DELANTERA COMPL.(MD)	1	1		
17	5AV-F3136-10	.TUBE, OUTER (RIGHT) .TUBO EXTERIOR (DER.)	1	1		
18	5AV-F3145-00	..OIL SEAL ..RETEN DE ACEITE	1	1		
19	5AV-F3156-00	..CLIP, OIL SEAL ..PRESILLA DEL RETEN DE ACEITE	1	1		
20	5AV-F3110-00	..INNER TUBE COMP.1 ..TUBO INTERIOR COMPLETO 1	1	1		
21	5AV-F3170-00	.CYLINDER COMP., FRONT FORK .CILINDRO COMPL DE HORQ DELAN	1	1		
22	5AV-F3152-00	.SPRING, SUB .RESORTE DE SUBENSAMBLE	1	1		
23	5AV-F3157-00	.RING, PISTON .ANILLO DEL PISTON	1	1		
24	5AV-F3147-00	.O-RING .ARO	1	1		
25	5AV-F3144-00	.SEAL, DUST .GUARDAPOLVO	1	1		
26	5AV-F3141-00	.SPRING, FRONT FORK .RESORTE HORQUILLA DELANT.	1	1		
27	5AV-F3158-L0	.GASKET .EMPAQUE	1	1		



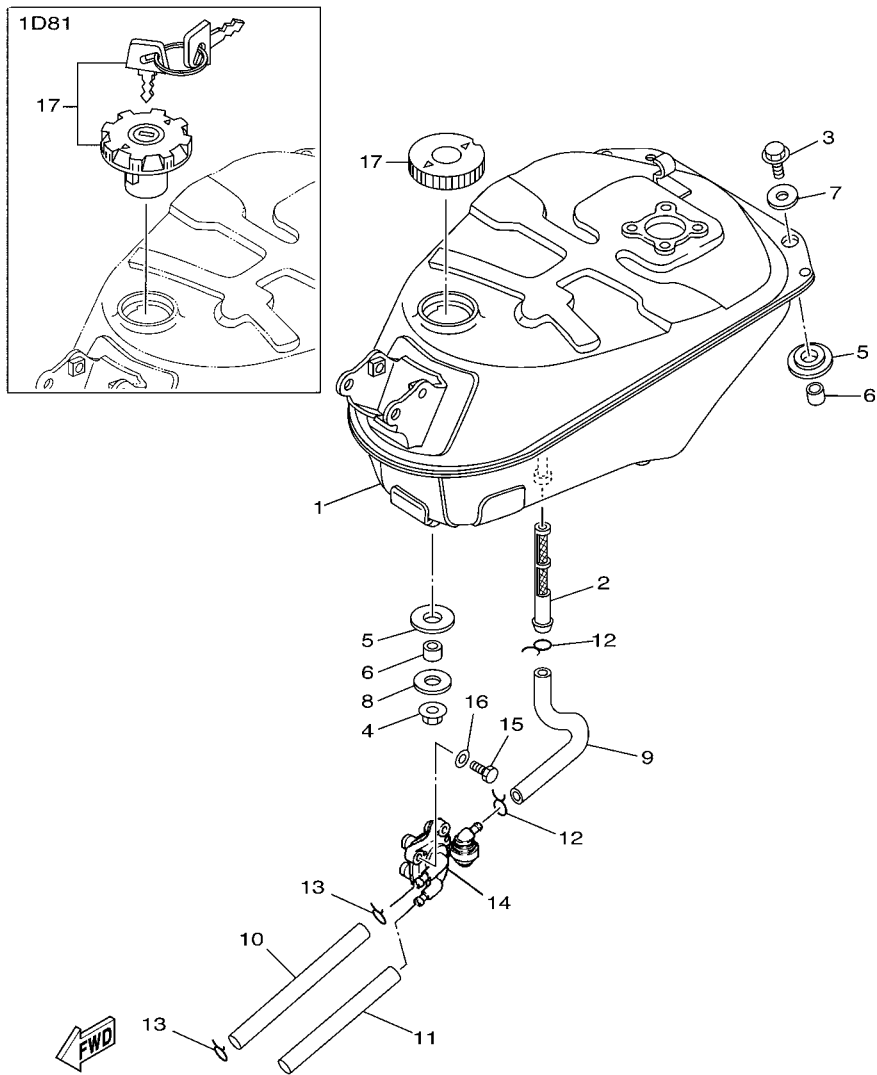

1D81210-C230

FIG. 23 FUEL TANK

DEPOSITO DE COMBUSTIBLE

REF. NO.	PART NO. CODIGO Nº	DESCRIPTION DESCRIPCION	1D81	1D82	REMARKS OBSERVACIONES
1	5AV-F4110-00	FUEL TANK COMP. DEPOSITO DE COMBUSTIBLE COMP.	1	1	
2	5AV-F4514-00	NET, FILTER 1 RED. DE FILTRO 1	1	1	
3	97007-06020	BOLT PERNO	2	2	
4	95707-08500	NUT, FLANGE TUERCA DE BRIDA	1	1	
5	90480-18476	GROMMET TAPON	3	3	
6	90387-084N8	COLLAR COLLAR	3	3	
7	90201-064K6	WASHER, PLATE ARANDELA PLANA	2	2	
8	90201-08766	WASHER, PLATE ARANDELA PLANA	1	1	
9	5AV-F4311-00	PIPE, FUEL 1 TUBO DE COMBUSTIBLE 1	1	1	
10	5AV-F4312-10	PIPE 2 TUBO 2	1	1	
11	5AV-F4313-00	PIPE 3 TUBO 3	1	1	
12	90467-10008	CLIP PRESILLA	2	2	
13	90467-10008	CLIP PRESILLA	2	2	
14	5AV-F4500-00	FUEL COCK ASSY 1 GRIFO DE COMBUSTIBLE 1	1	1	
15	97017-06012	BOLT PERNO	2	2	
16	92907-06600	WASHER, PLATE ARANDELA	2	2	
17	1D8-F461A-00	CAP ASSY(WITH KEY) CONJUNTO DEL TACOMETRO	1		
	5AV-F4602-V0	CAP ASSY TAPON COMPLETO		1	

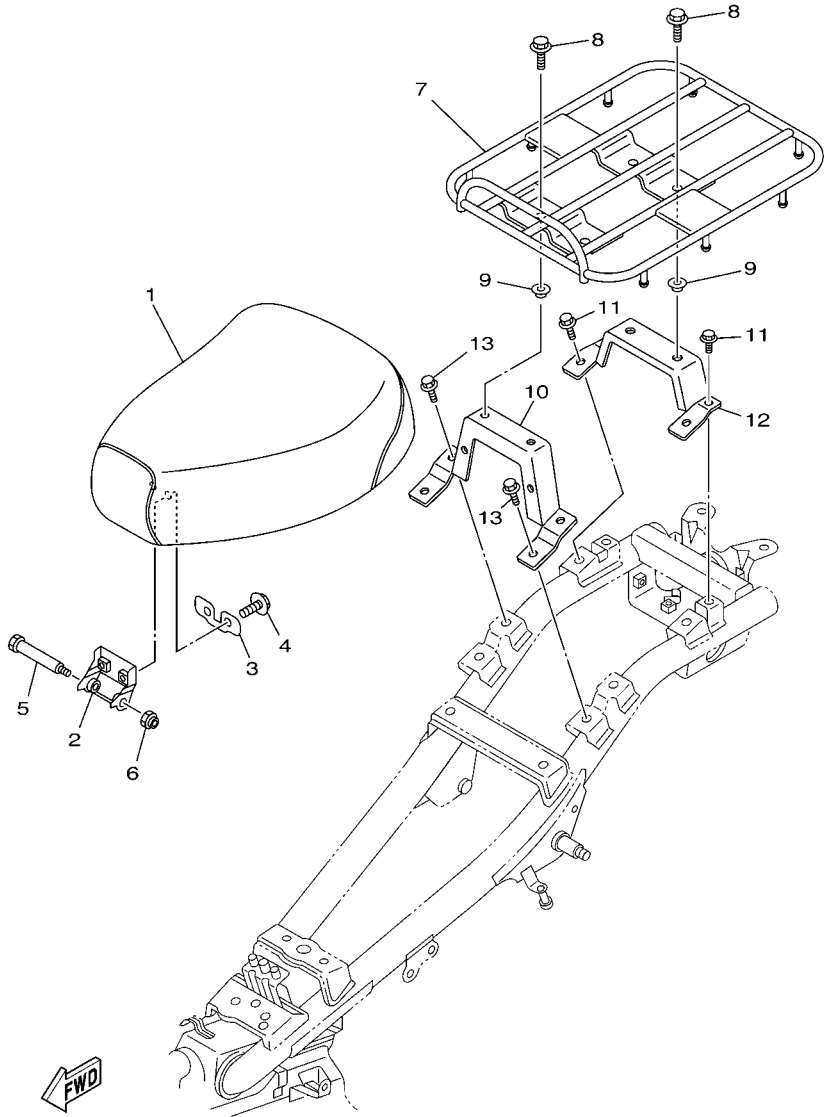

1D81210-C240

FIG. 24 SEAT

ASIENTO

REF. NO.	PART NO. CODIGO Nº	DESCRIPTION DESCRIPCION	1D81	1D82		REMARKS OBSERVACIONES
1	1D8-F4710-00	SINGLE SEAT ASSY ASIENTO SIMPLE COMPLETO	1			
2	5AV-F4726-00	HINGE, SEAT HINGE SEAT	1			
3	5AV-F4744-00	PLATE, SEAT FITTING PLACA ACCESORIA DE ASIENTO	1			
4	90119-06044	BOLT, WITH WASHER TORNILLO CON ARANDELA	2			
5	90109-065E0	BOLT PERNO	1			
6	95607-06100	NUT, U TUERCA AUTOBLOCANTE	1			
7	1D8-F4810-00	CARRIER ASSY PORTADOR COMPLETO	1			
8	95827-08025	BOLT, FLANGE TUERCA DE REBORDE	4			
9	1D8-F471N-00	COLLAR 1 COLLAR 1	4			
10	1D8-F4832-00	BRACKET, CARRIER 1 SOPORTE DE PORTADOR 1	1			
11	95804-06010	BOLT, FLANGE TUERCA DE REBORDE	4			
12	1D8-F4833-00	BRACKET, CARRIER 2 SOPORTE DE PORTADOR 2	1			
13	95804-06010	BOLT, FLANGE TUERCA DE REBORDE	4			

FIG. 25 SEAT 2

ASIENTO 2

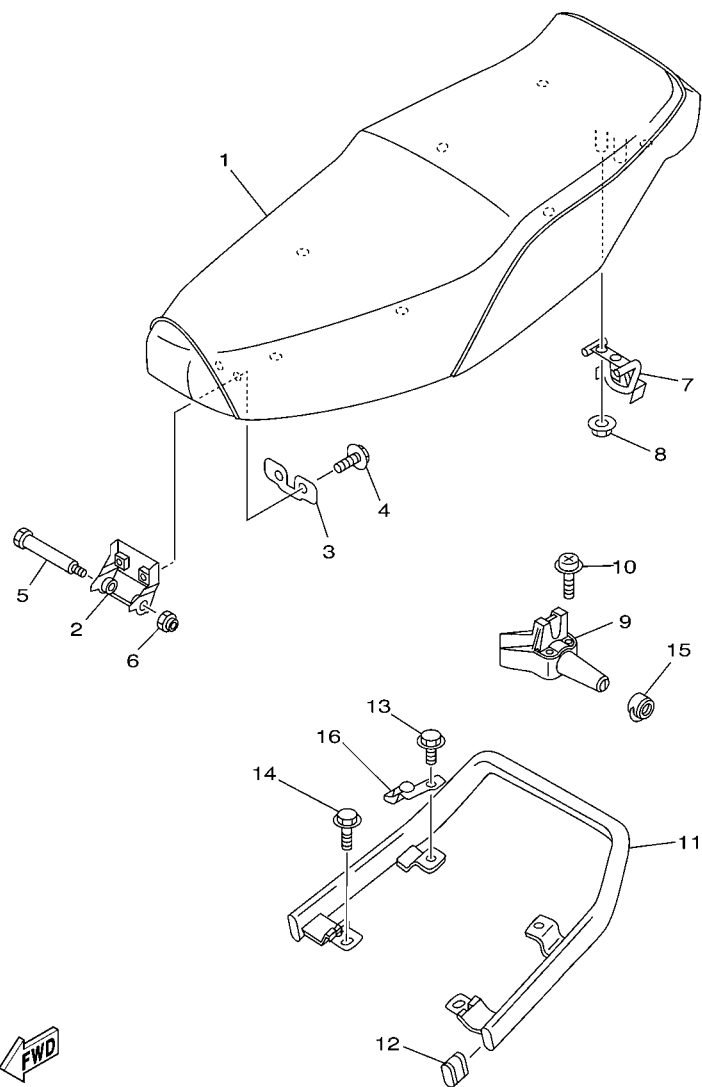

  
5AV5450-C240

REF. NO.	PART NO. CODIGO Nº	DESCRIPTION DESCRIPCION	1D81	1D82	REMARKS OBSERVACIONES
1	5AV-F4730-10	DOUBLE SEAT ASSY SILLIN DOBLE COMPLETO		1	
2	5AV-F4726-00	HINGE, SEAT HINGE SEAT		1	
3	5AV-F4744-00	PLATE, SEAT FITTING PLACA ACCESORIA DE ASIENTO		1	
4	90119-06044	BOLT, WITH WASHER TORNILLO CON ARANDELA		2	
5	90109-065E0	BOLT PERNO		1	
6	95607-06100	NUT, U TUERCA AUTOBLOCANTE		1	
7	5AV-F4728-00	BRACKET, SEAT SOPORTE DE ASIENTO		1	
8	95707-06500	NUT, FLANGE TUERCA DE BRIDA		2	
9	5AV-F4705-00	SEAT LOCK ASSY CIERRE DE SILLIN COMPLETO		1	
10	90159-06064	SCREW, WITH WASHER TORNILLO CON VALONA		2	
11	5AV-F4773-00	HANDLE, SEAT MANIJA DE ASIENTO		1	
12	5AV-F4742-00	GROMMET ANILLO PROTECTOR		2	
13	95827-06012	BOLT, FLANGE TUERCA DE REBORDE		2	
14	95827-06016	BOLT, FLANGE TUERCA DE REBORDE		2	
15	5AV-F4796-00	COVER CUBIERTA		1	
16	5AV-F1308-00	HELMET HANGER ASSY PORTACASCO COMPLETO		1	

FIG. 26 FRONT WHEEL

RUEDA DELANTERA

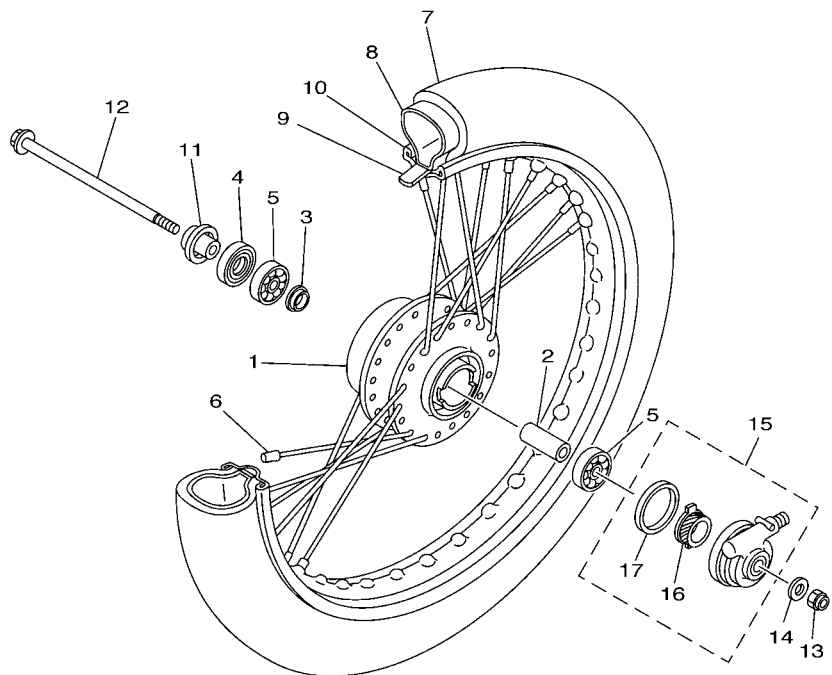

REF. NO.	PART NO. CODIGO Nº	DESCRIPTION DESCRIPCION	1D81	1D82	REMARKS OBSERVACIONES
1	5AV-F5111-10-WN	HUB, FRONT MASA DELANTERA	1	1	CIS
2	47V-F5117-00	SPACER, BEARING ESPACIADOR DE COJINETE	1	1	CIS
3	47V-F5115-00	FLANGE, SPACER 1 BRIDA DE ESPACIADOR 1	1	1	
4	93106-20802	OIL SEAL RETEN DE ACEITE	1	1	
5	93306-300Y1	BEARING COJINETE	2	2	
6	5AV-F5104-00	SPOKE SET, FRONT JUEGO DE RAYOS DELANTERO	1	1	
7	94122-17849	TIRE (2.50-17) NEUMATICO (2.50-17)	1	1	
8	94222-17830	TUBE (2.50-17) TUBO (2.50-17)	1	1	
9	94322-17827	BAND, RIM (2.50/2.75-17) BANDA DE ARO (2.50/2.75-17)	1	1	
10	94414-17888	RIM (1.40-17) ARO (1.40-17)	1	1	
11	5AV-F5183-00	COLLAR, WHEEL COLLAR DE RUEDA	1	1	
12	5AV-F5181-00	AXLE, WHEEL EJE DE LA RUEDA	1	1	
13	90185-10091	NUT, SELF-LOCKING TUERCA AUTOBLOCANTE	1	1	
14	90201-101J1	WASHER, PLATE ARANDELA PLANA	1	1	
15	5BU-F5190-00	GEAR UNIT ASSY UNIDAD DE ENGRANAJE COMPLETA	1	1	
16	5BU-F5135-00	.GEAR, DRIVE .ENGRANAJE DE TRACCION	1	1	
17	93109-40047	.OIL SEAL .SELLO ACEITE	1	1	

  
1D81210-C260

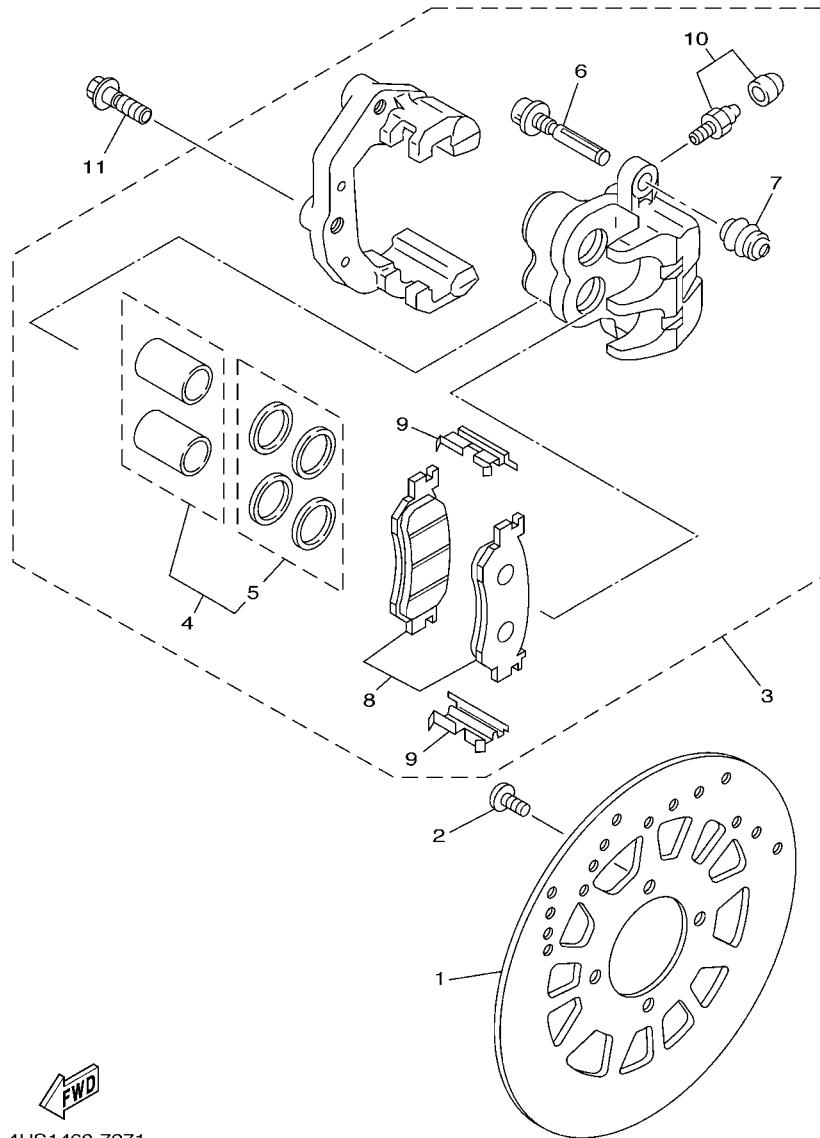

**FWD**  
4US1460-7271

**FIG. 27 FRONT BRAKE CALIPER**

**CALIBRE FRENO DELANTERA**

REF. NO.	PART NO. CODIGO Nº	DESCRIPTION DESCRIPCION	1D81	1D82	REMARKS OBSERVACIONES
1	4NS-F582U-00	DISC, BRAKE (RIGHT) DISCO DE FRENO (DERECO)	1	1	
2	90109-081F0	BOLT PERNO	4	4	
3	4US-F580U-00	CALIPER ASSY (RIGHT) CALIBRE COMPLETO (DERECO)	1	1	
4	4TT-W0057-00	.PISTON ASSY, CALIPER .PISTON COMPLETO PINZA	1	1	
5	4ES-W0047-10	..CALIPER SEAL KIT ..JUEGO DE RETENES DE PINZA	1	1	
6	5JW-25914-00	.PIN, SLIDE .PASADOR	2	2	
7	4TT-25937-00	.BOOT 2 .FUNDA	2	2	
8	4US-W0045-00	.BRAKE PAD KIT .JUEGO DE COJIN DE FRENO	1	1	
9	4TT-25919-00	.SUPPORT, PAD .SOPORTE DE PASTILLAS	2	2	
10	51L-W0048-00	.BLEED SCREW KIT .CJTO TORNILLO DE PURGA	1	1	
11	90105-10638	BOLT, FLANGE TORNILLO	2	2	

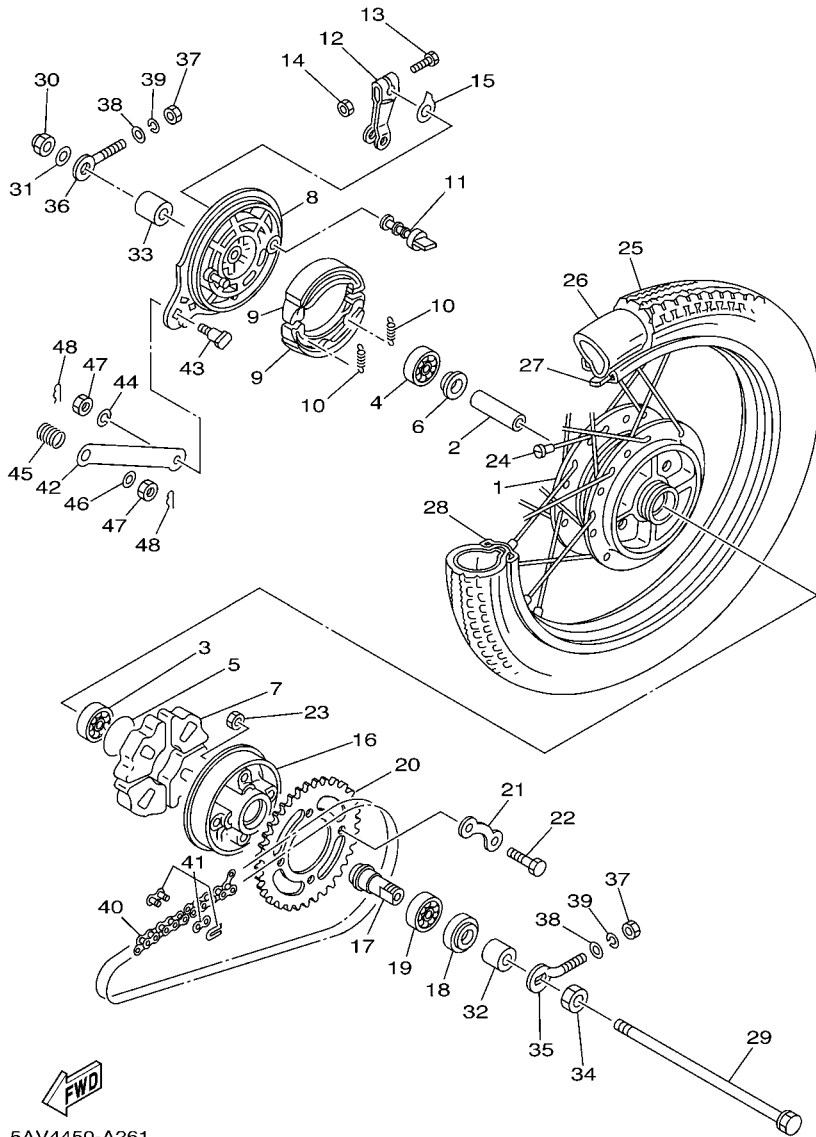

5AV4450-A261

FIG. 28 REAR WHEEL

RUEDA TRASERA

REF. NO.	PART NO. CODIGO Nº	DESCRIPTION DESCRIPCION	ID81	ID82	REMARKS OBSERVACIONES
1	5AV-F5311-00-WN	HUB, REAR MASA TRASERA	1	1	CIS CIS
2	90560-12812	SPACER SEPARADOR	1	1	
3	93306-301Y6	BEARING COJINETE	1	1	
4	93306-301Y5	BEARING COJINETE	1	1	
5	93210-41817	O-RING ANILLO O	1	1	
6	47V-F5315-00	FLANGE, SPACER SEPARADOR	1	1	
7	47V-F5364-00	DAMPER AMORTIGUADOR	4	4	
8	47V-F5321-00-WN	PLATE, BRAKE SHOE PLACA DE ZAPATA DE FRENO	1	1	CIS CIS
9	47V-F5330-00	BRAKE SHOE COMP. ZAPATA DE FRENO COMPLETA	2	2	
10	90506-18812	SPRING, TENSION RESORTE DE TENSION	2	2	
11	47V-F5351-00	CAMSHAFT ARBOL DE LEVAS	1	1	
12	47V-F5355-00	LEVER, CAMSHAFT PALANCA DE ARBOL DE LEVAS	1	1	
13	90101-06822	BOLT TORNILLO	1	1	
14	95307-06600	NUT TUERCA	1	1	
15	47V-F533A-00	PLATE, INDICATOR PLACA INDICADOR	1	1	
16	47V-F5366-00	CLUTCH, HUB EMBRAGUE DE MASA	1	1	
17	5AV-F5387-00	AXLE, SPROCKET EJE DE CORONA	1	1	
18	93106-30004	OIL SEAL RETEN DE ACEITE	1	1	
19	93306-004Y1	BEARING COJINETE	1	1	
20	5AV-F5437-00	SPROCKET, DRIVEN (37T) CORONA (37T)	1	1	
21	47V-F5412-01	WASHER ARANDELA	2	2	
22	90101-08672	BOLT TORNILLO	4	4	
23	90179-08168	NUT TUERCA	4	4	
24	47V-F5304-00	SPOKE SET, REAR JUEGO DE RAYOS TRASEROS	1	1	
25	94125-17852	TIRE (2.75-17) NEUMATICO (2.75-17)	1	1	
26	94225-17831	TUBE (2.75-17) TUBO (2.75-17)	1	1	
27	94322-17827	BAND, RIM (2.50/2.75-17) BANDA DE ARO (2.50/2.75-17)	1	1	

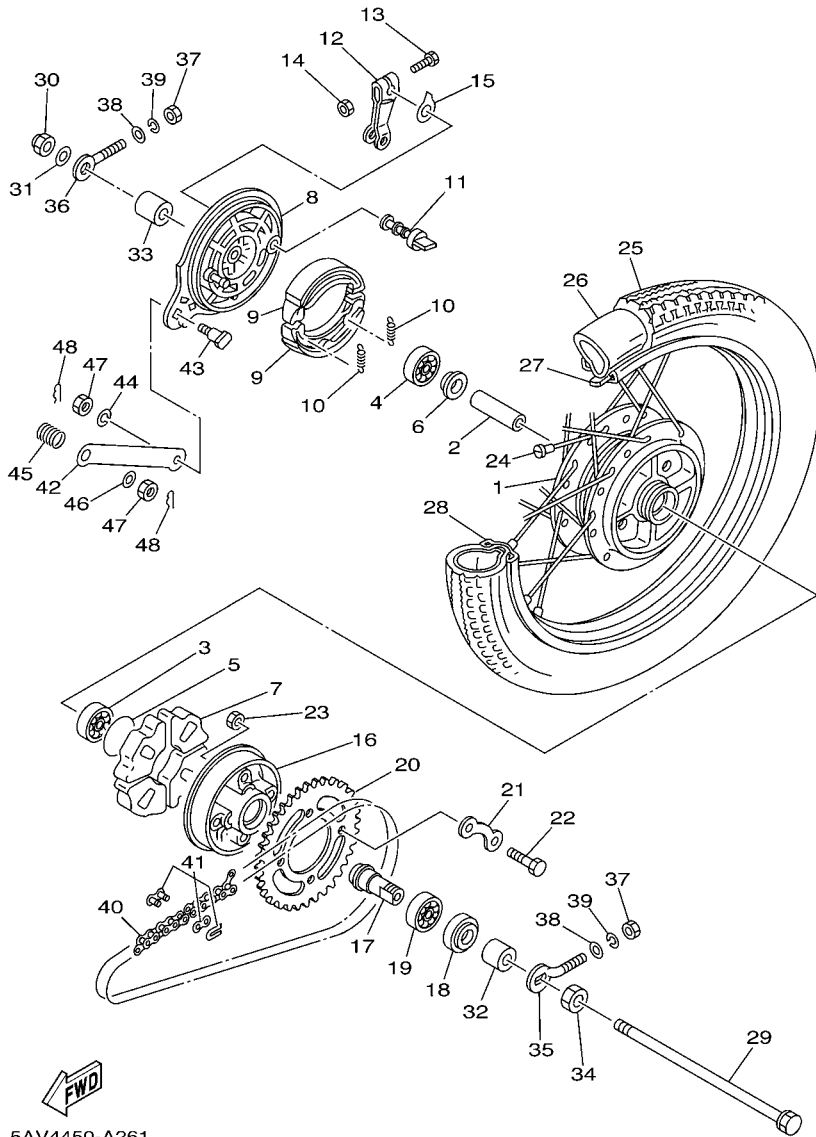

5AV4450-A261

FIG. 28 REAR WHEEL

RUEDA TRASERA

REF. NO.	PART NO. CODIGO Nº	DESCRIPTION DESCRIPCION	ID81	ID82	REMARKS OBSERVACIONES
28	94414-17837	RIM (1.40-17) ARO (1.40-17)	1	1	
29	5AV-F5381-01	AXLE, WHEEL EJE DE RUEDA	1	1	
30	90185-12046	NUT, SELF-LOCKING TUERCA AUTOBLOCANTE	1	1	
31	90201-12688	WASHER, PLATE ARANDELA PLANA	1	1	
32	90387-121U1	COLLAR COLLAR	1	1	
33	90387-181U2	COLLAR COLLAR	1	1	
34	90170-18165	NUT TUERCA	1	1	
35	47V-F5388-00	PULLER, CHAIN 1 TIRADOR DE CADENA 1	1	1	
36	47V-F5389-00	PULLER, CHAIN 2 TIRADOR DE CADENA 2	1	1	
37	95307-06600	NUT TUERCA	2	2	
38	90201-061A5	WASHER, PLATE ARANDELA PLANA	2	2	
39	92907-06100	WASHER, SPRING ARANDELA	2	2	
40	94568-39097	CHAIN CADENA	1	1	
41	94668-37001	JOINT, CHAIN (DID 428) CONECTOR DE CADENA (DID 428)	1	1	
42	47V-F5371-00	BAR, TENSION BARRA TENSORA	1	1	
43	90109-08183	BOLT PERNO	1	1	
44	92907-08100	WASHER, SPRING ARANDELA	1	1	
45	90501-205E8	SPRING, COMPRESSION RESORTE DE COMPRESION	1	1	
46	90201-087F0	WASHER, PLATE ARANDELA PLANA	1	1	
47	95307-08700	NUT TUERCA	2	2	
48	90468-12007	CLIP PRESILLA	2	2	

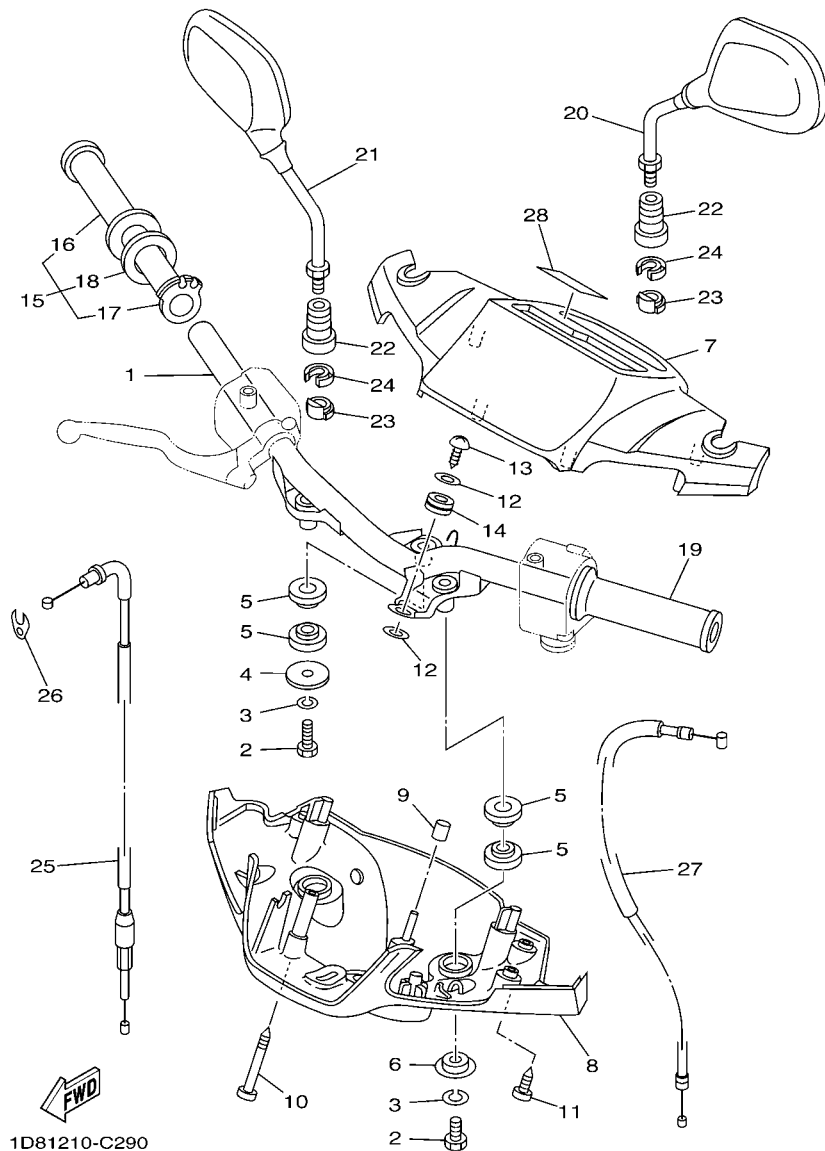
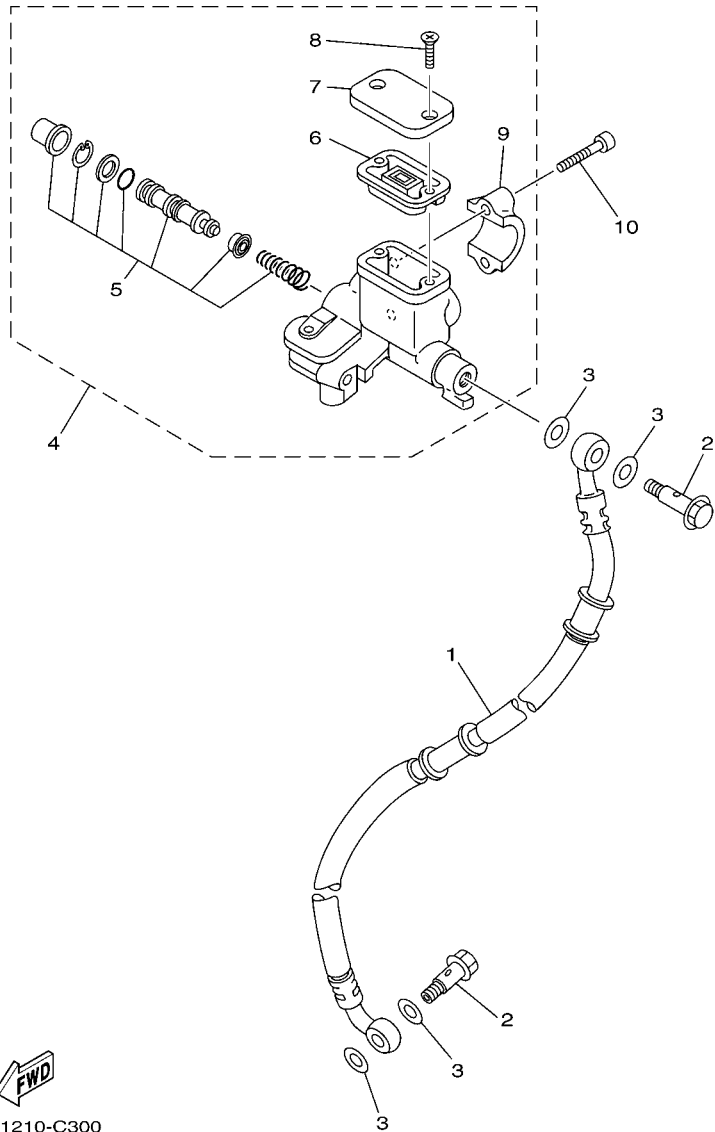

FIG. 29 STEERING HANDLE & CABLE MANILLAR & CABLE

REF. NO.	PART NO. CODIGO N°	DESCRIPTION DESCRIPCION	1D81	1D82	REMARKS OBSERVACIONES
1	5AV-F6210-00	HANDLE MANUBRIO	1	1	
2	97007-08016	BOLT PERNO	3	3	
3	92907-08100	WASHER, SPRING ARANDELA	3	3	
4	90201-08612	WASHER, PLATE ARANDELA PLANA	1	1	
5	5AV-F6113-00	DAMPER AMORTIGUADOR	6	6	
6	5AV-F6129-00	WASHER ARANDELA	2	2	
7	5AV-F6213-10-P2	COVER, UPPER CUBIERTA SUPERIOR	1	1	UR VRC1 UR VRC1
	5AV-F6213-10-P3	COVER, UPPER CUBIERTA SUPERIOR	1	1	UR DPBMC UR DPBMC
8	5AV-F6215-00-P2	COVER, LOWER CUBIERTA INFERIOR	1	1	UR VRC1 UR VRC1
	5AV-F6215-00-P3	COVER, LOWER CUBIERTA INFERIOR	1	1	UR DPBMC UR DPBMC
9	5AV-F622F-00	DAMPER, LOCATING 1 AMORTIGUADOR, DE UBICACION 1	1	1	
10	90167-04033	SCREW, TAPPING TORNILLO DE ROSCA HEMBRA	2	2	
11	97707-50016	SCREW, TAPPING TORNILLO ROSCA HEMBRA	3	3	
12	92907-10200	WASHER, PLAIN ARANDELA	2	2	
13	97707-50014	SCREW, TAPPING TORNILLO ROSCA HEMBRA	1	1	
14	90480-01321	GROMMET TAPON	1	1	
15	5AV-F6240-00	GRIP ASSY EMPUNADURA COMPLETA	1	1	
16	5AV-F6242-00	.GRIP (RIGHT) .EMPUNADURA (MD)	1	1	
17	5AV-F6243-00	.TUBE, THROTTLE GUIDE .TUBO DE GUIA DE OBTURADOR	1	1	
18	90201-261L1	.WASHER, PLATE .ARANDELA PLANA	1	1	
19	5AV-F6241-00	GRIP EMPUNADURA	1	1	
20	5AV-F6280-00	REAR VIEW MIRROR ASSY (LEFT) ESPEJO COMPLETO (IZQUIERDO)	1	1	
21	5AV-F6290-00	REAR VIEW MIRROR ASSY (RIGHT) ESPEJO COMPLETO (DERECHO)	1	1	
22	5AV-F629T-00	BOOT 1 FUNDA 1	2	2	
23	5AV-F6326-00	GROMMET TAPON PROTECTOR	2	2	
24	5AV-F6129-00	WASHER ARANDELA	2	2	
25	5AV-F6311-00	CABLE, THROTTLE 1 CABLE DE ACELERADOR 1	1	1	





1D81210-C300

FIG. 30 FRONT MASTER CYLINDER CILINDRO MAESTRO DELANTERO

REF. NO.	PART NO. CODIGO Nº	DESCRIPTION DESCRIPCION	1D81	1D82	REMARKS OBSERVACIONES
1	4US-F5872-00	HOSE, BRAKE 1 MANGUERA DE FRENO 1	1	1	
2	90401-10159	BOLT, UNION PERNO DE UNION	2	2	
3	90201-10118	WASHER, PLATE ARANDELA PLANA	4	4	
4	5LM-F583T-00	MASTER CYLINDER ASSY CILINDRO MAESTRO COMPLETO	1	1	
5	3RW-W0041-02	.CYLINDER KIT, MASTER .JUEGO DE CILINDRO MAESTRO	1	1	
6	3YR-25854-00	.DIAPHRAGM, RESERVOIR .DIAFRAGMA TANQUE RESERVA	1	1	
7	3YR-25852-00	.CAP, RESERVOIR .TAPA DE TANQUE DE RESERVA	1	1	
8	36Y-2589H-00	.SCREW .TORNILLO	2	2	
9	3YK-25876-00	.HOLDER, BRAKE HOSE 2 .SOPORTE DE MANGUERA FRENO 2	1	1	
10	91317-06025	BOLT PERNO	2	2	

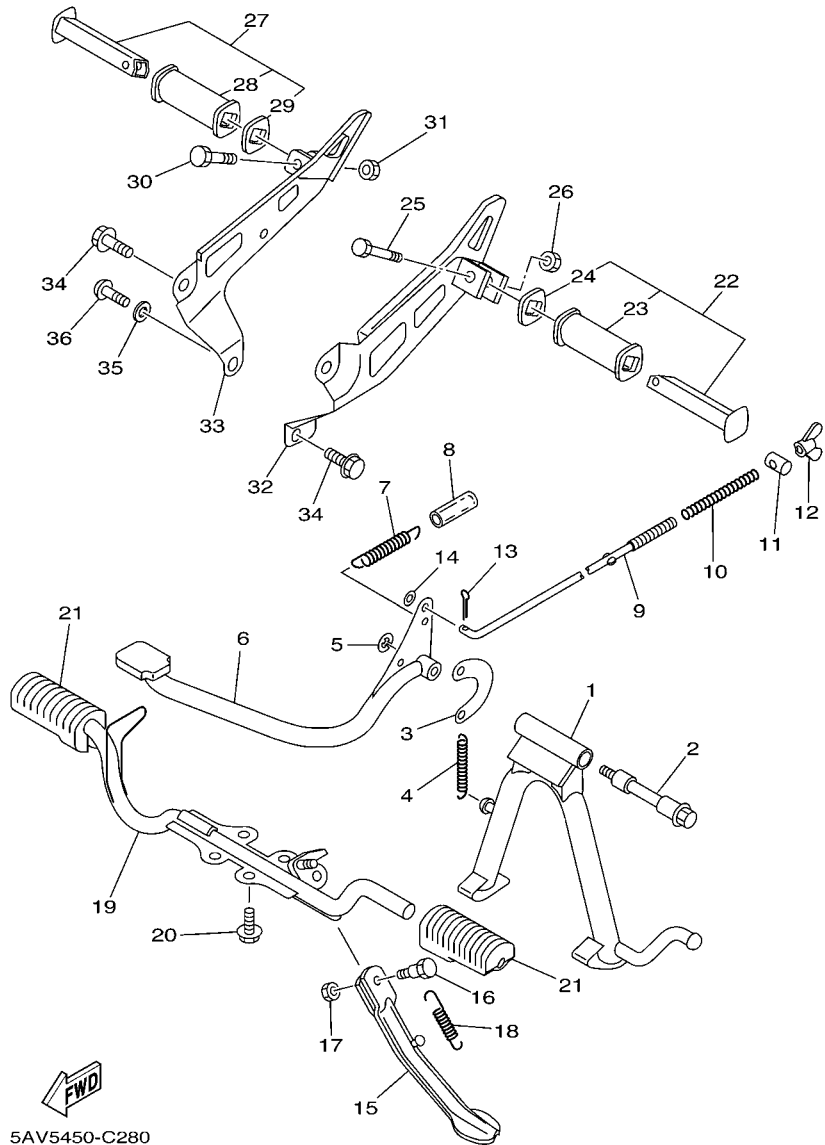

5AV5450-C280

FIG. 31 STAND & FOOTREST

SOPORTE & APOYAPIE

REF. NO.	PART NO. CODIGO Nº	DESCRIPTION DESCRIPCION	1D81	1D82	REMARKS OBSERVACIONES
1	5AV-F7111-00	STAND, MAIN PUNTAL PRINCIPAL	1	1	
2	5AV-F7112-00	SHAFT, MAIN STAND EJE DE PUNTAL PRINCIPAL	1	1	
3	5AV-F7115-00	LINK, MAIN STAND CONEXION DE PUNTAL PRINCIPAL	1	1	
4	90506-29054	SPRING, TENSION RESORTE DE TENSION	1	1	
5	93430-12008	CIRCLIP SEGURO	1	1	
6	5AV-F7211-00	PEDAL, BRAKE PEDAL DE FRENO	1	1	
7	90506-20041	SPRING, TENSION RESORTE DE TENSION	1	1	
8	5AV-F7235-00	COVER, DUST CUBIERTA DE POLVO	1	1	
9	5AV-F7231-00	ROD, BRAKE VARILLA DE FRENO	1	1	
10	90501-10245	SPRING, COMPRESSION RESORTE DE COMPRESION	1	1	
11	90249-12008	PIN PASADOR	1	1	
12	90175-06013	NUT, WING TUERCA MARIPOSA	1	1	
13	91401-20012	PIN, COTTER PASADOR DE CHAVETA	1	1	
14	92907-06600	WASHER, PLATE ARANDELA	1	1	
15	5AV-F7311-00	STAND, SIDE PUNTAL LATERAL	1	1	
16	90109-08034	BOLT PERNO	1	1	
17	95307-08700	NUT TUERCA	1	1	
18	90506-25047	SPRING, TENSION RESORTE DE TENSION	1	1	
19	5AV-F7411-00	FOOTREST 1 APOYAPIE 1	1	1	
20	95827-08016	BOLT, FLANGE TUERCA DE REBORDE	4	4	
21	5AV-F7413-00	COVER, FOOTREST CUBIERTA DE APOYAPIE	2	2	
22	5AV-F7430-00	REAR FOOTREST ASSY 1 APOYAPIE POSTERIOR COMPLETO 1	1	1	
23	5AV-F7433-00	COVER, REAR FOOTREST CUBIERTA APOYAPIE TRASERO	1	1	
24	90209-18070	WASHER ARANDELA DE SEPARACION	1	1	
25	90109-066F1	BOLT PERNO	1	1	
26	95607-06100	NUT, U TUERCA AUTOBLOCANTE	1	1	
27	5AV-F7440-00	REAR FOOTREST ASSY 2 APOYAPIE POSTERIOR COMPLETO 2	1	1	



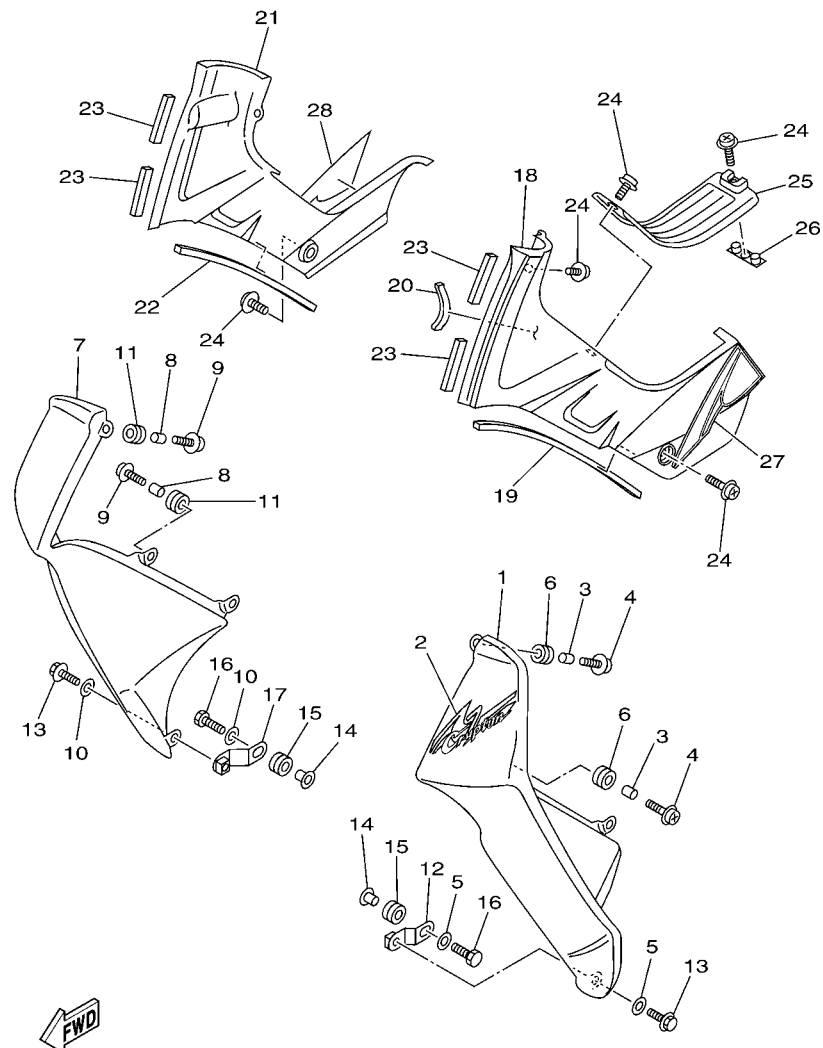

5AV5450-C290

FIG. 32 LEG SHIELD

PATA PROTEGIDA

REF. NO.	PART NO. CODIGO Nº	DESCRIPTION DESCRIPCION	ID81	ID82	REMARKS OBSERVACIONES
1	5AV-F8311-20-P2	LEG SHIELD 1 PROTECCION DE PATA 1	1	1	UR VRC1 UR VRC1
	5AV-F8311-20-P3	LEG SHIELD 1 PROTECCION DE PATA 1	1	1	UR DPBMC UR DPBMC
2	5AV-F8368-60	EMBLEM EMBLEMA	1	1	UR FOR VRC1 UR PARA VRC1
	5AV-F8368-70	EMBLEM EMBLEMA	1	1	UR FOR DPBMC UR PARA DPBMC
3	90387-060G7	COLLAR COLLAR	2	2	
4	90159-06085	SCREW, WITH WASHER TORNILLO CON VALONA	2	2	
5	90201-06557	WASHER, PLATE ARANDELA PLANA	2	2	
6	90480-13398	GROMMET TAPON	2	2	
7	5AV-F8312-20-P2	LEG SHIELD 2 PROTECCION DE PATA 2	1	1	UR VRC1 UR VRC1
	5AV-F8312-20-P3	LEG SHIELD 2 PROTECCION DE PATA 2	1	1	UR DPBMC UR DPBMC
8	90387-060G7	COLLAR COLLAR	2	2	
9	90159-06085	SCREW, WITH WASHER TORNILLO CON VALONA	2	2	
10	90201-06557	WASHER, PLATE ARANDELA PLANA	2	2	
11	90480-13398	GROMMET TAPON	2	2	
12	5AV-F8321-00	STAY 1 SOPORTE	1	1	
13	95807-06014	BOLT, FLANGE TUERCA DE REBORDE	2	2	
14	90560-06201	SPACER SEPARADOR	2	2	
15	90480-13018	GROMMET TAPON	2	2	
16	97007-06020	BOLT PERNO	2	2	
17	5AV-F8322-00	STAY 2 SOPORTE 2	1	1	
18	5AV-F8385-00-P2	COVER, LOWER CUBIERTA INFERIOR	1	1	UR VRC1 UR VRC1
	5AV-F8385-00-P3	COVER, LOWER CUBIERTA INFERIOR	1	1	UR DPBMC UR DPBMC
19	5AV-F8435-00	DAMPER 4 AMORTIGUADOR 4	1	1	
20	5AV-F834W-00	PROTECTOR 2 PROTECTOR 2	1	1	
21	5AV-F8395-00-P2	COVER, UNDER CUBIERTA INFERIOR	1	1	UR VRC1 UR VRC1
	5AV-F8395-00-P3	COVER, UNDER CUBIERTA INFERIOR	1	1	UR DPBMC UR DPBMC
22	5AV-F8435-00	DAMPER 4 AMORTIGUADOR 4	1	1	

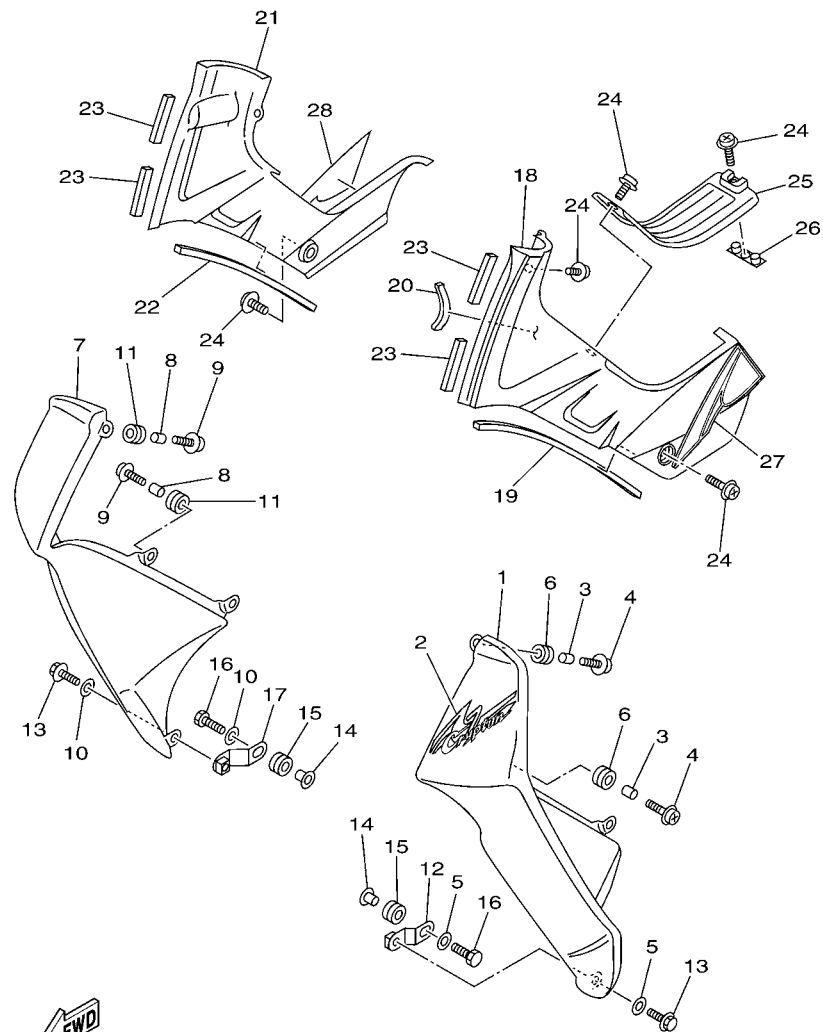

**FWD**  
5AV5450-C290

**FIG. 32 LEG SHIELD**

**PATA PROTEGIDA**

REF. NO.	PART NO. CODIGO Nº	DESCRIPTION DESCRIPCION	1D81	1D82	REMARKS OBSERVACIONES
23	5AV-F3398-00	MOLD, FRONT MOLDURA DELANTERA	4	4	
24	90159-06181	SCREW, WITH WASHER TORNILLO CON VALONA	5	5	
25	5AV-F834V-00	PROTECTOR 1 PROTECTOR 1	1	1	
26	5AV-F836T-00	DAMPER, LOCATING 1 AMORTIGUADOR DE MONTAJE 1	1	1	
27	5AV-F8391-60	GRAPHIC 1 CALCOMANIA DE BOVEDA 1	1	1	UR FOR VRC1 UR PARA VRC1
	5AV-F8391-70	GRAPHIC 1 CALCOMANIA DE BOVEDA 1	1	1	UR FOR DPBMC UR PARA DPBMC
28	5AV-F8392-60	GRAPHIC 2 CALCOMANIA DE BOVEDA 2	1	1	UR FOR VRC1 UR PARA VRC1
	5AV-F8392-70	GRAPHIC 2 CALCOMANIA DE BOVEDA 2	1	1	UR FOR DPBMC UR PARA DPBMC



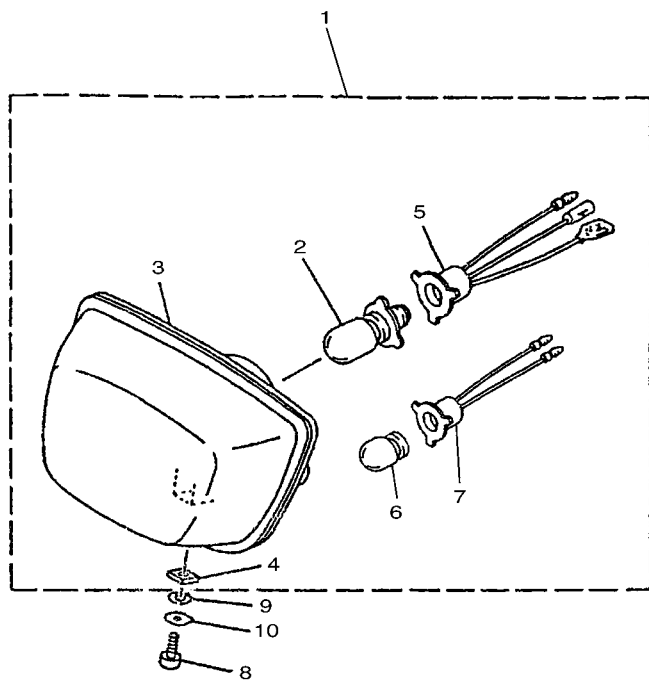





FIG. 37 HEADLIGHT

FARO DELANTERO



REF. NO.	PART NO. CODIGO Nº	DESCRIPTION DESCRIPCION	1D81	1D82		REMARKS OBSERVACIONES
1	1D8-H4310-00	HEADLIGHT UNIT ASSY UNIDAD DE FARO DELANTERO COMPL	1	1		
2	5AV-H4314-00	.BULB, HEADLIGHT .BOMBILLA DE FARO DELANTERO	1	1		
3	1D8-H4120-00	.LENS ASSY .LENTES COMPLETO	1	1		
4	5AV-H4317-00	.NUT .TUERCA	1	1		
5	1D8-H4140-00	.SOCKET CORD ASSY .ENCASTRE DE CABLE COMPLETO	1	1		
6	5AV-H4347-00	.BULB .BOMBILLA	1	1		
7	5AV-H4150-00	.SOCKET CORD ASSY 2 .ENCASTRE DE CABLE COMPLETO 2	1	1		
8	97007-06012	BOLT PERNO	1	1		
9	90201-06557	WASHER, PLATE ARANDELA PLANA	1	1		
10	90206-06088	WASHER, WAVE ARANDELA ONDULADA	1	1		



5AV4450-A340

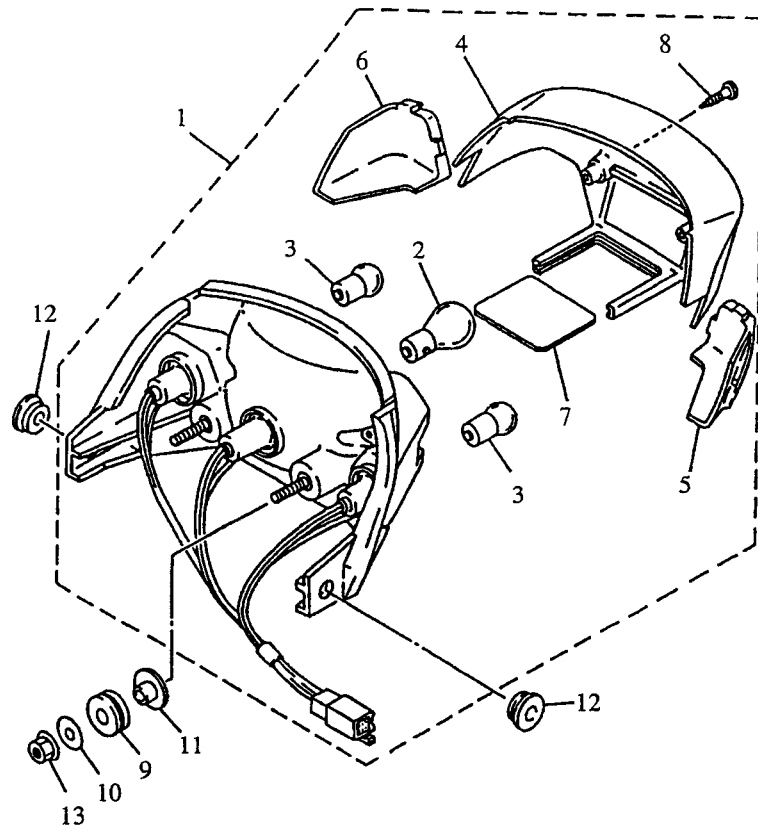

FIG. 38 TAILLIGHT

LUZ DE COLA

REF. NO.	PART NO. CODIGO Nº	DESCRIPTION DESCRIPCION	1D81	1D82	REMARKS OBSERVACIONES
1	5AV-H4710-00	TAILLIGHT UNIT ASSY CONJT. FARO TRASERO	1	1	
2	5AV-H4714-00	.BULB, TAILLIGHT (12V-21/5W) .BOMBILLA (12V-21/5W)	1	1	
3	5AV-H3311-00	.BULB, FLASHER (12V-10W) .BOMBILLA (12V-10W)	2	2	
4	5AV-H4721-00	.LENS, TAILLIGHT .LENTE DE FARO TRASERO	1	1	
5	5AV-H3332-00	.LENS, FLASHER .LENTE DE DESTELLADOR	1	1	
6	5AV-H3342-00	.LENS, FLASHER 2 .LENTE DE DESTELLADOR	1	1	
7	5AV-H4743-00	.LENS, LICENCE LIGHT .LENTE DE LUZ DE LICENCIA	1	1	
8	97706-40625	.SCREW, TAPPING .TORNILLO, ROSCA CHAPA	2	2	LM LM
9	90480-18881	GROMMET TAPON	2	2	
10	90201-06071	WASHER, PLATE ARANDELA PLANA	2	2	
11	90387-066M1	COLLAR COLLAR	2	2	
12	90480-13426	GROMMET TAPON	2	2	
13	95707-06500	NUT, FLANGE TUERCA DE BRIDA	2	2	



5AV4450-A350



FIG. 40 ELECTRICAL 1

EQUIPO ELECTRICO 1

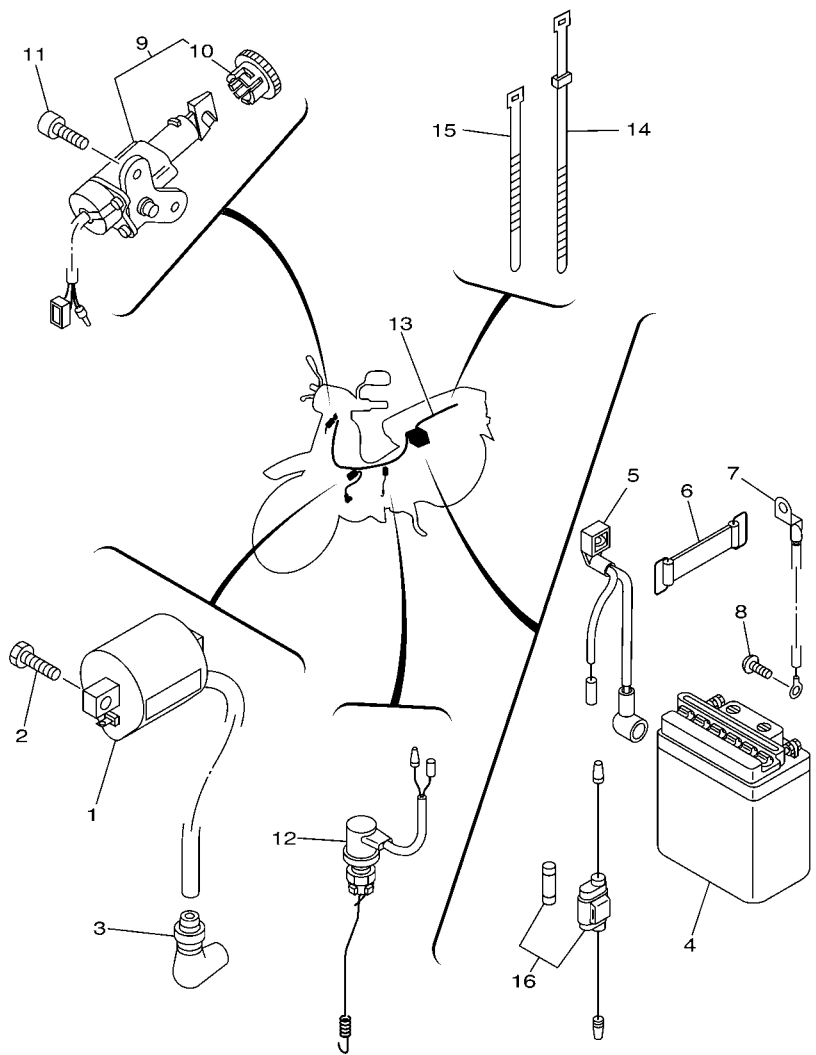

5AV5450-C370

REF. NO.	PART NO. CODIGO Nº	DESCRIPTION DESCRIPCION	1D81	1D82	REMARKS OBSERVACIONES
1	5AV-H2310-00	IGNITION COIL ASSY BOBINA DE ENCENDIDO COMPLETA	1	1	
2	97007-06016	BOLT PERNO	2	2	
3	5AV-H2370-00	PLUG CAP ASSY TAPON DE BUJIA COMPLT	1	1	
4	5AV-H2110-00	BATTERY ASSY (GM5Z-3B) BATERIA COMPLETA (GM5Z-3B)	1	1	
5	5AV-H2115-00	WIRE, PLUS LEAD CABLE CONDUCTOR POSITIVO	1	1	
6	5AV-H2131-00	BAND, BATTERY TIRANTE DE BATERIA	1	1	
7	5AV-H2116-00	WIRE, MINUS LEAD CABLE CONDUCTOR NEGATIVO	1	1	
8	97607-05210	SCREW, WITH WASHER TORNILLO CAB CON PLANA C/ARAN	1	1	
9	5AV-H2501-00	MAIN SWITCH STEERING LOCK LLAVE DE IGNICION COMPLT	1	1	
10	5AV-H2552-00	.CAP, SWITCH .TAPA DE INTERRUPTOR	1	1	
11	91317-06012	BOLT PERNO	2	2	
12	5AV-H2530-00	STOP SWITCH ASSY INTERRUPTOR DE PARADA COMPLETO	1	1	
13	5AV-H2590-10	WIRE HARNESS ASSY CONJUNTO DE CABLES	1	1	
14	5AV-H3936-00	BAND, SWITCH CORD BANDA DE CABLE DE INTERRUPTOR	2	2	
15	5AV-H3936-10	BAND, SWITCH CORD BANDA DE CABLE DE INTERRUPTOR	2	2	
16	5AV-H2150-00	FUSE HOLDER ASSY PORTA-FUSIBLES COMPLETO	1	1	

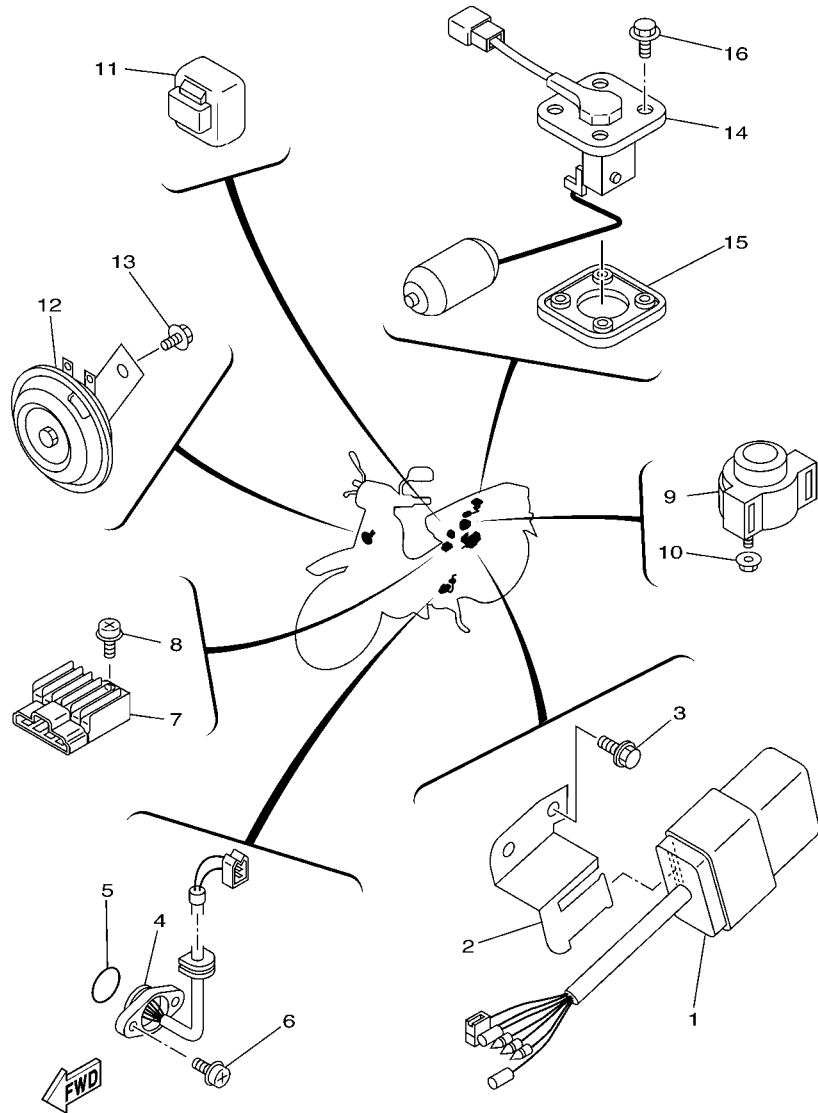

5AV4450-A381

FIG. 41 ELECTRICAL 2

EQUIPO ELECTRICO 2

REF. NO.	PART NO. CODIGO Nº	DESCRIPTION DESCRIPCION	1D81	1D82	REMARKS OBSERVACIONES
1	5AV-H5540-10	C.D.I. UNIT ASSY UNIDAD C.D.I. COMPLETA	1	1	
2	5AV-F1274-00	BRACKET, C.D.I. UNIT SOPORTE DE UNIDAD C.D.I.	1	1	
3	90119-06044	BOLT, WITH WASHER TORNILLO CON ARANDELA	1	1	
4	5AV-H2540-00	NEUTRAL SWITCH ASSY INTERRUPTOR NEUTRAL COMPL	1	1	
5	93210-22382	O-RING ANILLO O	1	1	
6	97607-05216	SCREW, WITH WASHER TORNILLO CAB CON PLANA C/ARAN	2	2	
7	5AV-H1960-00	RECTIFIER & REGULATOR ASSY RECTIFICADOR Y REGULADOR	1	1	
8	97607-06216	SCREW, WITH WASHER TORNILLO CAB CON PLANA C/ARAN	1	1	
9	5AV-H1940-00	STARTER RELAY ASSY CONJUNTO ARRANCADOR RELEVO	1	1	
10	95707-06500	NUT, FLANGE TUERCA DE BRIDA	2	2	
11	5AV-H3350-00	FLASHER RELAY ASSY RELE DE DESTELLADOR COMPL.	1	1	
12	5AV-H3371-V0	HORN BOCINA	1	1	
13	95807-06010	BOLT, FLANGE TUERCA DE REBORDE	1	1	
14	5AV-H5752-00	SENDER UNIT ASSY, FUEL METER UNIDAD TRANSM MED.COMBUST.	1	1	
15	5AV-H5753-00	GASKET, SENDER UNIT EMPAQUE DE UNIDAD TRANSMISORA	1	1	
16	90119-05071	BOLT, WITH WASHER TORNILLO CON ARANDELA	4	4	

NUMERICAL INDEX  
INDICE NUMERICO

PART NO. CODIGO N°	REF. NO.	PART NO. CODIGO N°	REF. NO.	PART NO. CODIGO N°	REF. NO.	PART NO. CODIGO N°	REF. NO.	PART NO. CODIGO N°	REF. NO.	PART NO. CODIGO N°	REF. NO.
4SV-12119-00	3 - 3	5AV-E2231-00	4 - 12	5AV-E5121-00	9 - 2	5AV-E817A-00	16 - 19	5AV-F174X-01	19 - 15	5AV-F3391-00-P3	21 - 13
2JG-16324-00	13 - 15	5AV-E2241-00	4 - 13	5AV-E5316-00	9 - 13	5AV-E8181-00	16 - 14	5AV-F174Y-00	19 - 33	5AV-F3398-00	21 - 19
4ST-16586-00	13 - 5	5AV-E3300-00	5 - 1	5AV-E5362-00	10 - 18	5AV-E8186-00	16 - 20	5AV-F2110-00	20 - 1		32 - 23
4ST-16611-00	13 - 2	5AV-E3324-00	5 - 7	5AV-E5371-00	9 - 3	5AV-E8511-00	15 - 6	5AV-F2123-00	20 - 2	47V-F3411-00	21 - 4
5AV-23411-00	22 - 31	5AV-E3329-00	5 - 2	5AV-E5411-00	10 - 1	5AV-E8512-00	15 - 7	5AV-F2141-00	20 - 4	1KL-F3412-00	21 - 1
3YR-25852-00	30 - 7	5AV-E3411-00	5 - 6	5AV-E5418-00	10 - 12	5AV-E8531-00	15 - 5	5AV-F2151-00	20 - 3	47V-F3412-00	21 - 3
3YR-25854-00	30 - 6	5AV-E3451-00	5 - 8	5AV-E5421-10	10 - 15	5AV-E8531-10	16 - 18	5AV-F2210-00	20 - 10	5AV-F3415-00	21 - 7
3YK-25876-00	30 - 9	5AV-E3586-01	6 - 1	5AV-E5436-00	10 - 21	5AV-E8540-00	15 - 1	5AV-F2310-00	20 - 7	5AV-F3416-00	21 - 6
36Y-2589H-00	30 - 8	5AV-E3595-01	6 - 2	5AV-E5451-10	10 - 2	5AV-E8542-00	15 - 2	47V-F2315-00	20 - 9	5AV-F3461-00	21 - 20
5JW-25914-00	27 - 6	5AV-E4103-00	7 - 20	5AV-E5461-00	10 - 16	1D8-F1110-00	17 - 1	5AV-F3100-10	22 - 1	5AV-F4110-00	23 - 1
4TT-25919-00	27 - 9	5AV-E4104-00	7 - 21	5AV-E5492-00	10 - 14	5AV-F117F-00	17 - 6	5AV-F3102-10	22 - 2	5LK-F413B-00	29 - 28
4TT-25937-00	27 - 7	5AV-E410A-00	7 - 11	5AV-E5512-00	12 - 1	5AV-F117N-00	17 - 10	5AV-F3103-10	22 - 16	5AV-F4311-00	23 - 9
5AV-E1102-01	1 - 1	5AV-E4118-00	7 - 23	5AV-E5524-00	12 - 3	5AV-F1274-00	41 - 2	5AV-F3108-10	21 - 14	5AV-F4312-10	23 - 10
5AV-E1111F-00	4 - 5	5AV-E4197-00	7 - 24	5AV-E5580-20	12 - 5	5AV-F1308-00	25 - 16	5AV-F3110-00	22 - 6	5AV-F4313-00	23 - 11
5AV-E1134-00	1 - 2	5AV-E4301-00	7 - 1	5AV-E5583-00	12 - 6	1D8-F1376-00	17 - 13		22 - 20	5AV-F4500-00	23 - 14
5AV-E1161-00	1 - 5	5AV-E4312-25	7 - 17	5AV-E5618-00	11 - 13	5AV-F139R-00	17 - 5	5AV-F3111-00	22 - 14	5AV-F4514-00	23 - 2
5AV-E1166-00	9 - 4	5AV-E4323-00	7 - 6	5AV-E5620-00	11 - 12	5AV-F139X-00	17 - 7		22 - 28	5AV-F4602-V0	23 - 17
5AV-E1181-00	1 - 14	5AV-E4331-00	7 - 4	5AV-E5641-00	11 - 2	5AV-F1511-00-P2	18 - 1	5AV-F3122-00-P2	21 - 9	1D8-F461A-00	23 - 17
5AV-E1185-00	1 - 6	5AV-E4335-00	7 - 12	5AV-E5644-00	11 - 6	5AV-F1511-00-P3	18 - 1	5AV-F3122-00-P3	21 - 9	5AV-F4705-00	25 - 9
5AV-E1186-00	1 - 9	5AV-E4341-00	7 - 16		12 - 4	5AV-F1518-00	18 - 5	5AV-F3126-10	22 - 3	1D8-F4710-00	24 - 1
5AV-E1198-00	5 - 5	5AV-E4342-00	7 - 18	5AV-E5660-00	11 - 1	5AV-F160E-00	18 - 19	5AV-F3132-00-P2	21 - 10	1D8-F471N-00	24 - 9
5AV-E1311-00	1 - 17	14T-E4343-45	7 - 15	5AV-E5664-00	11 - 10	5AV-F1611-00	18 - 6	5AV-F3132-00-P3	21 - 10	5AV-F4726-00	24 - 2
5AV-E1351-01	1 - 19	4FP-E4349-00	7 - 8	5AV-E5671-00	11 - 4	5AV-F1629-00	18 - 15	5AV-F3136-10	22 - 17		25 - 2
5AV-E1400-20	2 - 1	5AV-E4384-00	7 - 2	5AV-E5676-00	11 - 8	5AV-F1638-00	18 - 18	5AV-F3141-00	22 - 12	5AV-F4728-00	25 - 7
5AV-E1412-00	2 - 2	5AV-E4385-00	7 - 3	5AV-E6150-00	13 - 13	1D8-F1653-00	17 - 12		22 - 26	5AV-F4730-10	25 - 1
5AV-E1422-00	2 - 6	6E5-E4386-01	7 - 9	5AV-E6321-00	13 - 16	5AV-F1685-00	18 - 12	5AV-F3144-00	22 - 11	5AV-F4742-00	25 - 12
5AV-E1500-00	2 - 14	5AV-E4390-00	7 - 22	5AV-E6351-00	13 - 17	5AV-F1711-00-P2	19 - 1		22 - 25	5AV-F4744-00	24 - 3
5AV-E1536-00	2 - 7	5AV-E4411-00	6 - 6	5AV-E6356-00	13 - 25	5AV-F1711-00-P3	19 - 1	5AV-F3145-00	22 - 4		25 - 3
5AV-E1610-00	2 - 13	5AV-E4412-00	6 - 8	5AV-E6357-00	13 - 24	5AV-F171E-00-P2	19 - 32		22 - 18	5AV-F4773-00	25 - 11
5AV-E1631-01	2 - 10	5AV-E4423-00	6 - 11	5AV-E6371-00	13 - 14	5AV-F171E-00-P3	19 - 32	5AV-F3147-00	22 - 10	1D8-F4796-00	18 - 24
5AV-E1633-00	2 - 11	5AV-E4433-00	6 - 12	5AV-E6512-00	13 - 4	5AV-F171M-00	19 - 5		22 - 24	5AV-F4796-00	25 - 15
5AV-E1651-00	2 - 5	5AV-E443E-00	6 - 15	5AV-E6620-00	13 - 8		19 - 10	5AV-F3152-00	22 - 8	1D8-F4810-00	24 - 7
5AV-E1681-00	2 - 3	5AV-E4451-00	6 - 7	5AV-E6626-00	13 - 9	5AV-F1721-00-P2	19 - 6		22 - 22	1D8-F4832-00	24 - 10
5AV-E2111-00	3 - 1	5AV-E4452-00	6 - 10	5AV-E7121-00	14 - 6	5AV-F1721-00-P3	19 - 6	5AV-F3156-00	22 - 5	1D8-F4833-00	24 - 12
5AV-E2114-00	3 - 4	5AV-E4453-00	6 - 9	5AV-E7131-00	14 - 2	1D8-F172W-00	19 - 16		22 - 19	1D8-F4846-00	18 - 21
5AV-E2117-00	3 - 6	5AV-E4472-01	6 - 13	5AV-E7141-00	14 - 3	5AV-F1730-00-P2	19 - 11	5AV-F3157-00	22 - 9	5AV-F5104-00	26 - 6
5AV-E2118-00	3 - 5	214-E4513-00	7 - 10	5AV-E7211-00	14 - 13	5AV-F1730-00-P3	19 - 11		22 - 23	5AV-F5111-10-WN	26 - 1
5AV-E2121-00	3 - 2	4JP-E4561-00	7 - 13	5AV-E7231-00	14 - 12	5AV-F1731-00-P2	19 - 12	5AV-F3158-L0	22 - 13	47V-F5115-00	26 - 3
5AV-E2126-00	3 - 7	5AV-E4594-00	7 - 14	5AV-E7241-00	14 - 11	5AV-F1731-00-P3	19 - 12		22 - 27	47V-F5117-00	26 - 2
5AV-E2151-00	3 - 8	5AV-E4610-00	8 - 1	5AV-E7402-00	14 - 10	5AV-F173E-60	19 - 13	5AV-F3170-00	22 - 7	5BU-F5135-00	26 - 16
5AV-E2156-00	3 - 11	5AV-E4613-00	8 - 8	5AV-E7411-00	14 - 1	5AV-F173E-70	19 - 13		22 - 21	5AV-F5181-00	26 - 12
5AV-E2159-00	3 - 9	5AV-E4628-00	8 - 2	5AV-E8101-00	16 - 1	5AV-F173F-60	19 - 27	5AV-F3181-50	22 - 15	5AV-F5183-00	26 - 11
5AV-E2170-00	4 - 1	5AV-E4651-00	1 - 4	5AV-E8110-00	16 - 23	5AV-F173F-70	19 - 27		22 - 29	5BU-F5190-00	26 - 15
5AV-E2171-00	4 - 2	5AV-E4766-00	8 - 3	5AV-E8120-00	15 - 4	5AV-F1740-00-P2	19 - 25		21 - 23	47V-F5304-00	28 - 24
5AV-E2176-00	4 - 8	5AV-E4781-00	8 - 6	5AV-E8140-00	16 - 8	5AV-F1740-00-P3	19 - 25	5AV-F331A-00	22 - 33	5AV-F5311-00-WN	28 - 1
5AV-E2190-00	4 - 11	5AV-E490J-00	7 - 19	5AV-E8152-00	16 - 2	5AV-F1741-00-P2	19 - 26	5AV-F3340-00	22 - 30	47V-F5315-00	28 - 6
5AV-E2210-00	4 - 15	5AV-E5111-00	9 - 1	5AV-E8172-00	16 - 15	5AV-F1741-00-P3	19 - 26	5AV-F3346-00	22 - 32	47V-F5321-00-WN	28 - 8
5AV-E2213-00	4 - 16	5AV-E5113-00	10 - 11	5AV-E8179-00	16 - 13	5AV-F174G-00	19 - 36	5AV-F3391-00-P2	21 - 13	47V-F5330-00	28 - 9

NUMERICAL INDEX  
INDICE NUMERICO

PART NO. CODIGO N°	REF. NO.	PART NO. CODIGO N°	REF. NO.	PART NO. CODIGO N°	REF. NO.	PART NO. CODIGO N°	REF. NO.	PART NO. CODIGO N°	REF. NO.	PART NO. CODIGO N°	REF. NO.
47V-F533A-00	28 - 15	5AV-F7413-00	31 - 21	5AV-H3311-00	35 - 3	90105-10778	20 - 14	90201-06071	38 - 10	90387-062M9	18 - 20
47V-F5351-00	28 - 11	5AV-F7430-00	31 - 22		35 - 7	90109-06577	39 - 4	90201-061A5	28 - 38	90387-06500	18 - 14
47V-F5355-00	28 - 12	5AV-F7433-00	31 - 23		38 - 3	90109-065E0	24 - 5	90201-06380	17 - 15		19 - 18
47V-F5364-00	28 - 7		31 - 28	5AV-H3312-00	35 - 2		25 - 5	90201-064K6	23 - 7		19 - 30
47V-F5366-00	28 - 16	5AV-F7440-00	31 - 27	5AV-H3320-00	35 - 5	90109-066F1	31 - 25	90201-06557	18 - 10	90387-06681	21 - 12
47V-F5371-00	28 - 42	5AV-F7452-00	31 - 32	5AV-H3322-00	35 - 6		31 - 30		32 - 5	90387-066M1	38 - 11
5AV-F5381-01	28 - 29	5AV-F7462-00	31 - 33	5AV-H3332-00	38 - 5	90109-08034	31 - 16		32 - 10	90387-06737	6 - 18
5AV-F5387-00	28 - 17	5AV-F8100-00	17 - 11	5AV-H3342-00	38 - 6	90109-08183	28 - 43		37 - 9		18 - 3
47V-F5388-00	28 - 35	5AV-F8311-20-P2	32 - 1	5AV-H3350-00	41 - 11	90109-081F0	27 - 2	90201-08326	4 - 9	90387-084N8	23 - 6
47V-F5389-00	28 - 36	5AV-F8311-20-P3	32 - 1	5AV-H3371-V0	41 - 12	90116-08597	9 - 12	90201-08609	1 - 11	90387-121U1	28 - 32
47V-F5412-01	28 - 21	5AV-F8312-20-P2	32 - 7	5AV-H3509-00	36 - 2	90119-05001	13 - 19	90201-08612	29 - 4	90387-1503D	14 - 14
5AV-F5437-00	28 - 20	5AV-F8312-20-P3	32 - 7	5AV-H3510-00	36 - 1	90119-05071	41 - 16	90201-086P8	17 - 3	90387-167L5	4 - 7
4US-F580U-00	27 - 3	5AV-F8321-00	32 - 12	5AV-H3517-00	36 - 3	90119-06044	18 - 7	90201-08766	23 - 8	90387-181U2	28 - 33
4NS-F582U-00	27 - 1	5AV-F8322-00	32 - 17	5AV-H3518-00	36 - 4		18 - 16	90201-087F0	28 - 46	90401-10159	30 - 2
5LM-F583T-00	30 - 4	5AV-F834V-00	32 - 25	5AV-H3550-10	36 - 6		24 - 4	90201-10118	30 - 3	90430-06014	4 - 17
4US-F5872-00	30 - 1	5AV-F834W-00	32 - 20	5AV-H3922-10	39 - 3		25 - 4	90201-101J1	26 - 14		10 - 17
5AV-F5886-00	21 - 25	5AV-F8368-60	32 - 2	5AV-H3936-00	40 - 14		41 - 3	90201-10591	13 - 26	90445-08170	18 - 17
5AV-F6113-00	29 - 5	5AV-F8368-70	32 - 2	5AV-H3936-10	40 - 15	90146-06011	18 - 25	90201-106F2	20 - 13	90460-43179	6 - 17
5AV-F6129-00	29 - 6	5AV-F836T-00	32 - 26	5AV-H3973-00	39 - 1	90149-06131	39 - 6	90201-12166	14 - 7	90465-08230	1 - 20
	29 - 24	5AV-F8385-00-P2	32 - 18	5AV-H3975-10	39 - 2	90149-06184	17 - 8	90201-12190	20 - 12	90465-10833	9 - 10
5AV-F6210-00	29 - 1	5AV-F8385-00-P3	32 - 18	1D8-H3980-00	39 - 9	90155-06007	5 - 3	90201-122H1	13 - 10	90467-07029	7 - 25
5AV-F6213-10-P2	29 - 7	5AV-F8391-60	32 - 27	1D8-H4120-00	37 - 3	90159-06064	25 - 10	90201-12688	28 - 31	90467-10008	23 - 12
5AV-F6213-10-P3	29 - 7	5AV-F8391-70	32 - 27	1D8-H4140-00	37 - 5	90159-06067	19 - 2	90201-126A7	16 - 17		23 - 13
5AV-F6215-00-P2	29 - 8	5AV-F8392-60	32 - 28	5AV-H4150-00	37 - 7		19 - 7	90201-127F4	16 - 10	90467-11106	6 - 16
5AV-F6215-00-P3	29 - 8	5AV-F8392-70	32 - 28	1D8-H4310-00	37 - 1	90159-06085	19 - 22	90201-15700	14 - 15	90467-13064	9 - 5
5AV-F622F-00	19 - 14	5AV-F8395-00-P2	32 - 21	5AV-H4314-00	37 - 2		32 - 4	90201-167P7	13 - 3	90468-12007	28 - 48
	19 - 28	5AV-F8395-00-P3	32 - 21	5AV-H4317-00	37 - 4		32 - 9	90201-174L9	13 - 20	90468-23194	11 - 3
	29 - 9	5AV-F8435-00	32 - 19	5AV-H4347-00	37 - 6	90159-06181	32 - 24	90201-20266	14 - 4	90480-01321	29 - 14
5AV-F6240-00	29 - 15		32 - 22	5AV-H4710-00	38 - 1	90167-04033	29 - 10	90201-20276	16 - 6	90480-10334	17 - 9
5AV-F6241-00	29 - 19	5AV-H1800-00	34 - 1	5AV-H4714-00	38 - 2	90167-05025	19 - 21	90201-261L1	29 - 18		19 - 19
5AV-F6242-00	29 - 16	5AV-H1828-00	34 - 4	5AV-H4721-00	38 - 4		19 - 35	90206-06088	37 - 10		19 - 31
5AV-F6243-00	29 - 17	5AV-H182L-00	34 - 2	5AV-H4743-00	38 - 7	90170-05302	3 - 10	90206-19027	11 - 5	90480-12314	18 - 2
5AV-F6280-00	29 - 20	5AV-H1861-00	34 - 3	5AV-H5510-00	33 - 2	90170-06010	39 - 7	90209-18070	31 - 24	90480-13018	32 - 15
5AV-F6290-00	29 - 21	5AV-H1940-00	41 - 9	5AV-H5540-10	41 - 1	90170-18165	28 - 34		31 - 29	90480-13398	18 - 11
5AV-F629T-00	29 - 22	5AV-H1960-00	41 - 7	5AV-H5550-10	33 - 1	90175-06013	31 - 12	90215-14321	13 - 22		19 - 4
5AV-F6311-00	29 - 25	5AV-H2110-00	40 - 4	5AV-H5752-00	41 - 14	90176-08026	1 - 12	90249-12008	31 - 11		19 - 9
5AV-F6326-00	29 - 23	5AV-H2115-00	40 - 5	5AV-H5753-00	41 - 15	90179-08168	28 - 23	90280-03017	2 - 9		19 - 24
5AV-F6331-10	29 - 27	5AV-H2116-00	40 - 7	3RW-W0041-02	30 - 5	90179-12659	13 - 11	90338-10846	21 - 27		32 - 6
5AV-F6393-00	29 - 26	5AV-H2131-00	40 - 6	4US-W0045-00	27 - 8	90179-14469	13 - 23	90340-12059	5 - 4		32 - 11
5AV-F7111-00	31 - 1	5AV-H2150-00	40 - 16	4ES-W0047-10	27 - 5	90179-25033	21 - 8	90340-14810	10 - 7	90480-13426	38 - 12
5AV-F7112-00	31 - 2	5AV-H2310-00	40 - 1	51L-W0048-00	27 - 10	90183-04005	21 - 15	90340-32812	10 - 9	90480-15896	21 - 26
5AV-F7114-00	8 - 5	5AV-H2370-00	40 - 3	4TT-W0057-00	27 - 4	90183-05807	19 - 20	90387-053Y7	21 - 24	90480-18476	23 - 5
5AV-F7115-00	31 - 3	5AV-H2501-00	40 - 9	90101-06822	28 - 13		19 - 34	90387-060G7	18 - 9	90480-18881	38 - 9
5AV-F7211-00	31 - 6	5AV-H2530-00	40 - 12	90101-08590	4 - 10	90183-06059	18 - 22		19 - 3	90480-22800	18 - 23
5AV-F7231-00	31 - 9	5AV-H2540-00	41 - 4	90101-08672	28 - 22	90185-10091	26 - 13		19 - 8	90501-02639	12 - 8
5AV-F7235-00	31 - 8	5AV-H2552-00	40 - 10	90105-08024	17 - 2	90185-10154	21 - 22		19 - 23	90501-037J6	13 - 7
5AV-F7311-00	31 - 15	5AV-H2590-10	40 - 13	90105-10036	21 - 21	90185-12046	20 - 6		32 - 3	90501-06022	15 - 3
5AV-F7411-00	31 - 19	5AV-H3310-00	35 - 1	90105-10638	27 - 11		28 - 30		32 - 8	90501-10245	31 - 10

NUMERICAL INDEX  
INDICE NUMERICO

PART NO. CODIGO N°	REF. NO.	PART NO. CODIGO N°	REF. NO.	PART NO. CODIGO N°	REF. NO.	PART NO. CODIGO N°	REF. NO.	PART NO. CODIGO N°	REF. NO.	PART NO. CODIGO N°	REF. NO.
90501-10312	39 - 8	93210-32172	10 - 10	95027-06090	1 - 16	97607-05216	41 - 6				
90501-125E9	16 - 16	93210-41817	28 - 5	95307-06600	28 - 14	97607-05230	6 - 14				
90501-205E8	28 - 45	93210-44704	1 - 10		28 - 37	97607-06210	20 - 8				
90501-217J8	13 - 18	93210-568G8	1 - 18	95307-08700	28 - 47	97607-06216	41 - 8				
90506-18812	28 - 10	93210-63556	1 - 7		31 - 17	97607-06220	6 - 19				
90506-20041	31 - 7	93306-001Y1	14 - 9	95307-10600	20 - 11	97706-40016	35 - 4				
90506-25047	31 - 18	93306-00210	4 - 4	95317-06700	6 - 5		35 - 8				
90506-29054	31 - 4	93306-00308	4 - 3	95607-06100	24 - 6	97706-40625	38 - 8				
90508-263A8	11 - 9	93306-004Y1	28 - 19		25 - 6	97707-40014	35 - 9				
90508-265A1	16 - 9	93306-20229	2 - 15		31 - 26	97707-50014	29 - 13				
90508-295A0	16 - 4	93306-20301	14 - 17		31 - 31	97707-50016	29 - 11				
90560-06201	32 - 14	93306-203X8	14 - 8		39 - 5		36 - 5				
90560-12812	28 - 2	93306-204Y6	14 - 18	95617-08200	17 - 4	98507-06016	1 - 8				
90560-16385	13 - 1	93306-20595	2 - 8	95707-06500	8 - 9		19 - 17				
90560-17328	13 - 21	93306-300Y1	26 - 5		16 - 22		19 - 29				
90560-17384	13 - 12	93306-301Y5	28 - 4		25 - 8		21 - 11				
91317-06010	12 - 9	93306-301Y6	28 - 3		38 - 13	98507-06040	9 - 9				
91317-06012	4 - 6	93310-326M9	2 - 4		41 - 10	98507-06060	9 - 8				
	40 - 11	93340-21210	16 - 11	95707-08500	8 - 7	98507-06080	9 - 7				
91317-06014	33 - 4	93410-20038	14 - 5		23 - 4	98907-05010	21 - 16				
91317-06016	4 - 14	93430-12008	31 - 5	95707-12500	33 - 5	98980-06008	8 - 4				
91317-06025	6 - 4	93440-10153	1 - 3	95804-06010	24 - 11	99009-10400	15 - 8				
	30 - 10	93440-15012	14 - 16		24 - 13	99009-15400	11 - 11				
	33 - 3	93450-14088	2 - 12	95807-06010	41 - 13	99009-19400	11 - 7				
91401-20012	31 - 13	93501-04011	21 - 2	95807-06014	32 - 13	99009-20400	16 - 5				
92017-10016	31 - 36	93503-16003	21 - 5	95807-08016	8 - 10	99236-00080	19 - 37				
92903-12600	20 - 5	93604-10011	16 - 12	95827-06012	25 - 13	99236-00100	19 - 38				
92907-06100	28 - 39	93606-10227	13 - 6	95827-06016	25 - 14	99530-10114	1 - 15				
92907-06600	21 - 18	93608-43157	12 - 2	95827-08016	10 - 6		9 - 6				
	23 - 16	93608-50149	16 - 7		31 - 20		9 - 11				
	31 - 14	93610-10170	12 - 7	95827-08025	24 - 8		10 - 3				
92907-08100	28 - 44	93822-15069	14 - 20	97007-06012	37 - 8						
	29 - 3	94122-17849	26 - 7	97007-06016	17 - 14						
92907-10200	29 - 12	94125-17852	28 - 25		40 - 2						
92907-10600	20 - 15	94222-17830	26 - 8	97007-06020	18 - 8						
	31 - 35	94225-17831	28 - 26		18 - 13						
93101-10142	10 - 20	94322-17827	26 - 9		23 - 3						
93102-12106	16 - 3		28 - 27		32 - 16						
93102-15147	11 - 15	94414-17837	28 - 28	97007-08016	29 - 2						
93102-20366	14 - 19	94414-17888	26 - 10	97017-06012	23 - 15						
93106-20802	26 - 4	94568-39097	28 - 40	97017-06025	11 - 14						
93106-30004	28 - 18	94668-37001	28 - 41	97027-06020	16 - 24						
93109-40047	26 - 17	94700-00846	1 - 13	97027-10020	31 - 34						
93210-06422	16 - 21	95027-06025	10 - 13	97107-06012	21 - 17						
93210-14369	10 - 8		22 - 34	97527-06520	18 - 4						
93210-19522	10 - 19	95027-06040	10 - 4	97601-04012	7 - 5						
93210-22382	41 - 5	95027-06050	10 - 5	97601-04014	7 - 7						
93210-25552	6 - 3	95027-06080	10 - 22	97607-05210	40 - 8						