



YAMAHA

QT50G2

OWNER'S MANUAL

LIT-11626-02-11

3L8-28199-11

SAFETY WARNINGS

1. Traffic regulations vary from state to state. Study the regulations in your state before riding this machine.
2. Never allow children to ride this machine. Check the traffic regulations in your state regarding the minimum age requirements for a driver's license. Abide by all state and local regulations.
3. This machine is a single-seater. It is made for one rider only. Never ride with a passenger. Overloading will adversely affect the machine's stability. Do not load the racks beyond their capacity. The load capacity of the front rack (carrier) is 3 kg (7 lbs). The load capacity of the rear rack (carrier) is 5 kg (11 lbs).
4. This bike is designed for on-road use only. It is not suitable for off-road use.
5. Gasoline is highly flammable.
 - * Always turn off the engine when refuelling.
 - * Take care not to spill any gasoline on the engine or muffler when refuelling.
 - * If any gasoline spills on the engine or muffler, wipe it off immediately.
 - * Never refuel while smoking or in the vicinity of an open flame.
6. Always turn off the engine before leaving the machine unattended.
7. When transporting the machine in another vehicle, be sure it is kept upright and that the fuel petcock is turned off. If it should lean over, gasoline may leak out of the carburetor or fuel tank.

8. The bike should always be on the center stand when you start the engine. Check the throttle grip a few times before starting off. The engine speed should slow down when the throttle is closed.
9. If you should swallow some gasoline or inhale too many gasoline vapors, see your doctor immediately. If any gasoline spills on your skin or clothing, immediately wash with soap and water and change your clothes.
10. Do not run the engine in a closed, unventilated place. Exhaust gases are harmful.

SAFETY RIDING POINTS

1. Give a clear signal in the following instances:

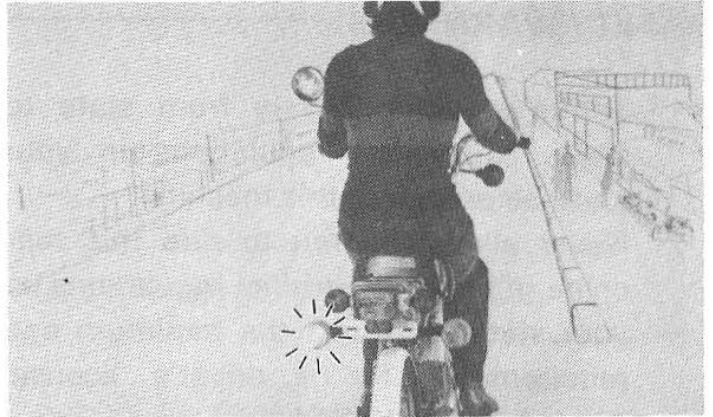

Turning left

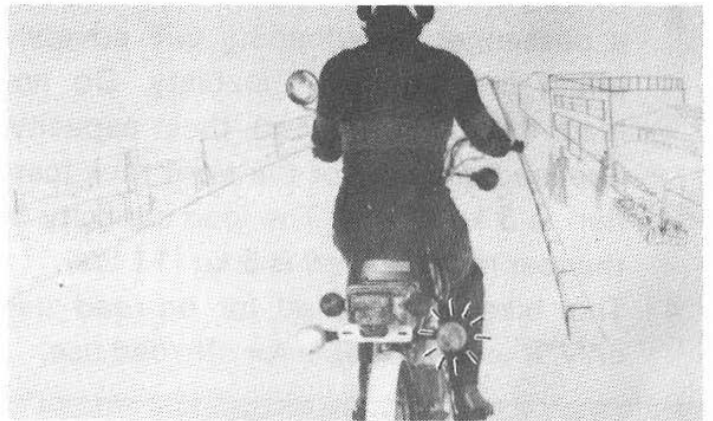

Turning right

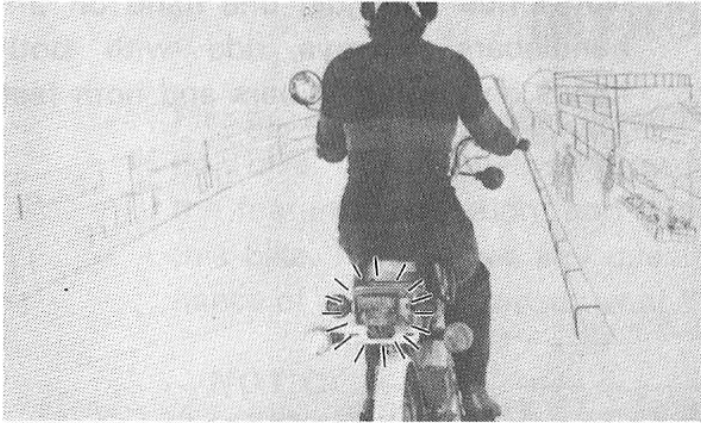

Stopping or slowing down

2. Braking can be extremely difficult on a wet road. Avoid hard braking, the machine could slide. Apply the brakes slowly when stopping on a wet surface.
3. Slow down as you approach a corner or turn. Once you have completed a turn, accelerate slowly.
4. Be careful when passing parked cars. A driver might not see you and open a door in your path.
5. Street car rails, iron plates on road construction sites, and man-hole covers become extremely slippery when wet. Slow down and cross them with caution. Keep the machine upright. It could slide out from under you.
6. The brake lining could get wet when you wash the machine. After washing the machine, check the brakes before riding.
7. Always wear a helmet, gloves, trousers (tapered around the cuff and ankle so they do not flap), and a bright colored jacket.

8. Do not carry too much luggage on the bike. An overloaded machine is unstable. Refer to page 1 for instructions about carrying luggage. Use a strong cord to secure any luggage to the luggage racks. A loose load will affect the stability of the bike and could divert your attention from the road.

9. Never ride with just one hand on the handlebars. Always ride with both hands on the handlebars and both feet on the footrests.

INTRODUCTION

Please read this manual carefully and completely before operating your new bike. This manual will provide you with a good basic understanding of the features, operation, and basic maintenance and inspection items of this bike. If you have any questions regarding the operation or maintenance of your bike, consult your Yamaha dealer.

NOTICE:

Some data in this manual may become outdated due to changes made to this model in the future. If you have any question regarding this manual or your bike, please consult your Yamaha dealer.

NOTICE

Particularly important points are distinguished in this manual by the following notations:

- NOTE:** A NOTE provides key information to make procedures easier or clearer.
- CAUTION:** A CAUTION indicates special procedures that must be followed to avoid damage to the bike.
- WARNING:** A WARNING indicates special procedures that must be followed to avoid injury to a bike operator or person inspecting or repairing the bike.

**QT50G OWNER'S MANUAL
FIRST PRINTING, APRIL, 1979
ALL RIGHTS RESERVED BY
YAMAHA MOTOR COMPANY, LTD., JAPAN
PRINTED IN JAPAN
LIT-11626-01-96**

CONTENTS

MACHINE IDENTIFICATION	8
CONTROL FUNCTIONS.....	9
PRE-OPERATION CHECKS.....	15
RIDING POINTS.....	21
PERIODIC MAINTENANCE	29
CONSUMER INFORMATION	32
WARRANTY INFORMATION	34
SPECIFICATIONS	36
WIRING DIAGRAM.....	40

MACHINE IDENTIFICATION

Frame serial number

The frame serial number is stamped on the front side of the steering head pipe.

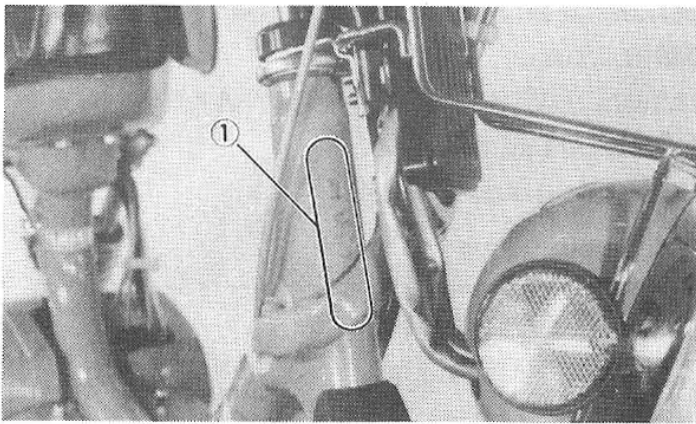

1. Frame serial number

Engine serial number

The engine serial number is stamped into the left side of the engine lower of the crankcase.

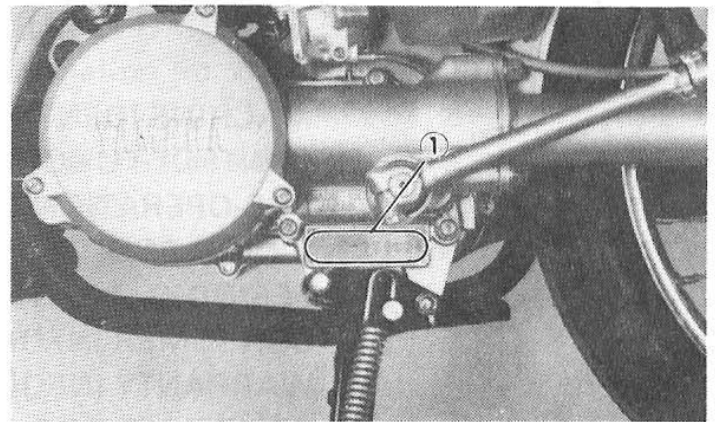

1. Engine serial number

NOTE: _____
The first three digits of these numbers are for model identification; the remaining digits comprise the unit production number.

CONTROL FUNCTIONS

LEFT SIDE

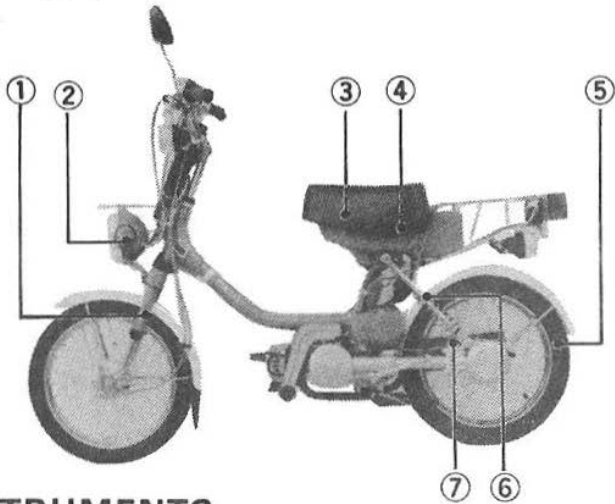

RIGHT SIDE

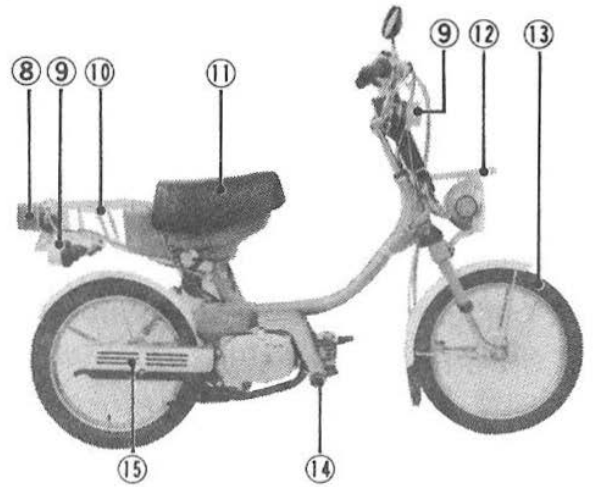

INSTRUMENTS

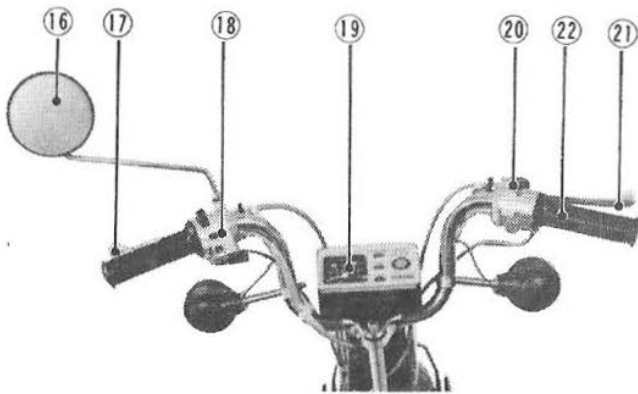

- | | |
|------------------------|--------------------------|
| 1. Front fork | 12. Front rack |
| 2. Headlight | 13. Front wheel |
| 3. Fuel tank | 14. Footrest |
| 4. Oil tank | 15. Muffler |
| 5. Rear wheel | 16. Rear view mirror |
| 6. Rear shock absorber | 17. Rear brake lever |
| 7. Kick crank | 18. Left handle switches |
| 8. Tail/stop light | 19. Speedometer |
| 9. Flasher light | 20. Engine stop switch |
| 10. Rear rack | 21. Front brake lever |
| 11. Seat | 22. Throttle grip |

Main switch

OFF: Engine can not be started. Key can be removed.

✱ : Oil warning light will come on with the key in this position. For details of the oil warning light, refer to the "Oil warning light" on page 11.

ON: Engine can be started with the key in this position. Key cannot be pulled out. Taillight and meter lights always come on automatically. Headlight functions only when the engine is running.

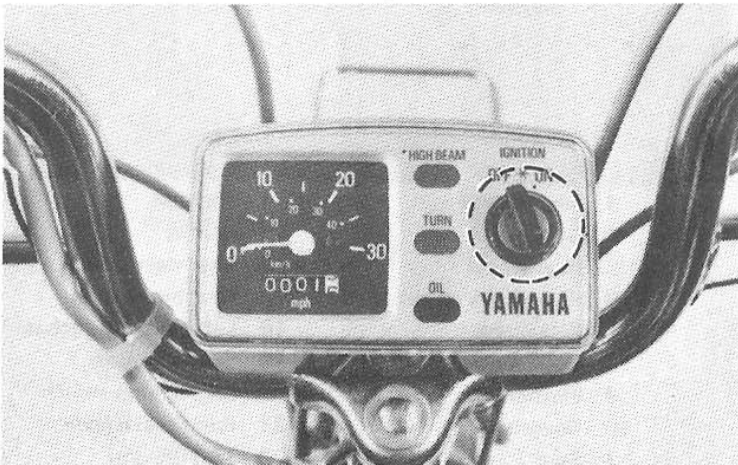

"HORN" switch

Press the button to sound the horn.

"TURN SIGNAL" switch

This is a three way switch: the center position is off. Turn to the "L" position for the left flasher and to the "R" position for the right flasher.

"LIGHTS" switch (dimmer)

Turn to the "HI" position for the high beam and to the "LO" position for the low beam.

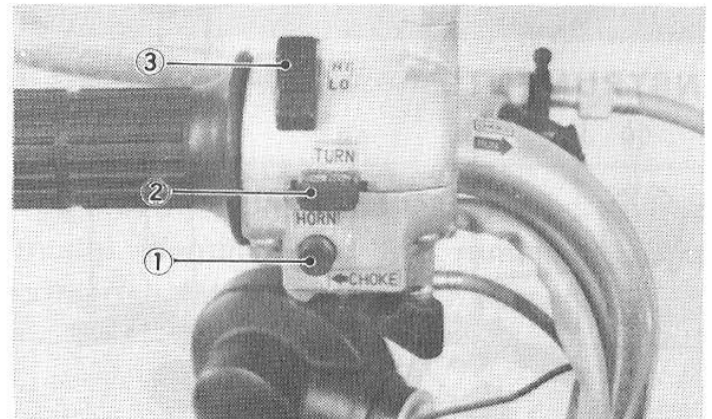

1. "HORN" switch
2. "TURN SIGNAL" switch
3. "LIGHTS" switch (dimmer)

“ENGINE STOP” switch

Make sure that the engine stop switch is turned to “RUN” position. The engine switch has been equipped to ensure safety in an emergency such as when the motorcycle is upset or trouble takes place in the throttle system. The engine will not start or run when the engine stop switch is turned to “OFF”.

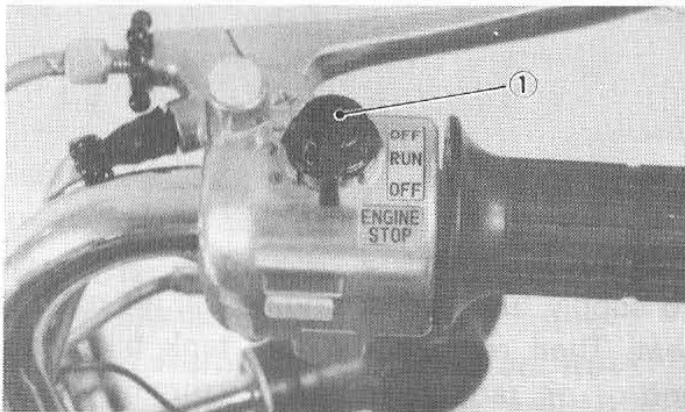

1. “ENGINE STOP” switch

“OIL” warning light (Red)

The light comes on when the main switch position is ~~✖~~ or when there is little oil in the oil tank during operation. If the oil warning light comes on during operation, refill with Yamalube 2-cycle Oil or an equivalent immediately. When the tank is refilled, the oil warning light will go off.

NOTE:

If the oil warning light will not come on while the key is on the “~~✖~~” position, have your Yamaha dealer or other qualified service establishment check it.

CAUTION:

Do not run the bike until you know the bike has enough oil.

“TURN” indicator light (Orange)

This light flashes when either turn indicator is ON.

“HIGH BEAM” indicator light (Blue)

This light comes on when the headlight high beam is used.

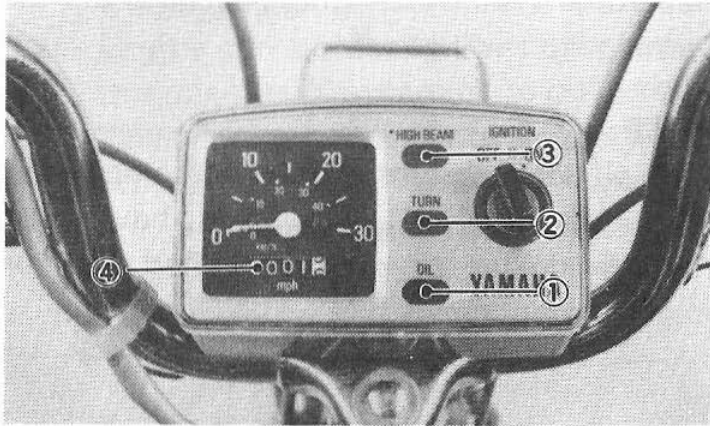

- 1. “OIL” warning light
- 2. “TURN” indicator light
- 3. “HIGH BEAM” indicator light
- 4. Odometer

Starter lever

When starting a cold engine, turn the lever in

the direction of the arrow. After a warm-up run, turn the lever to its home position.

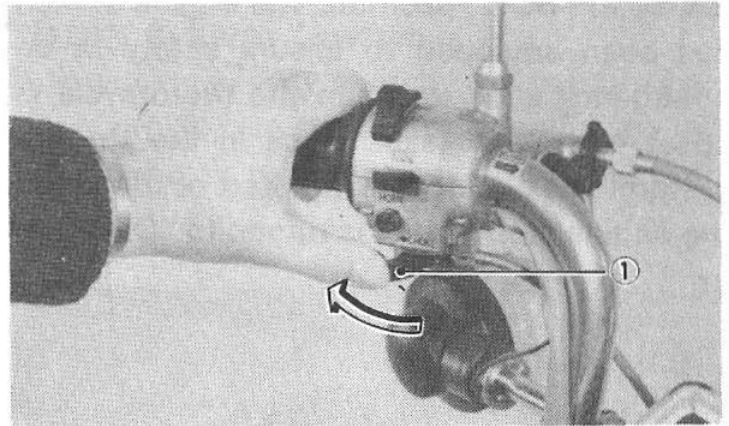

1. Starter lever

Fuel and oil tank

To supply fuel and/or engine oil, lift up the seat. Then remove the fuel tank filler cap and/or oil tank filler cap by turning them counterclockwise.

Fuel tank capacity: 2.3 lit (0.6 U.S. gal)
Oil tank capacity: 0.8 lit (0.8 U.S. qt)

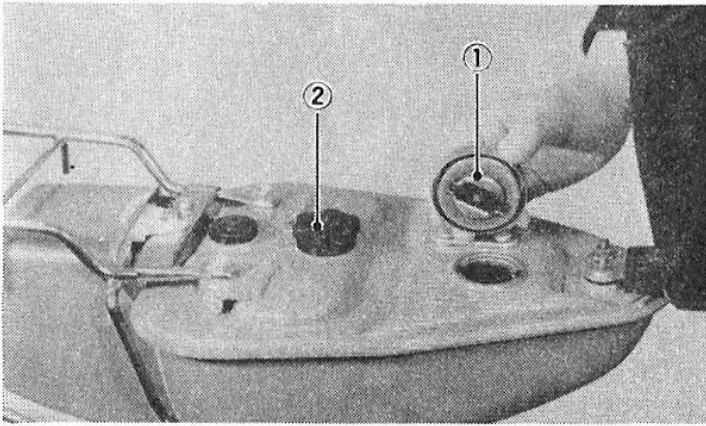

1. Fuel tank cap 2. Oil tank cap

CAUTION:

If the oil tank level lowers during operation, the oil warning light comes on. Refill the tank immediately. If not, engine trouble could occur.

Fuel petcock

The fuel petcock has three positions:

- ON: With the lever in this position, fuel will flow. Normal riding is done with the lever in this position.
- OFF: With the lever in this position fuel will not flow. Always set the lever in this position when the engine is not running.
- RES: If you run out of fuel while riding, turn the lever to this position.

NOTE:

Set the fuel petcock lever to "RES", and have the fuel tank filled as soon as possible. After refilling, be sure to set the lever to "ON". If you start off with the lever placed in "RES", you may continue to ride until you are completely run out of fuel, and you cannot move at all.

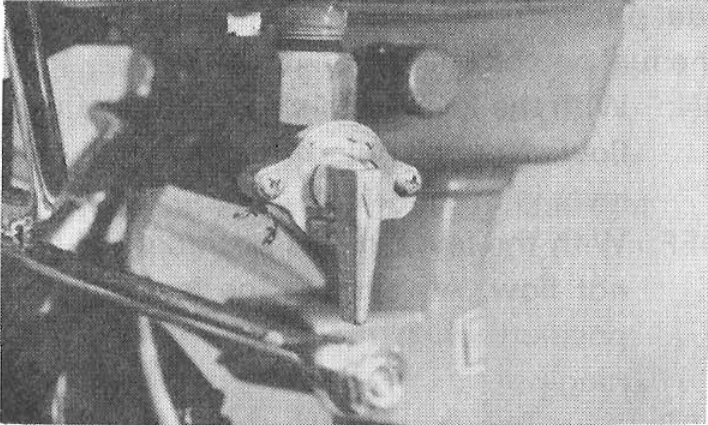

ON position

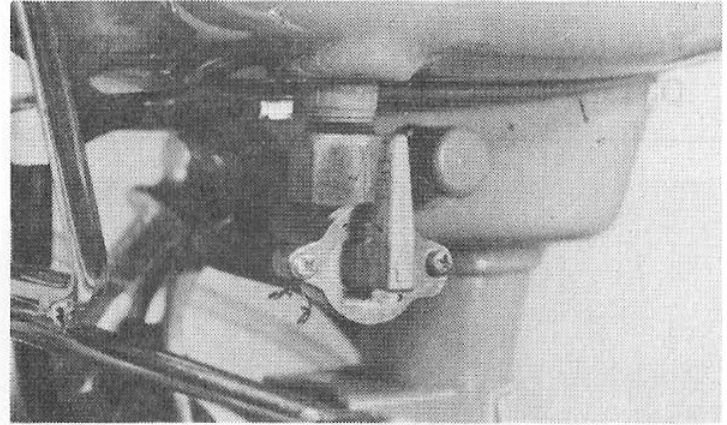

RES position

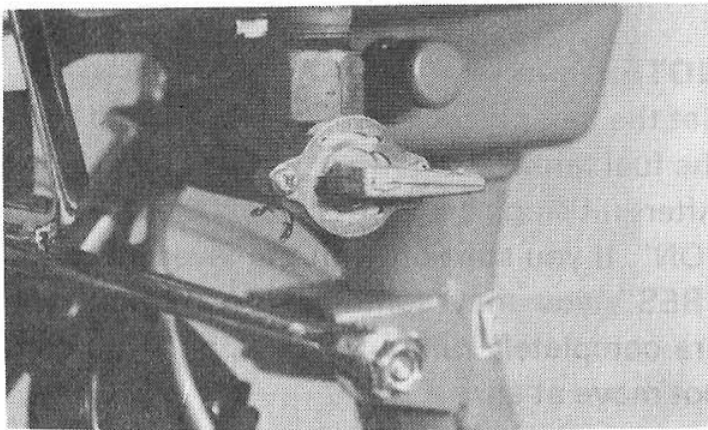

OFF position

Front brake lever

The front brake lever is located on the right handlebar; pull it toward the handlebar to activate the front brake.

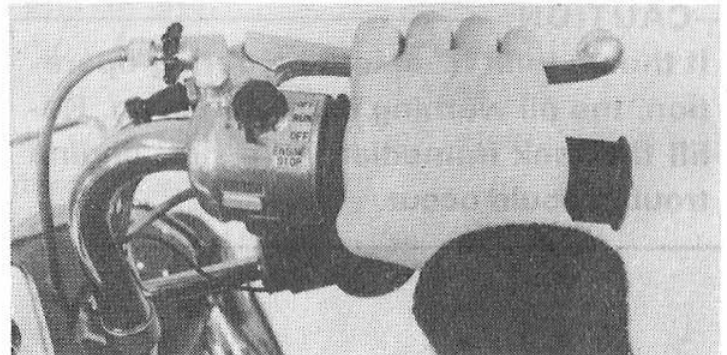

Rear brake lever

The rear brake lever is located on the left handlebar; pull it toward the handlebar to activate the rear brake.

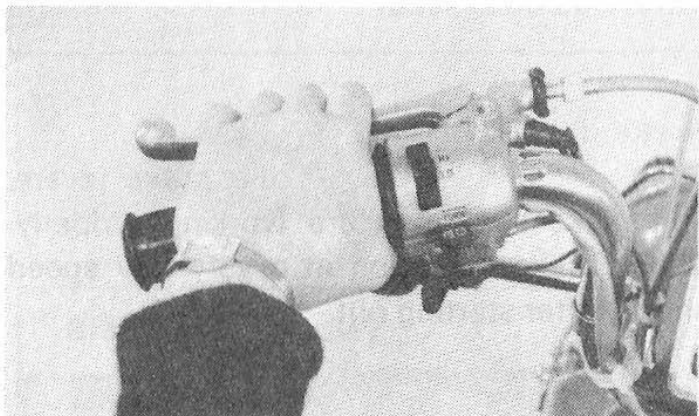

PRE-OPERATION CHECKS

Before riding this vehicle, check the following points:

NOTE: _____

If any of the following items are not functioning properly, do not operate the vehicle until the items have been inspected and repaired. If necessary, ask or call your Yamaha dealer or other qualified service establishment.

Fuel level

Make sure there is sufficient fuel in the tank.

Recommended fuel:

Regular leaded gasoline

Fuel tank capacity: 2.3 lit (0.6 U.S. gal)

WARNING:

Gasoline is inflammable:

- When refueling immediately after operation, take special care not to spill gasoline over the engine or muffler.
- Should you spill gasoline on the engine or muffler, quickly wipe it off before starting the engine.
- When refueling, be sure to stop the engine.
- Never attempt to refuel the bike while smoking or near an open fire.

Engine oil level

Make sure there is sufficient oil in the oil tank.

Recommended oil:

Yamalube 2-cycle Oil or equivalent
Oil tank capacity: 0.8 lit (0.8 U.S. qt)

CAUTION:

If the oil tank level lowers during operation, the oil warning light comes on. Refill the tank immediately. If not, engine trouble could occur.

Brake (front and rear)

Check for correct play in the brake levers, and make sure they are working properly. Check brake operation at a very low speed shortly after starting out.

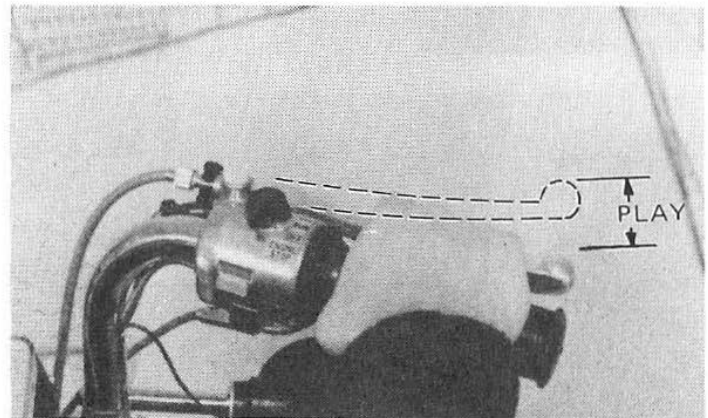

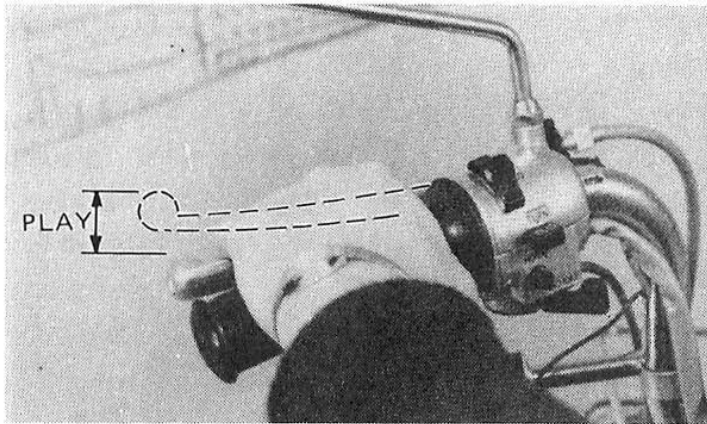

Brake lever free play:
10 ~ 20 mm (0.4 ~ 0.8 in)

Throttle

Turn the throttle grip to see if it operates properly and whether the play is normal. Make certain the throttle snaps closed when released.

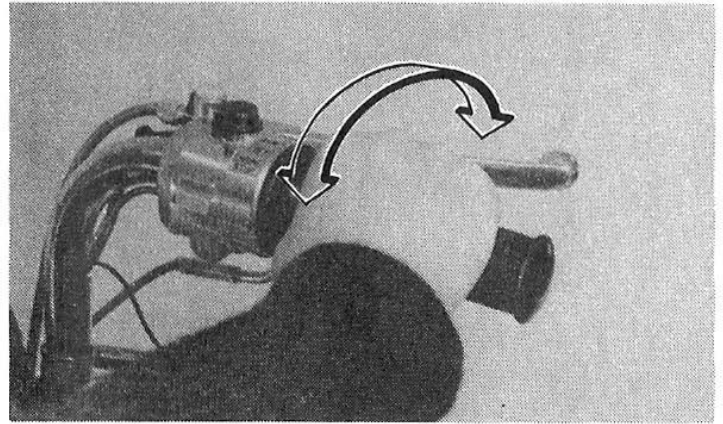

Lights/Signals

Check the headlight, tail/stoplight, turn signal lights and all the indicator lights to make sure they are in working condition.

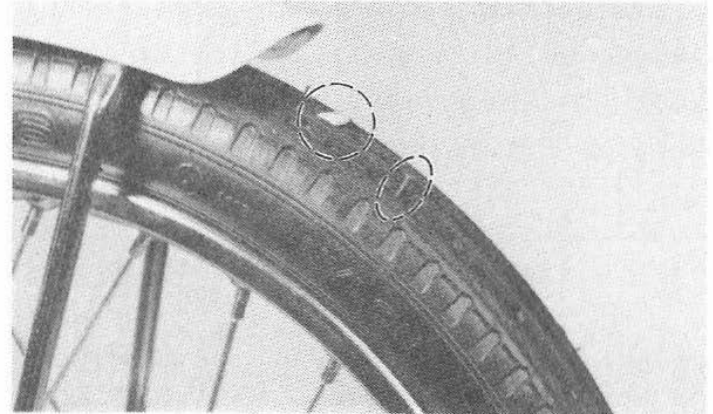
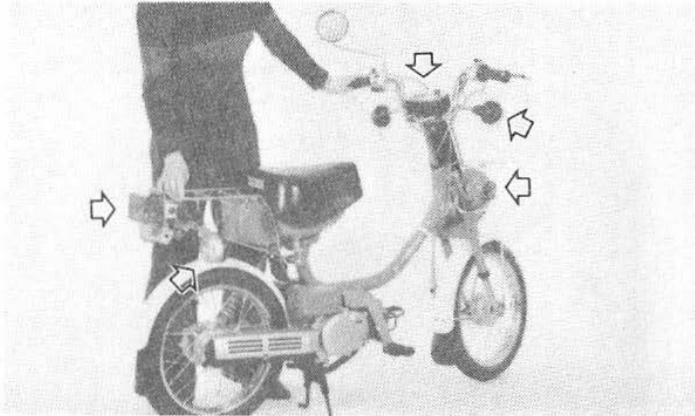

Tires

Check both front and rear tire pressures. Also check for nails, fractions of glass, or stones embedded in tire treads. Check the run-out of each tire rim, and recondition, as necessary. Ask your Yamaha dealer or other qualified service establishment, if required.

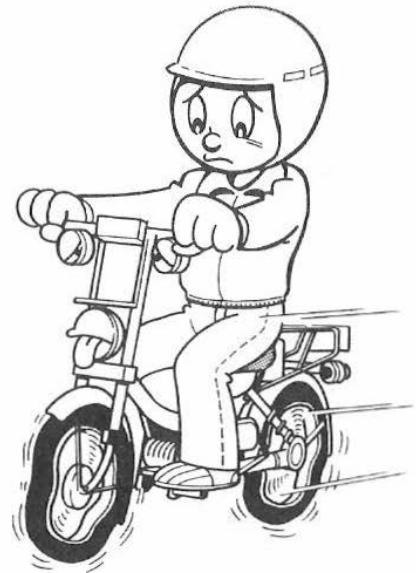

—WARNING:—

Improper tire pressures greatly affect tire life and handling. Check tire pressures prior to each trip and adjust properly, if necessary.

- If tire pressures are too high, shocks from the road will not be damped and will be carried to the frame and handlebars, thus adversely affecting riding comfort. In addition, machine stability will be poor when making a turn.
- If tire pressures are too low, tires will be deformed greatly, thus shortening tire life. When braking the wheels, tires could slip over wheel rims and tire tubes could be broken. When turning the corner or the curve, the bike could easily turn over.

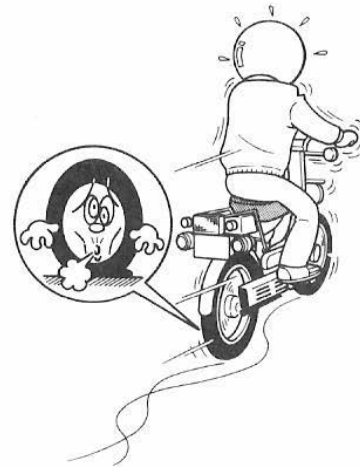

Cold tire pressure:

Front: 1.25 kg/cm² (18 psi)

Rear: 1.75 kg/cm² (24 psi)

Maximum loading limit: 77 kg (170 lb)

If tire treads are excessively worn, the bike tends to slip or skid, on wet roads or even on paved roads covered with dirt.

Minimum depth of groove on tread:

Front: 0.8 mm (0.03 in)

Rear: 0.8 mm (0.03 in)

As a tire is worn heavily, the "SLIP SIGN" will appear on the tread. If so, replace the tire immediately.

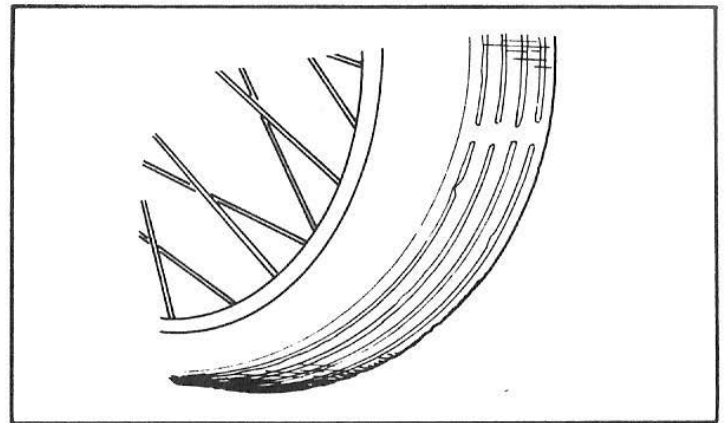
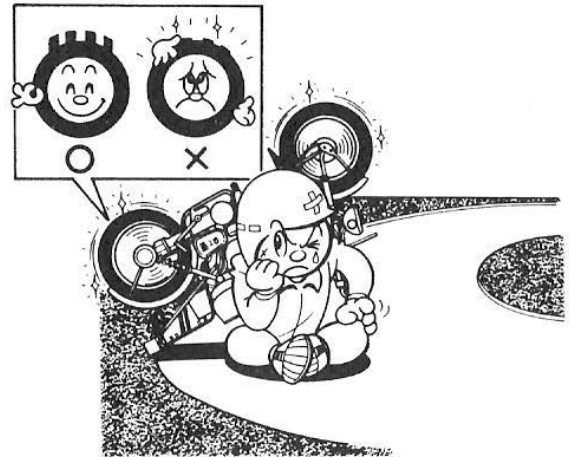

RIDING POINTS

Starting a cold engine

WARNING:

Before starting the engine, be sure to use the mainstand for safety.

1. Turn the fuel petcock lever to the "ON" position.

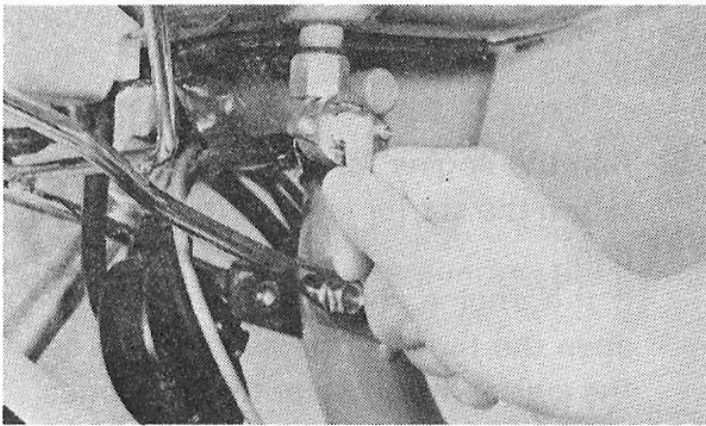

2. Turn the ignition key to the "ON" posi-

tion, and turn the engine stop switch to the "RUN" position.

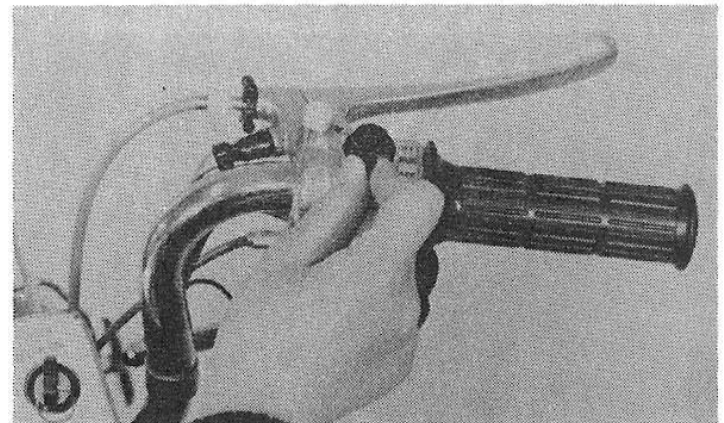
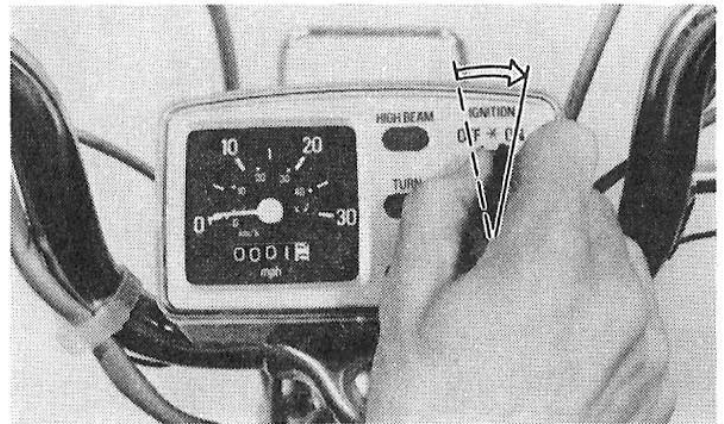

3. Move the starter lever to the left (closed position).

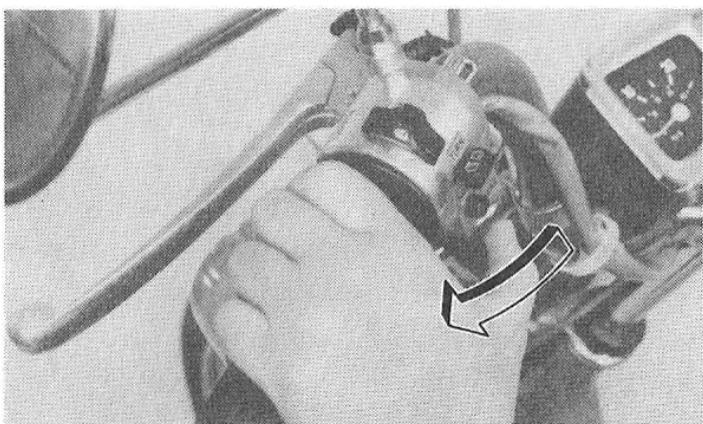

4. Fully close the throttle grip.

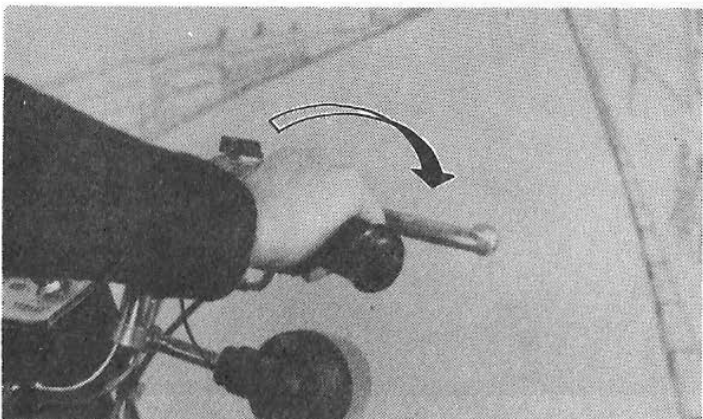

5. Rotate the kick crank, push down lightly with your foot until the gears engage, and then kick briskly downward.

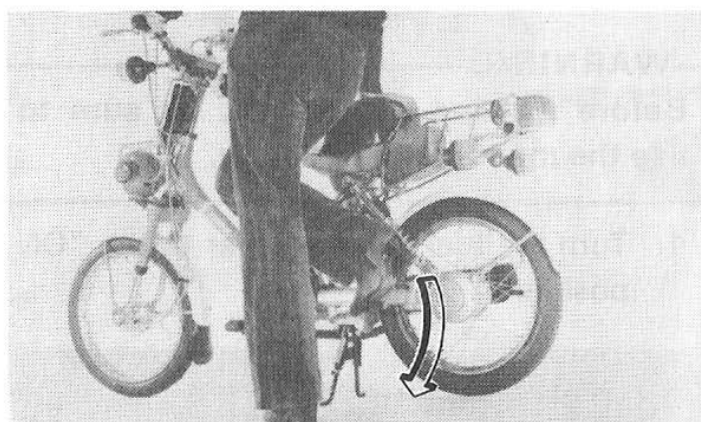

6. Run the engine for 10-30 seconds, and return the starter lever to its home position.

If the engine shows a sign of stalling, open the throttle grip slightly and apply the starter lever two or three seconds.

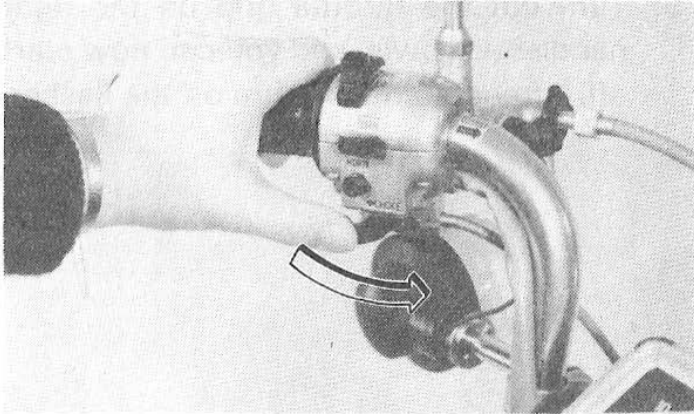

Starting a warm engine

To start a warm engine, the starter lever is not required.

Warming up

To get maximum engine life, always "warm up" the engine about 1-3 minutes before riding the bike. Never accelerate hard with a cold engine.

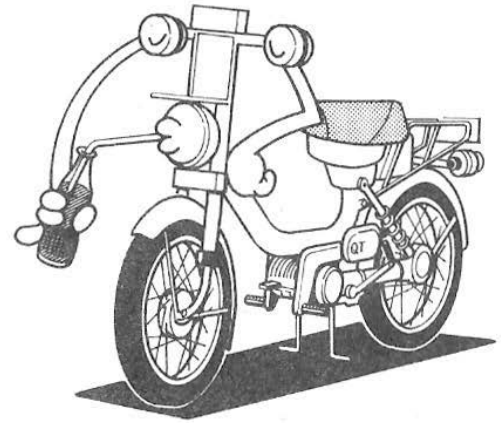

Starting the bike

After warming up the engine;

1. Hold the brake lever (for the rear brake) with your left hand, and push the bike off the center stand while holding the rack (carrier) with your right hand.

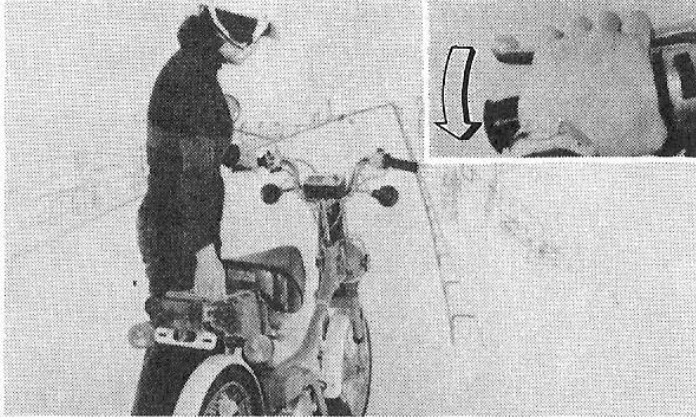

2. Sit astride the seat and check the mirror for its angle. Check the oncoming traffic, and use turn signals before entering traffic.

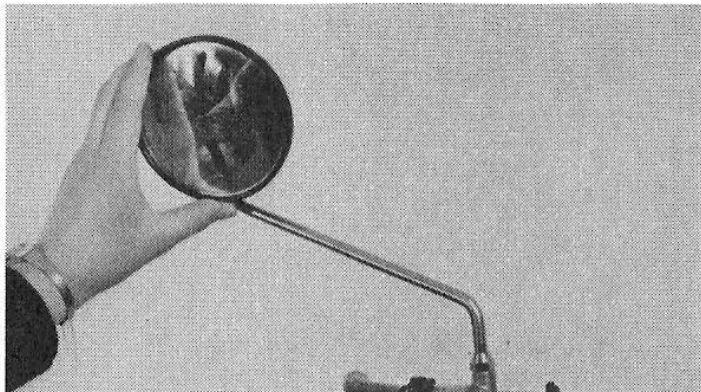

3. Turn out the throttle grip on the right handlebar slowly, and you can now start off. After starting off, turn off the flasher.

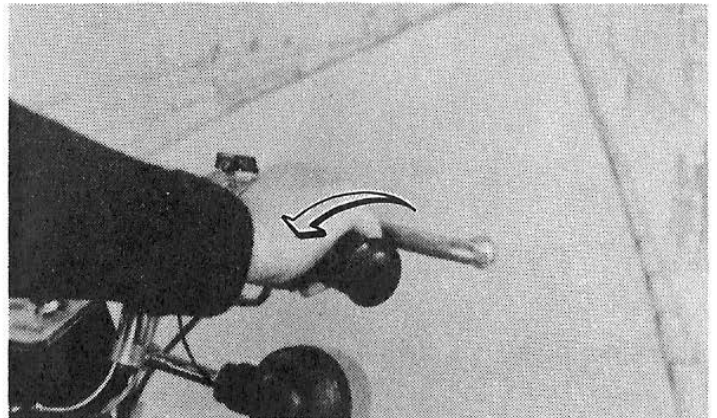

Acceleration

The speed can be adjusted by opening and closing the throttle grip. Turning it out increases the speed, and turning it in decreases the speed.

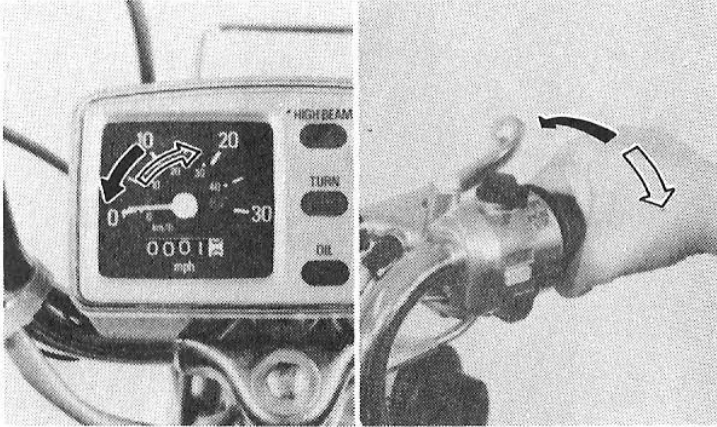

Braking

1. Close the throttle grip.
2. Apply both front and rear brakes simultaneously and with light pressure, and increase the pressure slowly.

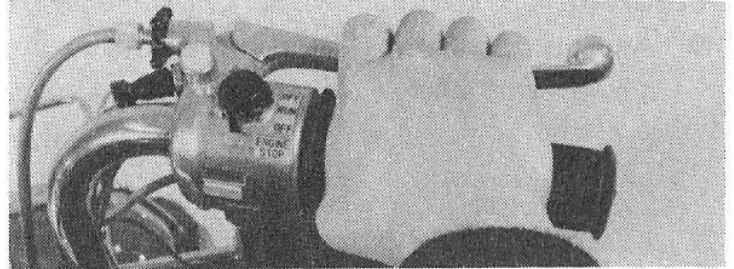
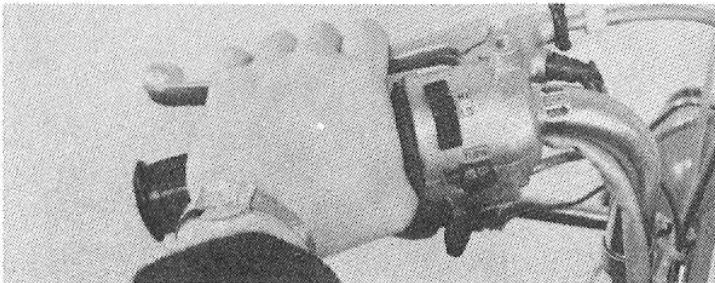

—WARNING:—

- * **Avoid hard or sudden braking. They may cause the bike to skid or overturn.**
- * **Apply the brakes carefully while leaning over to one side. Improper braking could lead to a skid.**
- * **Braking out a wet road will be very difficult.**
- * **Street car rails, metal plates on road construction sites, and man-hole covers become particularly slippery when they get wet. Cross them slowly and cautiously.**
- * **Braking on a hill can be difficult. Proceed slowly when riding downhill.**

Cornering

- As you approach the corner or curve on a wet road, slow down because the bike tends to over turn as a result of slippage or skidding.
- Avoid the quick application of brakes while making a turn. It may cause the bike to overturn.

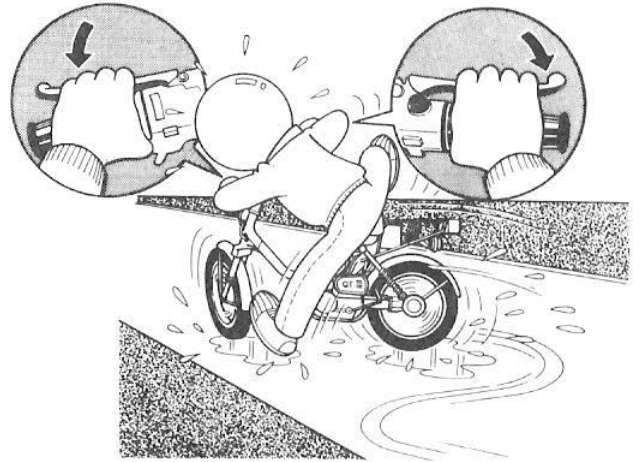
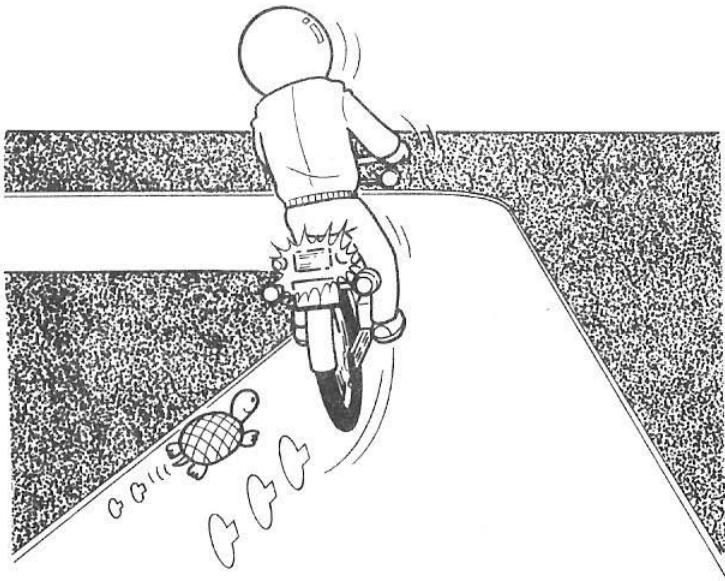

Turning left, turning right

Give a clear signal in the following cases:

Turning left: Apply the left flasher or raise your left hand.

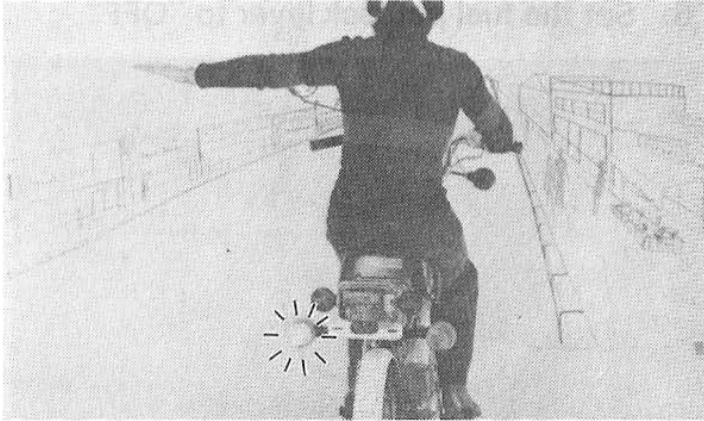

Turning right: Apply the right flasher or raise your left hand.

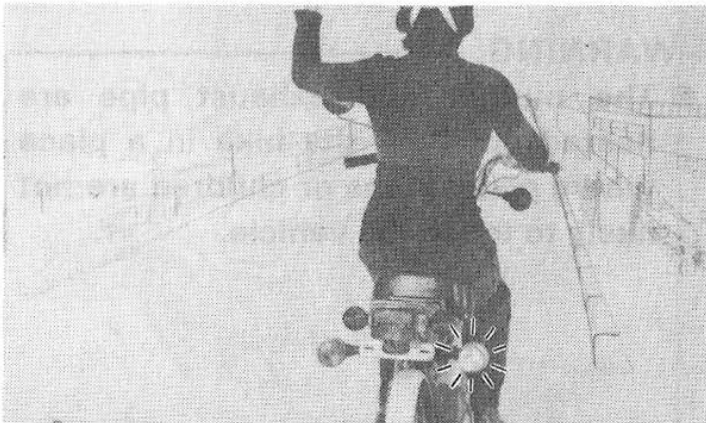

Stopping

1. Turn up the right flasher.

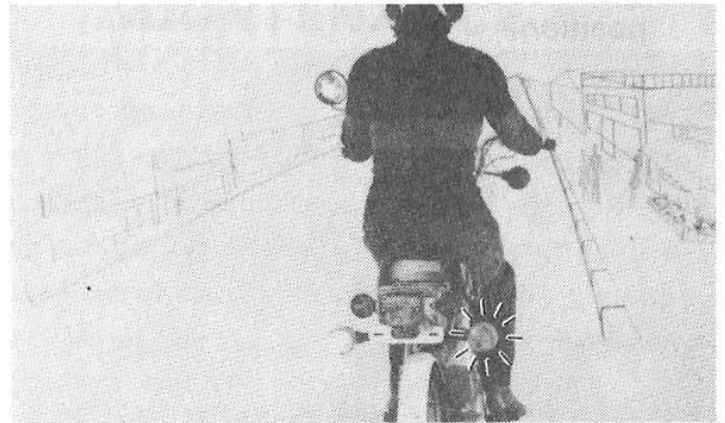

2. Turn the throttle grip in the direction shown in the figure.

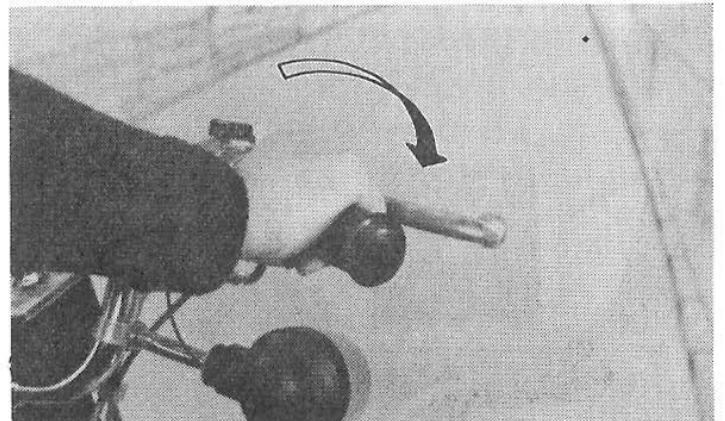

- Using both front and rear brakes, slow down and stop the bike at the desired position.



- Turn the ignition key to "OFF"

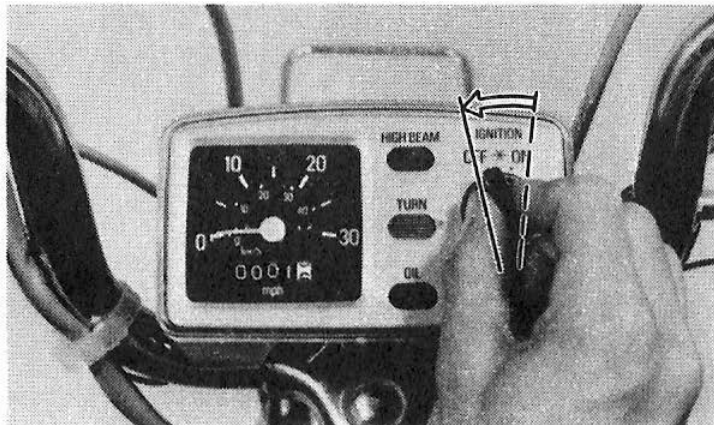

- Set the fuel petcock lever to "OFF".

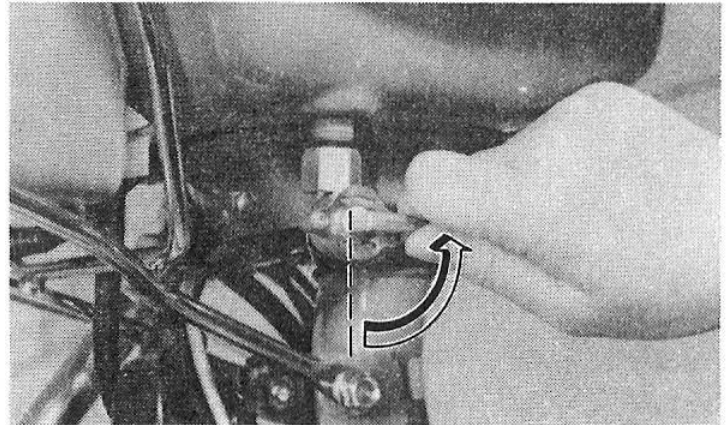

Parking

WARNING:

- The muffler and exhaust pipe are heated up. Park the bike in a place where pedestrians or children are not likely to touch the vehicle.

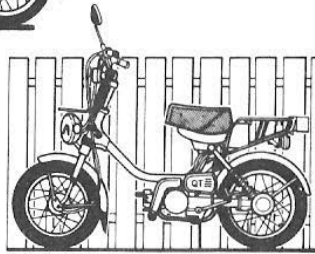
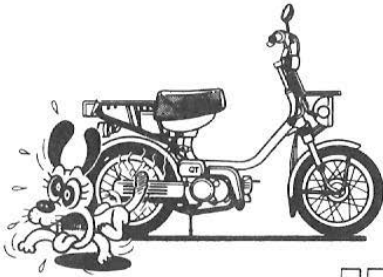

- Do not park the bike on a slop or soft ground; the bike can easily overturn.

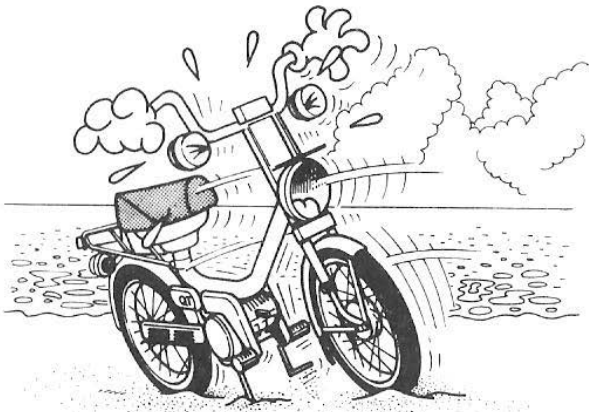

PERIODIC MAINTENANCE

Periodic inspection, adjustment, and lubrication will keep your motorcycle in the safest and most efficient condition possible. Safety is an obligation of the motorcycle owner. The most important points of motorcycle inspection, adjustment, and lubrication are explained on the following pages.

CAUTION:

If the owner is not familiar with motorcycle service, this work should be done by a Yamaha dealer or other qualified service establishment.

PERIODIC MAINTENANCE

Unit: km (mi)

Item	Remarks	Initial			Thereafter every	
		1 Month	3 Months	6 Months	6 Months	1 Year
Cylinder head/Exhaust system	Decarbonize		○	○	○	
Spark plug	Inspect/Cleaning or replace as required	○	○	○	○	
Air filter	Wet type-Must be washed and damped with Yamalube 2-cycle Oil or SAE 20 motor oil		○	○	○	
Carburetor	Check operation/Fittings		○	○	○	
	Clean/Refit/Adjust					○
Autolube pump	Check/Adjust/Air bleeding	○	○	○	○	
* Brake system (complete)	Check/Adjust as required-Repair as required	○	○	○	3 Months	
* Wheels and tires	Check pressure/Wear/Balance/Run out	○	○	○	○	
* Suspension system	Check operation/Repair as required	○	○	○	○	
Fuel petcock	Clean/Flush tank as required	○	○	○	○	
* Battery	Top-up/Check specific gravity and breather pipe	○	○	○	○	
* Lights/Signals	Check operation/Replace as required	○	○	○	○	
* Fittings/Fasteners	Tighten before each trip and/or ...	○	○	○	○	

* Indicates pre-operation check items

LUBRICATION INTERVALS

Unit: km (mi)

Item	Remarks	Type	Initial			Thereafter every	
			1 Month	3 Months	6 Months	6 Months	1 Year
* Transmission oil	Replace/Warm engine before draining	Yamalube 4-cycle Oil or SAE 10W/30 type "SE" motor oil	○	Check	○		○
* Control and meter cables	Apply thoroughly	SAE 10W/30 motor oil		○	○		○
Throttle grip and housing	Apply lightly	Lithium base grease			○	○	
Brake lever	Apply lightly	Lithium base grease		○	○	○	
Brake cam shaft	Apply lightly	Lithium base grease		○	○	○	
Steering bearings	Inspect thoroughly/pack moderately	Medium-weight wheel bearing grease			Check		2 Years
Speedometer gear housing	Inspect thoroughly/pack moderately	Lithium base grease					2 Years
Wheel bearings	Do not over-pack yearly or ...	Medium-weight wheel bearing grease					○
Middle and final gear	Apply lightly	Lithium base wheel bearing grease (EX. SHELL LETHINAX A)					2 Years

* Indicates pre-operation check items.

CONSUMER INFORMATION

STOPPING DISTANCE

This figure indicates braking performance that can be met or exceeded by the vehicles to which it applies, without locking the wheels, under different conditions of loading and with partial failures of the braking system. The information presented represents results obtainable by skilled drivers under controlled road and vehicle conditions, and the information may not be correct under other conditions.

Description of vehicles to which this table applies: Yamaha motorcycle QT50G

A. Fully Operational Service Brake

Load

Light

Maximum

28.2

NOTE: The statement above is required by U.S. Federal law. "Partial failures" of the braking system do not apply to this chart.

0 100 200 300
(Feet)

Stopping distance in feet from 25 mi/h

ACCELERATION AND PASSING ABILITY

This figure indicates passing times and distances that can be met or exceeded by the vehicles to which it applies, in the situations diagrammed below.

The low-speed pass assumes an initial speed of 20 mi/h. and a limiting speed of 35 mi/h. The high-speed pass assumes an initial speed of 50 mi/h. and a limiting speed of 80 mi/h.

NOTICE: The information presented represents results obtainable by skilled drivers under controlled road and vehicle conditions, and the information may not be correct under other conditions.

Description of vehicles to which this table applies: Yamaha motorcycle QT50G

Summary table

Low-speed pass	618.8 feet: 16.36 seconds
High-speed pass.....	Not capable

LOW-SPEED

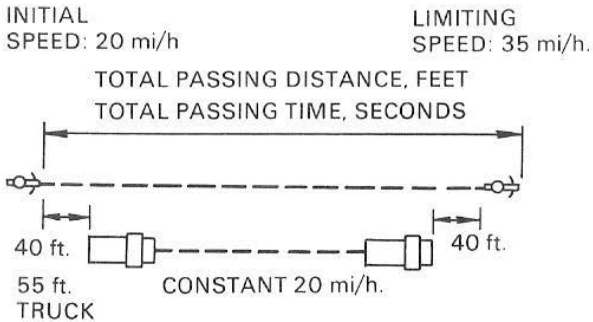

HIGH-SPEED

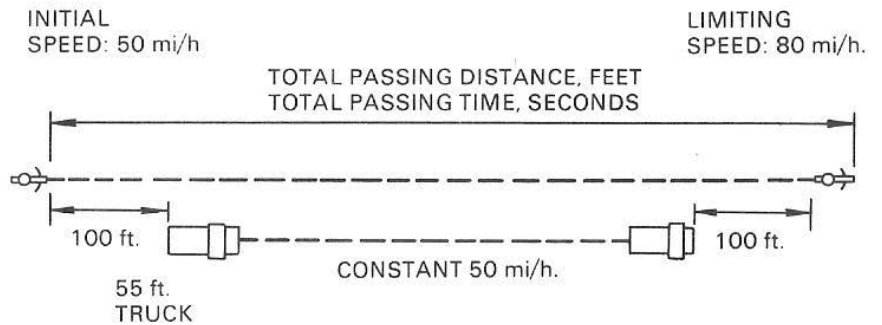

SPECIFICATIONS

Model	QT50G
Dimension:	
Overall length	1,550 mm (61.0 in)
Overall width	670 mm (26.4 in)
Wheelbase	1,050 mm (41.3 in)
Minimum road clearance	110 mm (4.3 in)
Weight:	
Net	43 kg (95 lb)
Minimum turning radius:	1,500 mm (59.1 in)
Climbing capacity	9.6°
Engine:	
Type	2-stroke, gasoline
Cylinder	Single, forward inclined
Displacement	49 cc (3.0 cu.in)
Bore and stroke	40.0 x 39.2 mm (1.57 x 1.54 in)
Compression ratio	6.0 : 1
Starting system	Kick
Ignition system	C.D.I.
Gasoline tank capacity	2.3 lit (0.6 US.gal)
Oil tank capacity	0.8 lit (0.8 US.qt)
Lubrication system	Separate lubrication (Yamaha Autolube)

Model	QT50G
Battery capacity	6V, 4AH
Generator system	Flywheel magneto
Spark plug	BP4HS,
Carburetor	VM12SC
Air cleaner	Oiled foam rubber
Transmission:	
Primary reduction system	Gear
Primary reduction ratio	63/33 (1.909)
Secondary reduction system	Gear (Shaft drive)
Secondary reduction ratio	19/15 x 57/10 (7.220)
Clutch type	Wet, centrifugal automatic
Steering: Caster	25°
Trail	75 mm (2.95 in)
Tire size: Front	2.00-14-4PR
Rear	2.25-14-4PR
Suspension: Front	Telescopic fork
Rear	Unit swing

Model	QT50G
Shock absorber: Front Rear	Coil spring Coil spring oil damper
Frame:	Steel tube underbone
Electrical:	
Headlight	6V, 20W/20W
Tail/Stop light	6V, 3W/17W
Flasher light	6V, 17W
Flasher pilot light	6V, 3W
High beam indicator light	6V, 3W
Oil warning light	6V, 3W
Meter light	6V, 3W

WIRING DIAGRAM

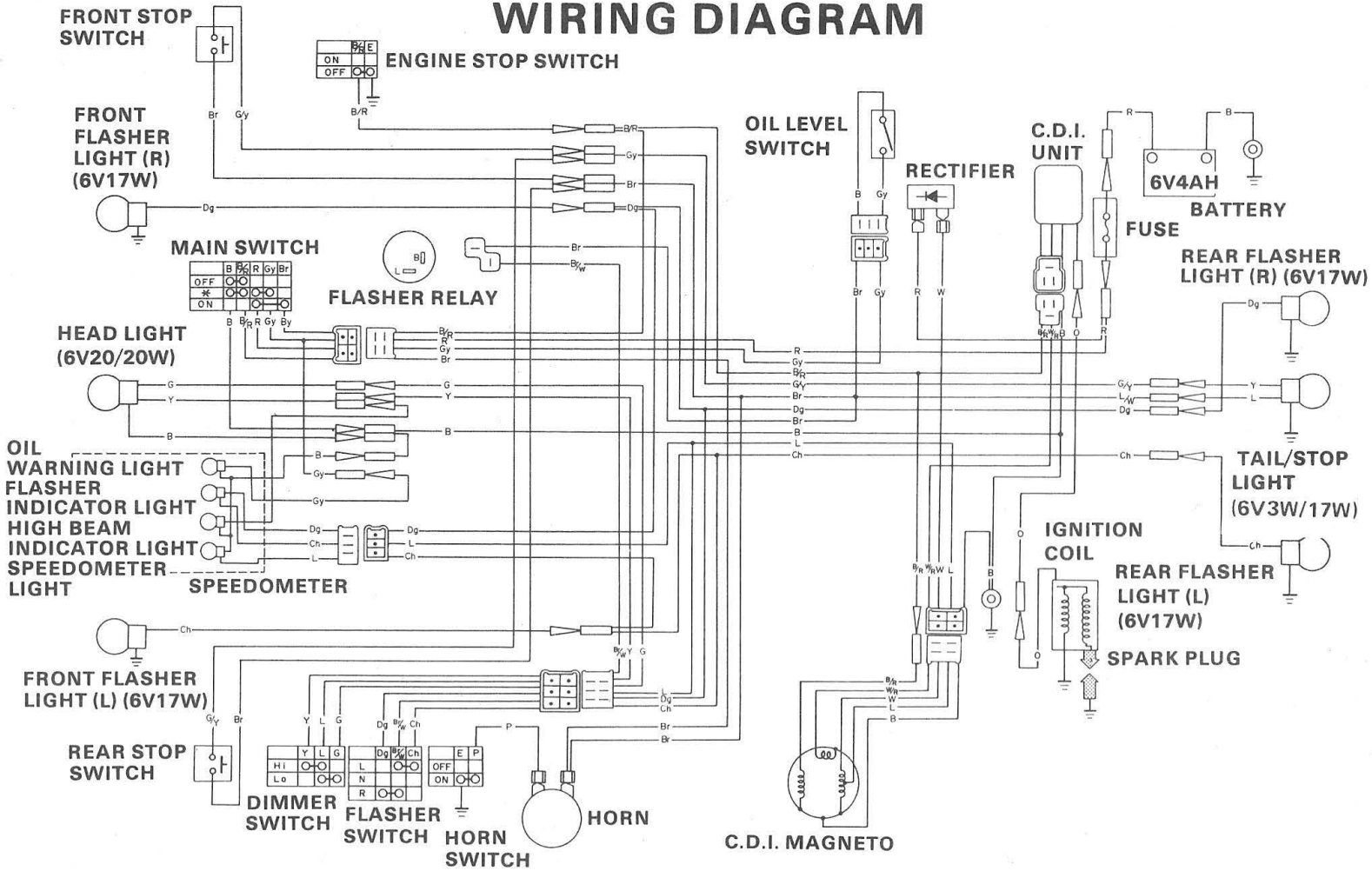

COLOR CODE

R.....	Red	Dg	Dark green
L.....	Blue	Ch.....	Dark brown
B.....	Black	Gy.....	Gray
P.....	Pink	Br.....	Brown
Y.....	Yellow	G/Y.....	Green/Yellow
G.....	Green	B/R.....	Black/Red
O.....	Orange	W/R	White/Red
W.....	White	Br/W	Brown/White
		L/W.....	Blue/White