



SERVICE STATION MANUAL

664779-664786 (IT-EN-FR-DE-ES-PT-NL-EL)



Vespa S 125



SERVICE STATION MANUAL

Vespa S 125

The descriptions and illustrations given in this publication are not binding. While the basic specifications as described and illustrated in this manual remain unchanged, PIAGGIO-GILERA reserves the right, at any time and without being required to update this publication beforehand, to make any changes to components, parts or accessories, which it considers necessary to improve the product or which are required for manufacturing or construction reasons.

Not all versions/models shown in this publication are available in all countries. The availability of single versions should be checked at the official Piaggio sales network.

"© Copyright 2007 - PIAGGIO & C. S.p.A. Pontedera. All rights reserved. Reproduction of this publication in whole or in part is prohibited."

PIAGGIO & C. S.p.A. - After-Sales

V.le Rinaldo Piaggio, 23 - 56025 PONTEDERA (Pi)

SERVICE STATION MANUAL

Vespa S 125

This service station manual has been drawn up by Piaggio & C. Spa to be used by the workshops of Piaggio-Gilera dealers. It is assumed that the user of this manual for maintaining and repairing Piaggio vehicles has a basic knowledge of mechanical principles and vehicle repair technique procedures. Any significant changes to vehicle characteristics or to specific repair operations will be communicated by updates to this manual. Nevertheless, no mounting work can be satisfactory if the necessary equipment and tools are unavailable. It is therefore advisable to read the sections of this manual concerning special tools, along with the special tool catalogue.

N.B. Provides key information to make the procedure easier to understand and carry out.

CAUTION Refers to specific procedures to carry out for preventing damages to the vehicle.

WARNING Refers to specific procedures to carry out to prevent injuries to the repairer.



Personal safety Failure to completely observe these instructions will result in serious risk of personal injury.



Safeguarding the environment Sections marked with this symbol indicate the correct use of the vehicle to prevent damaging the environment.



Vehicle intactness The incomplete or non-observance of these regulations leads to the risk of serious damage to the vehicle and sometimes even the invalidity of the guarantee.



INDEX OF TOPICS

CHARACTERISTICS

CHAR

TOOLING

TOOL

MAINTENANCE

MAIN

TROUBLESHOOTING

TROUBL

ELECTRICAL SYSTEM

ELE SYS

ENGINE FROM VEHICLE

ENG VE

ENGINE

ENG

SUSPENSIONS

SUSP

BRAKING SYSTEM

BRAK SYS

CHASSIS

CHAS

PRE-DELIVERY

PRE DE

TIME

TIME

INDEX OF TOPICS

CHARACTERISTICS

CHAR

Rules

This section describes general safety rules for any maintenance operations performed on the vehicle.

Safety rules

- If work can only be done on the vehicle with the engine running, make sure that the premises are well-ventilated, using special extractors if necessary; never let the engine run in an enclosed area. Exhaust fumes are toxic.
 - The battery electrolyte contains sulphuric acid. Protect your eyes, clothes and skin. Sulphuric acid is highly corrosive; in the event of contact with your eyes or skin, rinse thoroughly with abundant water and seek immediate medical attention.
 - The battery produces hydrogen, a gas that can be highly explosive. Do not smoke and avoid sparks or flames near the battery, especially when charging it.
 - Fuel is highly flammable and it can be explosive given some conditions. Do not smoke in the working area, and avoid naked flames or sparks.
 - Clean the brake pads in a well-ventilated area, directing the jet of compressed air in such a way that you do not breathe in the dust produced by the wear of the friction material. Even though the latter contains no asbestos, inhaling dust is harmful.
-

Maintenance rules

- Use original PIAGGIO spare parts and lubricants recommended by the Manufacturer. Non-original or non-conforming spares may damage the vehicle.
 - Use only the appropriate tools designed for this vehicle.
 - Always use new gaskets, sealing rings and split pins upon refitting.
 - After removal, clean the components using non-flammable or low flash-point solvents. Lubricate all the work surfaces, except tapered couplings, before refitting these parts.
 - After refitting, make sure that all the components have been installed correctly and work properly.
 - For removal, overhaul and refit operations use only tools with metric measures. Metric bolts, nuts and screws are not interchangeable with coupling members with English sizes. Using unsuitable coupling members and tools may damage the scooter.
 - When carrying out maintenance operations on the vehicle that involve the electrical system, make sure the electric connections have been made properly, particularly the ground and battery connections.
-

Vehicle identification

Chassis prefix: ZAPM44302

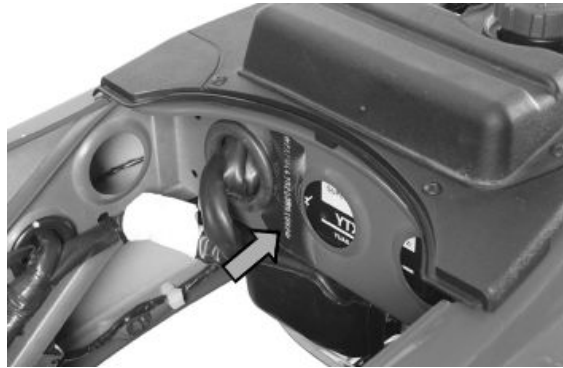

Engine prefix: M444M



Dimensions and mass

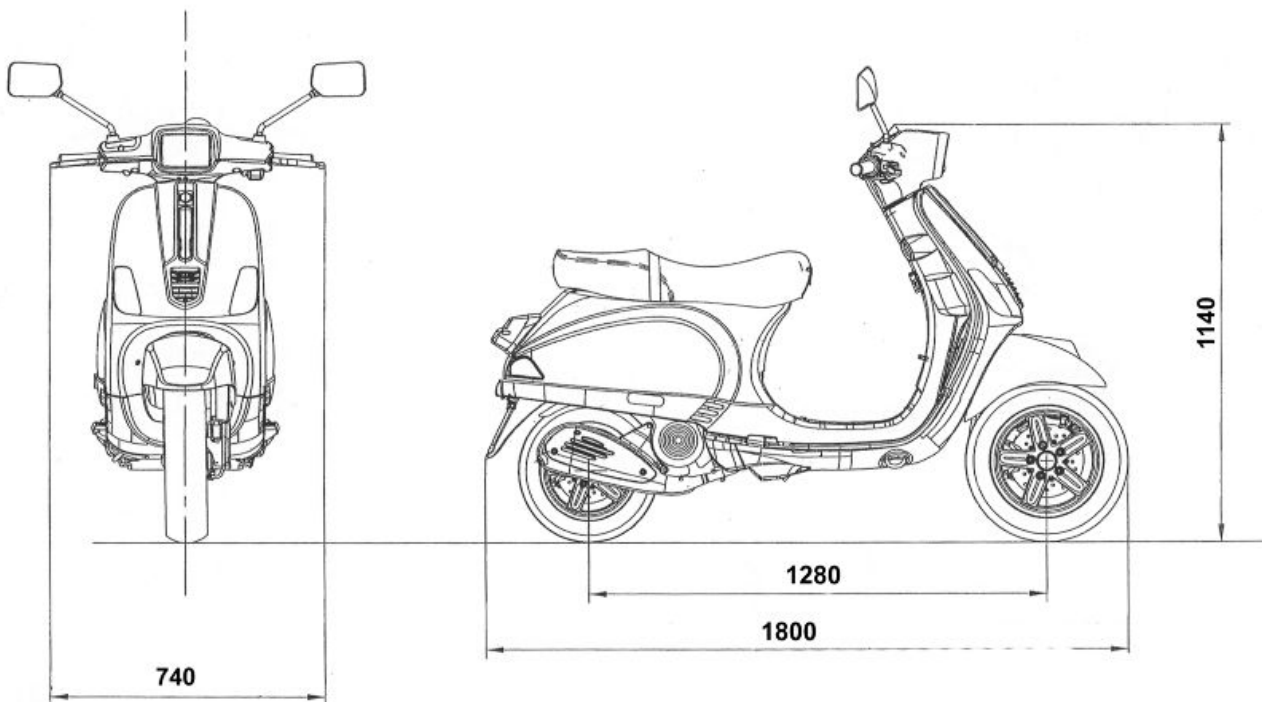

WEIGHTS AND DIMENSIONS

Specification	Desc./Quantity
Kerb weight	114 ± 5 kg
Maximum weight allowed	300 kg
Maximum height	1140 mm
Width	740 mm
Wheelbase	1280 mm
Length	1800 mm

Engine**ENGINE**

Specification	Desc./Quantity
Type	Single-cylinder, 4-stroke
Cubic capacity	124 cm ³
Bore x stroke	57.0 x 48.6 mm
Compression ratio	10.6 ± 0.5 : 1
Engine idle speed	1650 ± 100 rpm
Timing system	2 valves, single overhead camshaft, chain driven.
Valve clearance	Inlet: 0.10 mm Outlet: 0.15 mm
MAX. power	7.65 kW at 8,250 rpm
MAX. torque	9.6 Nm at 7,250 rpm
Lubrication	Engine lubrication with lobe pump (inside crankcase) controlled by a chain with double filter: mesh and paper.
Lubrication pressure	4 bar
Minimum lubrication pressure (100° C)	0.8 bar
Fuel supply	Carburettor KEHIN CVK 26 and electrical fuel pump.
Cooling	Forced-air circulation cooling.
Fuel	Unleaded petrol (95 RON)
Exhaust muffler	absorption-type exhaust muffler with catalytic converter.
Emission regulations	EURO 3

Transmission**TRANSMISSION**

Specification	Desc./Quantity
Transmission	Automatic expandable pulley variator with torque server, V-belt, self-ventilating dry automatic centrifugal clutch and transmission housing with forced-circulation air cooling.
Final reduction	Gear reduction unit in oil bath.

Capacities**CAPACITY**

Specification	Desc./Quantity
Engine oil	1.10 l
Transmission oil	100 cm ³
Fuel tank (reserve)	~ 8.5 l (2 l)

Electrical system**ELECTRICAL SYSTEM**

Specification	Desc./Quantity
Start-up	Electrical and kick start

Specification	Desc./Quantity
Ignition	Capacitive discharge ignition, with variable advance and separate HV coil.
Ignition advance	Three-dimensional map managed by control unit
Spark plug	CHAMPION RG 6 YC
Alternative spark plug	NGK CR7EB
Battery	Sealed, 12 V / 10 Ah

Frame and suspensions

FRAME AND SUSPENSIONS

Specification	Desc./Quantity
Frame	Stamped plate body with welded structural reinforcements.
FRONT SUSPENSION	Single arm with helicoidal spring and single double-acting hydraulic shock absorber.
Front suspension travel	70.3 mm
Rear suspension	Double-acting shock absorber, adjustable to four positions at preloading.
Rear suspension travel	83 mm

Brakes

BRAKES

Specification	Desc./Quantity
Front brake	Ø 200 mm disc brake with hydraulic control activated by handlebar right-side lever.
Rear brake	Ø 110 mm drum brake with mechanical control activated by the handlebar left-side lever.

Wheels and tyres

WHEELS AND TYRES

Specification	Desc./Quantity
Wheel rim type	Light alloy rims.
Front rim	11" x 2.50
Rear rim	10" x 3.00
Front tyre	Tubeless, 110/70 - 11" 45L
Rear tyre	Tubeless, 120/70 - 10" 54L
Front tyre pressure (with passenger)	1.6 bar (1.6 bar)
Rear tyre pressure (with passenger)	2.0 bar (2.3 bar)

Secondary air

In order to reduce polluting emissions, the vehicle is furnished with a catalytic converter in the muffler.

To favour the catalytic process, an extra amount of oxygen is added to the exhaust through a secondary air system (SAS).

This system allows more oxygen to be added to the unburned gases before they reach the con-

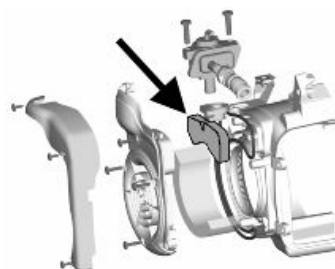

verter, thus improving the action of the catalytic converter.

The air enters the exhaust duct from the head, and is purified by a black filter.

The system is fitted with a control valve that disables operation while decelerating to avoid unwanted noise.

To ensure the best functioning of the SAS system clean the filter as indicated in the scheduled maintenance table.

The filter sponge should be cleaned with water and mild soap, then it should be dried with a cloth and slight blows of compressed air.

Carburettor

125cc Version

Kehin

CARBURETTOR SETTING

Specification	Desc./Quantity
Type	CVEK26
Throttle valve diameter	Ø 26.5
Diffuser diameter	Ø 26.4
Setting stamping	270C
Maximum jet	82
Maximum air jet (on the body)	85
Tapered pin stamping	NJHA
Throttle valve spring	130 ÷ 180 gr.
Minimum jet	42
Idle air jet (on the body)	150
Idle mixture adjustment screw initial opening	2 ½
Starter jet	35
Starter air jet (on the body)	Ø 1.5
Starter pin travel	10 mm (at 24°)
Starter resistance	20 Ohm (at 24°)

Tightening Torques

LUBRICATION

Name	Torque in Nm
Hub oil drainage cap	15 ÷ 17
Engine oil drainage plug	24 ÷ 30
Oil filter	4 ÷ 6
Oil pump cover screws	5 - 6
Oil pump screws	5 - 6
Pump control pulley screw	10 ÷ 14

Name	Torque in Nm
Chain cover screws	4 ÷ 6
Oil sump screws	10 ÷ 14
Minimum oil pressure sensor	12 ÷ 14
Blow-by recovery duct fixing screws	3 - 4

HEAD AND CYLINDER

Name	Torque in Nm
Ignition spark plug	12 ÷ 14
Head cover screws	11 ÷ 13
Nuts fixing head to cylinder (*)	10 + 90° + 90° [further tighten by 90° with new stud bolts].
Head fixing screws (external)	11 ÷ 13
Starter ground screw	7 ÷ 8.5
Flywheel cover screw	1 ÷ 2
Flywheel air manifold screw	3 ÷ 4
Pressure reducer counterweight retainer	7 ÷ 8.5
Camshaft pulley screw	12 ÷ 14
Timing chain tensioner slider screw	10 ÷ 14
Starter ground support screw	11 ÷ 15
Tensioner screws	11 ÷ 13
Timing chain tensioner central screw	5 - 6
Camshaft retention plate screw	5 - 6
Nut fixing muffler to cylinder head	16 ÷ 18
Head intake manifold screw	11 ÷ 13

(*) - Lubricate the retainer threads and tighten to the prescribed torque in a criss-cross sequence.

TRANSMISSION

Name	Torque in Nm
Drive pulley nut	75 ÷ 83
Transmission cover screw	11 ÷ 13
Driven pulley shaft nut	54 ÷ 60
Rear hub cap screw	24 ÷ 27
Clutch unit nut on driven pulley	45 ÷ 50

FLYWHEEL

Name	Torque in Nm
Flywheel fan screws	3 ÷ 4
Stator assembly screws (°)	3 ÷ 4
Flywheel nut	52 ÷ 58
Pick-up screw	3 ÷ 4

(°) Apply LOCTITE 243 threadlock

CRANKCASE AND CRANKSHAFT

Name	Torque in Nm
Internal engine crankcase bulkhead (transmission-side half shaft) screws	4 ÷ 6
Oil filter on crankcase fitting	27 ÷ 33
Rear brake cam tightening screw	11 ÷ 13
Engine-crankcase coupling screws	11 ÷ 13
Pre-filter cap	24 ÷ 30
Starter motor fixing screw	11 ÷ 13
Muffler to crankcase fixing screws	24 ÷ 27
Engine oil drainage cap	24 ÷ 30

STEERING ASSEMBLY

Name	Torque in Nm
Steering upper ring nut	35 ÷ 40
Steering lower ring nut	8 ÷ 10
Handlebar lock nut	45 ÷ 50

FRAME ASSEMBLY

Name	Torque in Nm
Swinging arm pin - frame	44 ÷ 52
Engine-swinging arm bolt	33 ÷ 41
Stand bolt	32 ÷ 40
Swinging arm silent-block containment bolt	33 ÷ 41

FRONT BRAKE

Name	Torque in Nm
Brake fluid pump-hose fitting	8 ÷ 12
Brake fluid pipe-calliper fitting	20 ÷ 25
Screw tightening calliper to the support	20 ÷ 25
Brake disc screws	8 ÷ 10
Circuit bleed calliper fitting	20 ÷ 25
Handlebar pump	7 ÷ 10

FRONT SUSPENSION

Name	Torque in Nm
shock absorber upper clamp	20 ÷ 30
Lower shock absorber clamp	20 ÷ 27
Front wheel axle nut	75 ÷ 90
Shock absorber upper bracket bolts	20 ÷ 25
Wheel rim screws	20 ÷ 25

REAR SUSPENSION

Name	Torque in Nm
Rear wheel axle	104 ÷ 126
Lower shock absorber clamp	33 ÷ 41
Shock absorber/frame nut:	20 ÷ 25

Overhaul data**Assembly clearances****Cylinder - piston assy.****PISTON TO CAST IRON CYLINDER COUPLING**

Name	Initials	Cylinder	Piston	Play on fitting
Coupling	M	56.997 ÷ 57.004	56.944 ÷ 56.951	0.046 ÷ 0.060
Coupling	N	57.004 ÷ 57.011	56.951 ÷ 56.958	0.046 ÷ 0.060
Coupling	O	57.011 ÷ 57.018	56.958 ÷ 56.965	0.046 ÷ 0.060
Coupling	P	57.018 ÷ 57.025	56.965 ÷ 56.972	0.046 ÷ 0.060
Coupling 1st oversize	M1	57.197 ÷ 57.204	57.144 ÷ 57.151	0.046 ÷ 0.060
Coupling 1st oversize	N1	57.204 ÷ 57.211	57.151 ÷ 57.158	0.046 ÷ 0.060
Coupling 1st oversize	O1	57.211 ÷ 57.218	57.158 ÷ 57.165	0.046 ÷ 0.060
Coupling 1st oversize	P1	57.218 ÷ 57.225	57.165 ÷ 57.172	0.046 ÷ 0.060
Coupling 2nd oversize	M2	57.397 ÷ 57.404	57.344 ÷ 57.351	0.046 ÷ 0.060
Coupling 2nd oversize	N2	57.404 ÷ 57.411	57.351 ÷ 57.358	0.046 ÷ 0.060
Coupling 2nd oversize	O2	57.411 ÷ 57.418	57.358 ÷ 57.365	0.046 ÷ 0.060
Coupling 2nd oversize	P2	57.418 ÷ 57.425	57.365 ÷ 57.372	0.046 ÷ 0.060
Coupling 3rd oversize	M3	57.597 ÷ 57.604	57.544 ÷ 57.551	0.046 ÷ 0.060
Coupling 3rd oversize	N3	57.604 ÷ 57.611	57.551 ÷ 57.558	0.046 ÷ 0.060
Coupling 3rd oversize	O3	57.611 ÷ 57.618	57.558 ÷ 57.565	0.046 ÷ 0.060
Coupling 3rd oversize	P3	57.618 ÷ 57.625	57.565 ÷ 57.572	0.046 ÷ 0.060

Piston rings

SEAL RINGS

Name	Description	Dimensions	Initials	Quantity
Compression ring		57 x 1	A	0.15 ÷ 0.30
Oil scraper ring		57x1	A	0.10 ÷ 0.30
Oil scraper ring		57x2.5	A	0.10 ÷ 0.35
Compression ring 1st oversize		57.2 x 1	A	0.15 ÷ 0.30
Oil scraper ring 1st oversize		57.2x1	A	0.10 ÷ 0.30
Oil scraper ring 1st oversize		57.2x2.5	A	0.10 ÷ 0.35
Compression ring 2nd oversize		57.4x1	A	0.15 ÷ 0.30
Oil scraper ring 2nd oversize		57.4x1	A	0.10 ÷ 0.30
Oil scraper ring 2nd oversize		57.4x2.5	A	0.10 ÷ 0.35
Compression ring 3rd oversize		57.6x1	A	0.15 ÷ 0.30
Oil scraper ring 3rd oversize		57.6x1	A	0.10 ÷ 0.30
Oil scraper ring 3rd oversize		57.6x2.5	A	0.10 ÷ 0.35

Maximum clearance after use: 1 mm

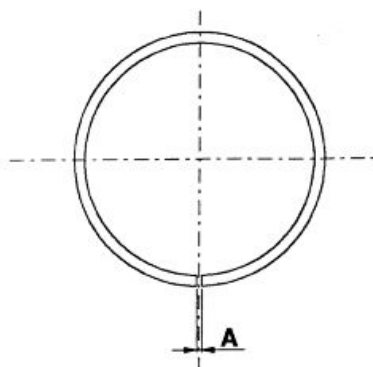

Crankcase - crankshaft - connecting rod

CRANKSHAFT HALF-BEARINGS

Name	Description	Dimensions	Initials	Quantity
Crankshaft half-bearing			Category B - blue	1.973 ÷ 1.976
Crankshaft half-bearing			Type C - yellow	1.976 ÷ 1.979
Crankshaft half-bearing			Category E - green	1.979 ÷ 1.982

CRANKCASE - CRANKSHAFT COUPLINGS

Name	Description	Dimensions	Initials	Quantity
Crankshaft category 1 - Crankcase category 1			E - E	
Crankshaft category 1 - Crankcase category 2			C - C	
Crankshaft class 2 - Crankcase class 1			C - C	
Crankshaft category 2 - Crankcase category 2			B - B	

CRANKSHAFT - CRANKCASE

Name	Description	Dimensions	Initials	Quantity
Crankshaft			Category 1	28.998 ÷ 29.004
Crankshaft			Class 2	29.004 ÷ 29.010
Crankcase			Category 1	32.959 ÷ 32.965
Crankcase			Class 2	32.953 ÷ 32.959

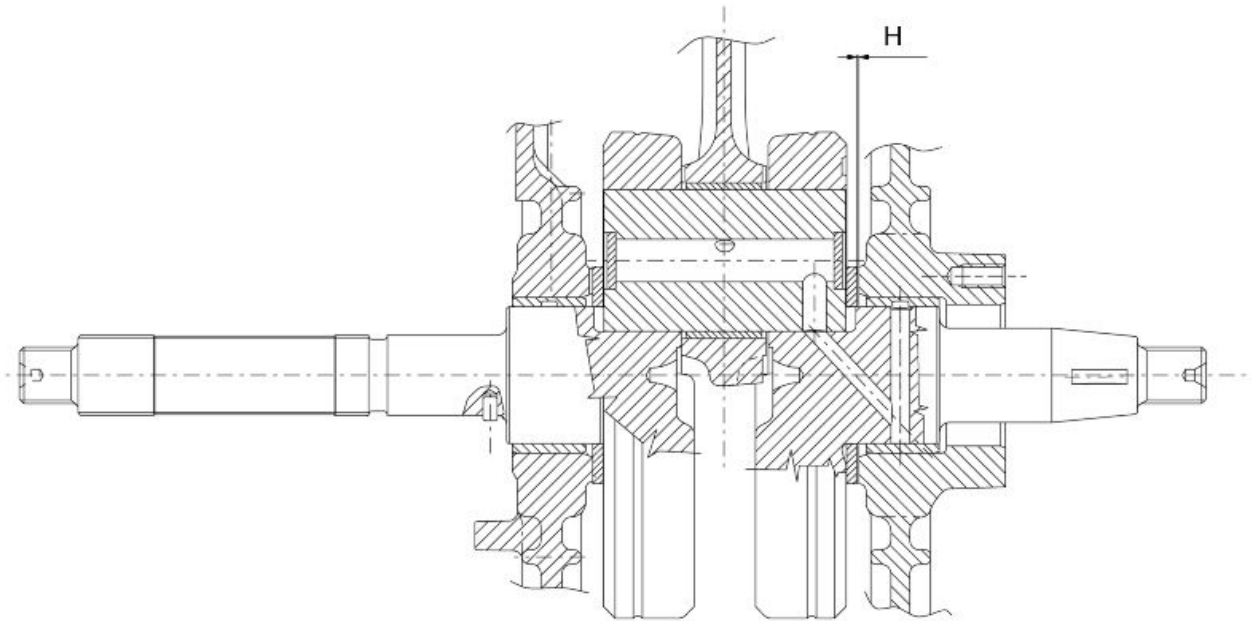
**Fitting clearances****Crankshaft/crankcase axial clearance (H):****0.15 ÷ 0.40 mm (when cold)**

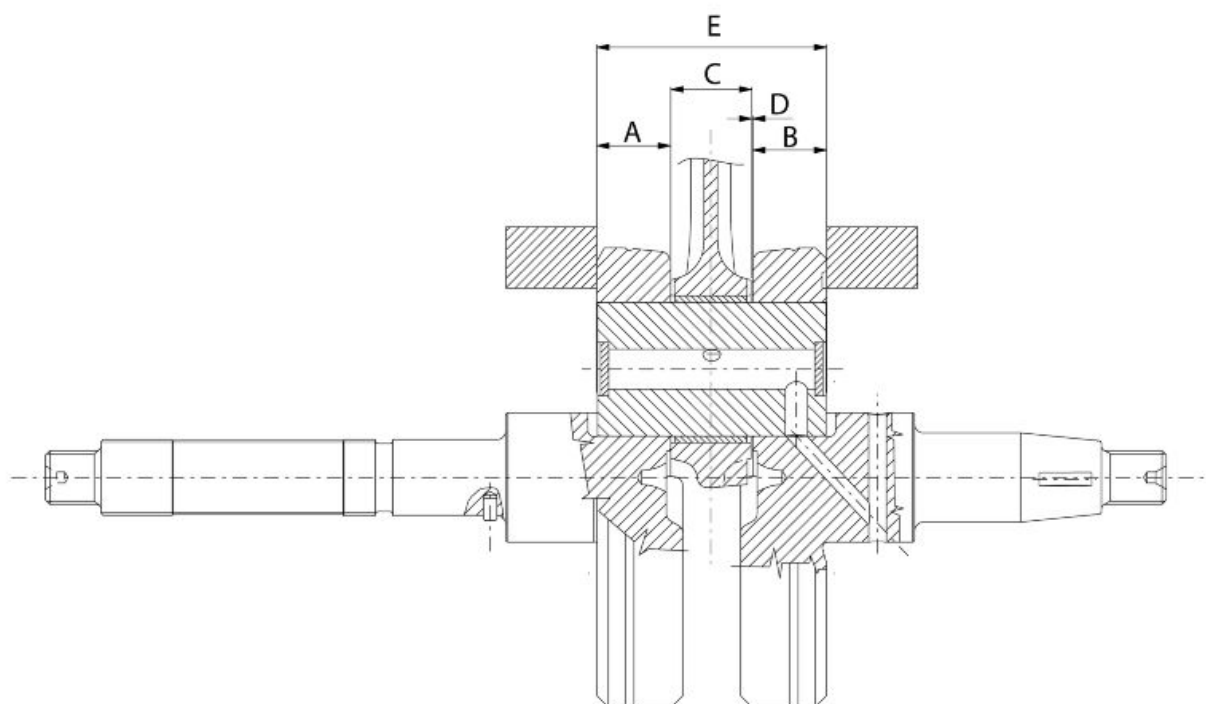

AXIAL CLEARANCE BETWEEN CRANKSHAFT AND CONNECTING ROD

Name	Description	Dimensions	Initials	Quantity
Half-shaft, transmission side		16.6 +0-0.05	A	D = 0.20 - 0.50
Flywheel-side half-shaft		16.6 +0-0.05	B	D = 0.20 - 0.50
Connecting rod		18 -0.10 -0.15	C	D = 0.20 - 0.50
Spacer tool		51.4 +0.05	E	D = 0.20 - 0.50

Slot packing system

- Provisionally fit the piston into the cylinder, without any base gasket.
- Assemble a dial gauge on the specific tool
- Set the dial gauge to zero at a contrast plane with an average preload, for example 5 mm. Keeping the zero setting position, fit the tool on the cylinder and lock it with 2 nuts, as shown in the figure.
- Rotate the crankshaft until TDC (the inverted point of the dial gauge rotation)
- Calculate the difference between the two measurements: use the chart below to identify the thickness of the cylinder base gasket to be used for refitting. Correctly identify the cylinder base gasket thickness to keep the correct compression ratio.
- Remove the special tool and the cylinder.

Characteristic

Compression ratio

12 ± 0.5: 1

SHIMMING SYSTEM

Specification	Desc./Quantity
Value measured	0 ÷ 0.1
Thickness	0.8 ± 0.05
Value measured	0.1 ÷ 0.3
Thickness	0.6 ± 0.05
Value measured	0.3 - 0.4
Thickness	0.4 ± 0.05

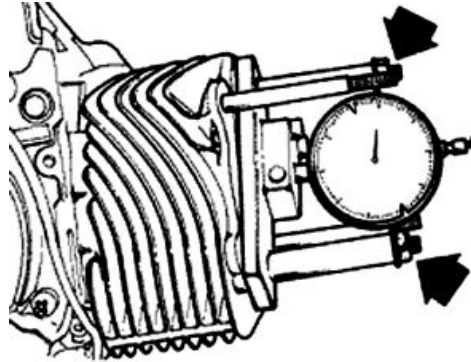
**Products****RECOMMENDED PRODUCTS TABLE**

Product	Description	Specifications
AGIP ROTRA 80W-90	Rear hub oil	SAE 80W/90 Oil that exceeds the requirements of API GL3 specifications
AGIP BRAKE 4	Brake fluid	FMVSS DOT 4 Synthetic fluid
AGIP CITY HI TEC 4T	Oil to lubricate flexible transmissions (brakes, throttle control and odometer)	Oil for 4-stroke engines
AGIP FILTER OIL	Oil for air filter sponge	Mineral oil with specific additives for increased adhesiveness
AGIP CITY HI TEC 4T	Engine oil	SAE 5W-40, API SL, ACEA A3, JASO MA Synthetic oil
AGIP GREASE MU3	Grease for odometer transmission gear case	Soap-based lithium grease with NLGI 3; ISO-L-XBCHA3, DIN K3K-20
AGIP GP 330	Grease for brake control levers, throttle, stand	White calcium complex soap-based spray grease with NLGI 2; ISO-L-XBCIB2

UNIT OF MEASUREMENT - CONVERSION - ENGLISH SYSTEM AND INTERNATIONAL SYSTEM (IS).

Specification	Desc./Quantity
1 Inch (in)	25.4 Millimetres (mm)
1 Foot (ft)	0.305 Meter (m)
1 Mile (mi)	1.609 Kilometre (km)
1 US Gallon (US gal)	3.785 Litre (l)
1 Pound (lb)	0.454 Kilogram (Kg)
1 Cubic inch (in ³)	16.4 Cubic centimetres (cm ³)
1 Foot pound (ft lb)	1.356 Newton meter (Nm)
1 Miles per hour (mi/h)	1.602 Kilometres per hour (km/h)
1 Pound per square inch (PSI)	0.069 (bar)
1 Fahrenheit (°F)	32+(9/5) Celsius (°C)

INDEX OF TOPICS

TOOLING

TOOL

APPROPRIATE TOOLS

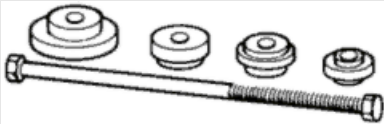
Stores code	Description	
001330Y	Tool for fitting steering seats	

001467Y009	Driver for OD 42-mm bearings	
------------	------------------------------	---

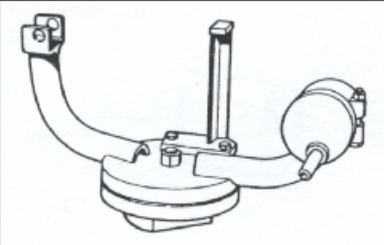

001467Y013	Pliers to extract ø 15-mm bearings	
------------	------------------------------------	---

002465Y	Pliers for circlips	
---------	---------------------	---

005095Y	Engine support	
---------	----------------	---

008564Y	Flywheel extractor	
---------	--------------------	---

Stores code	Description	
020004Y	Punch for removing fifth wheels from headstock	
020055Y	Wrench for steering tube ring nut	
020074Y	Support base for checking crankshaft alignment	
020150Y	Air heater support	
020151Y	Air heater	
020193Y	Oil pressure gauge	

Stores code	Description	
020262Y	Crankcase splitting strip	 A black metal plate with a central vertical rod and four mounting holes at the corners.
020263Y	Sheath for driven pulley fitting	 A black cylindrical sleeve.
020287Y	Clamp to assemble piston on cylinder	 A black flexible strap with a buckle.
020306Y	Punch for assembling valve seal rings	 A black cylindrical tool with a tapered end.
020329Y	MityVac vacuum-operated pump	 A complex mechanical device with various components and a vacuum chamber.
020330Y	Stroboscopic light to check timing	 A handheld stroboscopic light with a power cord.

Stores code	Description	
020331Y	Digital multimeter	

020332Y	Digital rev counter	
---------	---------------------	--

020334Y	Multiple battery charger	
---------	--------------------------	--

020335Y	Magnetic support for dial gauge	
---------	---------------------------------	--

020357Y	32 x 35 mm adaptor	
020359Y	42x47-mm adaptor	

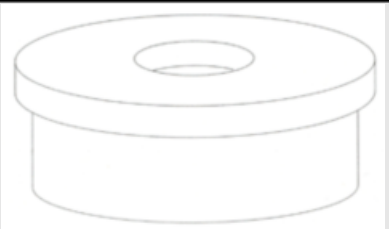

Stores code	Description	
020360Y	Adaptor 52 x 55 mm	

020363Y 20 mm guide



020364Y	25-mm guide	
---------	-------------	--





020368Y driving pulley lock wrench













020375Y	Adaptor 28 x 30 mm	
---------	--------------------	---

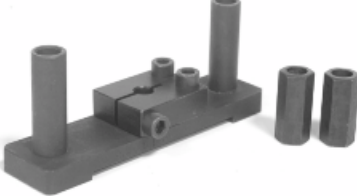

020376Y Adaptor handle



Stores code	Description	
020382Y011	adapter for valve removal tool	
020409Y	Multimeter adaptor - Peak voltage detection	
020412Y	15 mm guide	
020414Y	28-mm guide	
020423Y	driven pulley lock wrench	

Stores code	Description	
020424Y	Driven pulley roller casing fitting punch	
020425Y	Punch for flywheel-side oil seal	
020426Y	Piston fitting fork	
020427Y	Piston fitting band	
020428Y	Piston position check support	
020430Y	Pin lock fitting tool	

Stores code	Description	
020431Y	Valve oil seal extractor	
020434Y	Oil pressure control fitting	
020444Y	Tool for fitting/ removing the driven pulley clutch	
020565Y	Flywheel lock calliper spanner	
020622Y	Transmission-side oil guard punch	
020481Y005	EFI Technology interface wiring	

Stores code	Description	
020460Y	Scooter diagnosis and tester	
020469Y	Reprogramming kit for scooter diagnosis tester	
020641Y	EFI Technology software upgrade	

INDEX OF TOPICS

MAINTENANCE

MAIN

Maintenance chart
EVERY 2 YEARS**Action**

Brake fluid - change

EVERY 3,000 KM**Action**

Engine oil - level check/ top-up

AFTER 1,000 KM

80'

Action

Engine oil - replacement
Hub oil - change
Oil filter (net filter) - clean
Idle speed (*) - adjustment
Throttle lever - adjustment
Steering - adjustment
Brake control levers - greasing
Brake pads - check condition and wear
Brake fluid level - check
Safety locks - check
Electrical system and battery - check
Tyre pressure and wear - check
Vehicle and brake test - road test

(*) See instructions in the «Idle speed adjustment» section

AFTER 6,000 KM; 18,000 KM; 54,000 KM

150'

Action

Engine oil - replacement
Hub oil level - check
Spark plug / electrode gap - check
Air filter - clean
Engine oil - change
Oil filter (net filter) - clean
Valve clearance - adjustment
Variable speed rollers/pads - check
Driving belt - checking
Brake pads - check condition and wear
Brake fluid level - check
Electrical system and battery - check
Centre stand - lubrication
Tyre pressure and wear - check
Vehicle and brake test - road test

AFTER 12,000 KM; 60,000 KM

160'

Action

Engine oil - replacement
Hub oil level - check
Air filter - clean
Engine oil - change
Oil filter (net filter) - clean
Spark plug - replacement
Idle speed (*) - adjustment
Throttle lever - adjustment
Pads and variator rollers - replacement

Action

Driving belt - replacement
Odometer gear - greasing
Steering - adjustment
Brake control levers - greasing
Brake pads - check condition and wear
Brake fluid level - check
Transmission elements - lubrication
Safety locks - check
Suspensions - check
Electrical system and battery - check
Headlight - adjustment
Centre stand - lubrication
Secondary air filter - cleaning
Tyre pressure and wear - check
Vehicle and brake test - road test

(*) See instructions in the «Idle speed adjustment» section

AFTER 24,000 KM; 48,000 KM

175'

Action

Engine oil - replacement
Hub oil - change
Air filter - clean
Engine oil - change
Oil filter (net filter) - clean
Spark plug - replacement
Idle speed (*) - adjustment
Throttle lever - adjustment
Pads and variator rollers - replacement
Driving belt - replacement
Cylinder ventilation system - cleaning
Odometer gear - greasing
Steering - adjustment
Brake control levers - greasing
Brake pads - check condition and wear
Brake fluid level - check
Transmission elements - lubrication
Safety locks - check
Suspensions - check
Electrical system and battery - check
Headlight - adjustment
Tyre pressure and wear - check
Secondary air filter - cleaning
Centre stand - lubrication
Vehicle and brake test - road test

(*) See instructions in the «Idle speed adjustment» section

AFTER 30,000 KM; 42,000 KM; 66,000 KM

95'

Action

Engine oil - replacement
Hub oil level - check
Spark plug / electrode gap - check
Air filter - clean
Engine oil - change
Oil filter (net filter) - clean
Variable speed rollers/pads - check
Driving belt - checking
Brake pads - check condition and wear
Brake fluid level - check
Electrical system and battery - check
Centre stand - lubrication
Tyre pressure and wear - check
Vehicle and brake test - road test

AFTER 36,000 KM

270'

Action
Engine oil - replacement
Hub oil - change
Spark plug - replacement
Air filter - clean
Engine oil - change
Oil filter (net filter) - clean
Valve clearance - adjustment
Idle speed (*) - adjustment
Throttle lever - adjustment
Pads and variator rollers - replacement
Driving belt - replacement
Odometer gear - greasing
Steering - adjustment
Brake control levers - greasing
Brake pads - check condition and wear
Brake fluid level - check
Flexible brake tubes - replacement
Transmission elements - lubrication
Safety locks - check
Suspensions - check
Electrical system and battery - check
Headlight - adjustment
Secondary air filter - cleaning
Centre stand - lubrication
Tyre pressure and wear - check
Vehicle and brake test - road test

(*) See instructions in the «Idle speed adjustment» section

AFTER 72,000 KM

270'

Action
Engine oil - replacement
Hub oil - change
Spark plug - replacement
Air filter - clean
Engine oil - change
Oil filter (net filter) - clean
Valve clearance - adjustment
Idle speed (*) - adjustment
Throttle lever - adjustment
Pads and variator rollers - replacement
Driving belt - replacement
Odometer gear - greasing
Steering - adjustment
Cylinder ventilation system - check
Brake control levers - greasing
Brake pads - check condition and wear
Brake fluid level - check
Flexible brake tubes - replacement
Transmission elements - lubrication
Safety locks - check
Suspensions - check
Electrical system and battery - check
Headlight - adjustment
Secondary air filter - cleaning
Centre stand - lubrication
Tyre pressure and wear - check
Vehicle and brake test - road test

(*) See instructions in the «Idle speed adjustment» section

Checking the spark advance

The scooter is fitted with a control unit that manages ignition advance according to engine revs and the opening angle of the carburettor throttle valve.

LIMITER ACTIVATION

Specification	Desc./Quantity
Operation threshold	First threshold : 9500 ± 50 Second threshold : 9800 ± 50
Reactivation threshold	First threshold : 9500 ± 50 Second threshold : 9350 ± 50
Spark elimination	First threshold : 15 on 15 Second threshold : 15 on 15

Spark plug

In order to inspect the spark plug, follow the operation described when the engine is cold:

1. Lift the saddle and remove the helmet compartment «A».
2. Remove the spark plug inspection door «B».
3. Detach the spark plug cap.
4. Slide the door «C» on the engine cover upwards and off.
5. Remove the spark plug with the spanner «D» supplied (with retaining rubber ring).

To refit, repeat the procedure in reverse order using the spanner to insert the spark plug or to tighten it in its seat. Care should be taken to installing and fixing it with correct inclination

Be extremely careful when carrying out the operations described above, insert your left hand on the spark plug inspection door side and your right hand from the helmet compartment side.

To refit the door follow the steps in reverse order, making sure to insert the pin in the central cover.

CAUTION



THE SPARK PLUG MUST BE REMOVED WHEN THE ENGINE IS COLD. THE USE OF SPARK PLUGS OF DIFFERENT THERMAL GRADE FROM THAT REQUIRED OR WITH INAPPROPRIATE THREADS MAY SERIOUSLY DAMAGE THE ENGINE.

N.B.

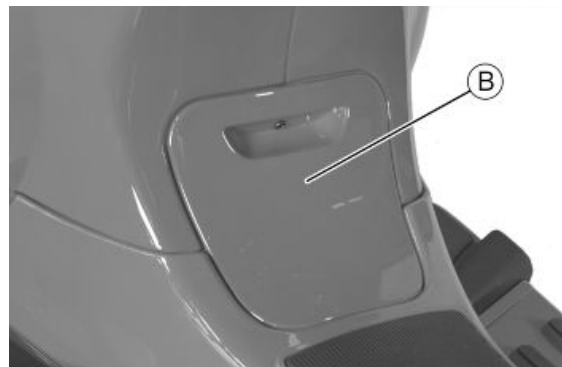
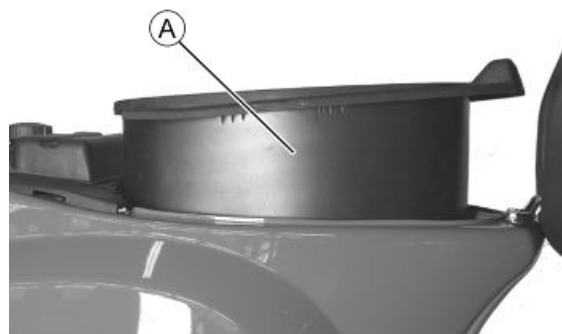

THE USE OF SPARK PLUGS OTHER THAN THE INDICATED TYPE OR OF SHIELDLESS SPARK PLUG CAPS CAN CAUSE ELECTRICAL SYSTEM FAILURES.

Characteristic

Spark plug

CHAMPION RG 6 YC

Alternative spark plug

NGK CR7EB

Electrode gap

0.7 ÷ 0.8 mm

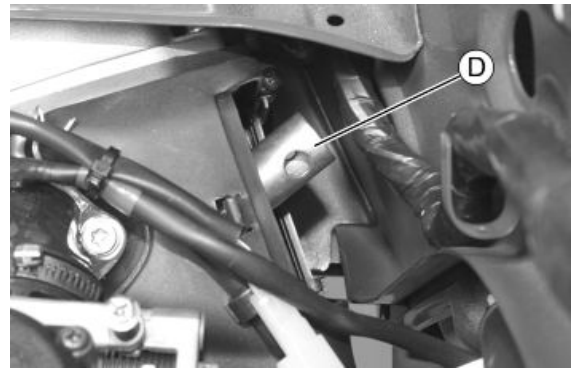

Hub oil

Check

- Park the vehicle on its centre stand on flat ground;
- Remove the oil dipstick «A», dry it with a clean cloth and put it back into its hole **tightening it completely**;

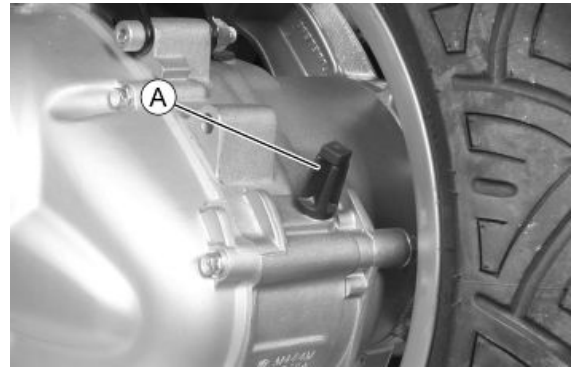

Remove the dipstick and check that the oil level is slightly over the second notch starting from the lower end; if the level is below the **MAX** mark, it needs to be filled up with the right amount of hub oil.

- Screw up the oil dipstick again and make sure it is locked properly into place.

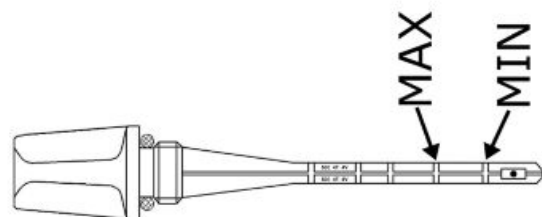

Replacement

- Unscrew the oil filling cap/dipstick «A».



- Remove the rear wheel, place a suitable container, unscrew the drainage screw «B» and let the oil flow out completely.

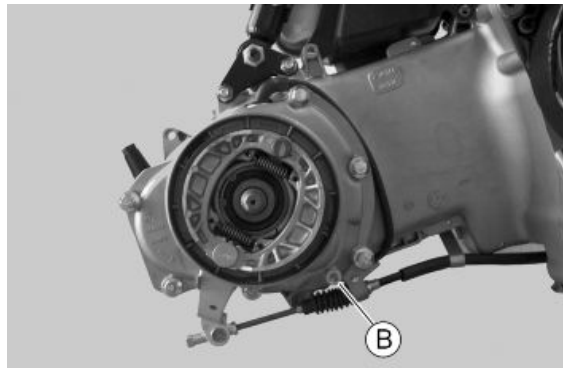

- Once the oil has been drained off, tighten the filling screw to the prescribed torque.
- Fill with the recommended product to the prescribed amount.

Recommended products

AGIP ROTRA 80W-90 rear oil hub

SAE 80W/90 Oil that exceeds the requirements of API GL3 specifications

Characteristic

Rear hub oil

250 cc

Locking torques (N*m)

Hub oil drainage cap 15 ÷ 17

Air filter

- Remove the side fairing by undoing the screw «A» and the smaller screw «B».
- Take out the air cleaner cover «D» after undoing the six fixing screws «C», then take out the filtering element.

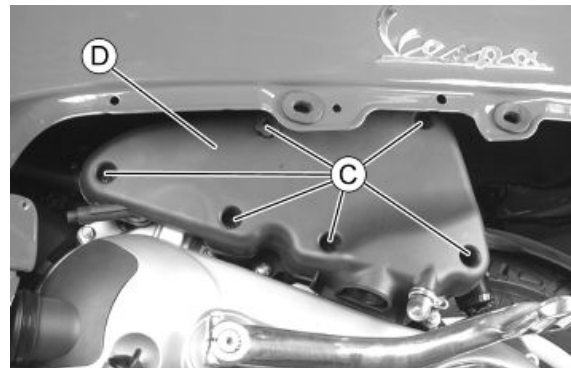
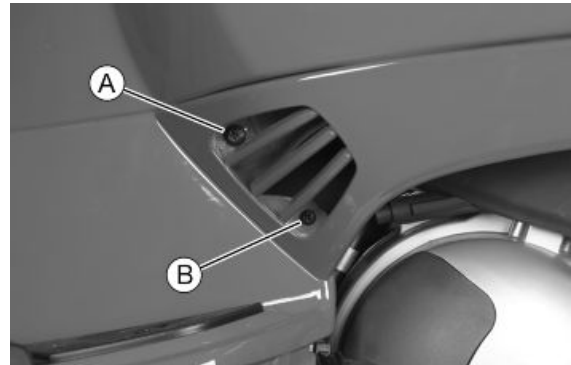

1. Wash the sponge with water and neutral soap.
2. Dry it with a clean cloth and small blasts of compressed air.
3. Impregnate the sponge with a mixture of 50% petrol and 50% specified oil.
4. Gently squeeze the filter element, let it drip and then refit it.

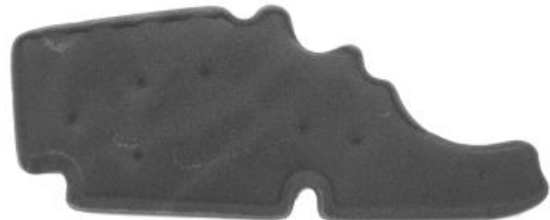

CAUTION



IF THE VEHICLE IS USED ON DUSTY ROADS, IT IS NECESSARY TO SERVICE THE AIR FILTER MORE OFTEN TO AVOID DAMAGING THE ENGINE.

Recommended products

AGIP FILTER OIL Oil for air filter sponge

Mineral oil with specific additives for increased adhesiveness

Engine oil

In 4T engines, the engine oil is used to lubricate the distribution elements, the bench bearings and the thermal group. **An insufficient quantity of oil can cause serious damage to the engine.**

In all 4T engines, the deterioration of the oil characteristics, or a certain consumption should be considered normal, especially if during the run-in period. Consumption levels in particular can be influenced by the conditions of use (e.g.: oil consumption increases when driving at "full throttle").

Replacement

Replace oil and filter as indicated in the scheduled maintenance table. The engine should be emptied by draining the oil through the drainage cap «B» of the mesh pre-filter.



Moreover, to facilitate oil drainage, remove the mesh pre-filter and unscrew the cap/dipstick «A».



Once all the oil has drained through the drainage hole, unscrew and remove the oil cartridge filter «C».



Make sure the pre-filter and discharge tap O-rings are in good condition.

Lubricate them and refit the mesh filter and oil drainage plug, screwing them up to the specified torque.

Refit the new cartridge filter being careful to lubricate the O-ring before fitting it.

Change the engine oil.

Since a certain quantity of oil still remains in the circuit, engine oil must be added through the plug «A». Then start up the scooter, leave it running for a few minutes and switch it off: after five minutes check the level and if necessary top up without exceeding the **MAX** level. The cartridge filter must be replaced every time the oil is changed. Use new oil of the recommended type for topping up and changing purposes.

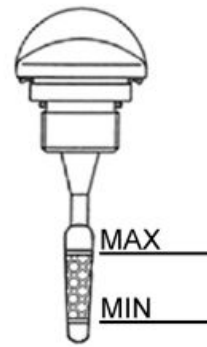

Characteristic

Engine oil

1.10 l

Locking torques (N*m)

Engine oil drainage plug 24 ÷ 30 Oil filter 4 ÷ 6

Check

Every time the scooter is used, a visual check should be made on the level of the engine oil when the engine is cold. The oil level should be somewhere between the **MAX** and **MIN** index marks on the level bar; the check must be made with the scooter upright, resting on the centre stand.

If the check is carried out after the vehicle has been used, and therefore with a hot engine, the level line will be lower; in order to carry out a correct check, wait at least 10 minutes after the engine has been stopped so as to get the correct level.

CAUTION





USING THE ENGINE WITH INSUFFICIENT LUBRICATION OR WITH THE WRONG LUBRICANTS MAY INCREASE WEAR AND TEAR ON THE MOVING PARTS AND MAY CAUSE SERIOUS DAMAGE.

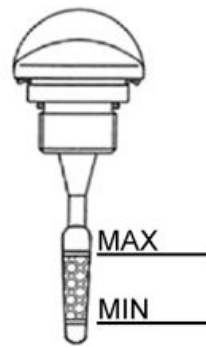

Always check oil level before carrying out top-ups and add oil **without exceeding the MAX level**. An engine oil check-up and top-up should be carried out as indicated in the scheduled maintenance table at an **Authorised Service Centre**.

Engine oil filter

CAUTION

DO NOT DISPOSE OF OIL IN THE ENVIRONMENT. OIL, GASKET AND FILTER SHOULD BE DISPOSED OF ACCORDING TO THE REGULATIONS IN FORCE.

WARNING

AVOID TOUCHING PARTS OF THE ENGINE WHEN HOT, AS THIS MAY CAUSE BURNS.

The cartridge filter must be replaced every time the oil is changed. Use new oil of the recommended type for topping up and changing purposes.

Make sure the pre-filter and drainage plug O-rings are in good conditions. Lubricate them and refit the mesh filter and oil drainage plug, screwing them up to the specified torque. Refit the new cartridge filter being careful to lubricate the O-ring before fitting it. Change the engine oil.

Recommended products

AGIP CITY HI TEC 4T Engine oil

SAE 5W-40 Synthetic oil that exceed the requirements of API SL, ACEA A3, JASO MA specifications

Oil pressure warning light

The vehicle is equipped with a warning light on the instrument panel that lights up when the key is turned to the «ON» position. However, this light should switch off once the engine has been started.

If the light turns on during braking, at idling speed or while turning a corner, it is necessary to check the oil level and the lubrication system.

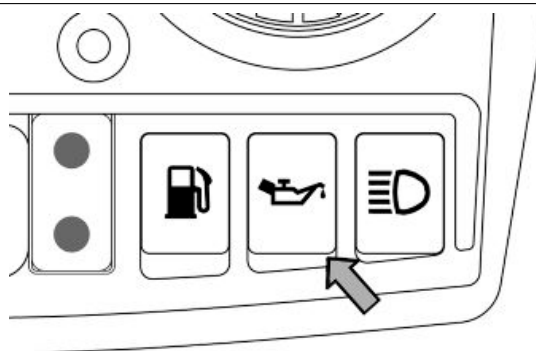

Fuel filter

- Remove the helmet compartment in order to reach the fuel filter.
- Disconnect the pipe connecting clamps to remove the filter.

CAUTION

THE TANK DOES NOT HAVE A COCK, SO PLACE A SUITABLE CONTAINER TO COLLECT THE FUEL.



Checking the ignition timing

- Remove the 4 fixing screws and detach the flywheel cover from the engine.
- Rotate the flywheel until the reference matches the crankcase operation end as shown in the figure (TDC). Make sure that the 4V reference point on the camshaft control pulley is aligned with the reference point on the head as shown in the second figure. If the reference mark is opposite the indicator on the head, make the crankshaft turn once more.
- The TDC reference mark is repeated also between the flywheel cooling fan and the flywheel cover.

To use this reference mark, remove the spark plug and turn the engine in the opposite direction to the normal direction using a calliper spanner applied to the camshaft command pulley casing.

N.B.

TIME THE TIMING SYSTEM UNIT IF IT IS NOT IN PHASE.

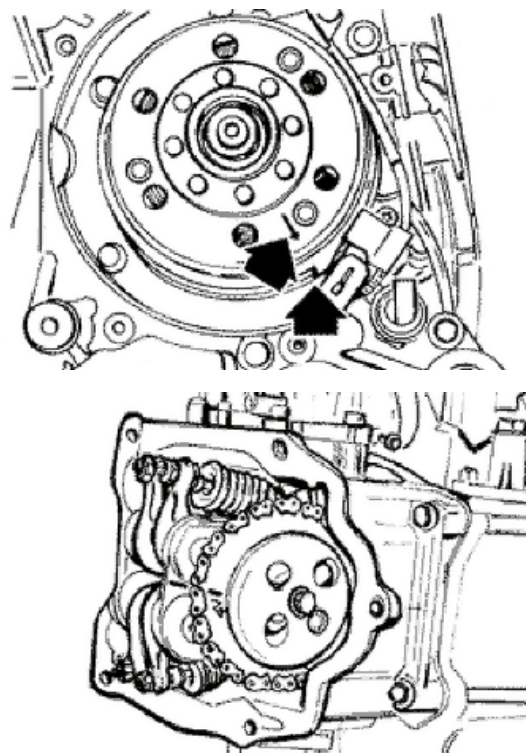

Checking the valve clearance

- To check valve clearance, centre the reference marks of the timing system.
- Use a thickness gauge to check that the clearance between the valve and the set screw corresponds with the indicated values. When the valve clearance values, intake and drainage respectively, are different from the ones indicated below, adjust them by loosening the lock nut and operate on the register with a screwdriver as shown in the figure.

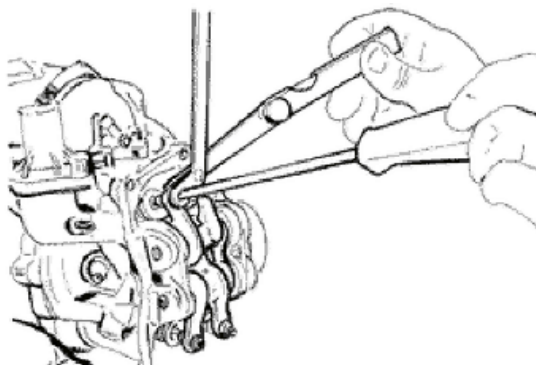

Characteristic

Valve clearance

Inlet: 0.10 mm (when cold)

Outlet: 0.15 mm (when cold)

Braking system

Level check

- Rest the vehicle on its centre stand on flat ground.
- The brake fluid reservoir has a sight glass «A» made of transparent material; the quantity of liquid contained in the sight glass indicates the level of fluid in the reservoir.
- When the sight glass «A» is full, the level inside the reservoir is above the MIN level; when it is partially full, the level has dropped to the MIN level; when it is fully empty, the level of fluid in the reservoir is below the MIN level.

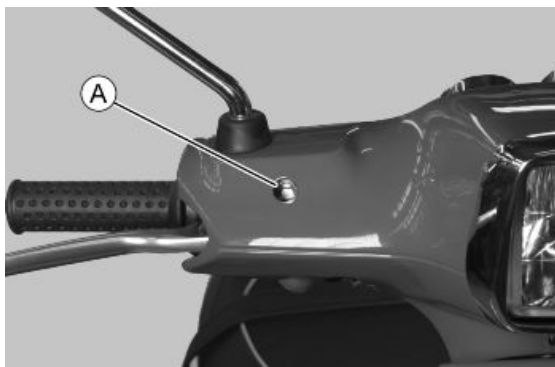

N.B.

THE LEVEL TENDS TO DROP AS THE BRAKE PADS GET WORN, A MINIMUM LEVEL SHOULD NOT BE REACHED. IF THE LEVEL IS TOO LOW, CHECK AND FIX THE SYSTEM SEALS, IF REQUIRED. TOP UP THE PUMP TANK, IF REQUIRED, CONSIDERING THAT THE "MAX." LEVEL MUST ONLY BE OBTAINED WITH NEW PADS.

- Under standard climatic conditions, replace fluid as indicated in the scheduled maintenance table.

Top-up

Proceed as follows:

- Remove the rear-view mirrors.
- Undo the two screws «A».

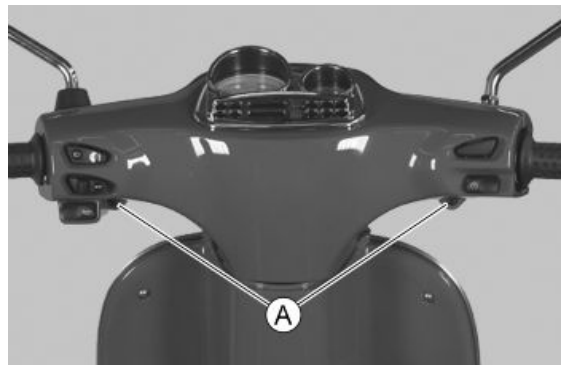

- Undo the screw «B» and remove the front handlebar cover.



- Remove the reservoir cover «C» by loosening the two fixing screws «D» and refill with the prescribed brake fluid type only and without exceeding the maximum level.

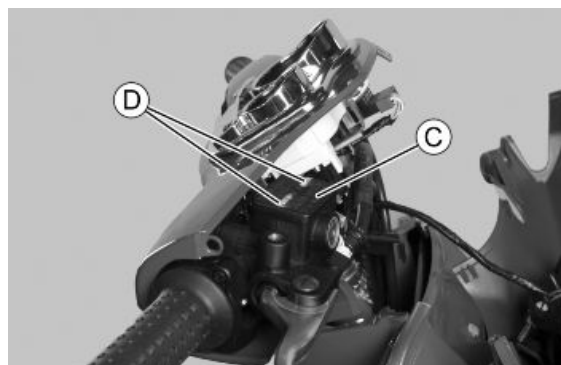

CAUTION

ONLY USE DOT 4-CLASSIFIED BRAKE FLUID.

CAUTION



AVOID CONTACT OF THE BRAKE FLUID WITH YOUR EYES, SKIN, AND CLOTHING. IN CASE OF ACCIDENTAL CONTACT, WASH WITH WATER.

CAUTION

BRAKING CIRCUIT FLUID IS HIGHLY CORROSIVE; MAKE SURE THAT IT DOES NOT COME INTO CONTACT WITH THE PAINTWORK.

CAUTION

BRAKE FLUID IS HYGROSCOPIC; THAT IS, IT ABSORBS MOISTURE FROM THE SURROUNDING AIR. IF THE CONTENT OF MOISTURE IN THE BRAKE FLUID EXCEEDS A CERTAIN VALUE, BRAKING WILL BE INEFFICIENT. NEVER USE BRAKE FLUID FROM OPEN OR PARTIALLY USED CONTAINERS. UNDER NORMAL CLIMATIC CONDITIONS, REPLACE FLUID AS INDICATED IN THE SCHEDULED MAINTENANCE TABLE.

N.B.

SEE THE BRAKING SYSTEM CHAPTER WITH REGARD TO THE CHANGING OF BRAKE FLUID AND THE BLEEDING OF AIR FROM THE CIRCUITS.

Recommended products

AGIP BRAKE 4 Brake fluid

FMVSS DOT 4 Synthetic fluid

Headlight adjustment

Proceed as follows:

1. Place the vehicle in running order and with the tyres inflated to the prescribed pressure, on a flat surface 10 m away from a white screen situated in a shaded area, making sure that the longitudinal axis of the scooter is perpendicular to the screen;
2. Turn on the headlight and check that the borderline of the projected light beam on the screen is not lower than 9/10 of the distance from the ground to the centre of vehicle headlamp and higher than 7/10;
3. If otherwise, adjust the right headlight with screw «A».

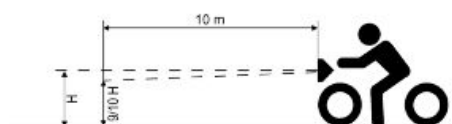

N.B.

THE ABOVE PROCEDURE COMPLIES WITH THE EUROPEAN STANDARDS REGARDING MAXIMUM AND MINIMUM HEIGHT OF LIGHT BEAMS. REFER TO THE STATUTORY REGULATIONS IN FORCE IN EVERY COUNTRY WHERE THE vehicle IS USED.

SAS filters inspection and cleaning

Proceed as follows:

- Remove the right-hand side fairing
- Remove the screw on the rear part, to the right of the footrest, indicated in the photograph
- Remove the spoiler terminal





- Remove the screw fixing the SAS valve to the flywheel cover, indicated in the photograph.

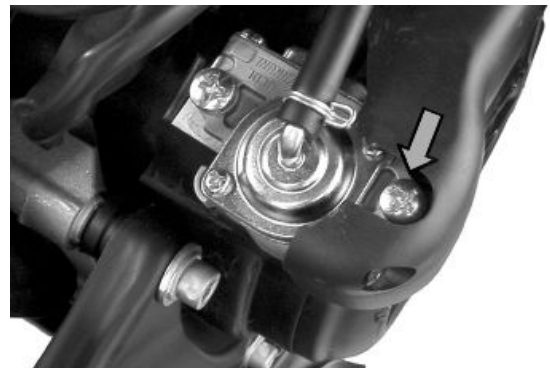

- Remove the 6 flywheel cover screws indicated in the photograph and remove the flywheel cover.

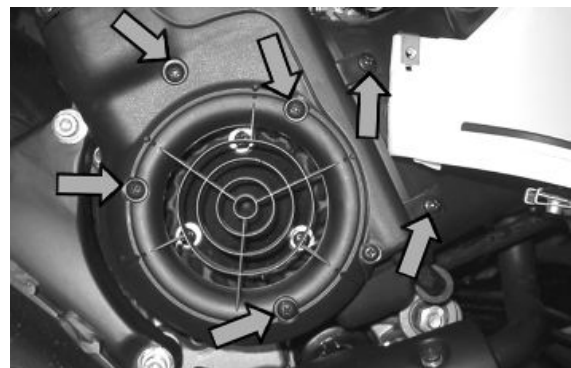

- Remove the filter indicated in the photograph
- Check that the gasket is in good conditions
- Check the SAS filter housing for dents or deformations
- Clean the SAS filter carefully. Replace the filter if it is damaged or deformed.



To refit, carry out the removal operations but in reverse order.

CAUTION
 WHEN TRAVELLING ON DUSTY ROADS, THE AIR FILTER MUST BE CLEANED MORE OFTEN THAN SHOWN IN THE SCHEDULED MAINTENANCE CHART.

CAUTION
 NEVER RUN THE ENGINE WITHOUT THE SECONDARY AIR FILTER

INDEX OF TOPICS

TROUBLESHOOTING

TROUBL

Engine

Poor performance
POOR PERFORMANCE

Possible Cause	Operation
Air filter blocked or dirty.	Remove the sponge, wash with water and car shampoo, then soak it in a mixture of 50% petrol and 50% specific oil. Press with your hand without squeezing, allow it to drip dry and refit.
Fuel nozzles or cock clogged or dirty	Dismantle, wash with solvent and dry with compressed air
Dirty or faulty vacuum-operated cock	Check the filter on the cock, remove the petrol and wash the tank, if necessary. Replace the cock as a last resource.
Failing automatic starter on the carburettor	Check the electrical wiring and mechanical movement, replace if necessary.
Excessive driving belt wear	Check it and replace, if necessary
Lack of compression: parts, cylinder and valves worn	Replace the worn parts
Oil level exceeds maximum	Check for causes and fill to reach the correct level
Excess of encrustations in the combustion chamber	Descale the cylinder, the piston, the head and the valves
Incorrect timing or worn timing system elements	Time the system again or replace the worn parts
Muffler obstructed	Replace
Inefficient automatic transmission	Check the rollers and the pulley movement, replace the damaged parts and lubricate the movable guide of the driven pulley with grease.
Wrong valve adjustment	Adjust the valve clearance properly
Overheated valves	Remove the head and the valves, grind or replace the valves
Valve seat distorted	Replace the head assembly
Worn cylinder, Worn or broken piston rings	Replace the piston cylinder assembly or just the piston rings

Rear wheel spins at idle
REAR WHEEL ROTATES WITH ENGINE AT IDLE

Possible Cause	Operation
Idling rpm too high	Adjust the engine idle speed.
Clutch fault	Check the springs / clutch masses

Starting difficulties
DIFFICULTY STARTING UP

Possible Cause	Operation
Battery flat	Check the state of the battery. If it shows signs of sulphation replace it and bring the new battery into service charging it for eight hours at a current of 1/10 of the capacity of the battery itself
Faulty spark plug or incorrect ignition advance - Engine flooded.	Replace the spark plug or check the ignition circuit components Try starting-up with the throttle fully open. If the engine fails to start, remove the spark plug, dry it and before refitting, make the motor turn so as to expel the fuel excess taking care to connect the cap to the spark plug, and this in turn to the ground. If the fuel tank is empty, refuel and start up.
Incorrect valve sealing or valve adjustment	Inspect the head and/or restore the correct clearance
Rpm too low at start-up or engine and start-up system damaged	Check the starter motor and the kick-starter unit
Altered fuel characteristics	Drain off the fuel no longer up to standard; then, refill
Failing automatic starter on the carburettor	Check the electrical wiring and mechanical movement, replace if necessary.
Start-up enabling buttons failure	Check continuity using an Ohm meter, with the switch pressed; replace if necessary

Possible Cause	Operation
Carburettor nozzles clogged or dirty	Dismantle, wash with solvent and dry with compressed air
Air filter obstructed or dirty.	Remove the sponge, wash with water and car shampoo, then soak it in a mixture of 50% petrol and 50% specific oil. Press with your hand without squeezing, allow it to drip dry and refit.
Fuel pump fault	Check the pump control device

Excessive oil consumption/Exhaust smoke

EXCESSIVE OIL CONSUMPTION/SMOKEY EXHAUST

Possible Cause	Operation
Worn valve guides	Check and replace the head unit if required
Worn valve oil guard	Replace the valve oil guard
Oil leaks from the couplings or from the gaskets	Check and replace the gaskets or restore the coupling seal
Worn or broken piston rings or piston rings that have not been fitted properly	Replace the piston cylinder unit or just the piston rings

Insufficient lubrication pressure

POOR LUBRICATION PRESSURE

Possible Cause	Operation
By-Pass remains open	Check the By-Pass and replace if required. Carefully clean the By-Pass area.
Oil pump with excessive clearance	Perform the dimensional checks on the oil pump components
Oil filter too dirty	Replace the cartridge filter
Oil level too low	Restore the level adding the recommended oil type

Engine tends to cut-off at full throttle

THE MOTOR TENDS TO STOP AT MAXIMUM THROTTLE

Possible Cause	Operation
Maximum jet clogged	Remove the carburettor, wash with solvent and dry with compressed air
Water or condensate in the carburettor tank	Remove the tank, wash with solvent and dry with compressed air
Level in tank too low	Restore the level in the tank by bending on the float the thrusting reed of the petrol inlet rod so as to have the float parallel to the tank level with the carburettor inverted.

Engine tends to cut-off at idle

THE ENGINE TENDS TO STOP AT IDLE SPEED

Possible Cause	Operation
Incorrect idle adjustment	Adjust using the rpm indicator
Incorrect timing	Time the system and check the timing system components
The starter remains on	Check: electric wiring, circuit not interrupted, mechanical movement and power supply; replace if necessary
Faulty spark plug or incorrect ignition advance	Replace the spark plug or check the ignition circuit components
Pressure too low at the end of compression	Check the thermal group seals and replace worn components
Minimum nozzle dirty	Wash the nozzle with solvent and dry with compressed air

High fuel consumption

EXCESSIVE FUEL CONSUMPTION

Possible Cause	Operation
Air filter blocked or dirty. Starter inefficient	Clean according to the procedure Check: electric wiring, circuit continuity, mechanical sliding and power supply
Loose nozzles	Check the maximum and minimum nozzles are adequately fixed in their fittings
Incorrect float level	Restore the level in the tank by bending on the float the thrusting reed of the petrol inlet rod so as to have the float parallel to the tank level with the carburettor inverted.

Transmission and brakes

Clutch grabbing or performing inadequately

IRREGULAR CLUTCH PERFORMANCE OR SLIPPAGE

Possible Cause	Operation
Slippage or irregular functioning	Check that there is no grease on the masses. Check that the faying surface between the clutch masses and the clutch bell is mainly in the middle and with equivalent specifications on the three masses. Check that the clutch bell is not scored or worn abnormally Never run the engine without the clutch bell

Insufficient braking

INEFFICIENT OR NOISY BRAKING

Possible Cause	Operation
Worn brake pads or shoes	Replace the brake pads or shoes and check for brake disk or drum wear conditions.
Front brake disk loose or deformed	Check the brake disc screws are locked; use a dial gauge and a wheel mounted on the vehicle to measure the axial shift of the disc.
Air bubbles inside the hydraulic braking system	Carefully bleed the hydraulic braking system, (there must be no flexible movement of the brake lever).
Fluid leakage in hydraulic braking system	Failing elastic fittings, plunger or brake pump seals, replace
Excessive backlash in the rear brake control cable	Adjust the backlash with the appropriate adjuster located on the back part of the crankcase.

Brakes overheating

BRAKES OVERHEATING

Possible Cause	Operation
Compensation holes on the pump clogged	Clean carefully and blast with compressed air
Brake disc slack or distorted	Check the brake disc screws are locked; use a dial gauge and a wheel mounted on the vehicle to measure the axial shift of the disc.
Defective sliding of pistons	Replace the calliper.

Electrical system

Battery

BATTERY

Possible Cause	Operation
Battery	The battery is the electrical device in the system that requires the most frequent inspections and thorough maintenance. If the vehicle is not used for some time (1 month or more) the battery needs to be recharged periodically. The battery runs down completely in the course of 5 ÷ 6 months. If the battery is fitted on a motorcycle, be careful not to invert the connections, keeping in mind that the black ground wire is connected to the negative terminal while the red wire is connected to the terminal marked+. Follow the instructions in the ELECTRICAL SYSTEM chapter for the recharging of the batteries.

Turn signal lights malfunction

TURN INDICATORS NOT WORKING

Possible Cause	Operation
Electronic ignition device failure	With the key switch set to "ON" jump the contacts 2 (Blue-Black) and 9 (Orange) on the electronic control unit connector. If by operating the turn indicator control the lights are not steadily on, replace the control unit; otherwise, check the cable harness and the switch.

Steering and suspensions

Heavy steering

STEERING HARDENING

Possible Cause	Operation
Steering hardening	Check the tightening of the top and bottom ring nuts. If irregularities in turning the steering continue even after making the above adjustments, check the seats on which the ball bearings rotate: replace them if they are recessed or if the balls are flattened.

Excessive steering play

EXCESSIVE STEERING CLEARANCE

Possible Cause	Operation
Excessive steering backlash	Check the tightening of the top ring nut. If irregularities continue in turning the steering even after making the above adjustments, check the seats in which the ball bearings rotate: replace if they are recessed.

Noisy suspension

NOISY SUSPENSION

Possible Cause	Operation
Noisy suspension	If the front suspension is noisy, check: that the front shock absorber works properly and the ball bearings are good condition. Finally, check the locking torque of the wheel axle nut, the

Possible Cause**Operation**

brake calliper and the disc. Check that the swinging arm connecting the engine to the chassis and the rear shock absorber work properly.

Suspension oil leakage**OIL LEAKAGE FROM SUSPENSION****Possible Cause****Operation**

Oil leakage from suspension

Replace the damper.

INDEX OF TOPICS

ELECTRICAL SYSTEM

ELE SYS

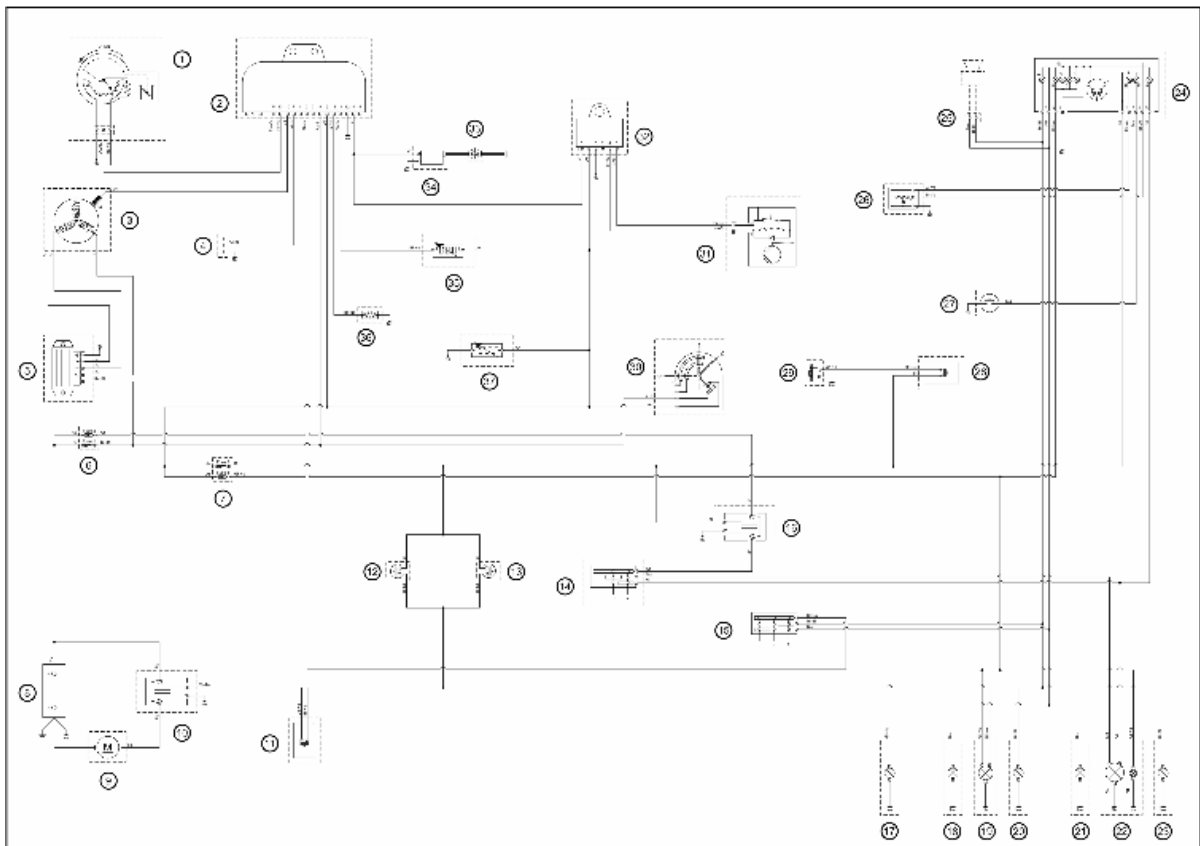
**KEY**

1. Throttle body position
2. Electronic ignition device
3. Magneto flywheel - Pick-up
4. Diagnostics socket
5. Voltage regulator
6. Main fuses
7. Auxiliary fuses
8. 12V-10Ah Battery
9. Starter motor
10. Start-up remote control switch
11. Starter button
12. Stop button on rear brake
13. Stop button on front brake
14. Light switch
15. Turn indicator switch
16. Light remote control
17. License plate light bulb
18. Rear left turn indicator bulb
19. Tail light and rear stop light bulb

- 20. Rear right turn indicator bulb
- 21. Front left turn indicator bulb
- 22. Headlight
 - A. Low-/high-beam twin filament bulb
 - B. Front tail light bulb
- 23. Front right turn indicator bulb
- 24. Instrument panel
 - A. Turn indicator warning light
 - B. Headlight warning light
 - C. Instrument panel lighting bulbs
 - D. Fuel gauge
 - E. Low fuel warning light
 - F. Oil warning light
 - G. High-beam warning light
- 25. Turn indicators sound alarm wiring
- 26. Fuel level transmitter
- 27. Engine oil pressure sensor
- 28. Horn button
- 29. Horn
- 30. Key switch
- 31. Fuel pump
- 32. Fuel electric pump control device
- 33. Spark plug
- 34. HV coil
- 35. Automatic starter
- 36. Temperature sensor
- 37. Carburettor heater

KEY

Ar: Orange **Az:** Sky Blue **Bi:** White **Bl:** Blue **Gi:** Yellow **Gr:** Grey **Ma:** Brown **Ne:** Black **Ro:** Pink **Rs:** Red **Ve:** Green **Vi:** Purple

Components arrangement



3. Magneto flywheel - Pick-up: remove the helmet compartment to reach it.

- Stator phases resistance values:

Electric characteristic

Ohm value:

0.7 ÷ 0.9 Ohm

Pick-up resistance value

105 ÷ 124 Ohm

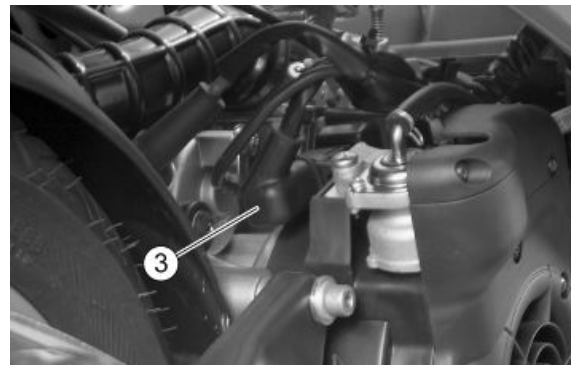

1 / 4 / 9 / 31 / 35 - Throttle body position / Diagnostics socket / Starter motor / Fuel pump / Automatic starter: remove the helmet compartment to reach it.

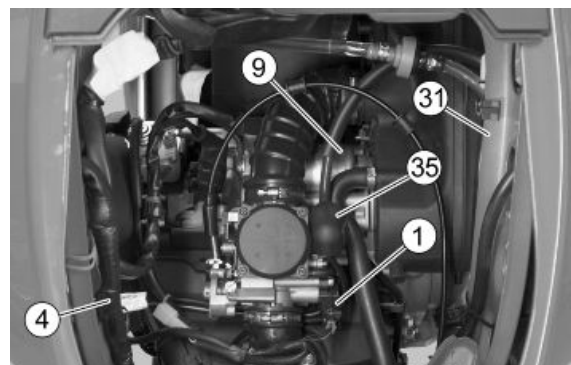

5 - Voltage regulator: remove the front central cover to reach it.

- Generated current value, with lights on and engine at high revs:

Electric characteristic

Generated current value

> 8A

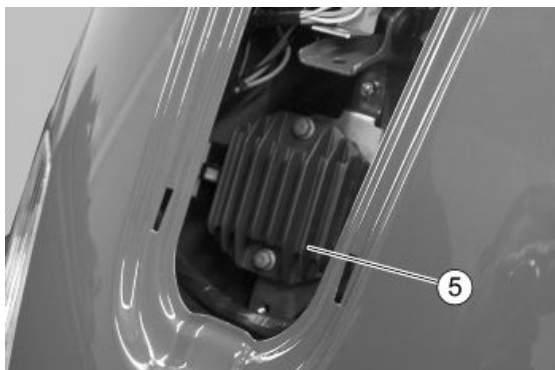

36 - Temperature sensor remove the front central cover to reach it.

- Temperature sensor resistance value:

Electric characteristic

Resistance value (at 25° C)

10KΩ ± 2%

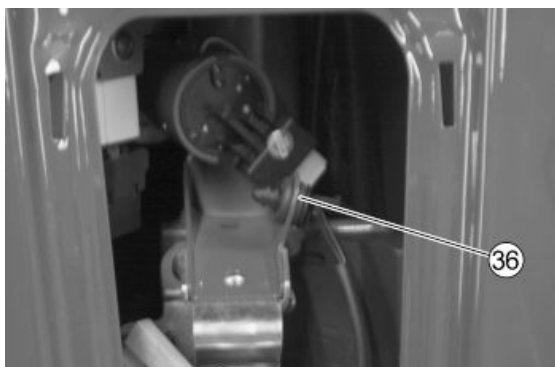

2 / 7 / 16 / 29 - Electronic ignition device / Auxiliary fuses / Light remote control / Horn: remove the front central cover to reach it.

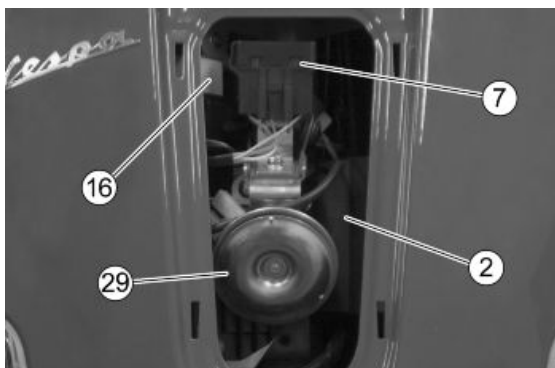

6 / 8 - Main fuses / 12V 10Ah Battery: remove the battery cover to reach it.

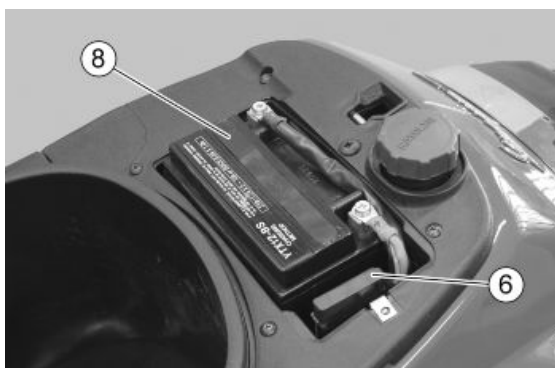

10 - Start-up remote control switch: remove the battery to reach it.

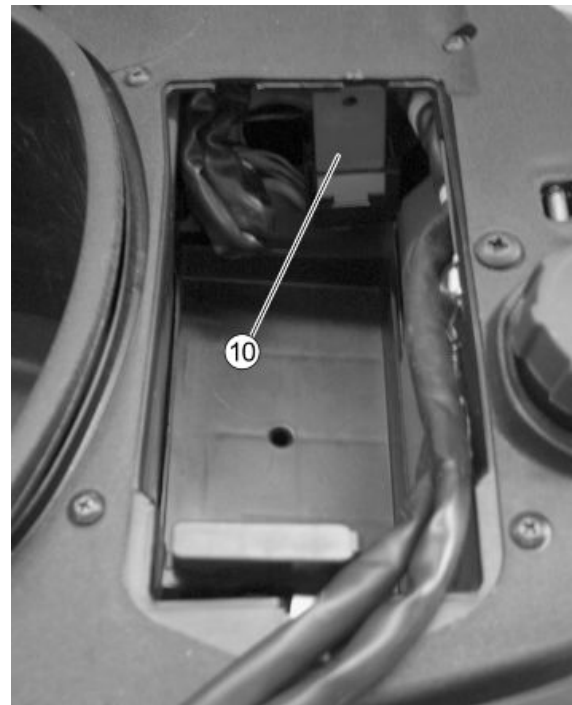

26 - Fuel level transmitter: remove the fuel tank to reach it.

- Fuel level transmitter resistance value:

Electric characteristic

Resistance value when the tank is full

$< = 7\Omega$

Resistance value when the tank is half-full

$38\ \Omega \pm 4\ \Omega$

Resistance value when the tank is empty

$90\ \Omega +13\ \Omega -3\ \Omega$

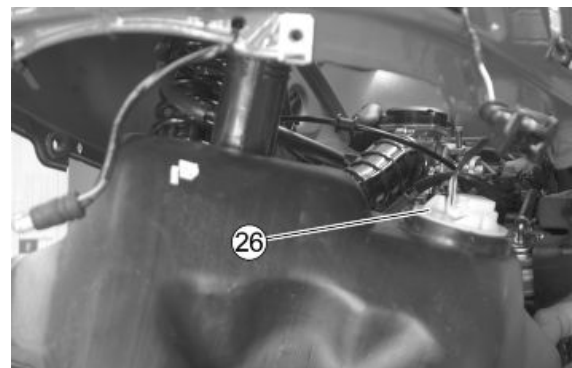

32- Electric pump control device: remove the helmet compartment to reach it.

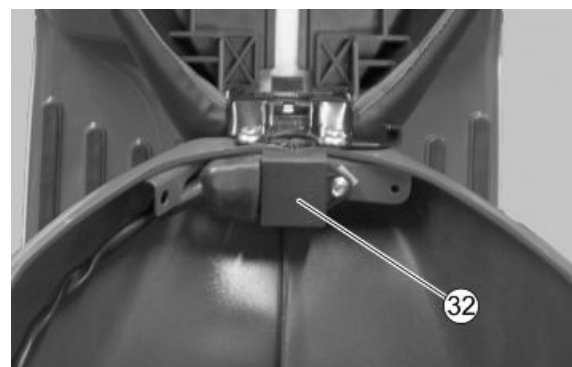

33 - Spark plug: remove the helmet compartment to reach it.

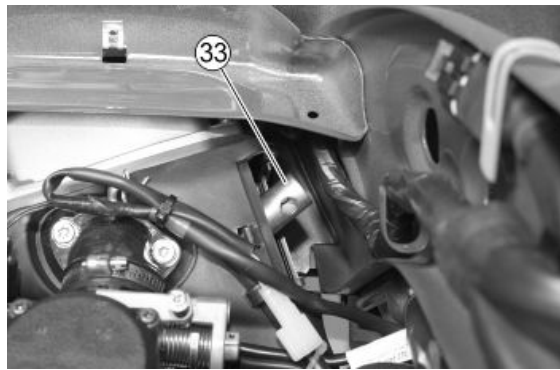

34 - HV coil: remove the inspection door from the central tunnel to reach it.

- HV coil resistance values:

Electric characteristic

High voltage coil primary resistance value

High voltage coil primary resistance value: $0.4 \div 0.5$ Ohm

High voltage coil secondary resistance value

High voltage coil secondary resistance value: $\sim 3000 \pm 300$ Ohm



Conceptual diagrams

Ignition

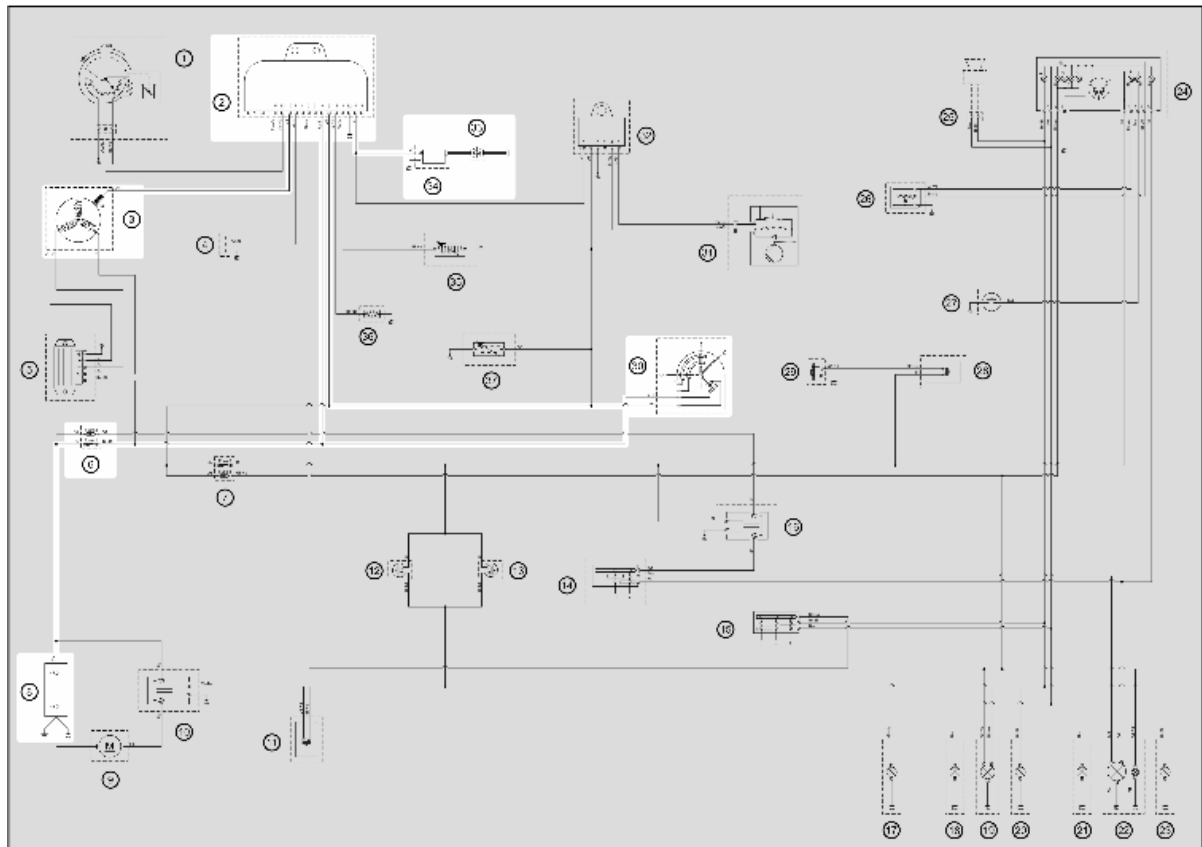
**KEY**

- 2. Electronic ignition device
- 3. Magneto flywheel - Pick-up
- 6. Main fuses
- 8. 12V-10Ah Battery
- 30. Key switch
- 33. Spark plug
- 34. HV coil

Headlights and automatic starter section

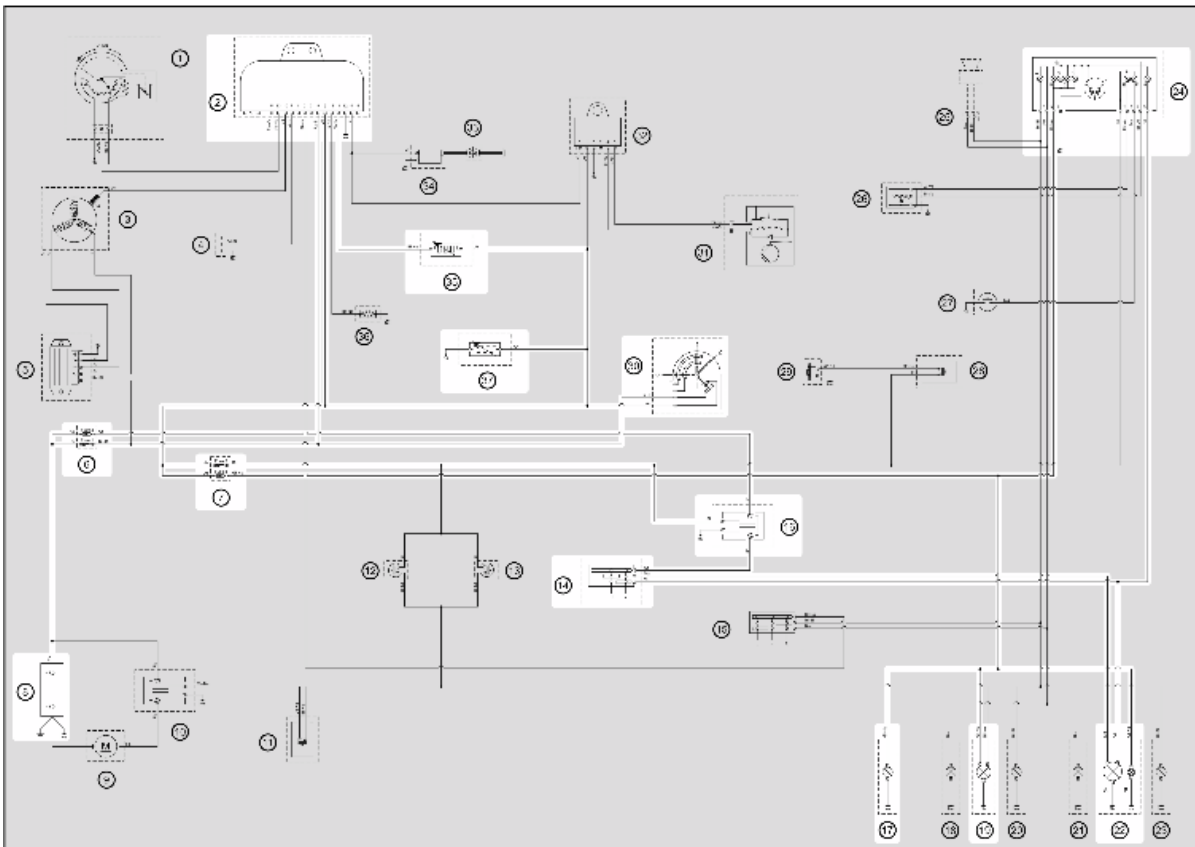

KEY

- 2. Electronic ignition device
- 6. Main fuses
- 7. Auxiliary fuses
- 8. 12V-10Ah Battery
- 14. Light switch
- 16. Light remote control
- 17. License plate light bulb
- 19. Tail light and rear stop light bulb
- 22. Headlight
- A. Low-/high-beam twin filament bulb
- B. Front tail light bulb
- 24. Instrument panel
- B. Headlight warning light
- C. Instrument panel lighting bulbs
- G. High-beam warning light
- 30. Key switch
- 35. Automatic starter

37. Carburettor heater

Battery recharge and starting

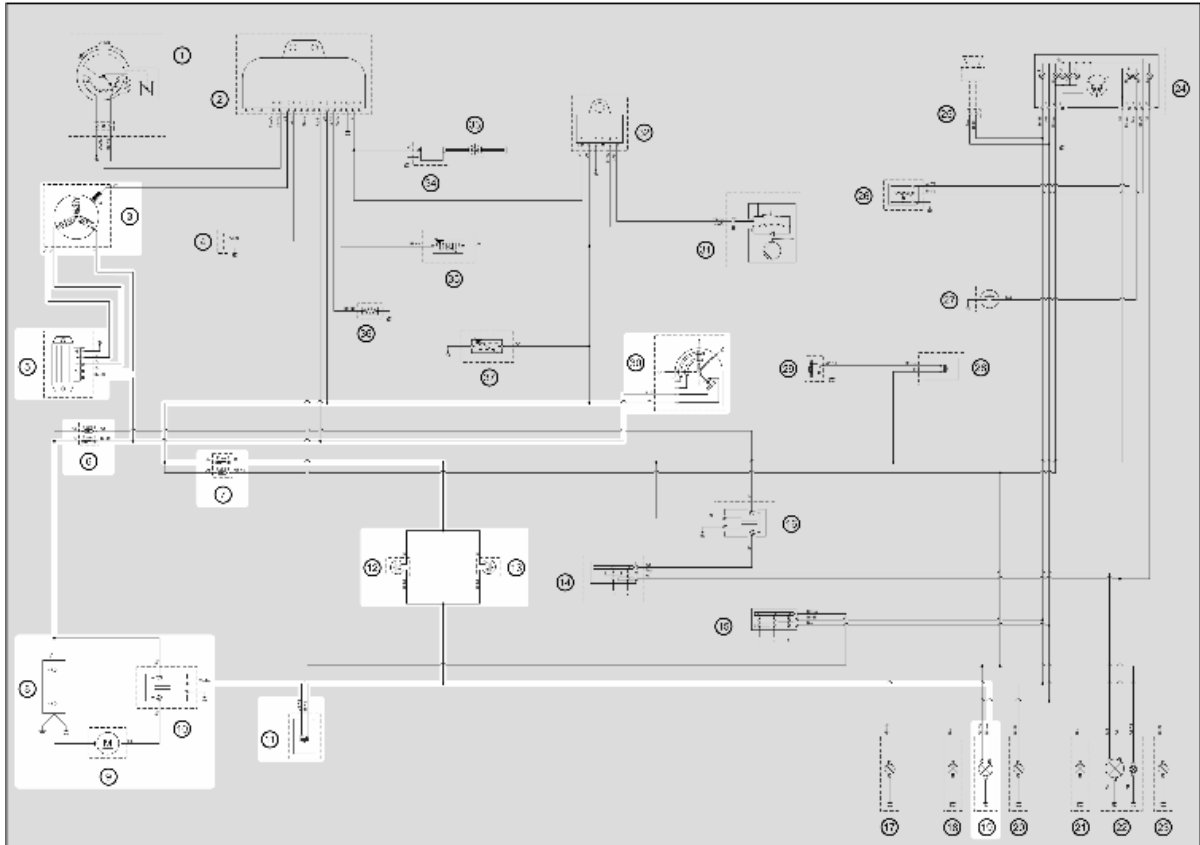

KEY

- 3. Magneto flywheel - Pick-up
- 5. Voltage regulator
- 6. Main fuses
- 7. Auxiliary fuses
- 8. 12V-10Ah Battery
- 9. Starter motor
- 10. Start-up remote control switch
- 11. Starter button
- 12. Stop button on rear brake
- 13. Stop button on front brake
- 19. Tail light and rear stop light bulb
- 30. Key switch

Level indicators and enable signals section

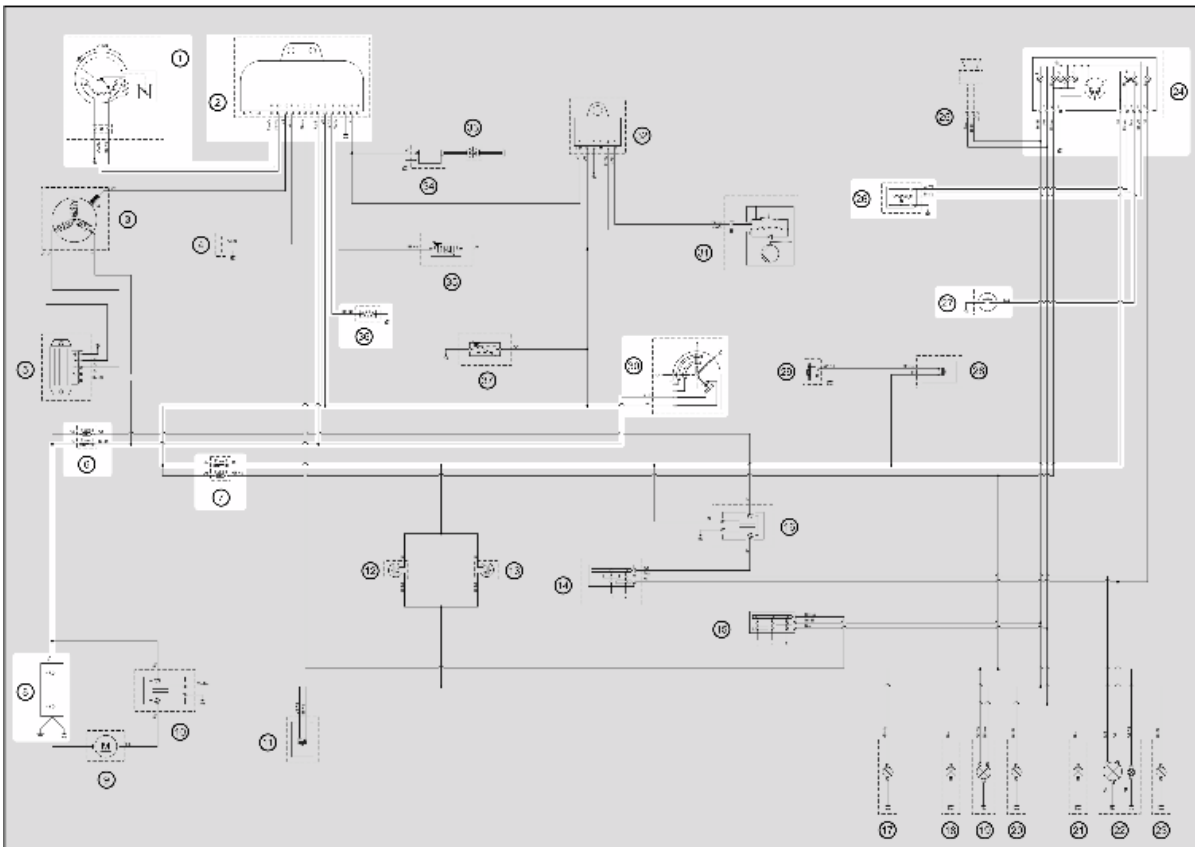

KEY

- 1. Throttle body position
- 2. Electronic ignition device
- 6. Main fuses
- 7. Auxiliary fuses
- 8. 12V-10Ah Battery
- 24. Instrument panel
- D. Fuel gauge
- E. Low fuel warning light
- F. Oil warning light
- 26. Fuel level transmitter
- 27. Engine oil pressure sensor
- 30. Key switch
- 36. Temperature sensor

Devices and accessories

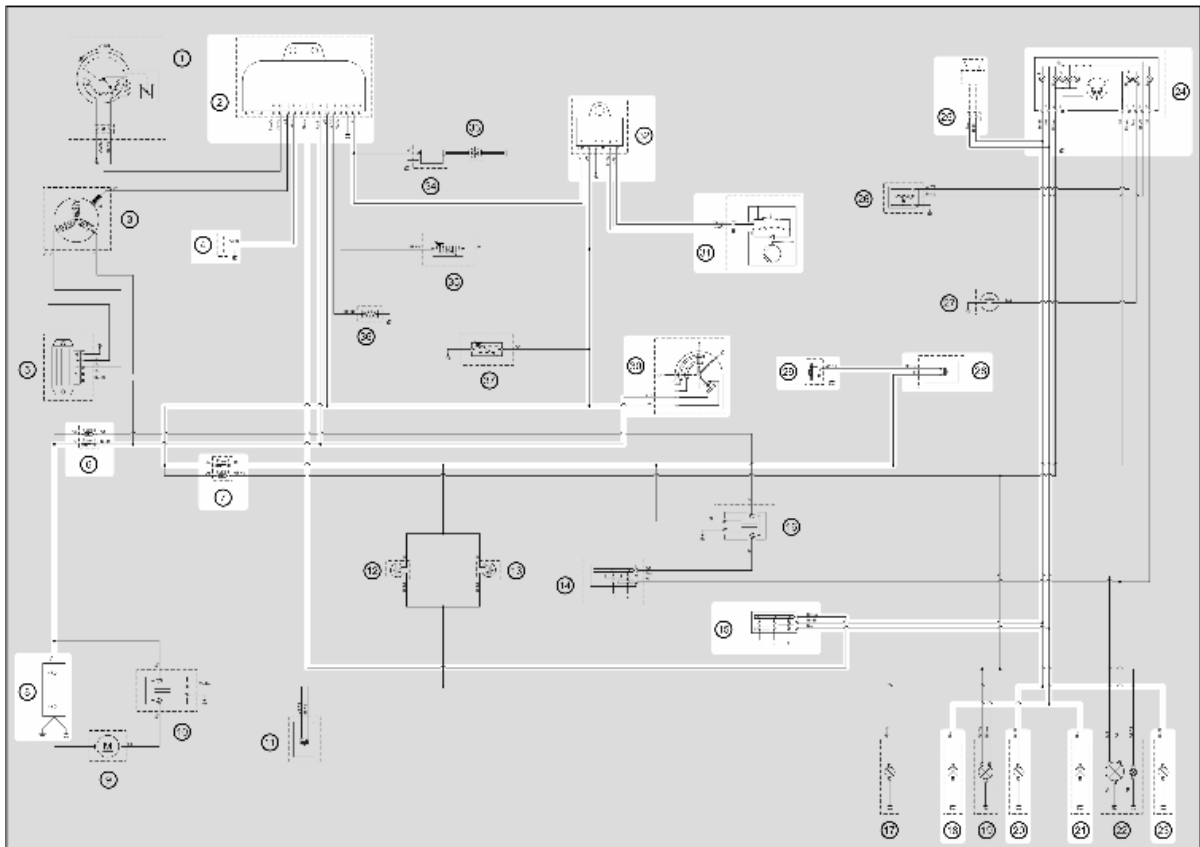
**KEY**

- 2.** Electronic ignition device
- 4.** Diagnostics socket
- 6.** Main fuses
- 7.** Auxiliary fuses
- 8.** 12V-10Ah Battery
- 15.** Turn indicator switch
- 18.** Rear left turn indicator bulb
- 20.** Rear right turn indicator bulb
- 21.** Front left turn indicator bulb
- 23.** Front right turn indicator bulb
- 24.** Instrument panel
- A.** Turn indicator warning light
- 25.** Turn indicators sound alarm wiring
- 28.** Horn button
- 29.** Horn
- 30.** Key switch
- 31.** Fuel pump

32. Fuel electric pump control device

Checks and inspections

Ignition circuit

All the control operations of the system that entail disconnecting cables (to check connections and the devices making up the ignition circuit) **must be done with the engine off**: if this is not done, the controls might be irretrievably damaged.

The battery provides the basic power supply. The system is adjusted so that the start-up system immediately detects an eventual battery voltage drop, and this is practically irrelevant for the ignition system.

The Pick-Up is connected to the control unit by a single cable; therefore, the control unit is connected to the Pick-Up by the chassis and the engine ground lead.

To avoid disturbances in the ignition system during start-up, it is very important that the engine-chassis ground connection bonding is efficient.

The electronic ignition system is fed by direct current and consists of:

- an electronic control unit
- an HV coil

Control unit supply checks

- Disconnect the control unit connector and check if:
 - There is battery voltage between terminal 8 (Red/Blue) and the ground lead.
 - There is battery voltage between the terminal 8 (Red/Blue) and the terminal 12 (Black) as shown in the figure

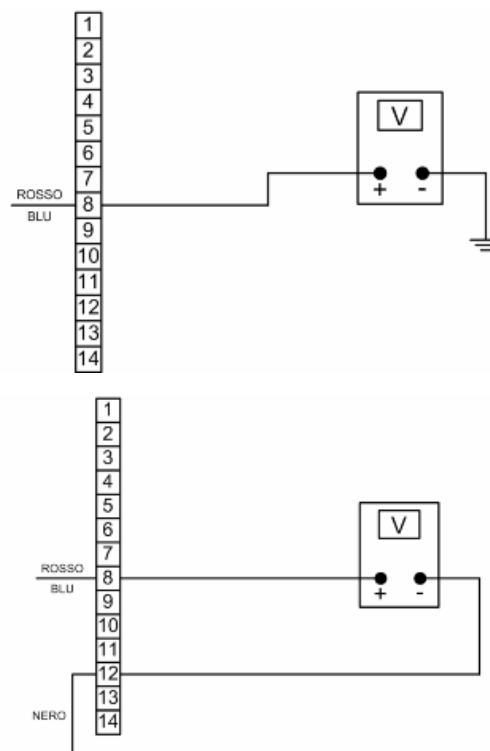

- there is battery voltage between terminals 9 and 12 with the key switch in «ON».

If no faults are found, replace the control unit.

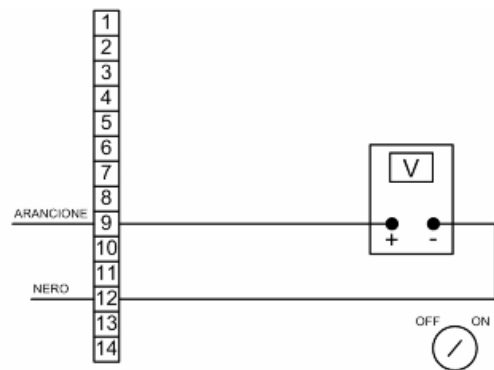

No spark plug

Once the lack of power to the spark plug has been detected, proceed as follows:

- Check the Pick-Up.

Disconnect the control unit connector and check that the cable between terminal No. 10 (Green) and terminal No. 12 (Black) is not interrupted.

The check includes the Pick-Up and its power line.

If a break in the circuit is found, check again the flywheel and the engine earth connectors. If non-conforming values are measured, replace the Pick-Up; otherwise, repair the cable harness.

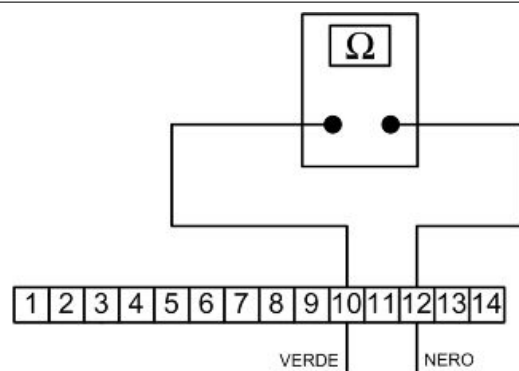

Electric characteristic

Pick-up resistance value

Pick-up resistance value: 105 ÷ 124 Ohm

- HV primary coil check

Disconnect the control unit connector and check that the cable between terminal No. 4 (violet) and terminal No. 12 (black) is not interrupted (see figure).

If non-conforming values are measured, check again the HV coil primary directly on the positive and negative terminals.

If the values are correct, repair the cable harness or reset the connections; otherwise, replace the HV coil

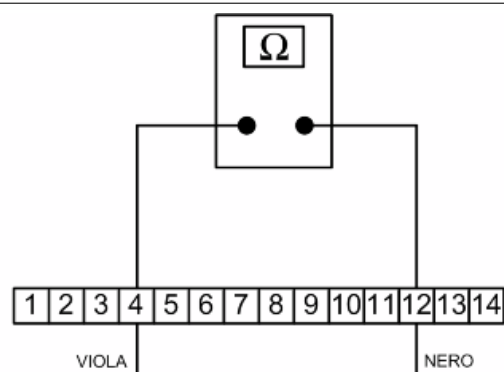

Electric characteristic

High voltage coil primary resistance value

High voltage coil primary resistance value: $0.4 \div 0.5$ Ohm

- HV coil secondary check

Disconnect the spark plug cap from the HV cable and measure the resistance between the HV cable terminal and the HV coil negative terminal (see figure).

If non-conforming values are measured, replace the HV coil. To carry out a more complete diagnosis, check the peak voltage with the multimeter adaptor.

Specific tooling

020409Y Multimeter adaptor - Peak voltage detection

Electric characteristic

High voltage coil secondary resistance value

High voltage coil secondary resistance value: $\sim 3000 \pm 300$ Ohm

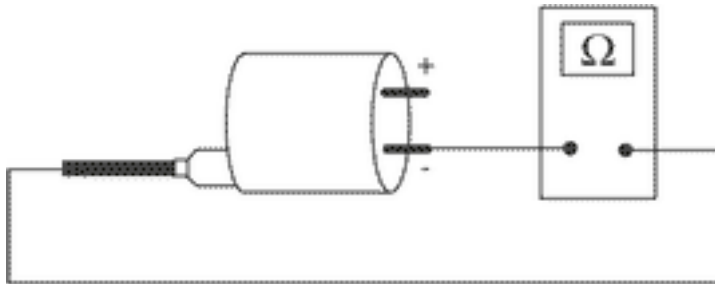

- Pick-Up

Disconnect the control unit connector and connect the positive wire to connector No. 10 and the negative wire to connector No. 12 (see figure).

Use the start-up system to run the engine and measure the voltage produced by the Pick-Up.

Replace Pick-Up if non-conforming values are measured.

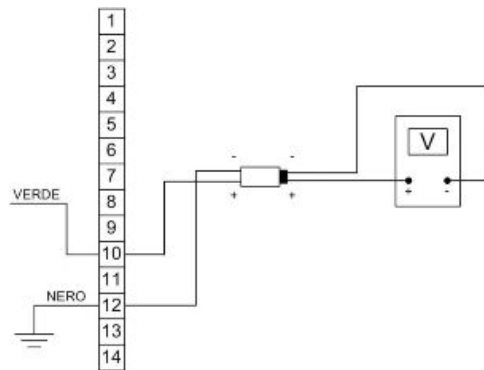

N.B.

THE MULTIMETER MUST BE SELECTED TO DETECT CONTINUOUS VOLTAGE.

Electric characteristic

Pick-Up voltage value

Pick-Up voltage value: > 2 Volt

- H.V. coil

With the control unit and HV coil connected to the circuit, measure the voltage of the coil primary during the start-up test with the voltage peak adaptor and connect the positive terminal to the earth one and the negative to the coil positive connector. If non-conforming values are measured, replace the control unit.

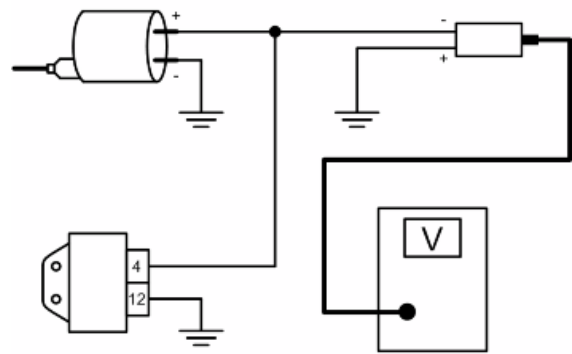

THE POSITIVE TERMINAL OF THE HV COIL PRIMARY IS BLACK.

Electric characteristic**High voltage coil voltage value**

High voltage coil voltage value: > 100 Volt

Battery recharge circuit

The recharge system is provided with a three phase alternator with permanent flywheel.

The alternator is directly connected to the voltage regulator.

In turn, the latter is directly connected to earth and to the battery positive passing through the 15A safety fuse.

This system therefore requires no connection to the key switch.

The three- phase generator provides good recharge power and at low revs a good compromise is achieved between generated power and idle stability.

For this reason, it is very important that the idle speed is adjusted as prescribed.

Specific tooling

020333Y Single battery charger

020334Y Multiple battery charger

Stator check

Disconnect the connector from the voltage regulator and check there is continuity between any yellow cable and the other two cables.

Electric characteristic**Ohm value:**

0.7 ÷ 0.9 Ohm

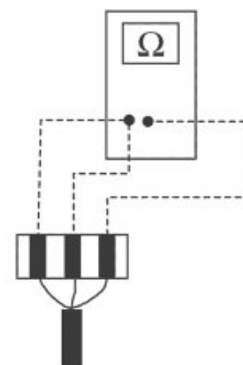

Also check that all yellow cables are insulated from the ground connection.

If non-conforming values are detected, repeat the checks directly to the stator. In case of further repetitions of incorrect values replace the stator or repair the wiring.

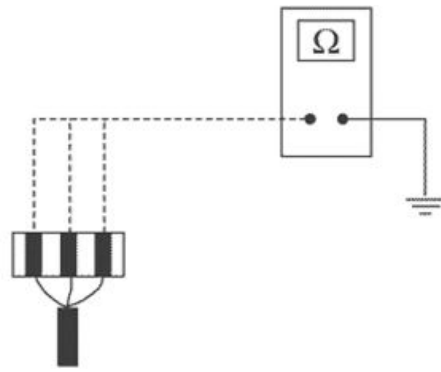

Voltage regulator check

With a perfectly charged battery and lights off, measure voltage at the battery poles with a high running engine.

The voltage should not exceed 15.2 Volt.

In case higher voltages are detected, replace the regulator.

In case of voltage values lower than 14 Volt, check the stator and the corresponding cable harness.

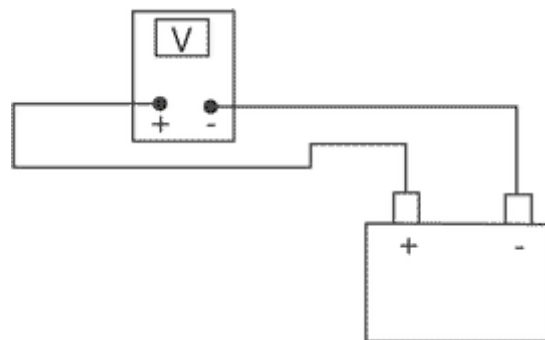

Recharge system voltage check

Connect an ammeter induction clamp to the voltage regulator positive terminal, measure the battery voltage and turning on the vehicles lights with engine off, wait for the voltage to set at about 12 V. Start the engine and measure the current generated by the system with lights on and a high running engine.

In case the generated current value is lower than 8A, repeat the test using a new regulator and/stator alternatively.

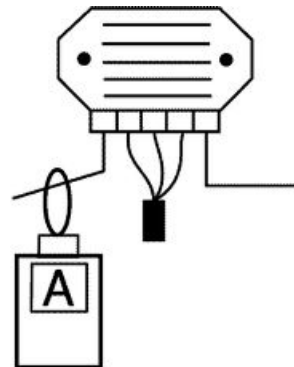

Choke Inspection

Refer to the engine section to check the resistance and operating conditions of the component. As regards voltage supply, keep the connector connected to the system and check that the two terminals receive battery voltage when **the engine is on** (see figure).

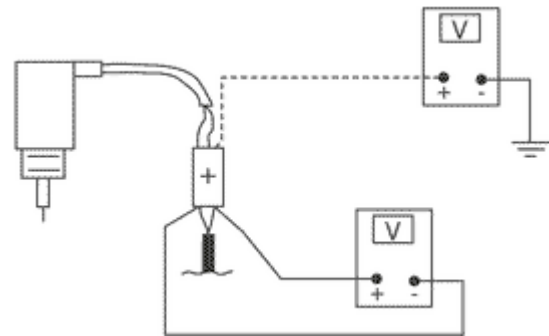

If no voltage is detected, connect the multimeter negative terminal to the ground lead and the positive terminal to the automatic starter orange cable; with the key switch set to "ON" check whether there is battery voltage; if there is no voltage, check the wiring connections to the key switch.

If there is voltage, check again the ignition control unit connector.

After disconnecting the starter, start up the engine and keep it at idle speed; then check if there is voltage by connecting the multimeter positive probe to terminal 9 (Orange), and the negative one to terminal 11 (White/Black) (see figure).

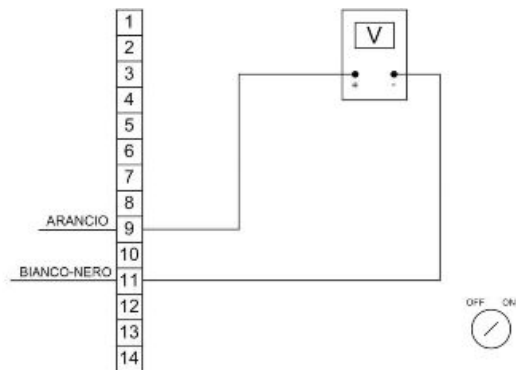

Replace the control unit if there is no voltage; otherwise, check the wiring connections between the starter and the control unit.

Turn signals system check

- If the turn indicators do not work, proceed as follows:
- Disconnect the electronic control unit connector and check that there is voltage between terminal 9 (Orange) and the earth connection with the key switch set to "ON".
- Check that the same happens between terminal 9 (Orange) and terminal 12 (Black).

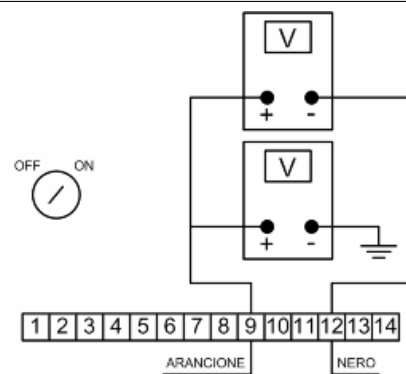

If no voltage is detected, check the cable harness and the connections; otherwise, proceed as follows:

- Jump terminals 2 (Black/Blue) and 9 (Orange), see figure. Turn the turn indicator switch alternately to the left and to the right with the key switch in "ON" and check if the lights turn on.

If they do, replace the control unit because it is faulty.

If they do not turn on, check the control unit-turn indicator switch connection cable harness; then, repeat the test.

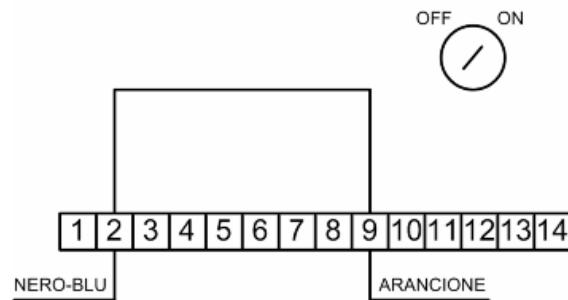

Sealed battery

If the vehicle is provided with a sealed battery, the only maintenance required is the check of its charge and recharging, if necessary.

These operations should be carried out before delivering the vehicle, and on a six-month basis while the vehicle is stored in open circuit.

Besides, upon pre-delivery it is therefore necessary to check the battery charge and recharge it, if required, before storing the vehicle and, afterwards, every six months.

INSTRUCTIONS FOR THE RENEWAL RECHARGE AFTER OPEN-CIRCUIT STORAGE

1) Voltage check up

Before installing the battery on the vehicle, check the open circuit voltage with a regular tester.

- If voltage exceeds 12.60 V, the battery can be installed without any renewal recharge.
- If voltage is below 12.60 V, a renewal recharge is required as explained in 2).

2) Constant voltage battery charge mode

- Constant voltage charge equal to 14.40 ÷ 14.70V
- Initial charge voltage equal to 0.3 ÷ 0.5 for Nominal capacity
- Charge time:

10 to 12 h recommended

Minimum 6 h

Maximum 24 h

3) Constant current battery charge mode

- Charge current equal to 1/10 of the battery rated capacity
- Charge time: Maximum 5 h

Dry-charge battery

WARNING

- Battery electrolyte is toxic and it may cause serious burns. It contains sulphuric acid. Avoid contact with eyes, skin and clothing. In case of contact with eyes or skin, flush abundantly with water for about 15 minutes and seek immediate medical attention.

In the event of accidental ingestion of the fluid, immediately drink large quantities of water or milk. Follow with milk of magnesia, beaten egg or vegetable oil. Seek immediate medical attention

Batteries produce explosive gases; keep clear of free flames, sparks or cigarettes; ventilate the area when recharging the battery indoors.

Always protect your eyes when working close to batteries.

Keep out of the reach of children.

Commissioning dry-charged batteries :

- 1) - Remove the short closed tube and the caps, then pour sulphuric acid into the cells using the type specified for batteries with a specific gravity of 1.26, corresponding to 30 Be at a minimum temperature of 15°C until the upper level is reached.
- 2) - Leave to rest for at least 2 hours; then, restore the level with sulphuric acid.
- 3) - Within the following 24 hours, recharge using the specific battery charger (single) or (multiple) at a density of about 1/10 of the battery nominal capacity until fully charged; check that the acid density is about 27, corresponding to 31 Be, and that these values are stabilised.
- 4) - Once the charge is over, level the acid (by adding **distilled water**). Close and clean carefully.
- 5) Once the above operations have been performed, install the battery on the vehicle ensuring that it is wired up properly.

1 Hold the vertical tube

2 Look at the level

3 The float must be freed

WARNING

- ONCE THE BATTERY HAS BEEN INSTALLED IN THE VEHICLE IT IS NECESSARY TO REPLACE THE SHORT TUBE (WITH CLOSED END) NEAR THE + POSITIVE TERMINAL WITH THE CORRESPONDING LONG TUBE (WITH OPEN END), THAT YOU FIND FITTED TO THE VEHICLE, TO ENSURE THAT THE GASES THAT FORM CAN ESCAPE PROPERLY.

Specific tooling

020333Y Single battery charger

020334Y Multiple battery charger

Battery maintenance

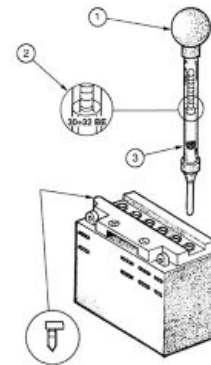

The battery is an electrical device which requires careful monitoring and careful maintenance. The maintenance rules are:

1) Electrolyte level check

The electrolyte level must be checked frequently and must reach the upper level. Only use distilled water, to restore this level. If it is necessary to add water too frequently, check the vehicle electrical system: the battery works overcharged and is subject to quick wear.

2) Load status check

After restoring the electrolyte level, check its density using an appropriate densitometer (see the figure). When the battery is charged, you should detect a density of 30 to 32 Bé corresponding to a specific weight of 1.26 to 1.28 at a temperature of no lower than 15° C.

A density reading of less than 20° Bé indicates that the battery is completely flat and it must therefore be recharged.

If the scooter is not used for a given time (1 month or more) it will be necessary to periodically recharge the battery.

The battery runs down completely in the course of three months. If it is necessary to refit the battery in the vehicle, be careful not to reverse the connections, remembering that the ground wire (**black**) marked (-) must be connected to the **-negative** clamp while the other two **red** wires marked (+) must be connected to the clamp marked with the **+positive** sign.

3) Recharging the battery

Remove the battery from the vehicle removing the negative clamp first.

Regular bench charging must be carried out with the specific battery charger, (single) or (multiple), setting the battery charger selector to the type of battery to be recharged. Connections to the power supply source must be implemented by connecting the corresponding poles (+ to+ and - to -).

4) Battery cleaning

The battery should always be kept clean, especially on its top side, and the terminals should be coated with Vaseline.

WARNING

BEFORE RECHARGING THE BATTERY, REMOVE THE PLUGS OF EACH CELL. KEEP SPARKS AND NAKED FLAMES AWAY FROM THE BATTERY WHILE RECHARGING.

CAUTION

NEVER USE FUSES WITH A CAPACITY HIGHER THAN THE RECOMMENDED CAPACITY. USING A FUSE OF UNSUITABLE RATING MAY SERIOUSLY DAMAGE THE VEHICLE OR EVEN CAUSE A FIRE.

CAUTION

ORDINARY AND DRINKING WATER CONTAINS MINERAL SALTS THAT ARE HARMFUL FOR THE BATTERY. FOR THIS REASON, YOU MUST ONLY USE DISTILLED WATER.

CAUTION

TO ENSURE MAXIMUM PERFORMANCE THE BATTERY MUST BE CHARGED BEFORE USE. INADEQUATE CHARGING OF THE BATTERY WITH A LOW ELECTROLYTE LEVEL BEFORE IT IS FIRST USED SHORTENS THE LIFE OF THE BATTERY.

Specific tooling

020333Y Single battery charger

020334Y Multiple battery charger

Pump electrics check

If the engine does not work properly, the electric pump control unit may not work properly either. In this case:

- Remove the helmet compartment so as to reach the electric fuel pump.
- Disconnect the fuel supply connector from the pump.
- Check that the fuel supply to the pump is adequate according to the data on the table.

**PUMP SUPPLY**

Specification	Desc./Quantity
Key set to «KEY ON»	Supply to the pump for 13 seconds
Engine revs from 0 to 200 rpm	Always «OFF»
Engine revs from 200 to 1200 rpm	Always «ON»
Engine revs from 1200 to 2000 rpm	0.2 seconds «ON» 9 seconds «OFF»
Engine rpm] 2000 rpm	Always «ON»

If the pump does not work:

- Disconnect the fuel supply connector from the pump.
- Make sure there is battery voltage at the connector ends.
- If there is no voltage, check the continuity of the cable harness and replace it if damaged.
- If the cable harness is intact, check that the fuel pump works properly by applying a 12 V voltage.

Replace the pump if damaged.

- If the pump works properly, replace the control unit.

Characteristic**Pump capacity**

350 ml/min minimum (at 4.4 kPa)

Connectors

FUEL PUMP CONTROL DEVICE CONNECTOR

1. Live power supply (Orange)
2. Not connected
3. Fuel pump negative (White-Black)
4. Fuel pump positive (Blue-Black)
5. Ground (Black)
6. Engine revs (Purple)

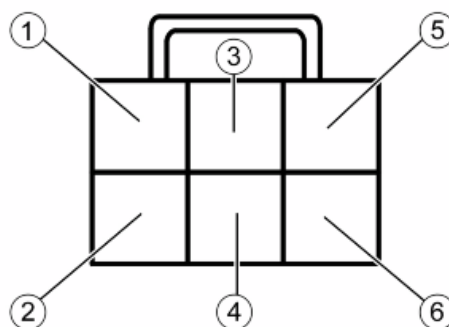

VOLTAGE REGULATOR CONNECTOR

1. Battery positive (Red-Blue)
2. Magneto flywheel (Yellow)
3. Not connected
4. Magneto flywheel (Yellow)
5. Ground (Black)
6. Magneto flywheel (Yellow)

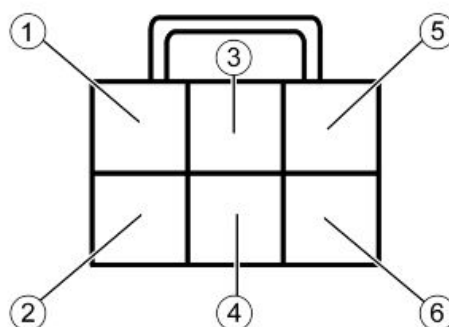

DIAGNOSIS CONNECTOR

1. Not connected
2. Ground (Black)
3. CDI control unit (Purple-White)

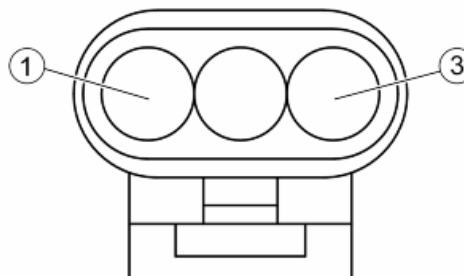

TPS SENSOR CONNECTOR

1. TPS signal (Green-Black)
2. Ground (Black)
3. Control unit positive (Red-Green)

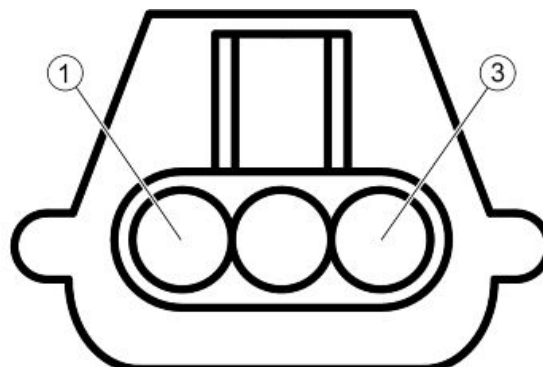

STARTER CONNECTOR

1. Live power supply (Orange)
2. Control unit negative (White-Black)

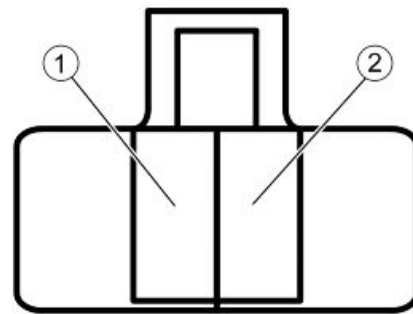

MAGNETO FLYWHEEL CONNECTOR

1. Engine oil pressure sensor (Brown)
2. Voltage regulator (Yellow)
3. Pick-up (Green)
4. Voltage regulator (Yellow)
5. Not connected
6. Voltage regulator (Yellow)

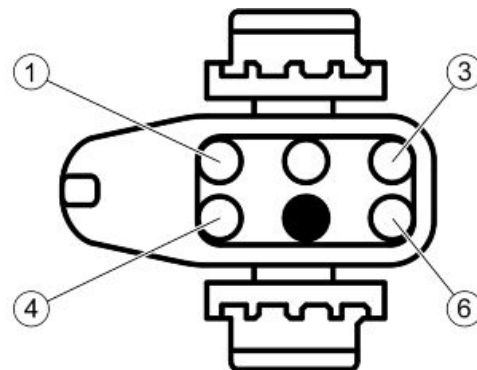

INSTRUMENT PANEL CONNECTOR "A"

1. Right turn indicator warning light (White-Blue)
2. Left turn indicator warning light (Pink)
3. Panel lighting and headlight warning light (Yellow-Black)
4. Ground (Black)

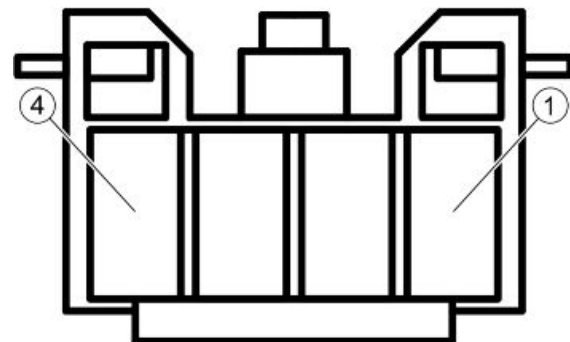

INSTRUMENT PANEL CONNECTOR "B"

1. Power permanent supply (White)
2. Low fuel warning light (Yellow-Green)
3. Oil warning light (Brown)
4. Fuel level indicator (White-Green)
5. High-beam warning light (Purple)

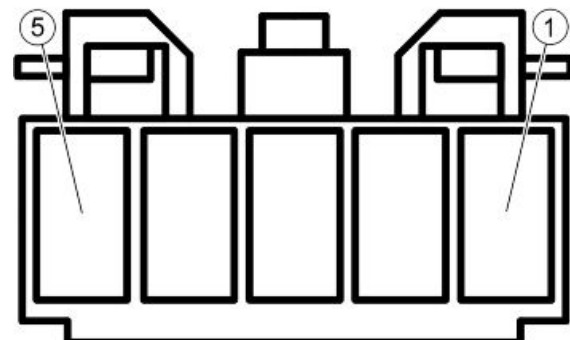

CDI CONTROL UNIT CONNECTOR

1. Not connected
2. Turn indicator switch (Blue-Black)
3. Not connected
4. HV coil (Purple)
5. TPS positive (Red-Green)
6. Not connected
7. Diagnosis connector (Purple-White)
8. Battery powered (Red-Blue)
9. Live power supply (Orange)
10. Pick-up (Green)
11. Automatic starter negative (White-Black)
12. Ground (Black)
13. TPS signal (Green-Black)
14. Temperature sensor (Red-Black)

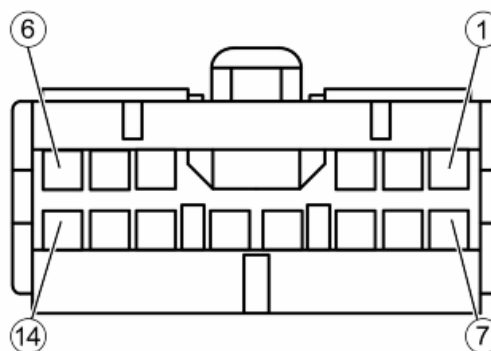
**TURN INDICATORS SOUND ALARM CONN-
ECTOR**

1. Left turn indicator warning light (Pink)
2. Right turn indicator warning light (White-Blue)

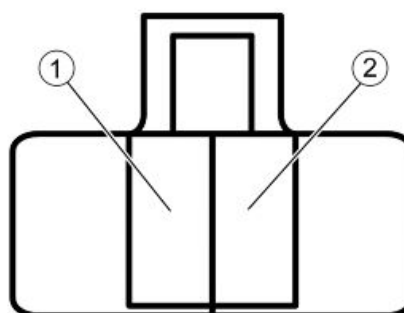
**FUEL PUMP CONNECTOR**

1. Pump negative (White-Black)
2. Pump positive (Blue-Black)

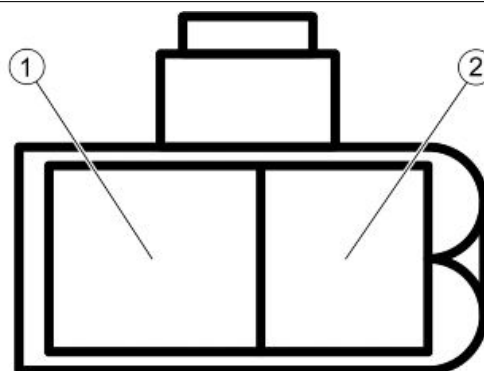

INDEX OF TOPICS

ENGINE FROM VEHICLE

ENG VE

Exhaust assy. Removal

- Remove the 2 fixing nuts from the manifold to the head



- Unscrew the 2 screws fixing the muffler to the housing; then remove the whole muffler paying attention to the interference between its supporting bracket and the cooling cover.

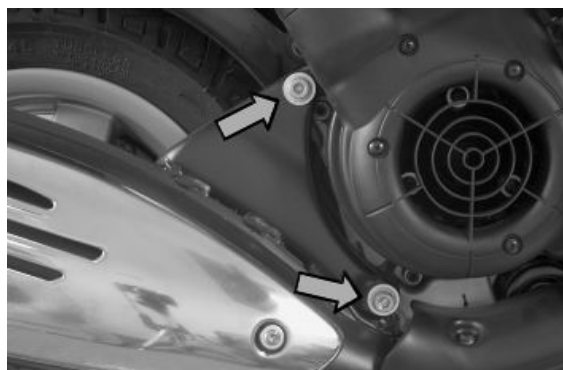

Removal of the engine from the vehicle

- Remove the left and right side fairings
- Remove the helmet compartment
- Remove the full muffler assembly.
- Remove the 3 rear brake transmission fixing screws indicated in the photograph
- Disconnect the rear brake transmission unscrewing the set screw



- Disconnect the belt cooling tube and the swinging arm retaining spring shown in the photograph
- Disconnect the spark plug tube



-
- Remove the throttle control cable from the carburettor, indicated in the photograph

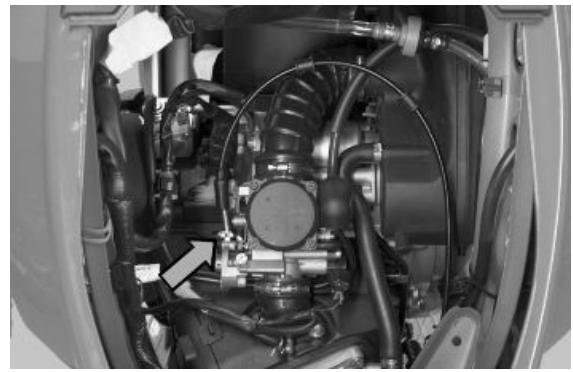

-
- Remove the fuel supply pipe from the carburettor



-
- Remove the flywheel wiring connector, the earth terminal and the starter motor positive cable indicated in the figure



-
- Remove the protection sheath indicated in the figure and disconnect the automatic starter and TPS connectors.



- Unscrew the engine pin-swinging arm nut on the right-hand side of the vehicle and slide off the pin on the left hand side
- Support the vehicle adequately (with a jack) and remove the shock absorber lower clamping. The engine is now free.

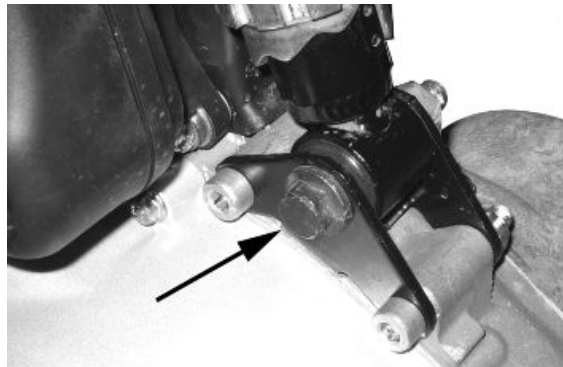
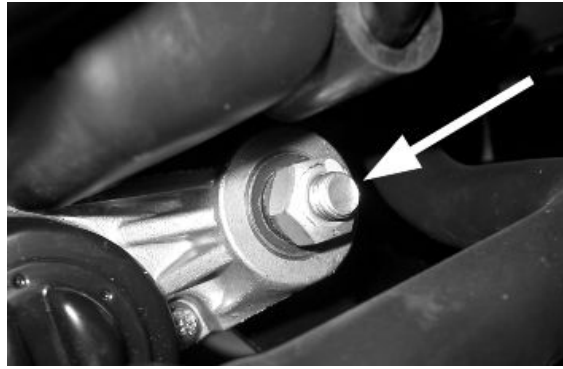

INDEX OF TOPICS

ENGINE

ENG

This section describes the operations to be carried out on the engine and the tools to be used.

Automatic transmission

Transmission cover

- To remove the transmission cover it is necessary to remove the rear plastic cover first by inserting a screwdriver in the corresponding slotted holes.

Using the clutch bell lock wrench, remove the driven pulley axle locking nut and recover the washer.

- Remove the cap/dipstick from the engine oil filling hole.

- Remove the 10 screws and the earth cable fastened under one of them.

- Remove the transmission cover. If this operation is performed directly on the vehicle, it is necessary to remove the cooling air coupling and the three air filter housing retainers.

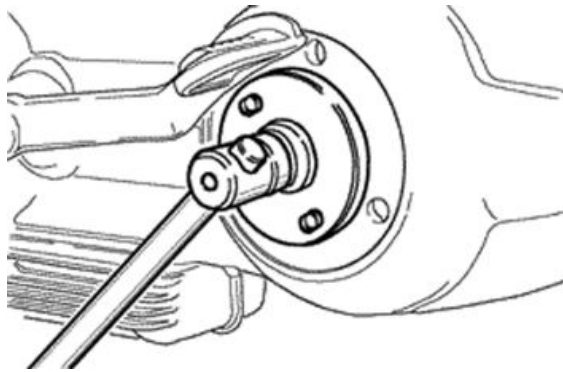

Specific tooling

020423Y driven pulley lock wrench

Kickstart

- Check the following for wear: toothed section, toothed section shaft, cover seat bushing, pinion shaft and its seating in the crankcase and the return spring.

- Remove the damaged components.

- Lubricate the spring with the recommended grease.

- Remove the toothed sector and load the spring with an appropriate tool.

- Refit the washer, the seeger ring and the Kick-start lever.

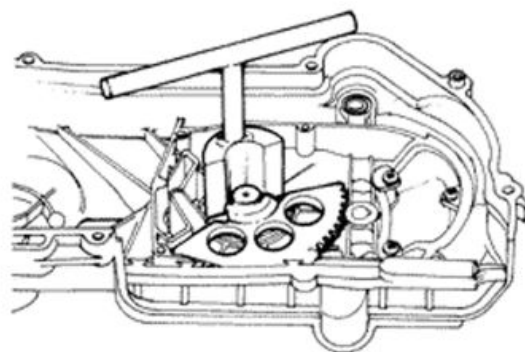

Specific tooling

020432Y Tool to fit the start-up sector spring

Recommended products

AGIP GREASE MU3 Grease for odometer transmission gear case

Soap-based lithium grease with NLGI 3; ISO-L-XBCHA3, DIN K3K-20

- Operating the starter lever, load the spring and introduce the pinion in its seat.
- Refit the intake throat with the 3 screws and the Kick-starter cover with the 4 screws. Tighten the screws to the prescribed torque.

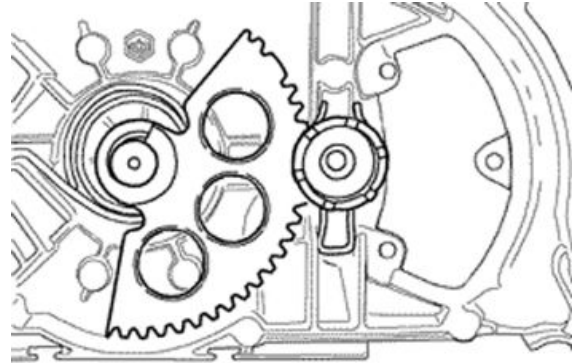

- Remove the start-up pinion pushing the starter lever.
- Unscrew the kick starter screw, remove the lever.
- Remove the seeger ring and the washer indicated in the figure.
- Pull out the toothed section.

WARNING

THE SECTION KEEPS THE SPRING SET, BE CAREFUL SO AS NOT TO CAUSE ANY ACCIDENTS

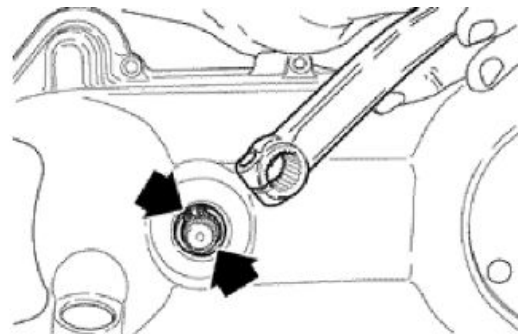

Air duct

- Unscrew the Torx screws fixing the air manifold bulkhead and remove the bulkhead.
- Remove the 3 screws, then take out the manifold as well as the filter.

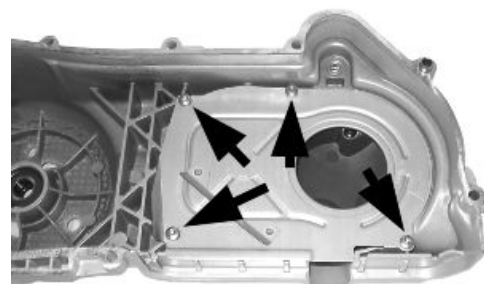

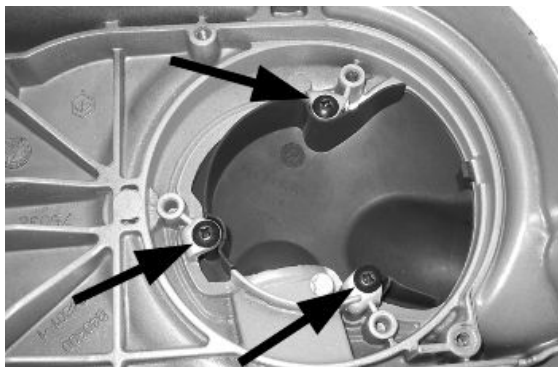

Removing the driven pulley shaft bearing

- Remove the clip from the inside of the cover.
- Use the specific tools to remove the bearing from the crankcase.

CAUTION

USE AN APPROPRIATE REST SURFACE TO AVOID DAMAGING THE COVER PAINT.

Specific tooling

020376Y Adaptor handle

020375Y Adaptor 28 x 30 mm

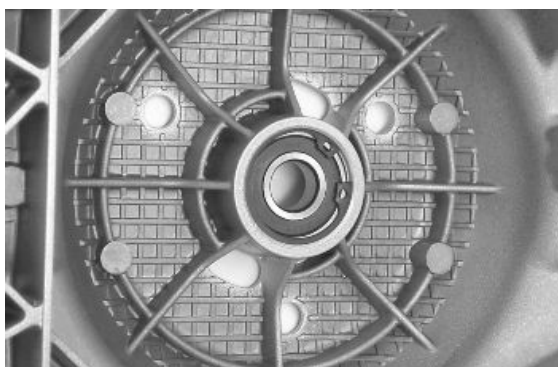

Refitting the driven pulley shaft bearing

- Heat up the crankcase inside with the hot air gun.
- Insert the bearing in its housing, refit the Seeger ring.

N.B.

ALWAYS REPLACE THE BEARING WITH A NEW ONE UPON REFITTING.

Specific tooling

020151Y Air heater

020376Y Adaptor handle

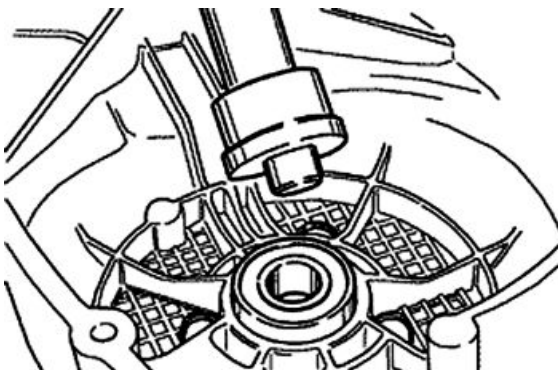

020357Y 32 x 35 mm adaptor

020412Y 15 mm guide

Removing the driven pulley

- Remove the spacer, the clutch bell and the whole driven pulley unit.

N.B.

THE UNIT CAN ALSO BE REMOVED WITH THE DRIVING PULLEY MOUNTED.

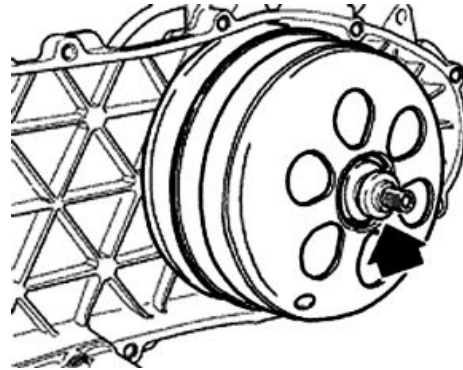

Inspecting the clutch drum

- Check that the clutch bell is not worn or damaged.
- Measure the clutch bell inside diameter.

Characteristic

Max. value clutch bell

Max. value: \varnothing 134.5 mm

Clutch bell standard value

Standard value: \varnothing 134 - 134.2 mm

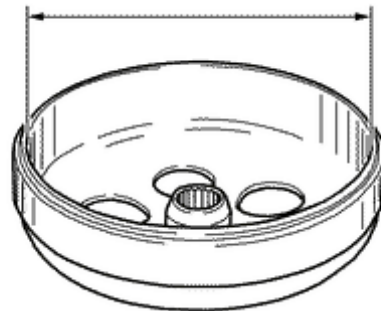

Checking the bell working surface eccentricity

- Install the bell on a driven pulley shaft using 2 bearings (inner diameter 15 and 17 mm).
- Lock with the original spacer and nut.
- Place the bell/shaft assembly on the support to check the crankshaft alignment.



- Using a feeler pin gauge and the magnetic base, measure the bell eccentricity.
- Repeat the measurement in 3 positions (Central, internal, external).
- If faults are found, replace the bell.



Specific tooling

020074Y Support base for checking crankshaft alignment

020335Y Magnetic support for dial gauge

Characteristic

clutch bell inspection: Limit eccentricity.

Admissible limit eccentricity: 0.15 mm

Removing the clutch

- Prepare the locking tool for the driven pulley with the pins half-screwed in the tool set to «C».



- Fit the driven pulley unit in the tool so as the bolt get into the masses clutch support holes. Afterwards make the support screw make contact with a minimum force.

- Using the specific wrench, inserted 46 mm from the side, remove the clutch central locking nut.

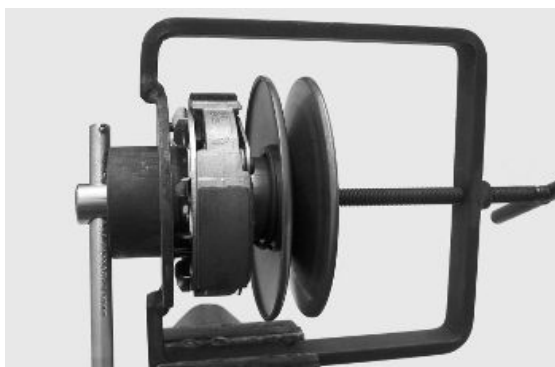

- Separate the driven pulley into its components (clutch with fan and contrast spring with plastic fittings).

CAUTION

THE TOOL MUST BE FIRMLY FIXED IN THE VICE AND THE CENTRAL SCREW MUST NOT BE TIGHTENED WITH EXCESSIVE TORQUE AS THIS MAY DAMAGE THE PULLEY OR DEFORM THE SPECIFIC TOOL.

Specific tooling

020444Y Tool for fitting/ removing the driven pulley clutch

020444Y009 46x55 Wrench

Inspecting the clutch

- Check the thickness of the clutch mass friction material.
- The masses must not show traces of lubricants; otherwise, check the driven pulley unit seals.

N.B.

UPON RUNNING-IN, THE MASSES MUST EXHIBIT A CENTRAL CONTACT SURFACE AND MUST NOT BE DIFFERENT FROM ONE ANOTHER. VARIOUS CONDITIONS CAN CAUSE THE CLUTCH TO TEAR.

CAUTION

DO NOT OPEN THE MASSES USING TOOLS TO PREVENT A VARIATION IN THE RETURN SPRING LOAD.

Characteristic

Check minimum thickness

1 mm



Pin retaining collar

- Remove the collar with the aid of 2 screwdrivers.
- Remove the 3 guide pins and the movable half-pulley.

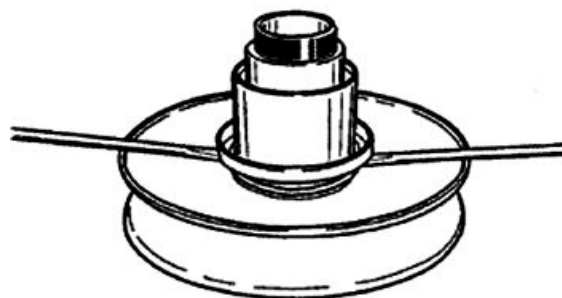

Removing the driven half-pulley bearing

- Remove the retaining ring using two flat blade screwdrivers.
- Using a hammer and pin, knock the ball bearing out as shown in the figure.
- Remove the roller bearing using the specific extractor.

N.B.

REST THE HALF-PULLEY ON A WOOD SURFACE TO AVOID DAMAGING THE THREADED RINGLET OF THE DRIVEN PULLEY UPON REMOVING IT.

Specific tooling

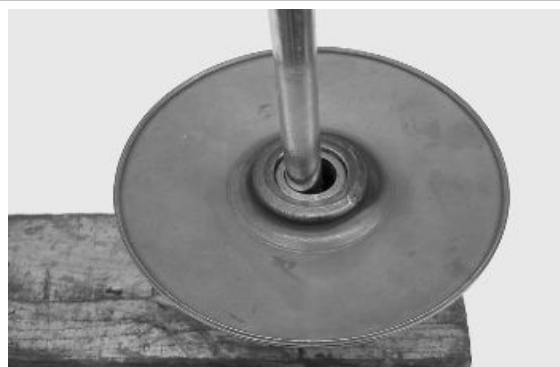

020375Y Adaptor 28 x 30 mm

020376Y Adaptor handle

020439Y 17 mm guide



Inspecting the driven fixed half-pulley

- Measure the external diameter of the pulley bushing.

Characteristic

Minimum diameter permitted

Ø 40.96 mm

Standard diameter

Ø 40.965 mm



Inspecting the driven sliding half-pulley

- Remove the 2 inner sealing rings and the two O-rings.

- Measure the inside diameter of the mobile half-pulley bushing.

Characteristic

Minimum admissible diameter

Ø 41.08 mm

Standard diameter

Ø 41.035 mm



Refitting the driven half-pulley bearing

- Assemble a new roller case using the specific punch, fit the bearing with the label facing outward and insert it completely up to the punch on the half-pulley.

N.B.

REST THE HALF-PULLEY ON A WOOD SURFACE TO AVOID DAMAGING THE THREADED RINGLET OF THE DRIVEN PULLEY UPON REMOVING IT.

Specific tooling

020424Y Driven pulley roller casing fitting punch



- To assemble the new ball bearing insert it completely down in its housing with the specific punch and finally assemble the Seeger ring.

Specific tooling

020375Y Adaptor 28 x 30 mm

020376Y Adaptor handle

020439Y 17 mm guide



Refitting the driven pulley

- Check that the facing surfaces between the 2 half-pulleys and the belt do not show any signs of wear, scoring and grease.
- Insert the new oil seals and O-rings on the movable half-pulley.
- Assemble the half-pulley on the ringlet with the appropriate protection sheath.
- Make sure the pins and collar are not worn, re-assemble the pins and collar.
- Use a greaser with a curved spout to lubricate the driven pulley unit with around 6 g of grease. This operation must be done through one of the holes inside the bushing until grease comes out of the opposite hole. This operation is necessary to avoid the presence of grease beyond the O-rings.

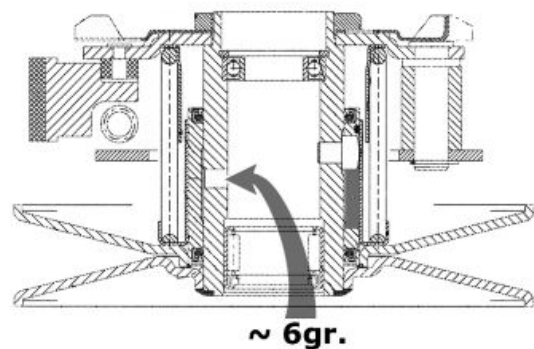

Specific tooling

020263Y Sheath for driven pulley fitting**Recommended products****AGIP GREASE SM 2 Grease for the tone wheel revolving ring**

Soap-based lithium grease containing NLGI 2 Molybdenum disulphide; ISO-L-XBCHB2, DIN KF2K-20

Inspecting the clutch spring

- Measure the unloaded length of the spring of the movable driven half-pulley.

Characteristic**Standard length:**

106 mm

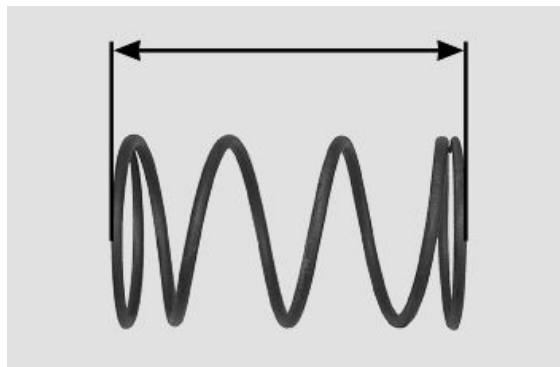
**Refitting the clutch**

- Check the thickness of the clutch mass friction material.

-The masses must not show traces of lubricants; otherwise, check the driven pulley unit.

N.B.

UPON RUNNING-IN, THE MASSES MUST EXHIBIT A CENTRAL CONTACT SURFACE AND MUST NOT BE DIFFERENT FROM ONE ANOTHER. VARIOUS CONDITIONS CAN CAUSE THE CLUTCH TO TEAR.

CAUTION

DO NOT OPEN THE MASSES USING TOOLS SO AS TO PREVENT A VARIATION IN THE RETURN SPRING LOAD.

Characteristic**Minimum thickness permitted:**

1 mm

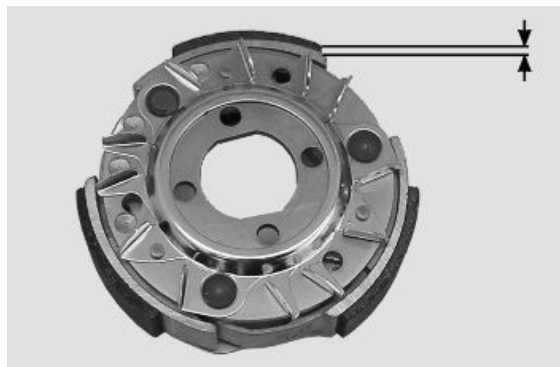

- Support the driven pulley spring compressor appropriate tool with the control screw in vertical axis.
- Arrange the tool with the medium length pins screwed in position "C" on the inside.
- Introduce the adapter ring 11 with the chamfering facing upwards.
- Insert the clutch on the adapter ring.
- Lubricate the end of the spring that abuts against the servo-system closing collar.
- Insert the spring with its plastic holder in contact with the clutch.
- Insert the driving belt into the pulley unit according to their direction of rotation.
- Insert the pulley unit with the belt into the tool.
- Slightly preload the spring.
- Make sure that the clutch is perfectly inserted into the adapter ring before proceeding to tighten the clutch nut.
- Place the tool in the clamp with the control screw on the horizontal axis.
- Fully preload the spring.
- Apply the clutch fixing nut and tighten it to the prescribed torque using the special 46x55 wrench.
- Loosen the tool clamp and insert the belt according to its direction of rotation.
- Lock the driven pulley again using the specific tool.
- Preload the clutch return spring with a traction/rotation combined action and place the belt in the smaller diameter rolling position.
- Remove the driven pulley /belt unit from the tool.

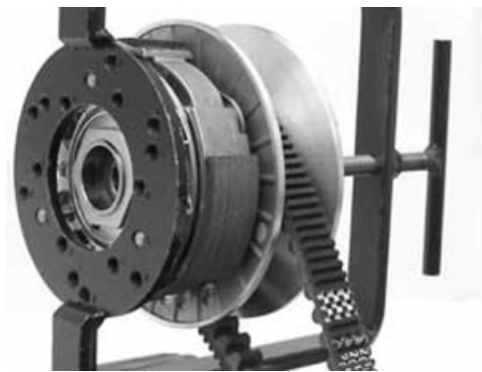

N.B.

DURING THE SPRING PRELOADING PHASE, BE CAREFUL NOT TO DAMAGE THE PLASTIC SPRING STOP AND THE BUSHING THREADING.

N.B.

FOR DESIGN REASONS, THE NUT IS SLIGHTLY ASYMMETRIC; THE FLATTEST SURFACE SHOULD BE MOUNTED IN CONTACT WITH THE CLUTCH.

Specific tooling

020444Y Tool for fitting/ removing the driven pulley clutch

020444Y011 adapter ring

020444Y009 46x55 Wrench

Locking torques (N*m)

Clutch unit nut on driven pulley 45 ÷ 50

Refitting the driven pulley

- Reassemble the clutch bell and spacer.

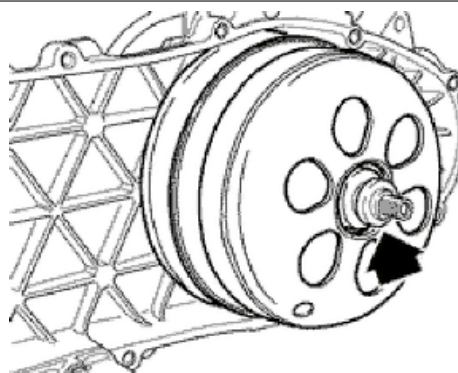

Drive-belt

During the wear check foreseen in the scheduled maintenance, check that the rim bottom of the tothing does not show signs of scores or cracking (see figure); otherwise, replace the belt.

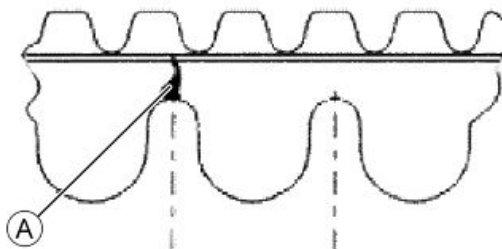

- Check that the driving belt is not damaged.
- Check the width of the belt.

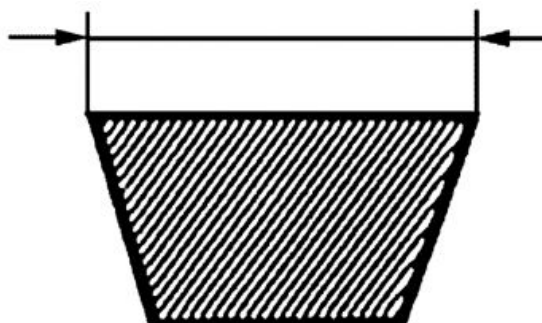

BELT SIZE

Specification	Desc./Quantity
Minimum width	21.5 mm
Standard width	22.5 ± 0.2 mm

Removing the driving pulley

- Lock the driving pulley with the specific tool as shown in the figure.
- Disassemble the central nut and the Belleville washer, remove the drive and the 2 washers.
- Remove the stationary half pulley and the steel washer.

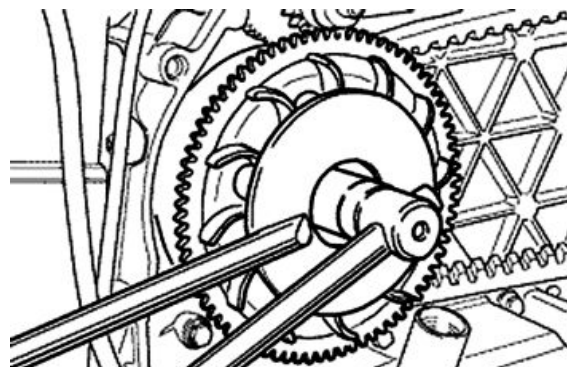

Specific tooling

020368Y driving pulley lock wrench

- Remove the belt and slide the movable half-pulley with the relevant bush, taking care of the falling free assembled rollers.
- Remove the return rollers plate with the relative guide pads.

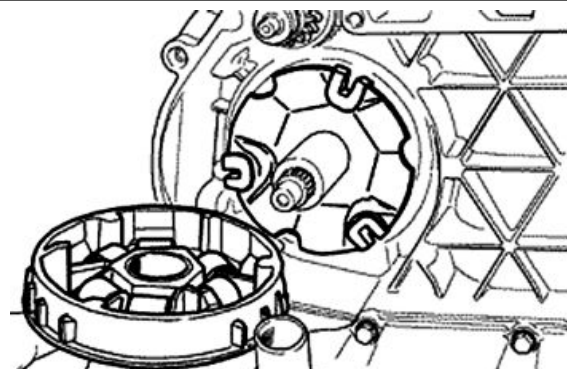

Inspecting the rollers case

- Check that the internal bushing is not abnormally worn and measure inner diameter.

N.B.

DO NOT LUBRICATE OR CLEAN THE BUSHING.

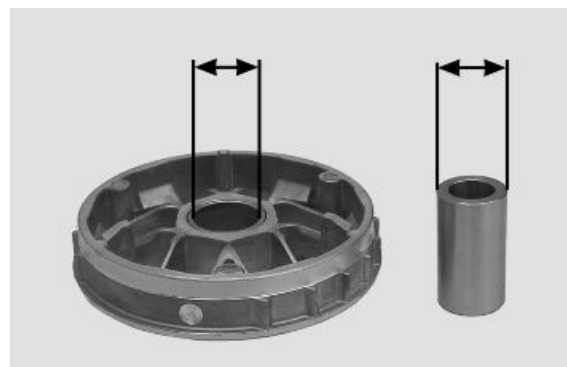

BUSHING ROLLER CONTAINER

Specification	Desc./Quantity
Maximum allowable diameter	Ø 26.121 mm
Standard diameter	Ø 26+0 +0.021 mm

BUSH SLIDE PULLEY

Specification	Desc./Quantity
Minimum diameter permitted	Ø 25.950 mm
Standard diameter	Ø 26-0.020 -0.041 mm

VARIABLE SPEED ROLLERS

Specification	Desc./Quantity
Minimum diameter permitted	Ø 18.5 mm
Standard diameter	19 ± 1 mm

- Check the guide shoes for the variator back-plate are not worn.
- Check there is no wear in the roller housing, and the surfaces in contact with the belt on either of the pulley halves.



Refitting the driving pulley

- Reassemble the parts of the unit (internal lining, fixed half-pulley, external lining, drive and nut), spread threadlock on the thread and screw the nut to the prescribed torque.
- Avoid half-pulley rotation using a calliper spanner.

N.B.

REPLACE THE NUT WITH A NEW ONE AT EVERY REFIT

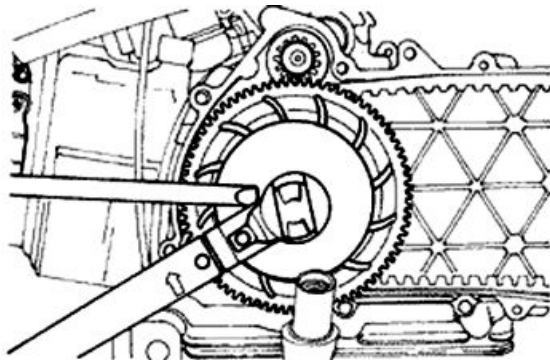

Specific tooling

020368Y driving pulley lock wrench

Recommended products

Loctite 243 Medium strength threadlock

Loctite 243 medium-strength threadlock

Locking torques (N*m)

Drive pulley nut 75 ÷ 83

Refitting the transmission cover

- Check the presence of the 2 centring dowels and the correct installation of the sealing gasket for the oil sump on the transmission cover.
- Replace the cover tightening the 10 screws at the specified torque.
- Refit the oil loading cap/bar.
- refit the steel washer and the driven pulley nut.
- Tighten the nut to the prescribed torque using the lock wrench and the torque wrench tools.
- Replace the plastic cover.



Specific tooling

020423Y driven pulley lock wrench

Locking torques (N*m)

Transmission cover screws 11 ÷ 13 Driven pulley shaft nut 54 ÷ 60

End gear

Removing the hub cover

- Empty the rear hub through the oil drainage tap located inside the hub cover
- Remove the brake shoe and relevant spring
- Remove the 7 flanged screws as shown in the figure.
- Remove the rubber cover and the brake pad lever sliding unscrewing the relevant retaining screw to reach the rear of the cover
- Take off the hub cover and relevant gaskets

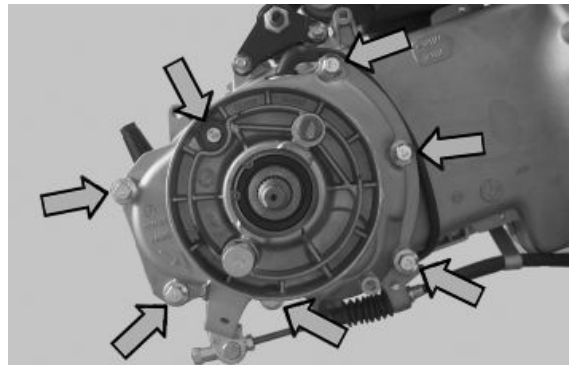

Removing the wheel axle

Remove the intermediate gear and the complete hub cover.

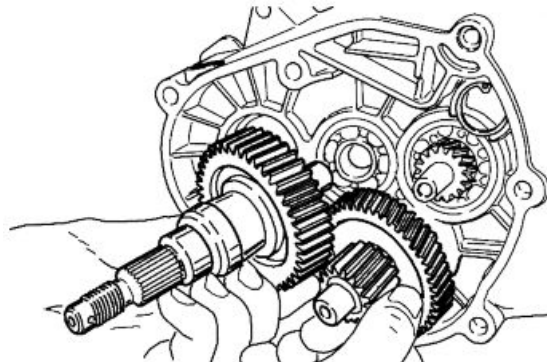

Removing the hub bearings

- Check the state of the bearings being examined (wear, clearance and noisiness). If faults are detected, do the following.
- Use the specific bearing extractor to remove the three 15 mm bearings (2 in the crankcase and 1 in the hub cover).

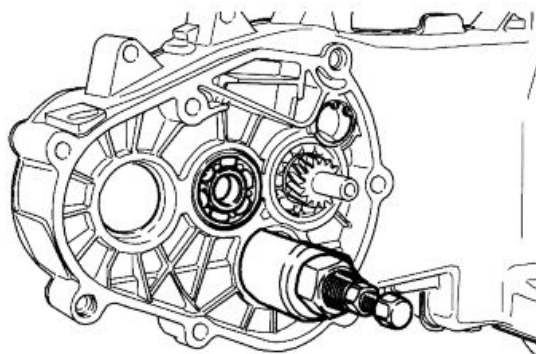

Specific tooling

001467Y009 Driver for OD 42-mm bearings

001467Y013 Pliers to extract \varnothing 15-mm bearings

Removing the wheel axle bearings

- Take out the clip on the outside of the gearbox cover.
- Remove the bearing with the adequate tools adequately supporting the hub cover, as shown in the figure.

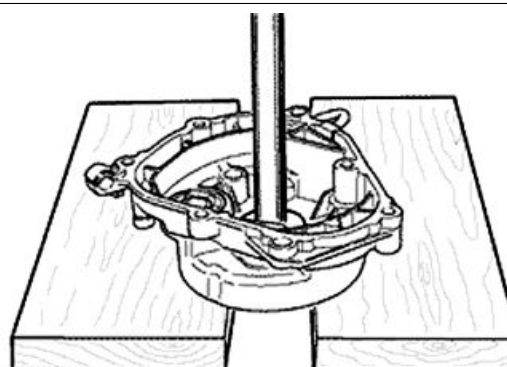

Specific tooling

020376Y Adaptor handle

020364Y 25-mm guide

With the appropriate tools, remove the oil seal as shown in the figure.

Specific tooling

020376Y Adaptor handle

020359Y 42x47-mm adaptor

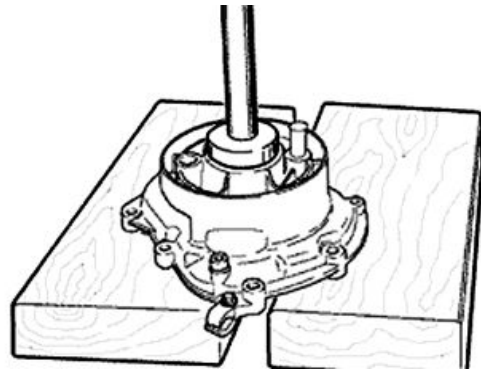

Removing the driven pulley shaft bearing

If it is necessary to remove the driven pulley shaft, from the relevant bearing and oil seal, remove driven pulley.

- Extract the driven pulley shaft from its bearing.
- Remove the oil guard using a screwdriver, working from inside the bearing and being careful not to damage the housing, make it come out of the belt transmission side.
- Remove the seeger ring shown in the figure

With the sectional punch, remove the driven pulley shaft bearing.

Specific tooling

020376Y Adaptor handle

020375Y Adaptor 28 x 30 mm

020363Y 20 mm guide

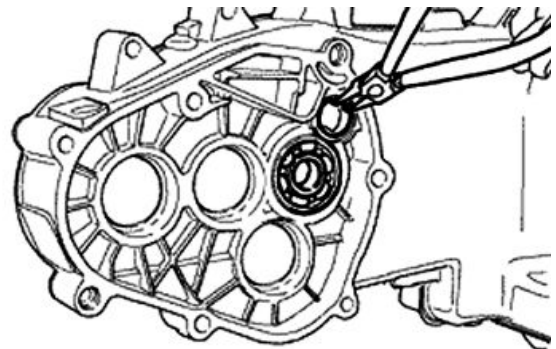

See also

[Removing the driven pulley](#)

Inspecting the hub shaft

- Check the three shafts for wear or distortion of the toothed surfaces, the bearing housings, and the oil seal housings.
- In case of anomalies, replace the damaged components.



Inspecting the hub cover

- Check that the fitting surface is not dented or distorted.
 - Check the capacity of the bearings and the brake camshaft.
 - If faults are found, replace the hub cover.
-

Refitting the driven pulley shaft bearing

- Heat up the parts using the specific heat gun

Specific tooling

020150Y Air heater support

020151Y Air heater

- Reassemble the driven pulley axle bearing positioning it with ball bearing in view from the inside of the hub cover using the adequate tools

Specific tooling

020376Y Adaptor handle

- Refit the Seeger ring with the opening facing the bearing as shown in the figure and fit a new oil guard flush with the crankcase.

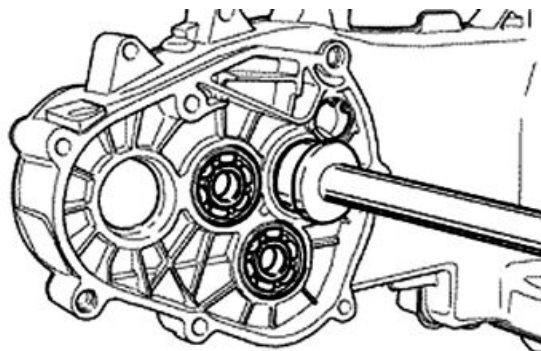

Refitting the wheel axle bearing

- Heat up the parts using the specific heat gun

Specific tooling

020151Y Air heater

020150Y Air heater support

- The wheel axle bearing on the cover, should be assembled with the specific tools

Specific tooling

020364Y 25-mm guide

020360Y Adaptor 52 x 55 mm

020376Y Adaptor handle

- Assemble the Seeger ring.
- Assemble the oil seal flush with the internal surface as shown in the figure to the hub using the adequate tools and with the seal lip towards the inside of the hub.

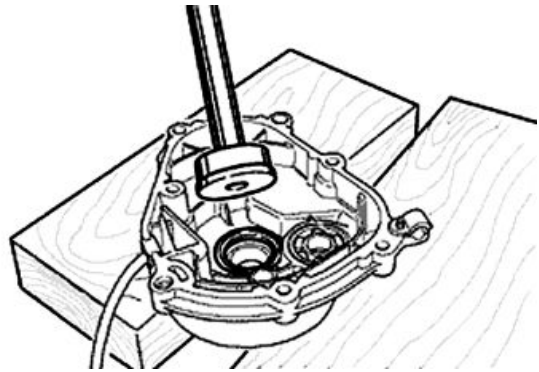

Specific tooling

020376Y Adaptor handle

020360Y Adaptor 52 x 55 mm

Refitting the hub cover bearings

- For the fitting of the hub box bearings the engine crankcase and the cover must be heated with the specific heat gun.

Specific tooling

020150Y Air heater support

020151Y Air heater

- The three 15 mm bearings must be fitted using the appropriate tools.

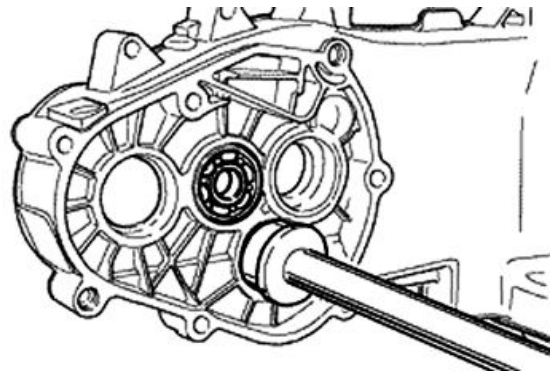

Refitting the hub bearings

- Insert the cover prepared in the crankcase taking care of inserting the gear of the pulley shaft on the intermediary gear.

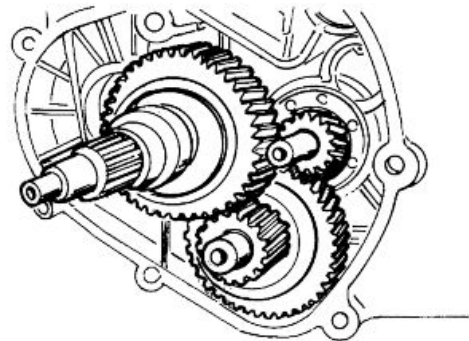

Refitting the ub cover

- Fit a new gasket together with the centring dowels.
- Fit the gearbox cover, making sure the breather pipe is in the correct position.
- Screw the 7 screws to the specified torque, positioning the support plate of the pipe in the position shown in the figure.

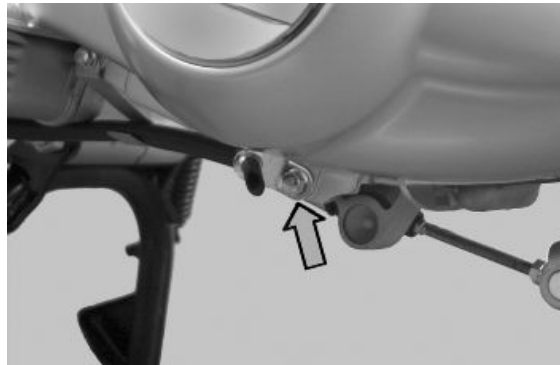

Locking torques (N*m)

Rear hub cap screw 24 ÷ 27

Flywheel cover

Cooling hood

- Remove the housing acting on the 4 retaining screws.

CAUTION

DURING REMOVAL SLIDE THE HOUSING CONNECTOR ON THE HOUSING.

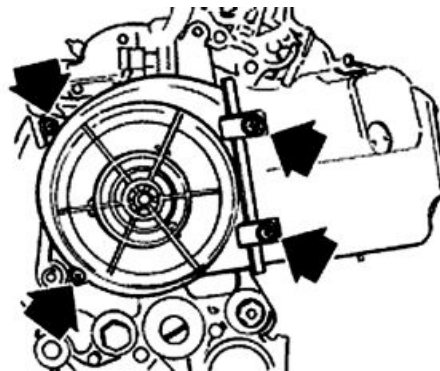

- Loosen the clamp and remove the carburettor from the manifold.
- Remove the complete manifold acting on the 2 retainers as shown in the figure.
- Remove the 2 self threading screws, left and right and the lateral base retaining screw on the crankcase base.
- Take off the housings.
- Remove the gasket seal of the housing on the head.

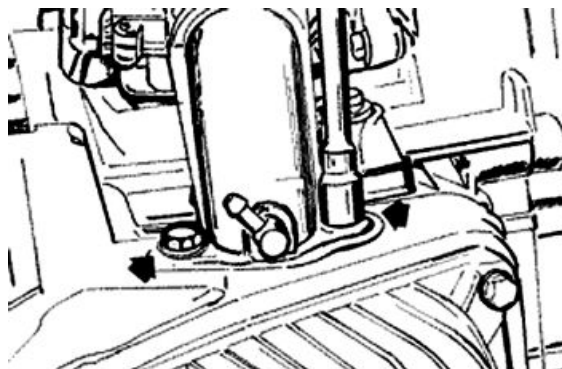

N.B.

IF THE FLYWHEEL HOUSING IS NOT REMOVED, IT IS ALSO NECESSARY TO REMOVE THE TWO KNOB SCREWS.

On the vehicles equipped with the engines mentioned if they are losing a full circle at full gas, we suggest to intervene on the vacuum socket inserting on the inlet manifold widening the hole from 0.4 mm to 1.5

mm. Remember that such operation must have performed on a disassembled manifold which must be cleaned afterwards.

Cooling fan

- Refit the parts in reverse order of the removal operation.
- Make sure that there are spacers with the two rear retainers of the housing.
- The long spacers should be in a high position.

CAUTION

TAKE CARE TO CORRECTLY POSITION THE FLYWHEEL CONNECTOR.

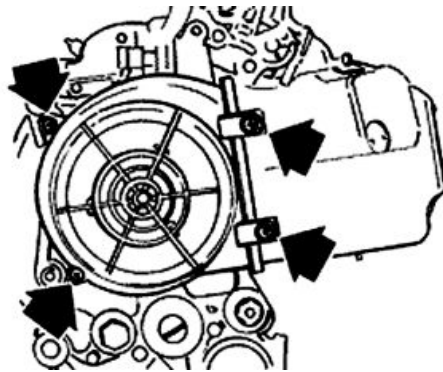

- Remove the cooling fan by acting on the three fixings indicated in the figure.

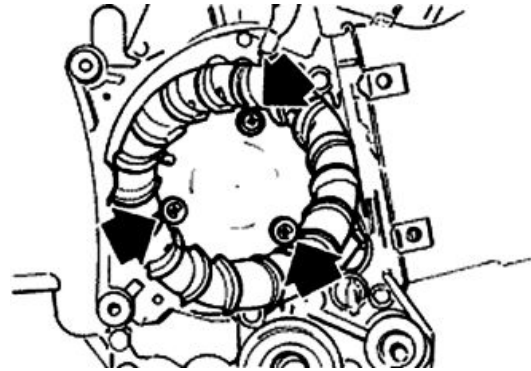

Removing the stator

- Remove the electric terminal of the minimum oil pressure switch.
- Remove the two Pick-Up screws and the one for the wiring harness bracket as well as the two stator fixing screws shown in the figure.
- Remove the stator and its wiring.

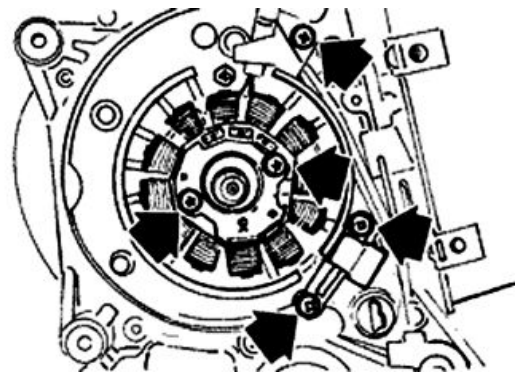

Refitting the stator

- Refit the stator and flywheel carrying out the removal procedure in reverse, tightening the retainers to the specified torque.
- Place the cable harness as shown in the figure.

N.B.

THE PICK-UP WIRE SHOULD BE POSITIONED BETWEEN THE UPPER SCREW AND THE REFERENCE PIN AS SHOWN IN THE DETAIL DRAWING.

Locking torques (N*m)

Stator assembly screws 3 ÷ 4

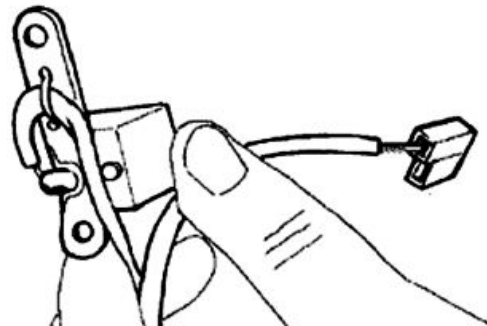
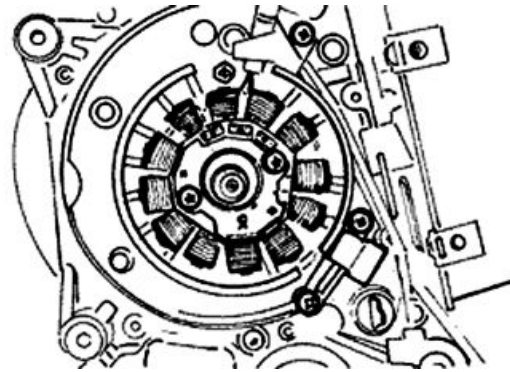

Flywheel and starting

Removing the starter motor

- Disconnect the electric terminals.
- Undo the two screws indicated.

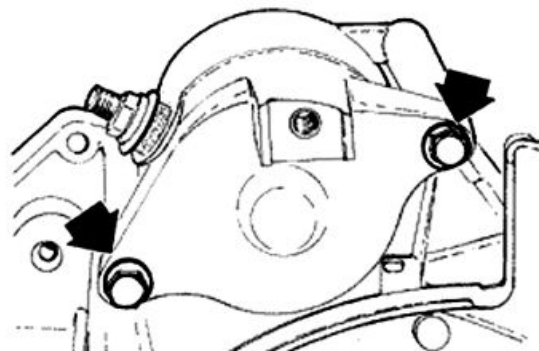

Removing the flywheel magneto

- Lock the rotation of the flywheel using the calliper spanner.
- Remove the nut.

CAUTION

THE USE OF A CALLIPER SPANNER OTHER THAN THE ONE SUPPLIED COULD DAMAGE THE STATOR COILS

Specific tooling

020565Y Flywheel lock calliper spanner

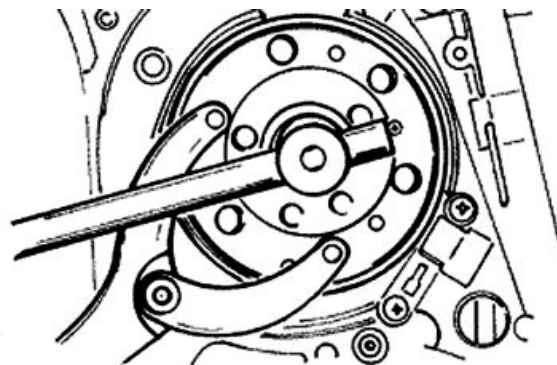

- Extract the flywheel with the extractor.

Specific tooling

008564Y Flywheel extractor

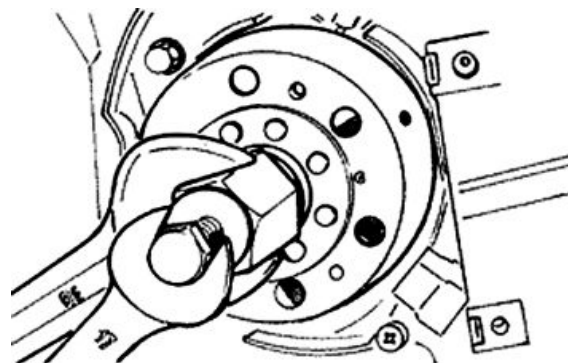

Inspecting the flywheel components

- Check the integrity of the internal plastic parts of the flywheel and the Pick-Up control plate.

Refitting the flywheel magneto

- Fit the flywheel being careful to insert the key properly.
- Lock the flywheel nut to the prescribed torque
- Check that the Pick-Up air gap is between 0.34 ÷ 0.76 mm.

The air gap cannot be modified when assembling the Pick-Up.

Different values result from deformations visible on the Pick-Up support.

N.B.

A VARIATION IN THE AIR GAP DISTANCE MODIFIES THE IGNITION SYSTEM IDLE SPEED

Locking torques (N*m)

Flywheel nut 52 ÷ 58

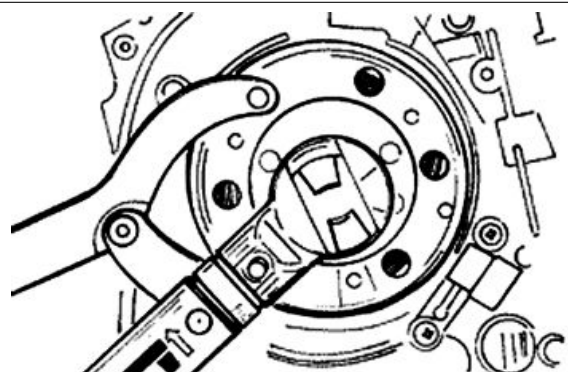

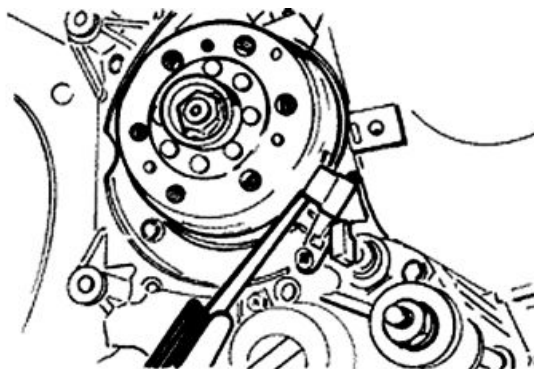

Refitting the starter motor

- Fit a new O-ring on the starter and lubricate it.
- Fit the starter on the crankcase, locking the two screws to the prescribed torque.

N.B.

REFIT THE REMAINING PARTS AS DESCRIBED IN THE CYLINDER HEAD, TIMING, LUBRICATION, FLYWHEEL AND TRANSMISSION CHAPTERS.

Locking torques (N*m)

Starter motor fixing screw 11 ÷ 13

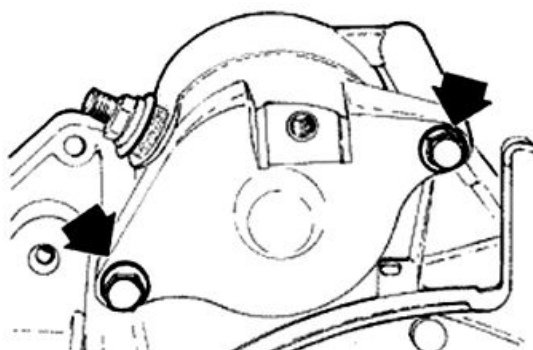

Cylinder assy. and timing system

Removing the timing system drive

- Remove the parts listed below first: transmission cover, belt driving pulley, oil pump pulley cover and pinion separator washer.
- Undo the screws indicated and remove the tappet cover.

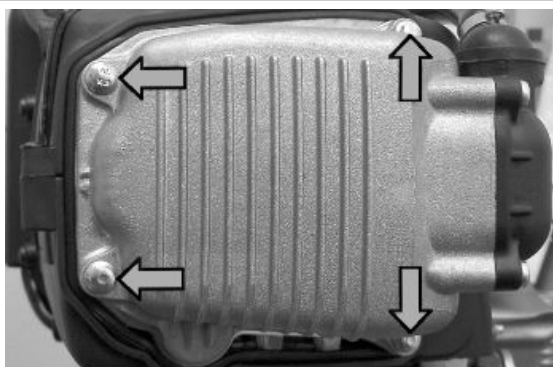

-
- Unscrew the central screw and remove the automatic valve-lifter retaining cover, as shown in the figure.

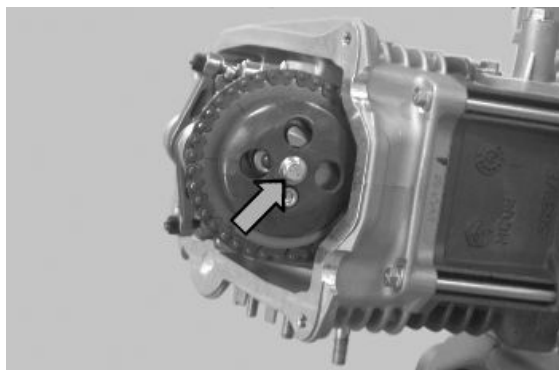

-
- Remove the return spring of the automatic valve-lifter assembly and the automatic valve-lifter assembly and its washer.

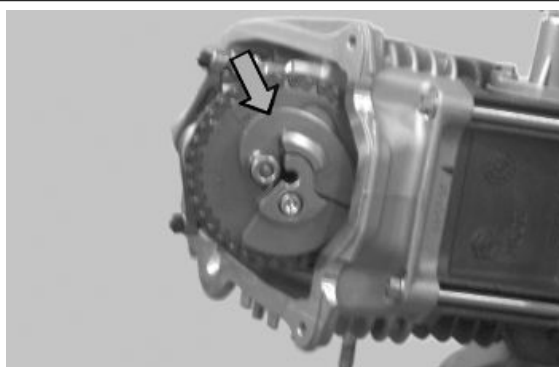

-
- Loosen the central screw on the tensioner.
 - Remove the two screws indicated in the figure.

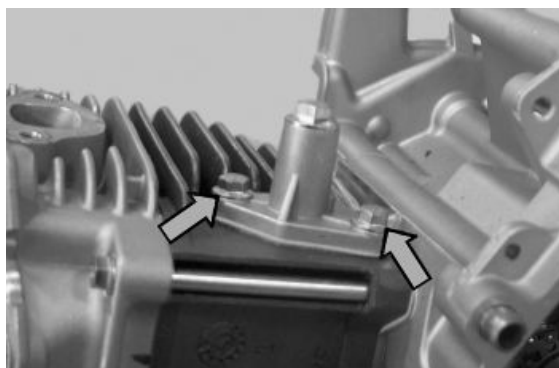

-
- Remove the tensioner with its gasket.
 - Undo the screw indicated and remove the counterweight.

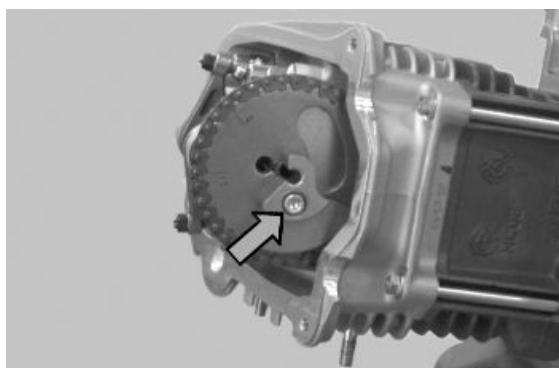

-
- Remove the camshaft control pulley with its washer.

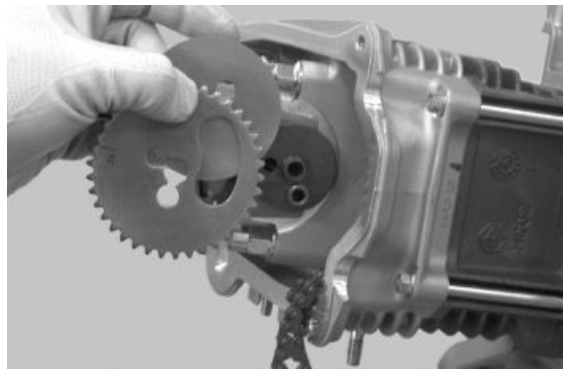

- Undo the screws indicated in the figure, the spacer and the tensioner pad.

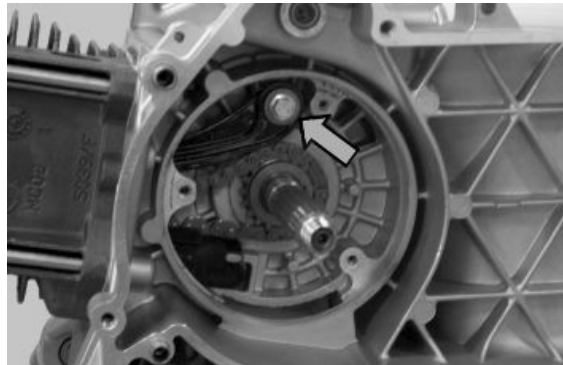

- Remove the command sprocket wheel and the timing chain.



The chain tensioning pad must be removed from the transmission side. As regards the lower chain guide pad, it may only be removed after the head has been removed.

N.B.

IT IS ADVISABLE TO MARK THE CHAIN IN ORDER TO ENSURE THAT THE INITIAL DIRECTION OF ROTATION IS MAINTAINED.

See also

[Removing the driving pulley](#)
[Removal](#)

Transmission cover

Removing the cam shaft

- Remove the two screws and the cam shaft re-tainer shown in the diagram.

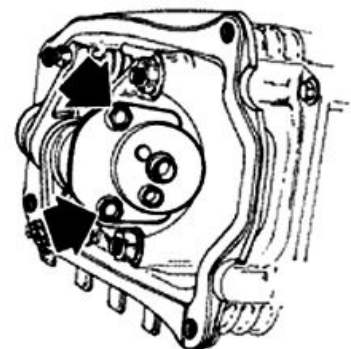

- Remove the cam shaft.

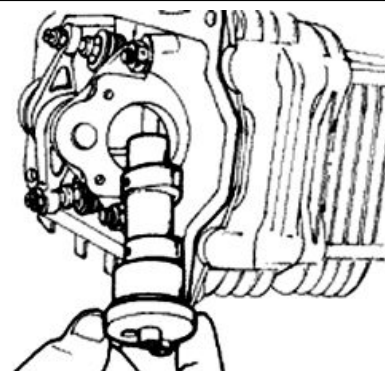

- Remove the pin of the rocking levers from the flywheel side holes.
- Remove the rocking levers and the elastic washer.

N.B.

MARK THE ROCKING LEVERS ASSEMBLE POSITION, SO AS TO AVOID THE INVERSION OF INLET WITH THE OUTLET.

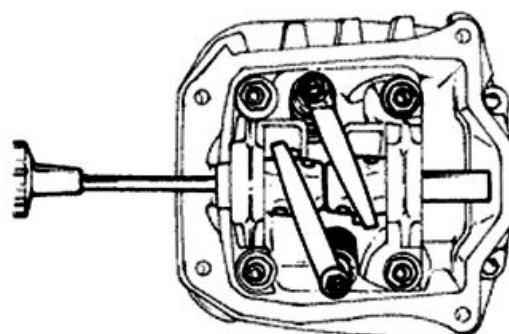

Removing the cylinder head

- Remove the spark plug.
- Remove the 2 side fixings shown in the figure.
- Loosen the 4 head-cylinder fastening nuts in two or three stages and in criss-cross fashion.
- Remove the head, the two centring dowels and the gasket.

N.B.

IN CASE OF NEED, THE HEAD MAY BE REMOVED WITH THE CAMSHAFT, PINS, ROCKING LEVERS AND FIXING BRACKET. THE HEAD CAN ALSO BE REMOVED WITHOUT REMOVING THE CHAIN AND THE DRIVING SHAFT CHAIN TIGHTENER.

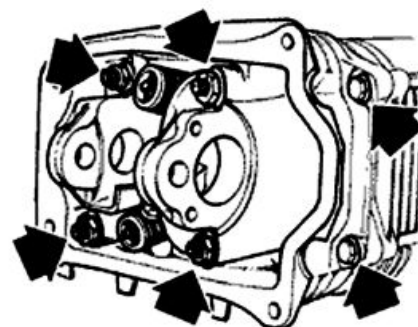

Removing the valves

- Using the specific tool fitted with the element shown in the figure, remove the cotters, the plates and the spring between the valves.

Specific tooling

020382Y Valve cotters equipped with part 012 removal tool

020382Y011 adapter for valve removal tool

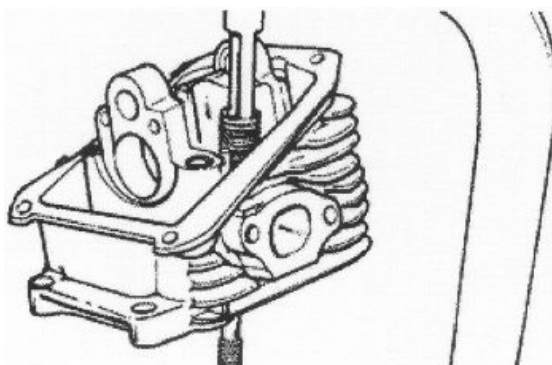

- Remove the oil seals with the appropriate tool.
- Remove the lower spring supports.

Specific tooling

020431Y Valve oil seal extractor

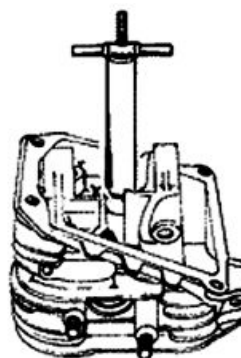

Removing the cylinder - piston assy.

- Remove the chain guide pad.
- Remove the cylinder.
- Remove the cylinder base gasket.

CAUTION

TO AVOID DAMAGING THE PISTON, SUPPORT IT WHILE REMOVING THE CYLINDER.

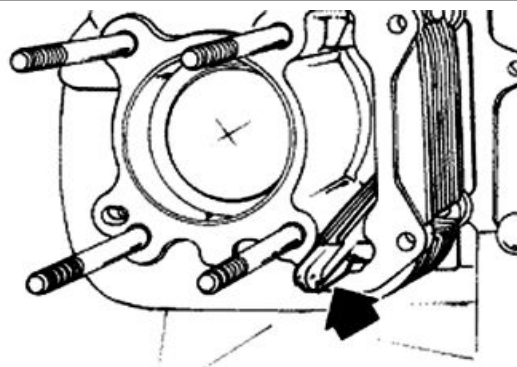

- Remove the two stop rings, the wrist pin and the piston.
- Remove the 3 piston rings from the piston.

N.B.

BE CAREFUL NOT TO DAMAGE THE PISTON RINGS DURING REMOVAL.

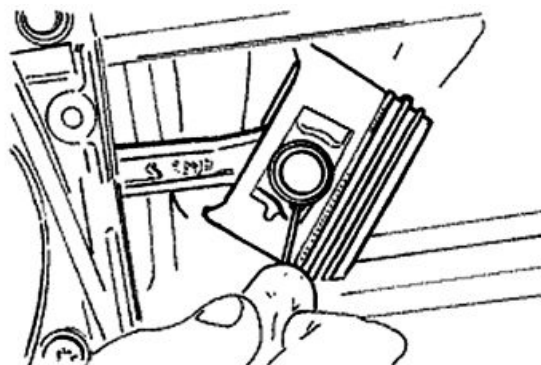

Inspecting the small end

- Measure the internal diameter of the small end using an internal micrometer.

N.B.

IF THE DIAMETER OF THE ROD SMALL END EXCEEDS THE MAXIMUM DIAMETER ALLOWED, SHOWS SIGNS OF WEAR OR OVERHEATING REPLACE THE CRANKSHAFT AS DESCRIBED IN THE "CRANKCASE AND CRANK-SHAFT" CHAPTER".

Characteristic

Rod small end check-up: Maximum diameter

15.030 mm

Rod small end check-up: Standard diameter

15 +0.015+0.025 mm

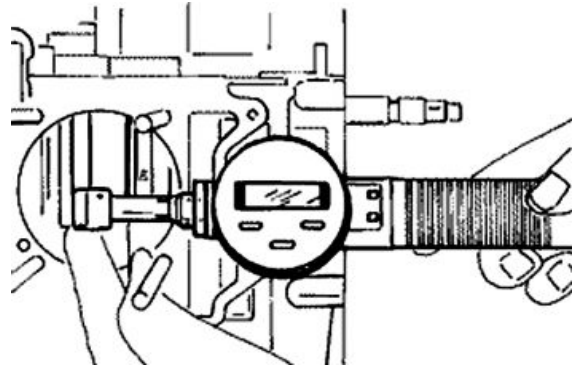

Inspecting the wrist pin

- Check the outer diameter of the gudgeon pin.

Characteristic

Standard pin diameter

14.996 ÷ 15 mm

Minimum diameter permitted

∅ 14.994 mm

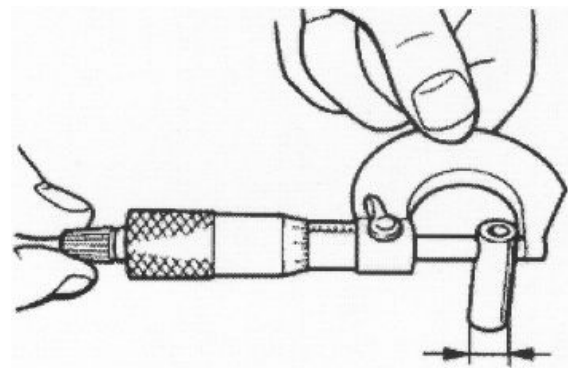

- Calculate the piston pin coupling clearance.

N.B.

THE PIN HOUSINGS HAVE 2 LUBRICATION CHANNELS. FOR THIS REASON MEASUREMENT OF THE DIAMETER MUST BE CARRIED OUT ACCORDING TO THE AXIS OF THE PISTON.

Characteristic

Piston pin bore - standard diameter

∅ 15+0.001 +0.006



- Measure the outside diameter of the piston, perpendicular to the gudgeon pin axis.
- Measure 36.5 mm from the piston crown's shown in the figure.

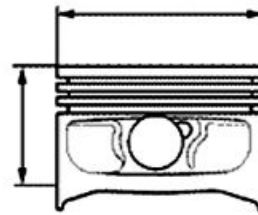

- Using a bore meter, measure the inner cylinder diameter at three different points according to the directions shown in the figure.
- Check that the coupling surface with the head is not worn or misshapen.
- Pistons and cylinders are classified into categories based on their diameter. The coupling is carried out in pairs (A-A, B-B, C-C, D-D).

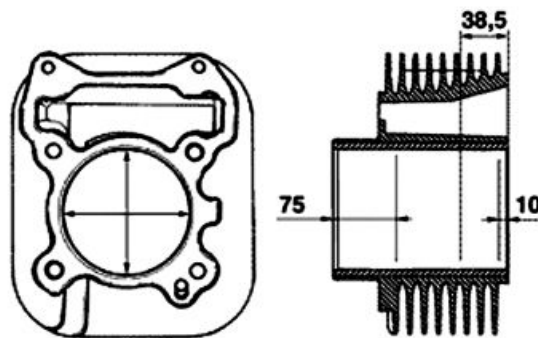

Characteristic

Maximum allowable run-out:

0.05 mm

- The cylinder rectifying operation should be carried out with a surfacing that respects the original angle.
- The cylinder surface roughness should be 0.9 micron.
- This is indispensable for a good seating of the sealing rings, which in turn minimises oil consumption and guarantees optimum performance.
- The pistons are oversized due to cylinder rectification and are subdivided into three categories 1st, 2nd, 3rd with 0.2-0.4-0.6 mm oversize. They are also classified into 4 categories A-A, B-B, C-C, D-D.

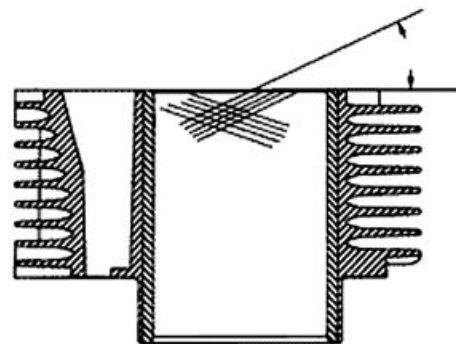

Inspecting the piston

- Carefully clean the seal housings.
- Measure the coupling clearance between the seal rings and the grooves using suitable sensors, as shown in the diagram.
- If the clearance is greater than that indicated in the table, replace the piston.

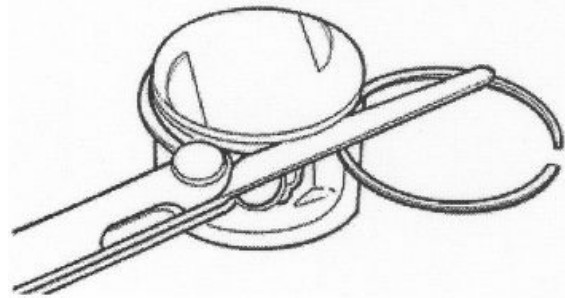

STANDARD COUPLING CLEARANCE

Name	Description	Dimensions	Initials	Quantity
Top piston ring		0.025 ÷ 0.070		
Middle piston ring		0.015 ÷ 0.060		
oil scraper		0.015 ÷ 0.060		

MAXIMUM ADMITTED CLEARANCE AFTER USE

Name	Description	Dimensions	Initials	Quantity
Top piston ring		0.080 mm		
Middle piston ring		0.070 mm		
oil scraper		0.070 mm		

Removing the piston

- Install piston and wrist pin onto the connecting rod, aligning the piston arrow the arrow facing towards the exhaust.
- Fit the pin stop ring onto the appropriate tool.

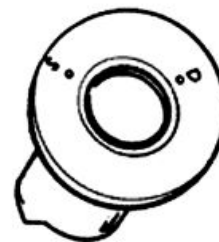

Specific tooling

020430Y Pin lock fitting tool

- With the opening in position indicated on the tool, take stop ring in the closed position using the punch.
- Fit the wrist pin stop using the plug as shown in the figure

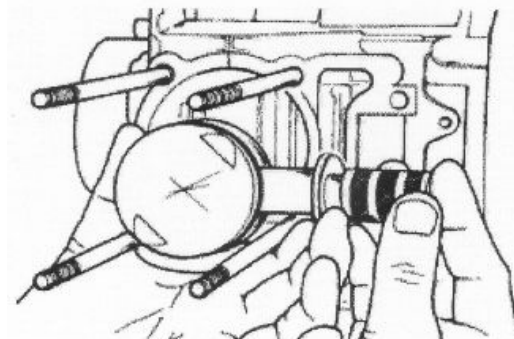

N.B.

THE TOOL FOR INSTALLING THE STOP RINGS MUST BE USED MANUALLY.

CAUTION

USING A HAMMER TO POSITION THE RINGS CAN DAMAGE THE LOCKING HOUSING.

Refitting the piston rings

- Place the oil scraper spring on the piston.
- Refit the oil scraper ring with the join of spring ends on the opposite side from the ring gap and the word 'TOP' towards the crown of the piston. The tapered side of the middle piston ring should always be facing away from the crown of the piston.
- Fit the middle piston ring with the identification letter facing the crown of the piston. In any case, the step must be facing opposite the piston top.
- Fit the top piston ring with the word 'top' or the reference mark facing the crown of the piston.
- Offset the piston ring gaps on the three rings by 120° to each other as shown in the figure.
- Lubricate the components with engine oil.

N.B.

SO AS TO OBTAIN THE BEST CONFIGURATION THE 2 SEALING RINGS ARE MADE WITH A CONTACT CONICAL CYLINDER SECTION.

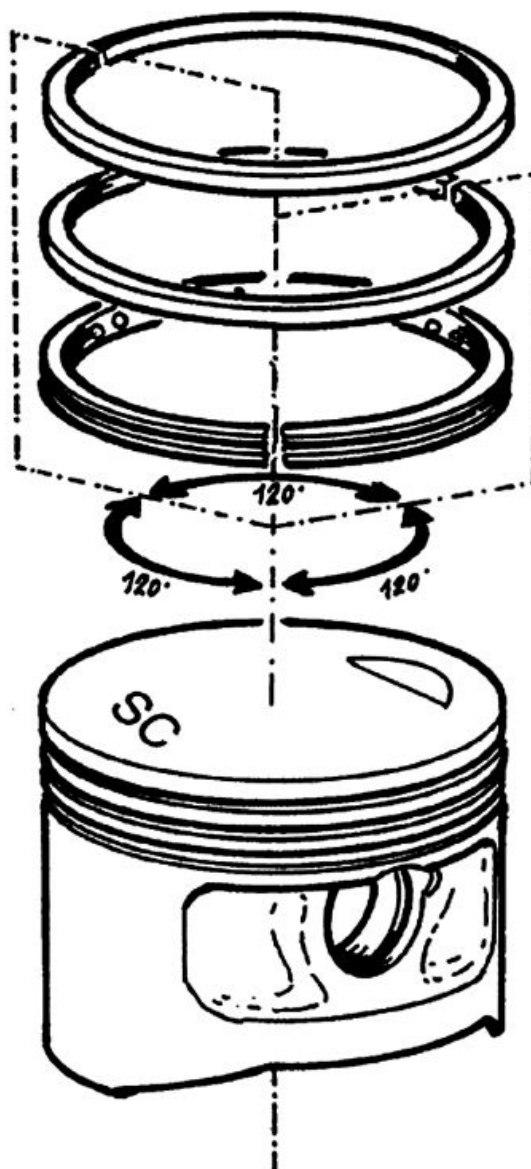

Refitting the cylinder

- Insert the cylinder base gasket with the thickness determined above.
- Using the fork support and the piston ring retaining band, refit the cylinder as shown in the figure.

N.B.

BEFORE FITTING THE CYLINDER, CAREFULLY BLOW OUT THE LUBRICATION DUCT AND OIL THE CYLINDER BARREL.

Specific tooling

020426Y Piston fitting fork

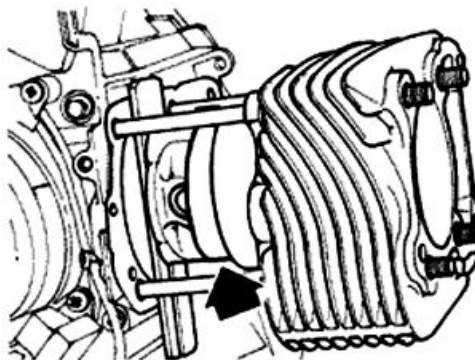

020427Y Piston fitting band

Inspecting the cylinder head

- Using a trued bar check that the cylinder head surface is not worn or distorted.
- Check that the camshaft and rocking lever pin bearings show no signs of wear.
- Check that the cylinder head cover surface, the intake manifold and the exhaust manifold are not worn.

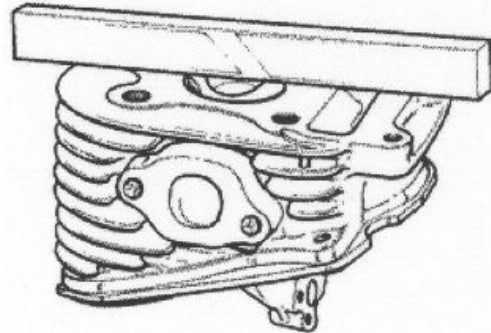

Characteristic

Maximum admitted unevenness: Head check
0.05 mm

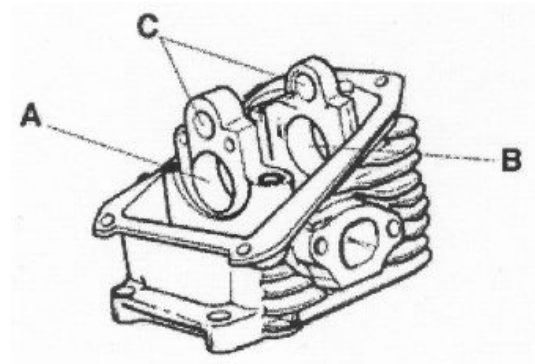

STANDARD DIAMETER

Specification	Desc./Quantity
Standard diameter	A Ø 32.5 ÷ 32.525
Standard diameter	B Ø 20 ÷ 20.021
Standard diameter	C Ø 12 ÷ 12.018

Inspecting the timing system components

- Check that the guide shoe and the tensioner shoe are not worn out.
- Ensure that the camshaft drive pulley, the chain assembly and the sprocket wheel are not worn.
- If signs of wear are found, replace the parts. if the chain, pinion or pulley are worn, replace the whole assembly.

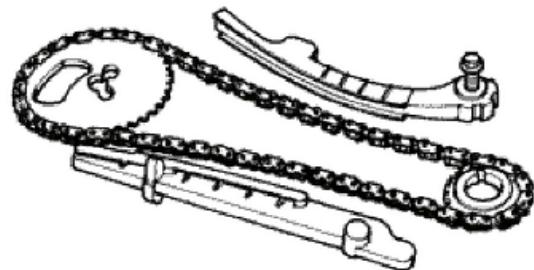

- Remove the central screw and the tensioner spring. Check that the one-way mechanism is not worn.
- Check the condition of the tensioner spring.
- If examples of wear are found, replace the whole assembly.



Inspecting the valve sealings

- Measure the width of the sealing surface on the valve seats.

VALVE SEAL SURFACE «A»

Specification	Desc./Quantity
Inlet valve - seal surface	2.4 ÷ 2.8 mm
Outlet valve - seal surface	2.2 ÷ 2.6 mm

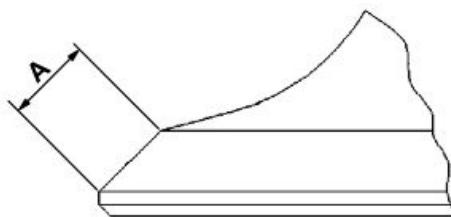

Inspecting the valve housings

- Remove any carbon formation from the valve guides.
- Measure the inside diameter of each valve guide.
- Take the measurement at three different heights in the rocker arm push direction.

Characteristic

Standard drainage guide diameter

5.012 mm

Standard inlet guide diameter

5.012 mm

- If the width of the impression on the valve seat or the diameter of the valve guide exceed the specified limits, replace the cylinder head.

- Check width of the impression on the valve seat «V»

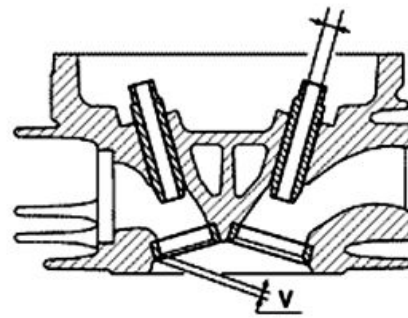

Characteristic

Wear limits:

Max. 1.6 mm.

Inspecting the valves

- Measure the diameter of the valve stems in the three positions indicated in the diagram.

- Calculate the clearance between valve and valve guide.

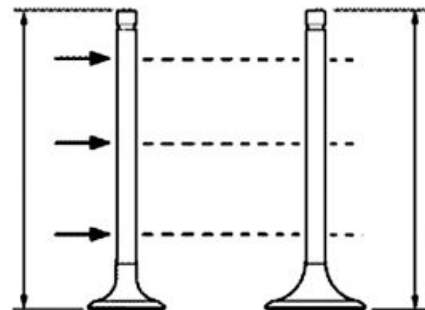

Characteristic

Minimum diameter admitted - Inlet:

4.96 mm

Minimum diameter admitted - Outlet:

4.95 mm

Standard clearance - Inlet:

0.013 ÷ 0.040 mm

Standard clearance - Outlet:

0.025 ÷ 0.052 mm

Maximum clearance admitted- Inlet:

0.062 mm

Maximum clearance admitted - Outlet:

0.072 mm

- Check that there are no signs of wear on the contact surface with the articulated register terminal.

- If the sealing surface on the valves is wider than the specified limit, damaged in one or more points or curved, replace the valve with a new one.

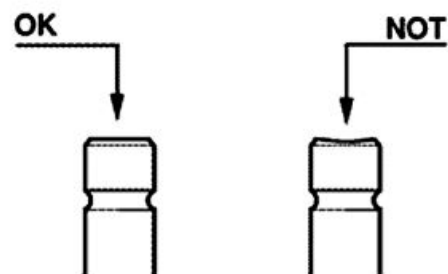

Characteristic

Standard valve length - Inlet:

80.6 mm

Valve standard length: drainage

79.6 mm

- If the checks above give no failures, you can use the same valves. For best sealing results, it is advisable to grind the valves. Grind the valves gently with a fine-grained lapping compound. During grinding, keep the cylinder head in a horizontal position. This will prevent the lapping compound residues from penetrating between the valve stem/guide coupling.

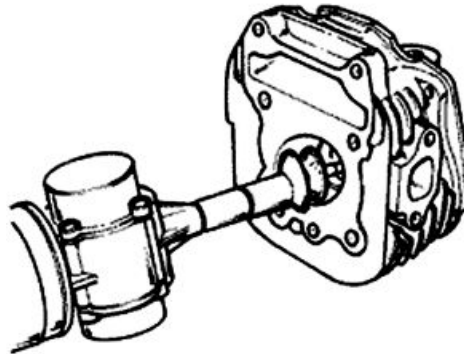

CAUTION

TO AVOID SCORING THE CONTACT SURFACE, DO NOT KEEP ROTATING THE VALVE WHEN NO LAPPING COMPOUND IS LEFT. CAREFULLY WASH THE CYLINDER HEAD AND THE VALVES WITH A SUITABLE PRODUCT FOR THE TYPE OF LAPPING COMPOUND BEING USED.

- Insert the valves into the cylinder head.
 - Test the 2 valves alternatively.
 - The test is carried out by filling the manifold with petrol and checking that the head does not ooze through the valves when these are just pressed with the fingers.

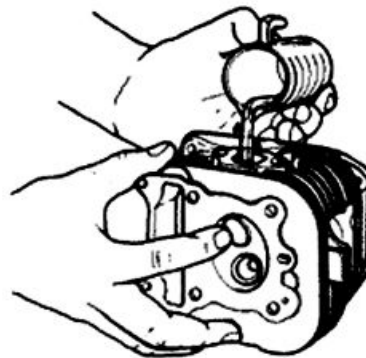

Inspecting the springs and half-cones

- Check that the upper and lower supporting spring caps, the cotters and the oil seal show no sign of abnormal wear. Replace a component when worn.
 - Check the unloaded spring length.

Characteristic

Valve spring length

33.9 ÷ 34.4 mm

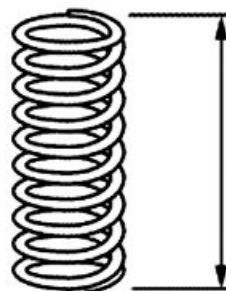

Refitting the valves

- Lubricate the valve guides with engine oil.
- Place the lower plates of the valve spring on the head.
- Use the punch to fit the 2 sealing rings one at a time.

Specific tooling

020306Y Punch for assembling valve seal rings

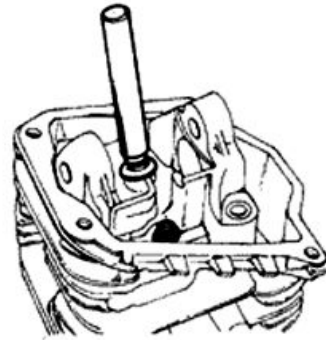

- Fit the valves, the springs and the spring retaining caps. Using the appropriate tool with adapter 11, compress the springs and insert the cotters in their seats.

Specific tooling

020382Y Valve cotters equipped with part 012 removal tool

020382Y011 adapter for valve removal tool

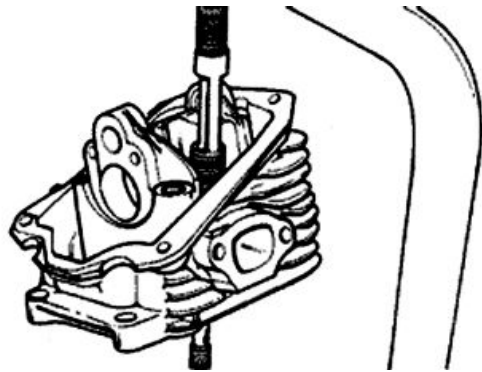

Inspecting the cam shaft

- Inspect the cam shaft for signs of abnormal wear on the cams.

Characteristic

Standard diameter Bearing A

Ø: 32.5 mm -0.025 -0.050 mm

Standard diameter Bearing B

20 -0.020 -0.041 mm

Minimum admitted diameter bearing A

Ø: 32.440 mm

Minimum admitted diameter bearing B

Ø: 19.950 mm

Inlet cam height

27.512 mm

Outlet cam height

27.212 mm

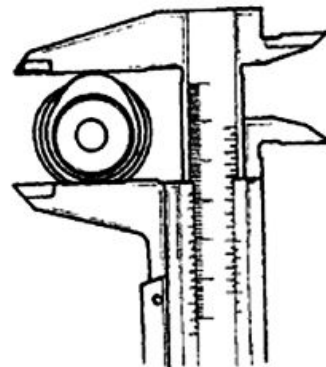
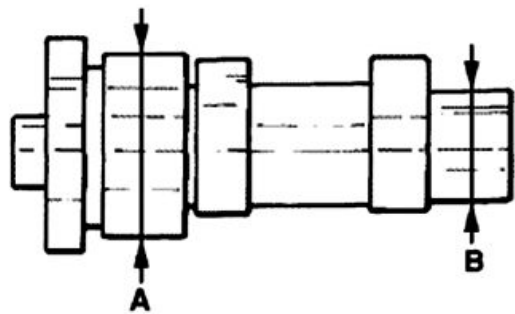

- Check there is no wear on the cam shaft retaining plate and its associated groove on the cam shaft.
- If any of the above dimensions are outside the specified limits, or there are signs of excessive wear, replace the defective components with new ones.

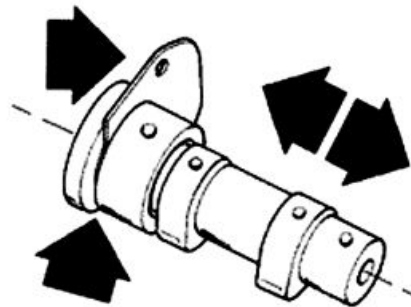

Characteristic

Maximum axial clearance admitted

0.42 mm

- Check there are no signs of wear on the automatic valve-lifter cam, or the end-of stroke roller, or the rubber buffer on the automatic valve-lifter retaining cover.
- Check that the valve lifting spring has not yielded.
- Replace any defective or worn components.

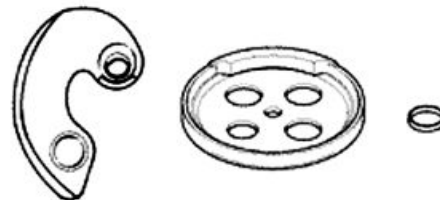

- Check there are no signs of scoring or wear on the rocking lever bolt.
- Check there are no signs of wear on the pad from contact with the cam and on the jointed adjustment plate.
- Measure the internal diameter of each rocking lever.
 - Check that the elastic washer dedicated to the axle clearance of the rocking levers is not worn.
- In case of anomalies, replace the damaged components.

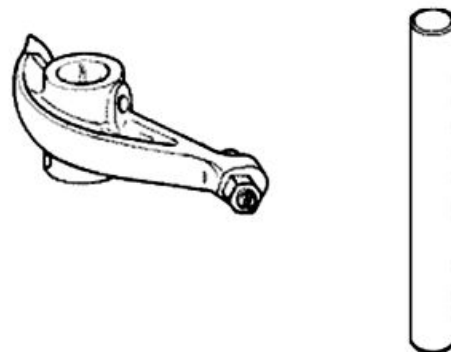

Characteristic

Minimum diameter permitted

Ø 11.970 mm

Maximum diameter admitted

Ø 12.030 mm

Refitting the head and timing system components

- Fit the timing chain guide pad.
- Insert the head and cylinder centring dowels, fit the head gasket and the head on the cylinder.
- Screw the nuts and lock them in a crossed sequence and in 2 or 3 stages to the specific torque.

Locking torques (N*m)

Nuts fixing head to cylinder (*) 10 + 90° + 90° [further tighten by 90° with new stud bolts].

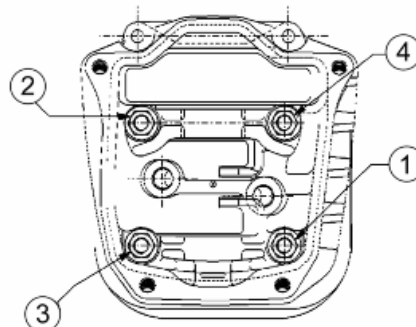

- Fit the two screws on the outside of the timing chain side and tighten them to the specified torque.

N.B.

BEFORE INSTALLING THE HEAD, MAKE SURE THAT THE LUBRICATION CHANNEL IS CLEAN USING A COMPRESSED AIR JET.

Locking torques (N*m)

Head fixing screws (external) 11 ÷ 13

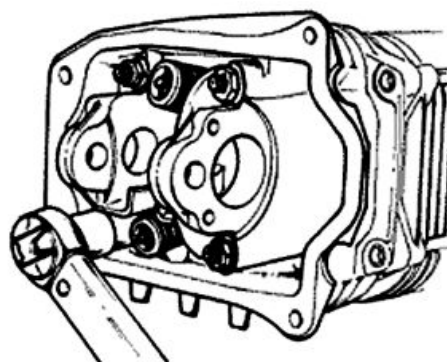

- Fit the timing chain sprocket wheel on the crankshaft, with the chamfer facing the insertion side.
- Loop the timing chain around the sprocket on the crankshaft.
- Fit the tensioner pad by the cylinder head.
- Fit the spacer and the screw fastener.
- Fit the pin, the outlet rocking lever, the spring washer and the inlet rocking lever.
- Lubricate the 2 rocking levers through the holes at the top.
- Lubricate the 2 bearings and insert the camshaft in the cylinder head with the cams opposing the rocking levers.

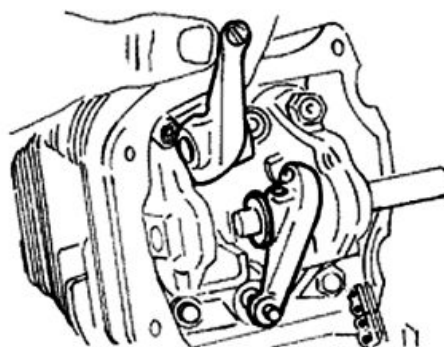

- Insert the retention plate and tighten the two screws shown in the figure to the prescribed torque.

Locking torques (N*m)

Camshaft retention plate screw 5 - 6

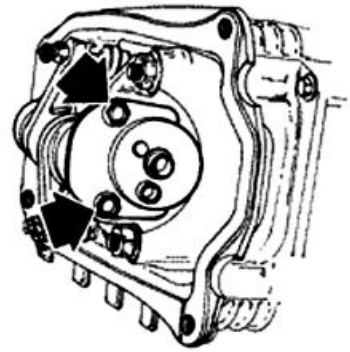

- Refit the spacer on the cam shaft.
- Rotate the engine so that the piston is at top dead centre, using the reference marks on the flywheel and the crankcase.
- While doing so, fit the chain onto the control camshaft pulley and keep the reference 2V in correspondence with the reference mark on the head.
- Fit the pulley onto the camshaft.
- Assemble the counterweight with the corresponding fixing screw and tighten to the specified torque.

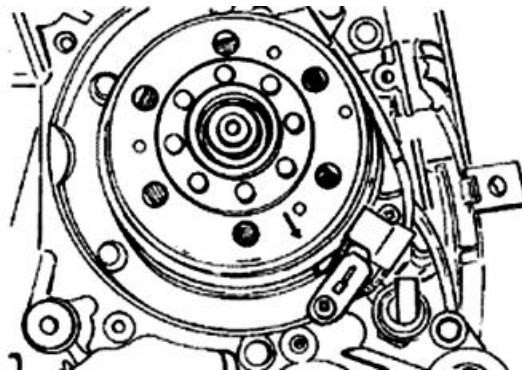

Locking torques (N*m)

Starter ground screw 7 ÷ 8.5

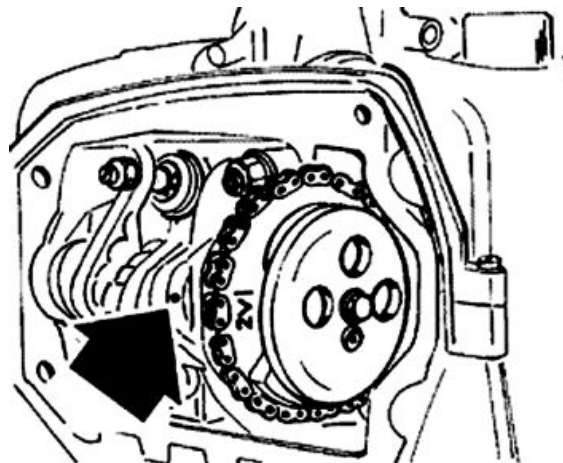

- Fit the end-stop ring on the automatic valve-lifter cam and fit the automatic valve-lifter cam to the cam shaft.
- Fit the automatic valve-lifter return spring.
- During this operation the spring must be loaded approximately 180°.

N.B.

GREASE THE END STOP RING TO PREVENT IT COMING OUT AND FALLING INTO THE ENGINE.

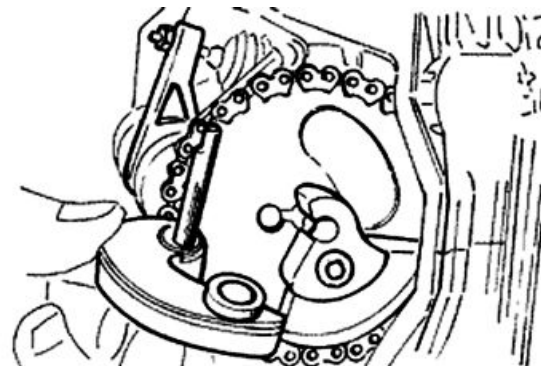

- Fit the automatic valve-lifter retaining dish, using the counterweight screw fastener as a reference.
- Tighten the clamping screw to the prescribed torque.

Locking torques (N*m)

Camshaft pulley screw 12 ÷ 14

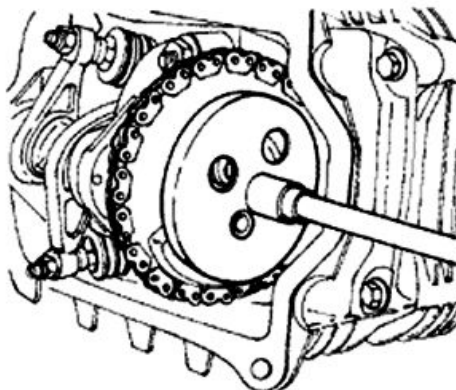

- Set the tensioner cursor in the rest position.
- Fit the chain tensioner on the cylinder, using a new gasket, and tight the two screws to the prescribed torque.

Locking torques (N*m)

Tightener screw: 5 - 6

- Insert the chain tensioning screw, together with the spring and washer, tightening it to the prescribed torque.

Locking torques (N*m)

Timing chain tensioner central screw 5 - 6

- Adjust valve clearance.
- Fit the spark plug.

Locking torques (N*m)

Ignition spark plug 12 ÷ 14

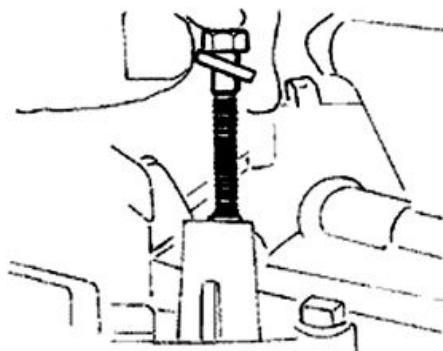

- Assemble the casing sealing gasket on the head. On the fitting direction, use the supplements on the timing side as reference.
- Assemble the screw fixing the housing to the crankcase to the specified torque and the 2 self-threading screws joining the half-shells.
- Take care that the gasket is well inserted in its housing during the assembly stage.
- Place the spark plug access cap.

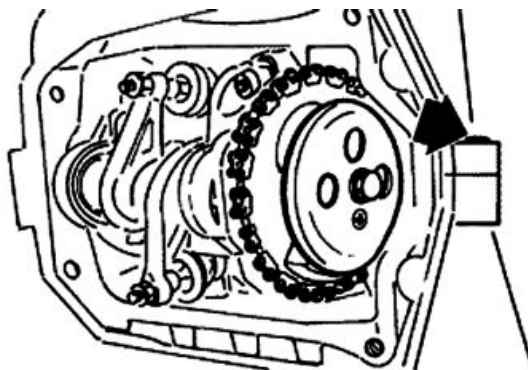

Locking torques (N*m)

Flywheel air manifold screw 3 ÷ 4

- Fit the inlet manifold and lock the 2 screws to the specified torque.
- Fit the carburettor onto the inlet manifold and lock the clamp

N.B.

FIT THE CARBURETTOR THROUGH THE SUPPLEMENT ON THE MANIFOLD.

Locking torques (N*m)

Head intake manifold screw 11 ÷ 13

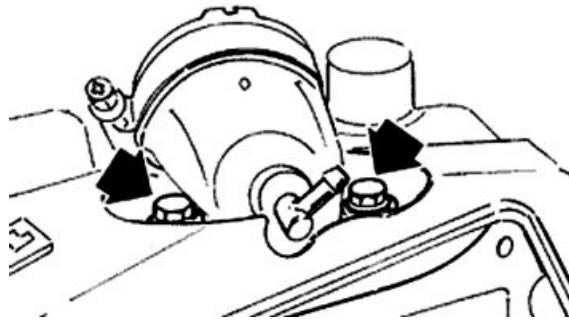

- Refit the cylinder head cover, tightening the 4 clamping screws to the prescribed torque.
- Refit the fan and the housing.
- Reassemble the oil pump control, the chain compartment cover, the by-pass and the oil sump as described in the lubrication chapter.
- Reassemble the driving pulley, the belt and the transmission cover as described in the transmission chapter.

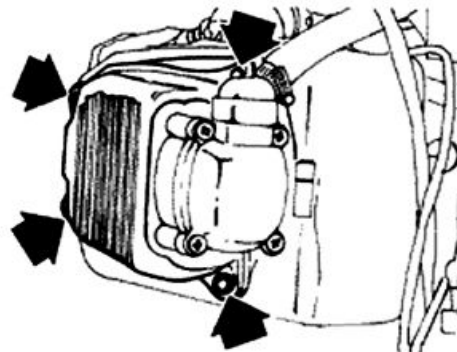
**Locking torques (N*m)**

Head cover screws 11 ÷ 13

Crankcase - crankshaft

- Precautionary remove the following units: transmission cover, driving pulley, driven pulley and belt, rear hub cover, gears, bearings and oil seals as described in the transmission chapter.
- Remove the oil sump, the by-pass, the chain compartment cover and the oil pump as in the lubrication chapter.
- Remove the flywheel cover, the fan, the flywheel and the stator as described in the magneto flywheel chapter.
- Remove the oil filter and the oil pressure bulb.
- Remove the cylinder-piston-head unit as described in the cylinder head timing system chapter.
- Remove the 2 retainers indicated in the figure and the starter motor.

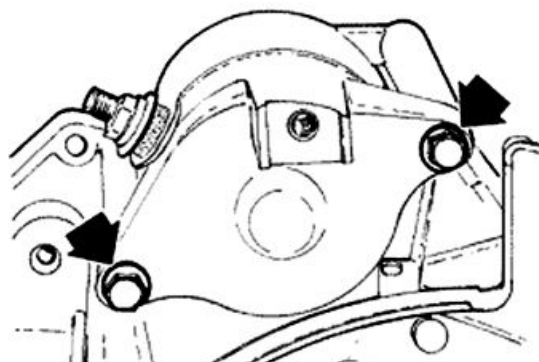

- Before opening the crankcase, it is advisable to check the axial clearance of the crankshaft. To do this, use a plate and a support with specific tool dial gauge.

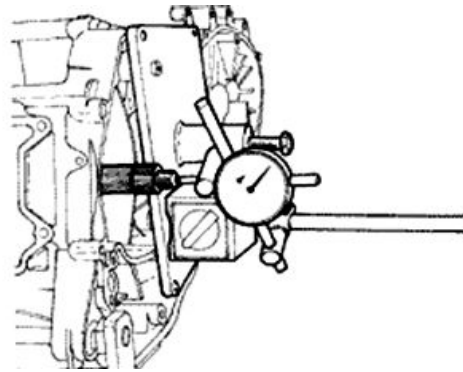

Specific tooling

020262Y Crankcase splitting strip

020335Y Magnetic support for dial gauge

Characteristic

Standard clearance

0.15 ÷ 0.40 mm

Splitting the crankcase halves

- Remove the 11 coupling screws to the crankcase.
 - Separate the crankcase while keeping the crankshaft in one of the two halves of the crankcase.
- Remove the crankshaft.

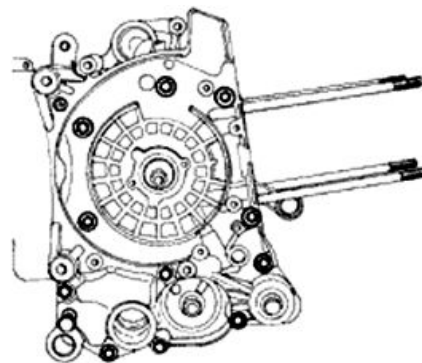

CAUTION

IF YOU FAIL TO DO THIS, THE CRANKSHAFT MIGHT ACCIDENTALLY FALL.

- Remove the coupling gasket of the crankcase halves.
- Remove the two screws and the internal cover shown in the diagram.

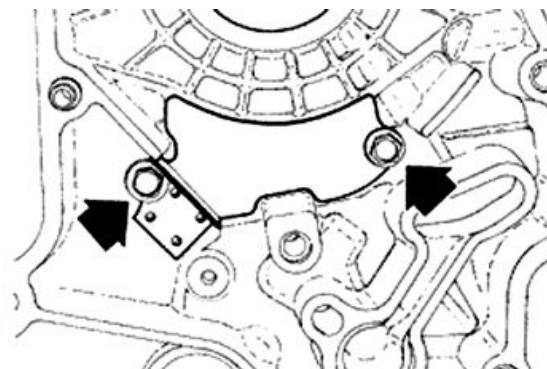

CAUTION

WHILE OPENING THE CRANKCASES AND REMOVING THE DRIVING SHAFT, CHECK THAT THE THREADED SHAFT ENDS DO NOT INTERFERE WITH THE MAIN BUSHINGS. FAILURE TO OBSERVE THIS PRECAUTION CAN DAMAGE THE MAIN BUSHINGS.

- Remove the oil guard on the flywheel side.
- Remove the oil filter fitting shown in the diagram

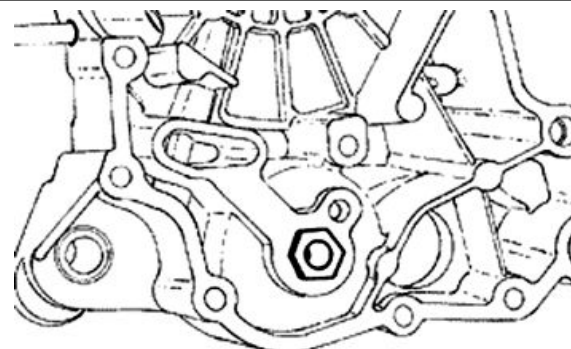

- Check the axial clearance on the connecting rod.

Characteristic
Standard clearance
 0.20 ÷ 0.50 mm

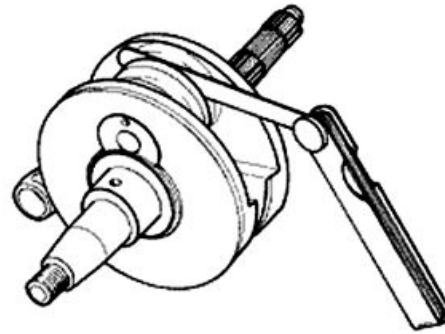

- Check the radial clearance on the connecting rod.
 -Check the surfaces that limit the axial free-play are not scored and measure the width of the crankshaft between these surfaces, as shown in the diagram.

CAUTION
 BE CAREFUL NOT TO LET THE MEASUREMENT BE AFFECTED BY THE UNIONS WITH THE CRANKSHAFT ENDS.

Characteristic
Standard clearance
 0.036 ÷ 0.054 mm

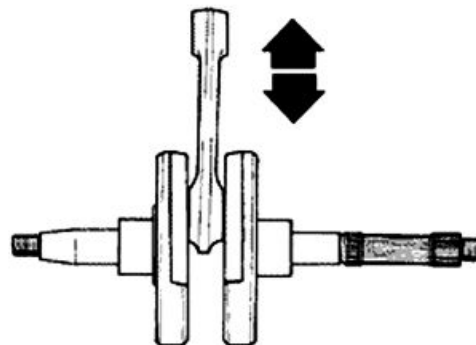

- If the axial clearance between crankshaft and crankcase is exceeding and the crankshaft does not have any defect, the problem must be due to either excessive wear or wrong machining on the crankcase.

CAUTION
 THE CRANKSHAFT CAN BE REUSED WHEN THE WIDTH IS WITHIN THE STANDARD VALUES AND THE SURFACES SHOW NO SIGNS OF SCORING.

Characteristic
Distance between the shoulders
 55.67 ÷ 55.85 mm

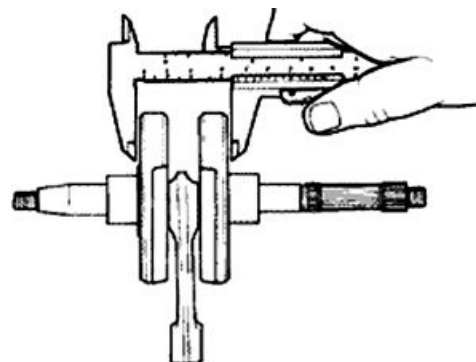

- Check the diameters of both the bearings of the crankshaft in accordance with the axes and surfaces shown in the figure. The half-shafts are classified in two categories Cat. 1 and Cat. 2 as shown the chart below.

STANDARD DIAMETER

Specification	Desc./Quantity
Category 1	28.998 ÷ 29.004
Class 2	28.004 ÷ 29.010

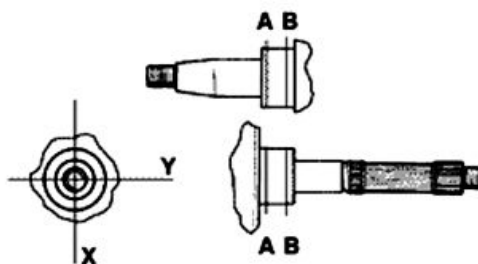

Inspecting the crankshaft alignment

To install the drive shaft on the support and to measure the misalignment in the 4 points indicated in figure.

- Check that the driving shaft cone, the tab seat, the oil seal capacity, the toothed gear and the threaded tangs are in good working order.
- In case of failures, replace the crankshaft.

The connecting rod head bushings cannot be replaced. For the same reason, the connecting rod may not be replaced and, when cleaning the crankshaft, be very careful that no impurities get in through the shaft's lubrication holes.

In order to prevent damaging the connecting rod bushings, do not attempt cleaning the lubrication duct with compressed air.

- Make sure that the 2 caps on the crankpin are properly fitted.
- A wrong installation of a cap can seriously affect the bushing lubrication pressure.

N.B.

THE MAIN BEARINGS ARE NOT GRINDABLE

Specific tooling

020074Y Support base for checking crankshaft alignment

Characteristic

Off-line maximum admitted

A = 0.15 mm

B = 0.01 mm

C = 0.01 mm

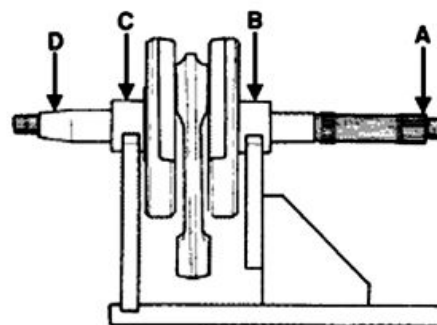

D = 0.10 mm

Inspecting the crankcase halves

- Before proceeding to check the crankcase halves, thoroughly clean the all surfaces and oil ducts.
- On the transmission side crankcase half, take particular care cleaning the housing and oil ducts for the following components: the oil pump, the oil by-pass valve, the main bushings and the cooling jet on the transmission side (see diagram).
- Take particular care, also, that there are no signs wear in the oil by-pass valve housing (see Chapter Lubrication), as this could prevent a good seal in the valve, which regulates the oil pressure.

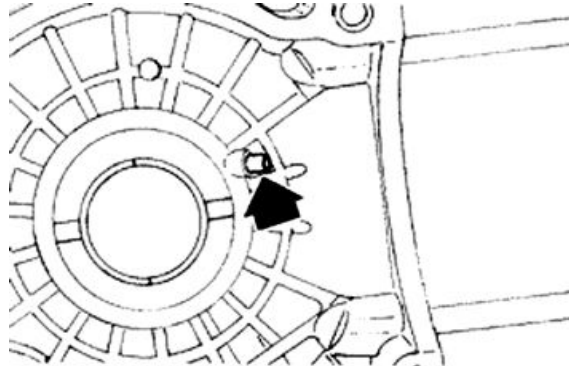

N.B.

THE JET IS FED THROUGH THE MAIN BUSHINGS. PROPER OPERATION OF THIS COMPONENT IMPROVES THE PISTON TOP COOLING. CLOGGING HAS EFFECTS THAT ARE DIFFICULT TO DETECT (PISTON TEMPERATURE INCREASE). FAILURE OR LEAK CAN CONSIDERABLY DECREASE THE MAIN BUSHING AND CONNECTING ROD LUBRICATION PRESSURE.

- On the flywheel side crankcase half, take particular care cleaning the oil ducts for the main bushings, the oil duct for the jet that lubricates the cylinder head and the oil drainage duct at the flywheel side oil seal.

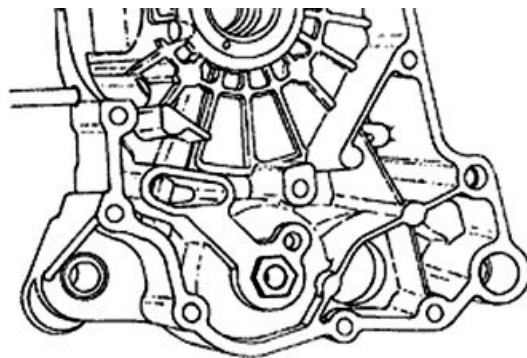

N.B.

THE HEAD LUBRICATION CHANNEL IS PROVIDED WITH A SHUTTER JET; THIS GIVES A "LOW PRESSURE" HEAD LUBRICATION; THIS CHOICE WAS MADE TO REDUCE THE OIL TEMPERATURE IN THE SUMP. THE JET CLOGGING IMPAIRS THE HEAD LUBRICATION AND THE TIMING MECHANISMS. A JET FAILURE CAUSES A DECREASE OF THE MAIN BUSHING AND CONNECTING ROD LUBRICATION PRESSURE.

- Inspect the mating surfaces on the crankcase halves for scratches or deformation, taking particular with the surfaces that mate with the cylinder and the mating surfaces between the crankcase halves.
- Defects in the crankcase coupling gasket or the surfaces indicated in the figure can cause a drop in the oil pressure and affect the lubricating pressure for the main bushings and the connecting rod.
- Check the main bearing seats that limit axial clearance in the crankshaft show no signs of wear. The dimension between these seats is measured by way of the procedure described previously for measuring the crankshaft axial clearance and dimensions.

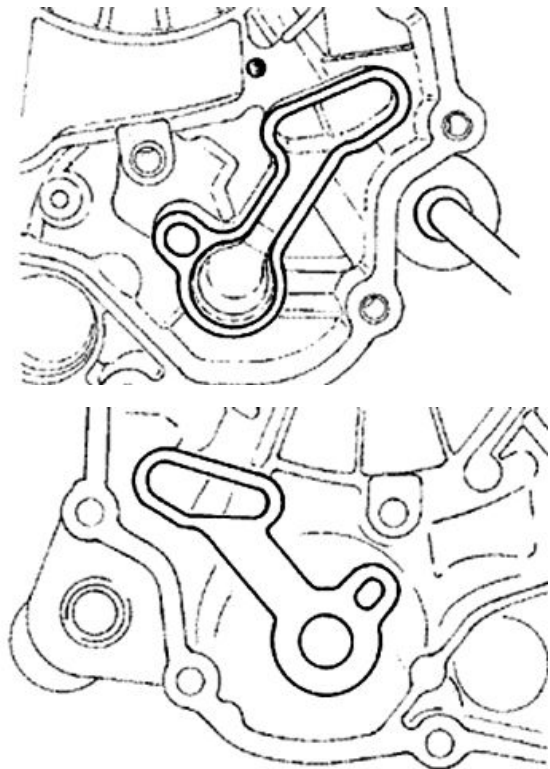

Inspecting the crankshaft plain bearings

- Check the inside diameter of the main bushings in the three directions indicated in the diagram.
 - Repeat the measurements for the other bushing half. see diagram.
 - The standard bushing diameter after driving is variable on the basis of a coupling selection.
 - The bushing housings in the crankcase are classified into 2 categories - Cat. 1 and Cat. 2 - just like those for the crankshaft.
- 3 - The main bushings are subdivided into 3 thickness categories; see the table below:

N.B.

DO NOT TAKE THE MEASUREMENT ON THE TWO HALF-SHELL COUPLING SURFACE SINCE THE ENDS ARE RELIEVED TO ALLOW BENDING DURING THE DRIVING OPERATION.

AXIAL CLEARANCE BETWEEN CRANKSHAFT AND CRANKSHAFT HALF-BEARINGS

Name	Description	Dimensions	Initials	Quantity
Crankshaft			Category 1	28.998 ÷ 29.004
Crankshaft			Class 2	29.004 ÷ 29.010
Crankcase			Category 1	32.953 ÷ 32.959
Crankcase			Category 2	32.959 ÷ 32.965
Crankshaft half-bearing			Category B - blue	1.973 ÷ 1.976
Crankshaft half-bearing			Type C - yellow	1.976 ÷ 1.979
Crankshaft half-bearing			Category E - green	1.979 ÷ 1.982
Crankshaft category 1 - Crankcase category 1			E - E	
Crankshaft category 1 - Crankcase category 2			C - C	
Crankshaft category 2 - Crankcase category 1			C - C	
Crankshaft category 2 - Crankcase category 2			B - B	

Crankshaft/crankcase axial clearance: $0.15 \div 0.40$

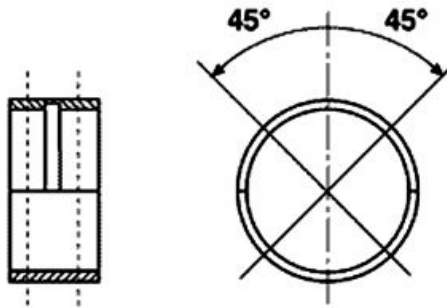

If the engine crankcase needs to be replaced and your crankshaft is Cat.1, order a crankcase prepared to house a Cat.1 crankshaft.

If the engine crankcase needs to be replaced and your crankshaft is Cat.2, order a crankcase prepared to house a Cat.2 crankshaft.

If the crankshaft needs to be replaced, just order one of a similar category.

Refitting the crankcase halves

- Fit the internal bulkhead by locking the two screws to the prescribed torque.

Locking torques (N*m)

Internal engine crankcase bulkhead (transmission-side half shaft) screws 4 ÷ 6

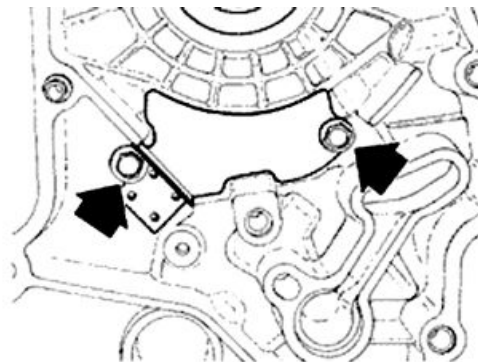

- Fit the oil filter joint and tighten it to the prescribed torque.

- Place a new gasket on one of the crankcase halves, preferably on the transmission side, together with the locating dowels.

Locking torques (N*m)

Oil filter on crankcase fitting 27 ÷ 33

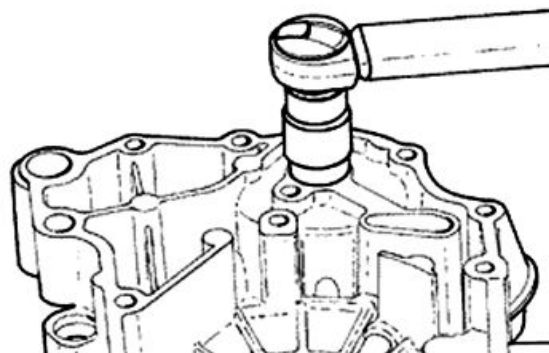

- Lubricate the main bushings and insert the crankshaft in the transmission side crankcase half.
- Reassemble the two crankcase halves.
- Fit the 11 screws and tighten them to the prescribed torque.

N.B.

WHEN FITTING THE HALF CASING AND THE CRANKSHAFT, TAKE CARE NOT TO DAMAGE THE SHAFT THREADED TANGS.

Locking torques (N*m)

Engine-crankcase coupling screws 11 ÷ 13

- Lubricate the flywheel oil seal.
- Use the appropriate tool to assemble the oil seal.
- Fit a new O-ring on the pre-filter and lubricate it.
- Insert the pre-filter with its cover on the engine and tighten to the prescribed torque.

N.B.

REMOVE ANY EXCESS FROM THE CRANKCASE COUPLING GASKET ON THE CYLINDER PLANE, TO ENSURE BETTER SEALING PERFORMANCE.

N.B.

FAILURE TO USE THE SPECIFIC TOOL CAN RESULT IN AN INCORRECT DEPTH POSITION AND AS A CONSEQUENCE IN INADEQUATE OIL SEALING.

Specific tooling

020425Y Punch for flywheel-side oil seal

Locking torques (N*m)

Pre-filter cap 24 ÷ 30

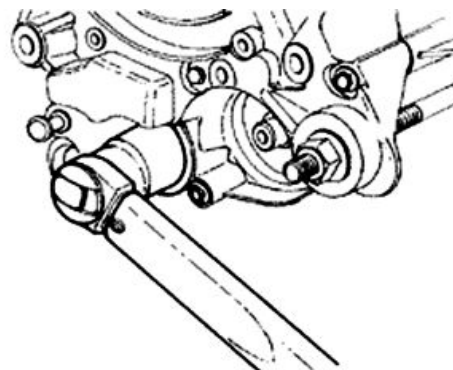
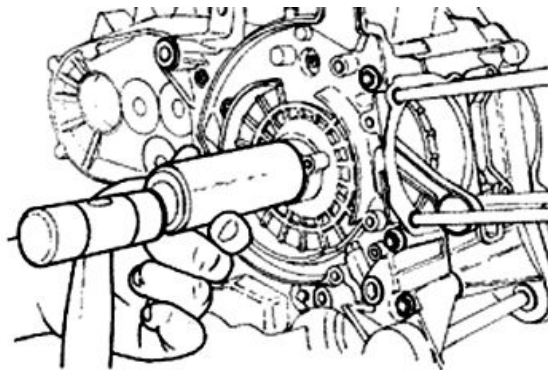

Lubrication

Conceptual diagrams

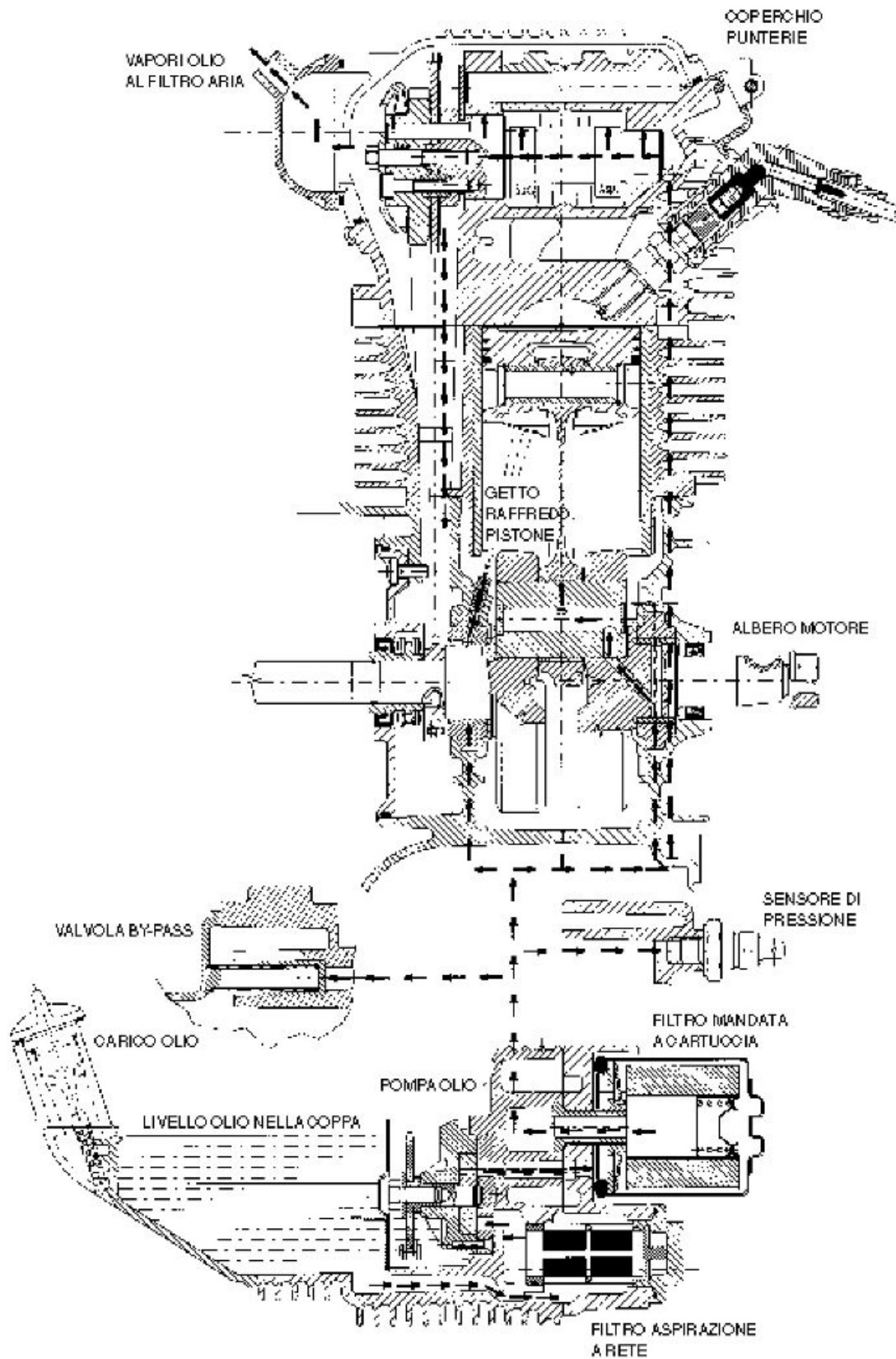

Oil pressure check

- After removing the fan cover housing as described in the "Flywheel" chapter, disconnect the electrical connection of the minimum oil pressure switch and then remove the switch.
- Fit the special tool.
- With the engine idling at 1650 rpm and the oil temperature at $\sim 90^{\circ}\text{C}$, check that the oil pressure is between $0.5 \div 1.2$ atm.
- With the engine idling at 6000 rpm and the oil temperature at $\sim 90^{\circ}\text{C}$, check that the oil pressure is between $3.2 \div 4.2$ atm.
- Remove the appropriate tools once the measurement is complete, refit the oil pressure switch and washer, tightening it to the prescribed torque and fit the fan cover.
- If the oil pressure is not within the specified limits, in the following order, check: the oil filter, the oil by-pass valve, the oil pump and the crankshaft seals.

N.B.

THE CHECK MUST BE CARRIED OUT WITH OIL AT THE CORRECT LEVEL AND WITH AN OIL FILTER IN GOOD CONDITION.

Specific tooling

020193Y Oil pressure gauge

020331Y Digital multimeter

Characteristic

Minimum pressure admitted

3.2 atm.

Locking torques (N*m)

Minimum oil pressure sensor $12 \div 14$

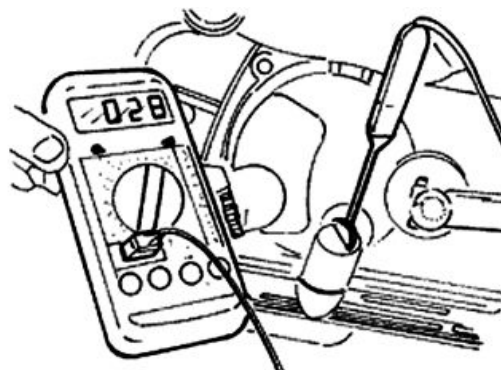
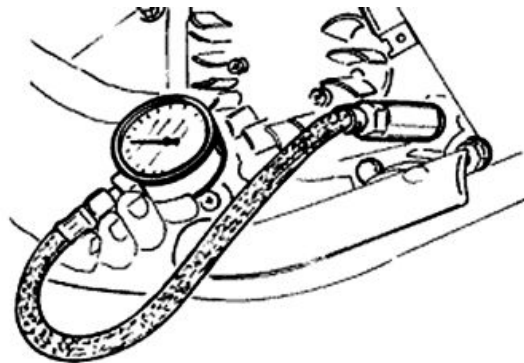

Crankshaft oil seals

Removal

- First remove the transmission cover and the complete driving pulley

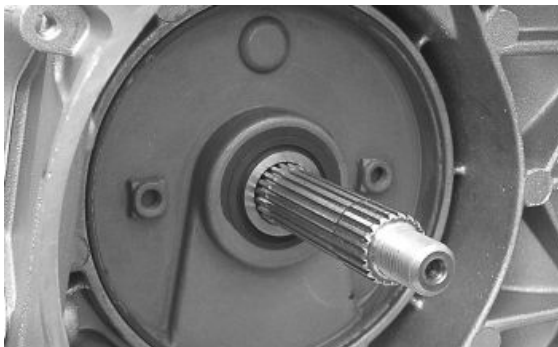

- Install the base of the appropriate tool on the oil guard using the screws provided.

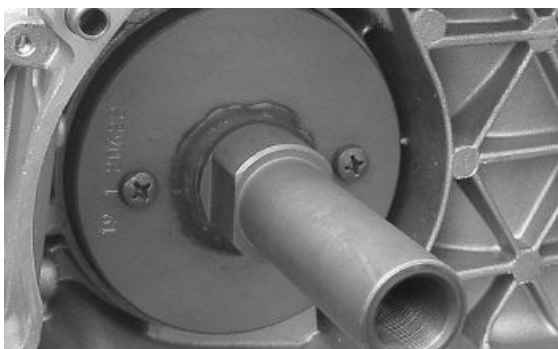

- Screw the threaded bar onto the base of the tool and extract the oil guard.

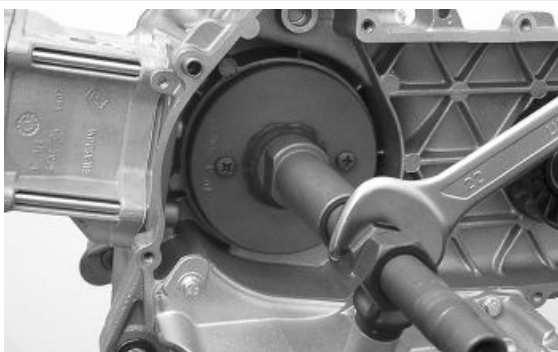

Specific tooling

020622Y Transmission-side oil guard punch

Refitting

- Prepare the new oil guard, lubricating the sealing lip. Warning: do not lubricate the surface for keying onto the engine crankcase.

CAUTION

DO NOT LUBRICATE THE SURFACE FOR KEYING ONTO THE ENGINE CRANKCASE.



- Preassemble the oil seal with the appropriate tool, positioning the screws
- Place the sheath over the crankshaft

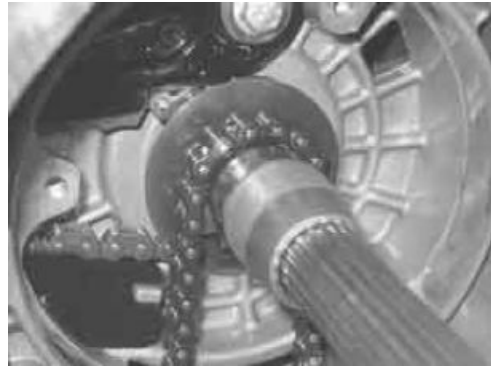

- Insert the tool with the oil seal on the crankshaft until it comes into contact with the crankcase

CAUTION

ORIENT THE OIL GUARD BY POSITIONING THE CHAIN HOUSING CHANNEL FACING DOWNWARDS. WHEN THE POSITION IS REACHED, DO NOT RETRACT THE OIL GUARD. FAILURE TO COMPLY WITH THIS RULE CAN CAUSE A WRONG POSITIONING OF THE OIL GUARD SHEATH.



- Orientate the oil guard by inserting the bracket which is part of the specific tool.



- Tighten the threaded bar onto the crankshaft as far as it will go.



- Use the nut to move the base of the tool until you can see end of the oil seal driving stroke



- Remove all of the tool components following the procedure in reverse order

CAUTION

FAILURE TO COMPLY WITH THIS ASSEMBLY PROCEDURE CAN SERIOUSLY DAMAGE THE ENGINE DUE TO THE WRONG TENSIONING OF THE OIL PUMP CONTROL CHAIN.

Assemble a new oil seal on the flywheel side using the specific tool as shown in the photograph

N.B.

FAILURE TO USE THE SPECIFIC TOOL CAN RESULT IN AN INCORRECT DEPTH POSITION AND AS A CONSEQUENCE IN INADEQUATE OIL SEALING.

Specific tooling

020425Y Punch for flywheel-side oil seal

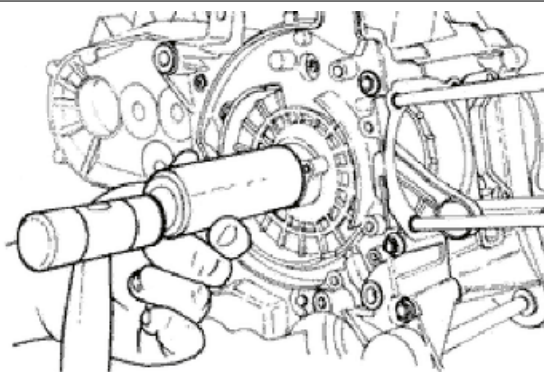

Oil pump

Removal

- Remove the cover of the pump control pulley using the two retainers, as shown in the figure.
- Block the rotation of the oil pump control pulley using a screwdriver inserted through one of its two holes.

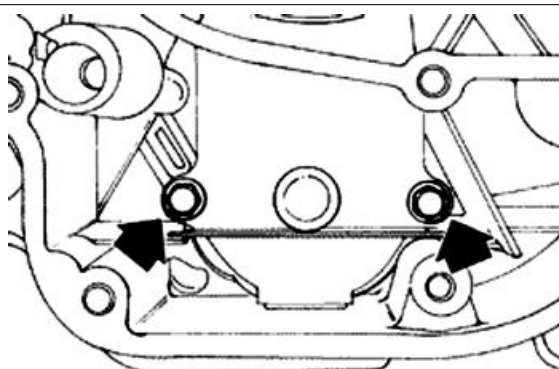

- Remove the central screw with Belleville washer, as shown in the diagram.
- Remove the chain with the pulley.
- Remove the crankshaft control pinion.

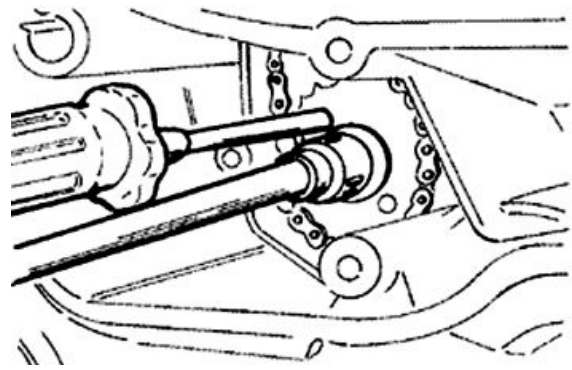

- Remove the oil pump acting on the 2 retainers as shown in the figure.
- Remove the oil pump seal.

IT IS ADVISABLE TO MARK THE CHAIN IN ORDER TO ENSURE THAT THE INITIAL DIRECTION OF ROTATION IS MAINTAINED.

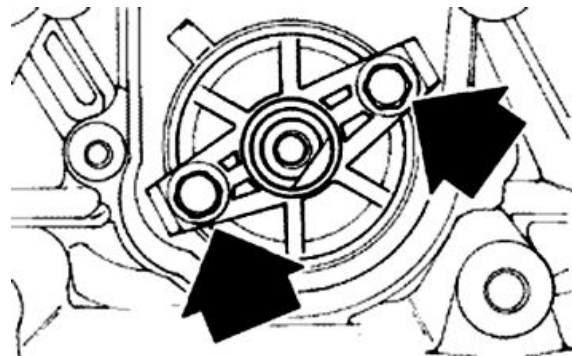

Inspection

- Remove the two screws and the oil pump cover.
- Remove the clip retaining the innermost rotor.
- Remove and wash the rotors thoroughly with petrol and compressed air.
- Reassemble the rotors in the pump body, keeping the two reference marks visible. Replace the clip.

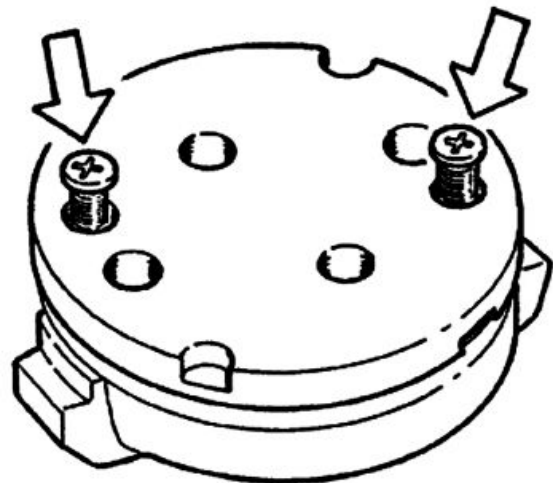

- Using a thickness gauge, check the distance between the rotors in the position shown in the figure.

Characteristic

Maximum clearance admitted

0.12 mm

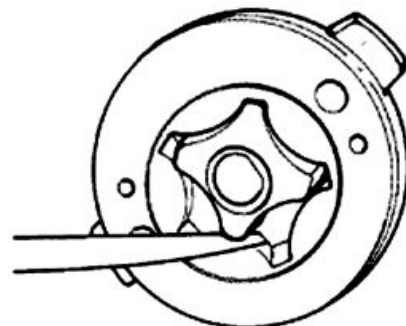

Measure the distance between the outer rotor and the pump body; see figure.

Characteristic

Admissible limit clearance:

0.20 mm

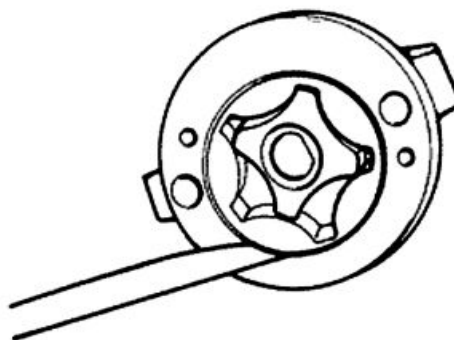

Check the axial clearance of the rotors with a trued bar as reference, as shown in the figure.

Characteristic

Limit values admitted:

0.09 mm

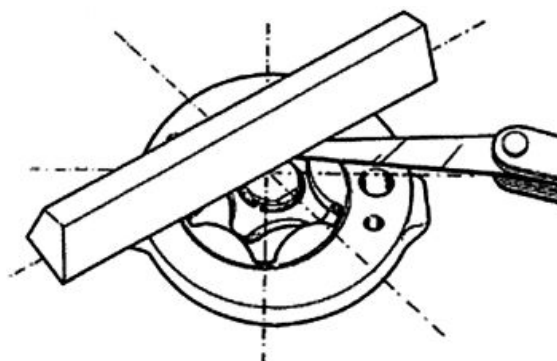

Refitting

- Place the circlip retaining the internal rotor.
- Tighten the two fixing screws of the pump cover to the prescribed torque.

Locking torques (N*m)

Oil pump cover screws 5 - 6

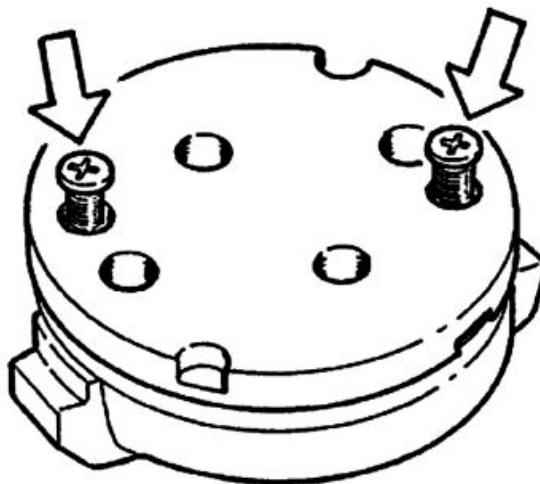

- Fit the oil pump seal.
- Fit the oil pump and tighten the two indicated screws to the prescribed torque.

Locking torques (N*m)

Oil pump screws 5 - 6

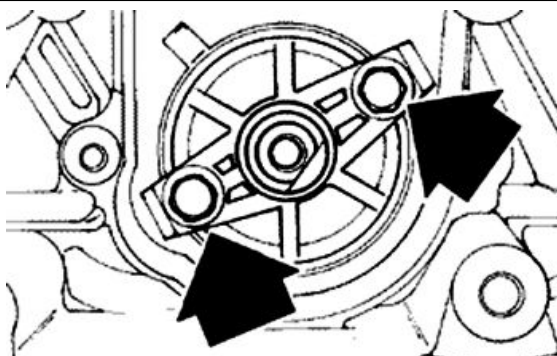

- Fit the crankshaft control pinion.
- Fit the control chain.
- Place the belleville washer and the nut and tighten them to the prescribed torque.

N.B.

FIT THE BELLEVILLE WASHER SO THAT ITS OUTER RIM TOUCHES THE PULLEY. MAKE SURE THAT THE PUMP TURNS FREELY.

Locking torques (N*m)

Pump control pulley screw 10 ÷ 14

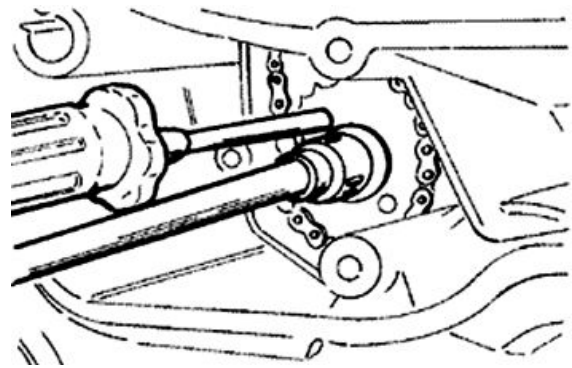

- Fit the pulley cover and tighten the two screws to the prescribed torque.

Locking torques (N*m)

Chain cover screws 4 ÷ 6

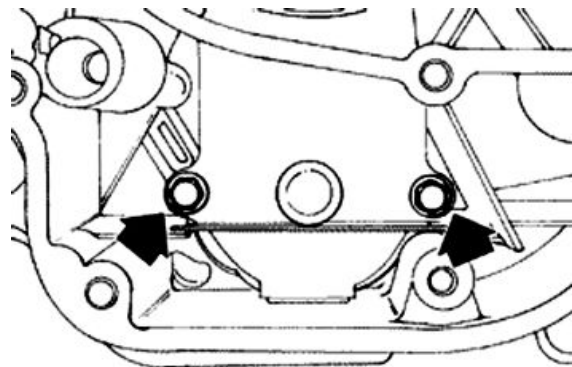
**Removing the oil sump**

- Remove the oil filler plug, the transmission cover, the complete drive pulley assembly with belt and the sprocket wheel, as described in the Transmission chapter.
- Drain the oil from the sump as described above.
- Remove the 7 screws indicated in the figure and the 2 rear brake transmission fixing brackets.
- Remove the spring, the by-pass piston and the gasket shown in the second image.

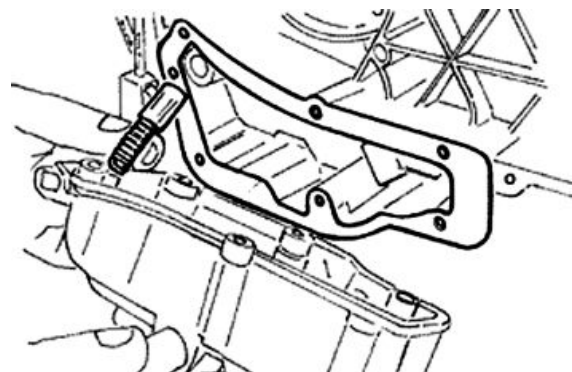
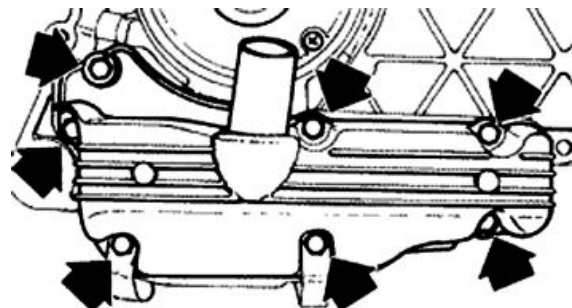

Inspecting the by-pass valve

- Check the unloaded spring length.
- Check that the small piston is not scored.
- Ensure that it slides freely on the crankcase and that it guarantees a good seal.
- If not, eliminate any impurities or replace defective parts.

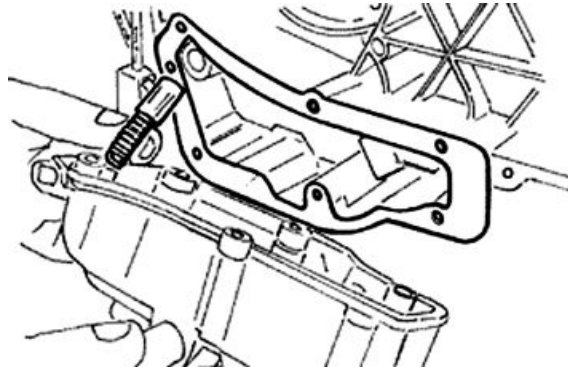

Characteristic

By-pass check up: Standard length

54.2 mm

Refitting the oil sump

- Refit the by-pass valve plunger in its housing.
- Insert the pressure-regulating spring.
- Fit a new sump seal.
- Refit the sump, taking care to locate the spring in the appropriate recess machined into the inside of the sump.
- Refit the rear brake transmission support brackets and the screws in the reverse order from which they were removed.
- Tighten the screws to the prescribed torque.
- Refit the drive pulley assembly, the drive belt, the sprocket wheel and the transmission cover, as described in the "Transmissions" chapter.
- **When testing the lubrication system, refer to the "Crankcase and Crankshaft" chapter, regarding lubrication of the crankshaft and connecting rod**

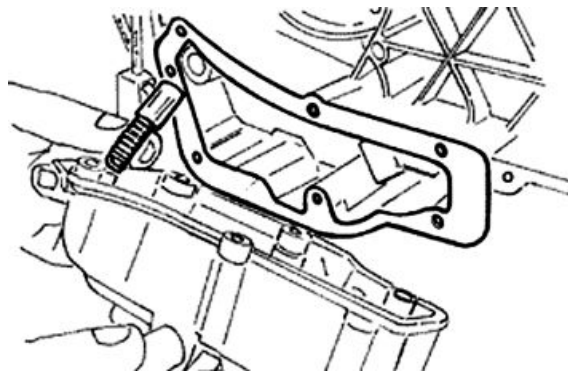

Locking torques (N*m)

Locking torque 11 ÷ 13

Fuel supply

To check the fuel supply, proceed as follows:

- TPS check

With the multimeter, check if the potentiometer is working correctly by placing the probes on both contacts indicated in the photograph .

With the throttle fully closed, the resistive value should respect the indicated value.

With throttle fully open, the resistive value should respect the indicated value.

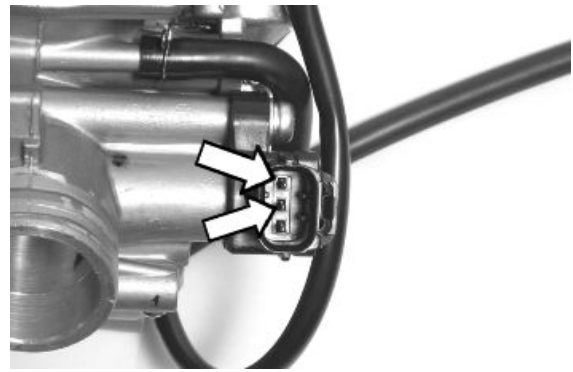
**Electric characteristic****Resistance with throttle fully closed**

1.3 K Ω

Resistance with throttle fully open

4.05 K Ω

- Fuel pump

- Make sure the fuel filters are not clogged and disconnect the return pipes from the carburettor pump.
- With the key switch set to «**ON**», start the vehicle.
- If fuel does not come out through the hoses, check the electric pump.

- Tank filter cleaning

- Completely empty the fuel tank.
- Remove the fuel outlet pipe.
- Loosen the clip and remove the cock.
- Clean the tank and the filter of the cock with a specific solvent.
- Refit the cock making sure that there is an O-Ring.
- Turn the cock to the direction it had before it was removed and block the clip.

**N.B.**

THE FILTER CAN BE UNSCREWED FROM THE COCK TO FACILITATE CLEANING.

Removing the carburettor

- To detach the carburettor from the engine, it is necessary to move the air filter and remove the throttle control transmission, the automatic starter connection, the clamps anchoring the carburettor to the filter housing and to the inlet manifold, the air delivery pipe to the diaphragm, the heater, the intake fitting and the TPS cable.



- Remove the heater

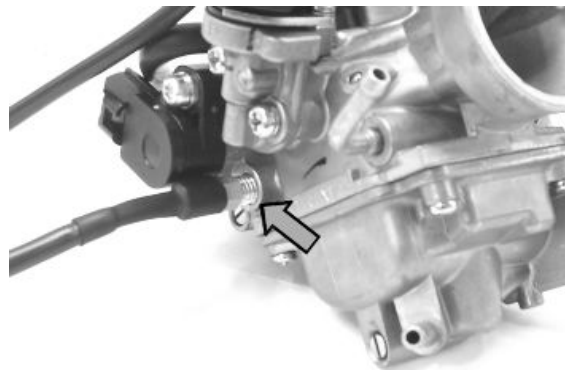

- Remove the protection, the bracket and the starter acting on the screw shown in the figure.



- Remove the 2 screws and the starter support with the gasket.



- Remove the 4 fixing screws shown in the figure and the vacuum chamber cover.

WARNING

DURING THE REMOVAL OF THE CARBURETTOR COVER TAKE SPECIAL CARE NOT TO RELEASE THE SPRING ACCIDENTALLY.



- Remove the vacuum valve together with the diaphragm.



- Unscrew the bayonet joint 1/8 of a turn and remove, take out the spring and vacuum valve needle

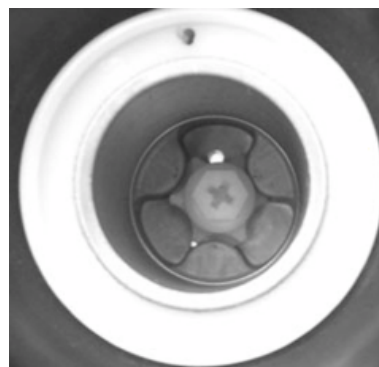

- Remove the 4 screws indicated in the figure.



- Remove the chamber with the accelerating pump, its control and gasket.



- Remove the oil pump seal.
- Remove the intake and outlet valves of the intake pump from the tank

N.B.

CAUTION, THE ACCELERATION PUMP VALVES ARE MADE UP OF NOZZLES, SPRING AND BALL.

N.B.

AVOID REMOVING THE PISTON OF THE PUMP AND ITS CONTROL.



Adequately support the carburetor and using a rod and hammer remove the float pin acting from the throttle control side.

- Remove the float and the plunger.
- Remove the maximum nozzle



-Remove the maximum nozzle.

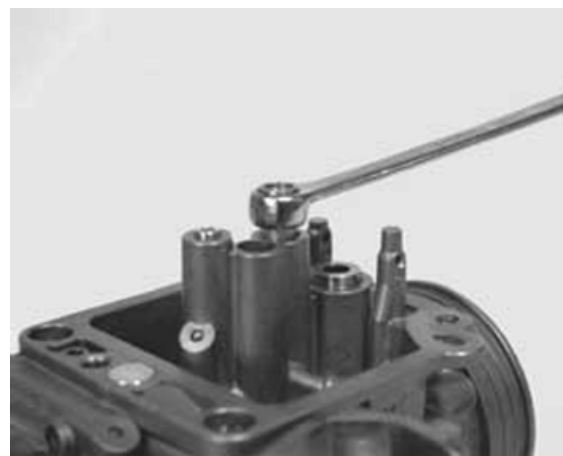

-Remove diffuser.

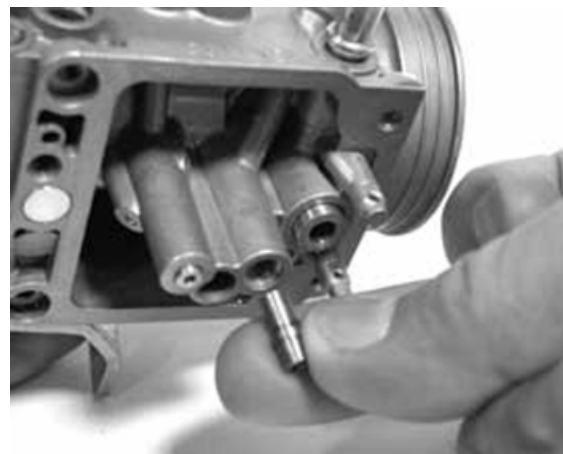

- Remove the sprayer.

N.B.

WHEN CLEANING THE CARBURETTOR BODY REMOVE THE SPRAYER TO AVOID LOSING PARTS. IF THE SPRAYER IS FORCED IN ITS HOUSING DO NOT ATTEMPT TO REMOVE IT AS THIS WILL ONLY DAMAGE IT.

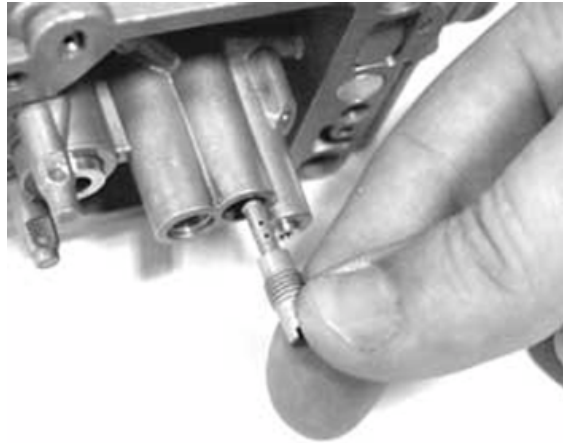

-Remove the minimum nozzle.

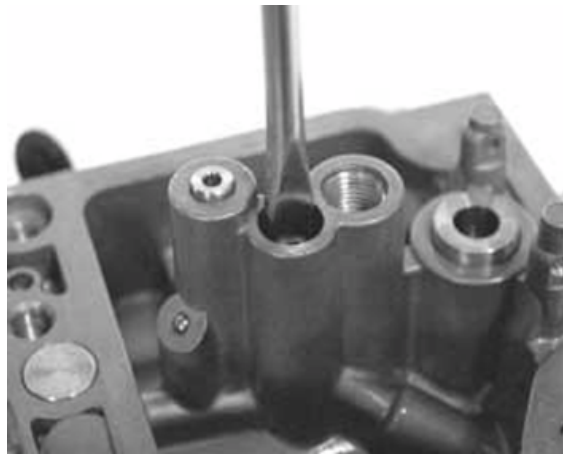

- Remove the minimum flow set screw and the spring.

CAUTION

DO NOT ATTEMPT REMOVING PARTS EMBEDDED IN THE CARBURETTOR BODY SUCH AS: FUEL SUPPLY PIPE, PLUNGER HOUSING, STARTER NOZZLE, PIT COVER FOR PROGRESSIONS AND INLET NOZZLE, MINIMUM AND MAXIMUM AIR GAUGE, THROTTLE VALVE CONTROL SHAFT. DO NOT REMOVE THROTTLE-SHAFT CONNECTION SCREWS. THE FIXING SCREWS ARE CAULKED AFTER ASSEMBLY AND THEIR REMOVAL DAMAGES THE SHAFT.



Refitting the carburettor

- Before refitting, wash the carburettor body accurately with petrol and compressed air.
- Pay special attention to the fuel supply pipe and the plunger seat.

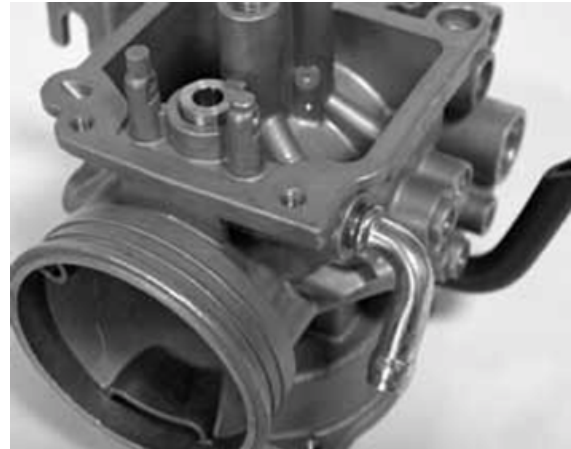

- For maximum circuit, check the air adjustment is correct as shown in the figure.

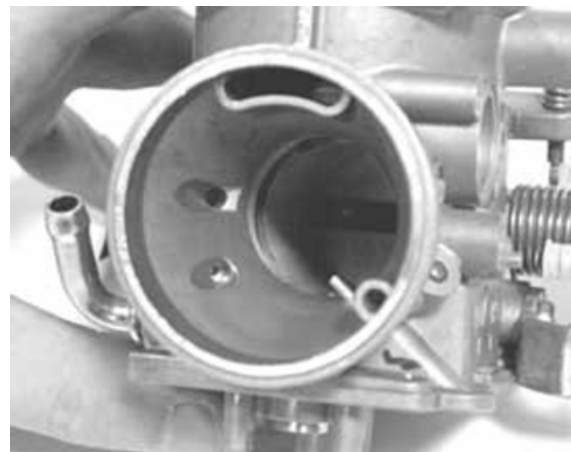

- For the minimum circuit, make sure the following points are properly cleaned: air gauging, outlet section controlled by flow screw, progression holes near the throttle valve.



- For the starter circuit, blow the connection pipe properly with the jet. This is necessary because the nozzle support hides other inaccessible internal calibrations.
- Blow the intake nozzle properly.

N.B.

THE ACCELERATION NOZZLE OUTLET IS EXTREMELY SMALL AND IS ORIENTED TO THE THROTTLE VALVE. NOZZLE INCORRECT ORIENTATION RESULTS IN INADEQUATE SPRAYING.

- Check that there are 5 closing ball joints for the operating pipes on the carburettor body.

- Check that the coupling surfaces, the tank and the diaphragm are not dented.
- Check that the depression valve housing pipe is not scratched.
- Check that the throttle valve and the shaft do not show abnormal wear.
- Check that the plunger seat does not show abnormal wear.
- Replace the carburettor in case of irregularities.
- Check that the return spring of the accelerating pump rocking lever is not deformed by over-stretching.

N.B.

TO AVOID DAMAGES, DO NOT INTRODUCE METAL OBJECTS IN THE ADJUSTED SECTIONS.

- Wash and blow the minimum nozzle properly and reassemble it.



- Properly wash and blow the components of the sprayer maximum circuit, the diffuser and the nozzle.
- Introduce the sprayer in the carburettor body with the shortest cylindrical part directed to the diffuser.
- Assemble the diffuser making sure the sprayer is being adequately inserted and lock it.
- Assemble the maximum nozzle.



- Check that the tapered pin does not show signs of wear on the sealing surfaces of the shock absorber pin and the return clamp.
- Replace the rod if worn out.



- Check that the float is not worn on the pin housing or on the contact plate with the plunger and that there are no fuel infiltration.
- Replace it in case of anomalies.

- Introduce the float with the rod on the fuel feeding tube side.

N.B.

INTRODUCE THE RETURN SPRING ON THE FLOAT PLATE ADEQUATELY

- Remove the drainage screw from the tank, wash and blow it properly and make sure the acceleration pump pipes are clean.

- Operate the acceleration pump piston repeatedly and blow with compressed air.

- Reassemble the acceleration pump valves following this order:

INTAKE VALVE (A)

- Spring
- Ball
- Nozzle

IN VALVE (M)

- Ball
- Spring
- Nozzle

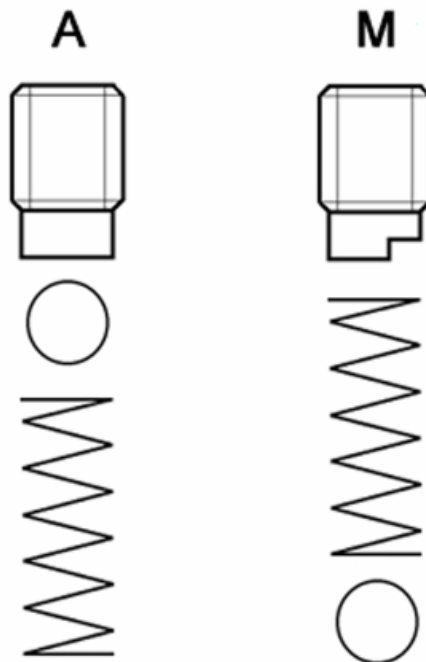

N.B.

THE IN VALVE NOZZLE, CORRESPONDING TO THE ACCELERATION PUMP, IS MILLED.

- Check the screw tightness introducing a small amount of fuel in the tank.

- Assemble a new gasket on the tank.

- Assemble the tank on the carburettor body fastening the 4 screws.

- Check that the control roller is free to rotate in its own seat.

N.B.

MAKE SURE THE TANK GASKET IS CORRECTLY INTRODUCED

N.B.

AVOID DEFORMING THE ACCELERATION PUMP CONTROL ROCKING LEVER.

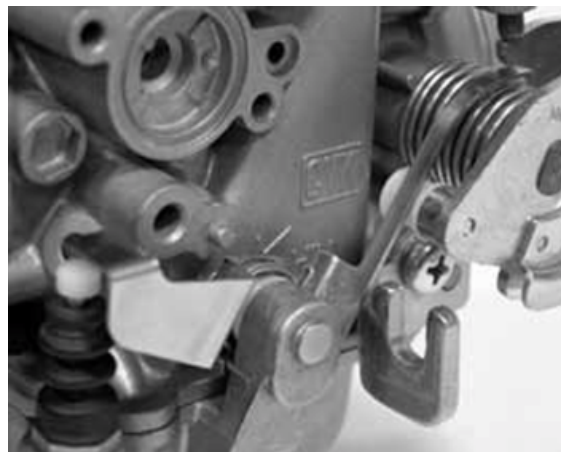

- Wash and blow the flow screw properly.

- Check that screw is not deformed and/or rusty.

- Assemble the spring on the screw.

- Screw the flow screw on the carburettor body.



- The screw final position should be determined by an exhaust fume analysis.
- Adjust the carburettor by turning the screw twice from the close position.

Level check

- Place the carburettor inclined as shown in the figure.



- Check that the float reference is parallel to the tank coupling surface
- If different positions are detected, change the plunger control metal plate direction to obtain the position described above.

Inspecting the valve and needle

- Check that the tapered pin of the vacuum valve does not show wear.
- Check that the depression valve does not show threads on the external surfaces.
- Check that the vacuum intake hole is not clogged.
- Check that the diaphragm is not damaged or has hardened, otherwise replacement the whole valve.
- Insert the tapered pin into the vacuum valve housing.
- Reassemble the vacuum valve on the carburettor body taking care that the tapered pin is inserted into the sprayer.



N.B.

THE VALVE CAN BE INSERTED IN ONLY ONE POSSIBLE POSITION.



- Reassemble the spring with the pin lock.
- Remove the cover of the vacuum chamber being careful to correctly insert the spring in its place on the cover.
- Tighten the screws.



- Wash and blow dry the filter sponge of the ambient pressure intake.



- Reassemble the filter with its clamp.



- Wash and blow dry the starter support.
- Assemble a new gasket on the carburettor body and tighten the 2 fixing screws.



Inspecting the automatic choke device

- Check that the automatic starter piston is not deformed or rusty.
- Check that the piston slides freely from the seat to the support.
- Check that the piston sealing gasket is not deformed.
- The starter must be more or less functional depending on the ambient temperature.
- Measure the protrusion of the piston as shown in the figure and check its corresponding value.
- Make sure that the starter is adjusted for the ambient temperature.
- The starter should disconnect progressively by means of electric heating.
- Check the starter resistance when adjusted to the ambient temperature.



With a 12V battery power the automatic starter and check that the piston protrudes as much as possible.

- The correct warm up time depends on the ambient temperature.
- If protrusion, resistance or timing values are different from the ones prescribed, replace the starter.
- Assemble the starter to the carburettor being careful to position the O-Ring correctly, insert the plate with the machined side contacting the starter, tighten the fixing screws.
- Position the starter as shown in the figure.
- Assemble the protection casing.

N.B.

TO CARRY OUT THIS CHECK PAY SPECIAL ATTENTION NOT TO GENERATE SHORT CIRCUITS USE A CABLE SECTION WITH A TERMINAL SUITABLE TO BE CONNECTED TO THE STARTER.

Characteristic

Starter pin travel

10 mm (at 24°)

Starter resistance

20 Ohm (at 24°)

Check the automatic starter: Keihin maximum time

5 min

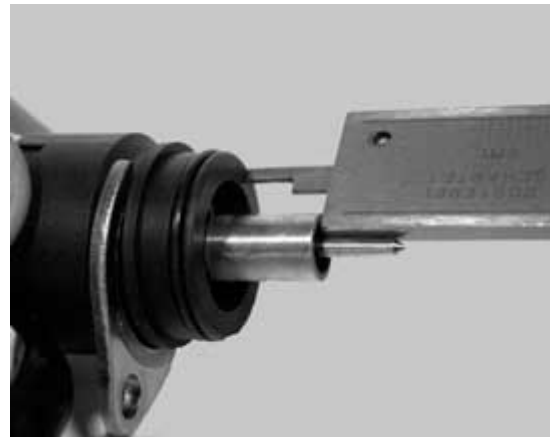

Adjusting the idle

- The engine does not require frequent idle speed adjustments, but it is essential to strictly follow certain rules when adjusting the idle speed.
- Before adjusting the carburettor make sure to respect the lubrication requirements, valve clearance, and complying timing, spark plug should be in optimum conditions, air filter clean and sealed, and the exhaust system tight.
- Warm up the engine by running it at least 5 minutes at approximately 50 kph.
- Connect a millimetre thermometer (020331y) on the sump, using a cover with oil expressly prepared for probes.
- Start the engine and before adjusting the idle speed, make sure that the oil temperature is between 70÷80 °C.
- Using the rpm indicator of the analyser or an independent one (020332y), adjust the idle set screw until 1600 ÷ 1700 rpm is obtained.

N.B.

THE WASTED SPARK IGNITION SYSTEM OFFERS REMARKABLE POWER. READINGS MAY NOT BE ACCURATE IF INADEQUATE RPM INDICATORS ARE USED. CORRECT COUPLING OF THE RPM INDICATOR WILL BE INDICATED WHEN IT CAN READ RPM OVER 6000 ÷ 8000

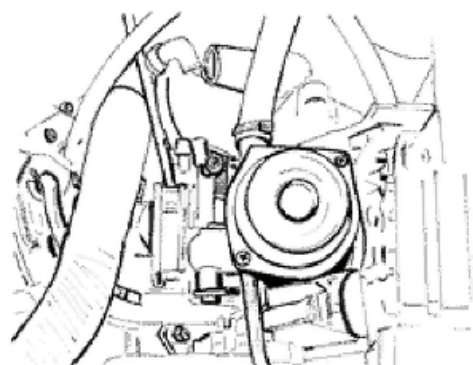
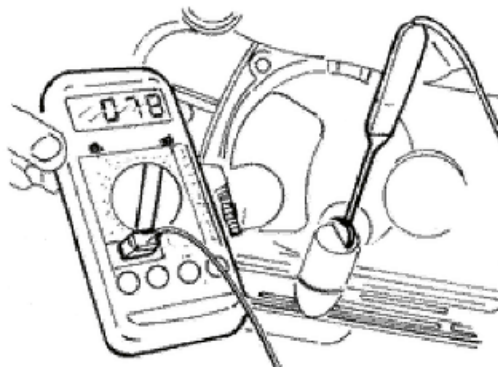

INDEX OF TOPICS

SSUSPENSIONS

SUSP

Front suspension

This section is devoted to operations that can be carried out on the suspension.

Front

Removing the front wheel

- Support the scooter adequately.
- Loosen the five screws fixing the wheel to the hub.

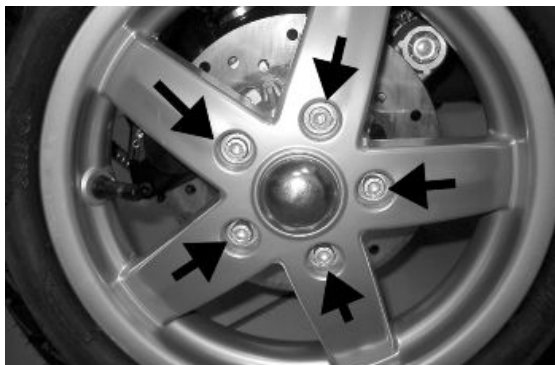

Front wheel hub overhaul

- Support the scooter adequately.
- Remove the front wheel.
- Remove the front calliper.
- Remove the cotter pin and remove the cap.

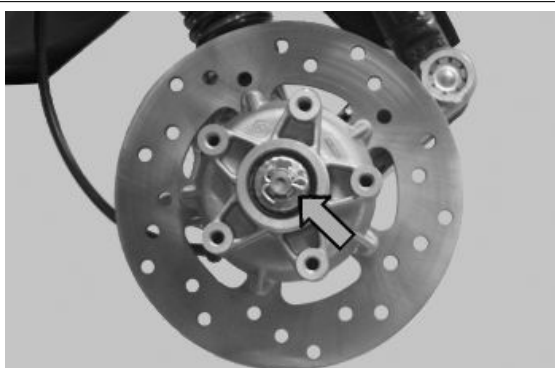

- Unscrew the nut fixing the front wheel hub.



- Remove the wheel hub.

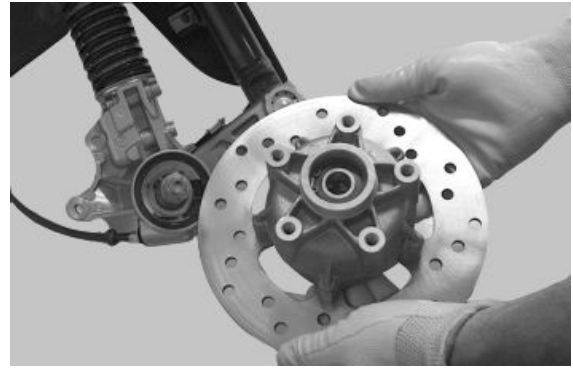

- Remove the ball bearing check seeger ring indicated in the photograph



Extract the ball bearing using the specific tool

Specific tooling

001467Y014 Pliers to extract \varnothing 15-mm bearings

001467Y017 Bell for bearings, OD 39 mm



- Remove the oil seal on the roller bearing side using a screwdriver.

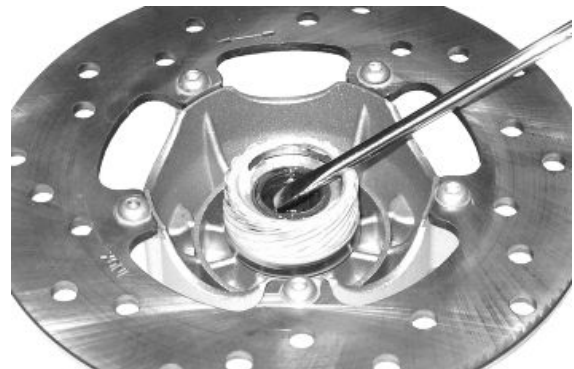

- Remove the roller bearing using the specific tool

Specific tooling

020376Y Adaptor handle

020456Y Ø 24 mm adaptor

020363Y 20 mm guide



- Heat the roller bearing seat with a heat gun
- Use the specific tool to introduce and push the bearing until it stops, with the shielded side facing out
- Refit the ball bearing check seeger ring

Specific tooling

020151Y Air heater

020376Y Adaptor handle

020357Y 32 x 35 mm adaptor

020412Y 15 mm guide



- Use the specific tool to fit and push the roller casing until it stops
- Refit the oil seal on the roller bearing side
- Lubricate the area between the roller bearing and the ball bearing

Specific tooling

020038Y Punch

Recommended products

AGIP GREASE MU3 Grease for odometer transmission gear case

Soap-based lithium grease with NLGI 3; ISO-L-XBCHA3, DIN K3K-20

- To refit, follow the removal steps but in reverse order; be careful to tighten to the prescribed torque.

Locking torques (N*m)

Front wheel axle nut 75 ÷ 90



Refitting the front wheel

- Upon refitting, tighten the five screws to the prescribed torque.

Locking torques (N*m)

Wheel rim screws 20 ÷ 25

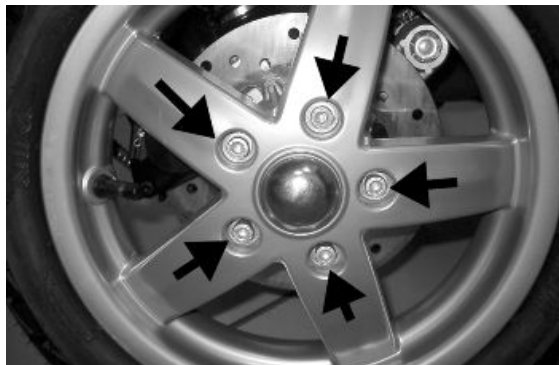

Handlebar

Removal

Remove the handlebar cover before carrying out this operation,.

- After removing the transmissions and disconnecting the electrical terminals, remove the terminal fixing the handlebar to the steering.
- Check all components and replace faulty parts.

N.B.

IF THE HANDLEBAR IS BEING REMOVED TO REMOVE THE STEERING, TILT THE HANDLEBAR FORWARD TO AVOIDING DAMAGING THE TRANSMISSIONS.

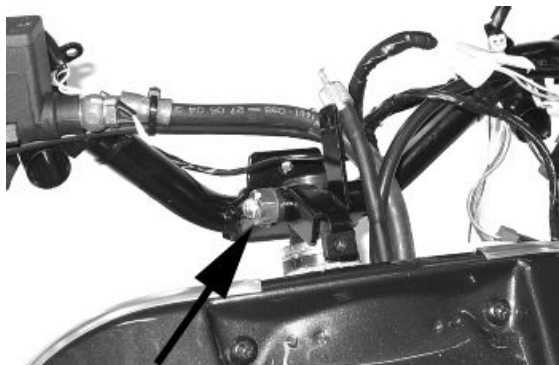

Refitting

Carry out the operations in the reverse order to the removal, observing the prescribed tightening torque.

Locking torques (N*m)

Handlebar lock nut 45 ÷ 50

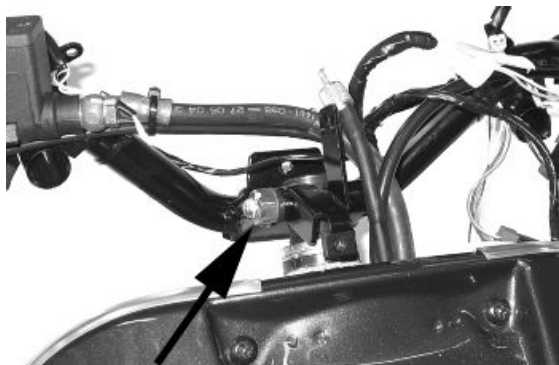

Steering column

Removal

After removing the upper seat, lean the vehicle on one side and extract the steering tube completely from the fork.

Specific tooling

020055Y Wrench for steering tube ring nut



Overhaul

Servicing the front suspension-steering assembly, described below, deals mainly with replacing parts (pin- NADELLA roller bushings - sealing rings unit and dust guard) which connect the steering tube to the front wheel holder swinging hub.

N.B.

BEFORE PROCEEDING WITH THE DESCRIBED SERVICE, CHECK THAT THE STEERING TUBE AND THE WHEEL HOLDER HUB ARE IN EXCELLENT CONDITIONS: ONLY THEN IS THE SERVICE JUSTIFIABLE. MOREOVER, REMEMBER THE STEERING TUBE SHOULD BE REPLACED WITH A NEW ONE WHEN DEFORMED.

a = Ø 12 Punch

b = Sharp-edged end

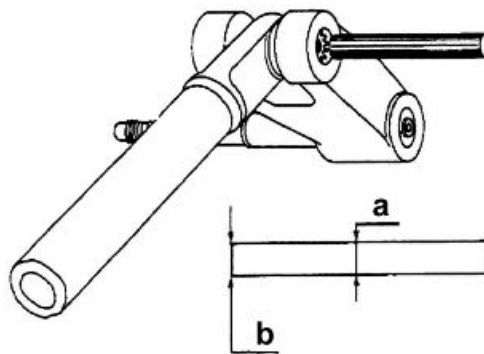

Use a suitable punch with the dimensions indicated on the figure; hit with a mallet until the wedging washer is crushed and then extract it with the help of a pointed end.

Repeat the operation for the second washer using the punch on the side opposite to the one shown in the figure.

Use the tool fitted with part 1 as shown in the figure and move the tool handgrip until the pin and the NADELLA are simultaneously ejected in the direction opposite the tool thrusting force.

After removing the pin and the first NADELLA, the swinging hub gets detached from the steering tube.

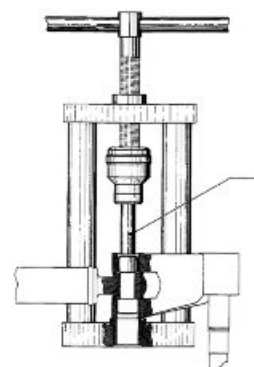

To remove the second NADELLA, use the tool fitted with part 2 instead of part 1, on the side opposite the one shown in the figure.

N.B.

DURING THE REMOVAL OPERATIONS DESCRIBED ABOVE, THE ROLLER BUSHINGS ARE DESTROYED WHEN THE EXTRACTOR IS USED. UPON REFITTING, IT IS THEREFORE NECESSARY TO USE NEW BUSHINGS AS WELL AS A NEW PIN, NEW SEALING RINGS AND DUST GUARDS.

Specific tooling**020021Y Front suspension service tool**

Connect the swinging hub to the steering tube with the guiding pin.

- Use the tool fitted with part 3 on the stem and part 4 .

Lubricate the pin with recommended grease and insert it temporarily on the swinging hub, move the tool handgrip until part 3 is fully inserted on the steering tube.

After fitting the pin, insert the two spacers, slightly hitting them with the mallet.

N.B.

BEFORE PROCEEDING WITH THE DESCRIBED FITTING, PLACE THE TWO DUST GUARD RINGS ON THE SWINGING HUB AS SHOWN IN THE FIGURE.

Specific tooling**020021Y Front suspension service tool****Recommended products****AGIP GREASE SM 2 Grease for odometer transmission gear case**

Lithium grease with NLGI 2 molybdenum disulfide; ISO-L-XBCHB2, DIN KF2K-20

Insert the sealing ring on the pin and the roller bushing with its wedging washer at the same time.

- Remove the tool and the part 5 (guide), which has been partially ejected during the previous pin fitting phase, and leave part 4 always fitted.

- Replace part 3 with part 16 (on the stem).

- By moving the tool handgrip, push the wedging washer - roller bushing - seal ring unit, placing part 16 until it stops on the swinging hub.

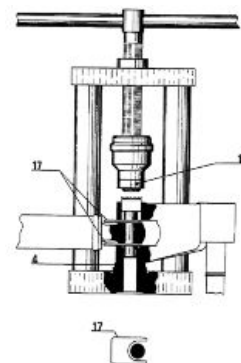
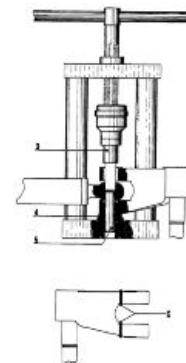

- Repeat the above operation using the tool with part 16 and part 22, instead of part 4, always fitted to the stem, on the side opposite that indicated in the figure to fit the second wedging washer - roller bushing - sealing ring unit.

WARNING

BEFORE PROCEEDING WITH THE DESCRIBED PRE-FITTING, DIP THE SEALING RINGS IN MINERAL OIL AND THE "NADELLA" ROLLER BUSHINGS (PREVIOUSLY WASHED IN PURE PETROL OR NEUTRAL PETROLEUM TO ELIMINATE THE ANTIRUST PROTECTION), HALF-FILLED WITH GREASE.

Specific tooling

020021Y Front suspension service tool

Recommended products

AGIP GREASE MU3 Grease for odometer transmission gear case

Soap-based lithium grease with NLGI 3; ISO-L-XBCHA3, DIN K3K-20

- Use the tool fitted with part 20 on its stem and part 21 on the tool base as shown in the figure.
- By moving the tool handgrip, push the two NADELLA bushings until their internal bottoms make contact with the pin end.
- Use the tool fitted with parts 3 and 4 to fit the pin, and press moving the tool handgrip, until wedging the washers on the swinging hub.
- Now, remove the two spacers (parts 17 and 16) and, once the space between the NADELLAs - steering tube and swinging hub - has been fully filled with grease, move the dust guard rings until they are placed in that space.
- By wedging the washers as described above, the front suspension unit refitting stage is finished.

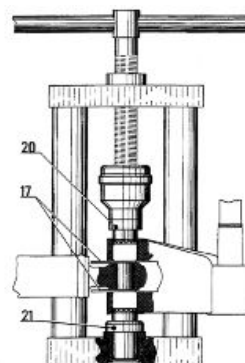

Recommended products

AGIP GREASE MU3 Grease for odometer transmission gear case

Soap-based lithium grease with NLGI 3; ISO-L-XBCHA3, DIN K3K-20

Refitting

CAUTION

USE NEW ROLLER CASINGS, PIN, SEALING RINGS AND DUST GUARDS FOR REFITTING.

When fitting the fork, lubricate with the steering bearing tracks with the recommended grease.

Tighten the lower ring nut "A" and the upper ring nut "B" to the specified torque

Recommended products

AGIP GREASE PV2 Grease for the steering bearings, pin seats and swinging arm

White anhydrous-calcium based grease to protect roller bearings; temperature range between -20 C and +120 C; NLGI 2; ISO-L-XBCIB2.

Locking torques (N*m)

Steering lower ring nut 8 ÷ 10 Steering upper ring nut 35 ÷ 40

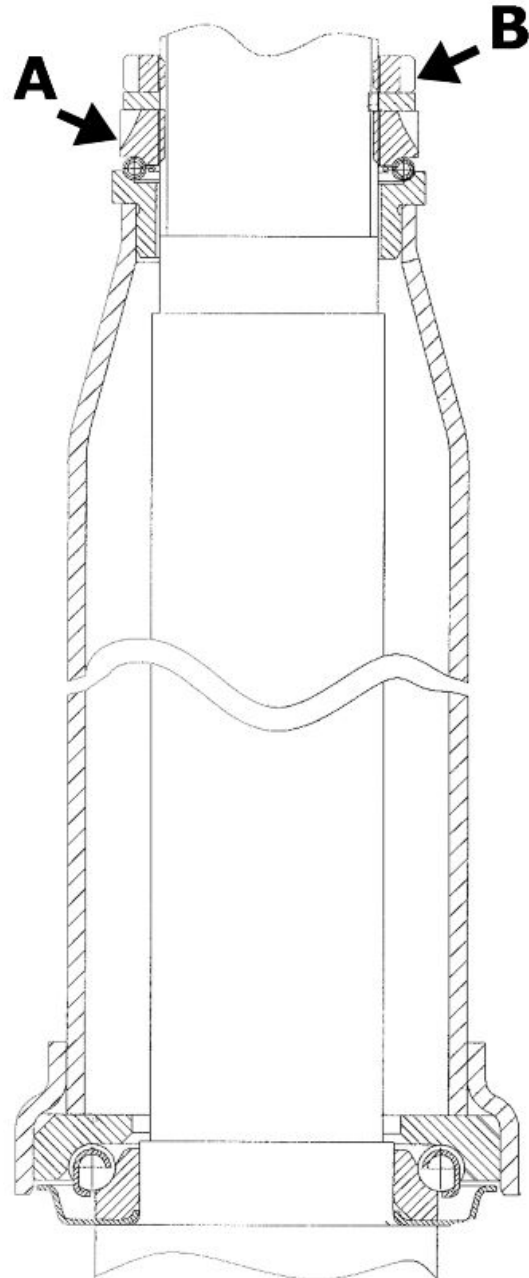

Front shock absorber

Removal

- Support the scooter adequately.
- Remove the wheel hub.
- Loosen the shock absorber lower clamps and remove the brake calliper shock absorber support.

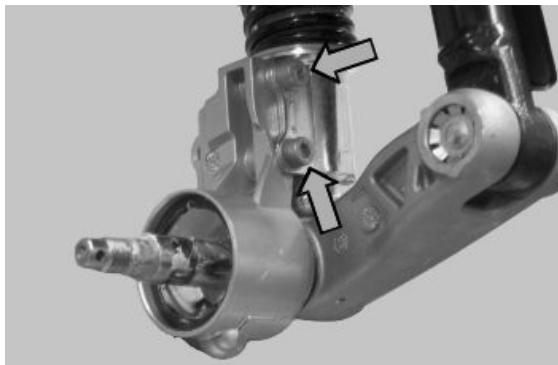

- Loosen the screws fixing the front brake pipe retainer clamp and the odometer cable in order to reach the upper clamps.

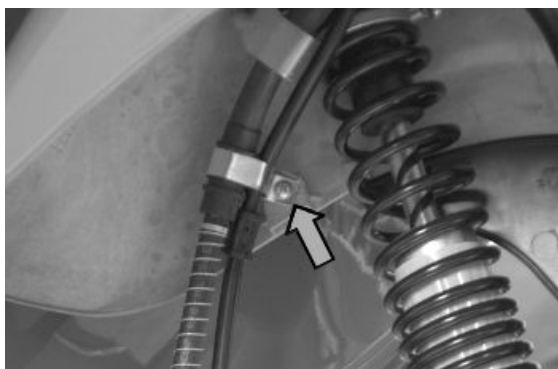

- Unscrew the upper fixing nuts.

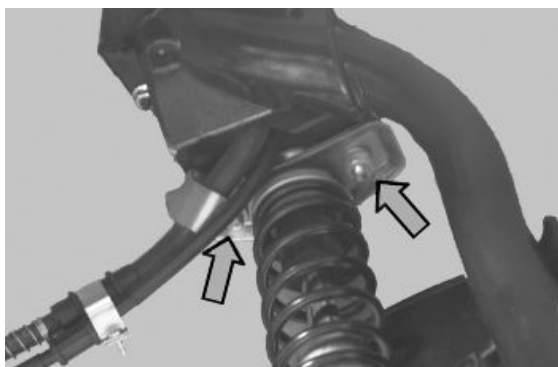

- Remove the front shock absorber.



Refitting

To refit, carry out the removal operations in reverse order, observing the prescribed tightening torques.

Locking torques (N*m)

shock absorber lower clamp 20 - 27 shock absorber upper clamp 20 ÷ 30

Shock-absorber - calliper bracket

Removal

- Remove the front wheel hub with the brake disc
- Remove the front shock absorber lower clamps



- Remove the bracket locking seeger ring
- Unscrew the bracket



- Before refitting the bracket in the wheel axle, place the O-ring as shown in the photograph so that it is correctly placed after fitting the bracket.
- Refit the washer and the Seeger ring.
- Refit the lower screws fixing the shock absorber to the bracket and tighten at the prescribed torque



Locking torques (N*m)

Lower shock absorber clamp 20 ÷ 27

Overhaul

- The bracket for the shock absorber -calliper attachment has two roller bearings separated one from the other as shown in the photograph



- Remove the two roller bearings from the bracket with the specific tool operating on the shock absorber attachment side as shown in the photograph



Specific tooling

020376Y Adaptor handle

020441Y 26 x 28 mm adaptor

020365Y 22 mm guide

- Remove the oil seal on the wheel hub side with the screwdriver as shown in the photograph



- Suitably hold the brake calliper - shock absorber attachment bracket

- Fit a new oil seal and move it until it stops using the specific tool

Specific tooling

020376Y Adaptor handle

020360Y Adaptor 52 x 55 mm



- Assemble a new roller bearing on the shock absorber side and move it until it stops using the specific tool

Specific tooling

020036Y Punch



- Suitably hold the brake calliper - shock absorber attachment bracket

- Assemble a new roller bearing on the wheel hub side and move it until it stops using the specific tool

Specific tooling

020037Y Punch



Refitting

- Refit the parts in reverse order of the removal operation.

CAUTION

BEFORE CARRYING OUT REFITTING OPERATIONS IN THE AREAS MARKED WITH AN ASTERISK, LUBRICATE THEM WITH THE RECOMMENDED PRODUCT

Specific tooling

020036Y Punch

020037Y Punch

Recommended products

AGIP GREASE PV2 Grease for control levers on the engine

White anhydrous-calcium based grease to protect roller bearings; temperature range between -20 °C and +120 °C; NLGI 2; ISO-L-XBCIB2

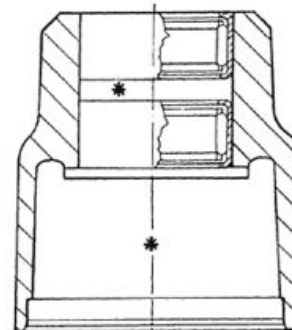

Steering bearing

Removal

- Use the specific tool both to remove the lower seat of the upper bearing and to remove the upper seat of the lower bearing fitted on the chassis.

N.B.

TO REMOVE THE LOWER SEAT OF THE LOWER STEERING BEARING JUST USE A SCREW-DRIVER AS A LEVER BETWEEN THE SEATING AND THE SLEEVE.

Specific tooling

020004Y Punch for removing fifth wheels from headstock

- Remove the fifth wheel fitting and the dust guard on the steering tube as shown in figure, using the specific tool. Proceed giving a few taps with the mallet.



Specific tooling

020004Y Punch for removing fifth wheels from headstock

- Refit the fifth wheel fitting and the dust guard on the steering tube until they stop, using the specific tool.



Specific tooling

006029Y Punch for fitting fifth wheel seat on steering tube

Rear

Removing the rear wheel

- Remove the muffler.
- Remove the cotter pin and remove the cap.



- Unscrew the nut fixing the wheel axle and collect the washer.



Refitting the rear wheel

- To refit, follow the removal steps but in reverse order; be careful to tighten to the prescribed torque.

Locking torques (N*m)
Locking torque 137 ÷ 152 Nm

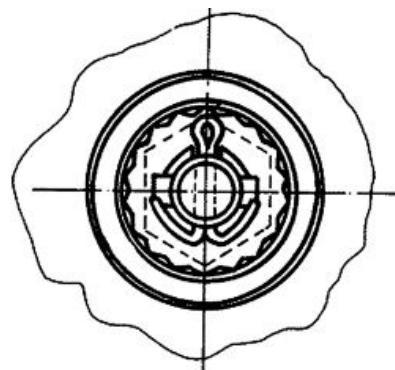

Swing-arm



Removal

- Support the scooter adequately.
- Remove the central tunnel inspection door.
- To remove the upper clamp from the chassis, proceed as follows:

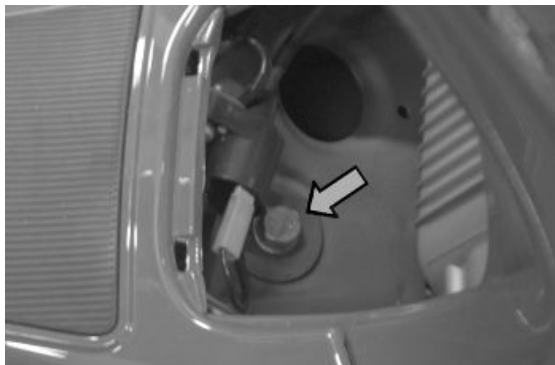

- Unscrew the pin and collect the washer.



- Remove the cap from the lower part.



- Collect the lower fixing nut and collect the washer.

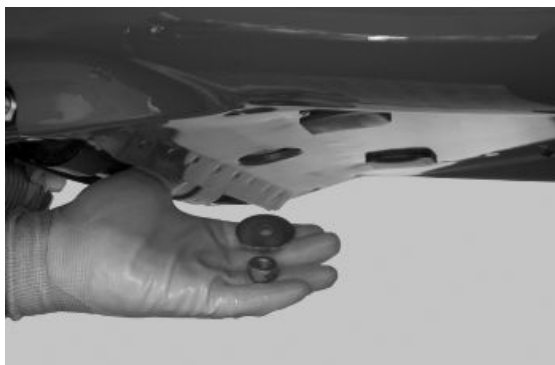

- Working on both sides, remove the cover caps.

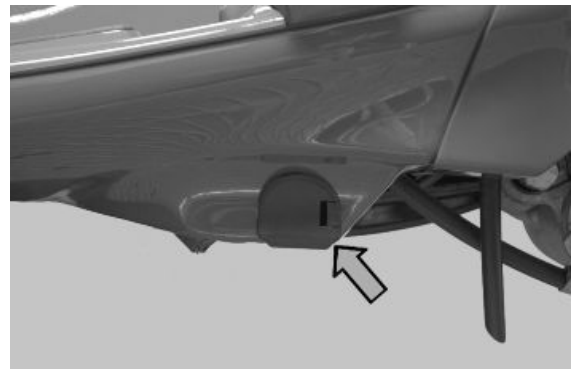

- Working on the right side, unscrew the side fixing nut to the chassis and collect the washer.

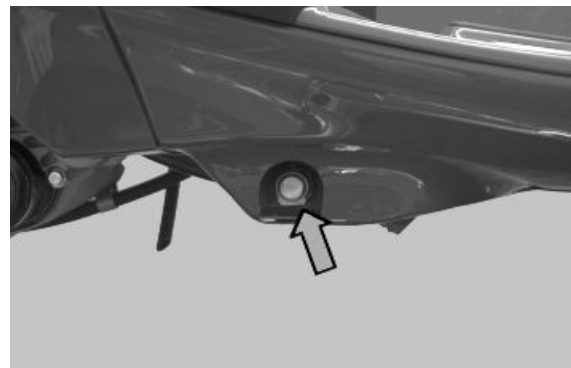

- Working on the left side, remove the pin.



- Remove the spoiler terminal from both sides.
- Working on the right side, unscrew the fixing nut.

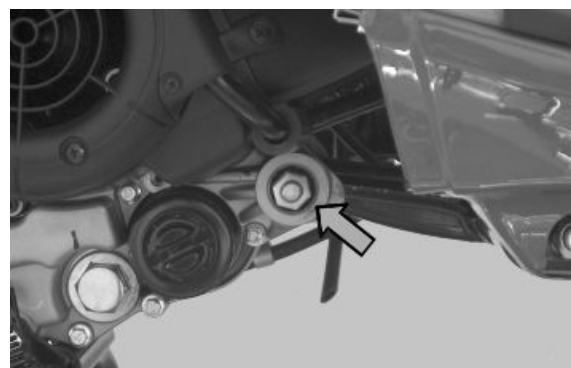

- Working on the left side, release the pin from the spring shown.

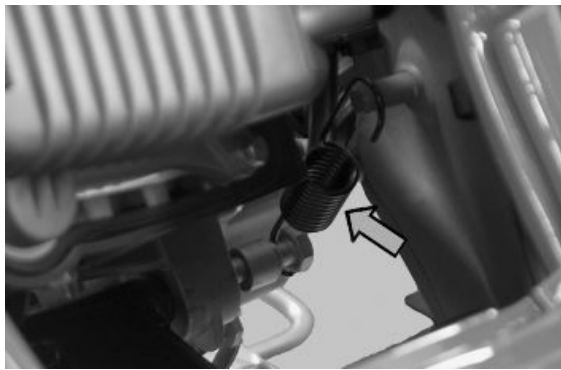

- Remove the fixing pin to the engine and collect the spacer.
- Now the swinging arm is free.



- Remove the swinging arm from the vehicle; first release it from the engine side and then from the chassis side.



Overhaul

- Check that the silent-blocks are in good conditions.
- Otherwise, replace the swinging arm.

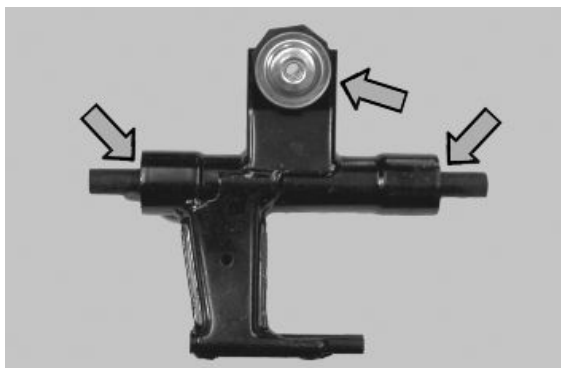

Refitting

- To fit, follow the removal steps but in reverse order; be careful to tighten to the prescribed torques.

Locking torques (N*m)

Part A 33 ÷ 41 Part B 44 ÷ 52 Part C 33 ÷ 41

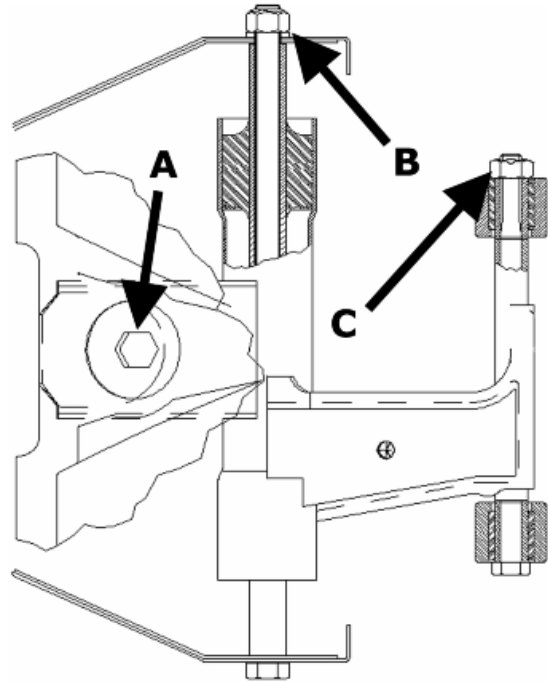

Shock absorbers

Removal

- Adequately support the rear part of the scooter.
- Remove the battery cover.
- Undo the indicated upper fixing screw to the frame.



- Unscrew the lower fixing pin to the transmission crankcase.

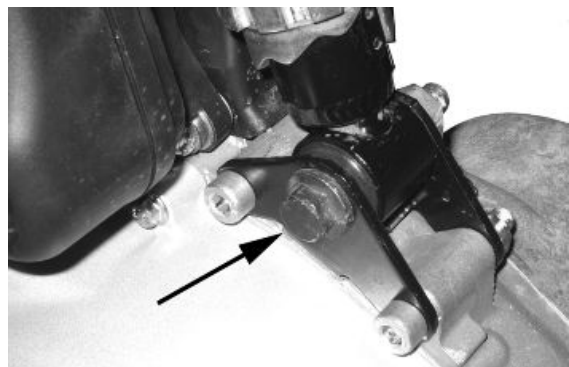

Refitting

- To fit, follow the removal steps but in reverse order; be careful to tighten to the prescribed torques.

Locking torques (N*m)

Shock absorber/engine pin torque 33 to 41 N-m Shock absorber/frame nut torque 20 to 25 Nm

Centre-stand

REMOVAL

- Use a jack to support the vehicle properly.
- Remove the two return springs from the centre stand.
- Undo the nut shown in the figure.
- Remove the bolt from the right side.
- Remove the centre stand.

FITTING

- On refitting tighten the nut to the specified torque.



Locking torques (N*m)

Centre stand screw 32 ÷ 40

Side stand

REMOVAL

- Uncouple the centre stand return spring;
- Remove the screw shown in the photograph

FITTING

To refit, carry out the removal operations in reverse order and comply with the specified torque.

Locking torques (N*m)

Side stand fixing bolt 35 ÷ 40

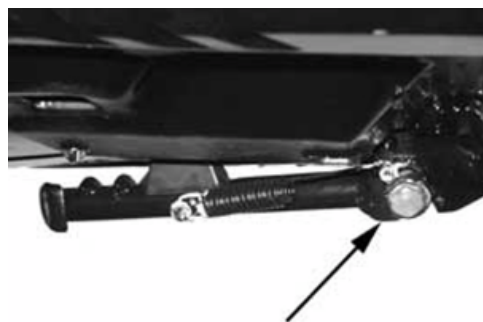

INDEX OF TOPICS

BRAKING SYSTEM

BRAK SYS

Front brake calliper

Removal

- Remove the front wheel.
- Undo the two fixing screws to the shock absorber - calliper support.

N.B.

SHOULD IT BE NECESSARY TO REPLACE THE CALLIPER, FIRST LOOSEN THE FITTING CONNECTING THE PIPE TO THE BRAKE CALLIPER.



Refitting

To fit, follow the removal steps but in reverse order; be careful to tighten to the prescribed torques.

N.B.

ONCE REFITTING IS FINISHED, BLEED THE SYSTEM.

Locking torques (N*m)

Screw tightening calliper to the support 20 ÷ 25 Brake pipe connection 20 to 25 N*m

Front brake disc

Removal

- Remove the front wheel
- Remove the front brake calliper
- Remove the hub and the disc operating on the wheel axle nut
- Adequately support the hub with the disc and operating on the five screws shown in the photograph, remove the brake disc



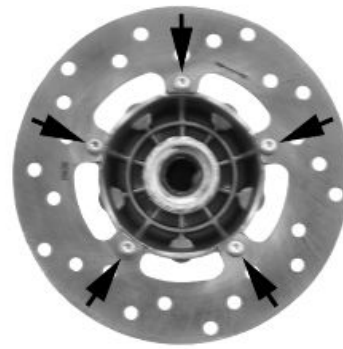

Refitting

- Carry out the operations in the reverse order from the removal being careful to respect the direction of disc rotation shown by the arrow printed on it
- Tighten the 5 screws to the specified torque

Recommended products

Loctite 243 Medium strength threadlock

Loctite 243 medium-strength threadlock

Locking torques (N*m)

Brake disc screws 8 ÷ 10

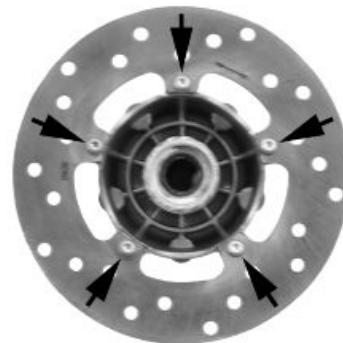

Disc Inspection

- Remove the front wheel
- Use a micrometer to check the disc thickness as shown in the photograph
- Repeat the measurement in at least 6 points on the disk
- Remove the front brake calliper
- In order to secure the appropriate tool adequately use a metal plate with M8 threaded hole and fix it to one of the two front brake calliper attachment points
- Place the dial gauge on the disk outer edge
- Make the wheel hub turn and check the disk deviation



Specific tooling

020335Y Magnetic support for dial gauge

Characteristic**Minimum thickness allowed after use:**

4 mm

Disc thickness at wear limit (front)

3.5 mm

Max. deviation allowed:

0.1 mm



- If a value other than that prescribed is detected, replace the disc and check again.
- If the problem persists, check and replace the wheel hub if required.

Front brake pads

Removal

Proceed as follows:

- Remove the front calliper.
- Remove the cotter pin and slide off the pin that locks the two pads.
- Remove the pads, being careful with the pad spring clamp.
- Check the thickness of the friction material of the pads.
- Replace the pads if the thickness is below the minimum value.
- The replacement must be made with greater residual thickness if the pad has not worn evenly. A 0.5 mm thickness difference in the residual friction material is permitted.

**Characteristic****Minimum value**

1.5 mm

See also

[Front](#)
brake calliper

Refitting

- Insert the brake pads
- Insert the fixing pin being careful to position the clip with the ends towards the bleed screw as in the photo.



- Insert the lock on the bolt and then the protection cover



Fill

Front

- Remove the rubber cap from the bleed screw.
- Insert a rubber pipe in the bleed screw to permit the brake fluid to be recovered.
- With the right-hand brake lever, load the system and bring it up to the required pressure.
- Keeping the right-hand brake lever pulled, loosen the bleed screw to purge the air. Then tighten the bleed screw
- Release the brake lever
- Repeat the operation until only brake fluid comes out of the rubber pipe.
- Remove the fluid recovery pipe and refit the rubber cap over the bleed screw.
- Top up the brake fluid to the right level in the reservoir.



If necessary, bleeding can be done using a special vacuum pump

N.B.

DURING PURGING FREQUENTLY CHECK THE LEVEL TO PREVENT AIR GETTING INTO THE SYSTEM THROUGH THE PUMP.

N.B.

DURING THE BLEEDING OPERATIONS, MAKE SURE THE BRAKE FLUID DOES NOT COME INTO CONTACT WITH THE BODYWORK SO AS NOT TO DAMAGE IT. FURTHERMORE, DURING THE BLEEDING OPERATIONS REGARDING THE BRAKE CALLIPERS, MAKE SURE THE BRAKE FLUID DOES NOT COME INTO CONTACT WITH THE DISC BRAKES AND WITH THE BRAKE PADS. FAILURE TO COMPLY WITH THIS NORM WILL ENDANGER THE PROPER WORKING AND EFFICIENCY OF THE BRAKING SYSTEM

Specific tooling

020329Y MityVac vacuum-operated pump

Locking torques (N*m)

System bleed calliper fitting: 20 ÷ 25 Nm

Brake fluid level check

- Rest the vehicle on its centre stand on flat ground.
- The brake fluid reservoir has a sight glass «A» made of transparent material; the quantity of liquid contained in the sight glass indicates the level of fluid in the reservoir.
- When the sight glass «A» is full, the level inside the reservoir is above the MIN level; when it is partially full, the level has dropped to the MIN level; when it is fully empty, the level of fluid in the reservoir is below the MIN level.

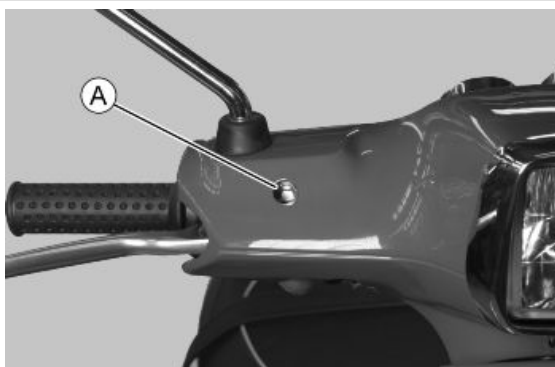

N.B.

THE LEVEL TENDS TO DROP AS THE BRAKE PADS GET WORN, A MINIMUM LEVEL SHOULD NOT BE REACHED. IF THE LEVEL IS TOO LOW, CHECK AND FIX THE SYSTEM SEALS, IF REQUIRED. TOP UP THE PUMP TANK, IF REQUIRED, CONSIDERING THAT THE "MAX." LEVEL MUST ONLY BE OBTAINED WITH NEW PADS.

- Under standard climatic conditions, replace fluid as indicated in the scheduled maintenance table.

Front brake pump

Removal

- Remove the front and rear handlebar covers
- Remove the two screws fixing the brake pump to the handlebar indicated in the photograph
- Remove the oil pipe joint from the pump
- Remove the connector to the stop light switch



Overhaul

Proceed as follows:

- 1) Remove the brake lever by loosening the retaining screw; open the cover (2) and take out the diaphragm (3);
- 2) remove the cap (4) and take out the internal parts in order;
- 3) Check that:
 - The body of the pump shows no signs of internal damage or corrosion;
 - The plunger shows no sign of damage or abnormal wear;
 - The plunger return spring is in good condition.

CAUTION

ALL THE SEALS AND GASKETS MUST BE REPLACED EVERY TIME THE PUMP IS SERVICED.

1. Reservoir cap screw
2. Reservoir cap.
3. Diaphragm.
4. Bellows.
5. Sealing ring
6. Piston.
7. Gasket.
8. Spring.
9. Reservoir

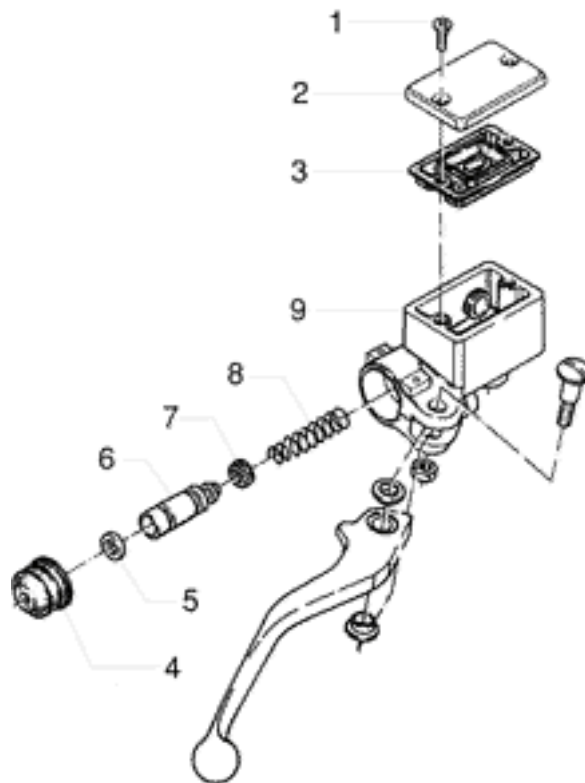

Refitting

To refit, carry out the removal operations but in reverse order, observing the specified torques.

N.B.

USE NEW COPPER GASKETS ON THE JOINTS.

CAUTION

ONCE REFITTING IS FINISHED, BLEED THE SYSTEM.

Locking torques (N*m)

Oil pipe joint to the pump: 20 - 25 Brake pump fixing screws to the handle bar: $7 \div 10$ Nm Pipe / brake calliper coupling 20 \div 25

Rear drum brake

Once the muffler and the wheel have been removed, follow these steps:

- Remove the shoe spring using the specific pliers.
- Remove the shoes with the help of a lever.
- Refit the new shoes with a few taps with the mallet.
- Attach the spring using the specific spanner.

CAUTION

REPLACE THE SHOES BEFORE THE FRICTION MATERIAL IS FULLY WORN

Specific tooling

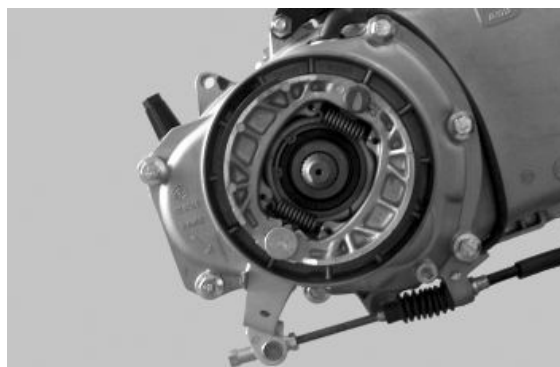

020325Y Brake-shoe spring calliper

INDEX OF TOPICS

CHASSIS

CHAS

Seat

- Lift the saddle and remove the helmet compartment «A».

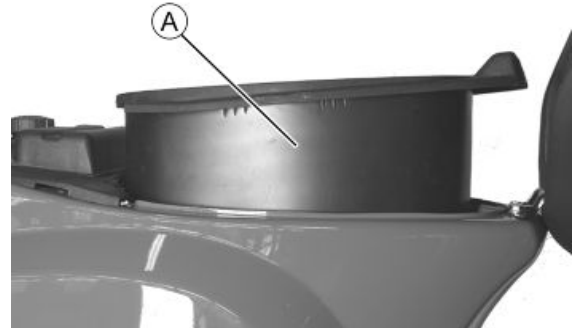

- Undo the two screws indicated.

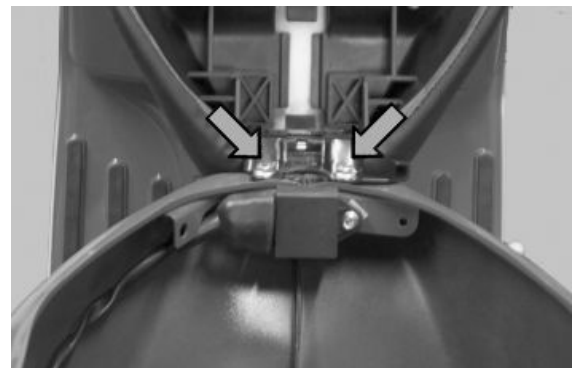

Rear handlebar cover

- Remove the front handlebar cover.
- Undo the three screws indicated in figure fixing it to the handlebar, the odometer transmission and the electrical connectors.

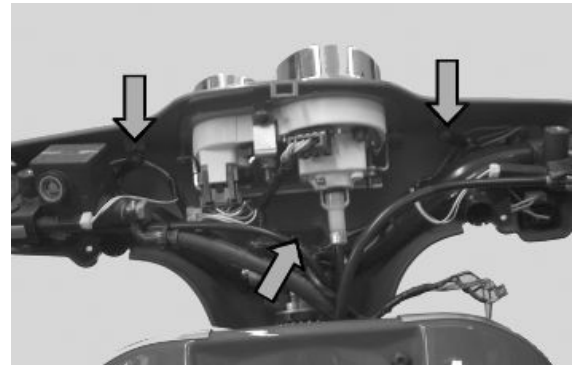

Instrument panel

- Remove the rear handlebar cover.
- Undo the three screws indicated fixing the rear handlebar cover.

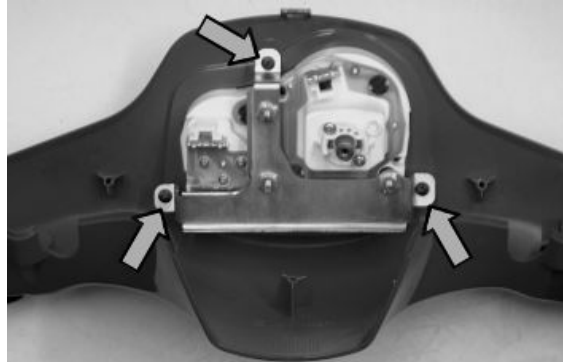

Front handlebar cover

Proceed as follows:

- Remove the rear-view mirrors.
- Undo the two screws «A».

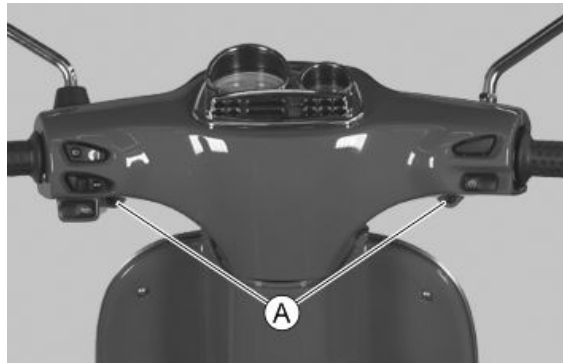

- Undo the screw «B» and remove the front handlebar cover.



- Disconnect the electrical terminals and remove the turn indicator bulb.

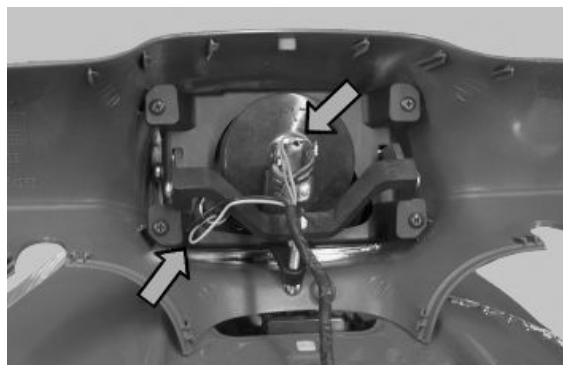

Headlight assy.

- Remove the front handlebar cover.
- Undo the four screws indicated fixing the front handlebar cover.

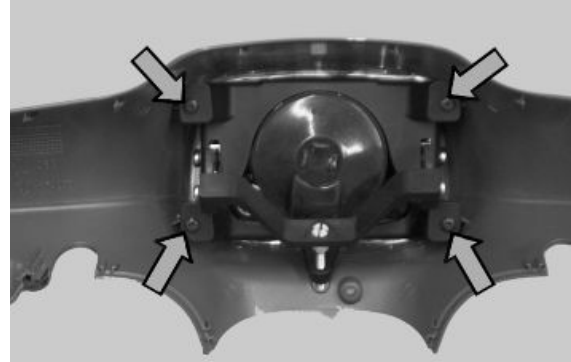

Knee-guard

- Undo the five screws indicated.

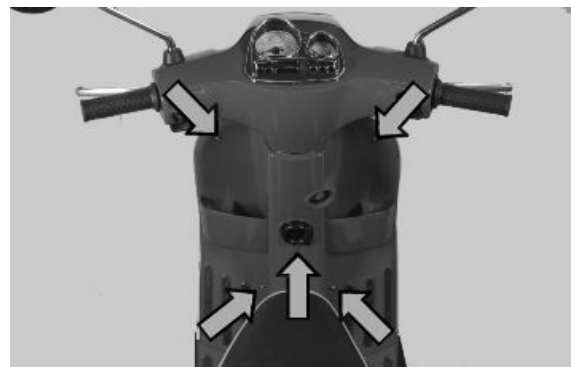

- Remove the rubber strip from both sides and undo the indicated screw.

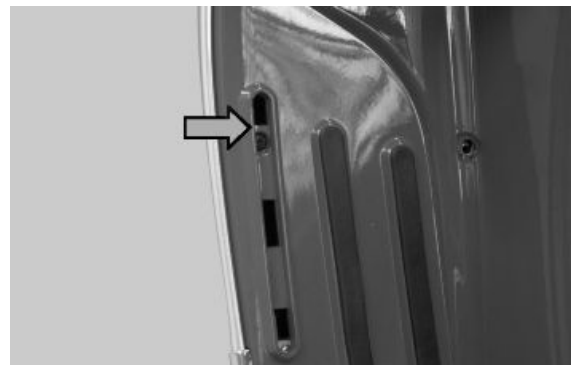

- Remove the shield back plate bringing it to the rear part of the scooter.

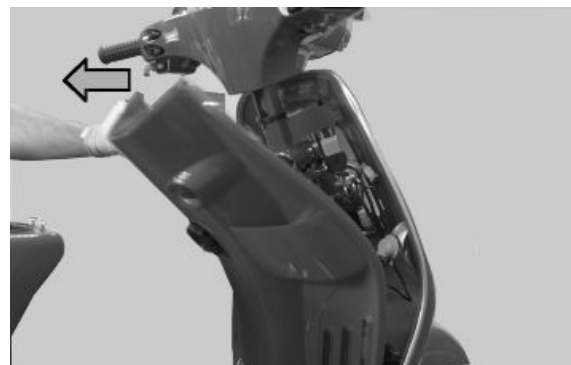

Taillight assy.

- Undo the two fixing screws and remove the rear light unit.



- Undo the screw indicated and disconnect the connector.

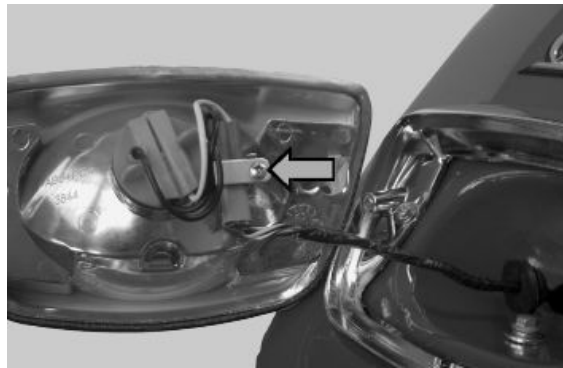

Footrest

- Remove the shield back plate.
 - Remove the side fairings.
 - Remove the central tunnel inspection door.
- From both sides, unscrew:
- The fixing screw at the back.

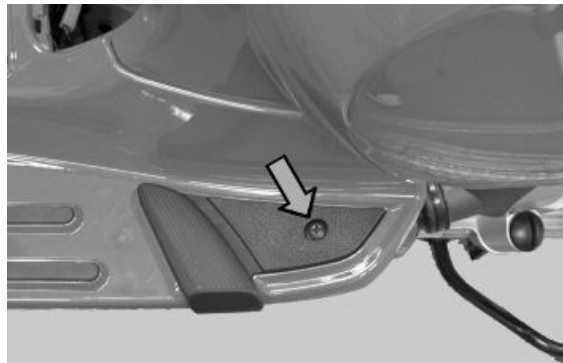

- The fixing screw on the central part.

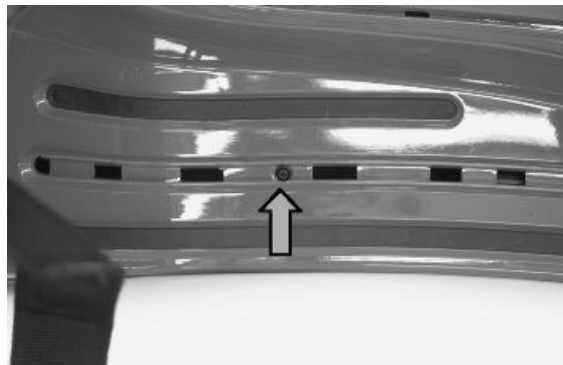

- The fixing screw at the front.

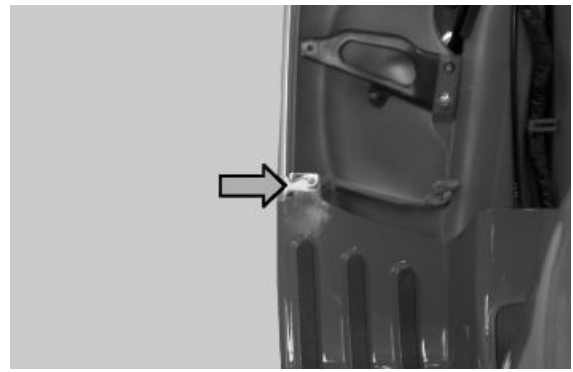

- Remove the footrest.

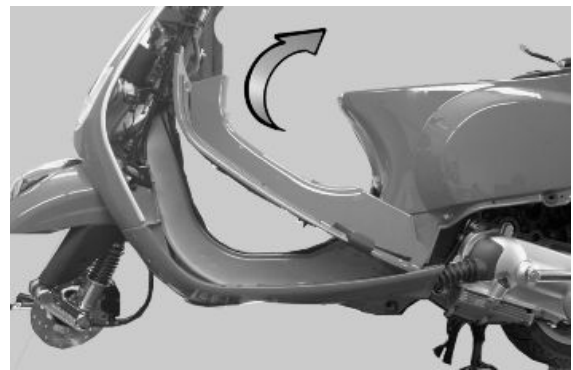

Side fairings

- Undo the screw «A» and the smaller screw «B».

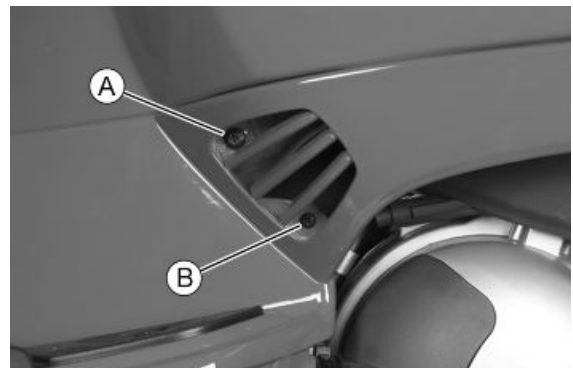

- Detach the seats on the fairing.



License plate holder

- Remove the side fairings.
- Working on both sides, undo the two screws indicated.

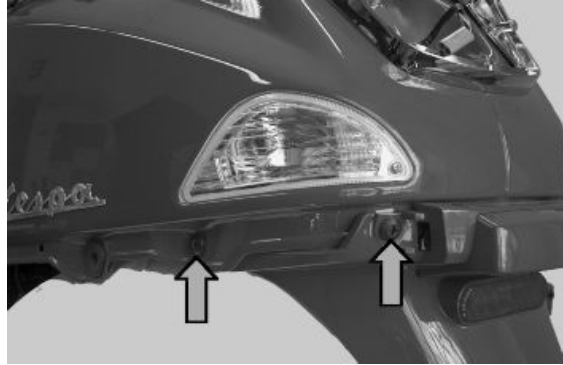

-
- Remove the license plate light.

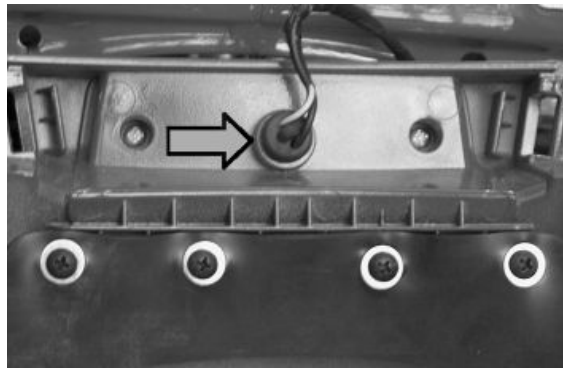

Air filter

- Remove the helmet compartment.
- Remove the side fairings.
- Undo the two indicated clamps to the crankcase.



-
- Undo the two clamps indicated.

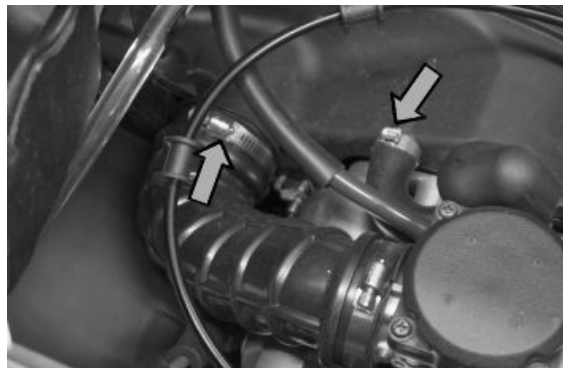

Fuel tank

- Adequately support the rear part of the scooter.
- Remove the wheel and the rear mudguard.
- Remove the battery compartment.
- Disconnect the fuel outlet pipe.
- Undo the two fixing screws to the chassis and collect the fuel pipe supporting plate.

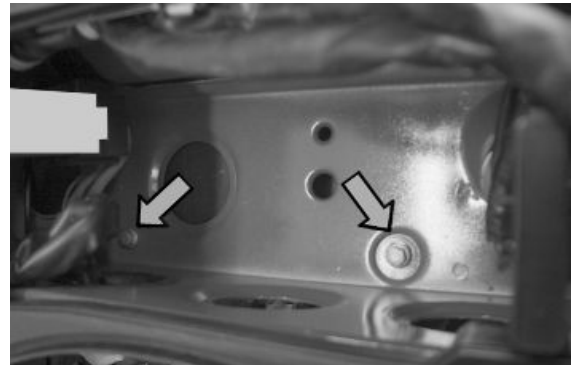

- Remove the turn indicators.
- Remove the rear light unit and undo the indicated screw.



- Unscrew the closing cap.
- Lower the fuel tank and disconnect the bleed pipes and the level indicator connector.

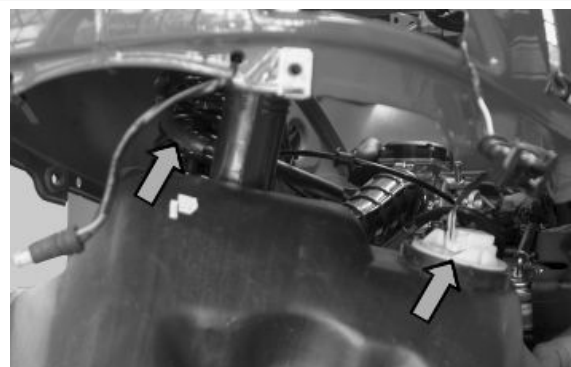

-
- Remove the tank.



Front mudguard

- First remove the steering tube and uncouple the front brake pipes from the calliper in order to remove the front mudguard
- Remove the three mudguard-steering tube clamps indicated in the figure

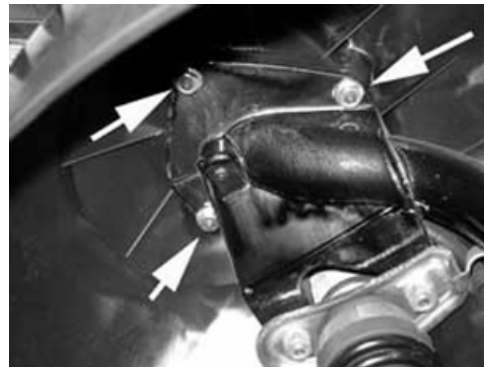

Front central cover

- Remove the "Piaggio" clip-on badge.

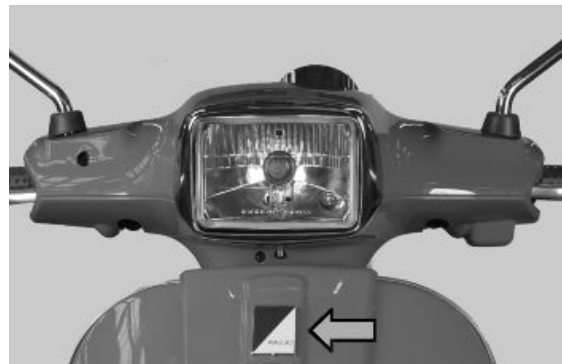

- Undo the two screws indicated.

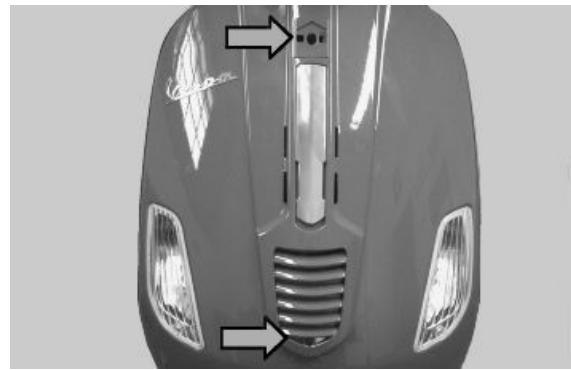

- Remove the front central cover, sliding it upwards.

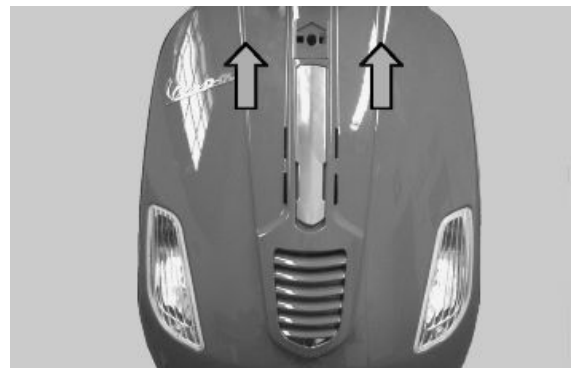

INDEX OF TOPICS

PRE-DELIVERY

PRE DE

Aesthetic inspection

Appearance check:

- Paintwork
- Fitting of plastics
- Scratches
- Dirt

Tightening torques inspection

Lock check

- Safety locks
- clamping screws

Safety locks

Rear shock absorber upper fixing

Rear shock absorber lower fixing

Front wheel axle nut

Wheel hub nut

Frame - swinging arm bolt *

Swinging arm bolt - Engine

Engine arm pin - Frame arm

Handlebar lock nut

Steering lower ring nut

Upper steering ring nut

Electrical system

Electrical system:

- Main switch
- Headlamps: high-beam lights, low-beam lights, tail and parking lights and their warning lights
- Adjusting the headlights according to the regulations currently in force
- Rear light, parking light, stop light
- Front and rear stop light switches
- Turn indicators and their warning lights
- Instrument panel lights
- Instrument panel: fuel gauge
- Instrument panel warning lights
- Horn
- Starter

CAUTION

TO ENSURE MAXIMUM PERFORMANCE, THE BATTERY MUST BE CHARGED BEFORE USE. INADEQUATE CHARGING OF THE BATTERY WITH A LOW LEVEL OF ELECTROLYTE BEFORE IT IS FIRST USED SHORTENS BATTERY LIFE.

WARNING

BEFORE RECHARGING THE BATTERY, REMOVE THE CAPS OF EACH CELL. KEEP THE BATTERY AWAY FROM NAKED FLAMES OR SPARKS WHILE IT IS CHARGED. REMOVE THE BATTERY FROM THE SCOOTER, DISCONNECTING THE NEGATIVE TERMINAL FIRST.

CAUTION

WHEN INSTALLING THE BATTERY, ATTACH THE POSITIVE LEAD FIRST AND THEN THE NEGATIVE LEAD.

WARNING

BATTERY ELECTROLYTE IS TOXIC AND IT MAY CAUSE SERIOUS BURNS. IT CONTAINS SULPHURIC ACID. AVOID CONTACT WITH EYES, SKIN AND CLOTHING.

IN CASE OF CONTACT WITH EYES OR SKIN, RINSE WITH ABUNDANT WATER FOR ABOUT 15 MINUTES AND SEEK MEDICAL ATTENTION AT ONCE.

IF IT IS SWALLOWED, IMMEDIATELY DRINK LARGE QUANTITIES OF WATER OR VEGETABLE OIL. SEEK IMMEDIATE MEDICAL ATTENTION.

BATTERIES PRODUCE EXPLOSIVE GAS; KEEP THEM AWAY FROM NAKED FLAMES, SPARKS AND CIGARETTES. IF THE BATTERY IS CHARGED IN A CLOSED PLACE, TAKE CARE TO ENSURE ADEQUATE VENTILATION. ALWAYS PROTECT YOUR EYES WHEN WORKING CLOSE TO BATTERIES.

KEEP OUT OF THE REACH OF CHILDREN

CAUTION

NEVER USE FUSES WITH A CAPACITY HIGHER THAN THE RECOMMENDED CAPACITY. USING A FUSE OF UNSUITABLE RATING MAY SERIOUSLY DAMAGE THE VEHICLE OR EVEN CAUSE A FIRE.

Levels check

Level check:

- Hydraulic brake system fluid level.
 - Rear hub oil level
 - Engine oil level
-

Road test

Test ride

- Cold start
 - Instrument operations
 - Response to the throttle control
 - Stability on acceleration and braking
 - Rear and front brake efficiency
 - Rear and front suspension efficiency
 - Abnormal noise
-

Static test

Static control after the test ride:

- Starting when warm
- Starter operation
- Minimum hold (turning the handlebar)
- Uniform turning of the steering
- Possible leaks

CAUTION

CHECK AND ADJUST TYRE PRESSURE WITH TYRES AT AMBIENT TEMPERATURE.

CAUTION

NEVER EXCEED THE RECOMMENDED INFLATION PRESSURES OR TYRES MAY BURST.

Functional inspection

Functional check up:

Braking system (hydraulic)

- Lever travel

Braking system (mechanical)

- Lever travel

Clutch

- Proper functioning check

Engine

- Throttle travel check

Others

- Check documentation
 - Check the frame and engine numbers
 - Tool kit
 - License plate fitting
 - Check locks
 - Check tyre pressures
 - Installation of mirrors and any accessories
-

INDEX OF TOPICS

TIME

TIME

Engine

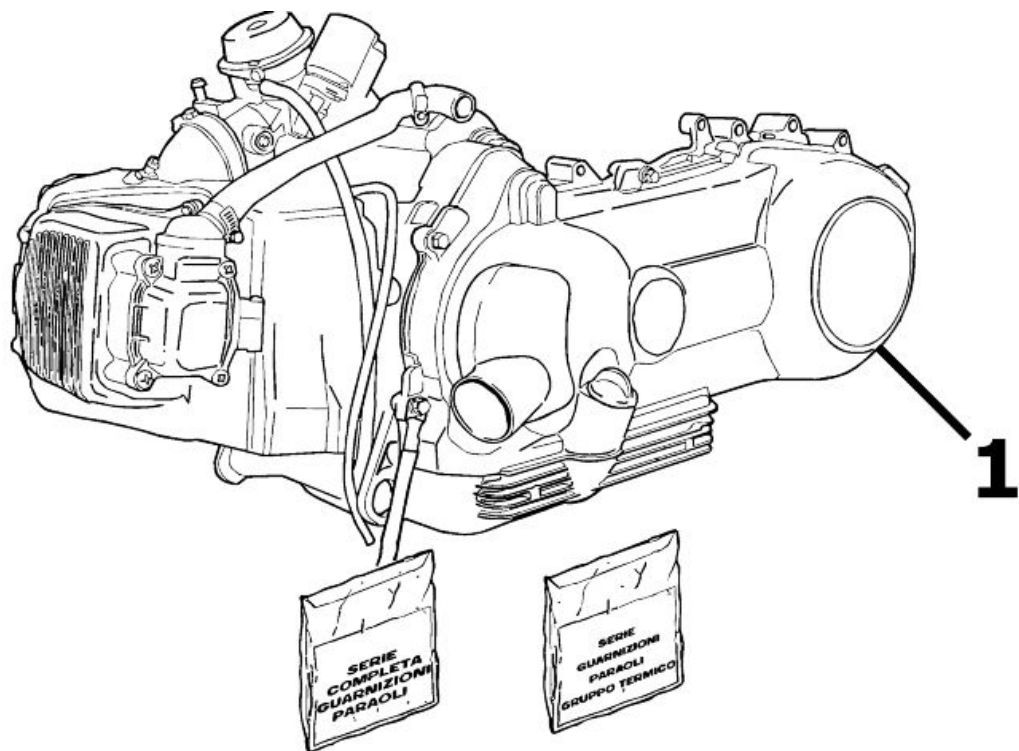

ENGINE

	Code	Action	Duration
1	001001	engine from frame - removal and re-fitting	

Crankcase

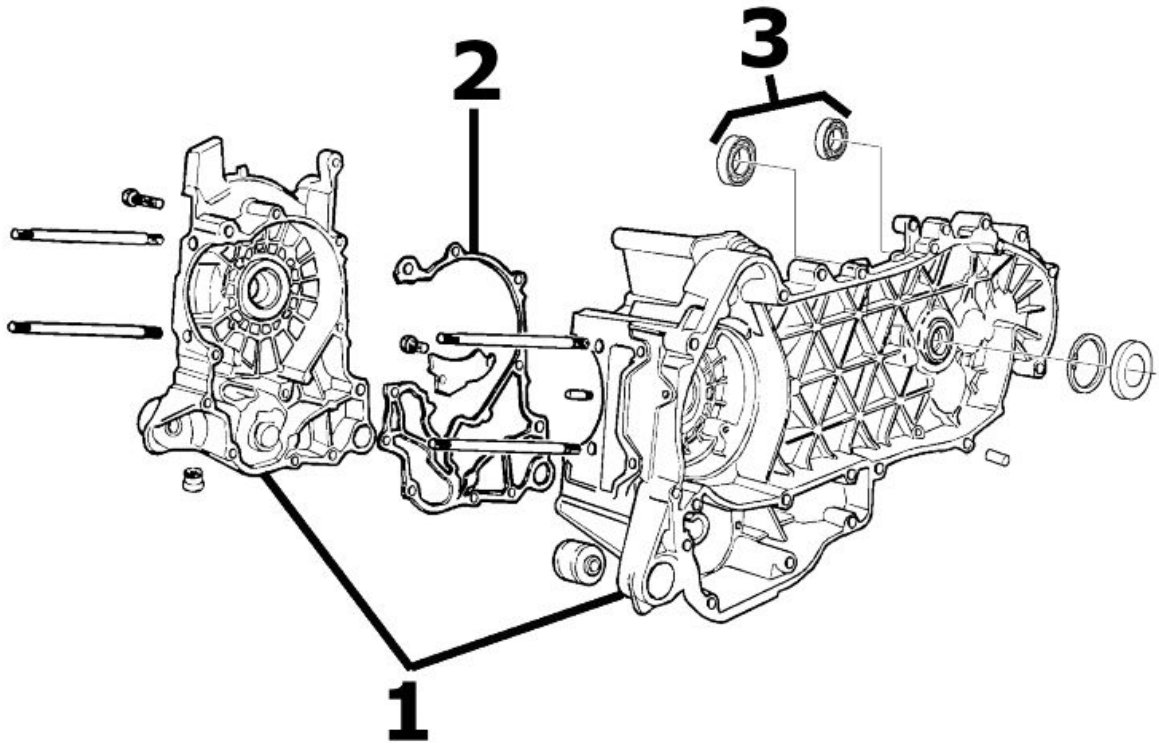
**CRANKCASE**

	Code	Action	Duration
1	001133	Engine crankcase - Replacement	
2	001153	Half crankcase gasket - Replacement	
3	002031	Rear wheel hub bearings - Replacement	

Crankshaft

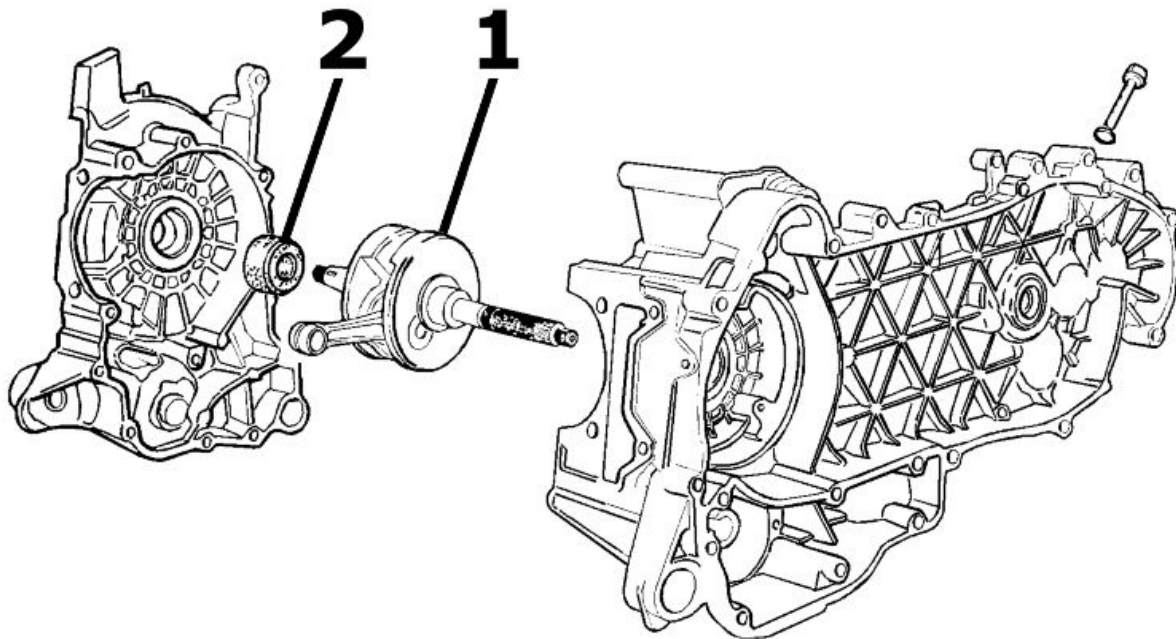

CRANKSHAFT

	Code	Action	Duration
1	001117	Crankshaft - Replacement	
2	001099	Oil seal, flywheel side - Replacement	

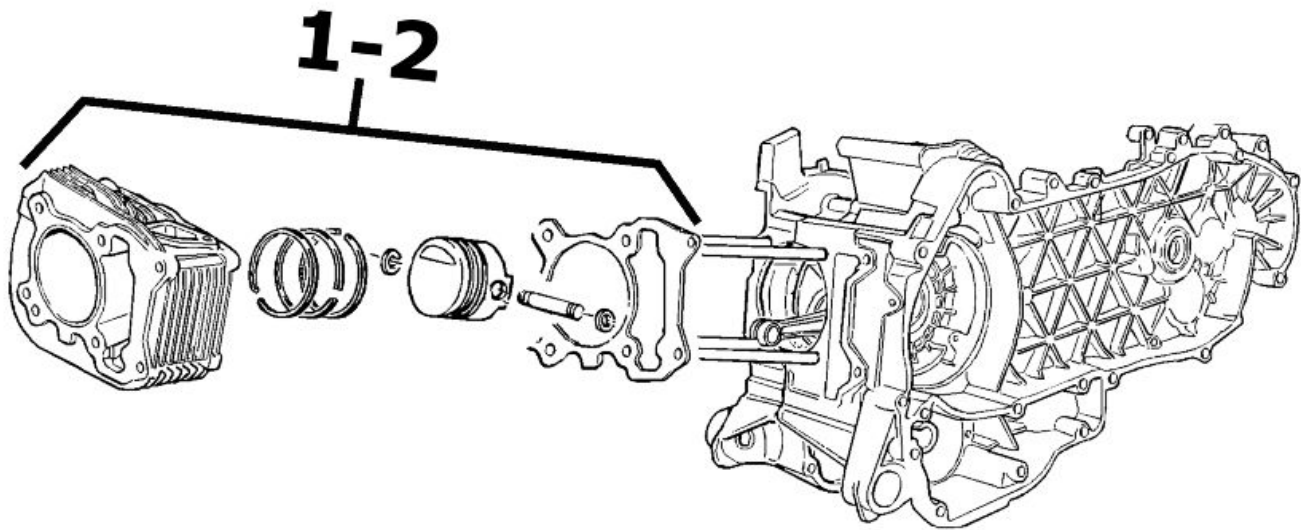
Cylinder assy.**CYLINDER GROUP**

	Code	Action	Duration
1	001002	Cylinder-Piston - Replacement	
2	001107	Cylinder / piston - Inspection / cleaning	

Cylinder head assy.

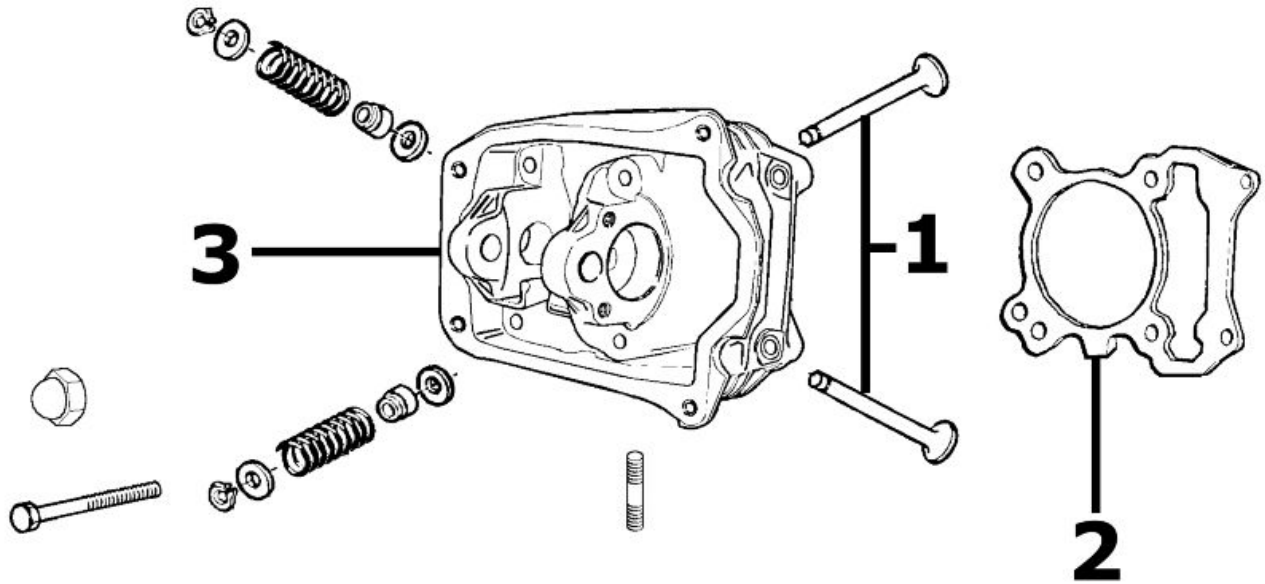

HEAD UNIT

	Code	Action	Duration
1	001045	Valves - Replacement	
2	001056	Head gasket - change	
3	001126	Head - Replacement	

Rocker arms support assy.

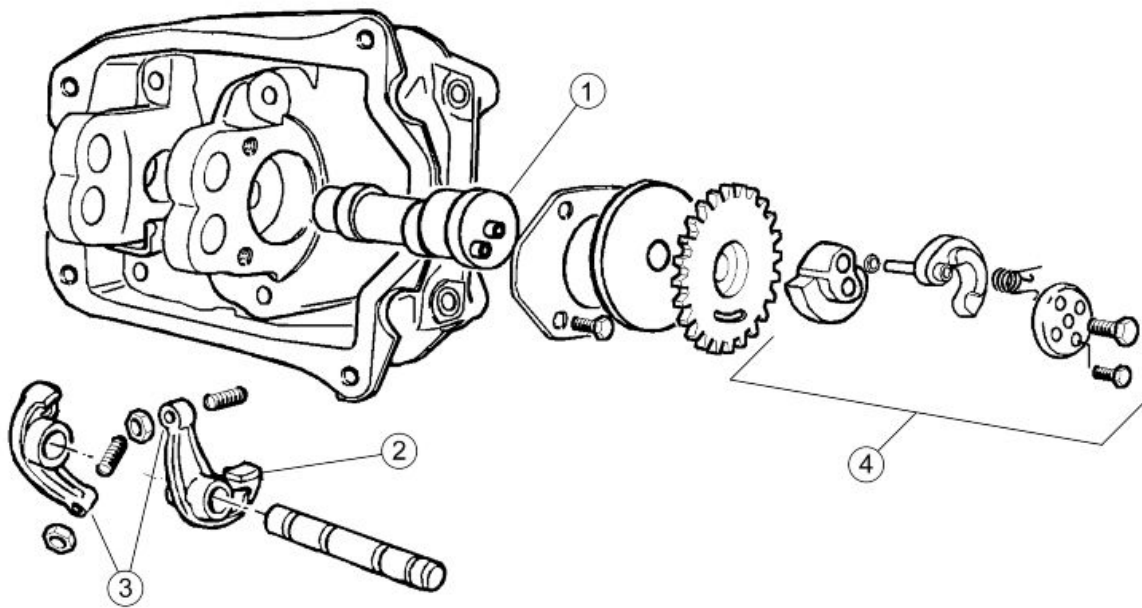

ROCKING LEVER SUPPORT UNIT

	Code	Action	Duration
1	001044	Camshaft - Replacement	
2	001148	Rocking lever valve - Replacement	
3	001049	Valves - Adjustments	
4	001169	Decompressor - Replacement	

Cylinder head cover

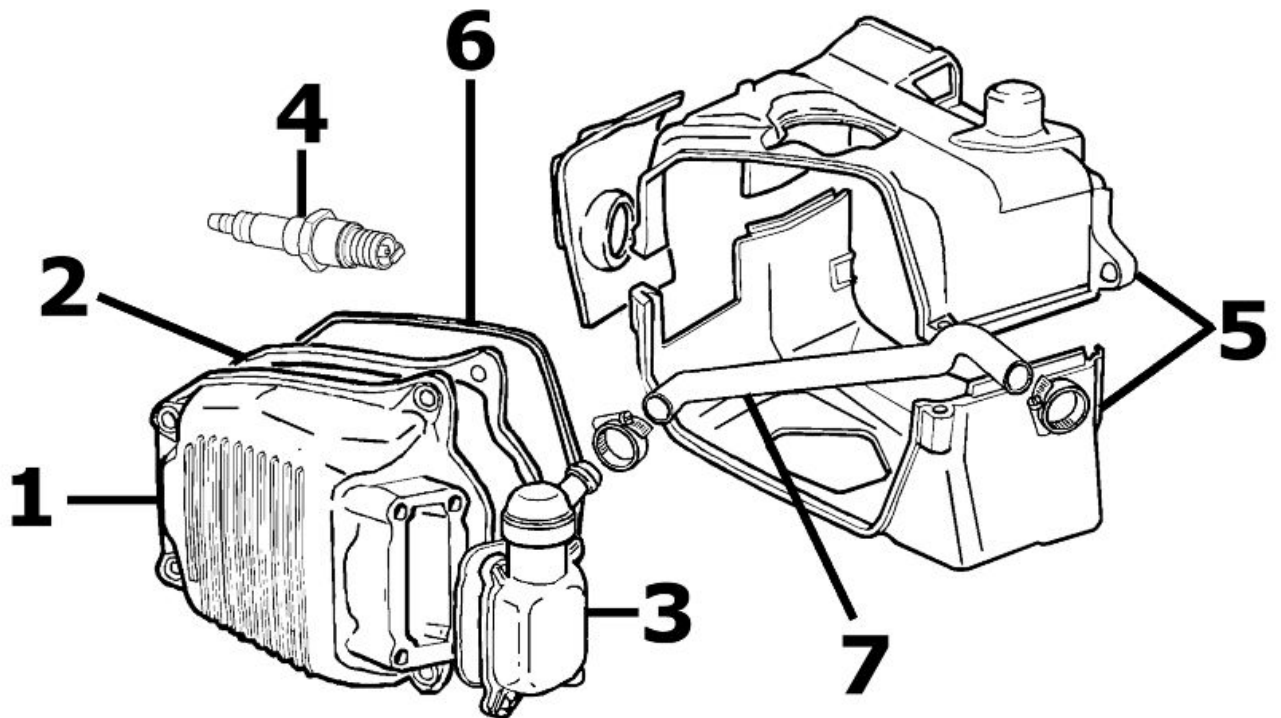

HEAD COVER

	Code	Action	Duration
1	001089	Head cover - Replacement	
2	001088	Head cover gasket - Replacement	
3	001159	Oil vapour recovery tank - Service	
4	001093	Spark plug - Replacement	
5	001097	Cooling hood - Replacement	
6	001091	Head cover sealing ring	
7	001074	Oil vapour recovery pipe - Replacement	

Chain tensioner

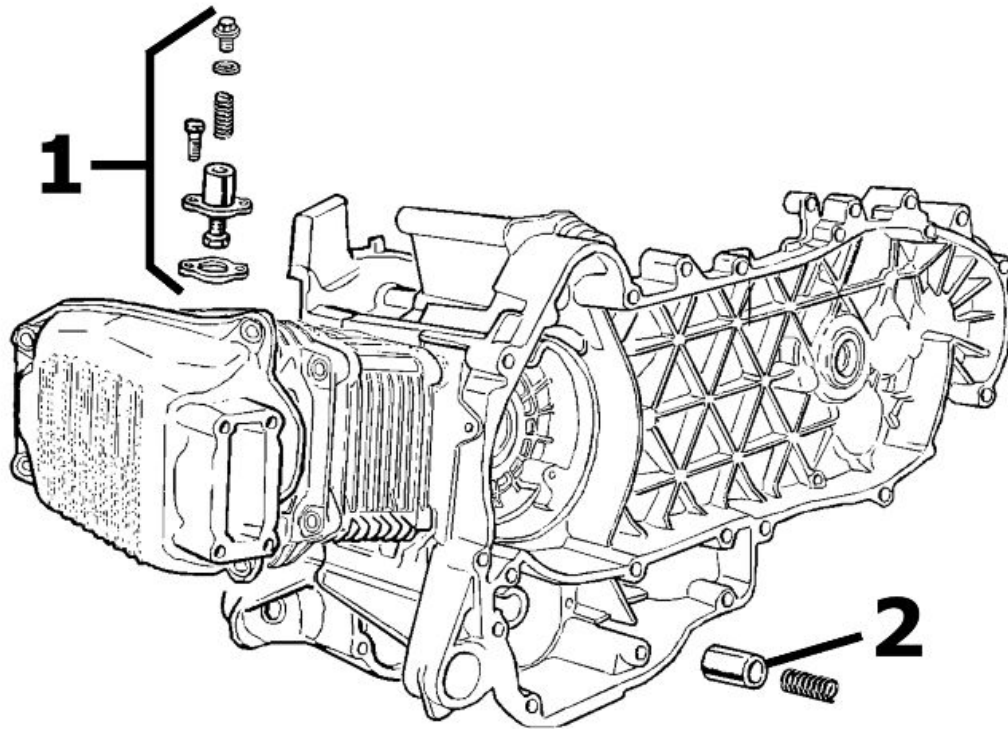
**CHAIN TIGHTENER**

	Code	Action	Duration
1	001129	Chain tensioner - Service and Replacement	
2	001124	By pass lubrication - Replacement	

Oil filter

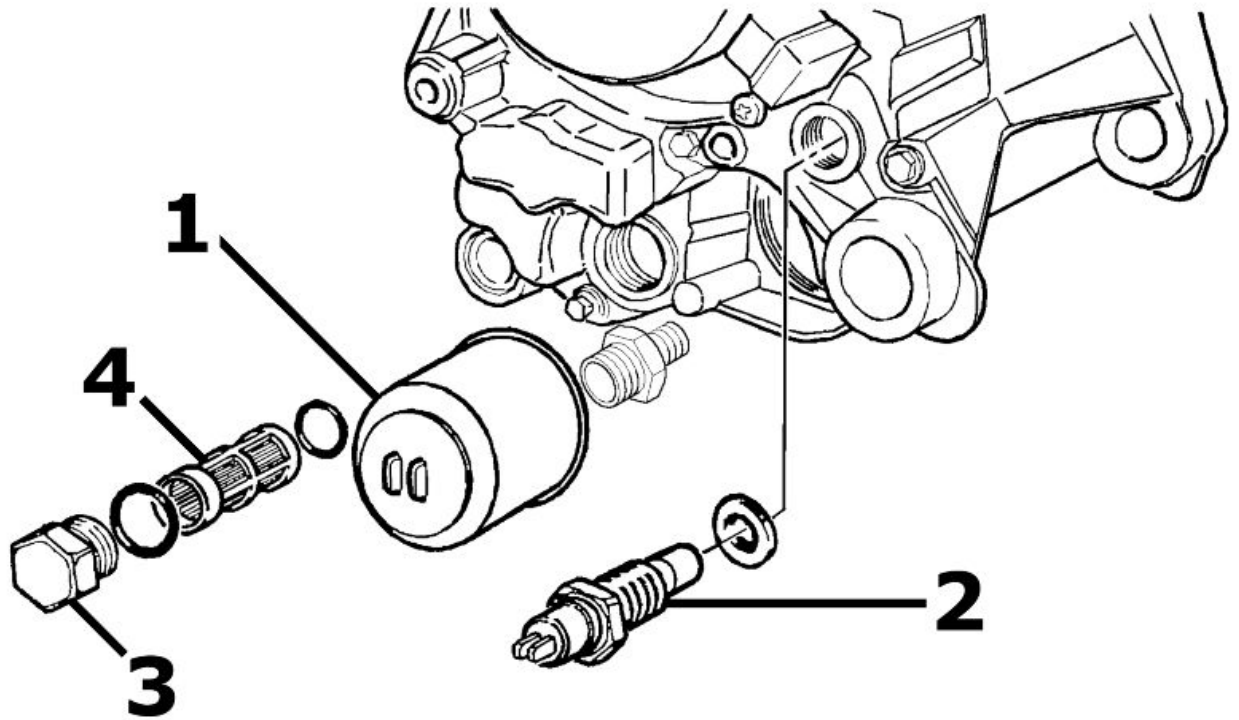

OIL FILTER

	Code	Action	Duration
1	001123	Oil filter - Replacement	
2	001160	Oil pressure sensor - Replacement	
3	003064	Engine oil - Change	
4	001102	Net oil filter - Replacement / Cleaning	

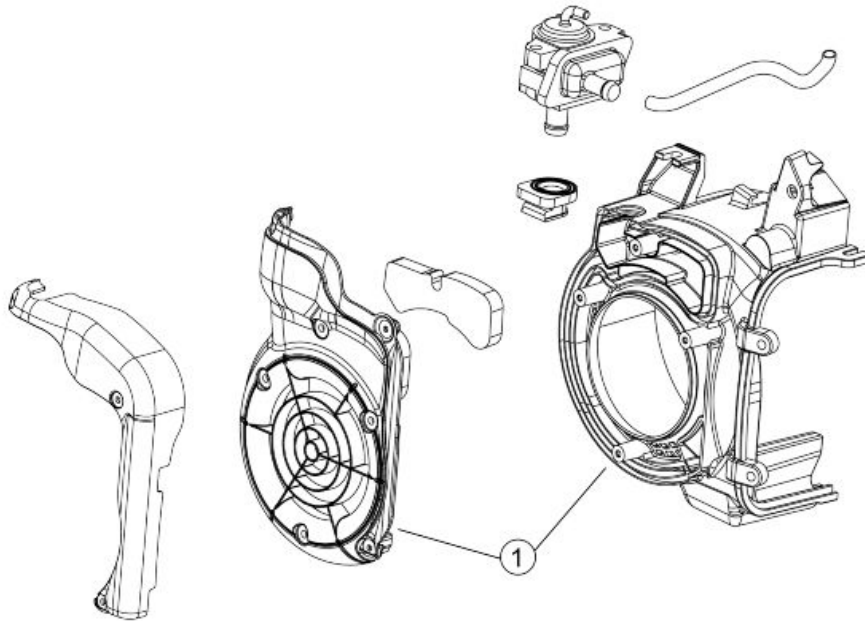
Flywheel cover**FLYWHEEL COVER**

	Code	Action	Duration
1	001087	Flywheel cover - Replacement	

Driven pulley

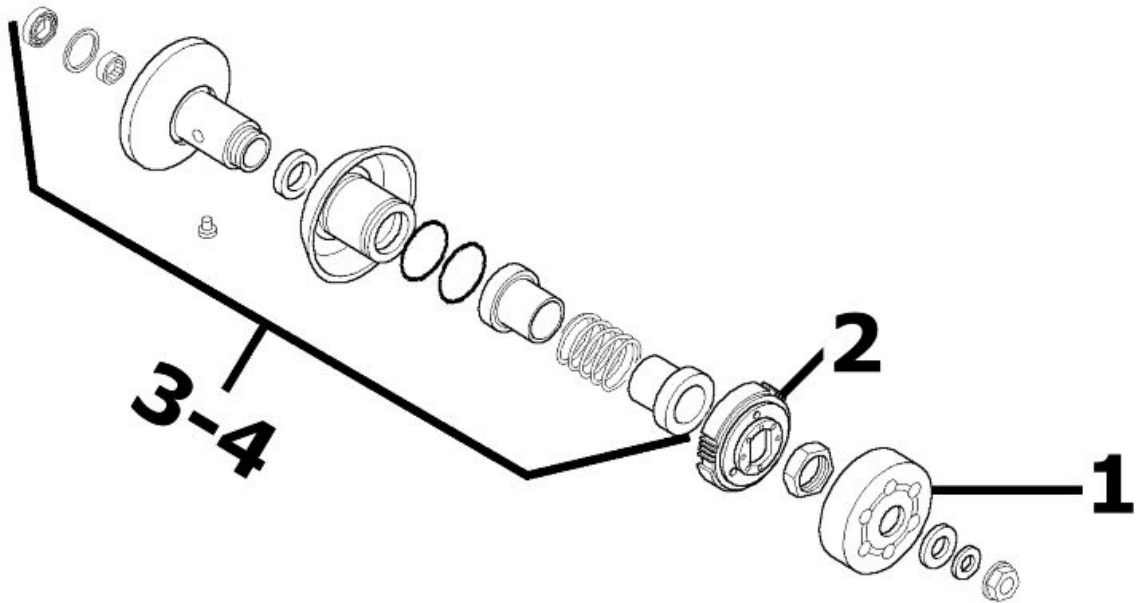

DRIVEN PULLEY

	Code	Action	Duration
1	001155	Clutch bell housing - Replacement	
2	001022	Clutch - Replacement	
3	001012	Driven pulley - Overhaul	
4	001110	Driven pulley - Replacement	

Oil pump

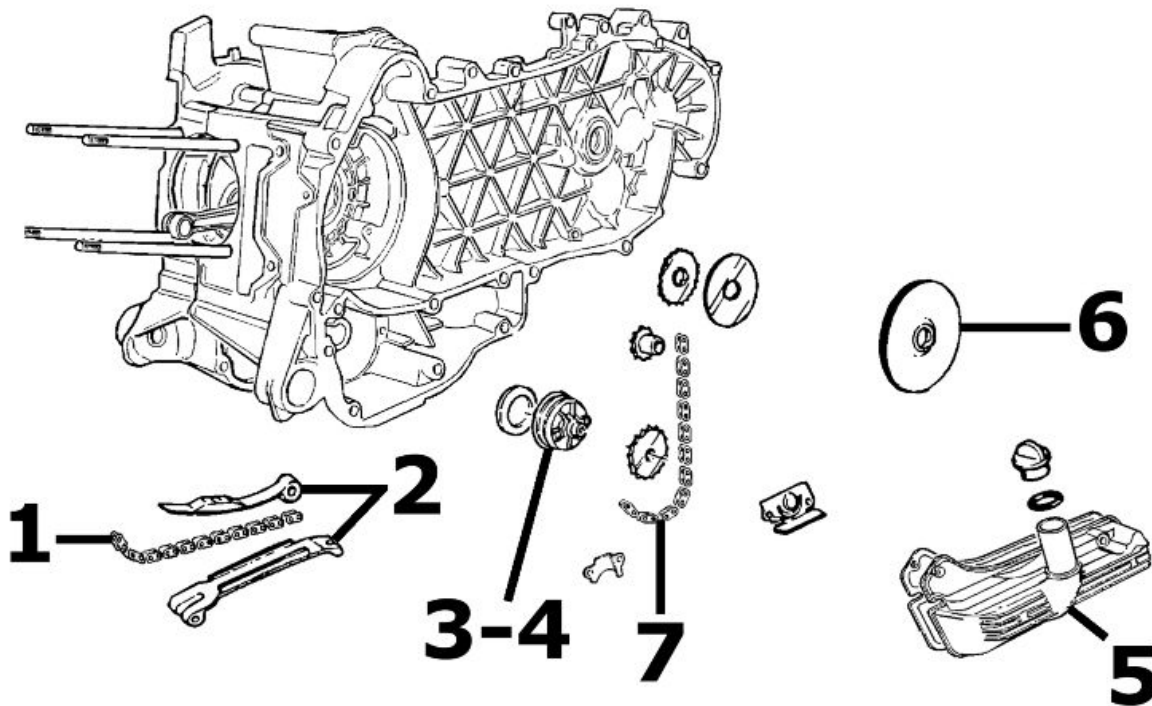
**OIL PUMP**

	Code	Action	Duration
1	001051	Belt/Timing chain - Change	
2	001125	Chain guide pads - Replacement	
3	001042	Oil pump - Service	
4	001112	Oil pump - change	
5	001130	Oil sump - Replacement	
6	001100	Oil seal, clutch side - Replacement	
7	001122	Oil pump chain - Replacement	

Final gear assy.

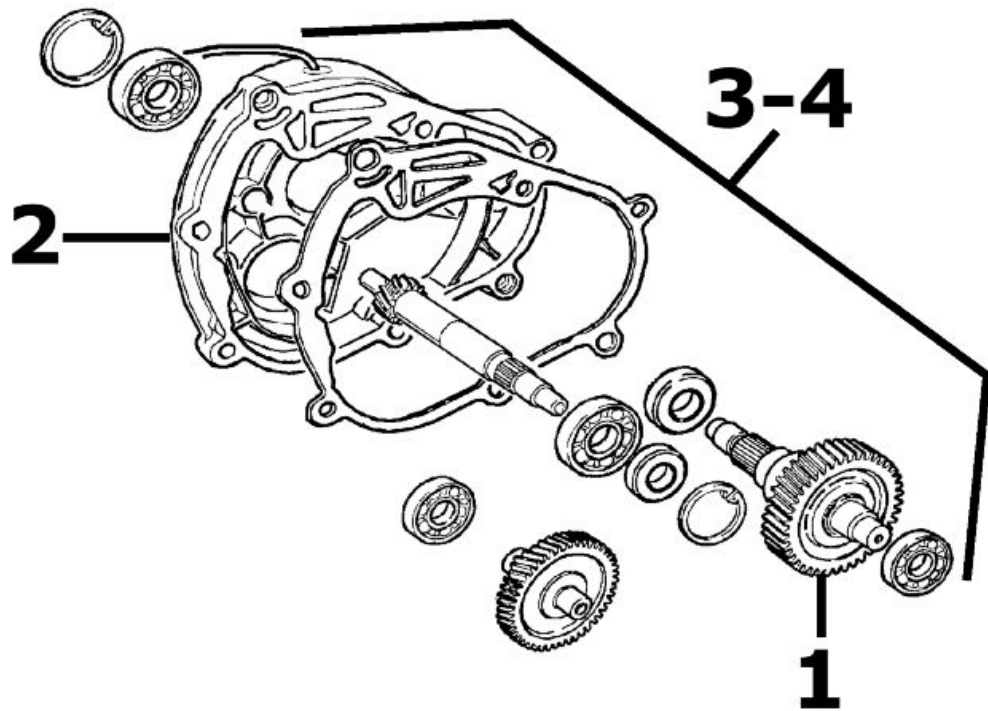

FINAL REDUCTION GEAR ASSEMBLY

	Code	Action	Duration
1	004125	Rear wheel axle - Replacement	
2	001156	Gear reduction unit cover - Replacement	
3	003065	Gear box oil - Replacement	
4	001010	Gear reduction unit - Inspection	

Driving pulley

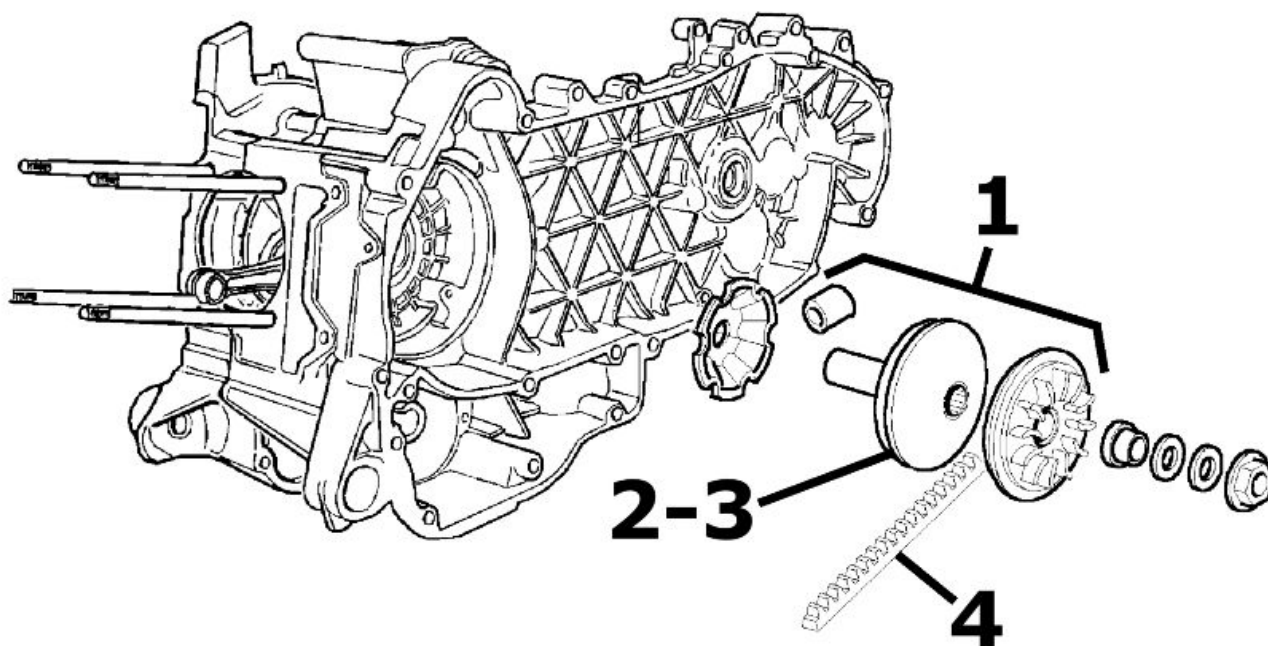

DRIVING PULLEY

	Code	Action	Duration
1	001066	Drive pulley - Removal and refitting	
2	001086	Driving half-pulley - Replacement	
3	001177	Variator rollers / shoes - Replacement	
4	001011	Driving belt - Replacement	

Transmission cover

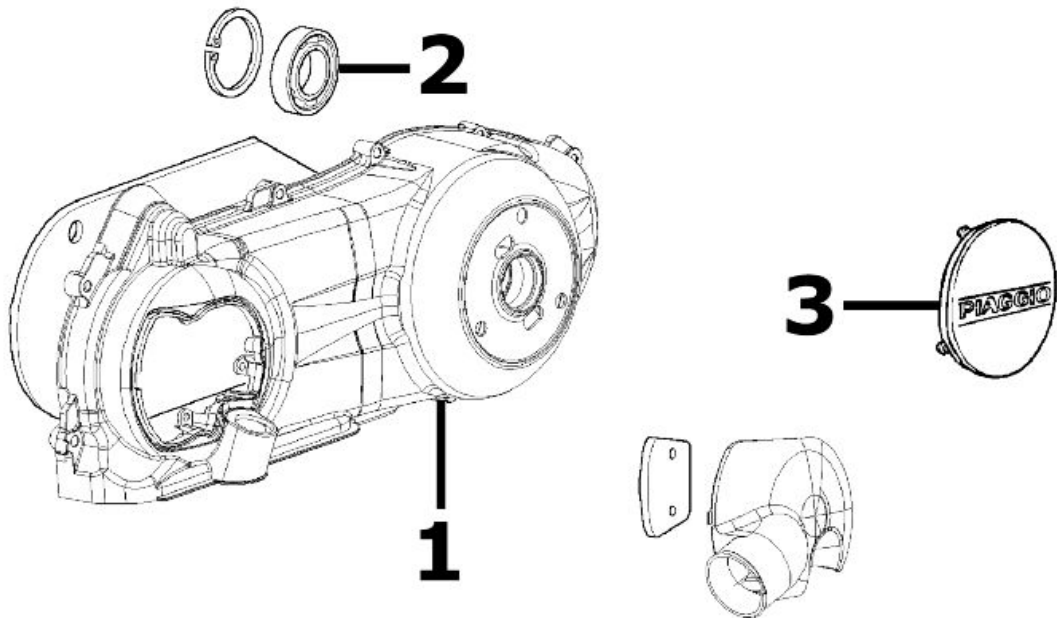

TRANSMISSION COVER

	Code	Action	Duration
1	001096	Transmission crankcase cover - Replacement	
2	001135	Transmission cover bearing - Replacement	
3	001065	Transmission cover - Removal and Refit	

Starter motor

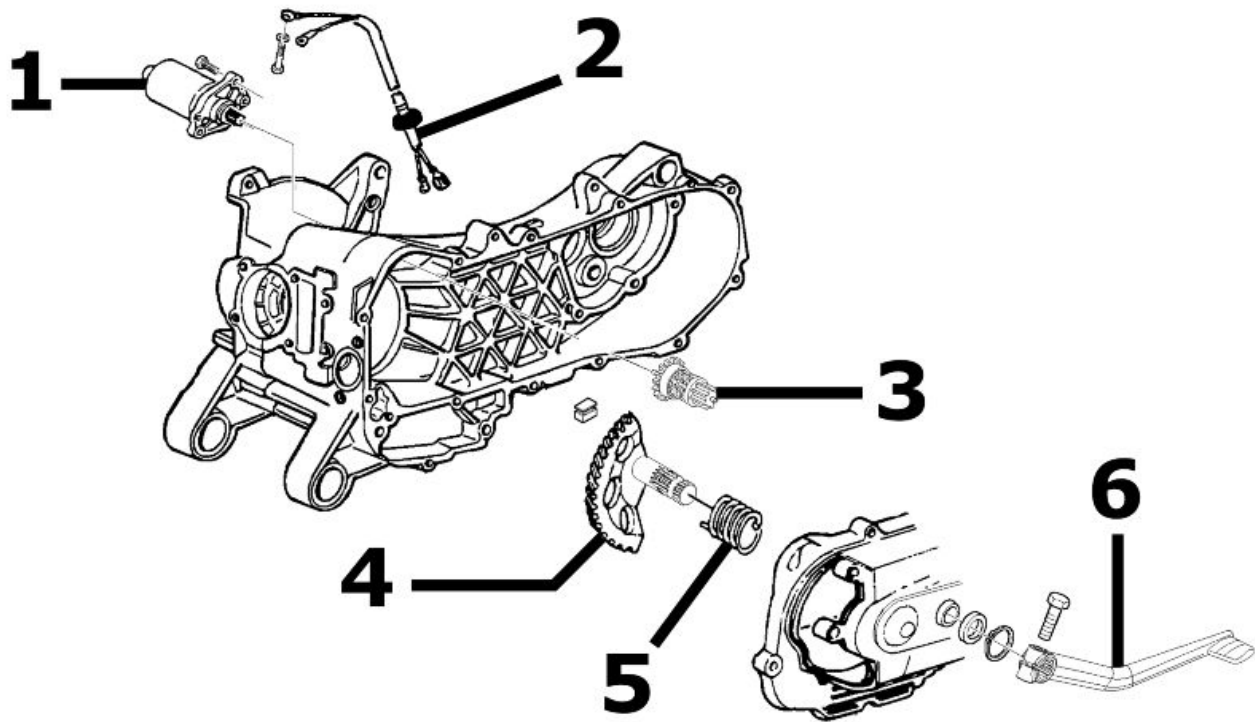

ELECTRICAL START-UP

	Code	Action	Duration
1	001020	Starter motor - Replacement	
2	005045	Starter motor cable harness - Replacement	
3	001017	Starter sprocket wheel - Replacement	
4	001021	Kick starter - Inspection	
5	008008	Starter spring pack - Replacement	
6	001084	Starter lever - Replacement	

Flywheel magneto

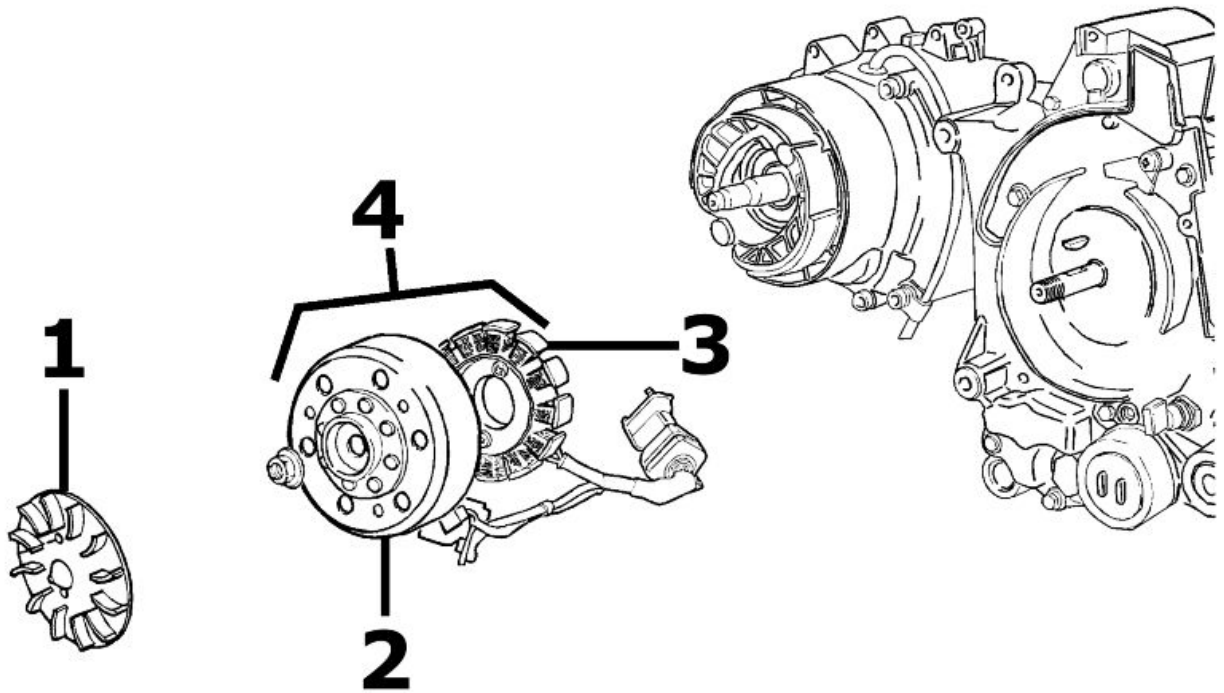

MAGNETO FLYWHEEL

	Code	Action	Duration
1	001109	Cooling fan - Replacement	
2	001173	Rotor - Replacement	
3	001067	Stator - Removal and Refitting	
4	001058	Flywheel - Replacement	

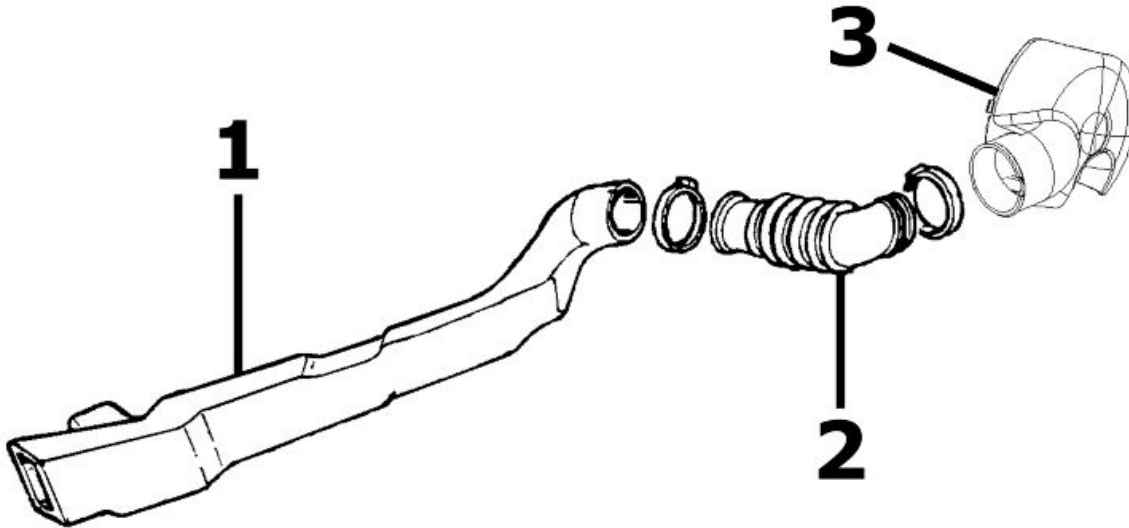
Belt cooling duct**BELT COOLING PIPE**

	Code	Action	Duration
1	001170	Air manifold - replacement	
2	001132	Transmission air inlet pipe - Replacement	
3	001131	Transmission air intake - Replacement	

Carburettor

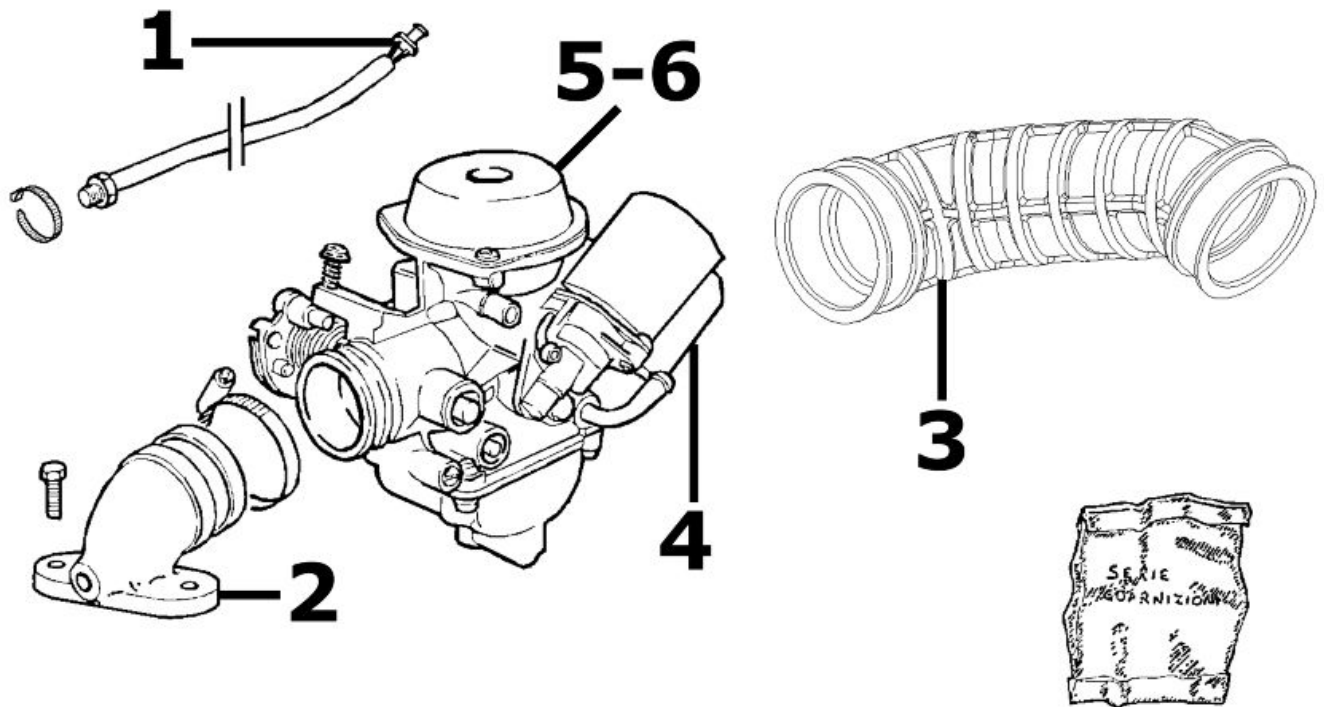

CARBURETTOR

	Code	Action	Duration
1	001082	Carburettor heating resistor - Replacement	
2	001013	Intake manifold - change	
3	004122	Air cleaner carburettor fitting - Replacement	
4	001081	Automatic choke - Replacement	
5	001008	Carburettor - Inspection	
6	001063	Carburettor - Replacement	

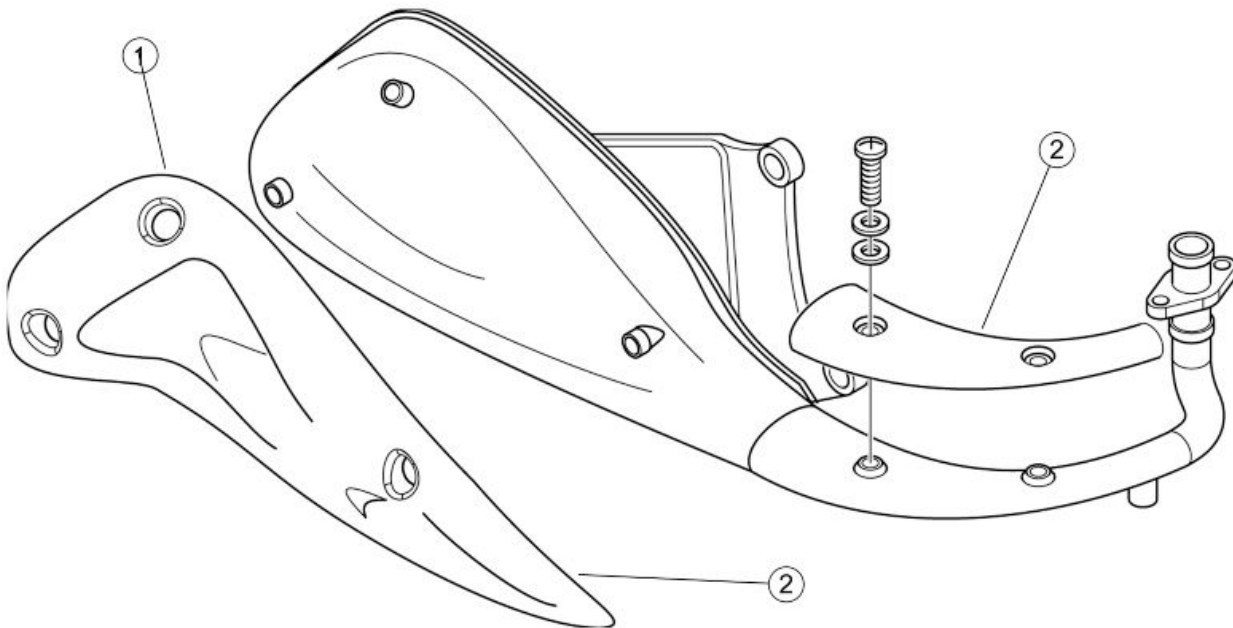
Exhaust pipe**MUFFLER**

	Code	Action	Duration
1	001009	Muffler - Replacement	
2	001095	Muffler guard - Replacement	

Air cleaner

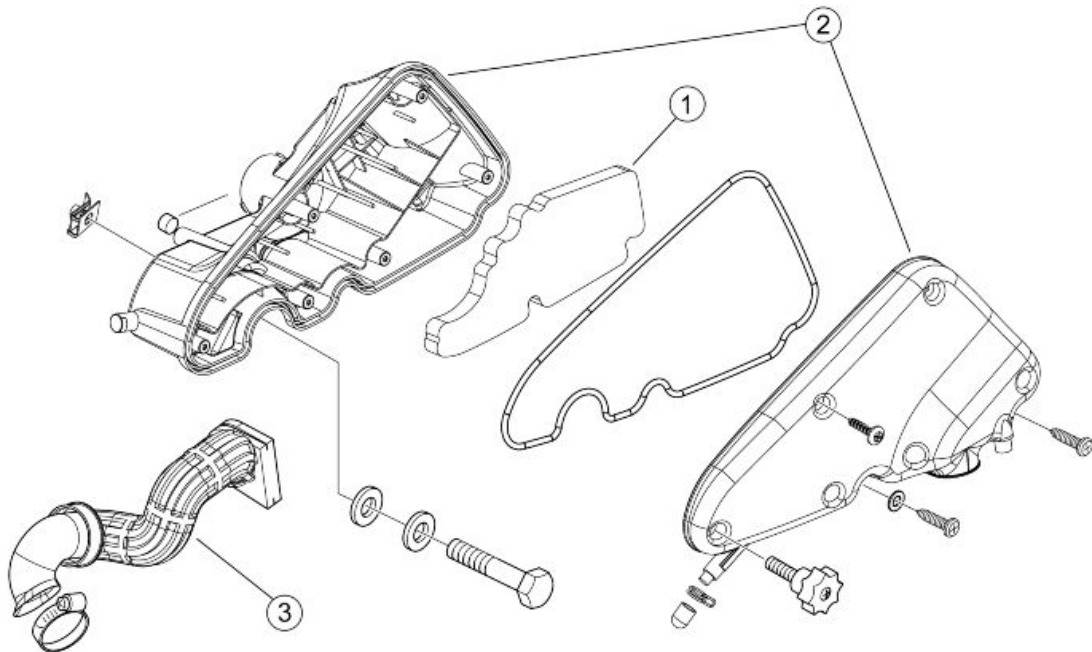

AIR CLEANER

	Code	Action	Duration
1	004122	Air cleaner carburettor fitting - Replacement	
2	001014	Air filter - Replacement/Cleaning	
3	001015	Air filter box - Replacement	
4	001027	Body / air cleaner union - Replacement	

Frame

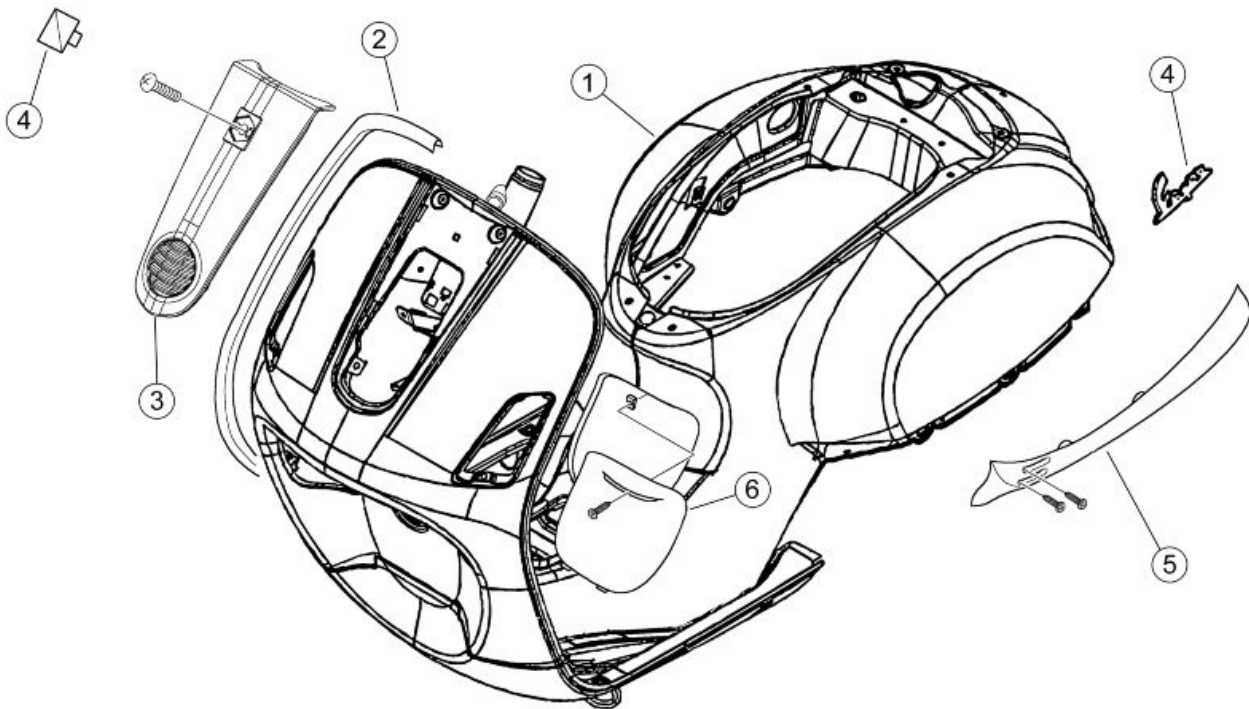

FRAME

	Code	Action	Duration
1	004001	Chassis - Replacement	
2	004023	Shield rim - Replacement	
3	004149	Shield central cover - Replacement	
4	004159	Plates / Stickers - Replacement	
5	004012	Rear side panels - Replacement	
6	004059	Spark plug inspection flap - Replacement	

Centre-stand

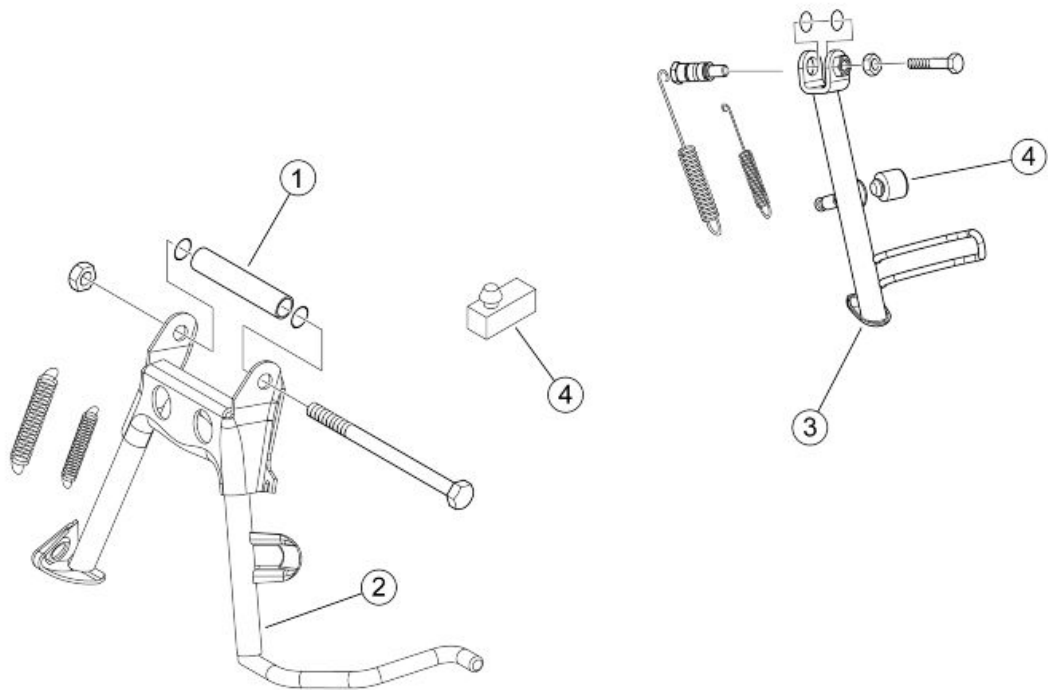

STAND

	Code	Action	Duration
1	001053	Stand bolt - Replacement	
2	004004	Stand - Replacement	
3	004102	Side stand - Replacement	
4	004179	Stand buffer - Replacement	

Footrests

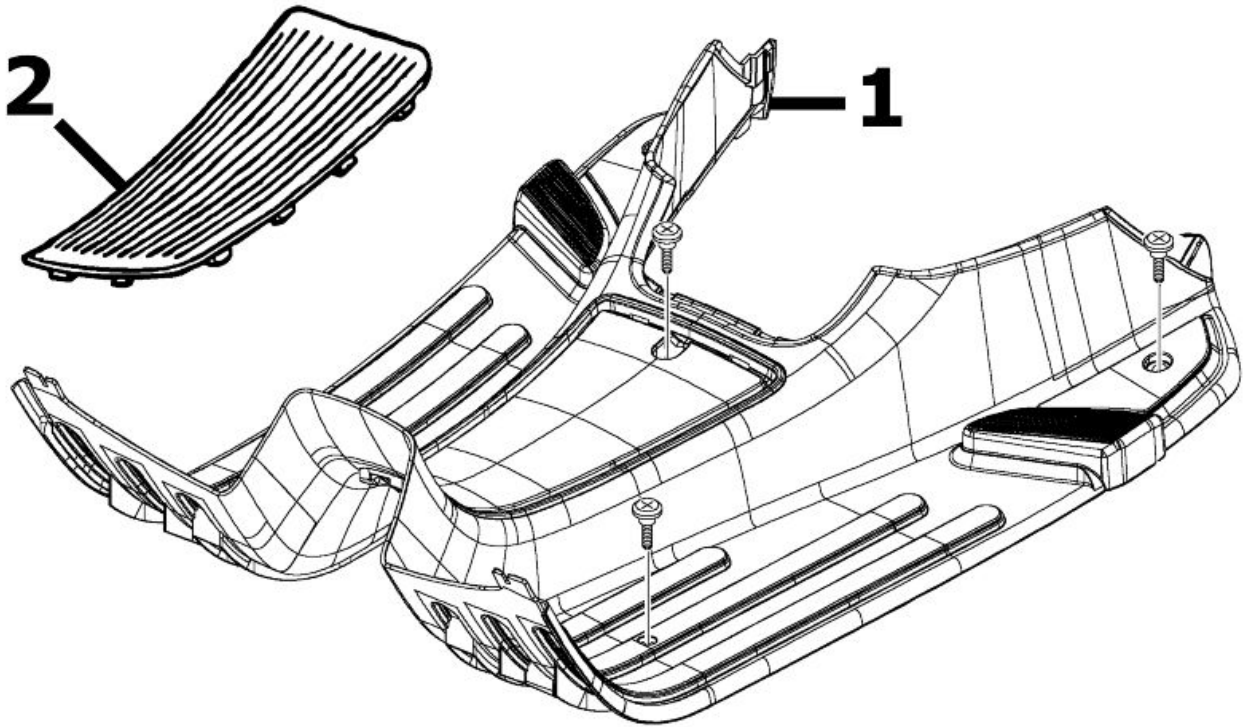
**FOOTREST**

	Code	Action	Duration
1	004178	Footrest - Replacement	
2	004078	Front/rear footrest rubber - Replacement	

Rear cover

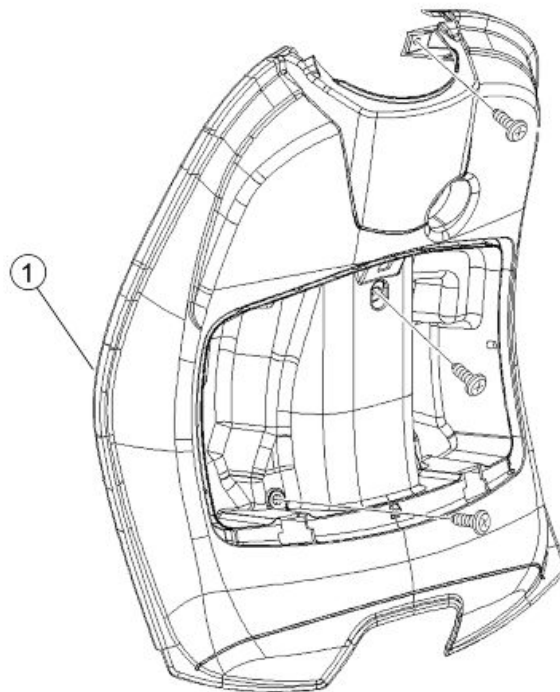

SHIELD BACK PLATE

	Code	Action	Duration
1	004065	Front shield, rear part - Removal and refitting	

Underseat compartment

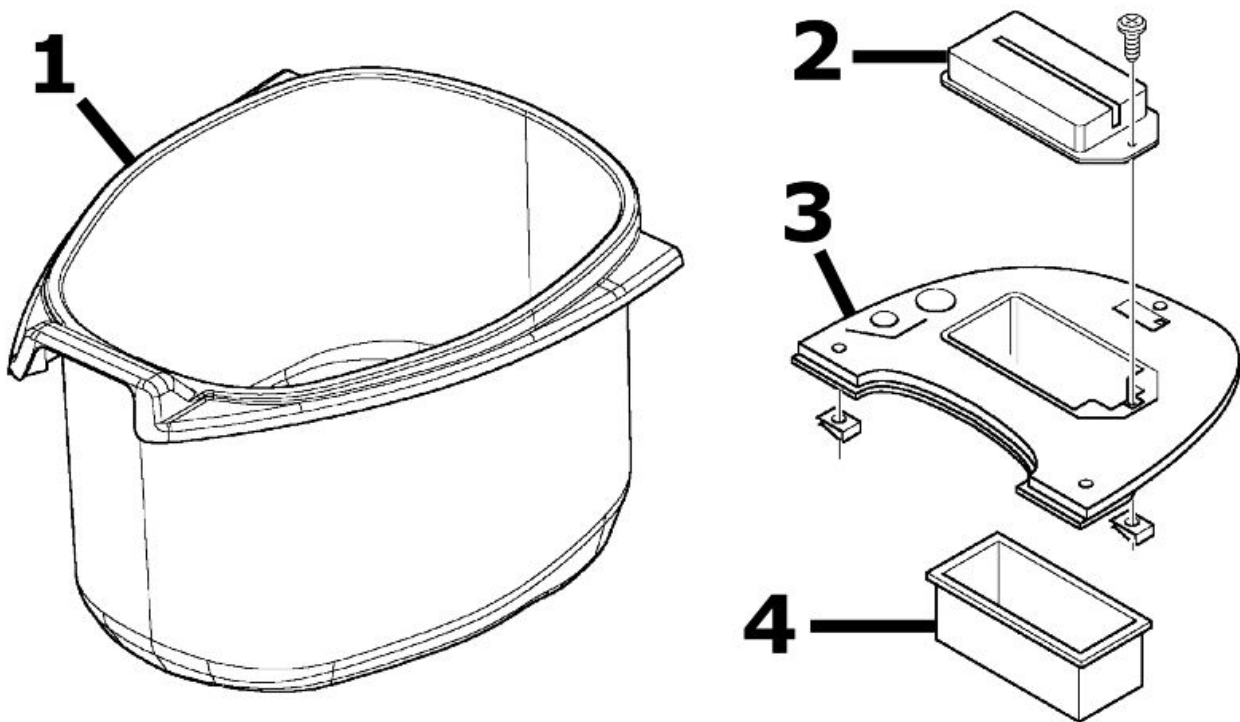

HELMET COMPARTMENT

	Code	Action	Duration
1	004016	Helmet compartment - Replacement	
2	005046	Battery cover - change	
3	004011	Central chassis cover - Replacement	
4	004071	Battery compartment - replacement	

Plate holder

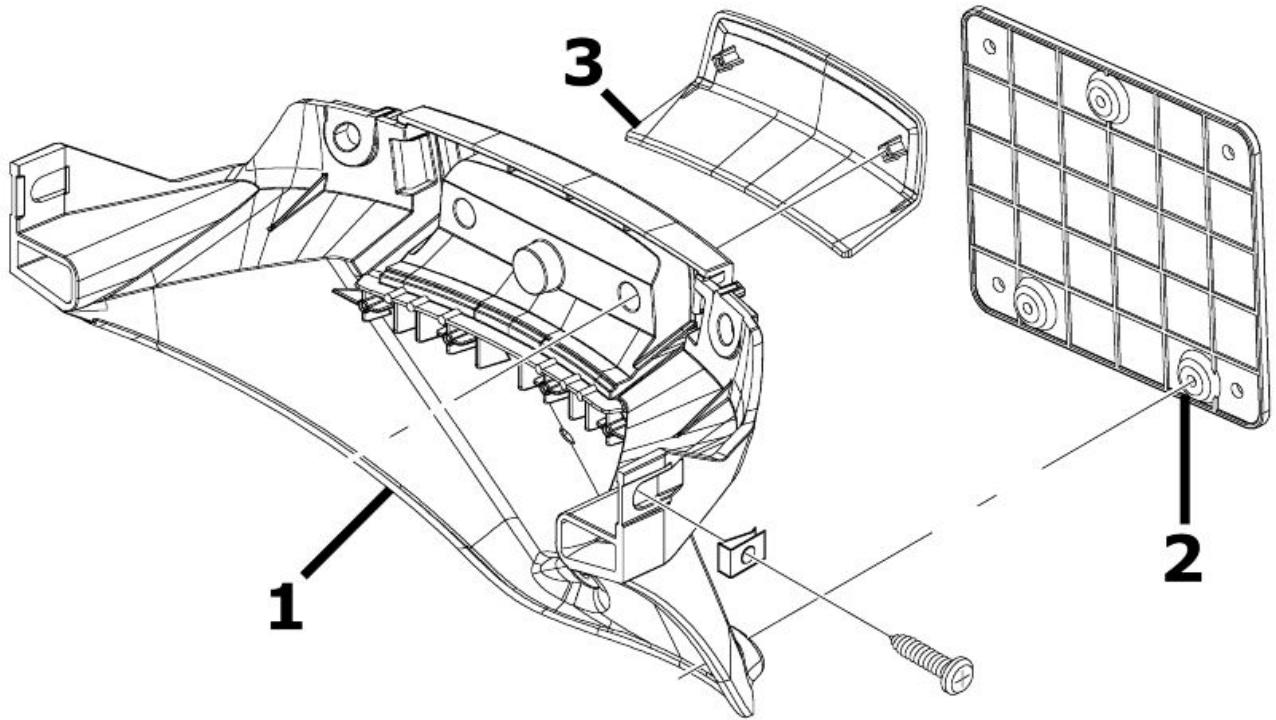

LICENSE PLATE HOLDER

	Code	Action	Duration
1	004136	License plate support - Replacement	
2	005048	Licence plate holder - Replacement	
3	005032	Licence plate light glass - Replacement	

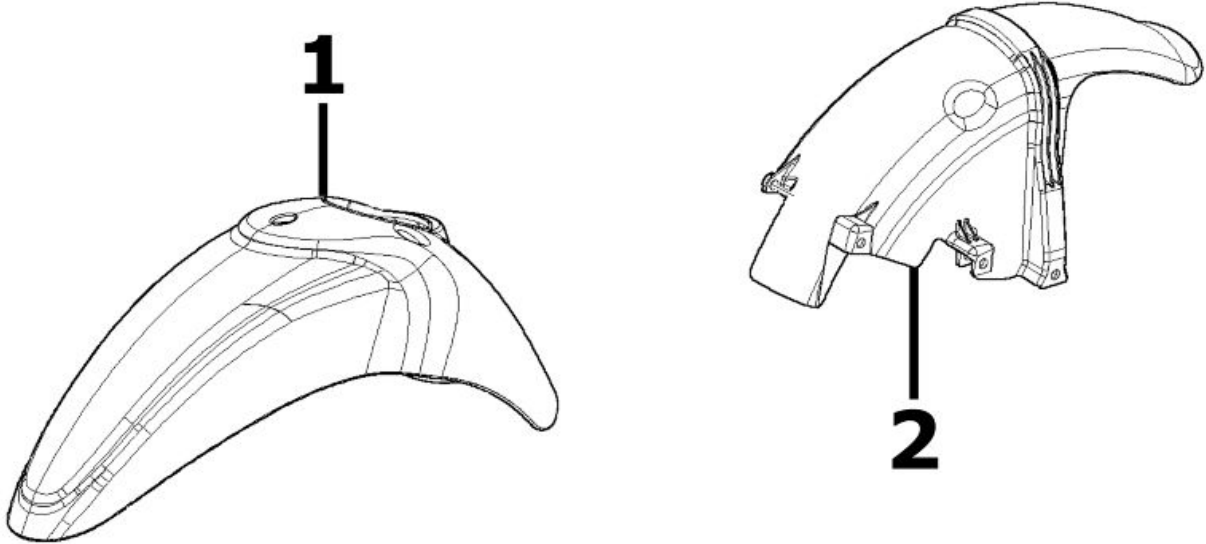
Mudguard**MUDGUARDS**

	Code	Action	Duration
1	004002	Front mudguard - Replacement	
2	004009	Rear mudguard - Replacement	

Fuel tank

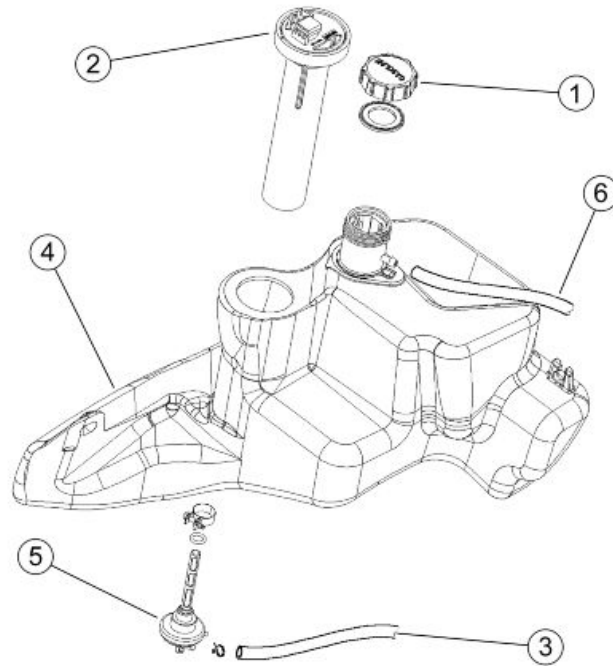

FUEL TANK

	Code	Action	Duration
1	004168	Fuel tank cap - Replacement	
2	005010	Tank float - Replacement	
3	004112	Cock-carburettor hose - Replacement	
4	004005	Fuel tank - Replacement	
5	004007	Fuel valve - Replacement	
6	004109	Fuel tank breather - Replacement	

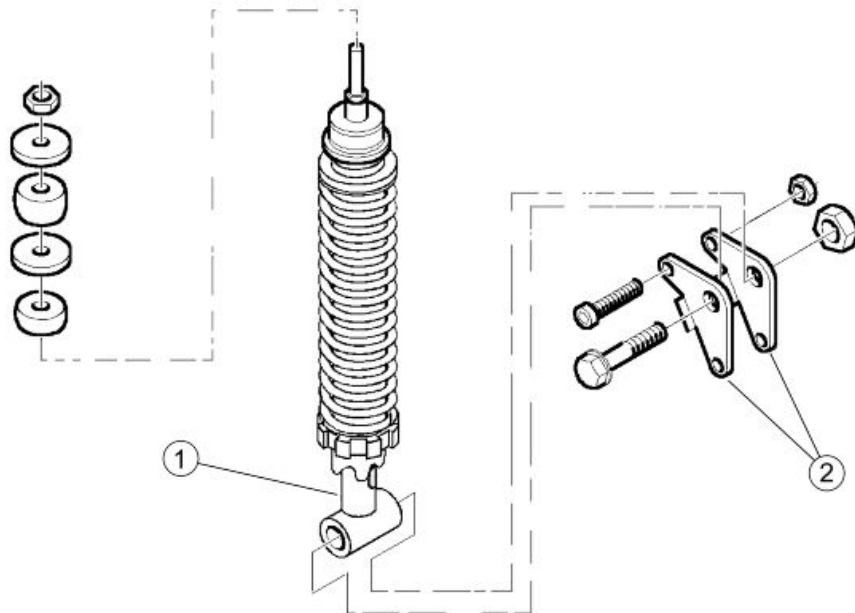
Rear shock-absorber**REAR SHOCK ABSORBER**

	Code	Action	Duration
1	003007	Rear shock absorber - Removal and Refitting	
2	003085	Suspension strut - Replacement	

Steering column bearings

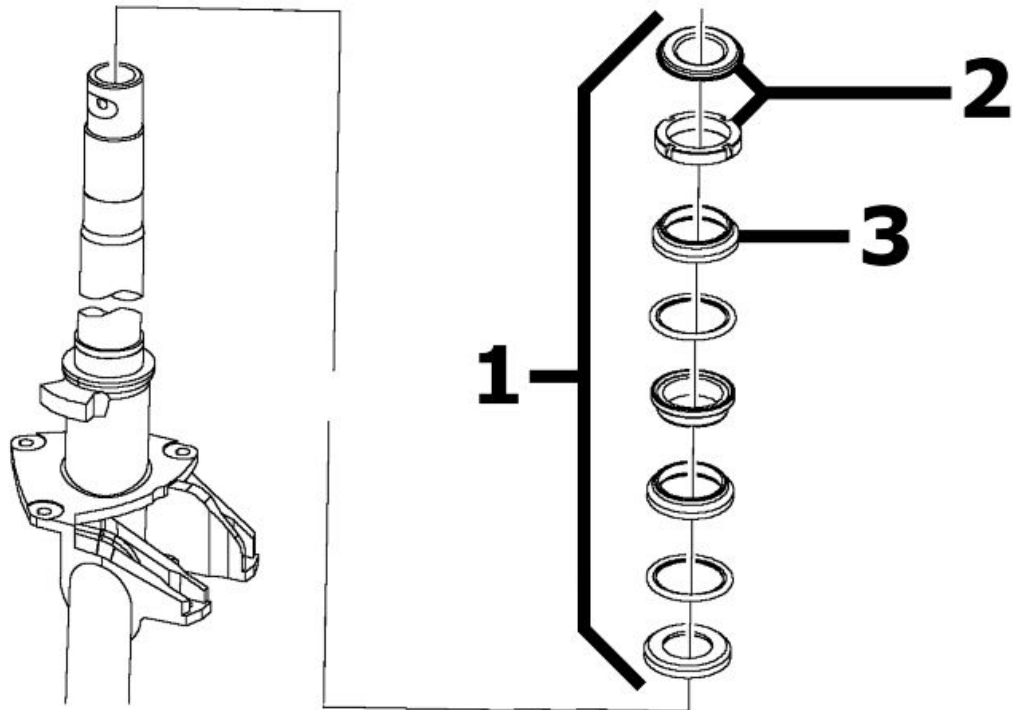

STEERING FIFTH WHEELS

	Code	Action	Duration
1	003002	Steering fifth wheel - Replacement	
2	003073	Steering clearance - Adjustment	
3	004119	Bearing / upper steering fifth wheel - Replacement	

Handlebar covers

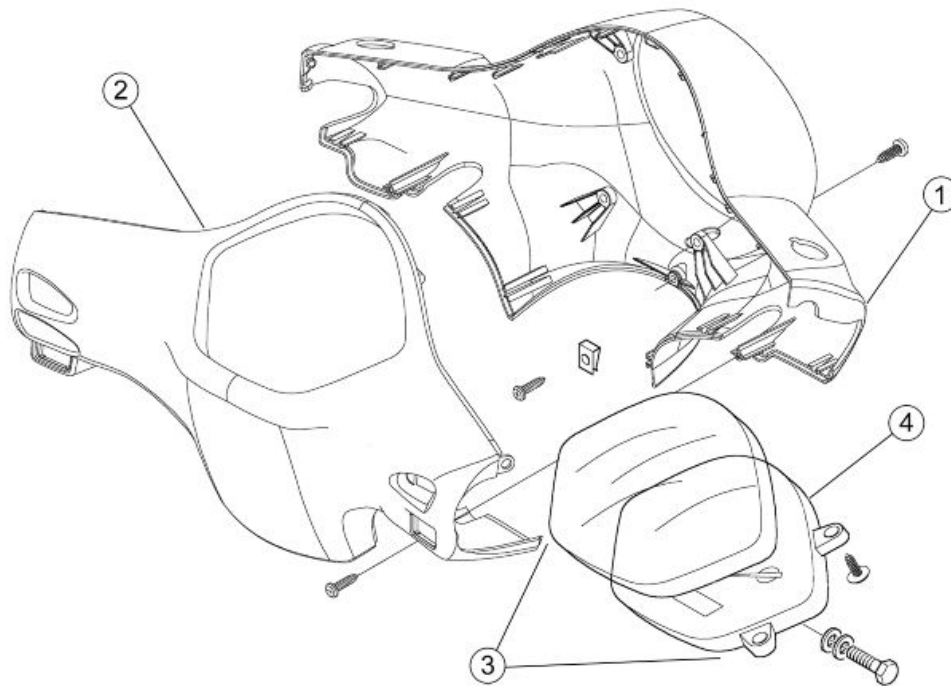

ODOMETER - HANDLEBAR COVER

	Code	Action	Duration
1	004018	Handlebar front section - Replacement	
2	004019	Handlebar rear section - Replacement	
3	005014	Odometer - Replacement	
4	005038	Instrument panel warning light bulbs - Replacement	

Handlebar components

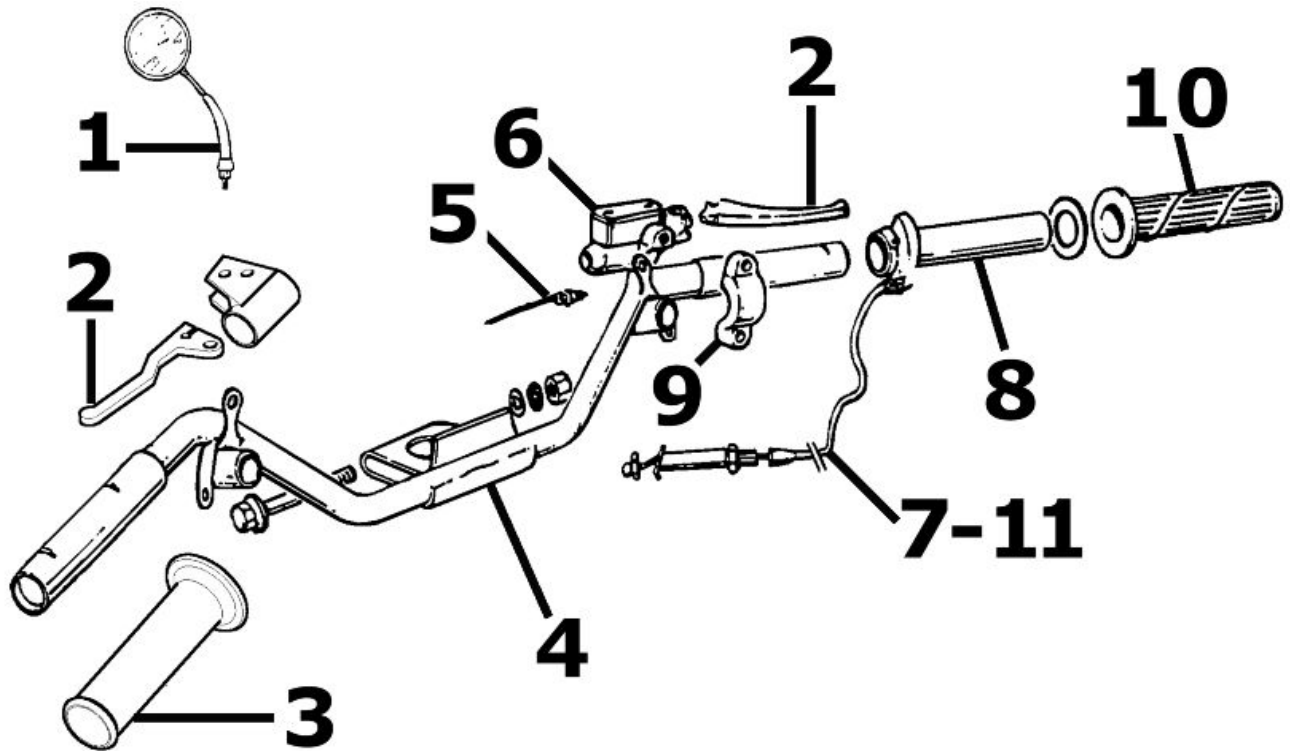

HANDLEBAR COMPONENTS

	Code	Action	Duration
1	004066	Driving mirror - Replacement	
2	002037	Brake or clutch lever - Replacement	
3	002071	Left hand grip - Replacement	
4	003001	Handlebar - Removal and refitting	
5	005017	Stop switch - Replacement	
6	002024	Front brake pump - Removal and Refitting	
7	003061	Accelerator transmission - Adjustment	
8	002060	Complete throttle control - Replacement	
9	004162	Mirror support and/or brake pump fitting U-bolt - Replacement	
10	002059	Right hand grip - Replacement	
11	002063	Throttle control transmission - Replacement	

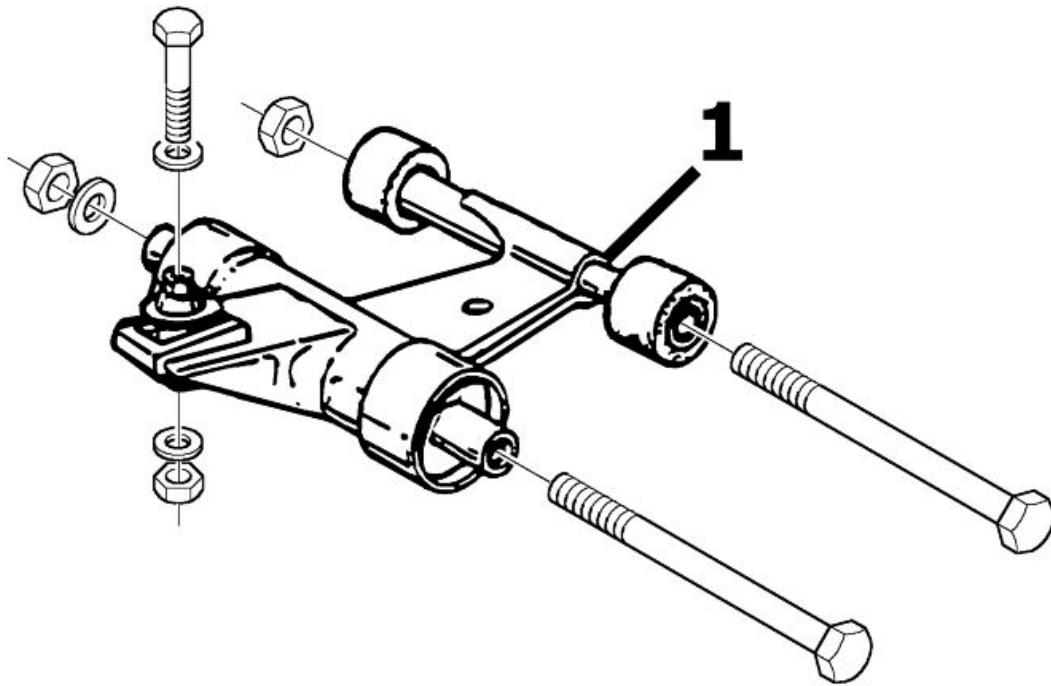
Swing-arm**SWINGING ARM**

	Code	Action	Duration
1	001072	Swinging arm - Engine-chassis connection - Replacement	

Seat

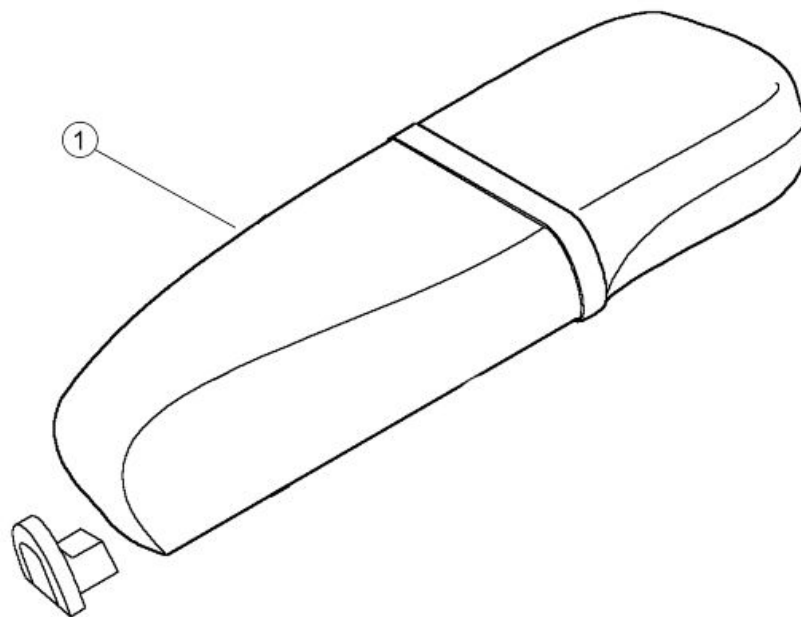

SADDLE

	Code	Action	Duration
1	004003	Saddle - Replacement	

Turn signal lights

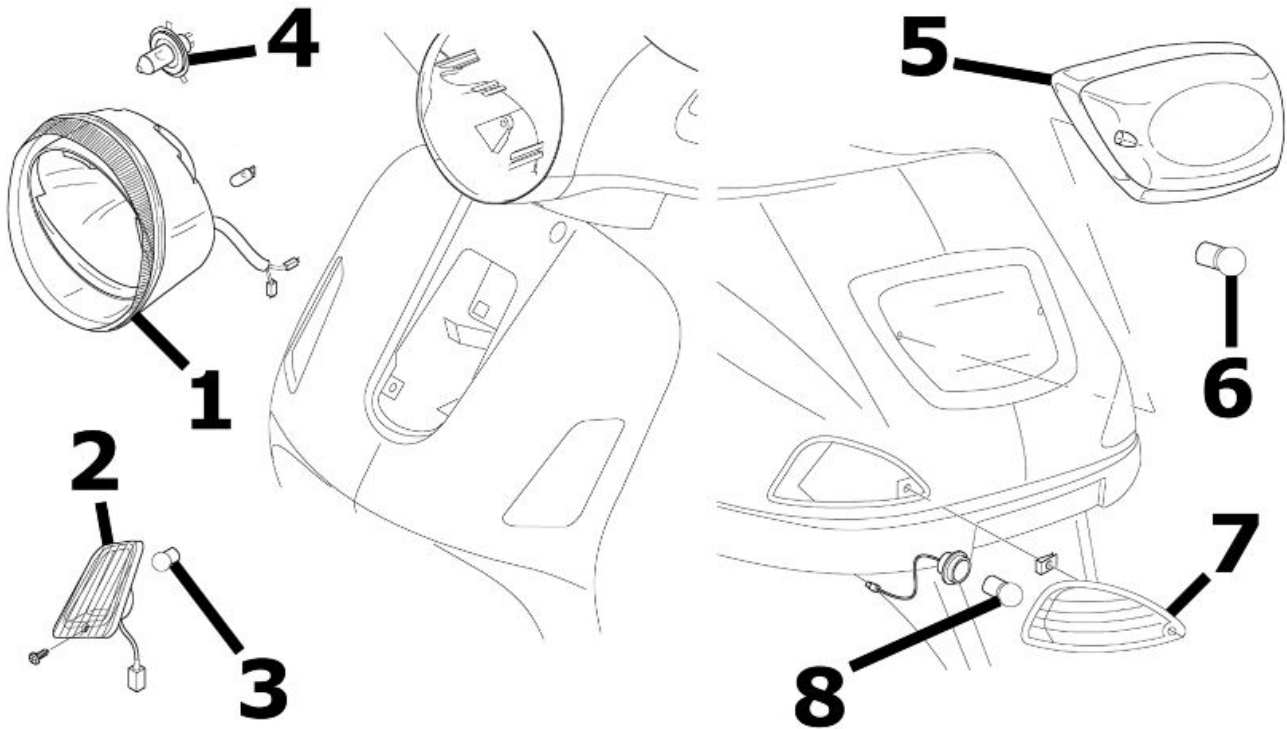
**TURN INDICATOR LIGHTS**

	Code	Action	Duration
1	005002	Front headlamp - Replacement	
2	005012	Front turn indicator - Replacement	
3	005067	Front turn indicator bulb - Replacement	
4	005008	Front headlamp bulbs - Replacement	
5	005005	Taillight - Replacement	
6	005066	Rear light bulbs - Replacement	
7	005022	Rear turn indicators - Replacement	
8	005068	Rear turn indicator bulb - Replacement	

Front wheel

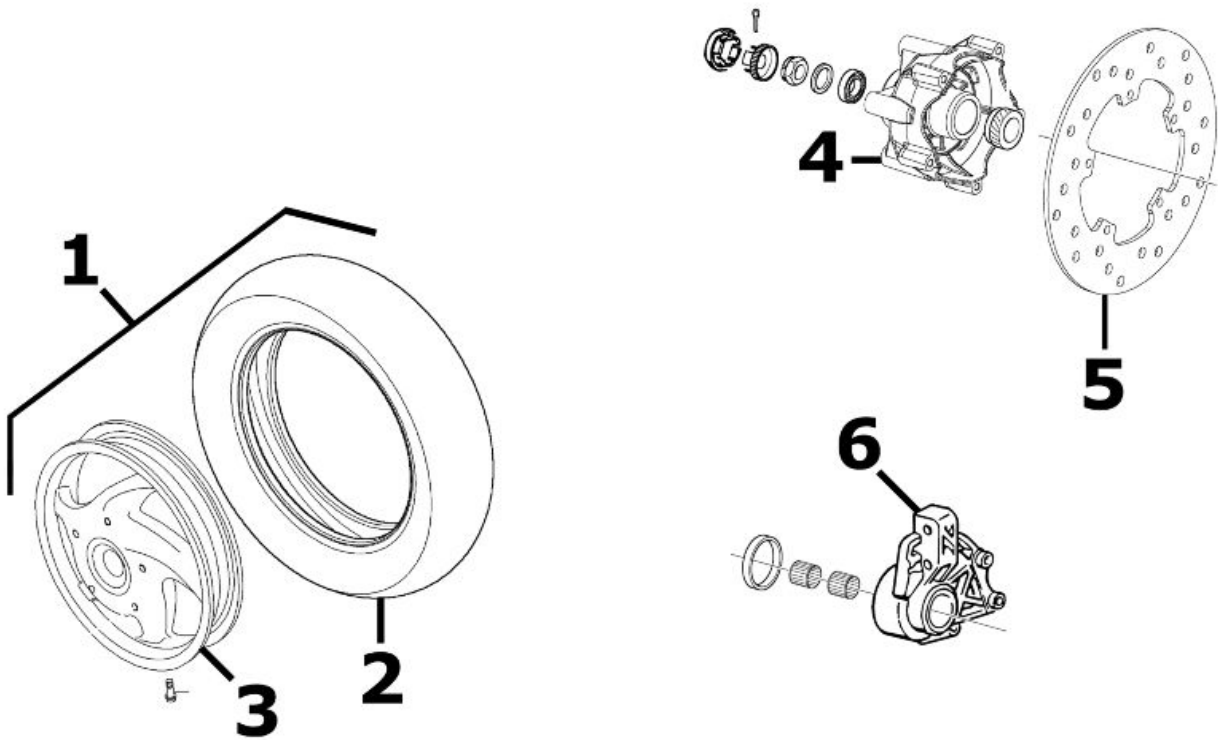

FRONT WHEEL

	Code	Action	Duration
1	004123	Front wheel - Replacement	
2	003047	Front tyre - replace	
3	003037	Front wheel rim- Replacement	
4	003033	Front wheel hub- Replacement	
5	002041	Front brake disc - Replacement	
6	003034	Front wheel hub bearing - Replacement	

Rear wheel

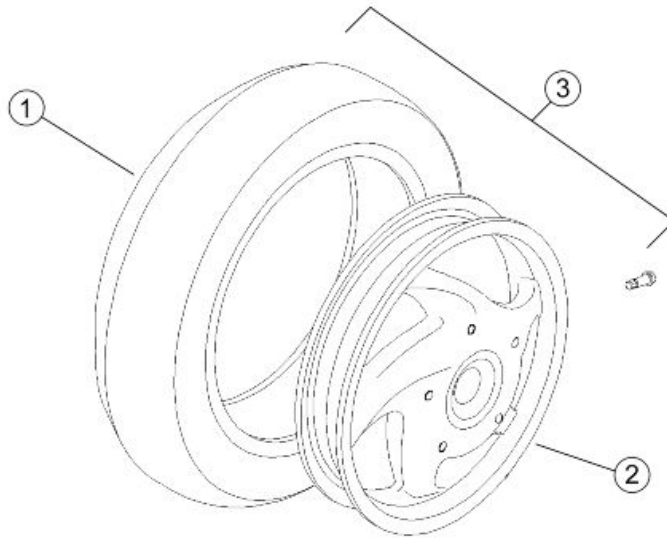

REAR WHEEL

	Code	Action	Duration
1	004126	Rear wheel tyre - Replacement	
2	001071	Rear wheel rim - Removal and Refitting	
3	001016	Rear wheel - Replacement	

Fuel pump

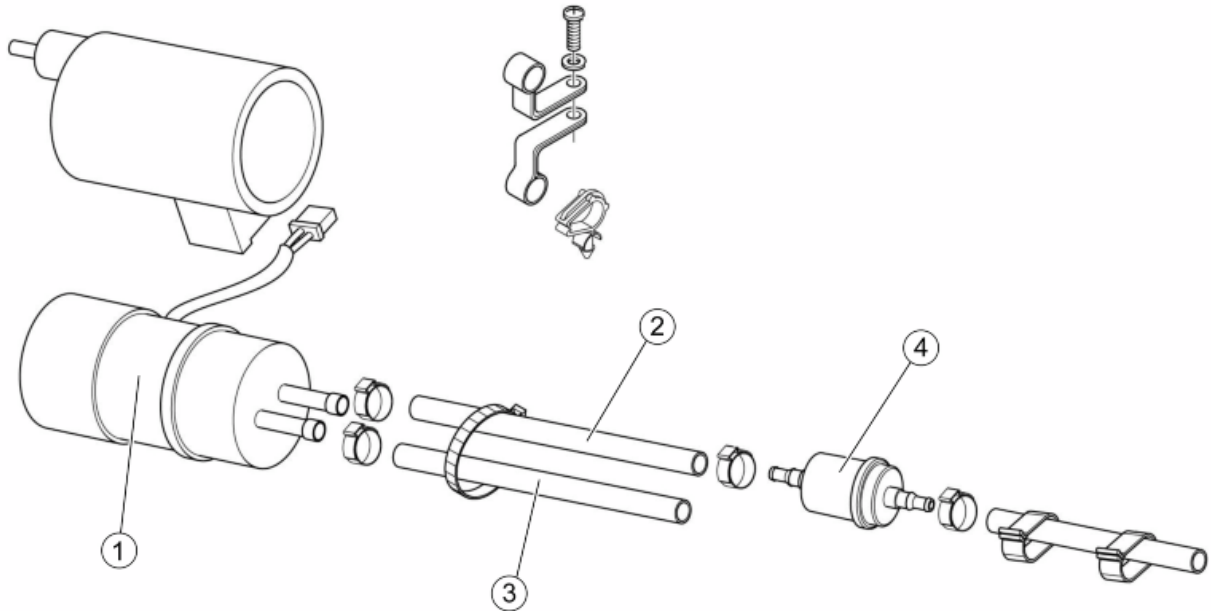

FUEL PUMP

	Code	Action	Duration
1	004073	Fuel pump - Replacement	
2	004089	Tank-pump hose - Replacement	
3	004137	Carburettor pump hose - Replacement	
4	004072	Fuel filter - Replacement	

Electric devices

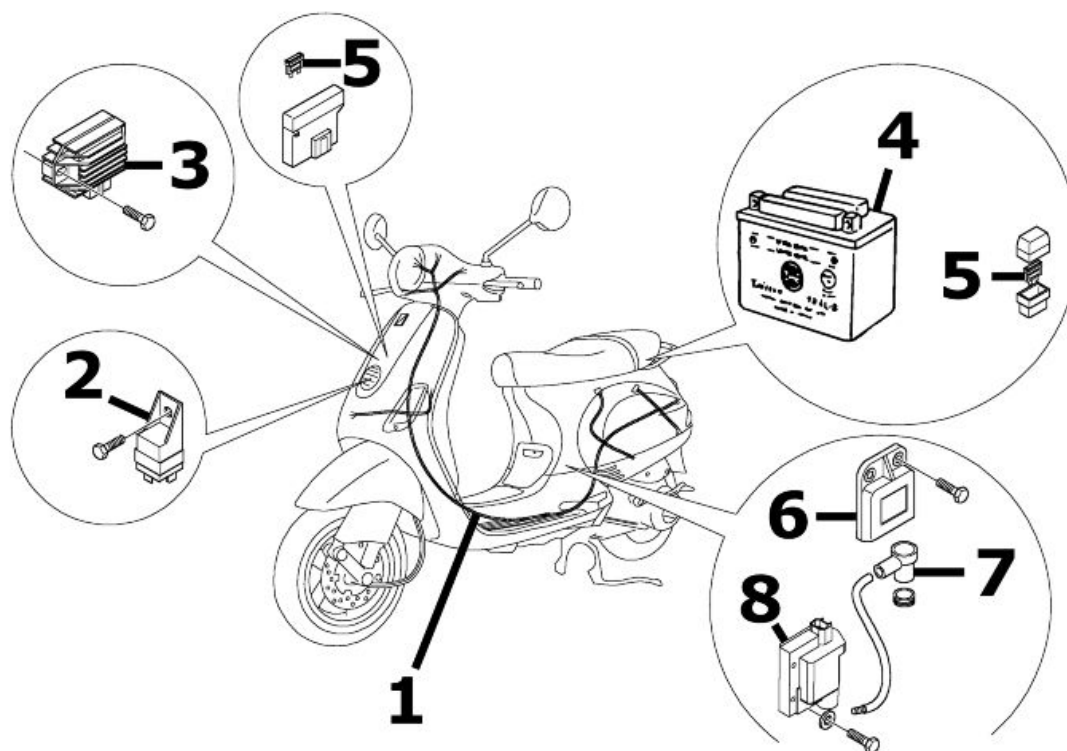
**ELECTRICAL COMPONENTS**

	Code	Action	Duration
1	005001	Electrical system - Replacement	
2	005011	Start-up remote control switch - Replacement	
3	005009	Voltage regulator - Replacement	
4	005007	Battery - Replacement	
5	005052	Fuse (1) - Replacement	
6	001023	Control unit - Replacement	
7	001094	Spark plug cap - Replacement	
8	001069	HV coil - Replacement	

Electronic controls

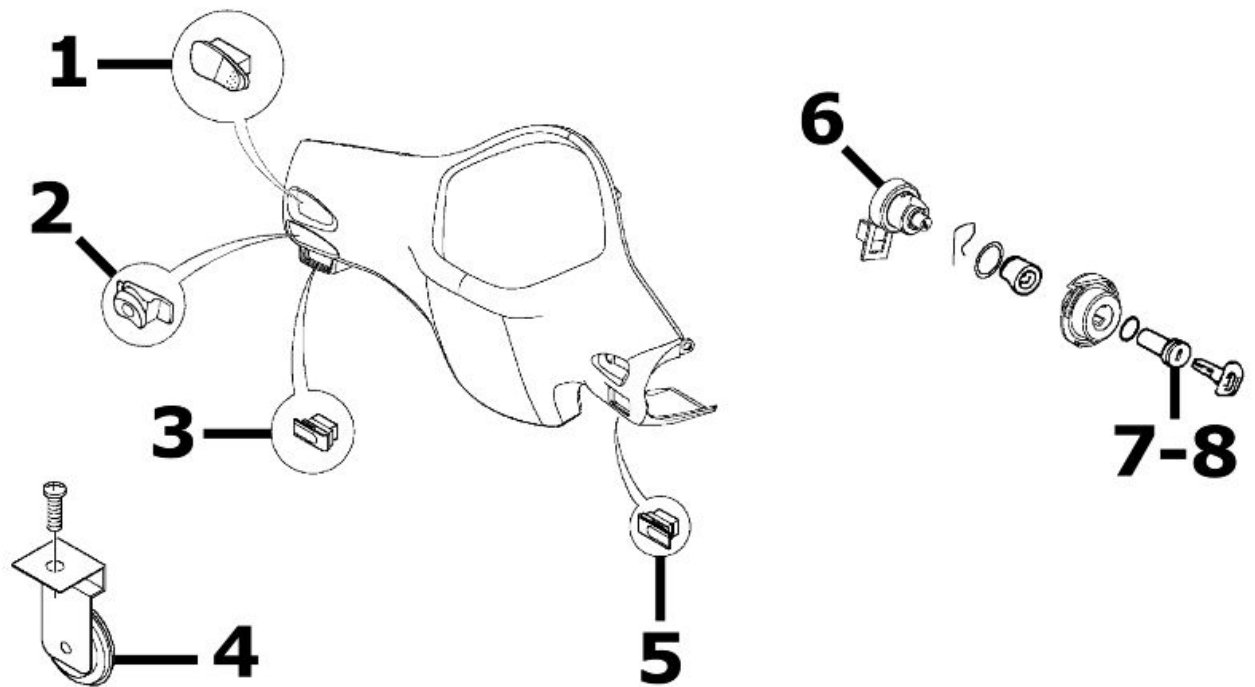

ELECTRICAL CONTROLS

	Code	Action	Duration
1	005039	Headlight switch - Replacement	
2	005006	Light switch or turn indicators - Replacement	
3	005040	Horn button - Replacement	
4	005003	Horn - Replacement	
5	005041	Starter button - Replacement	
6	005016	Key switch - Replacement	
7	004096	Lock series - Replacement	
8	004010	Anti-theft lock - Replacement	

Transmissions

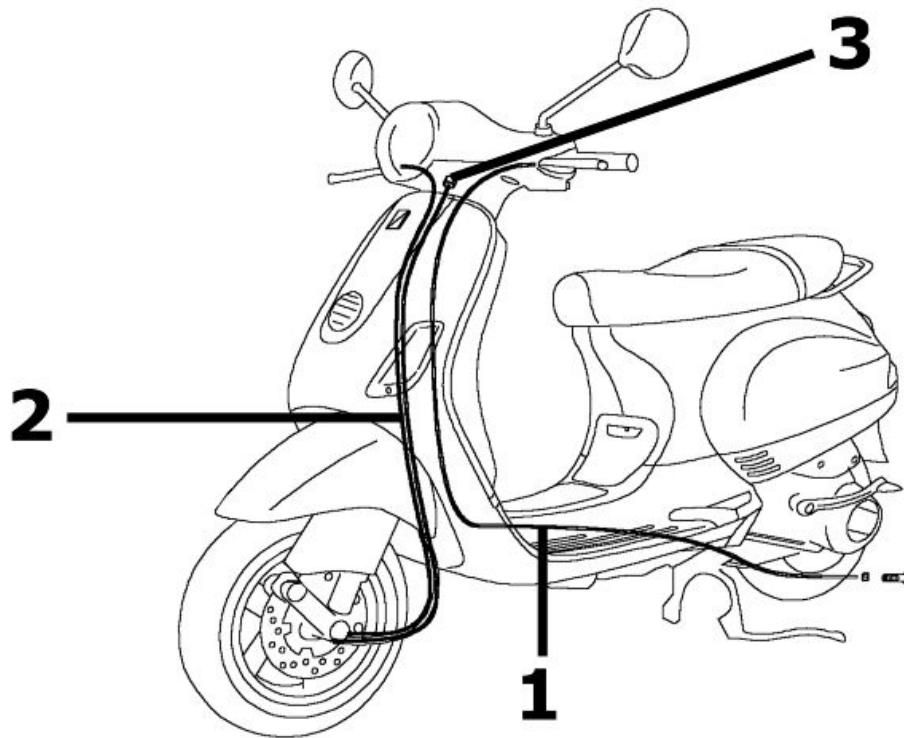

TRANSMISSIONS

	Code	Action	Duration
1	002053	Rear brake transmission complete - Replacement	
2	002051	Odometer transmission assembly - Replacement	
3	002049	Odometer cable - Replacement	

Front suspension

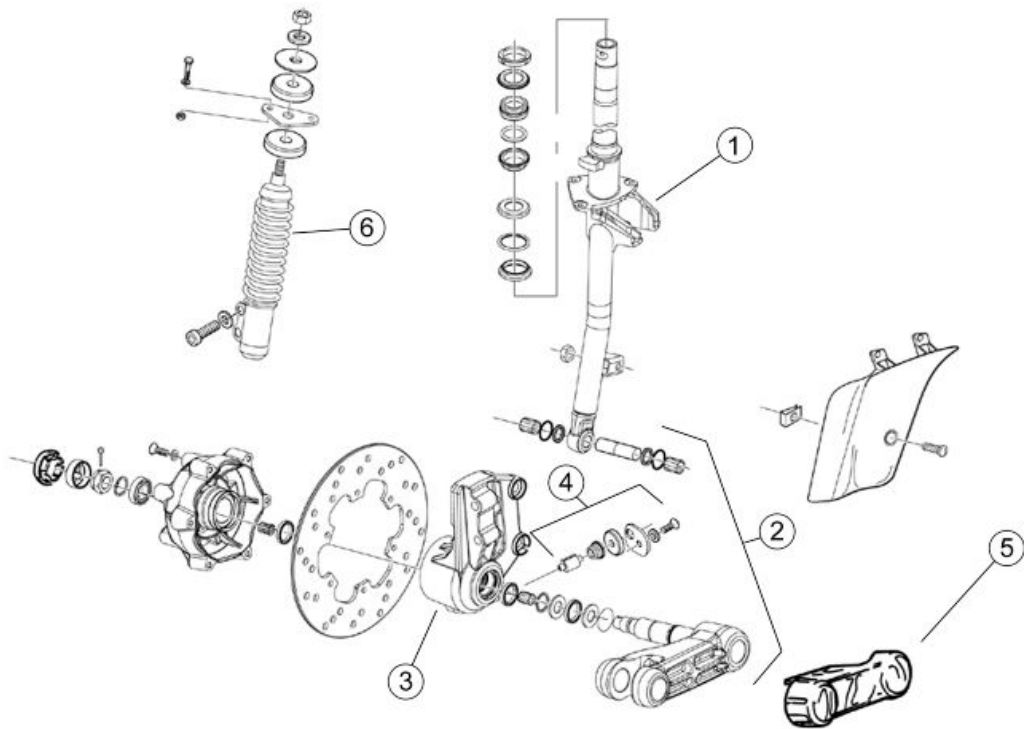

FRONT SUSPENSION

	Code	Action	Duration
1	003045	Steering tube - Replacement	
2	003010	Front suspension - Service	
3	003035	Shock absorber support and brake calliper - Replacement	
4	001064	Odometer reel - Replacement	
5	003044	Shock absorber cover - Replacement	
6	003011	Front shock absorber - Removal and Refitting	

Braking system

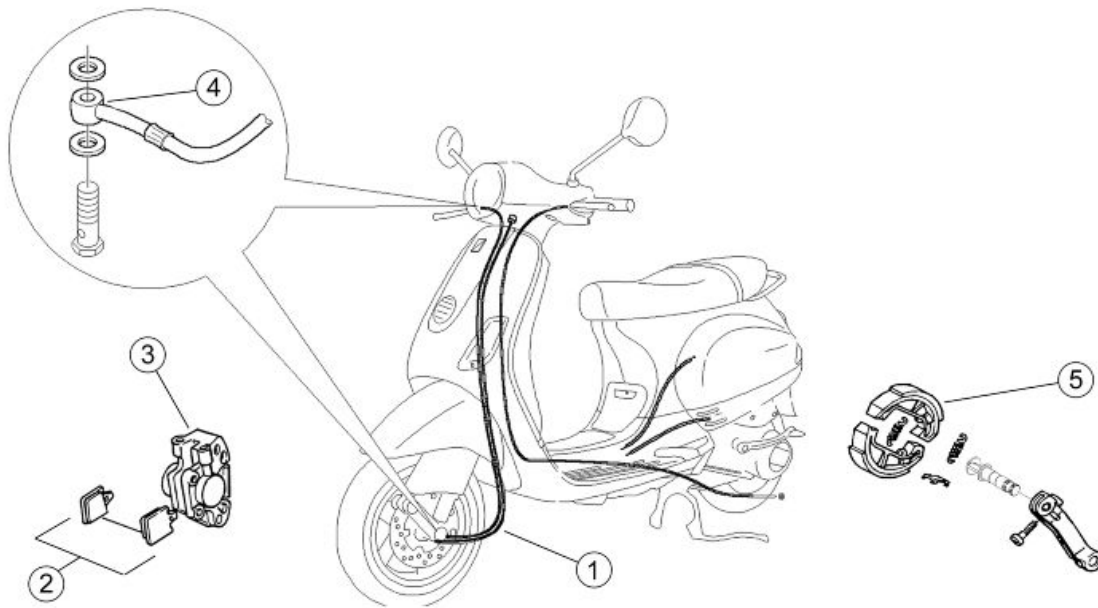

BRAKING SYSTEM

	Code	Action	Duration
1	002021	Front brake hose - Remov. and Re-fitt.	
2	002007	Front brake shoes/pads - Remov. and Refitt	
3	002039	Front brake calliper - Removal and Refitting	
4	002047	Front brake fluid and air bleeding system - Replacement	
5	002002	Shoes - Rear brake pads - Replacement	

Secondary air box

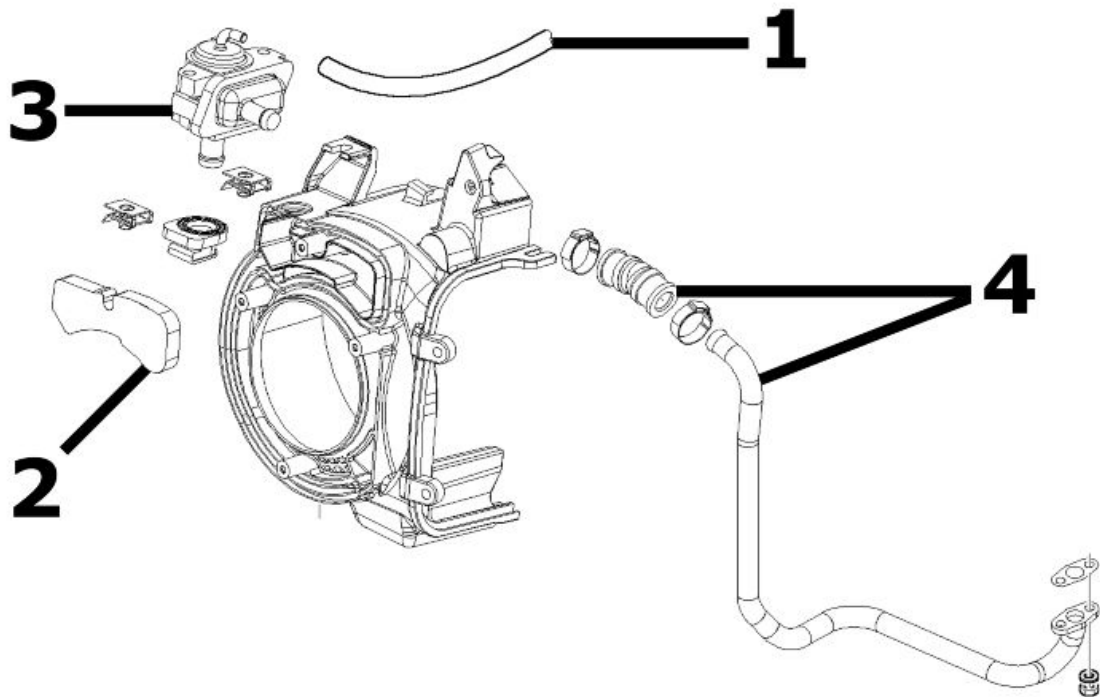

SECONDARY AIR SYSTEM

	Code	Action	Duration
1	001164	Crankcase secondary air connection - Replacement	
2	001161	Secondary air filter - Replacement / Cleaning	
3	001174	SAS valve - Replacement	
4	001163	Muffler secondary air connection - Replacement	

A

Air filter: 35, 186

B

Battery: 48, 59, 65, 68

Brake: 172, 174, 176, 178

Brake fluid: 176

C

Carburettor: 11, 138, 143, 213

E

Engine oil: 35

F

Fuel: 39, 47, 136, 187, 223, 233

H

Headlight: 42, 183

Hub oil: 33

I

Identification: 8

Instrument panel: 182

M

Maintenance: 7, 29

O

Odometer:

Oil filter: 38, 203

S

Saddle:

Shock absorbers: 169

Spark plug: 32, 63

Stand: 170

Start-up:

T

Tank: 187, 223

Transmission: 9, 47, 80, 93, 104, 209

Turn indicators:

Tyres: 10