

HOW TO USE THIS MANUAL

Follow the Maintenance Schedule (Section 3) recommendations to ensure that the scooter is in peak operating condition and the emission levels are within the standards set by the U.S. Environmental Protection Agency and the California Air Resources Board. Performing the first scheduled maintenance is very important. It compensates for the initial wear that occurs during the break-in period.

Sections 1 through 3 apply to the whole scooter, while sections 4 through 21 describe parts of the scooter grouped according to location.

Find the section you want on this page, then turn to the table of contents on page 1 of that section.

Most sections start with an assembly or system illustration, service information and troubleshooting for the section. The subsequent pages give detailed procedures.

If you are not familiar with this scooter, read the TECHNICAL FEATURES in section 22.

If you don't know the source of the trouble, go to section 23, TROUBLESHOOTING.

All information, illustrations, directions and specifications included in this publication are based on the latest product information available at the time of approval for printing. HONDA MOTOR CO., LTD. reserves the right to make changes at any time without notice and without incurring any obligation whatever. No part of this publication may be reproduced without written permission.

HONDA MOTOR CO., LTD.
Service Publications Office

CONTENTS

	GENERAL INFORMATION	1
	LUBRICATION	2
	MAINTENANCE	3
ENGINE	FUEL SYSTEM	4
	ENGINE REMOVAL/INSTALLATION	5
	CYLINDER HEAD/VALVES	6
	CYLINDER/PISTON	7
	DRIVE PULLEY/CLUTCH/ DRIVEN PULLEY	8
	FINAL REDUCTION	9
	ALTERNATOR/STARTER CLUTCH	10
	CRANKCASE/CRANKSHAFT	11
	COOLING SYSTEM	12
	CHASSIS	FRAME COVERS/REAR FRAME
STEERING/FRONT WHEEL/ SUSPENSION		14
REAR WHEEL/BRAKE/SUSPENSION		15
HYDRAULIC BRAKE		16
ELECTRICAL	BATTERY CHARGING SYSTEM	17
	IGNITION SYSTEM	18
	STARTING SYSTEM	19
	SWITCHES	20
	WIRING DIAGRAMS	21
	TECHNICAL FEATURES	22
	TROUBLESHOOTING	23
	INDEX	24

MODEL IDENTIFICATION



BEGINING Frame No. JH2MF020 GK00001
No. JH2MF021 GK00001
(California model)
Engine No. MF02E-5000001



VIN NUMBER

The VIN (Vehicle Identification Number) is attached to the left side of the leg shield.

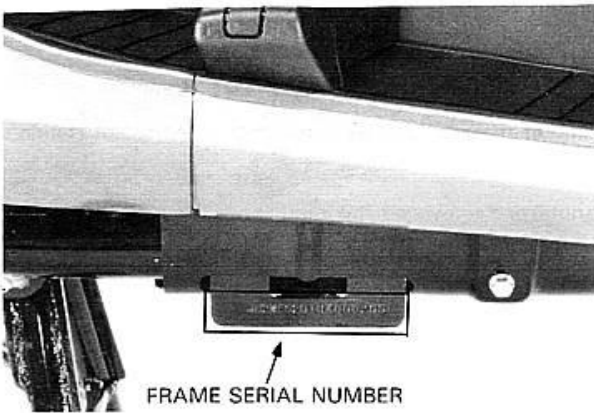

FRAME SERIAL NUMBER

The frame serial number is stamped on the right side of the frame.

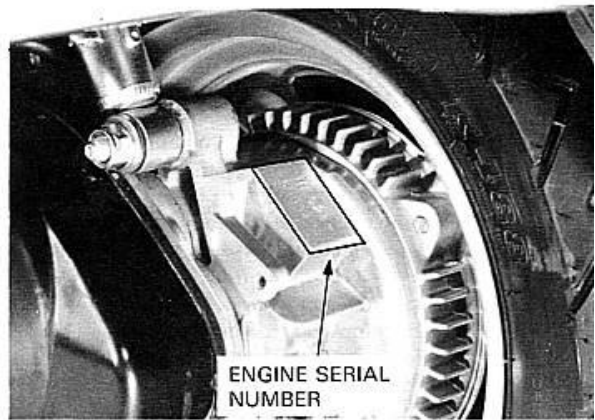

ENGINE SERIAL NUMBER

The engine serial number is stamped on the back of the crankcase near the rear wheel.

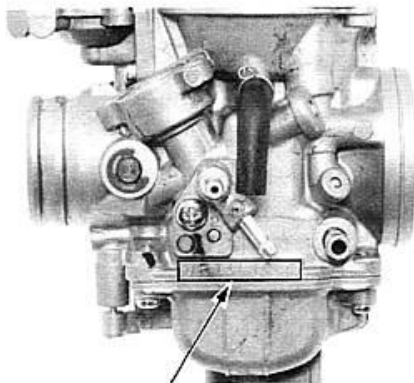

CARBURETOR IDENTIFICATION NUMBER

The carburetor identification number is stamped on the right side of the carburetor.

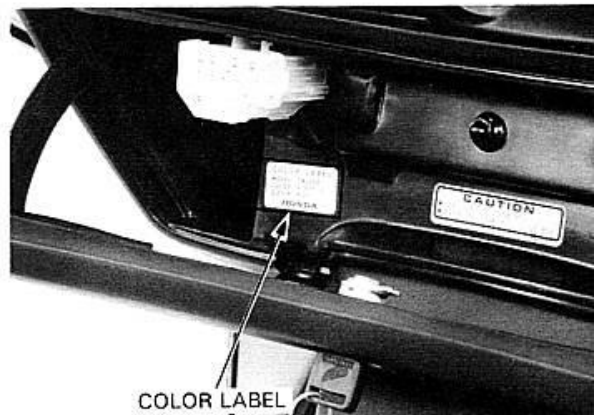

COLOR LABEL

The color label is attached on the glove box.

TORQUE VALUES**ENGINE**

Item	Q'ty	Thread dia. (mm)	Torque values N·m (kg·m, ft·lb)	Remark
Cylinder head cover bolt	5	6	8-12 (0.8-1.2, 6-9)	
Cylinder head cover pan screw	1	5	3.5-5.0 (0.35-0.5, 2.5-3.6)	Apply a locking agent
Cylinder head cap nut	4	8	22-26 (2.2-2.6, 16-19)	
Spark plug	1	—	15-20 (1.5-2.0, 11-15)	
Flywheel nut	1	16	105-115 (10.5-11.5, 76-83)	Apply molybdenum disulfide grease
Starter one-way clutch socket bolt	3	8	28-32 (2.8-3.2, 20-23)	Apply a locking agent
Cam chain adjuster base bolt	2	6	8-12 (0.8-1.2, 6-9)	
Cam chain adjuster sealing bolt	1	8	8-12 (0.8-1.2, 6-9)	
Oil pipe bolt	2	8	8-12 (0.8-1.2, 6-9)	
Water pump impeller	1	12	18-22 (1.8-2.2, 13-16)	Left hand threads
Crankcase bolt	1	7	10-14 (1.0-1.4, 7-10)	
Oil filter screen cap	9	6	8-12 (0.8-1.2, 6-9)	
Drive face nut ('86-'87, '92)	1	30	18-22 (1.8-2.2, 13-16)	
(After '92)	1	14	80-100 (8.0-10.0, 58-72)	Apply oil
Drive face seal cover bolt	3	4	90-100 (9.0-10.0, 65-72)	
Clutch outer nut	1	4	2.5-4.0 (0.25-0.4, 1.8-2.9)	
Moveable driven face nut	1	12	50-60 (5.0-6.0, 36-43)	
Final reduction cover bolt	1	30	70-90 (7.0-9.0, 51-65)	
Transmission oil check bolt	2	6	8-12 (0.8-1.2, 6-9)	
Left crankcase cover bolt	5	8	20-24 (2.0-2.4, 14-17)	
Exhaust pipe stud bolt	1	10	10-15 (1.0-1.5, 7-15)	
Thermostatic sensor	2	6	8-12 (0.8-1.2, 6-9)	Cylinder head side
Rear brake anchor pin nut	2	8	7-11 (0.7-1.1, 5-8)	
Cylinder stud bolt	1	—	8-12 (0.8-1.2, 6-9)	Lock nut
Oil drain plug	1	8	15-20 (1.5-2.0, 11-14)	Crankcase side
Carburetor throttle cable stay screw	4	8	7-11 (0.7-1.2, 5-8)	
	1	12	20-25 (2.0-2.5, 14-18)	
	2	5	4-6 (0.4-0.6, 2.9-4.5)	Apply a locking agent

FRAME

Item	Q'ty	Thread dia. (mm)	Torque values N·m (kg·m, ft·lb)	Remark
Fuel tank drain bolt	1	12	40-60 (4.0-6.0, 29-43)	
Engine hanger stopper rubber bolt	1	8	18-22 (1.8-2.2, 13-16)	
Engine hanger tension arm nut	1	8	24-30 (2.4-3.0, 17-22)	
Engine pivot collar C	1	22	25-35 (2.5-3.5, 18-25)	
Engine hanger mounting bolt	1	12	70-90 (7.0-9.0, 51-65)	
Pivot collar lock nut	1	22	35-50 (3.5-5.0, 25-36)	
Engine hanger bolt	1	10	40-55 (4.0-5.5, 29-40)	
Engine mounting bolt	1	10	55-70 (5.5-7.0, 40-51)	
Steering stem nut	1	24	80-120 (8.0-12.0, 58-87)	
Front/rear wheel hub nut	8	8	28-32 (2.8-3.2, 20-23)	Apply oil
Front axle nut	1	12	60-80 (6.0-8.0, 43-58)	Apply oil
Brake disc bolt	4	8	37-43 (3.7-4.3, 27-31)	Apply a locking agent

Item	Q'ty	Thread dia. (mm)	Torque values N-m (kg-m, ft-lb)	Remark
Front shock absorber:				
upper mounting bolt	2	10	34-45 (3.5-4.5, 25-33)	Apply a locking agent
lower mounting bolt	2	8	0.8-1.2 (0.08-0.12, 0.6-0.9)	
lower lock nut	2	8	15-20 (1.5-2.0, 11-14)	
damper lock nut	2	8	15-25 (1.5-2.5, 11-18)	
Torque link arm:				
front fork side	1	10	35-45 (3.5-4.5, 25-33)	
caliper bracket side	1	8	30-40 (3.0-4.0, 22-29)	
Pivot arm nut	2	10	35-45 (3.5-4.5, 25-33)	
Bearing adjustment nut:	1	26		
initial			30-40 (3.0-4.0, 22-29)	
final			2.5-3.5 (0.25-0.35, 1.8-2.5)	
Handlebar upper holder bolt	4	8	24-30 (2.4-3.0, 17-22)	
Front fork bolt	2	10	50-60 (5.0-6.0, 36-43)	
Speedometer cable set screw	1	5	3.5-5.0 (0.35-0.50, 2.5-3.6)	
Rear axle nut ('86-'87)	1	16	100-120 (10.0-12.0, 72-87)	
(After '91)	1	16	110-130 (11.0-13.0, 80-94)	
Rear brake arm bolt	1	6	8-12 (0.8-1.2, 6-9)	
Rear brake stopper bolt	1	6	10-14 (1.0-1.4, 7-10)	
Rear shock absorber:				
upper mounting bolt	2	8	24-30 (2.4-3.0, 17-22)	Apply a locking agent
left lower mounting nut	1	10	35-45 (3.5-4.5, 25-33)	
left lower stud bolt	1	10	40-50 (4.0-5.0, 29-36)	
right lower mounting bolt	1	8	24-30 (2.4-3.0, 17-22)	
damper lock nut	2	9	20-35 (2.0-3.5, 14-25)	
Exhaust muffler clamp bolt	1	8	20-30 (2.0-3.0, 14-22)	
Exhaust muffler mounting bolt	4	8	32-38 (3.2-3.8, 23-27)	
Bleed valve	1	7	4-7 (0.4-0.7, 2.8-5.1)	
Caliper pin bolt ('86-'87, '92-'93)	1	8	25-30 (2.5-3.0, 18-22)	
Caliper mounting bolt ('86-'87, '92-'93)	1	8	20-25 (2.0-2.5, 14-18)	
Pad pin retainer bolt ('86-'87, '92-'93)	1	6	8-13 (0.8-1.3, 6-9)	Apply a locking agent Apply a locking agent
Caliper pin bolt (After '93)	1	8	25-30 (2.5-3.0, 18-22)	
Caliper bracket pin bolt (After '93)	1	8	10-15 (1.0-1.5, 7-11)	
Pad pin (After '93)	1	10	15-20 (1.5-2.0, 11-14)	
Pad pin plug (After '93)	1	10	2-3 (0.2-0.3, 1.4-2.2)	
Master cylinder holder bolt	2	6	10-14 (1.0-1.4, 7-10)	
Brake oil bolt	2	10	25-35 (2.5-3.5, 18-25)	

Torque specifications listed above are important fasteners. Others should be tightened to standard torque value listed below.

STANDARD TORQUE VALUES

Item	Torque Values N-m (kg-m, ft-lb)	Item	Torque Values N-m (kg-m, ft-lb)
5 mm bolt and nut	4-6 (0.4-0.6, 3-4)	5 mm screw	3-5 (0.3-0.5, 2-4)
6 mm bolt and nut	8-12 (0.8-1.2, 6-9)	6 mm screw	7-11 (0.7-1.1, 5-8)
8 mm bolt and nut	18-25 (1.8-2.5, 13-18)	6 mm flange bolt and nut	10-14 (1.0-1.4, 7-10)
10 mm bolt and nut	30-40 (3.0-4.0, 22-29)	8 mm flange bolt and nut	24-30 (2.4-3.0, 17-22)
12 mm bolt and nut	50-60 (5.0-6.0, 36-43)	10 mm flange bolt and nut	35-45 (3.5-4.5, 25-33)

TOOLS

SPECIAL

Description	Tool number	Alternative	Tool number	Ref. Sec.
Lock nut wrench	07GMA-KS40100	Equivalent commercially available in U.S.A.		8
Ball race driver	07GMD-KS40100	Not available in U.S.A.		14
Flywheel puller	07933-KM10000			10
Clutch spring compressor	07960-KM1000A	(U.S.A. only)		8
Ball race remover attachment	07953-KM10100			14
Spring holder attachment	07967-KM10100			14
Drive pulley holder	07923-KM10000			8
Steering stem socket	07916-3710100			14
Snap ring pliers	07914-3230001			16
Pilot screw wrench	07908-4730000	Equivalent commercially available in U.S.A.		4
Bearing remover set, 12 mm	07936-1660001	Not available		9
(Bearing remover, 12 mm)	(07936-1660100)	in U.S.A.		9
(Remover weight)	(07741-0010201)	Remover weight	07936-3710200	9
Bearing remover set, 20 mm	07936-3710001	Not available		9
(Bearing remover, 20 mm)	(07936-3710600)	in U.S.A.		9
(Remover handle)	(07936-3710100)			9
(Remover weight)	(07741-0010201)	Remover weight	07936-3710200	9
Bearing remover set, 15 mm	07936-KC10000			12
(Bearing remover, 15 mm)	(07936-KC10500)			
(Remover shaft, 15 mm)	(07936-KC10100)			
(Remover head, 15 mm)	(07936-KC10200)			
Remover weight	07741-0010201	Remover weight	07936-3710200	12
Valve guide remover	07942-MA60000			6
Attachment	07945-3330300			14
Mechanical seal driver attachment	07945-4150400	Mechanical seal driver attachment	GN-AH-065-415	12
Attachment, 28 x 30 mm	07946-1870100			12
Driver	07949-3710001			8
Spring holder attachment	07967-VM50100			15
Valve guide reamer, 5.0 mm	07984-MA6000A	Valve guide reamer	07984-MA6000D	6
Vacuum/pressure pump	A937X-041-XXXXX	vacuum pump (U.S.A. only)	ST-AH-260-MC7	4
		pressure pump (U.S.A. only)	ST-AH-255-MC7	4
Steering stem driver	07946-MB00000			14
Digital multimeter	KS-AHM-32-003	U.S.A. only		17, 18
Sanwa electric tester	07308-0020000	Kowa tester	TH-5H	17, 18

GENERAL INFORMATION

COMMON

Description	Tool number	Alternative	Tool number	Ref.sec.
Float level gauge	07401-0010000			4
Lock nut wrench, 30 x 32 mm	07716-0020400	Equivalent commercially available in U.S.A.		14
Extension	07716-0020500			14
Pin spanner	07702-0020001			5
Flywheel holder	07725-0040000	Band strap wrench-commercially available in U.S.A.		10
Valve guide driver	07743-0020000		Not available in U.S.A.	6
Attachment, 32 x 35 mm	07746-0010100			8,14
Attachment, 37 x 40 mm	07746-0010200			9
Attachment, 42 x 47 mm	07746-0010300			9,14,15
Attachment, 52 x 55 mm	07746-0010400			9
Attachment, 24 x 26 mm	07746-0010700			14
Pilot, 10 mm	07746-0040100			14
Pilot, 12 mm	07746-0040200			9,14
Pilot, 17 mm	07746-0040400			15
Pilot, 20 mm	07746-0040500			9
Pilot, 25 mm	07746-0040600			9
Pilot, 22 mm	07746-0041000			8,9
Bearing remover shaft	07746-0050100	Equivalent commercially available in U.S.A.		14
Bearing remover head, 10 mm	07746-0050200			14
Bearing remover head, 12 mm	07746-0050300			14
Driver	07749-0010000	Driver	07949-3710001	8,9,12
Valve spring compressor	07757-0010000			14,15
Shock absorber compressor	07959-3290001			5
Driver 22 mm I.D.	07746-0020100			14,15
				9

CABLE AND HARNESS ROUTING

Note the following when routing cables and wire harnesses.

- A loose wire, harness or cable can be a safety hazard. After clamping, check each wire to be sure it is secure.
- Do not squeeze wires against the weld or end of its clamp.
- Secure wires and wire harnesses to the frame with their respective wire bands at the designated locations. Tighten the bands so that only the insulated surfaces contact the wires or wire harnesses.
- Route harnesses so they are not pulled taut or have excessive slack.
- Protect wires and harnesses with electrical tape or tube if they contact a sharp edge or corner. Clean the attaching surface thoroughly before applying tape.
- Do not use wires or harnesses with broken insulation. Repair by wrapping them with a protective tape or replace them.
- Route wire harness to avoid sharp edges or corners. Also avoid the projected ends of bolts and screws.
- Keep wire harnesses away from the exhaust pipes and other hot parts.
- Be sure grommets are seated in their grooves properly.
- After clamping, check each harness to be certain that it is not interfering with any moving or sliding parts.
- After routing, check that the wire harnesses are not twisted or kinked.
- Wire harnesses routed along the handlebars should not be pulled taut, have excessive slack, be pinched, or interfere with adjacent or surrounding parts in all steering positions.
- Do not bend or twist control cables. Damaged control cables will not operate smoothly and may stick or bind.

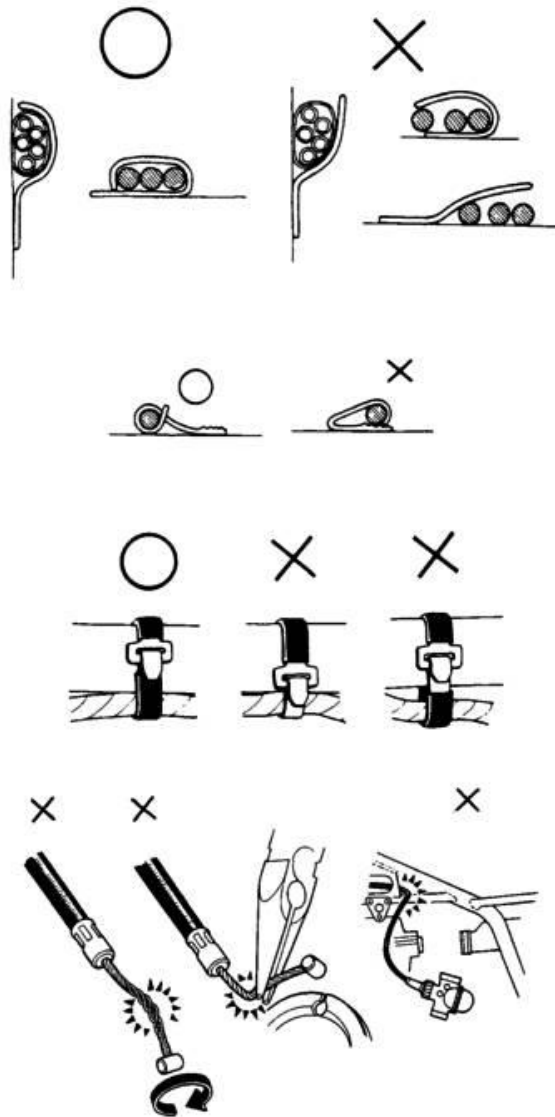

O: CORRECT
X: INCORRECT

GENERAL INFORMATION

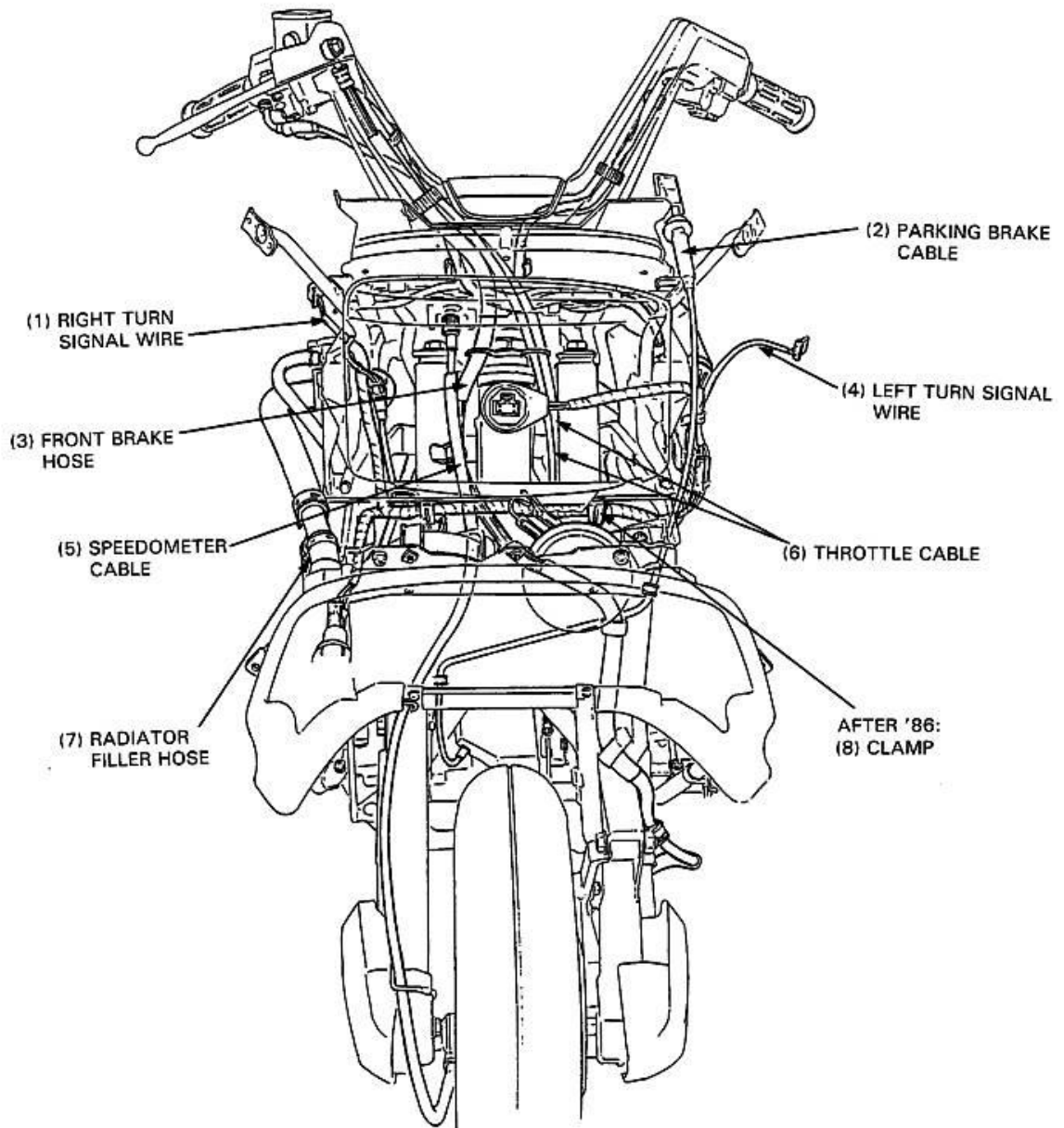

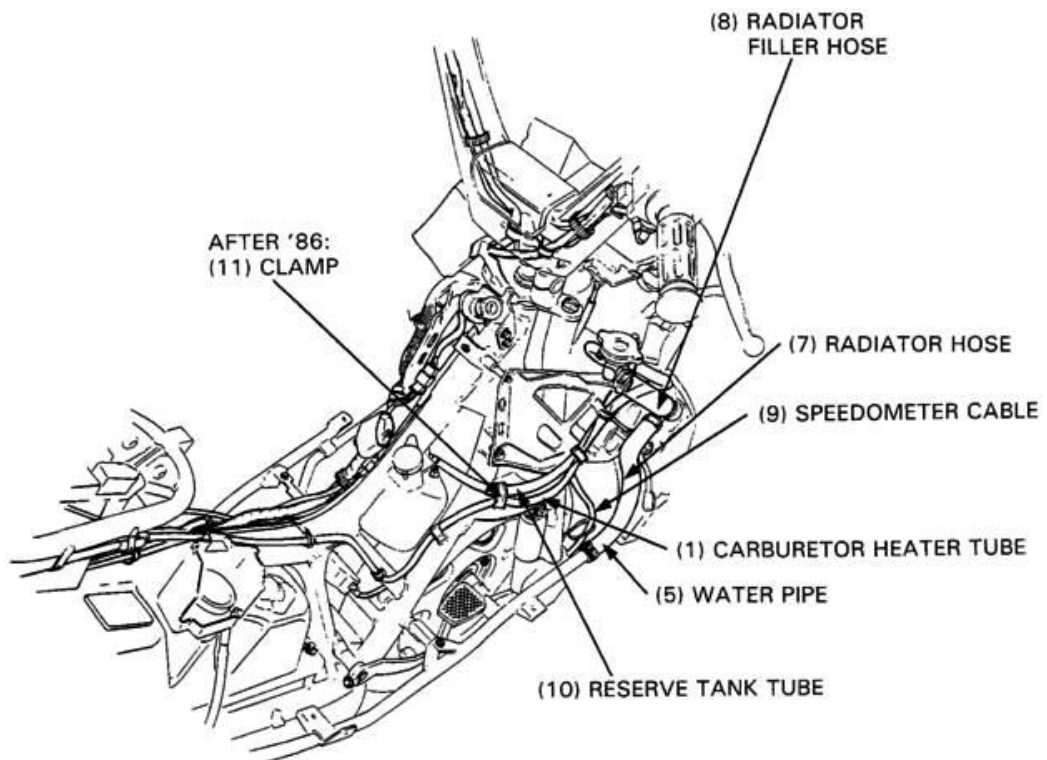
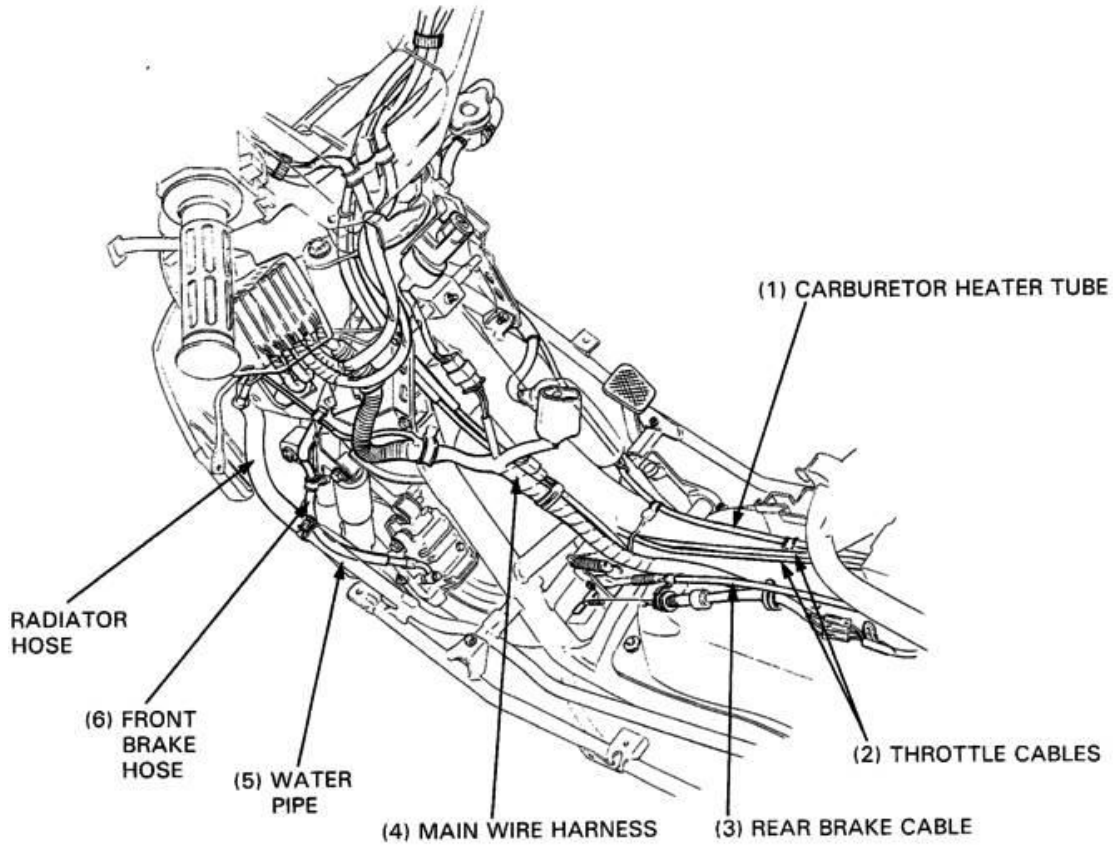

GENERAL INFORMATION

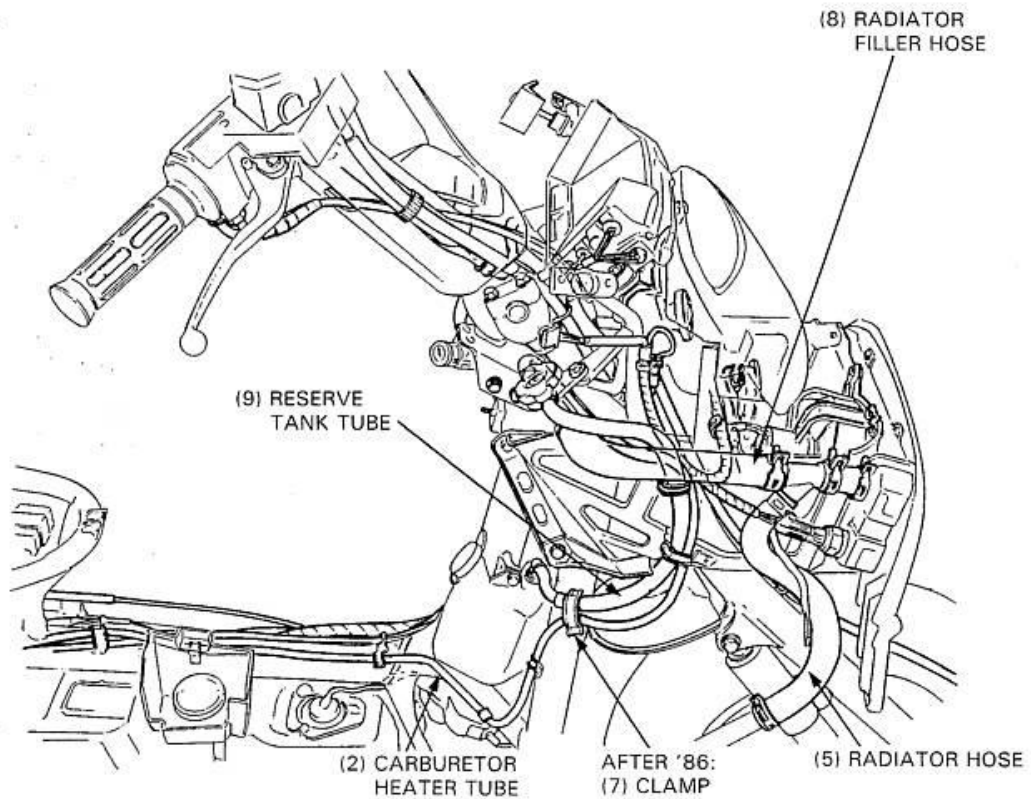
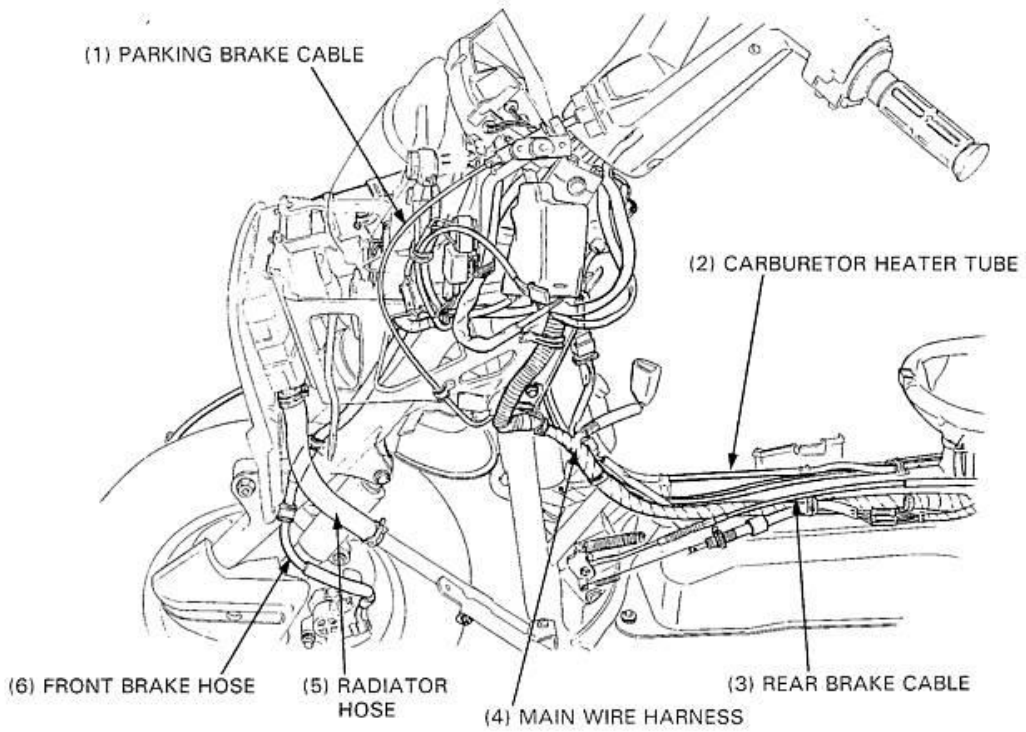

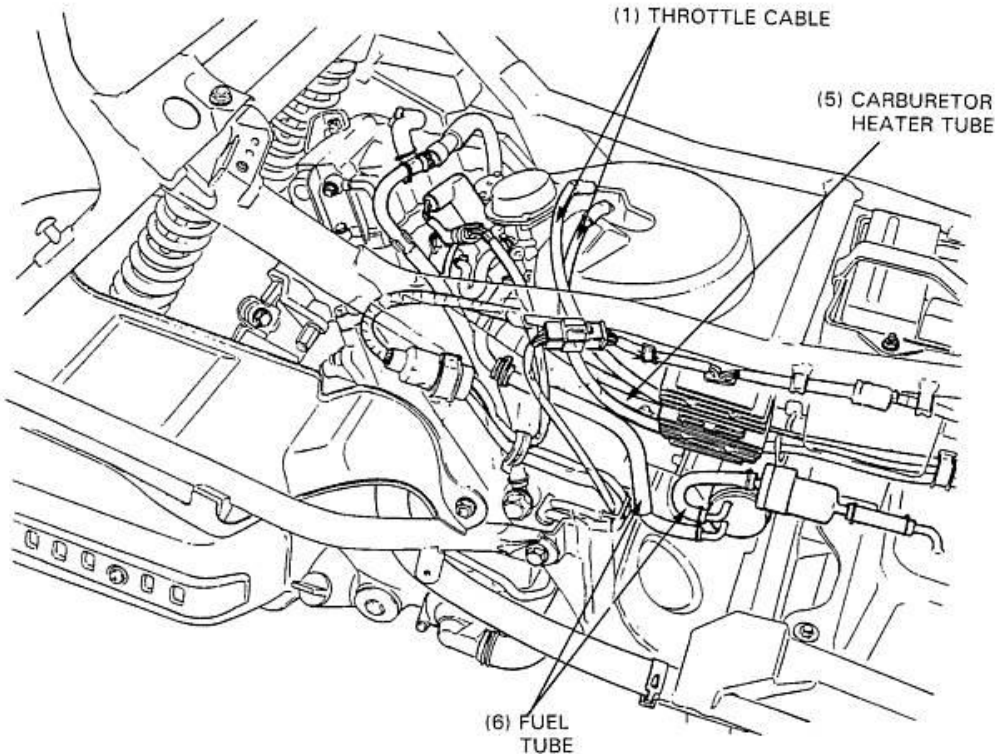
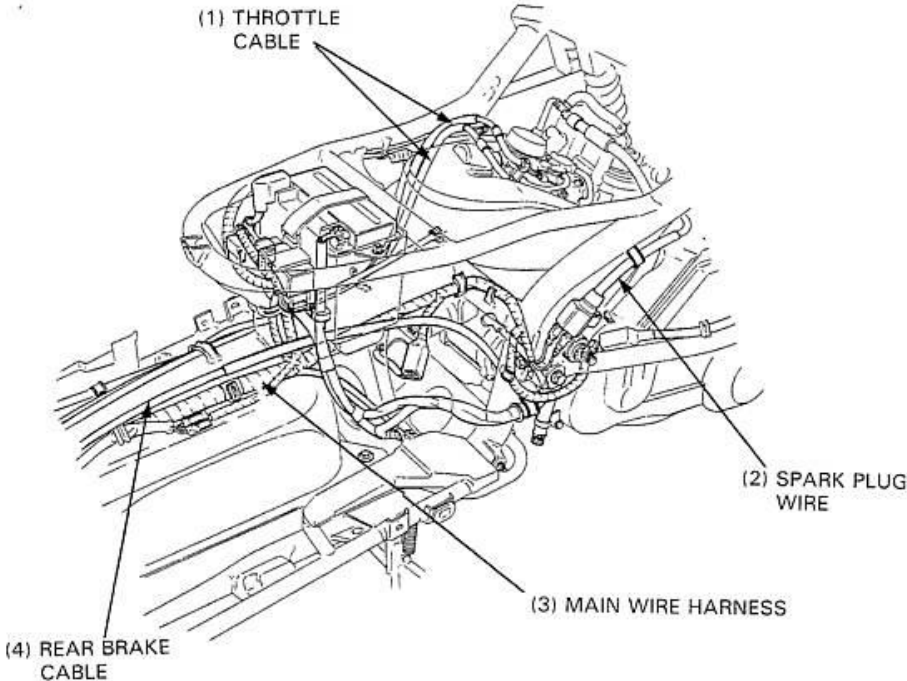

GENERAL INFORMATION

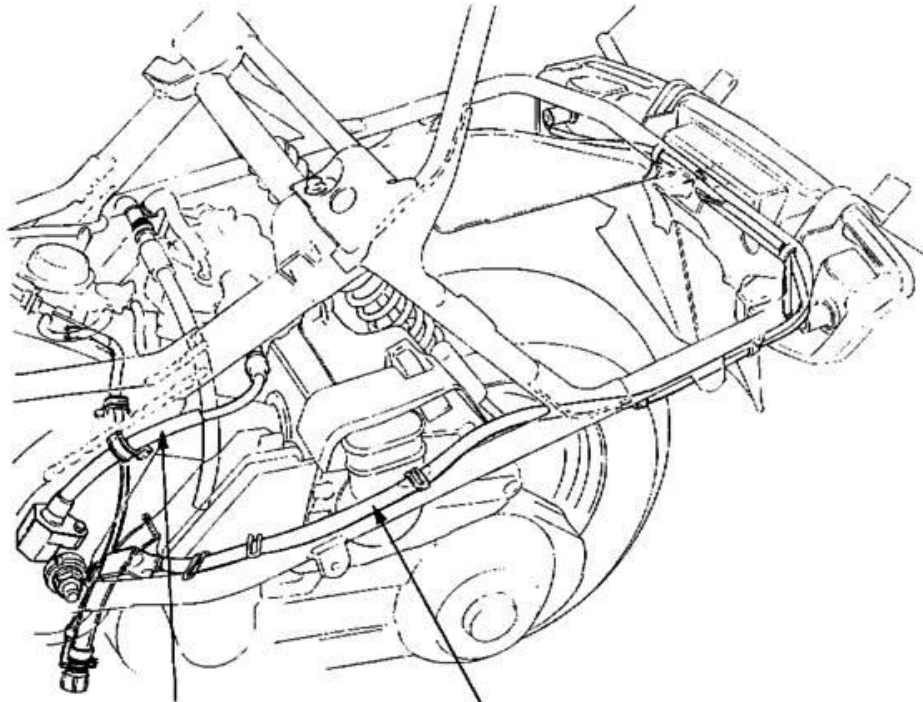

(1) SPARK PLUG WIRE (2) REAR FRAME WIRE HARNESS

After '91:

(3) SIDE STAND SWITCH CONNECTORS

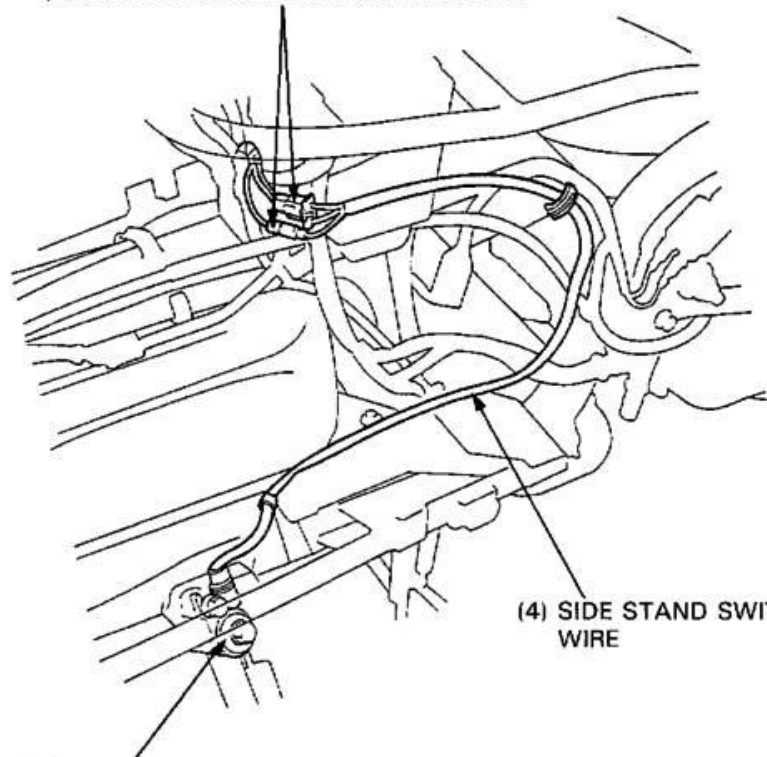

(4) SIDE STAND SWITCH WIRE

LUBRICATION

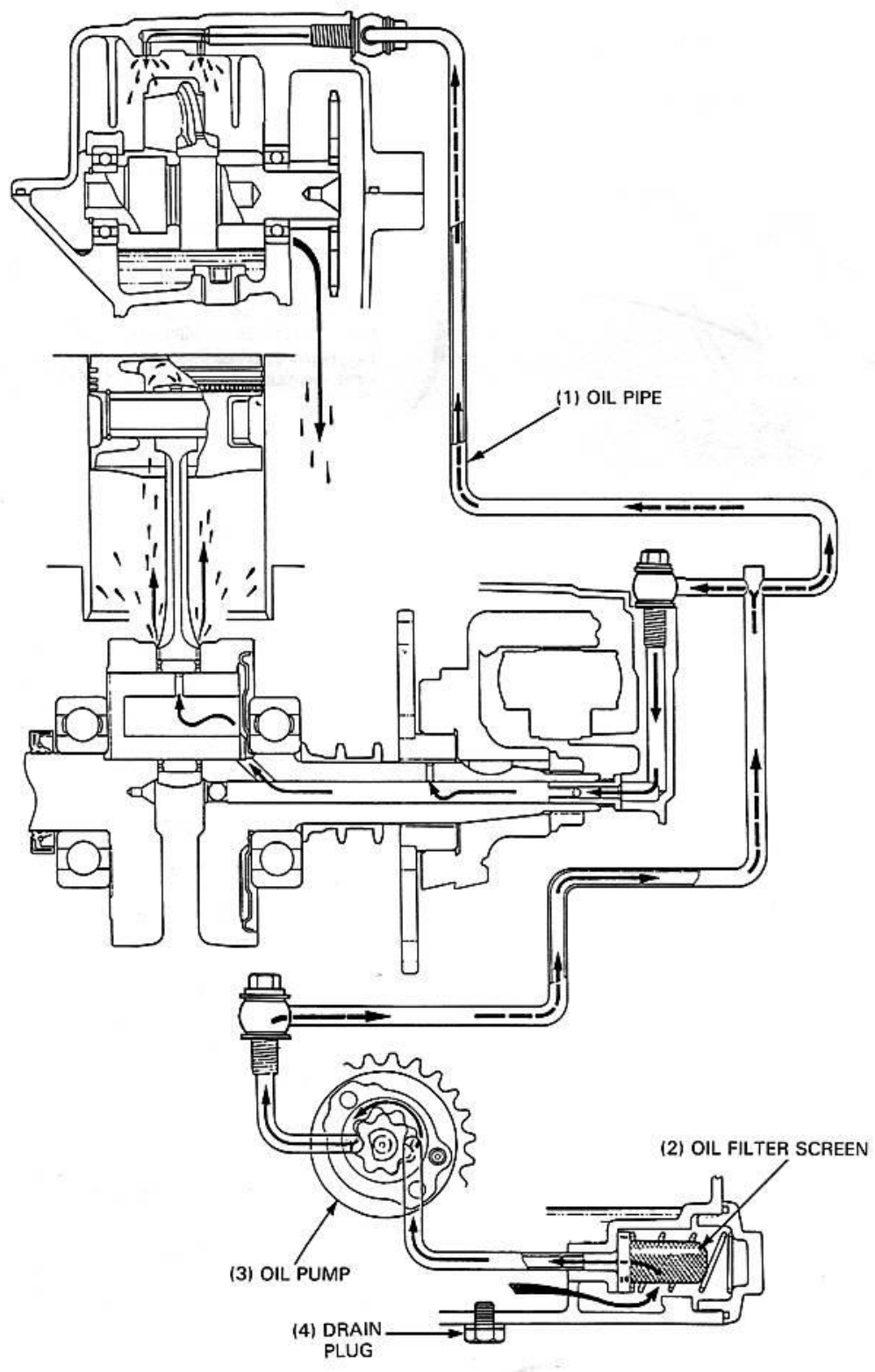

2. LUBRICATION

SERVICE INFORMATION	2-1	OIL PUMP INSPECTION	2-4
TROUBLESHOOTING	2-1	OIL PUMP ASSEMBLY	2-4
ENGINE OIL	2-2	OIL PUMP INSTALLATION	2-5
ENGINE OIL FILTER SCREEN CLEANING	2-2	TRANSMISSION OIL	2-6
OIL PUMP REMOVAL	2-3	LUBRICATION POINTS	2-7
OIL PUMP DISASSEMBLY	2-3		

SERVICE INFORMATION

GENERAL

- This section covers maintenance of the oil pump and engine oil. This service can be done with the engine installed in the frame.
- When removing and installing the oil pump use care not to allow dust or dirt to enter the engine and oil line.
- When the oil pump clearances are not within specification, replace the oil pump as an assembly.

SPECIFICATIONS

Engine oil capacity 1.0 liter (1.06 US qt, 0.88 Imp qt) at disassembly
0.8 liter (0.85 US qt, 0.70 Imp qt) at change

Transmission oil capacity 0.2 liter (0.21 US qt, 0.18 Imp qt) at disassembly
0.15 liter (0.16 US qt, 0.13 Imp qt) at change

Recommended oil Use Honda 4-Stroke Oil or equivalent.
API Service Classification: SF or SG
VISCOSITY: SAE 10W-40

Other viscosities shown in the chart may be used when the average temperature in your riding area is within the indicated range.

OIL VISCOSITIES

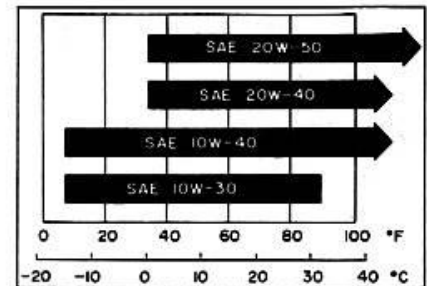

ITEM		STANDARD mm (in)	SERVICE LIMIT mm (in)
Oil pump	Rotor tip clearance	0.15 (0.006)	0.20 (0.008)
	Body clearance	0.15-0.20 (0.006-0.008)	0.25 (0.010)
	Rotor end clearance	0.04-0.09 (0.002-0.004)	0.12 (0.005)

TORQUE VALUES

Oil drain plug	20-25 N·m (2.0-2.5 kg-m, 15-18 ft-lb)
Oil filter screen cap	18-22 N·m (1.8-2.2 kg-m, 13-16 ft-lb)
Transmission oil check bolt	10-15 N·m (1.0-1.5 kg-m, 7-11 ft-lb)
Transmission oil drain bolt	8-12 N·m (0.8-1.2 kg-m, 6-9 ft-lb)

TROUBLESHOOTING

Oil level too low

- External oil leaks
- Worn valve guide or seal
- Worn piston rings

Low oil pressure

- Oil level too low
- Clogged oil filter, oil passage, and or oil pipe
- Faulty oil pump

Oil contamination

- Oil not changed often enough
- Head gasket faulty
- Worn piston rings

LUBRICATION

ENGINE OIL

OIL LEVEL

Warm up the engine.
Stop the engine and support the scooter upright on level ground.
Check the oil level with the filler cap/dipstick.
Do not screw in the dipstick when making this check.
If the level is near the lower level, fill to the upper level with the recommended engine oil.

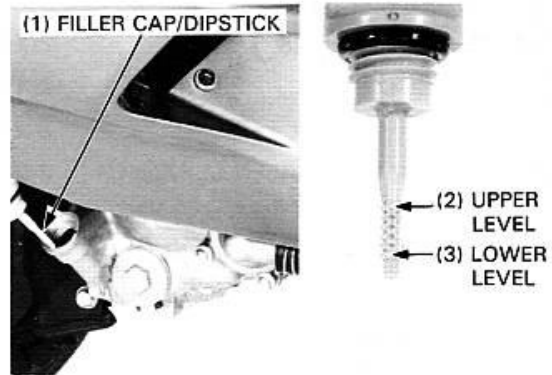

OIL CHANGE

NOTE This!

NOTE

- Drain the oil from the crankcase while the engine is warm.
This ensures complete and rapid draining.

Place the oil pan under the engine.
Remove the oil filler cap/dipstick and oil drain plug and drain the engine oil
Remove the oil filter screen cap, spring and filter screen, and clean the filter screen
After the oil has been completely drained, be sure the O-ring on the filter screen cap is in good condition and install the filter screen with the closed end facing out
Install the spring and cap

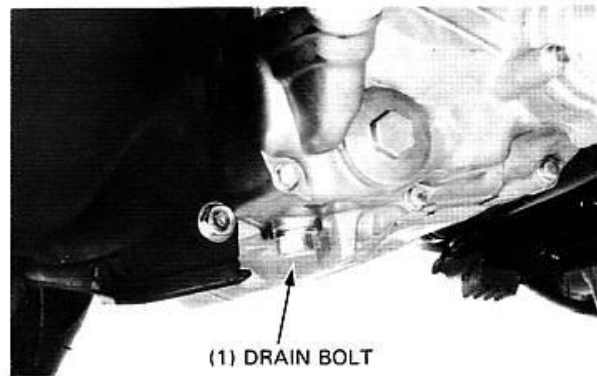

TORQUE: 18–22 N·m (1.8–2.2 kg·m, 13–16 ft·lb)

Make sure that the sealing washer is in good condition, install the drain plug and tighten it.

TORQUE: 20–25 N·m (2.0–2.5 kg·m, 15–18 ft·lb)

Fill the engine with recommended engine oil through the oil filler hole.

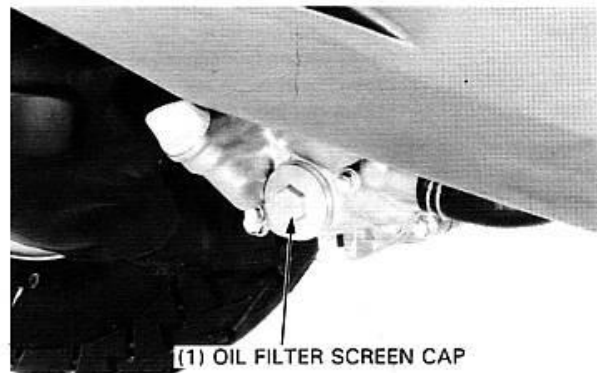

ENGINE OIL CAPACITY:

0.8 liter (0.85 US qt, 0.7 Imp qt) at change

Reinstall the oil filler cap/dipstick and start the engine and let it idle for a few minutes.
Recheck the oil level.
Check that there are no oil leaks.

ENGINE OIL FILTER SCREEN CLEANING

Drain the engine oil.
Remove the filter screen cap, spring and filter screen.
Clean the oil filter screen.
Install the oil filter screen with its closed end facing out and the spring as shown.
Make sure that the O-ring on the filter screen cap is in good condition; install and tighten the oil filter screen cap.

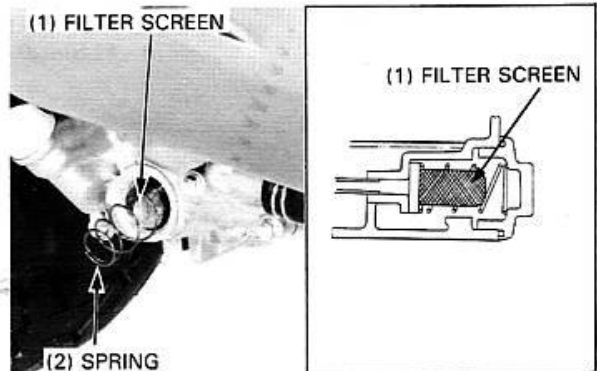

TORQUE: 18–22 N·m (1.8–2.2 kg·m, 13–16 ft·lb)

Pour the recommended engine oil (page 2-1) through the oil filler cap.

NOTE - pages 2-3 to 2-5 cover disassembly of the oil pump

These pages will NOT be uploaded unless someone requests them since it seems unlikely that anyone other than a professional mechanic

will be doing this class of work, or have the professional tools required.

LUBRICATION

TRANSMISSION OIL

OIL LEVEL CHECK

Place the scooter on its center stand on level ground.
Stop the engine and remove the transmission oil check bolt.
The oil level should be at the oil check bolt hole threads.
If the level is low, fill the transmission with the recommended oil (page 2-1).
Check that the sealing washer is in good condition, and replace if necessary.
Install the oil check bolt.

TORQUE: 10–15 N·m (1.0–1.5 kg·m, 7–11 ft·lb)

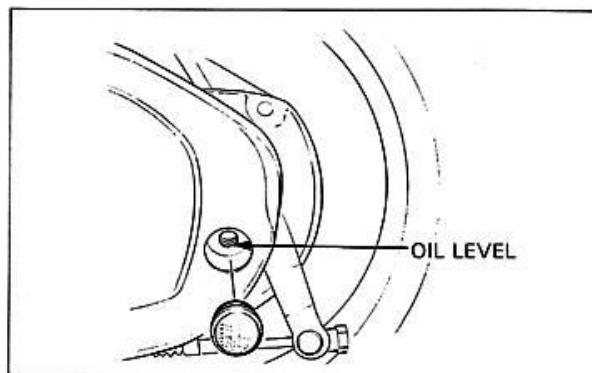

OIL CHANGE

Remove the oil check bolt.
Remove the oil drain bolt and drain the oil thoroughly into a suitable container.
Make sure that the drain bolt sealing washer is in good condition.
Reinstall the drain bolt.

TORQUE: 8–12 N·m (0.8–1.2 kg·m, 6–9 ft·lb)

Fill the transmission with the recommended oil (page 2-1) through the oil check bolt hole up to the bolt hole threads.

CAPACITY: 0.15 liter (0.16 US qt, 0.13 Imp qt)

Make sure that the oil check bolt sealing washer is in good condition, and reinstall the oil check bolt.
Start the engine and test ride for 2–3 minutes.
Stop the engine and make sure that the oil level is correct.
Make sure that there are no oil leaks.

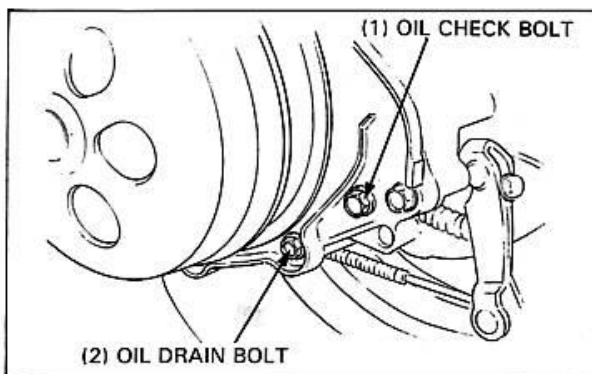

LUBRICATION POINTS

Use general purpose grease when not specified here.
Apply oil or grease to sliding surfaces not shown here.

CONTROL CABLES

Periodically, disconnect the throttle and brake cables at their upper ends. Thoroughly lubricate the cables and their pivot points with a commercially available cable lubricant or a light weight oil.



3. MAINTENANCE

SERVICE INFORMATION	3-1	DRIVE BELT	3-9
MAINTENANCE SCHEDULE	3-2	BELT CASE AIR CLEANER	3-10
FUEL LINES	3-4	BRAKE FLUID	3-10
THROTTLE OPERATION	3-4	BRAKE SHOE/PAD WEAR	3-11
AIR CLEANER	3-5	BRAKE SYSTEM	3-11
CRANKCASE BREATHER	3-5	BRAKE LIGHT SWITCH/ STARTER LIMITER SWITCH	3-12
SPARK PLUG	3-5	BRAKE LOCK LEVER	3-12
VALVE CLEARANCE	3-6	HEADLIGHT AIM	3-12
CARBURETOR-IDLE SPEED	3-7	CLUTCH SHOE WEAR	3-13
RADIATOR COOLANT	3-7	SIDE STAND	3-13
COOLING SYSTEM HOSE AND CONNECTIONS	3-7	SUSPENSION	3-14
IGNITION TIMING	3-7	NUTS, BOLTS, FASTENERS	3-14
CYLINDER COMPRESSION	3-8	WHEELS	3-15
EVAPORATIVE EMISSION CONTROL SYSTEM (California type only)	3-8	STEERING HEAD BEARINGS	3-15

SERVICE INFORMATION

GENERAL

Engine oil see page 2-2
 Oil filter screen see page 2-2
 Transmission oil see page 2-6

SPECIFICATIONS

Throttle grip free play 2–6 mm (1/8–1/4 in)

Spark plug:

Standard		For cold climate (below 5°C, 41°F)		For extended high speed riding	
NGK	NIPPONDENSO	NGK	NIPPONDENSO	NGK	NIPPONDENSO
DPR6EA-9	X20EPR-U9	DPR5EA-9	X16EPR-U9	DPR7EA-9	X22EPR-U9

Spark plug gap 0.8–0.9 mm (0.031–0.035 in)
 Valve clearance 0.08–0.12 mm (0.003–0.005 in)
 Idle speed 1,500±100 rpm
 Ignition timing 12° BTDC ("F" mark) at 1,500±100 rpm
 27° BTDC (Advance mark) at 6,700±100 rpm
 Compression pressure 1,500±200 kPa (15 ± 2 kg/cm², 213 ± 28 psi) at 600 rpm
 Rear brake pedal free play 20–30 mm (3/4–1 1/8 in)
 Tire pressure

	Front	Rear
Up to 90 kg (200 lb) load	175 kPa (1.75 kg/cm ² , 24 psi)	200 kPa (2.00 kg/cm ² , 28 psi)
Up to vehicle capacity load	175 kPa (1.75 kg/cm ² , 24 psi)	225 kPa (2.25 kg/cm ² , 32 psi)

MAINTENANCE

MAINTENANCE SCHEDULE

'86:

Perform the Pre-ride Inspection in the Owner's Manual at each scheduled maintenance period.

I: INSPECT AND CLEAN, ADJUST LUBRICATE, OR REPLACE IF NECESSARY.

C: CLEAN

R: REPLACE

ITEM	FREQUENCY	WHICHEVER COMES FIRST		ODOMETER READING (NOTE 4)							Refer to page
		EVERY	→	600 mi (1,000 km)	4,000 mi (6,400 km)	8,000 mi (12,800 km)	12,000 mi (19,200 km)	16,000 mi (25,600 km)	20,000 mi (32,000 km)	24,000 mi (38,400 km)	
EMISSION RELATED ITEMS	* FUEL LINES				I		I		I	3-4	
	* THROTTLE OPERATION				I		I		I	3-4	
	AIR CLEANER	NOTE 1				R		R		3-5	
	CRANKCASE BREATHER	NOTE 2		C	C	C	C	C	C	3-5	
	SPARK PLUG			R	R	R	R	R	R	3-5	
	* VALVE CLEARANCE		I		I		I		I	3-6	
	ENGINE OIL		R	Replace every 1,250 mi (2,000 km)						2-2	
	* ENGINE OIL STRAINER SCREEN				C		C		C	2-2	
	* CARBURETOR-IDLE SPEED		I	I	I	I	I	I	I	3-7	
	RADIATOR COOLANT	2 YEARS *R			I		I		*R	3-7	
	* COOLING SYSTEM HOSE & CONNECTIONS				I		I		I	3-7	
* EVAPORATIVE EMISSION CONTROL SYSTEM	NOTE 3				I			I	3-8		
NON-EMISSION RELATED ITEMS	** DRIVE BELT				I	R	I	I	R	3-9	
	BELT CASE AIR CLEANER			C	C	C	C	C	C	3-9	
	* FINAL DRIVE OIL	2 YEARS *R								2-7	
	BRAKE FLUID	2 YEARS *R		I	I	*R	I	I	R	3-10	
	BRAKE SHOE/PAD WEAR			I	I	I	I	I	I	3-11	
	BRAKE SYSTEM		I		I		I		I	3-11	
	* BRAKE LIGHT SWITCH				I		I		I	3-12	
	STARTER LIMITER SWITCH			I	I	I	I	I	I	3-12	
	* BRAKE LOCK LEVER			I	I	I	I	I	I	3-12	
	* HEADLIGHT AIM				I		I		I	3-12	
	** CLUTCH SHOE WEAR			I	I	I	I	I	I	3-13	
	SIDE STAND				I		I		I	3-13	
	* SUSPENSION				I		I		I	3-14	
	* NUTS, BOLTS, FASTENERS		I		I		I		I	3-14	
** WHEELS				I		I		I	3-15		
** STEERING HEAD BEARINGS		I		I		I		I	3-15		

* SHOULD BE SERVICED BY AN AUTHORIZED HONDA SCOOTER DEALER, UNLESS THE OWNER HAS PROPER TOOLS AND SERVICE DATA AND IS MECHANICALLY QUALIFIED.

** IN THE INTEREST OF SAFETY, WE RECOMMEND THESE ITEMS BE SERVICED ONLY BY AN AUTHORIZED HONDA SCOOTER DEALER.

NOTE (1) Service more frequently when riding in dusty areas.

(2) Service more frequently when riding in rain or at full throttle.

(3) California type only.

(4) For higher odometer readings, repeat at the frequency interval established here.

MAINTENANCE

FUEL LINES

Remove the seat (page 13-2).

Check the fuel lines and replace any parts which show signs of deterioration, damage or leakage.

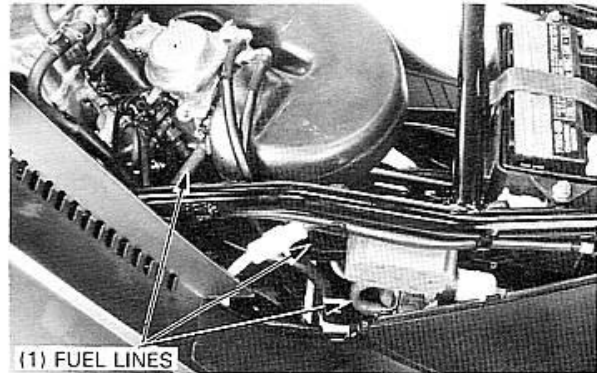

THROTTLE OPERATION

Check for smooth throttle grip full opening and full automatic closing in all steering positions.

Check the throttle cable and replace it, if it is deteriorated, or damaged.

Lubricate the throttle cable (page 2-7), if throttle operation is not smooth.

Measure the throttle grip free play at the throttle grip flange.

FREE PLAY: 2–6 mm (1/8–1/4 in)

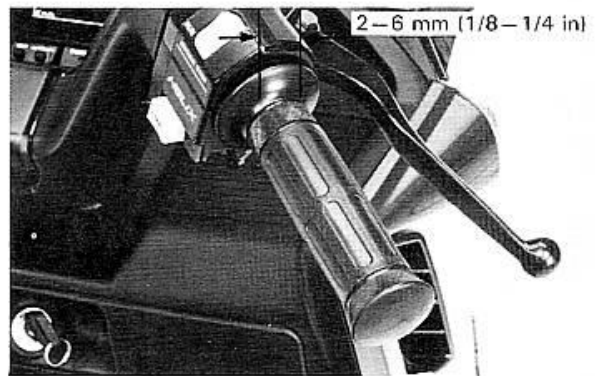

Adjustment can be made at either end of the throttle cable.

Minor adjustments are made with the upper adjuster.

Slide the rubber cover off and adjust by loosening the lock nut and turning the adjuster.

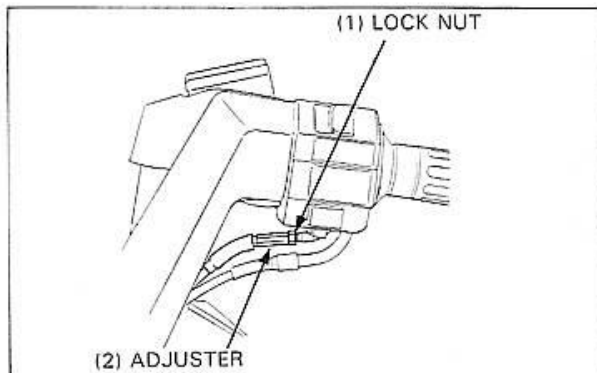

Major adjustments are made with the lower adjusting nuts.

Remove the seat (page 13-2).

Adjust the throttle cable by loosening the lock nuts and turning the adjusting nuts.

Tighten the lock nuts and recheck the throttle grip free play and throttle operation.

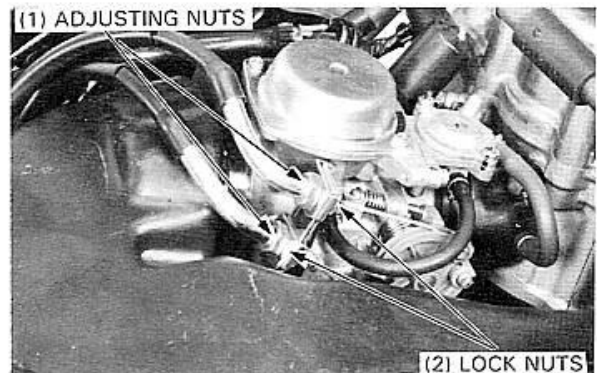

AIR CLEANER

Remove the left rear cover (page 13-2).
Remove the five air cleaner housing cover screws, clip and the cover.

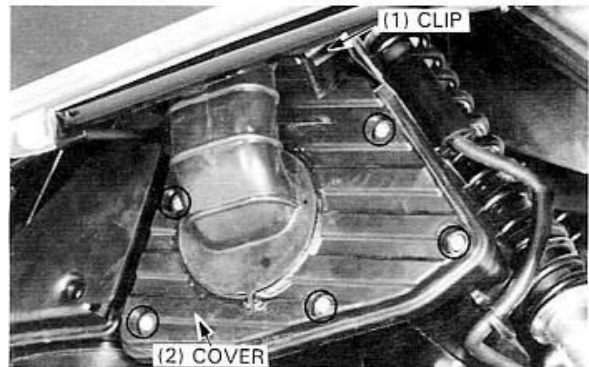

Remove the screw and discard the element in accordance with the maintenance schedule (page 3-2 or 3-3).
Also replace the element any time it becomes excessively dirty or damaged.

NOTE

- The air cleaner element is of a viscous type paper element. Do not try to clean it.

Install a new element, screw, air cleaner housing cover and install the five screws and clip.
Install the left rear cover.

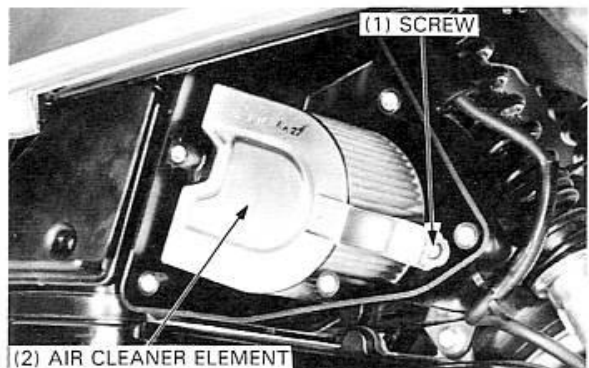

CRANKCASE BREATHER

Remove the plug from the breather tube to drain any residue into a suitable container.

NOTE

- Service more frequently when ridden in rain or at full throttle or if the deposit level can be seen in the transparent section of the drain tube.

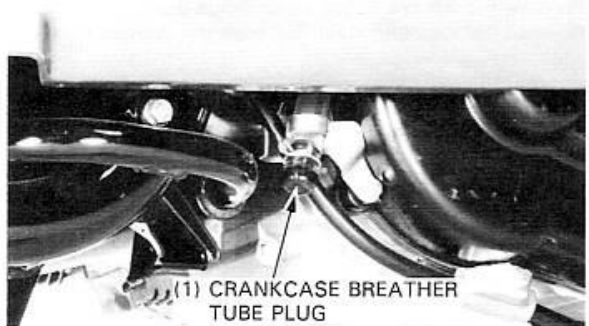

SPARK PLUG

Remove the seat (page 13-2).
Disconnect the spark plug cap.
Clean any dirt from around the spark plug base.
Remove and discard the spark plug.
Measure the new spark plug gap using a wire-type feeler gauge.

SPARK PLUG GAP: 0.8–0.9 mm (0.03–0.04 in)

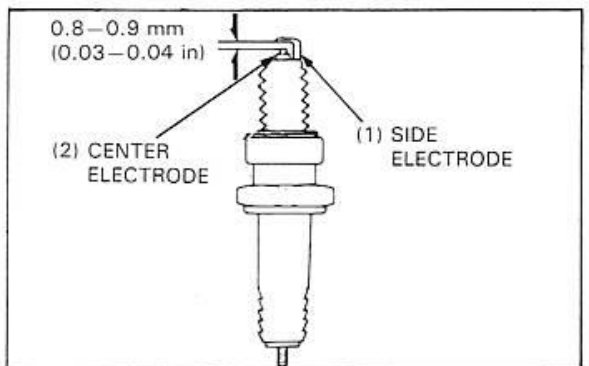

MAINTENANCE

Adjust by bending the side electrode carefully.
 With the plug washer attached, thread the spark plug in by hand to prevent cross threading.
 Tighten the spark plug.

TORQUE: 15–20 N·m (1.5–20. kg·m, 11–15 ft·lb)

Then connect the spark plug cap.

NOTE

- Be careful not to over-tighten the spark plug.

SPECIFIED SPARK PLUGS:

	NGK	NIPPONDENSO
Standard	DPR6EA-9	X20EPR-U9
For cold climate (below 5°C, 41°F)	DPR5EA-9	X16EPR-U9
For extended high speed riding	DPR7EA-9	X22EPR-U9

VALVE CLEARANCE

NOTE

- Inspect and adjust valve clearance while the engine is cold (below 35°C/95°F).

Remove the seat and left rear cover (page 13-2).
 Remove the left crankcase cover (page 8-3).
 Remove the inspection hole cap from the cylinder head cover.

Rotate the drive pulley counterclockwise and align the punch mark on the camshaft with the index mark on the cylinder head cover to bring the piston to TDC (Top Dead Center) on the compression stroke.

Loosen the valve adjuster lock bolts, which are located on the left side of the cylinder head cover.

Move the intake and exhaust valve adjusters outward (away from each other) until resistance is felt. Then move them inward (toward each other), the equivalent distance of 1/2 marked graduation.

NOTE

- 1/2 graduation on the adjusters equals 0.10 mm (0.004 in), which is the specified valve clearance.

Tighten the valve adjuster lock bolts.
 Install the inspection hole cap, left crankcase cover, left rear cover and seat.

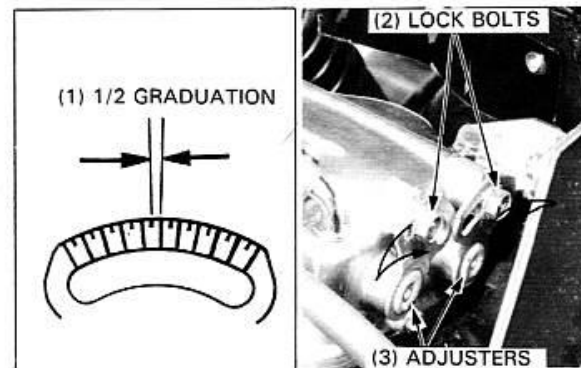
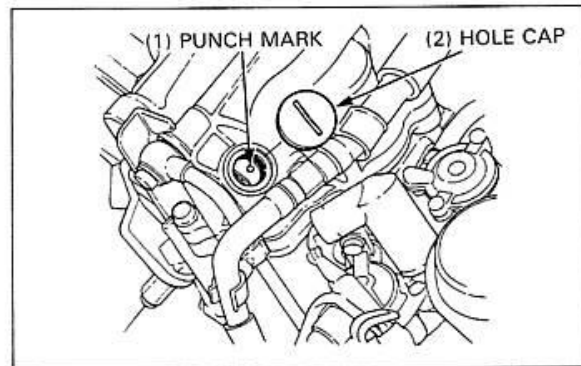
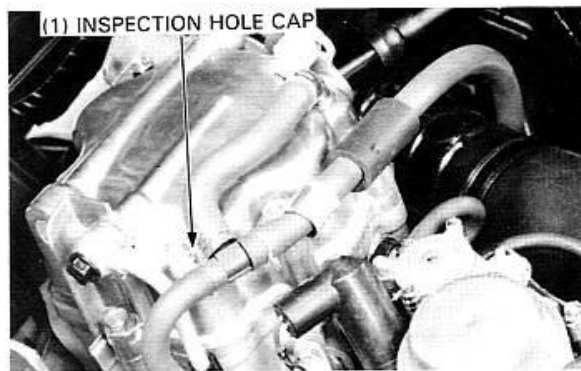

CARBURETOR-IDLE SPEED

NOTE

- Inspect and adjust idle speed after all other engine adjustments are within specifications.
- The engine must be warm for accurate idle inspection and adjustment. Ten minutes of stop and go riding is sufficient.

Remove the seat (page 13-2).
Place the scooter on its center stand and warm up the engine.
Connect a tachometer.
Turn the throttle stop screw to obtain the specified idle speed.

IDLE SPEED: 1,500 ± 100 rpm

RADIATOR COOLANT

Place the scooter on its center stand.
Remove the reserve tank cover.
Check the coolant level in the reserve tank while the engine is at the normal operating temperature.
If the coolant level is low, remove the reserve tank cap and add coolant until it reaches the UPPER level mark.

WARNING

- *Do not remove the radiator cap when the engine is hot. The coolant is under pressure and severe scalding could result.*

If the reserve tank is empty, or if coolant loss is excessive, check for leaks.

COOLING SYSTEM HOSE AND CONNECTIONS

Inspect the hoses for cracks or deterioration, and replace if necessary.
Secure all hose clamps.

Remove the front upper cover (page 13-7).
Check the radiator air passages for clogging or damage.
Straighten bent fins.
Remove any obstructions with compressed air or low water pressure.
Replace the radiator if the air flow is restricted over more than 20% of the radiating surface.

IGNITION TIMING

NOTE

- The Capacitive Discharge Ignition system is factory pre-set and cannot be adjusted. Ignition timing inspection procedures are given to inspect the function of the ignition control module (ICM) components.

Remove the seat and right rear cover (page 13-2).
Remove the timing hole cap.

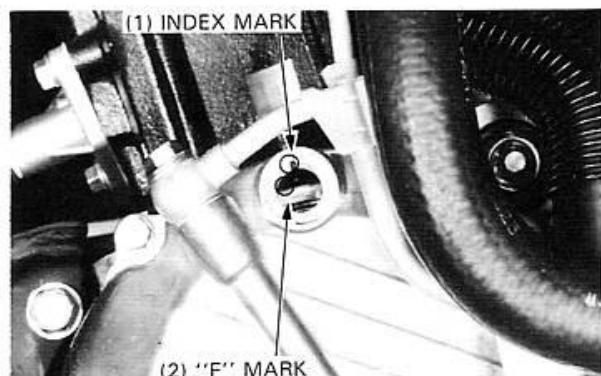
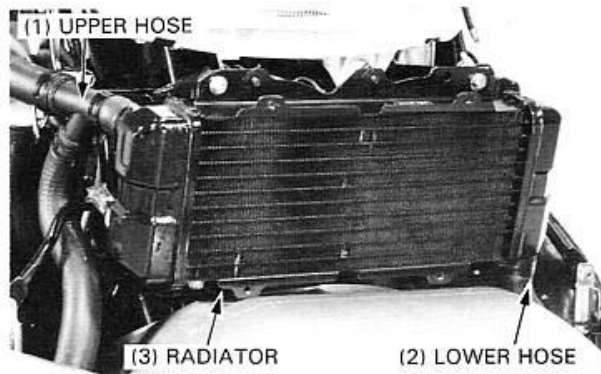
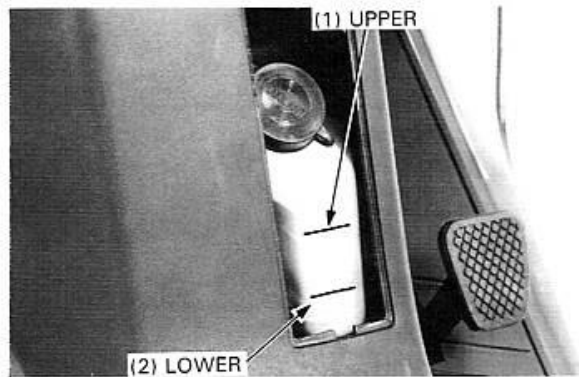

MAINTENANCE

Connect a tachometer and timing light to the engine.
Start the engine.

The ignition timing at idle is correct if the index mark on the right crankcase cover aligns with the "F" mark on the flywheel at idle of 1,500 rpm.

To check the advance, raise the engine speed to 6,700 rpm; the index mark should be between the advance marks.

If the ignition timing is incorrect, check the ignition control module (ICM), ignition pulse generator, flywheel and wiring, and replace or repair faulty parts.

Refer to Section 18 ignition system.

CYLINDER COMPRESSION

Warm up the engine.

Stop the engine, remove the seat (page 13-2), disconnect the spark plug cap and remove the spark plug.

Install the compression gauge.

Open the throttle fully and crank the engine.

NOTE

- Crank the engine until the gauge reading stops rising. The maximum reading is usually reached within 4–7 seconds.

COMPRESSION PRESSURE:

1,500 ± 200 kPa (15 ± 2 kg/cm², 213 ± 28 psi) at 600 rpm

If compression is low, check for the following:

- Improper valve clearance
- Leaky valves
- Leaking cylinder head gasket
- Worn piston/ring/cylinder

If compression is high, it indicates that carbon deposits have accumulated on the combustion chamber and/or the piston crown.



EVAPORATIVE EMISSION CONTROL SYSTEM (California type only)

Check the air vent and vacuum tubes between the carburetor, evaporative emission (EVAP) purge control valve, air cleaner and evaporative emission (EVAP) canister to ensure they are securely fastened. Also check the tubes for clogging due to bending or twisting.

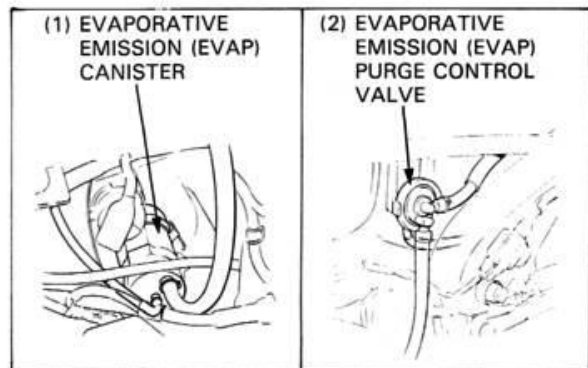

Check the system hoses for damage, deterioration, clogging or loose connections.
 Check the EVAP canister for cracks or damage.
 Refer to the vacuum hose routing diagram label on the left side of battery box for hose connections.

NOTE

- Replace any worn or damaged parts.

'86-'87, '92-'93:

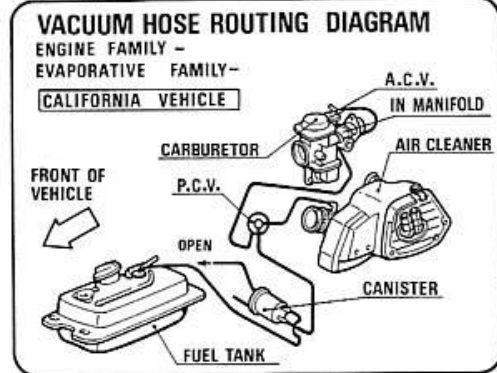

After '93:

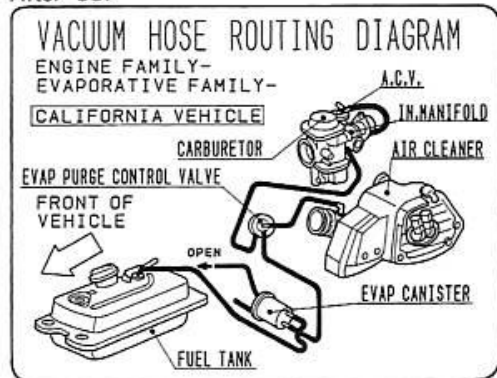

DRIVE BELT

Remove the left rear cover (page 13-2) and left crankcase cover (page 8-3).
 Inspect the drive belt for cracks, abnormal or excessive wear and replace if necessary (page 8-3).
 Replace the drive belt with a new one when indicated by the maintenance schedule (page 3-2 or 3-3).

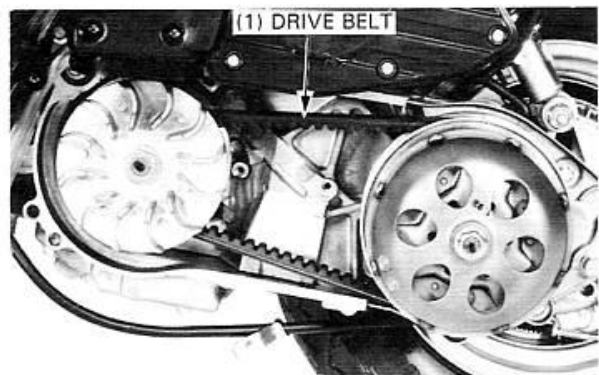

Inspect the drive and driven pulley faces for wear or damage and replace if necessary (page 8-4, 8).

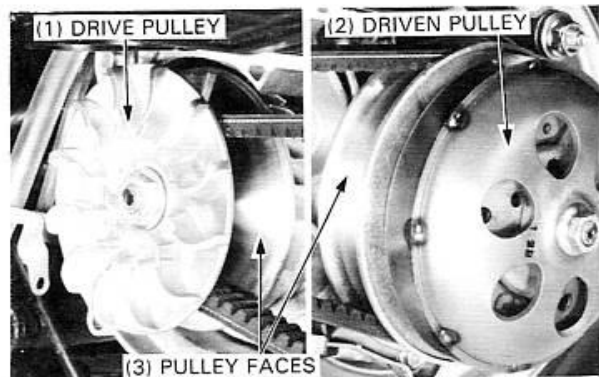

MAINTENANCE

BELT CASE AIR CLEANER

Remove the left rear cover (page 13-2).
Remove the belt case air cleaner cover by removing the two screws.

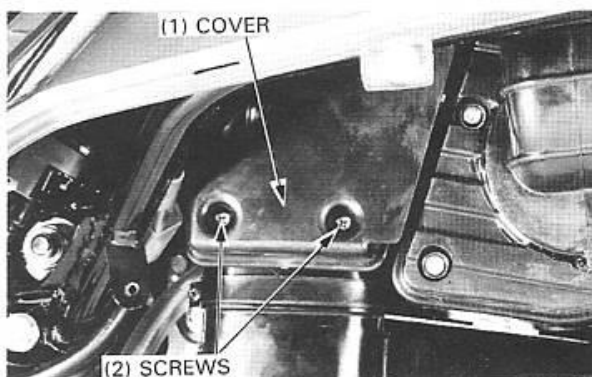

Remove the element from the belt case air cleaner and wash the element in non-flammable or high flash-point solvent, squeeze out the solvent thoroughly, and let it dry.

CAUTION

- Do not oil the element.
- Dry the element completely before installing.

Install the element and cover in the reverse order of removal.

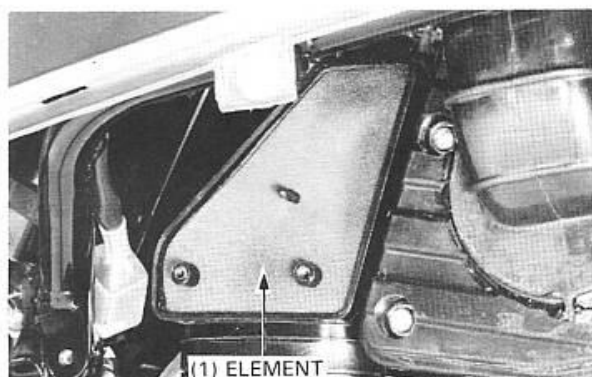

BRAKE FLUID

Check the front brake fluid reservoir level.

If the brake fluid level nears the lower level, check the entire system for leaks, and fill the brake reservoir.

CAUTION

- Do not remove the reservoir cap until the handlebar has been turned so that the reservoir is level.
- Do not mix different types of fluid. They are not compatible.
- Do not allow foreign material to enter the system when filling the reservoir.
- Avoid spilling fluid on painted, plastic or rubber parts. Place a rag over the parts whenever the system is serviced.

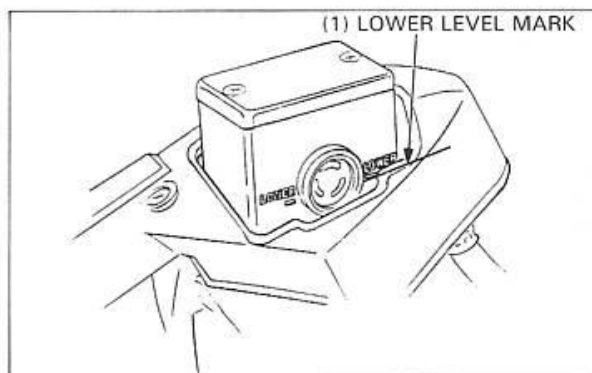

BRAKE FLUID FILLING

Remove the two reservoir cap attaching screws, reservoir cap and diaphragm.

Fill the reservoir with DOT 3 or DOT 4 brake fluid to the upper level.

(1) UPPER LEVEL MARK



BRAKE SHOE/PAD WEAR

REAR BRAKE SHOE

Replace the brake shoes when the arrow on the brake arm aligns with the reference mark "▲" on the left crankcase, when the rear brake is applied fully.

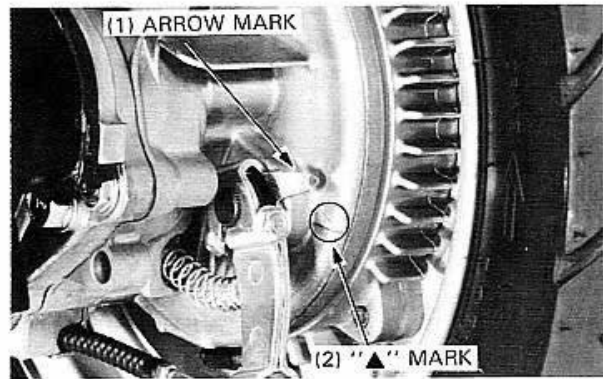

FRONT BRAKE PAD

Check the brake pads for wear by looking through the slot indicated by the arrow cast on the caliper assembly.

Replace the brake pads if either wear line on the brake pads reaches the edges of the brake disc (page 16-5).

NOTE

- Always replace the brake pads in pairs to assure even disc pressure.

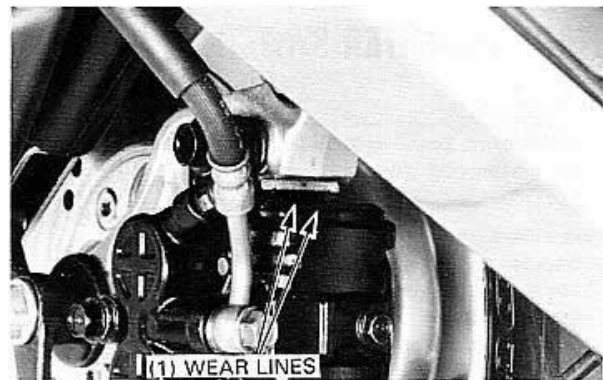

BRAKE SYSTEM

FRONT BRAKE

Inspect the front brake hose and fittings for deterioration, cracks or signs of leakage.
Tighten any loose fittings.
Replace the hose and fittings as required.

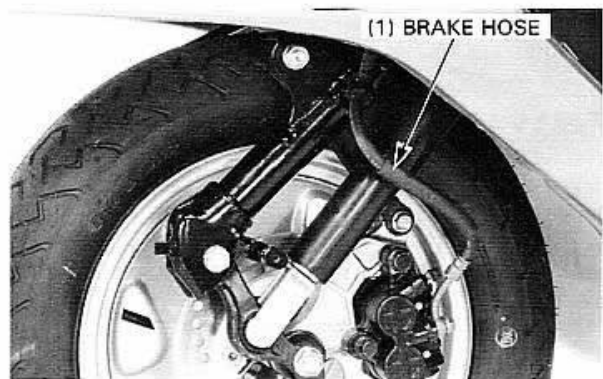

REAR BRAKE

Measure the rear brake pedal free play at the top of the pedal.

FREE PLAY: 20–30 mm (3/4–1-1/8 in)

NOTE

- Normal distance between the top of the brake pedal and the floor board is 30–40 mm (1-1/8–1-1/2 in) with the pedal depressed.

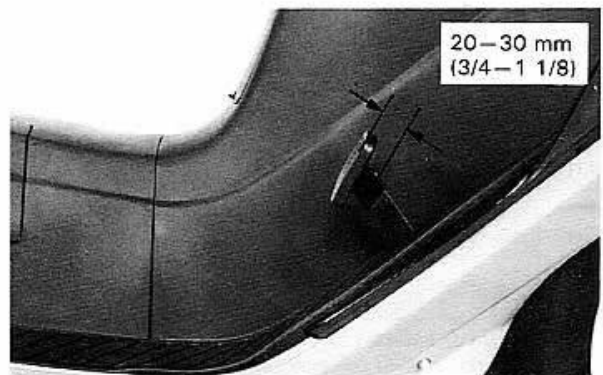

MAINTENANCE

Adjust the rear brake by turning the rear brake adjusting nut.

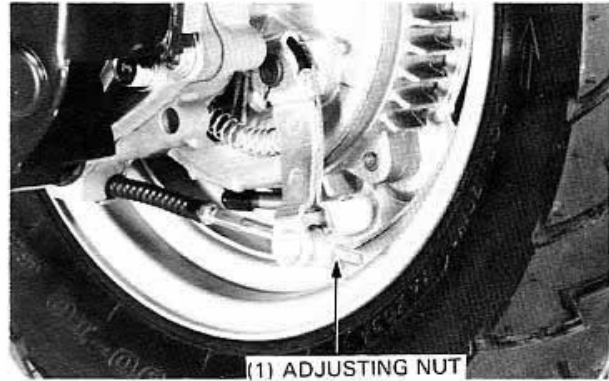

BRAKE LIGHT SWITCH/ STARTER LIMITER SWITCH

NOTE

- Perform the brake light switch adjustment after adjusting the brake pedal play.

Adjust the brake light/starter limiter switch as follows.

- Depress the brake pedal about 45–50 mm (1-3/4–2.0 in).
- Move the adjustment nut so that the starter will engage at that point.
- The rear brake adjustment should be such that the rear wheel is locked when the starter engages.

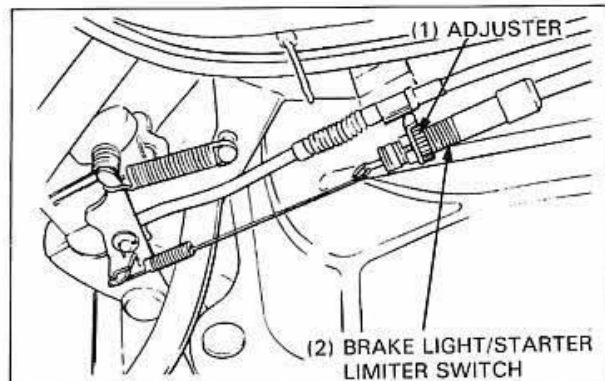

After adjustment, check the brake switch operation. The brake light should come on when depressing the brake pedal 5–20 mm (0.2–0.8 in).

BRAKE LOCK LEVER

Check the brake lock lever for smooth operation.

If the lock lever does not return smoothly when released, remove the brake lock cover and apply grease to the brake lock pin, sliding surface of the cam and brake lock cam pivot (page 15-7).

Refer to page 15-7 for brake lock adjustment.



HEADLIGHT AIM

Remove the maintenance cover (page 13-4).

Adjust horizontally by turning the horizontal adjusting screw.

Adjust vertically by turning the vertical adjusting screw.

NOTE

- Adjust the headlight beam as specified by local laws and regulations.

WARNING

- An improperly adjusted headlight may blind oncoming drivers, or it may fail to light the road for a safe distance.



FUEL SYSTEM

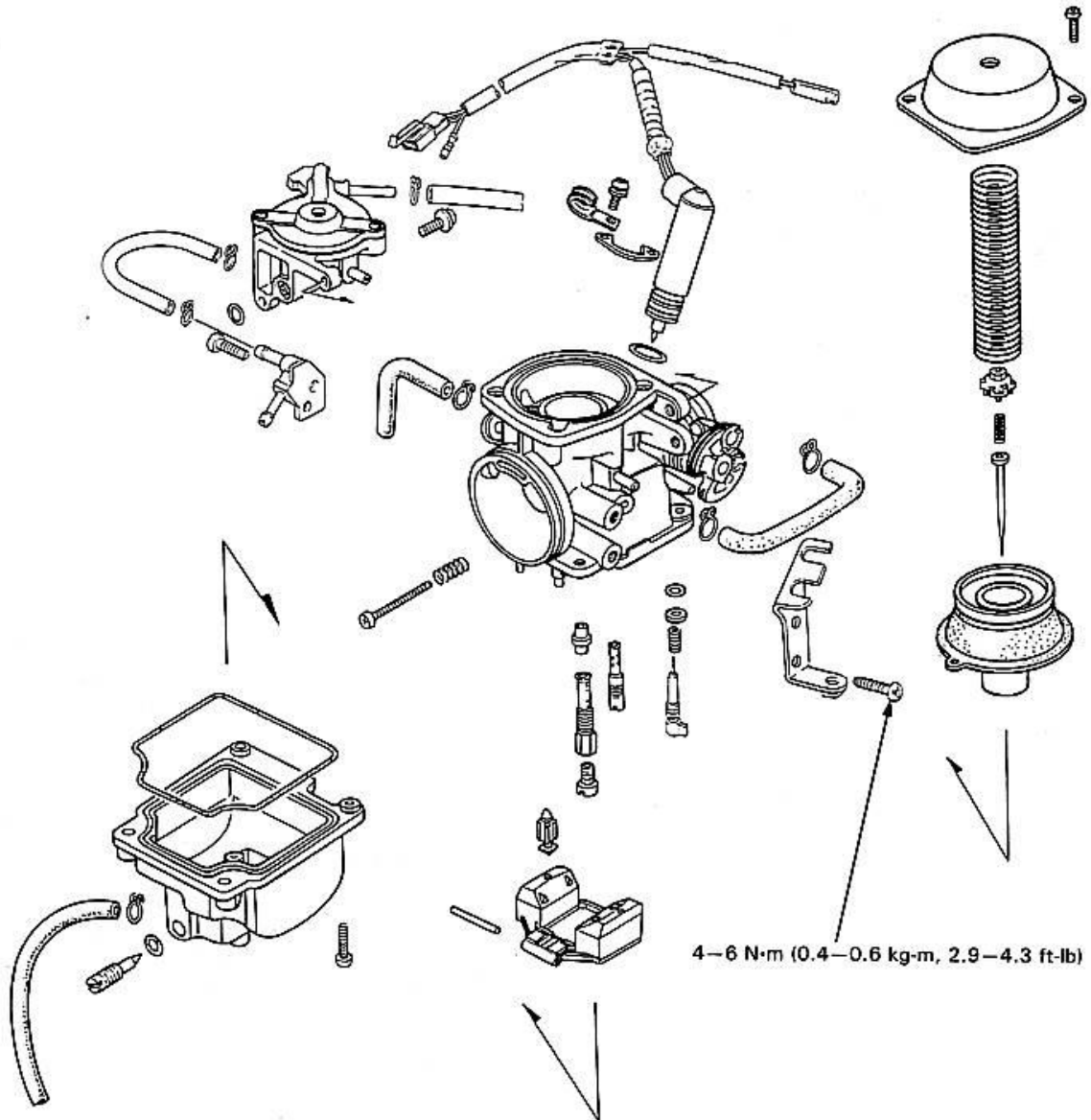

4. FUEL SYSTEM

SERVICE INFORMATION	4-1	PILOT SCREW ADJUSTMENT	4-11
TROUBLESHOOTING	4-2	LIMITER CAP INSTALLATION	4-12
CARBURETOR REMOVAL	4-3	HIGH ALTITUDE ADJUSTMENT	4-12
STARTING ENRICHMENT (SE)		FUEL TANK	4-13
THERMAL VALVE	4-4	FUEL UNIT	4-14
VACUUM CHAMBER	4-5	AIR CLEANER HOUSING	4-14
AIR CUT-OFF VALVE	4-6	EVAPORATIVE EMISSION (EVAP)	
PILOT SCREW	4-7	PURGE CONTROL VALVE INSPECTION (California type only)	4-15
FLOAT/FLOAT VALVE/JETS	4-7		
CARBURETOR INSTALLATION	4-9		

SERVICE INFORMATION

GENERAL

WARNING

- *Gasoline is extremely flammable and is explosive under certain conditions. Work in a well ventilated area. Do not smoke or allow flames or sparks in the work area.*

- When disassembling the fuel system parts, note the location of the O-rings. Replace them with new ones on reassembly.
- Before disassembling the carburetor, drain the fuel in the float chamber by turning the drain screw.
- Do not try to disassemble the auto bystarter and air cut-off valve.
California model:
- Refer to the label on the left side of the battery box for the hose connections for the evaporative emission control system.

CAUTION

- *Do not bend or twist control cables. Damaged control cables will not operate smoothly and may stick or bind.*

SPECIFICATIONS

ITEM			STANDARD
Identification number	'86-'87:	49 state	VE14A
		California	VE15A
	After '91:		VE43A
Venturi diameter			27.3 mm (1.07 in)
Float level			18.5 ± 1.0 mm (0.73 ± 0.04 in)
Main jet number			#110
Slow jet number			#38
Idle speed			1500 ± 100 rpm
Pilot screw opening (initial)			See page 4-11
Throttle grip free play			2-6 mm (1/8-1/4 in)

FUEL SYSTEM

TORQUE VALUES

Fuel tank drain bolt	40–60 N·m (4.0–6.0 kg-m, 29–43 ft-lb)
Throttle cable stay screw	4–6 N·m (0.4–0.6 kg-m, 2.9–4.3 ft-lb) Apply a locking agent

TOOLS

Special

Vacuum/pressure pump or Vacuum pump	A937X-041-XXXXX
Pressure pump	ST-AH-260-MC7 (U.S.A. only)
Pilot screw wrench	ST-AH-255-MC7 (U.S.A. only)
	07908–4730000 or equivalent commercially available in U.S.A. (Cal-Van 466)

Common

Float level gauge	07401–0010000
-------------------	---------------

TROUBLESHOOTING

Engine cranks but won't start

- No fuel in tank
- No fuel to carburetor
- Engine flooded with fuel
- No spark at plug (faulty ignition system)
- Clogged air cleaner
- Intake air leak
- Improper starting enrichment (SE) thermal valve operation
- Improper throttle operation
- Faulty fuel pump

Hard starting or stalling after starting

- Improper starting enrichment (SE) thermal valve operation
- Ignition malfunction
- Faulty carburetor
- Contaminated fuel
- Intake air leak
- Incorrect idle speed
- Faulty fuel pump

Rough idle

- Faulty ignition system
- Incorrect idle speed
- Faulty carburetor
- Contaminated fuel

Misfiring during acceleration

- Faulty ignition system

Backfiring

- Faulty ignition system
- Faulty carburetor
- Faulty air cut-off valve

Poor performance (driveability) and poor fuel economy

- Clogged fuel system
- Faulty ignition system
- Faulty fuel pump
- Faulty components in the evaporative emission control system (California type only)

Lean mixture

- Clogged fuel jets
- Stuck vacuum piston
- Faulty float valve
- Low float level
- Blocked fuel cap vent
- Clogged fuel strainer screen
- Restricted fuel line
- Clogged air vent tube
- Intake air leak
- Faulty fuel pump

Rich mixture

- Clogged air jets
- Faulty float valve
- Float level too high
- Faulty starting enrichment (SE) thermal valve
- Dirty air cleaner
- Faulty air cut-off valve

CARBURETOR REMOVAL

Remove the seat (page 13-2).
Loosen the air chamber and air cleaner connecting tube bands.
Remove the air chamber screw and air chamber.

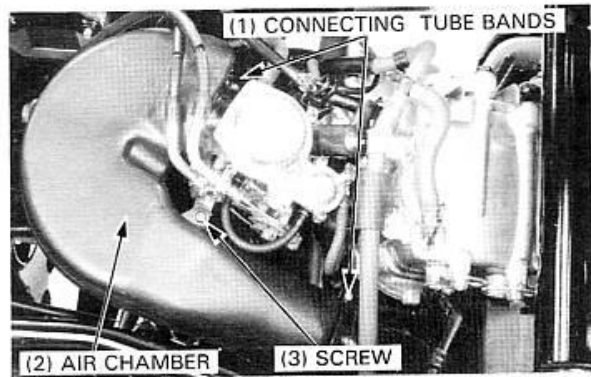

Loosen the throttle cable adjusting nuts and lock nuts.
Disconnect the throttle cables from the carburetor.

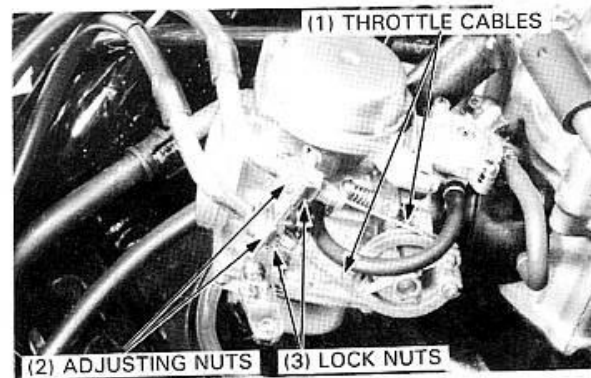

Disconnect the heater tube from the carburetor heater.
Disconnect the fuel tube from the carburetor.

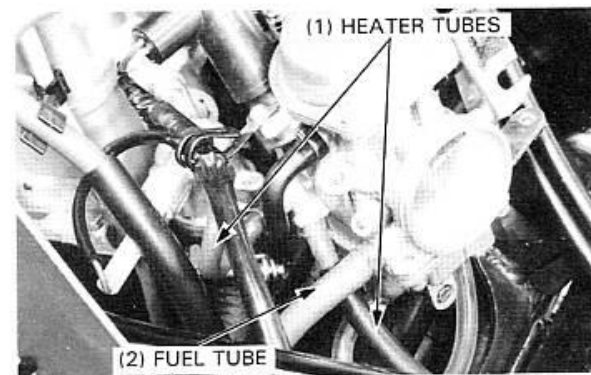

Disconnect the vacuum tube from the air cut-off valve.
Loosen the carburetor insulator band and remove the carburetor from the insulator.

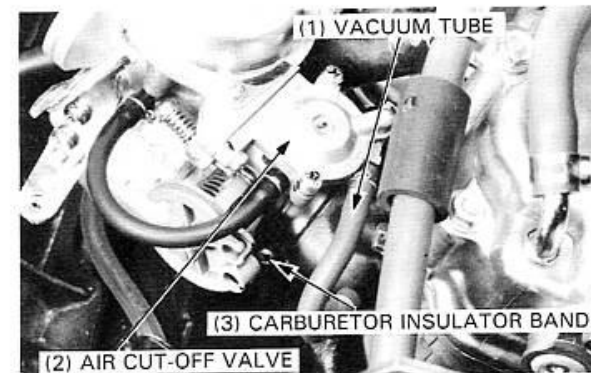

FUEL SYSTEM

Remove the set plate screws, set plate and starting enrichment (SE) thermal valve from the carburetor.

NOTE

- The trunk cover must be removed to disconnect the SE thermal valve wire coupler. Be careful not to damage the valve and needle.

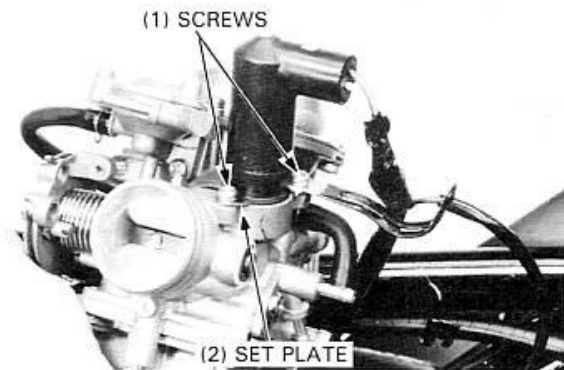

STARTING ENRICHMENT (SE) THERMAL VALVE

INSPECTION

Stop the engine and wait at least 10 minutes, then measure the resistance between the wire terminals.

RESISTANCE: Aprox. 10 Ω

If the reading is not within the limit, replace the SE thermal valve with a new one.

Connect a 12V battery to the SE thermal valve wires and wait about 5 minutes. Connect a pressure tester to the fuel enrichment circuit and apply a light pressure. Replace the SE thermal valve if there is no resistance to the applied pressure.

Disconnect the battery and wait 30 minutes. Connect the pressure tester to the enrichment circuit. Apply pressure to the circuit. If there is resistance to the pressure, replace the SE thermal valve.

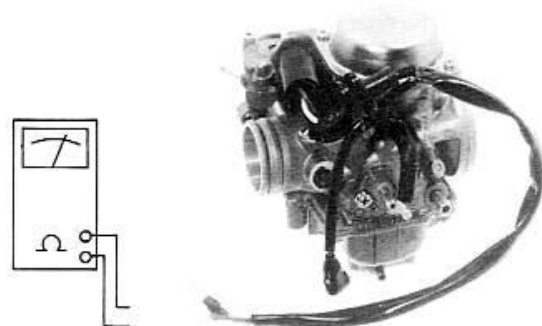

(1) PRESSURE TESTER TUBE



(2) FUEL ENRICHMENT CIRCUIT

VALVE INSPECTION

Check the valve and needle for wear, or other damage.

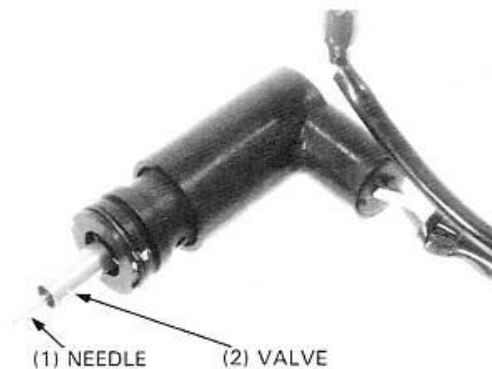

VACUUM CHAMBER

DISASSEMBLY

Loosen the drain screw and drain the fuel from the float chamber.

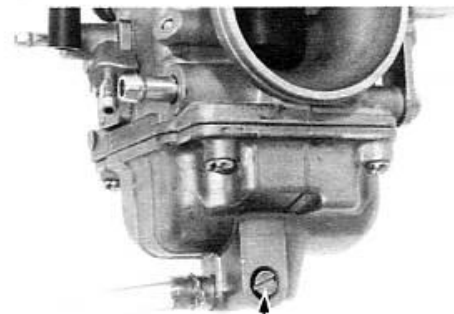

(1) DRAIN SCREW

Remove the two vacuum chamber cover screws and cover.

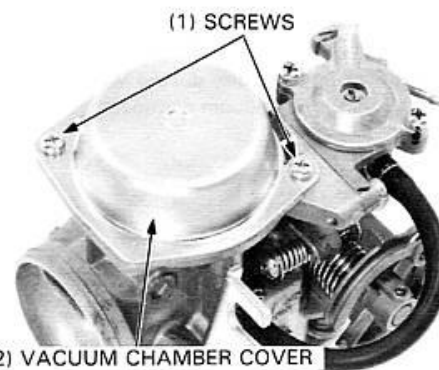

(1) SCREWS

(2) VACUUM CHAMBER COVER

Remove the compression spring and the vacuum piston.

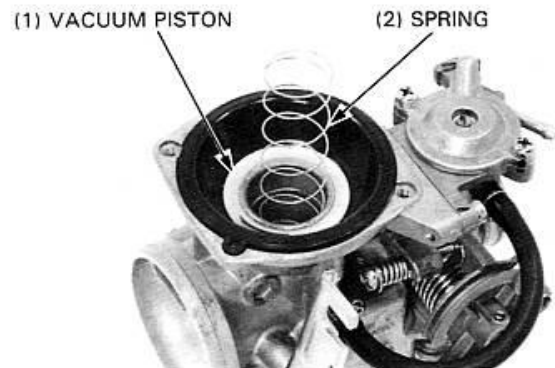

(1) VACUUM PISTON

(2) SPRING

Push the needle holder in and turn it 60° with an 8 mm socket. Then remove the needle holder, spring and jet needle from the piston.

Inspect the vacuum piston for wear, or other damage. Inspect the needle for excessive wear, bending, or other damage.

Check the diaphragm for deterioration and tears.

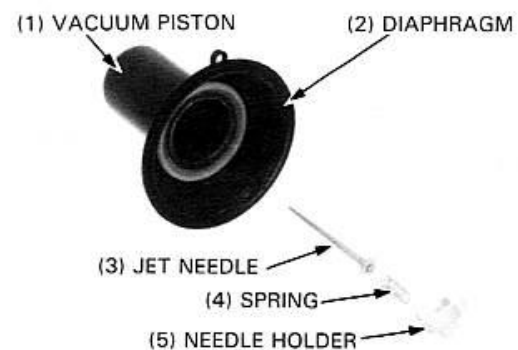

(1) VACUUM PISTON

(2) DIAPHRAGM

(3) JET NEEDLE

(4) SPRING

(5) NEEDLE HOLDER

FUEL SYSTEM

ASSEMBLY

Install the jet needle, spring and needle holder into the vacuum piston, push the needle holder in and turn it 60°. Insert the vacuum piston into the carburetor. Stick your finger into the carburetor bore and hold the vacuum piston in the full throttle position, then turn down the diaphragm so its lip fits into the carburetor groove. Install the compression spring as shown.

NOTE

- Be careful not to distort the diaphragm. If the diaphragm cannot be positioned correctly because of its expansion, dry the diaphragm before installation.

Install the vacuum chamber cover, aligning its cavity with the hole in the carburetor, and secure with at least two screws before releasing the vacuum piston.

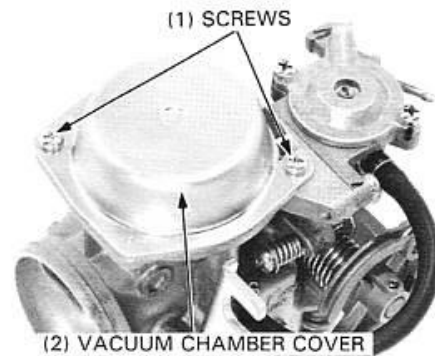
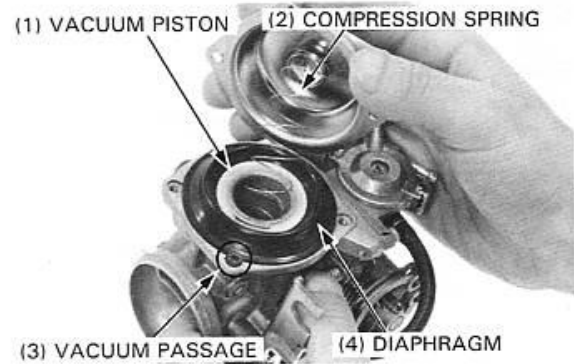

AIR CUT-OFF VALVE

INSPECTION

Disconnect the vacuum tube and air vent tube from the air cut-off valve. Connect the vacuum pump to the vacuum tube connector. Connect the pressure pump to the air vent tube connector. Apply specified vacuum, then pump the pressure pump.

SPECIFIED VACUUM: Aprox. 380 mm Hg (14.96 in Hg)

The air cut-off valve is normal if the pressure does not flow out from the air cut-off valve outlet. If the pressure flows out, replace the air cut-off valve assembly.

REPLACEMENT

Remove the carburetor. Disconnect the air vent tube from the air cut-off valve. Remove the valve body screws and valve.

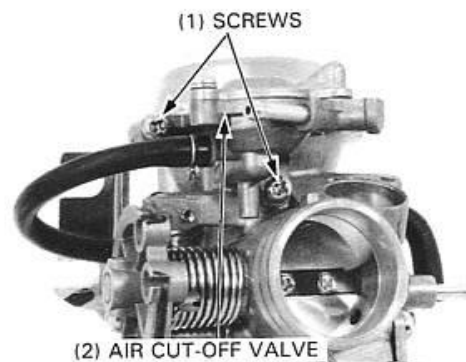
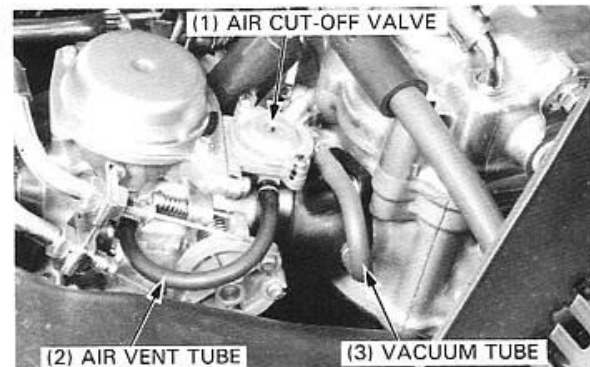

Install a new O-ring onto the air cut-off valve with its flat face toward the valve side.
Install the valve to the carburetor using the two screws.

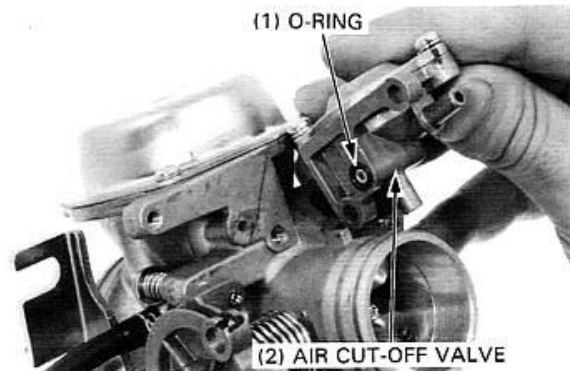

PILOT SCREW

REMOVAL

NOTE

- The pilot screw is factory pre-set and should not be removed unless the carburetor is overhauled.
- The pilot screw limiter cap is factory installed and cemented in place to prevent pilot screw misadjustment.

Remove the carburetor (page 4-3).
Remove the pilot screw limiter cap.
Turn the pilot screw in and carefully count the number of turns before it seats lightly. Make a note of this to use as a reference when reinstalling the pilot screw.

CAUTION

- *Damage to the pilot screw seat will occur if the pilot screw is tightened against the seat.*

Remove the pilot screw.
Inspect the pilot screw and replace if worn or damaged.
Install the pilot screw and return it to the original position as noted during removal.
Perform the pilot screw adjustment if a new pilot screw is installed (page 4-11).

NOTE

- Do not install the limiter cap on a new pilot screw until after adjustment has been made (page 4-11).

Install the carburetor.

FLOAT/FLOAT VALVE/JETS

DISASSEMBLY

Remove the four float chamber screws and the float chamber.

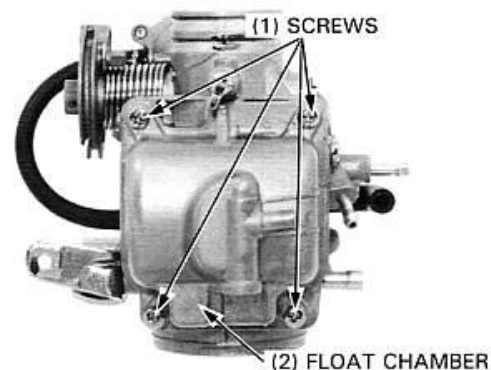
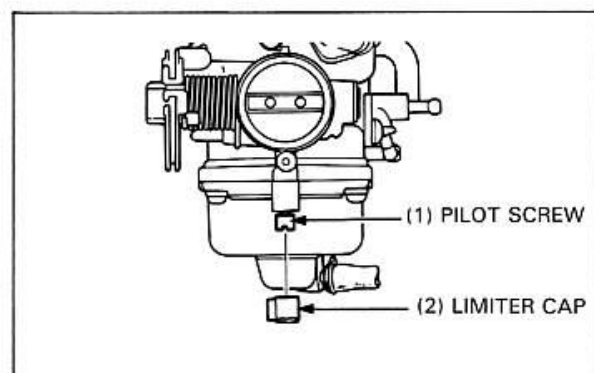

FUEL SYSTEM

Remove the float pin, float and float valve.

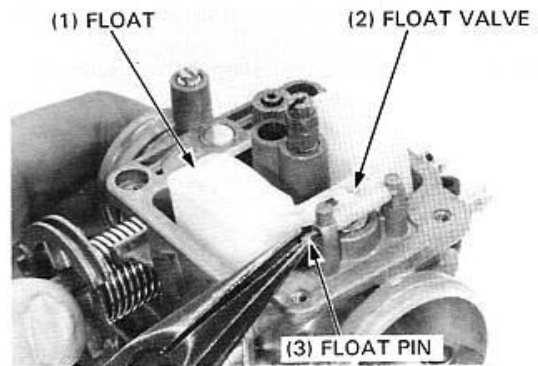

FLOAT VALVE INSPECTION

Inspect the float valve for grooves and nicks.
Inspect the operation of the float valve.

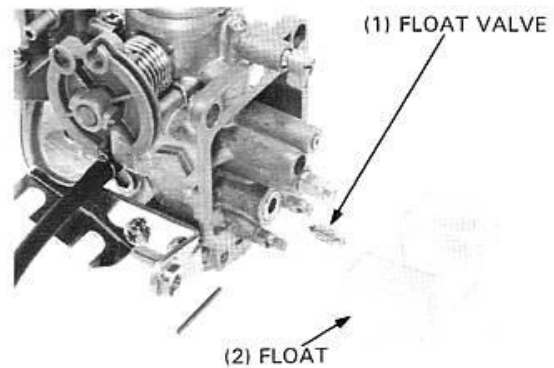

Remove the main jet, needle jet holder and needle jet.
Remove the slow jet.

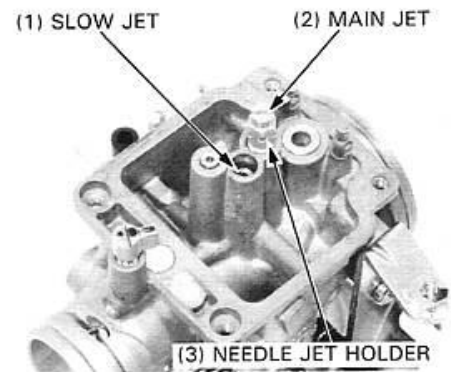

Blow open all passages with compressed air before assembling.

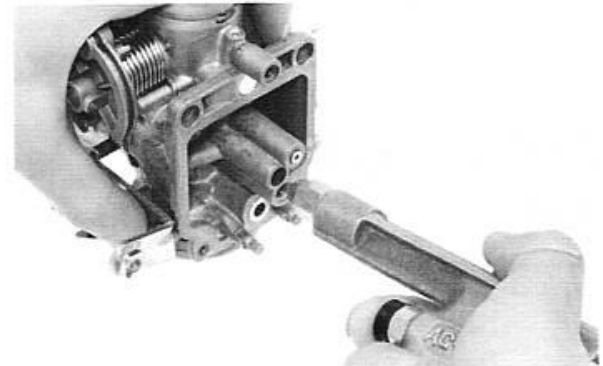

ASSEMBLY

Clean the main jet, needle jet holder, needle jet and slow jet in cleaning solvent and blow them open with compressed air. Install the needle jet and needle jet holder. Install the main jet and slow jet.

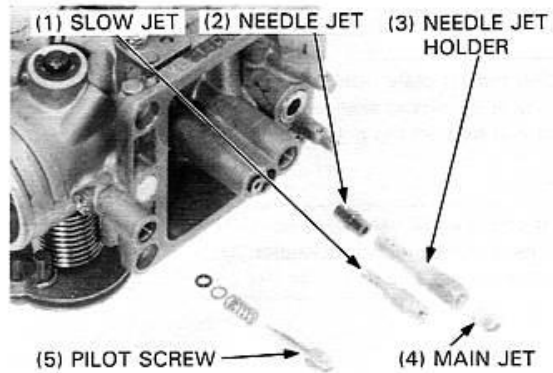

Install the float valve, float and float pin.

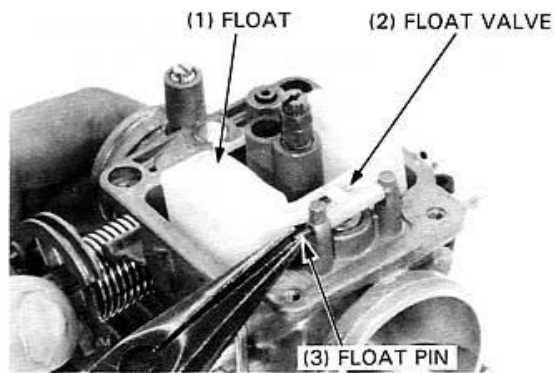

FLOAT LEVEL INSPECTION

Measure the float level with the float tang just contacting the float valve.

FLOAT LEVEL: 18.5 ± 1.0 mm
(0.73 ± 0.04 in)

TOOL:
Float level gauge 07401-0010000

Replace the float if the level is not within the limit.
Reinstall the float chamber.

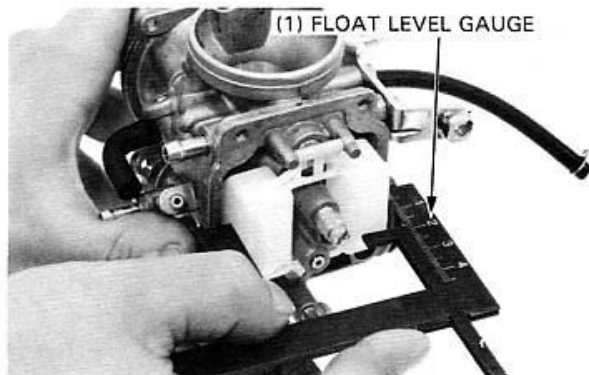

CARBURETOR INSTALLATION

Tighten the drain screw.
Connect the drain tube to the carburetor.

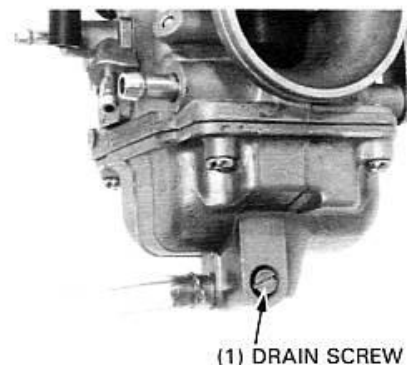

FUEL SYSTEM

Insert the SE thermal valve into the carburetor body until it bottoms.

Position the set plate into the upper groove in the SE thermal valve with its closed side toward the carburetor.

Install and tighten the set screws.

NOTE

- If the SE thermal valve wire coupler is disconnected from the harness, reconnect the coupler.
- Install the set plate with its flat edge facing up.

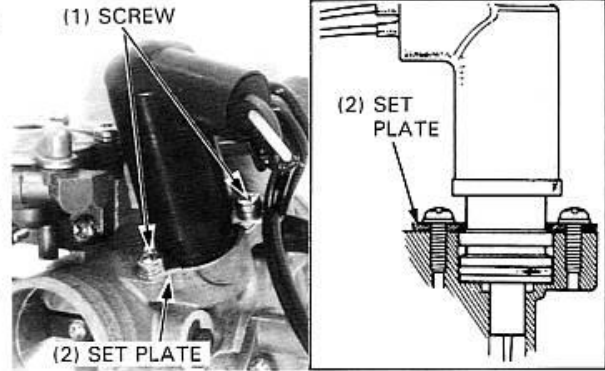

Install the carburetor aligning the tab on the carburetor with the groove in the carburetor insulator and tighten the insulator band screw.

Connect the vacuum tube to the air cut-off valve vacuum fitting.

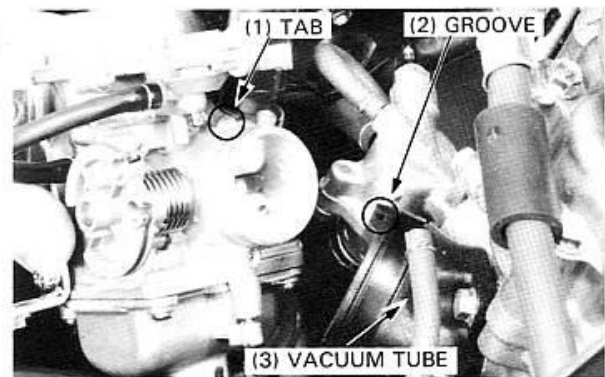

Connect the heater tubes to the carburetor heater.

Connect the fuel tube securely.

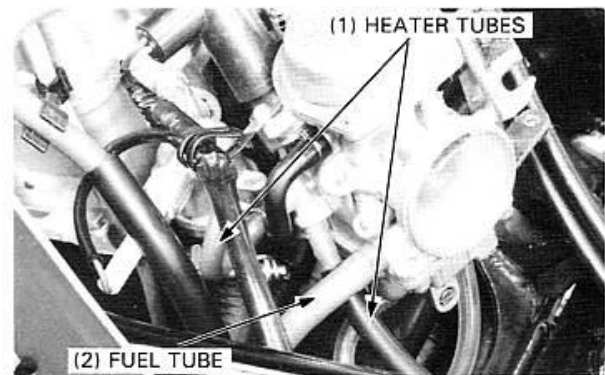

Connect the throttle cables to the carburetor.

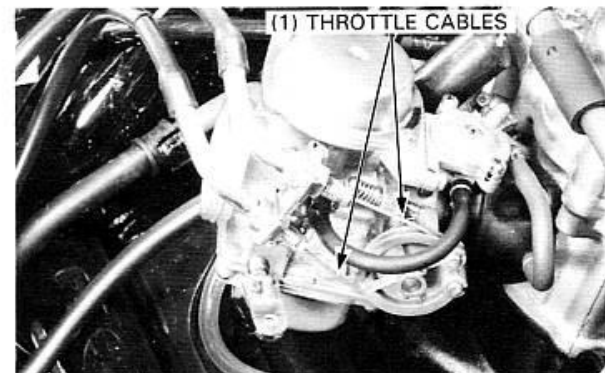

Install the air chamber and tighten the air chamber and air cleaner connecting tube bands.

Install and tighten the air chamber screw.

Adjust the following:

- throttle grip free play (page 3-4)
- idle speed (page 3-7)

Install the seat (page 13-2).

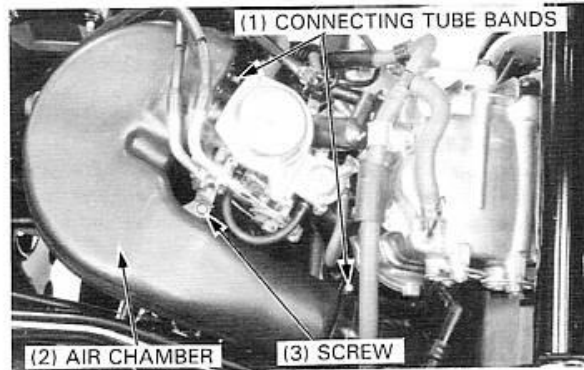

PILOT SCREW ADJUSTMENT

IDLE DROP PROCEDURE (U.S.A. ONLY)

NOTE

- The pilot screw is factory pre-set and no adjustment is necessary unless the pilot screw is replaced (page 4-7).
- Use a tachometer with graduations of 100 rpm or smaller that will accurately indicate a 100 rpm change.

1. Remove the seat and right rear cover (page 13-2).
2. Remove the limiter cap from the pilot screw.
3. Turn the pilot screw clockwise until it seats lightly and back it out to the specification given. This is an initial setting prior to the final pilot screw adjustment.

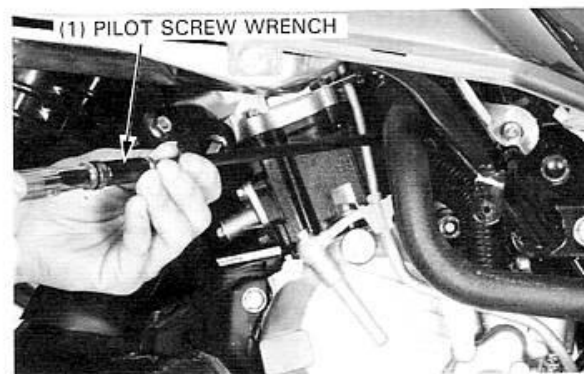

INITIAL OPENING: '86–'87: 2-1/2 turns out
: After '91: 2-1/4 turns out

TOOL:

Pilot screw wrench **07908–4730000 or**
equivalent commercially
available in U.S.A.

CAUTION

- *Damage to the pilot screw seat will occur if the pilot screw is tightened against the seat.*

4. Warm up the engine to operating temperature. Stop and go driving for 10 minutes is sufficient.
5. Attach a tachometer according to the manufacturer's instructions.
6. Adjust the idle speed with the throttle stop screw.

IDLE SPEED: 1500 ± 100 rpm

7. Turn the pilot screw in or out slowly to obtain the highest engine speed.
8. Readjust the idle speed with the throttle stop screw.
9. Turn the pilot screw in gradually until the engine speed drops 100 rpm.
10. Turn the pilot screw 1 turn out from the position obtained in step 9.
11. Readjust the idle speed with the throttle stop screw.
12. Install a new limiter cap (page 4-12).

FUEL SYSTEM

LIMITER CAP INSTALLATION

If the pilot screw is replaced, a new limiter cap must be installed after pilot screw adjustment is completed.

After adjustment, cement the limiter caps over the pilot screws, using LOCTITE® 601 or equivalent.

The limiter cap should be placed against its stop, preventing further adjustment that would enrich the fuel mixture (correct limiter cap position permits clockwise rotation and prevents counterclockwise rotation).

NOTE

- Do not turn the pilot screw when installing the limiter cap.

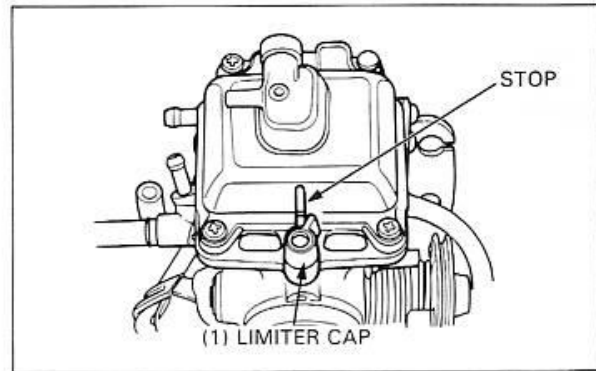

HIGH ALTITUDE ADJUSTMENT

If the scooter is to be operated continuously above 2,000 m (6,500 feet), the carburetor must be readjusted to improve drivability and decrease exhaust emissions.

Warm up the engine to normal operating temperature. Stop and go driving for 10 minutes is sufficient.

Remove the seat and right rear cover (page 13-2).

Turn the pilot screw clockwise 1/4 turn.

TOOL:

Pilot screw wrench **07908—4730000 or equivalent commercially available in U.S.A.**

Adjust the idle speed to $1,500 \pm 100$ rpm with the throttle stop screw.

NOTE

- This adjustment must be made at high altitude to ensure proper high altitude operation.

Attach a Vehicle Emission Control Information Update Label onto the inside of the trunk lid as shown. Refer to Service Bulletin #132 for information on obtaining the label.

NOTE

- Do not attach the label to any part that can be easily removed from the scooter.

WARNING

- *Operation at an altitude lower than 1,500 m (5,000 feet) with the carburetor adjusted for high altitudes may cause the engine to idle roughly and stall.*

When the scooter is to be operated continuously below 1,500 m (5,000 feet), turn the pilot screw counterclockwise 1/4 turn to its original position and adjust the idle speed to 1,500 rpm.

Be sure to do these adjustments at low altitude.

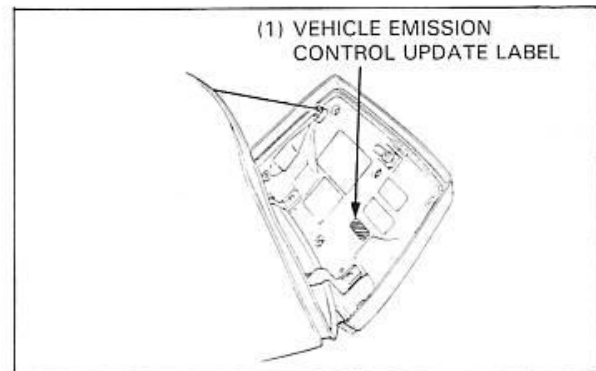
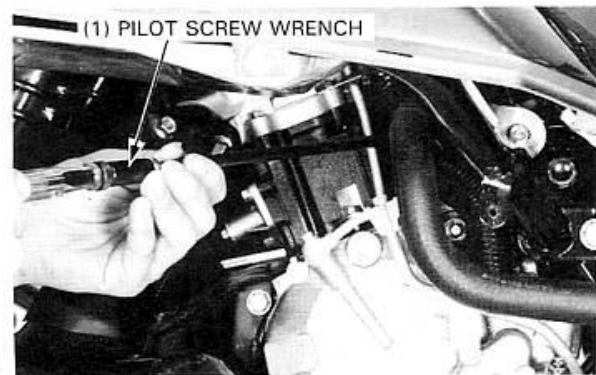

	STANDARD (BELOW 1500 m, 5,000 ft)	HIGH ALTITUDE (ABOVE 2,000 m, 6,500 ft)
MAIN JET No.	No. 110	No. 108
PILOT SCREW INITIAL OPENING	2-1/4	2
Idle speed	1500 ± 100 rpm	1500 ± 100 rpm

FUEL TANK

REMOVAL

Remove the drain bolt and drain the fuel tank.

WARNING

- *Do not smoke or allow flames or sparks in the work area.*

Remove the floor panel and inner box (section 13).
Remove the right water pipe from the frame.
Disconnect the fuel unit coupler.
Disconnect the fuel tube.
Remove the fuel tank mounting bolts and fuel tank.

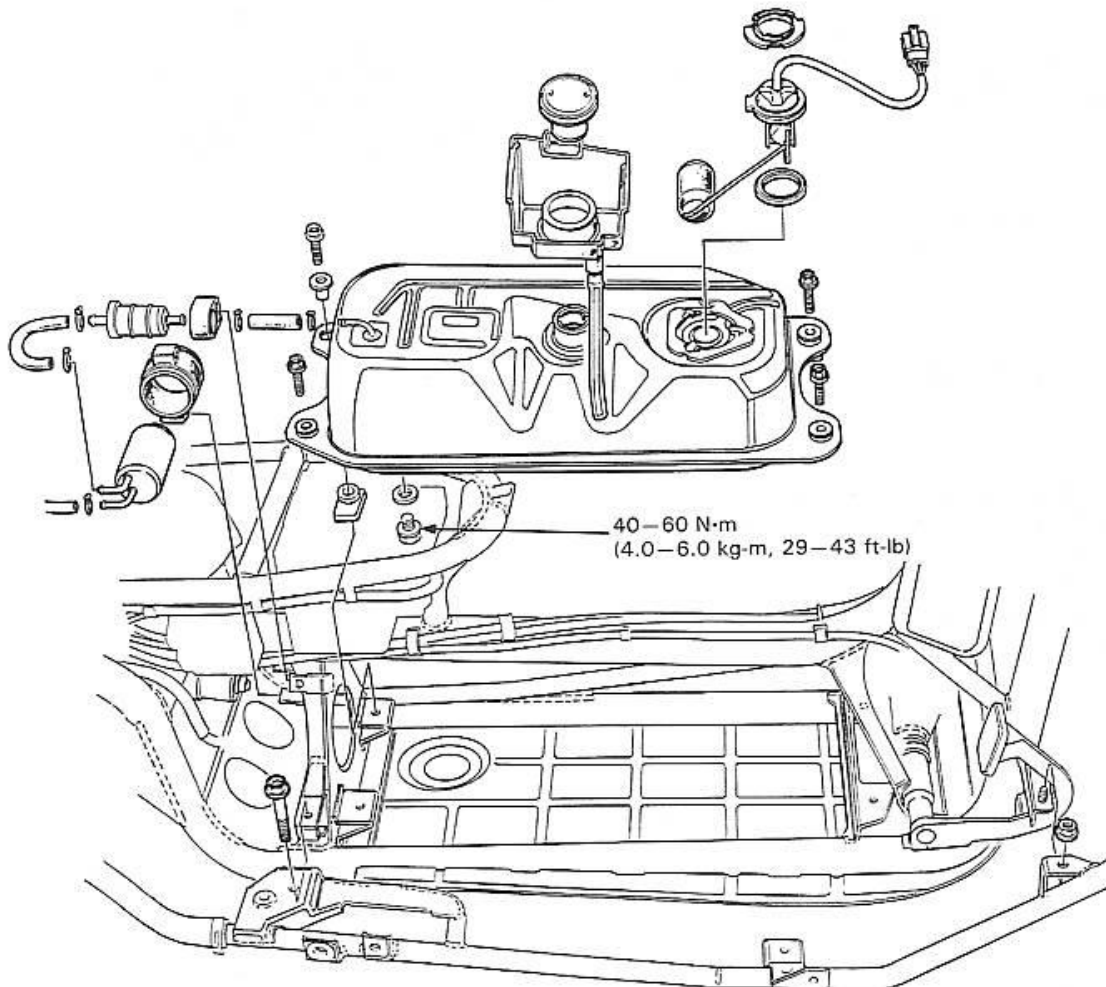

FUEL SYSTEM

FUEL UNIT

Remove the fuel tank (page 4-13).
Turn the fuel unit retainer counterclockwise and remove the fuel unit from the fuel tank.

NOTE

- Do not damage or bend the float and float arm.

INSTALLATION

Check the fuel unit seal for damage or deterioration and replace if necessary.
Install the fuel unit onto the fuel tank aligning the tab on the fuel tank with the slot in the fuel unit.
Install the fuel unit retainer.

NOTE

- Make sure that the arrow mark on the retainer aligns with the mark on the fuel tank.

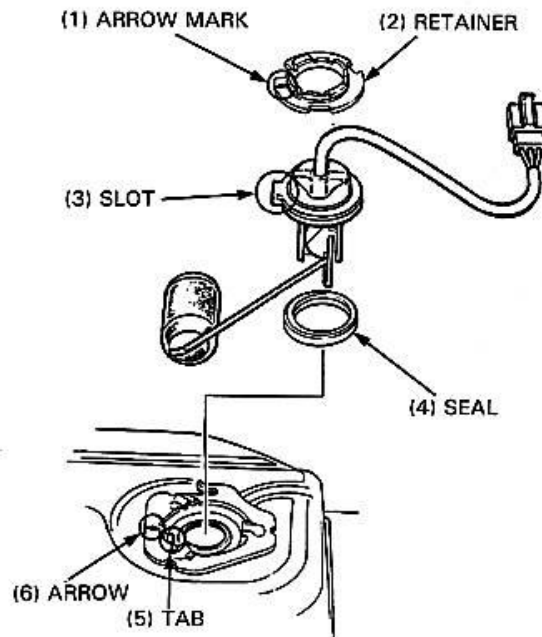

AIR CLEANER HOUSING

REMOVAL

Remove the seat and left rear cover (page 13-2).
Remove the air cleaner housing upper mount bolt from the cylinder head cover.
Remove the two air cleaner housing mounting bolts from the left crankcase.
Loosen the air cleaner connecting tube band and remove the air cleaner housing.

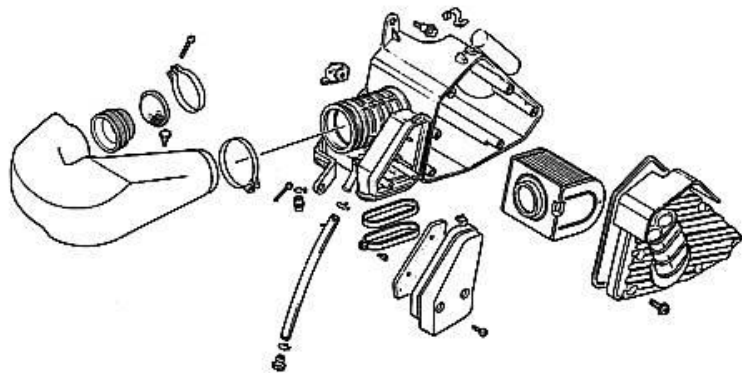

INSTALLATION

Install the air cleaner housing in the reverse order of removal.

NOTE

- Tighten the connecting tube band screw securely.

EVAPORATIVE EMISSION (EVAP) PURGE CONTROL VALVE INSPECTION (California type only)

NOTE

- The EVAP purge control valve should be inspected if hot restart is difficult.

Check all fuel tank, EVAP Purge Control Valve, and EVAP canister hoses to be sure they are not kinked and are securely connected.

Replace any hose that shows signs of damage or deterioration.

NOTE

- The EVAP purge control valve is located left side of air chamber.

Disconnect the EVAP purge control valve hoses from their connections and remove the EVAP purge control valve from its mount. Refer to the routing label on the left side of battery box for hose connections.

Connect a vacuum pump to the 8 mm I.D. hose that goes to the air cleaner. Apply the specified vacuum to the EVAP purge control valve.

SPECIFIED VACUUM: 250 mm (9.8 in) Hg

The specified vacuum should be maintained. Replace the EVAP purge control valve if vacuum is not maintained.

TOOL:

Vacuum pump **ST-AH-260-MC7**
(U.S.A. only)

Remove the vacuum pump and connect it to the hose that goes to the carburetor.

Apply the specified vacuum to the EVAP purge control valve.

SPECIFIED VACUUM: 250 mm (9.8 in) Hg

The specified vacuum should be maintained.

Replace the EVAP purge control valve if vacuum is not maintained.

Connect a pressure pump to the 8 mm I.D. hose that goes to the charcoal canister. While applying the specified vacuum to the EVAP purge control valve hose that goes to the carburetor, pump air through the EVAP canister hose. Air should flow through the EVAP purge control valve and out the hose that goes to the air cleaner. Replace the EVAP purge control valve if air does not flow out.

CAUTION

- To prevent damage to the EVAP purge control valve, do not use high air pressure sources. Use a hand operated air pump only.

TOOLS:

Vacuum pump **ST-AH-260-MC7**
(U.S.A. only)

Pressure pump **ST-AH-255-MC7**
(U.S.A. only)

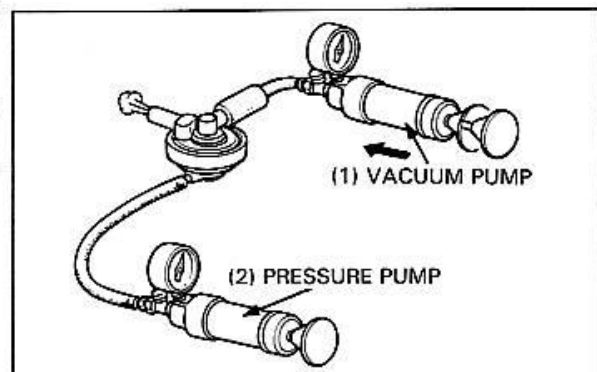
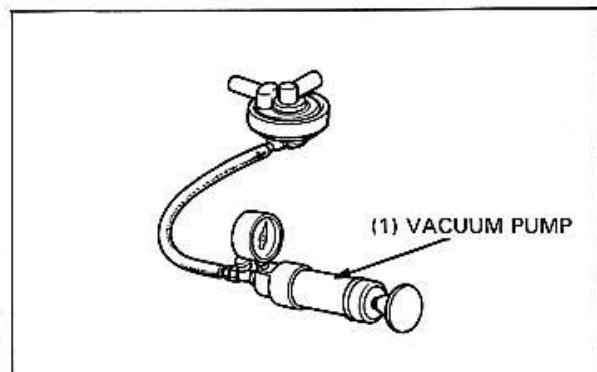
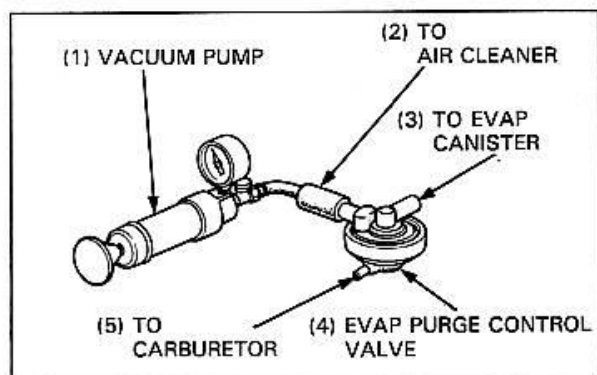
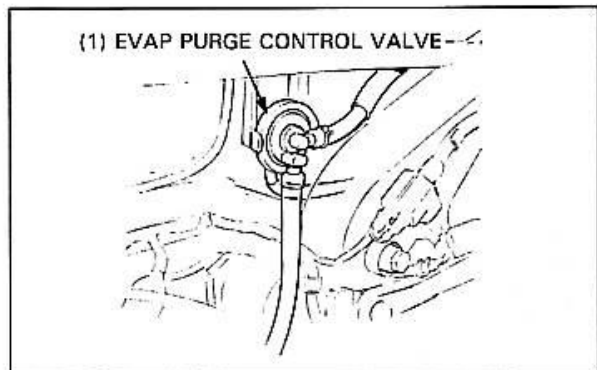

FUEL SYSTEM

Remove the pumps, install the EVAP purge control valve on its mount, route and reconnect the hoses according to the routing label on the left side of the battery box.

NOTE

- Be careful not to bend, twist or kink the tubes when installing.
- Slide the end of each tube onto its fitting fully and secure with the hose clamps.
- Secure with the hose clamps whenever specified.
- Check that the hoses are not contacting sharp edges or corners.

'86-'87, '92-'93:

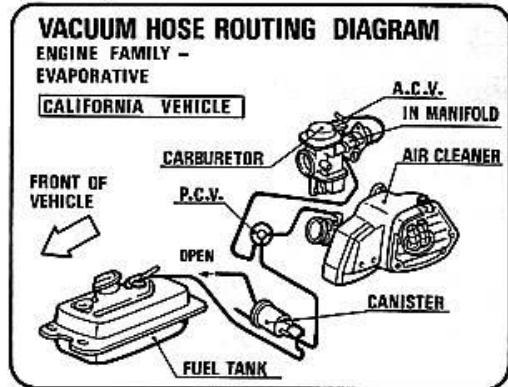

After '93:

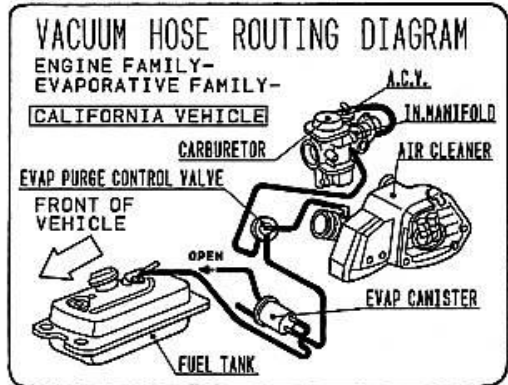

ENGINE REMOVAL/INSTALLATION

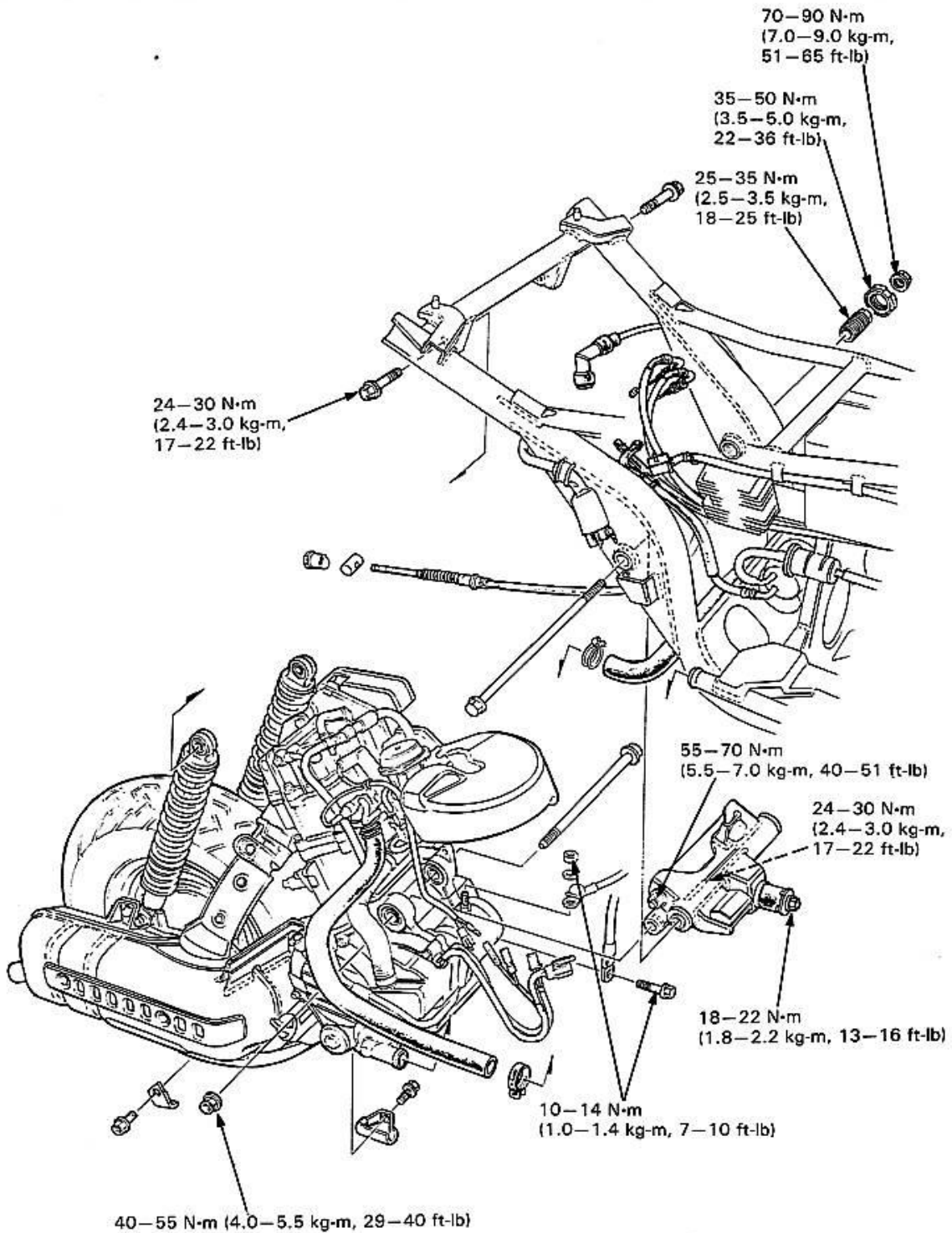

5. ENGINE REMOVAL/INSTALLATION

SERVICE INFORMATION	5-1	ENGINE HANGER	5-4
ENGINE REMOVAL	5-2	ENGINE INSTALLATION	5-5

SERVICE INFORMATION

GENERAL

A floor jack or other adjustable support is required to support and maneuver the engine.

SPECIFICATIONS

Engine dry weight		33 kg (73 lb)
Oil capacity	Engine	1.0 liter (1.06 US qt, 0.88 Imp qt) at disassembly 0.8 liter (0.85 US qt, 0.75 Imp qt) at change
	Transmission	0.20 liter (0.21 US qt, 0.18 Imp qt) at disassembly 0.15 liter (0.16 US qt, 0.13 Imp qt) at change
Coolant capacity	Engine and radiator	1.42 liter (1.50 US qt, 1.25 Imp qt)
	Reserve tank	0.40 liter (0.42 US qt, 0.35 Imp qt)
	Total	1.82 liter (1.93 US qt, 1.60 Imp qt)

TORQUE VALUES

Engine hanger stopper rubber bolt	18–22 N·m (1.8–2.2 kg-m, 13–16 ft-lb)
Engine hanger tension arm nut	24–30 N·m (2.4–3.0 kg-m, 17–22 ft-lb)
Engine hanger nut	55–70 N·m (5.5–7.0 kg-m, 40–51 ft-lb)
Engine pivot collar C	25–35 N·m (2.5–3.5 kg-m, 18–25 ft-lb)
Pivot collar lock nut	35–50 N·m (3.5–5.0 kg-m, 22–36 ft-lb)
Engine hanger mounting bolt	70–90 N·m (7.0–9.0 kg-m, 51–65 ft-lb)
Engine mounting bolt	40–55 N·m (4.0–5.5 kg-m, 29–40 ft-lb)
Rear shock absorber upper mounting bolt	24–30 N·m (2.4–3.0 kg-m, 17–22 ft-lb)
Starter motor cable nut	10–14 N·m (1.0–1.4 kg-m, 7–10 ft-lb)
Starter motor mounting bolt	10–14 N·m (1.0–1.4 kg-m, 7–10 ft-lb)

TOOL

Pin Spanner	07702–0020001
-------------	---------------

ENGINE REMOVAL/INSTALLATION

ENGINE REMOVAL

Remove the seat, rear frame and body center cover (section 13).

Remove the battery (page 17-2).

Drain the engine oil (page 2-2).

Drain the coolant (page 12-3).

Disconnect the cables from the starter motor.

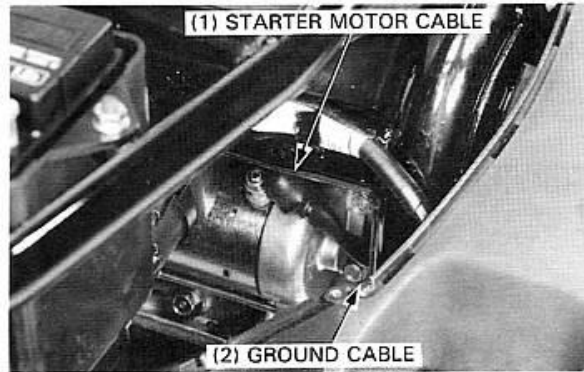

Disconnect the auto bystarter, thermosensor, pulse generator and alternator wire couplers and connectors, and remove the wire clamps.

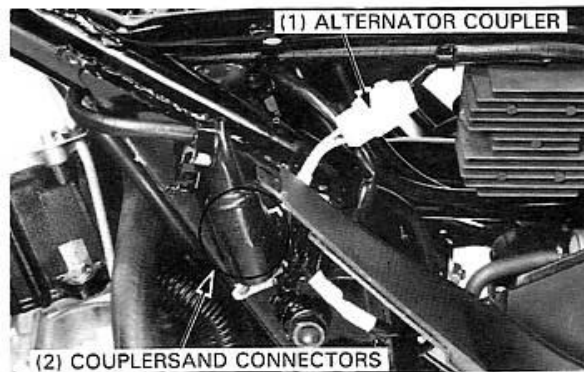

Disconnect the throttle cables from the carburetor.

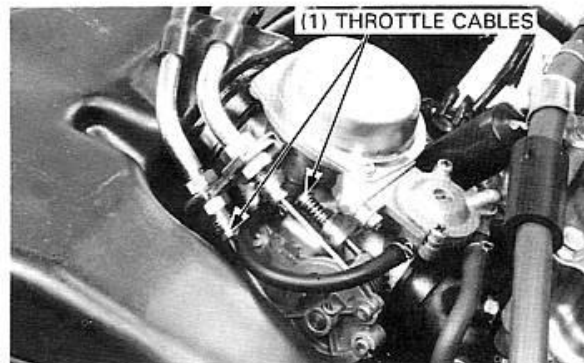

Disconnect the fuel tube and carburetor heater tube from the carburetor.

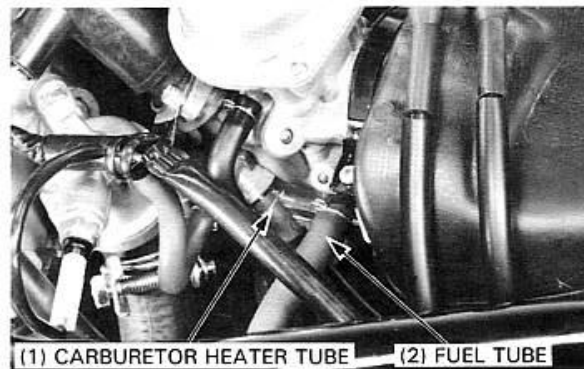

ENGINE REMOVAL/INSTALLATION

Disconnect the water hoses from the water pump and the thermostat housing.

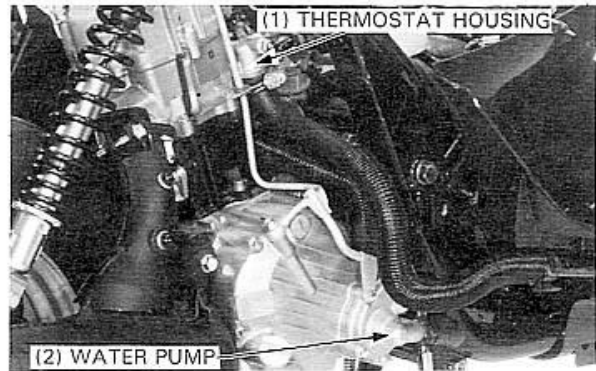

Remove the air cleaner breather tube from the air cleaner case. Remove the spark plug cap from the spark plug.

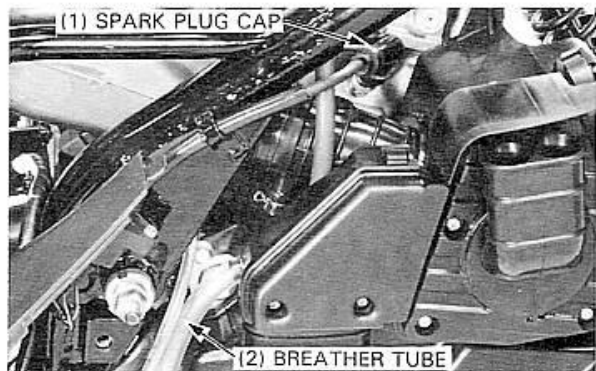

Remove the three bolts and rear brake cable clamps. Remove the rear brake adjusting nut and remove the rear brake cable from the brake arm.

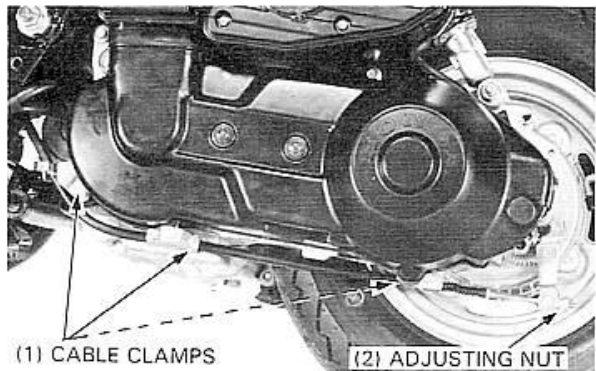

Remove the rear shock absorber upper mounting bolts.

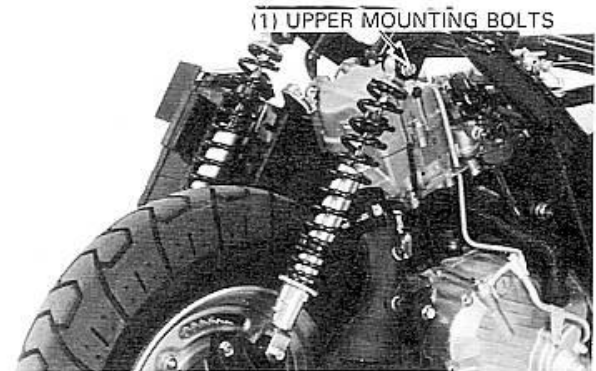

ENGINE REMOVAL/INSTALLATION

Remove the engine mounting nut and pull out the engine mounting bolt, then remove the engine.

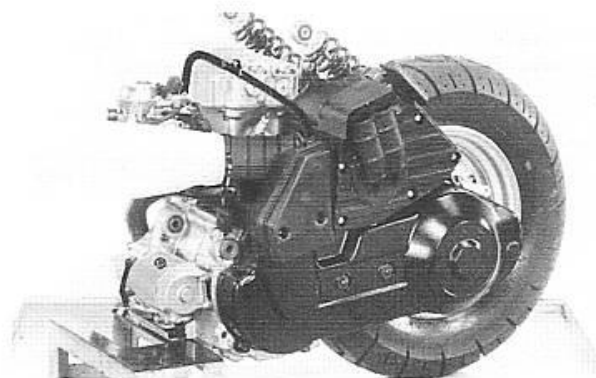
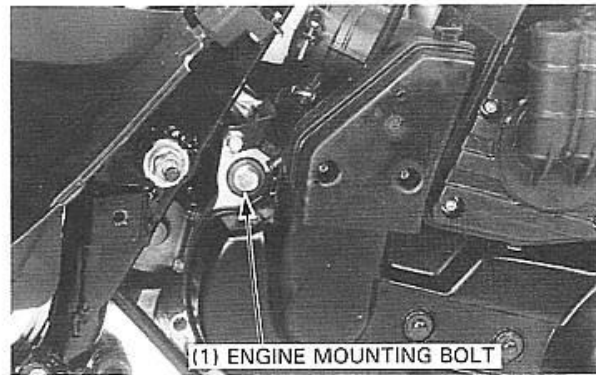

ENGINE HANGER

REMOVAL

Loosen and remove the engine hanger mounting nut. Hold the engine pivot collar C and loosen the pivot collar lock nut.

TOOL:

Pin spanner

07702-0020001

Loosen the pivot collar C and remove the engine hanger mounting bolt and engine hanger.

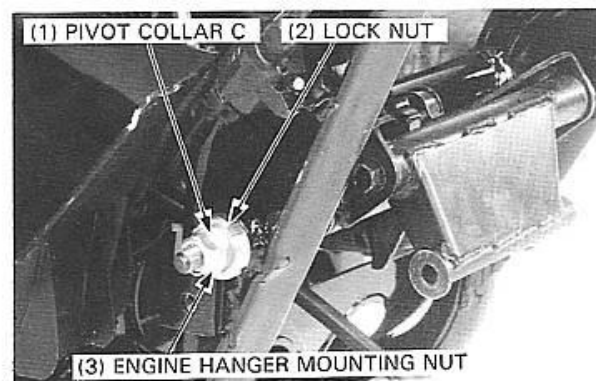

INSPECTION

Check the stopper rubber and damper rubber for damage.

Remove the bolts and nuts, and disassemble the engine hanger.

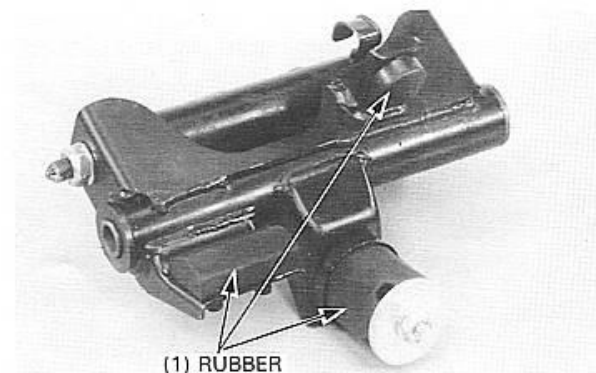

INSTALLATION

Install the stopper rubber and damper rubber to the engine hanger.

Install and tighten the engine hanger stopper rubber bolt.

TORQUE: 18–22 N·m (1.8–2.2 kg-m, 13–16 ft-lb)

Tighten the engine hanger tension arm nut and engine hanger nut.

TORQUE:

Engine hanger tension arm nut
24–30 N·m (2.4–3.0 kg-m, 17–22 ft-lb)

Engine hanger nut
55–70 N·m (5.5–7.0 kg-m, 40–51 ft-lb)

Loosely install the engine hanger to the frame.
Tighten the engine pivot collar C.

TORQUE: 25–35 N·m (2.5–3.5 kg-m, 18–25 ft-lb)

Hold the engine pivot collar C and tighten the pivot collar lock nut with the pin spanner.

TORQUE: 35–50 N·m (3.5–5.0 kg-m, 22–36 ft-lb)

TOOL:

Pin spanner 07702–0020001

Tighten the engine hanger mounting nut.

TORQUE: 70–90 N·m (7.0–9.0 kg-m, 51–65 ft-lb)

ENGINE INSTALLATION

Apply molybdenum disulfide grease to the new O-rings on the engine hanger inner bushings.

Install the engine hanger inner bushings.

Insert the engine mounting bolt and tighten the nut.

TORQUE: 40–55 N·m (4.0–5.5 kg-m, 29–40 ft-lb)

Install the rear shock absorber upper mounting bolts and tighten them.

TORQUE: 24–30 N·m (2.4–3.0 kg-m, 17–22 ft-lb)

Install the removed parts in the reverse order of removal.

NOTE

- Route the wires and cables properly (page 1-9).
- Fill the crankcase and final reduction to the proper level with the recommended oil (page 2-1).
- Fill the cooling system (page 12-3).
- Perform the following inspection and adjustment.
 - Throttle operation (page 3-4).
 - Rear brake pedal free play (page 3-11).

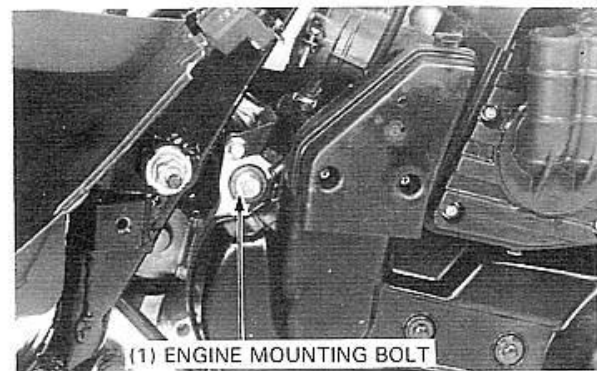
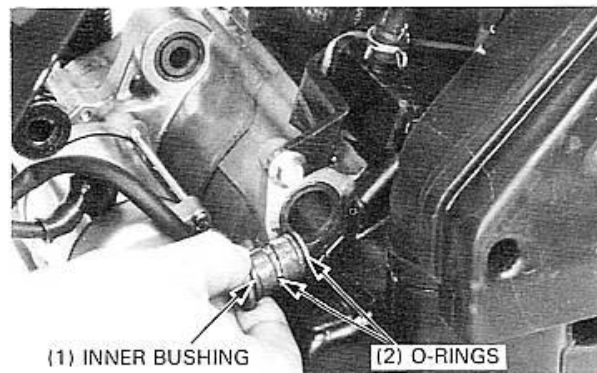
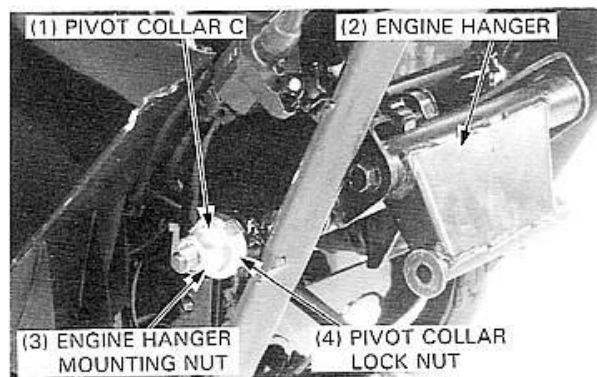

6. CYLINDER HEAD/VALVES

SERVICE INFORMATION	6-1	VALVE GUIDE REPLACEMENT	6-8
TROUBLESHOOTING	6-2	VALVE SEAT INSPECTION AND REFACING	6-8
CYLINDER HEAD COVER REMOVAL	6-3	CYLINDER HEAD ASSEMBLY	6-10
CYLINDER HEAD COVER DISASSEMBLY	6-3	CYLINDER HEAD INSTALLATION	6-11
CAMSHAFT REMOVAL	6-3	CAMSHAFT INSTALLATION	6-12
CYLINDER HEAD REMOVAL	6-4	CYLINDER HEAD COVER ASSEMBLY	6-13
CYLINDER HEAD DISASSEMBLY	6-6	CYLINDER HEAD COVER INSTALLATION	6-13

SERVICE INFORMATION

GENERAL

- This section covers maintenance of the cylinder head, valves, camshaft and rocker arms.

SPECIFICATIONS

ITEM		STANDARD mm (in)	SERVICE LIMIT mm (in)
Camshaft	Cam height	31.570–31.690 (1.2429–1.2476)	31.52 (1.241)
Rocker arm	Rocker arm I.D.	12.000–12.018 (0.4724–0.4731)	12.10 (0.476)
	Shaft O.D.	11.966–11.984 (0.4711–0.4718)	11.91 (0.469)
Valve	Valve stem O.D.	IN	4.975–4.990 (0.1959–0.1965)
		EX	4.955–4.970 (0.1951–0.1957)
	Valve guide I.D.	5.00–5.012 (0.1969–0.1973)	5.03 (0.198)
	Stem-to-guide clearance	IN	0.010–0.037 (0.0004–0.0015)
		EX	0.030–0.057 (0.0012–0.0022)
	Valve spring free length	Inner	30.7 (1.21)
		Outer	40.1 (1.58)
Valve seat width	1.1 (0.04)	1.8 (0.07)	
Cylinder head warpage		—	0.05 (0.002)

TORQUE VALUES

Cylinder head cover screw	3.5–5.0 N·m (0.35–0.50 kg·m, 2.5–3.6 ft·lb)	Apply a locking agent
Cylinder head cover bolt	8–12 N·m (0.8–1.2 kg·m, 6–9 ft·lb)	
Cylinder head cap nut	22–26 N·m (2.2–2.6 kg·m, 16–19 ft·lb)	
Camshaft holder bolt	8–12 N·m (0.8–1.2 kg·m, 6–9 ft·lb)	
Cam chain tensioner sealing bolt	8–12 N·m (0.8–1.2 kg·m, 6–9 ft·lb)	
Oil pipe bolt: 8 mm	8–12 N·m (0.8–1.2 kg·m, 6–9 ft·lb)	
Exhaust pipe stud bolt	7–11 N·m (0.7–1.1 kg·m, 5–8 ft·lb)	
Spark plug	15–20 N·m (1.5–2.0 kg·m, 11–15 ft·lb)	

CYLINDER HEAD/VALVES

TOOLS

Special

Valve guide reamer, 5.0 mm	07984—MA6000A or 07984—MA6000D
Valve guide remover	07942—MA60000

Common

Valve spring compressor	07757—0010000
Valve guide driver	07743—0020000 Not available in U.S.A.

TROUBLESHOOTING

Engine top-end problems usually affect engine performance. These can be diagnosed by a compression test, or by tracing noises with a sounding rod or stethoscope.

Low compression

- Valves
 - Incorrect valve adjustment
 - Burned or bent valves
 - Incorrect valve timing
 - Broken valve spring
- Cylinder head
 - Leaking or damaged head gasket
 - Warped or cracked cylinder head
- Cylinder and piston (Refer to Section 7)

Compression too high

- Excessive carbon build-up on piston or combustion chamber

Excessive noise

- Incorrect valve adjustment
- Sticking valve or broken valve spring
- Damaged or worn camshaft
- Loose or worn cam chain
- Worn or damaged cam chain tensioner
- Worn cam sprocket teeth
- Worn rocker arm and/or shaft

6-2

CYLINDER HEAD COVER REMOVAL

Remove the seat.

Remove the oil bolt and copper washers from the cylinder head cover.

Remove the air cleaner housing upper mounting bolt, five cylinder head cover bolts, air cleaner stay and cylinder head cover.

Remove the dowel pins from the cylinder head.

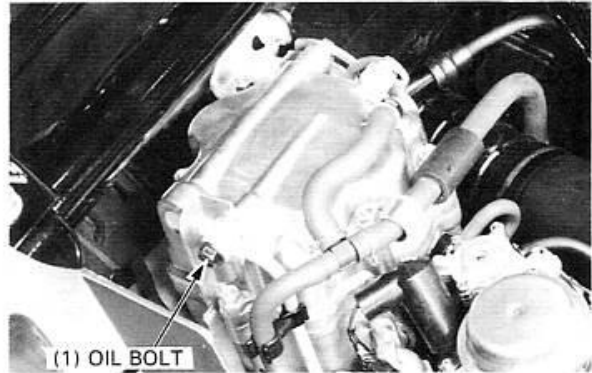

CYLINDER HEAD COVER DISASSEMBLY

Remove the O-ring from the cylinder head cover.

Remove the valve adjuster lock bolts.

Pull the rocker arm shafts and remove the rocker arms.

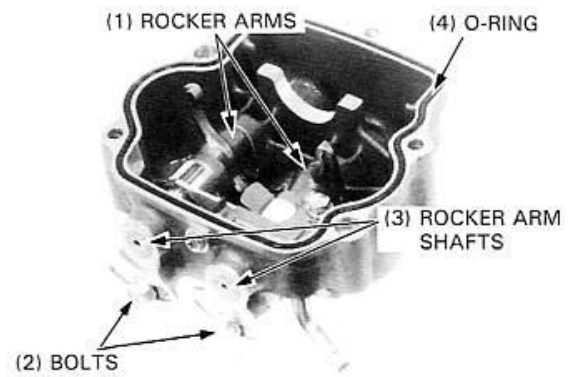

INSPECTION

ROCKER ARM

Inspect the rocker arm for wear or damage.

Measure the rocker arm I.D.

SERVICE LIMIT: 12.10 mm (0.476 in)

ROCKER ARM SHAFT

Inspect the rocker arm shaft for wear or damage.

Measure the rocker arm shaft O.D.

SERVICE LIMIT: 11.91 mm (0.469 in)

Inspect the O-ring for damage and replace if necessary.

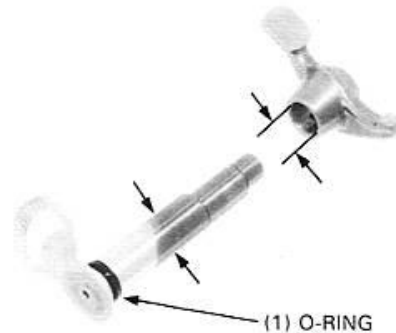

CAMSHAFT REMOVAL

Remove the exhaust muffler (page 15-2).

Remove the cam chain adjuster sealing bolt and spring.

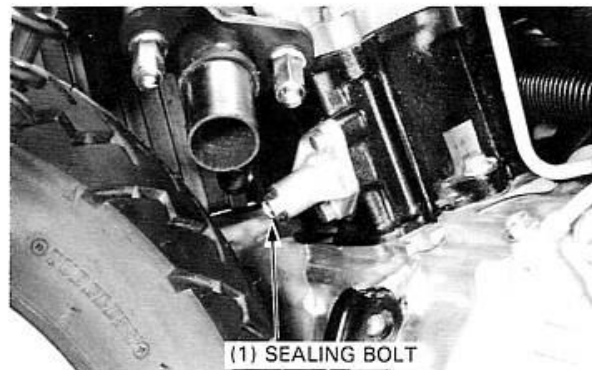

CYLINDER HEAD/VALVES

Remove the two camshaft bearing holder bolts and bearing holder.

NOTE

- Be careful not to drop the bolts into the crankcase.

Derail the cam chain from the cam sprocket teeth and remove the camshaft.

NOTE

- Suspend the cam chain with a piece of wire to keep it from falling into the crankcase.

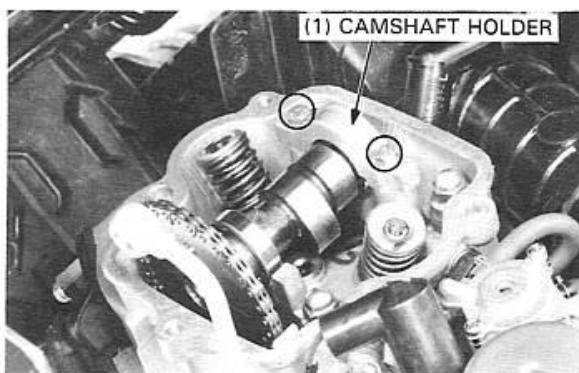

CAMSHAFT INSPECTION

Check each cam lobe for wear or damage.
Measure the intake and exhaust cam lobe height.

SERVICE LIMIT: 31.52 mm (1.241 in)



Turn the outer race of each camshaft bearing with your finger.
The bearings should turn smoothly and quietly.
Replace the camshaft assembly if the races do not turn smoothly or quietly.

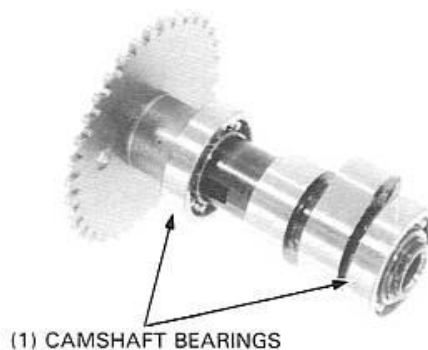

CYLINDER HEAD REMOVAL

Remove the air chamber and carburetor (page 4-3).

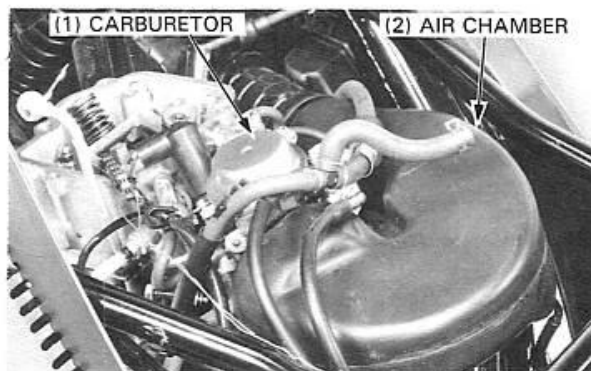

CYLINDER HEAD/VALVES

Drain the coolant (page 12-3).

Remove the thermostat housing bolt and thermostat housing from the cylinder head.

Remove the oil pipe stay mounting bolt and cylinder head base bolt.

Remove the four cylinder head cap nuts and four copper washers, and remove the cylinder head.

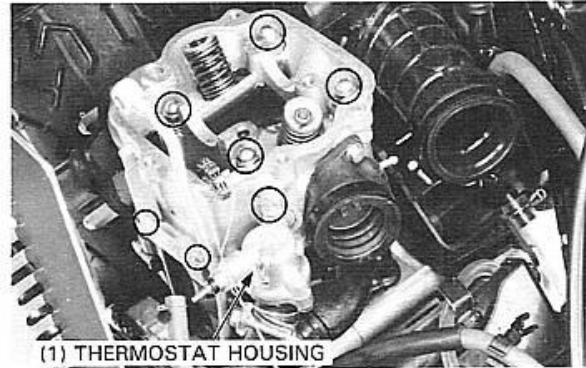

Remove the cylinder head gasket and dowel pins.

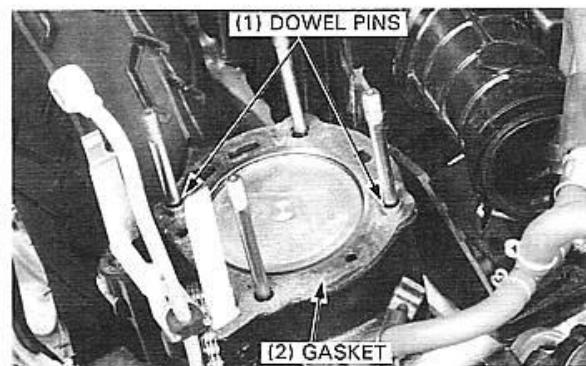

Remove the two exhaust pipe joint nuts and exhaust pipe from the cylinder head.

Remove the two bolts and carburetor insulator.

(1) EXHAUST PIPE

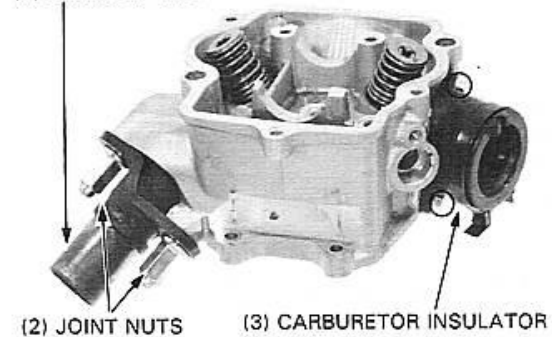

Remove all gasket material from the cylinder head mating surface.

NOTE

- Be careful not to drop the gasket material into cylinder.

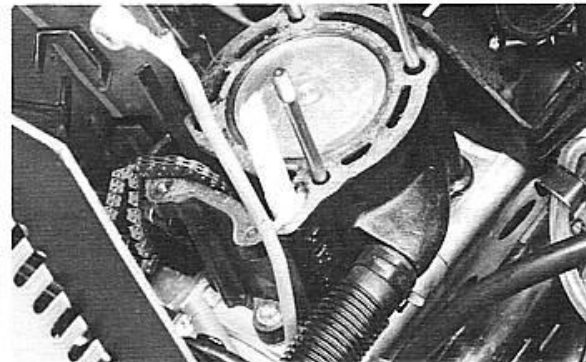

CYLINDER HEAD/VALVES

Check the camshaft bearing holder for wear or damage.

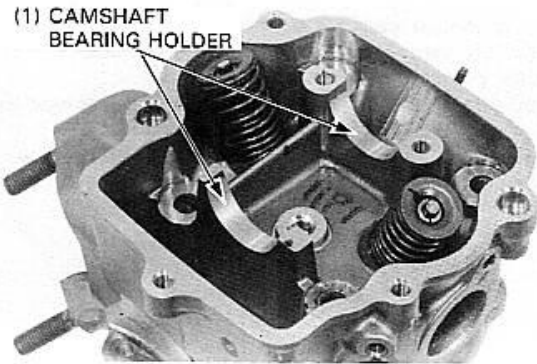

CYLINDER HEAD DISASSEMBLY

Compress the valve spring and remove the valve cotters, retainers, springs, spring seats and valves.

TOOL:

Valve spring compressor 07757-0010000

CAUTION

- To prevent loss of tension, do not compress the valve springs more than necessary to remove the cotters.

NOTE

- Mark all disassembled parts to ensure correct reassembly.

Remove the valve stem seals.

Remove carbon deposits from the combustion chamber. Clean off any gasket material from the cylinder head gasket surface.

NOTE

- Avoid damaging the gasket surfaces.
- Gaskets will come off easier if soaked in solvent.

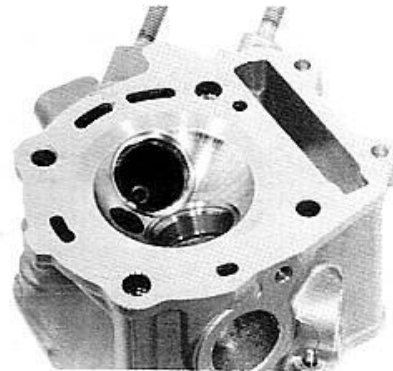
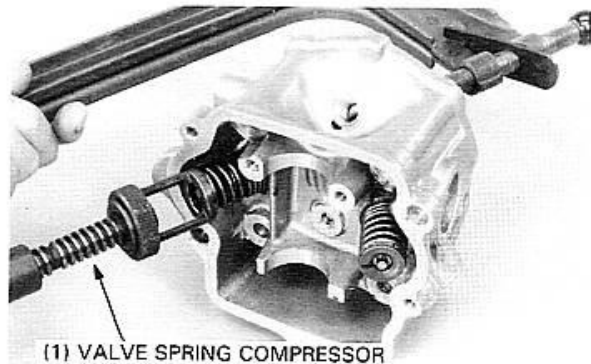

INSPECTION

CYLINDER HEAD

Check the spark plug hole and valve areas for cracks. Check the cylinder head for warpage with a straight edge and feeler gauge.

SERVICE LIMIT: 0.05 mm (0.002 in)

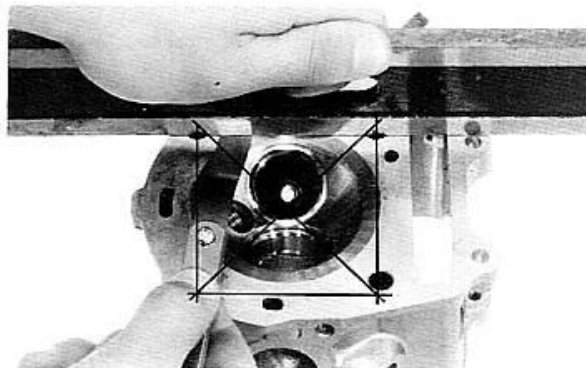

VALVE SPRING FREE LENGTH

Measure the free length of the inner and outer valve springs.

SERVICE LIMITS:

INNER (IN, EX): 29.5 mm (1.16 in)

OUTER (IN, EX): 38.4 mm (1.50 in)

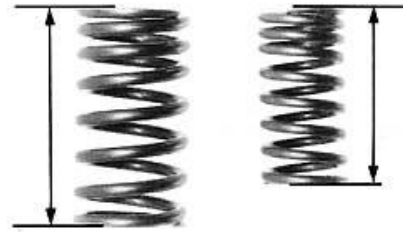

VALVE STEM

Inspect each valve for bending, burning, or abnormal stem wear.

Check valve movement in the guide and measure and record each valve stem O.D.

SERVICE LIMITS:

IN : 4.90 mm (0.193 in)

EX: 4.90 mm (0.193 in)

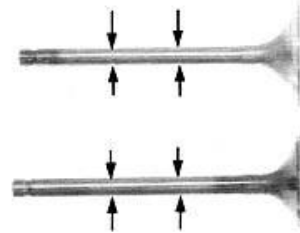

VALVE GUIDES

NOTE

- Ream the guides to remove any carbon build-up before checking clearances.

TOOL:

Valve guide reamer

07984—MA6000A or
07984—MA6000D

Measure and record each valve guide I.D. using a ball gauge or inside micrometer.

SERVICE LIMIT: 5.03 mm (0.198 in)

Subtract each valve stem O.D. from the corresponding guide I.D. to obtain the stem-to-guide clearance.

SERVICE LIMITS:

IN : 0.08 mm (0.003 in)

EX: 0.10 mm (0.004 in)

NOTE

- If the stem-to-guide clearance exceeds the service limits, determine if a new guide with standard dimensions would bring the clearance within tolerance. If so, replace any guide as necessary and ream to fit.

If the stem-to-guide clearance exceeds the service limits with new guides, replace the valves also.

NOTE

- Reface the valve seats whenever the valve guides are replaced (page 6-8).

(1) VALVE GUIDE REAMER

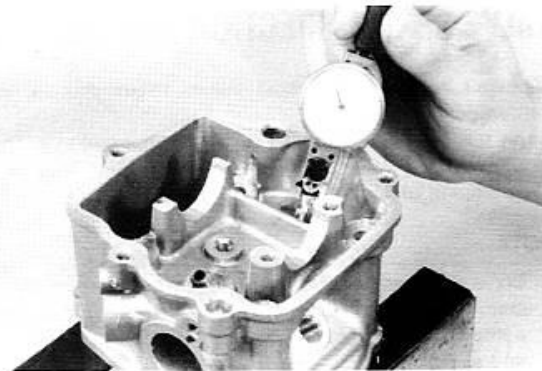
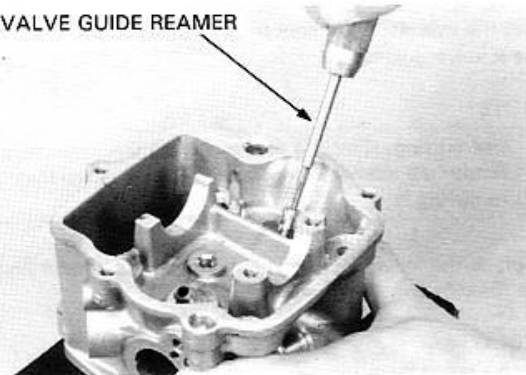

CYLINDER HEAD/VALVES

VALVE GUIDE REPLACEMENT

Heat the cylinder head to 100° – 150°C (212° – 300°F) with a hot plate or oven.

CAUTION

- Do not use a torch to heat the cylinder head; it may cause warping.
- To avoid burns, wear heavy gloves when handling the heated cylinder head.

Support the cylinder head and drive out the old guides from the combustion chamber side of the cylinder head.

TOOL:

Valve guide remover 07942—MA60000

NOTE

- After driving the guides out, check them for damage.
- Cylinder head heat should still be at 100° – 150°C (212° – 300°F) for installation of the new guide.

Adjust the valve guide driver so that the valve guide height is 12 mm (0.47 in).

Drive the new guides into the cylinder head from the rocker arm side.

TOOL:

Valve guide driver 07743—0020000
Not available in U.S.A.

Let the cylinder head cool to room temperature and ream the new valve guides.

NOTE

- Use cutting oil on the reamer during this operation.
- Rotate the reamer in the same direction when inserting and removing it.

Reface the valve seat and clean the cylinder head thoroughly to remove any metal particles.

TOOL:

Valve guide reamer 07984—MA6000A

VALVE SEAT INSPECTION AND REFACING

Clean all intake and exhaust valves thoroughly to remove carbon deposits.

Apply a light coating of valve lapping compound to each valve face. Lap each valve and seat using a rubber hose or other hand-lapping tool.

NOTE

- Do not allow the compound to enter between the valve stem and guide. After lapping, wash out the compound completely and apply a coat of engine oil to the valve face and seat.

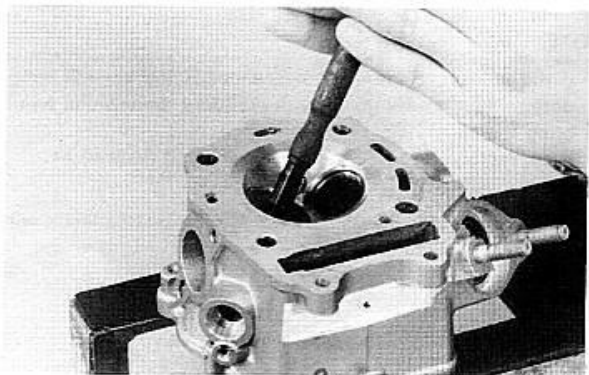
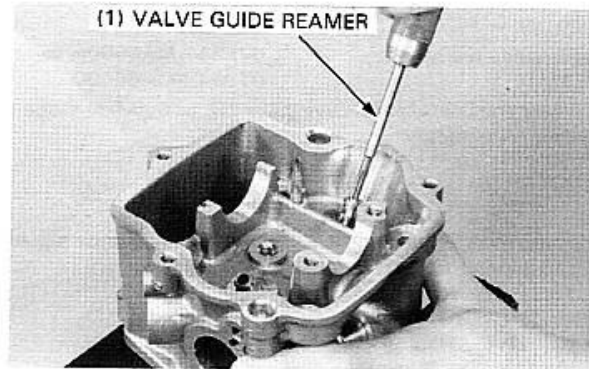
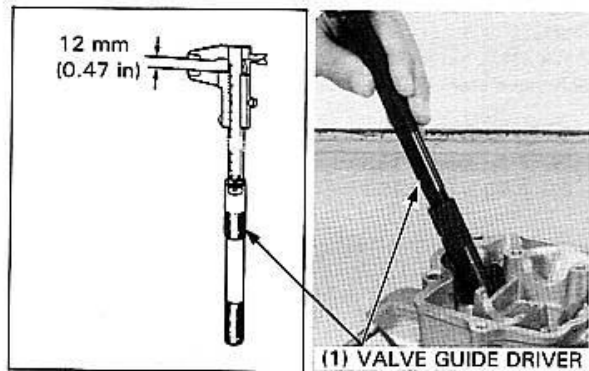
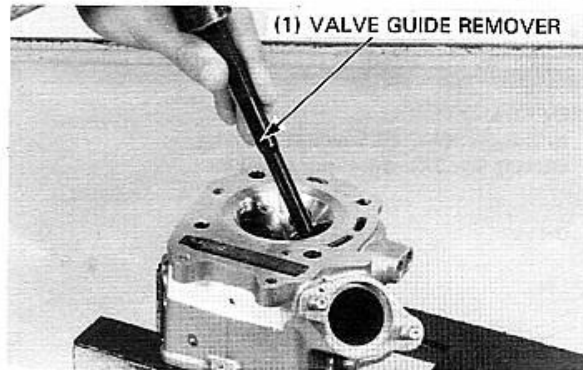

Remove the valve and inspect the face.

CAUTION

- *The valves cannot be ground. If the valve face is burned, worn unevenly, or if it contacts the seat improperly, the valve must be replaced.*

Inspect the valve seat.

If the seat is too wide, too narrow, or has low spots, the seat must be ground.

SEAT WIDTH:

Service limit: 1.8 mm (0.07 in)

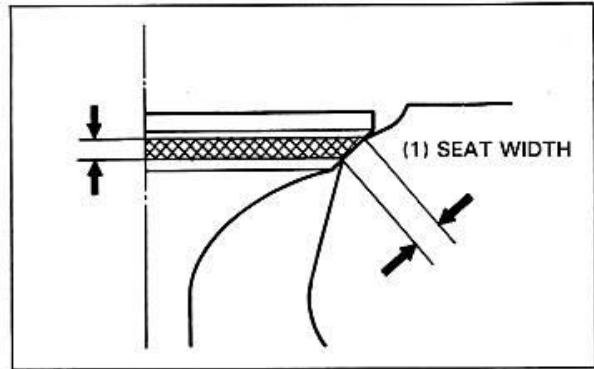

VALVE SEAT GRINDING

Using a 45-degree cutter, remove any roughness or irregularities from the seat.

NOTE

- Reface the seat with a 45 degree cutter when the valve guide is replaced.

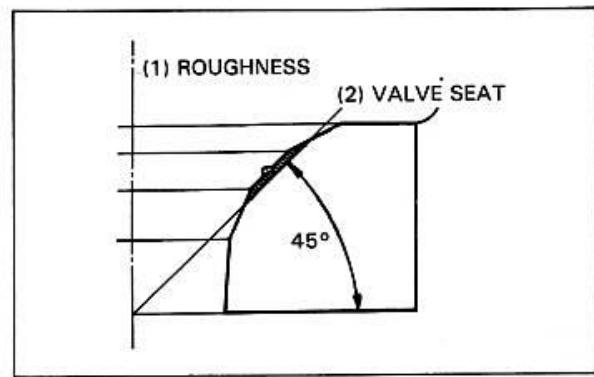

Using a 32-degree cutter, remove 1/4 of the existing valve seat material.

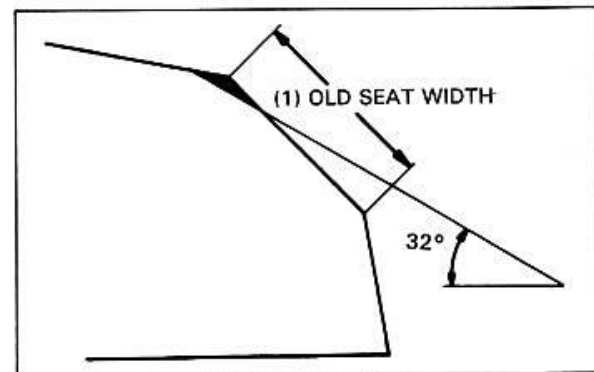

Using a 60-degree cutter, remove the bottom 1/4 of the old seat.

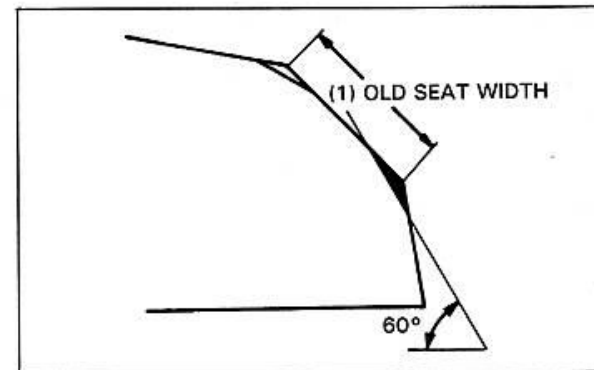

CYLINDER HEAD/VALVES

Using a 45-degree finish cutter, cut the seat to the proper width.

NOTE

- Make sure that all pitting and irregularities are removed. Refinish if necessary.

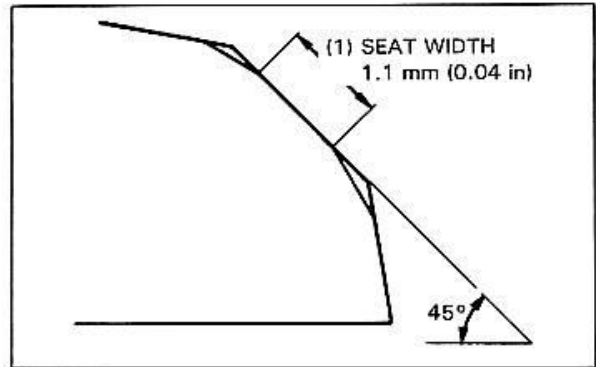

NOTE

- The location of the valve seat in relation to the valve face is very important for good sealing and maximum valve service.

Apply a thin coating of Prussian Blue to the valve seat. Press the valve through the valve guide and onto the seat to make a clear pattern. Remove to inspect the valve. If the contact area is too high on the valve, the seat must be lowered using a 32-degree flat cutter. Refinish the seat to the correct width using a 45-degree finish cutter.

If the contact area is too low on the valve, the seat must be raised using a 60 degree inner cutter. Refinish the seat to the correct width, using a 45 degree finish cutter.

After cutting the seat, apply lapping compound to the valve face, and lap the valve using light pressure. After lapping, wash all residual compound off the cylinder head, valve, and guide.

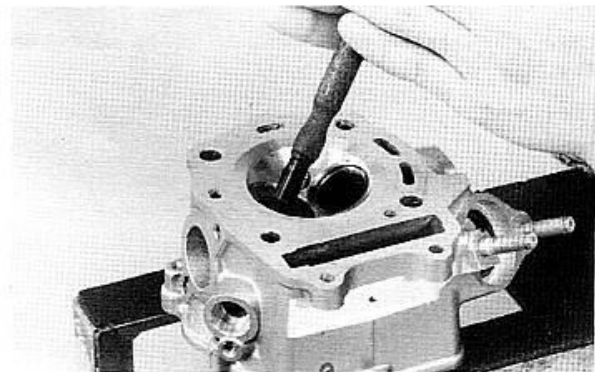
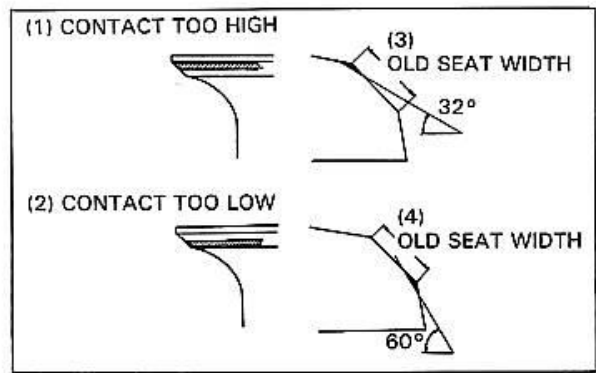

CYLINDER HEAD ASSEMBLY

Lubricate each valve stem with oil, then insert the valves into the valve guides.

Install new valve stem seals.

Install the valve spring seat, springs and retainers.

The spring's tightly wound coils should face in toward the combustion chamber.

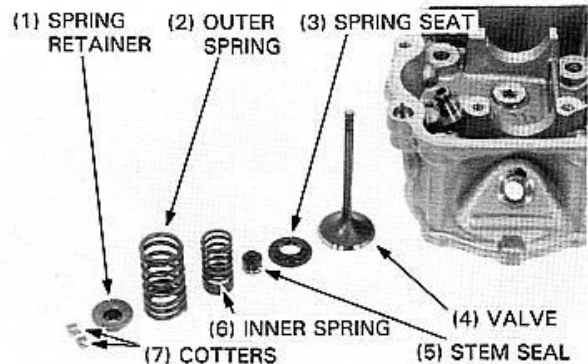

CYLINDER HEAD/VALVES

Compress the valve springs using the valve spring compressor, then install the valve cotters.

CAUTION

- To prevent loss of tension, do not compress the valve spring more than necessary.

TOOL:

Valve spring compressor 07757-0010000

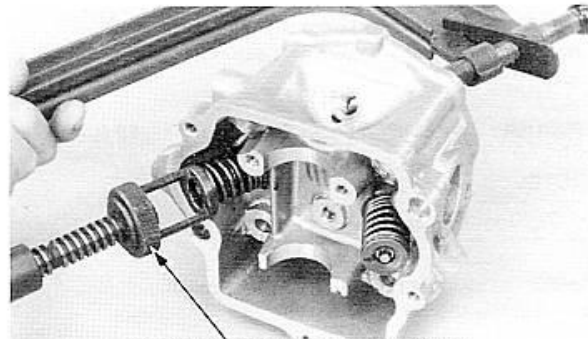

(1) VALVE SPRING COMPRESSOR

Tap the valve stems gently with a plastic hammer as shown to firmly seat the cotters.

CAUTION

- Support the cylinder head above the working bench surface to prevent possible valve damage.

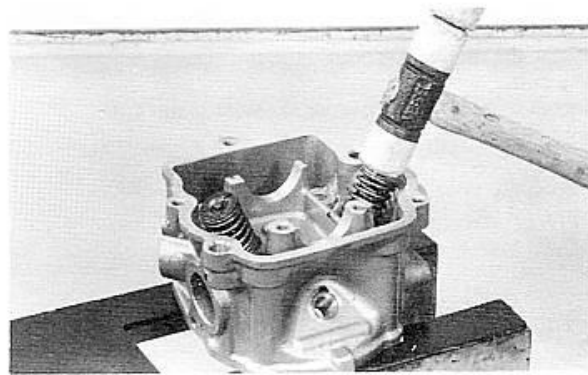

Install the exhaust pipe joint and tighten the joint nuts.

Install the carburetor insulator with two bolts and tighten the bolts.

(1) EXHAUST PIPE

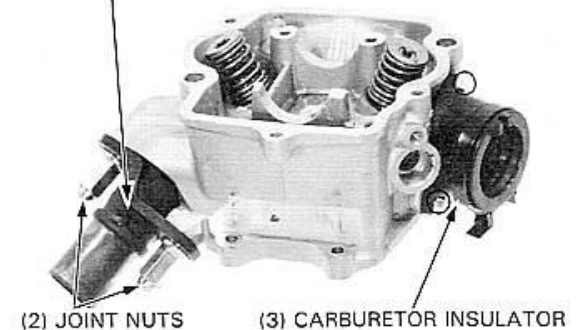

(2) JOINT NUTS

(3) CARBURETOR INSULATOR

CYLINDER HEAD INSTALLATION

Install the dowel pins and a new gasket onto the cylinder.

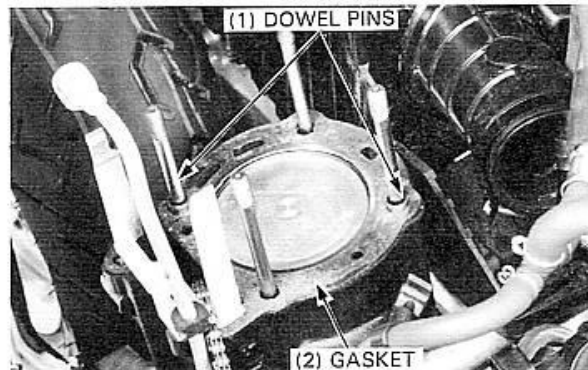

(1) DOWEL PINS

(2) GASKET

CYLINDER HEAD/VALVES

Install the cylinder head onto the cylinder.
Install four copper washers and cap nuts, and tighten the cap nuts.

TORQUE: 22–26 N·m (2.2–2.6 kg-m, 16–19 ft-lb)

NOTE

- Tighten the cap nuts in a crisscross pattern in 2-3 steps.

Install the cylinder base bolt, oil pipe stay and oil pipe stay bolt, and tighten the bolts.

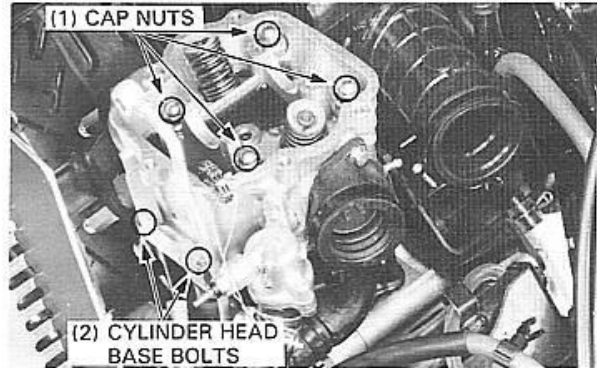

Install a new O-ring onto the thermostat housing.
Install the thermostat housing to the cylinder head and tighten the bolt.
Install the carburetor and air chamber (page 4-9).

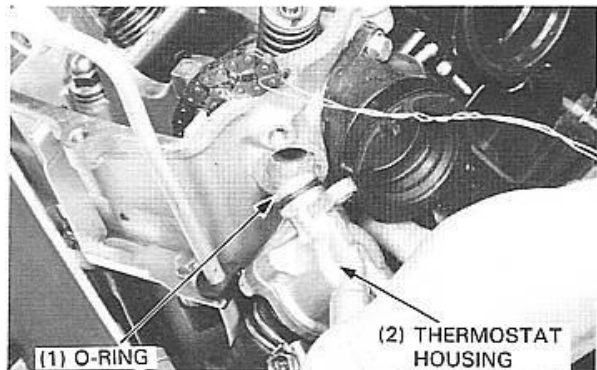

CAMSHAFT INSTALLATION

Push the cam chain adjuster push rod back into the adjuster body by pressing the tab down.

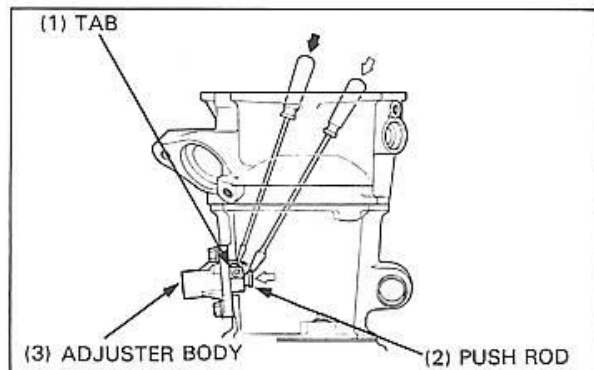

Remove the timing hole cap from the right crankcase cover.
Remove the left crankcase cover (page 8-3).
Turn the drive pulley counterclockwise and align the "T" mark on the flywheel with the index mark on the right crankcase cover.

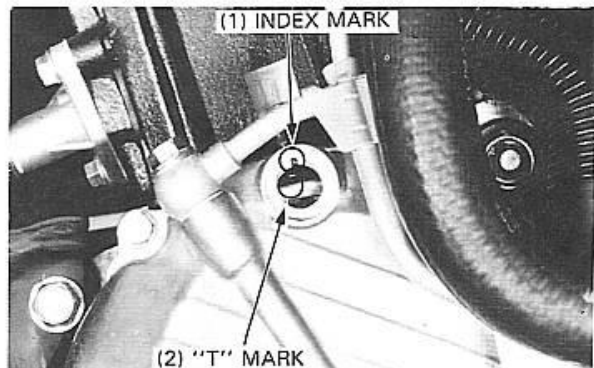

Position the intake and exhaust cam lobes down.
Align the index line on the cam sprocket with the cylinder head upper surface and install the cam chain over the cam sprocket. Install the camshaft holder onto the cylinder head and tighten the two bolts.

TORQUE: 8–12 N·m (0.8–1.2 kg·m, 6–9 ft·lb)

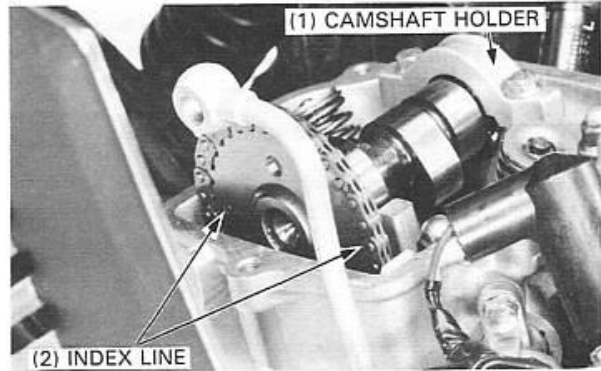

Install the camchain adjuster spring and sealing bolt, and tighten the sealing bolt.

TORQUE: 8–12 N·m (0.8–1.2 kg·m, 6–9 ft·lb)

Install the left crankcase cover (page 8-3).
Install the timing hole cap to the right rear cover.
Install the exhaust muffler (page 15-2).

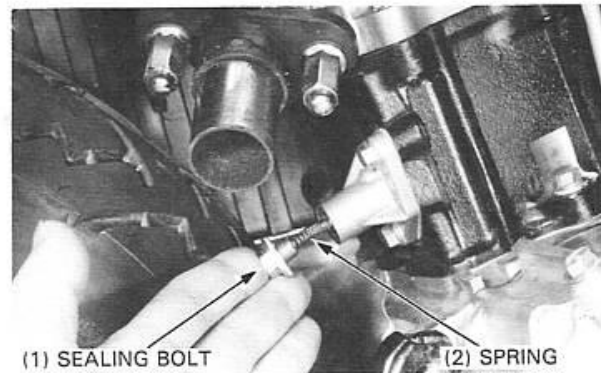

CYLINDER HEAD COVER ASSEMBLY

Install new O-rings onto the rocker arm shafts.
Apply clean engine oil to the rocker arms and shafts and install them into the cylinder head cover.
Loosely install the valve adjuster lock bolts.
Install the rubber seal into the groove in the cylinder head cover.

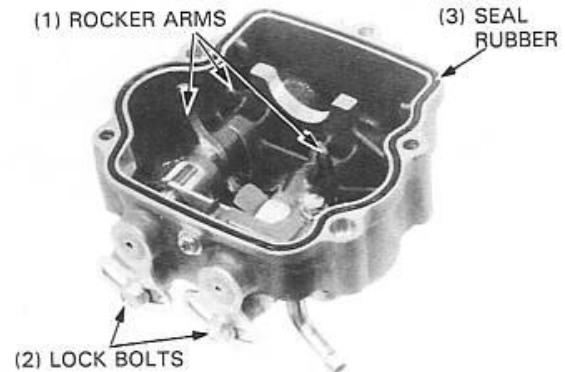

CYLINDER HEAD COVER INSTALLATION

Fill the oil pocket in the cylinder head with clean engine oil to provide initial lubrication for the camshaft when the engine is started.
Install two dowel pins onto the cylinder head.
Install the cylinder head cover.

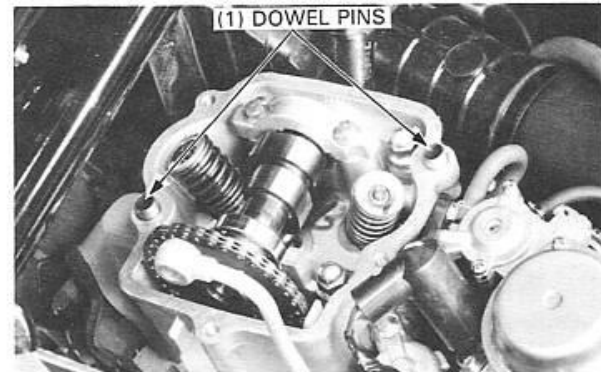

CYLINDER HEAD/VALVES

Install the air cleaner stay and five 6 mm flange bolts.
Tighten the 6 mm flange bolts in crisscross pattern in two or more steps.

TORQUE: 8–12 N·m (0.8–1.2 kg-m, 6–9 ft-lb)

Tighten the air cleaner housing to the stay with the bolt.
Install the copper washers and oil pipe bolt, and tighten the oil pipe bolt.

TORQUE: 8–12 N·m (0.8–1.2 kg-m, 6–9 ft-lb)

Adjust the valve clearance (page 3-6).
Install the seat.

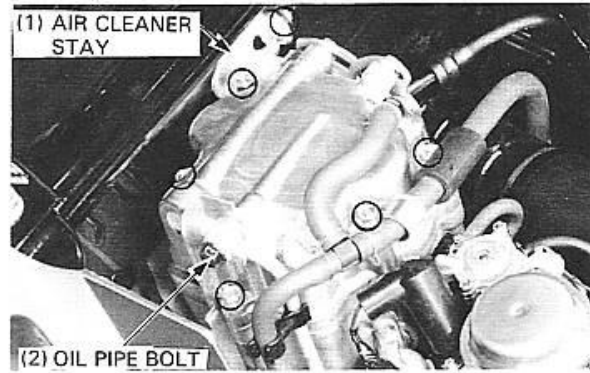

6-14

End of Chapter 6

CYLINDER/PISTON

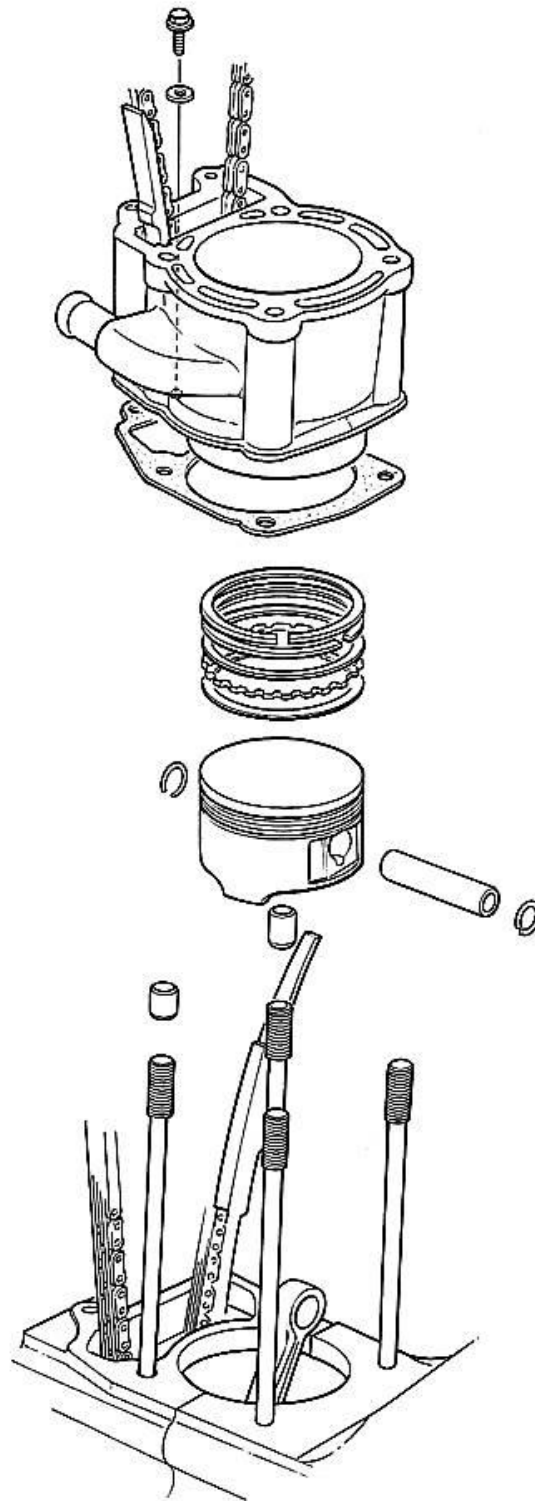

7. CYLINDER/PISTON

SERVICE INFORMATION	7-1	PISTON REMOVAL	7-3
TROUBLESHOOTING	7-1	PISTON INSTALLATION	7-6
CYLINDER REMOVAL	7-2	CYLINDER INSTALLATION	7-7

SERVICE INFORMATION

GENERAL

- The cylinder and piston can be serviced with the engine in the frame.

SPECIFICATIONS

ITEM		STANDARD mm (in)	SERVICE LIMIT mm (in)	
Cylinder	I.D.	72.000–72.010 (2.8346–2.8350)	72.10 (2.839)	
	Warpage	—	0.05 (0.002)	
	Taper	—	0.05 (0.002)	
	Out-of-round	—	0.05 (0.002)	
Piston, Piston ring	Ring-to-groove clearance	Top	0.015–0.050 (0.0006–0.0020)	0.09 (0.004)
		Second	0.015–0.050 (0.0006–0.0020)	0.09 (0.004)
	Ring end gap	Top	0.15–0.35 (0.006–0.014)	0.50 (0.020)
		Second	0.15–0.35 (0.006–0.014)	0.50 (0.020)
		Oil (Side rail)	0.2–0.7 (0.01–0.03)	—
	Piston O.D.	71.970–71.990 (2.8338–2.8342)	71.90 (2.831)	
	Piston-to-cylinder clearance	0.010–0.040 (0.0004–0.0016)	0.10 (0.004)	
Piston pin bore	17.002–17.008 (0.6694–0.6696)	17.04 (0.671)		
Piston pin O.D.	16.994–17.000 (0.6691–0.6693)	16.96 (0.668)		
Piston-to-piston pin clearance	0.002–0.014 (0.0001–0.0006)	0.02 (0.001)		
Connecting rod small end I.D.	17.016–17.034 (0.6699–0.6706)	17.06 (0.672)		

TORQUE VALUE

Camchain adjuster base bolt 8–12 N·m (0.8–1.2 kg·m, 6–9 ft·lb)

TROUBLESHOOTING

Low compression or uneven compression

- Worn cylinder or piston rings

Excessive smoke

- Worn cylinder, piston or piston rings
- Improperly installed piston rings
- Damaged piston or cylinder

Overheating

- Excessive carbon build-up on piston head
- Blocked or restricted flow of coolant
- Sticking thermostat

Knocking or abnormal noise

- Worn piston and cylinder
- Excessive carbon build-up on piston head

CYLINDER/PISTON

CYLINDER REMOVAL

Remove the cylinder head (section 6).

Disconnect the water hose from the cylinder.

Remove the cam chain guide.

Remove the cylinder base bolt and cylinder.

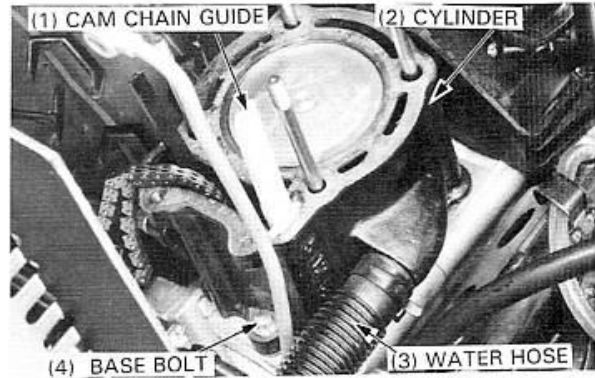

Remove the cylinder gasket and dowel pins.

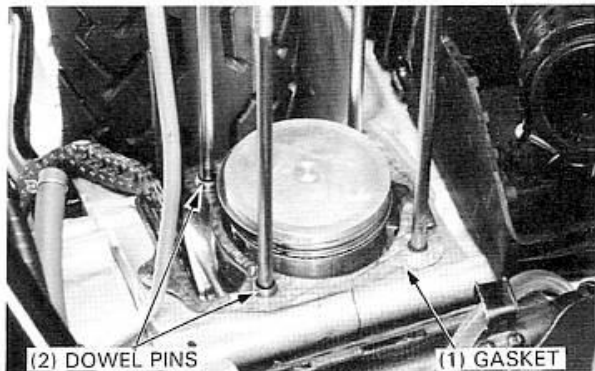

Place rags in the crankcase openings.
Clean off any gasket material from the cylinder surface of the crankcase.

NOTE

- Gasket material will come off easier if it is soaked in solvent.

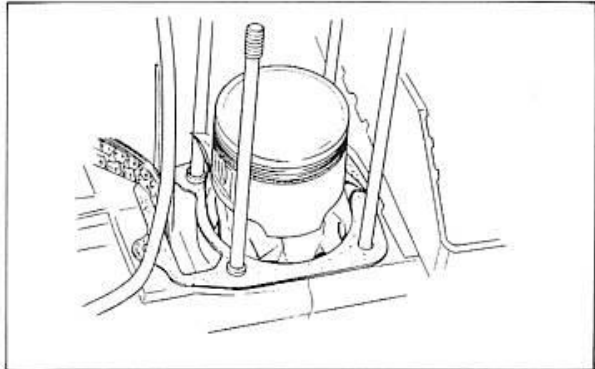

Remove the cam chain adjuster base and gasket from the cylinder.



Clean any gasket material from the cylinder surface.

NOTE

- Gasket material will come off easier if it is soaked in solvent.

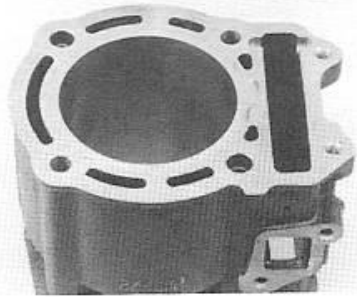

PISTON REMOVAL

Place clean shop towels in the crankcase opening to keep the piston pin clips, or other parts from falling into the crankcase. Remove the piston pin clips with pliers.

Pull the piston pin out of the piston and remove the piston.

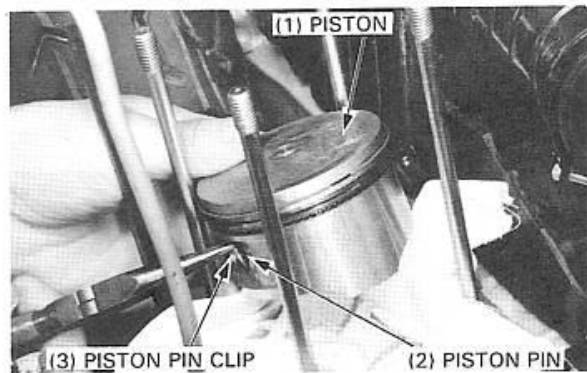

PISTON, PISTON PIN AND PISTON RING INSPECTION

Measure the piston pin hole I.D.

SERVICE LIMIT: 17.04 mm (0.6709 in)

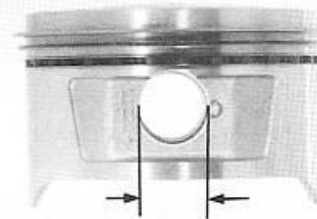

Measure piston pin O.D.

SERVICE LIMIT: 16.96 mm (0.668 in)

Calculate the piston pin-to-piston clearance.

SERVICE LIMIT: 0.02 mm (0.001 in)



CYLINDER/PISTON

Measure the piston ring-to-groove clearance.

SERVICE LIMITS: TOP 0.09 mm (0.004 in)
2nd 0.09 mm (0.004 in)

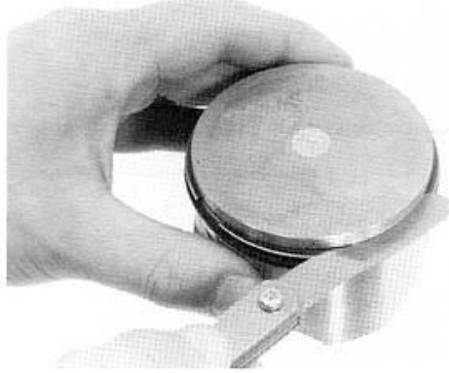

Measure the connecting rod small end I.D.

SERVICE LIMIT: 17.06 mm (0.672 in)

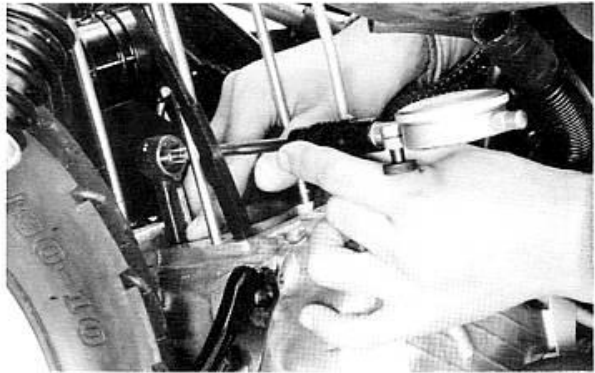

Remove the piston rings.
Inspect the piston for damage and the ring grooves for wear.

CAUTION

- *Piston rings are easily broken; take care not to damage them during removal.*



Insert each piston ring into the cylinder 20 mm (0.75 in) in from the bottom. To ensure that it's square in the bore, use a piston to push it in.

Measure the ring end gap.

SERVICE LIMITS: TOP 0.50 mm (0.020 in)
2nd 0.50 mm (0.020 in)

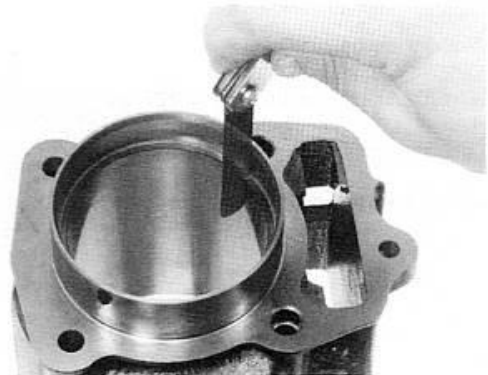

Measure and record the piston O.D. at a point 10 mm (0.4 in) from the bottom, and 90° to the piston pin bore.

SERVICE LIMIT: 71.90 mm (2.831 in)

Compare this measurement against the service limit and calculate piston-to-cylinder clearance.



CYLINDER INSPECTION

Inspect the cylinder walls for scratches and wear. Measure and record the cylinder I.D. at three levels in both X and Y axis. Take the maximum reading to determine the cylinder wear.

SERVICE LIMIT: 72.10 mm (2.839 in)

Calculate the piston-to-cylinder clearance. Take the maximum reading to determine the clearance.

SERVICE LIMIT: 0.10 mm (0.004 in)

Calculate the cylinder for taper at three levels in an X and Y axis. Take the maximum reading to determine the taper.

SERVICE LIMIT: 0.05 mm (0.002 in)

Calculate the cylinder for out-of-round at three levels in an X and Y axis. Take the maximum reading to determine the out-of-round.

SERVICE LIMIT: 0.05 mm (0.002 in)

The cylinder must be rebored and an oversize piston fitted if the service limits are exceeded.

The following oversize pistons are available:
 0.25 mm (0.010 in), 0.50 mm (0.020 in) and
 0.75 mm (0.030 in)

The cylinder must be rebored so that the clearance to an oversize piston is 0.010–0.040 mm (0.0004–0.0016 in)

Inspect the top of the cylinder for warpage.

SERVICE LIMIT: 0.05 mm (0.002 in)

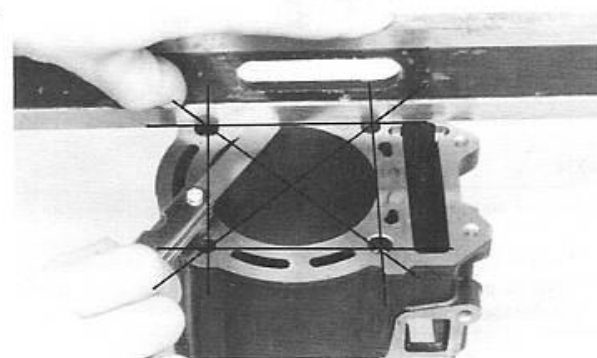
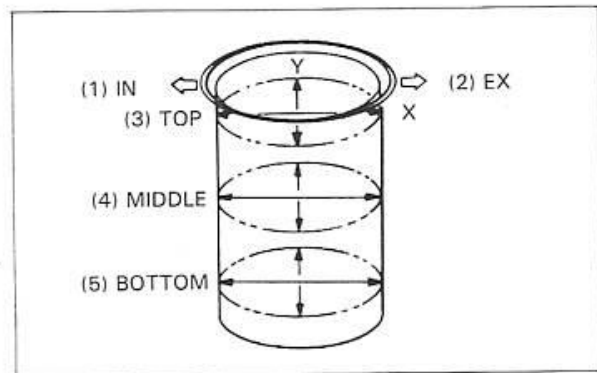
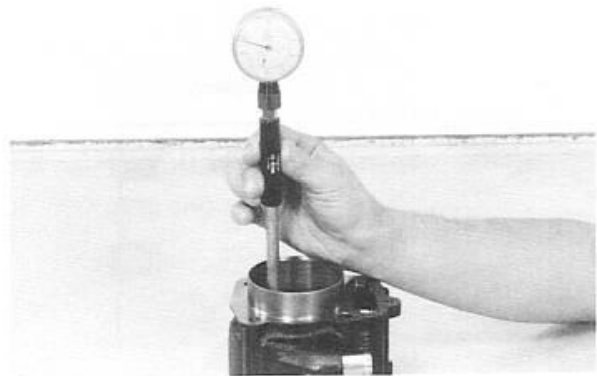

CYLINDER/PISTON

PISTON RING INSTALLATION

Clean the piston head, ring lands, and skirts.
Carefully install the piston rings onto the piston.
Stagger the ring end gaps as shown.

NOTE

- Be careful not to damage the piston and piston rings during assembly.
- All rings should be installed with the markings facing up.
- After installing the rings they should rotate freely, without sticking.

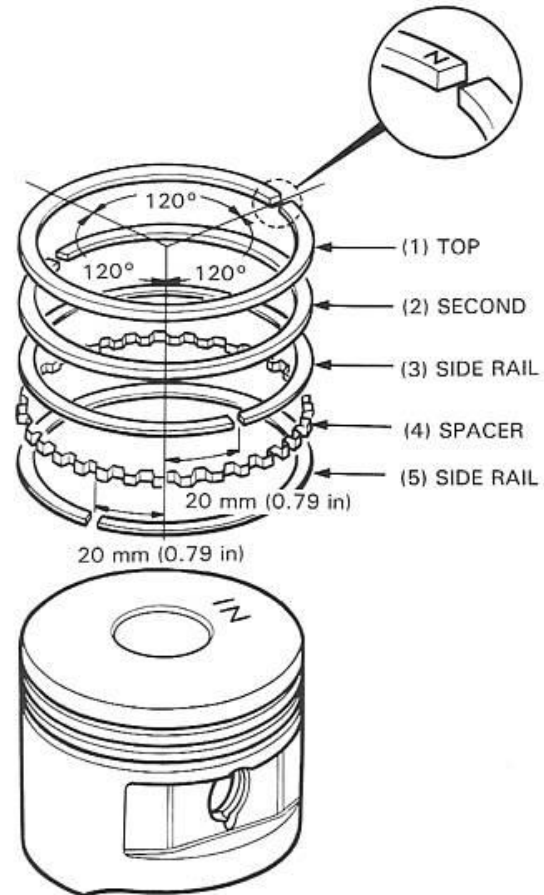
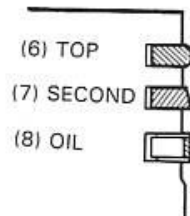

PISTON INSTALLATION

Install the piston and piston pin. Position the piston "IN" mark on the intake valve side.
Install a new piston pin clips.

NOTE

- Do not align the piston pin clip end gap with the piston cut-out.
- Place a shop towel around the piston skirt and in the crankcase to prevent the piston pin clips from falling into the crankcase.

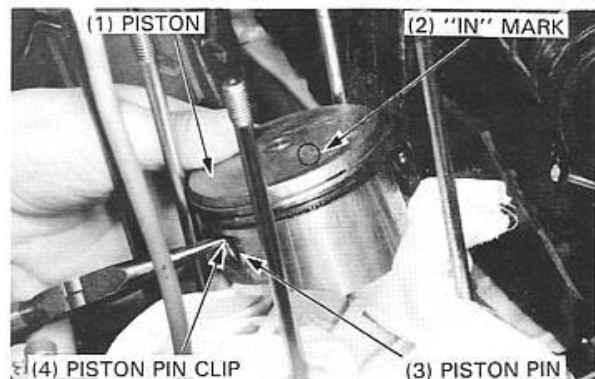

CYLINDER INSTALLATION

Install the cam chain adjuster base onto the cylinder with a new gasket.
Tighten the two adjuster base bolts.

TORQUE: 8–12 N·m (0.8–1.2 kg·m, 6–9 ft·lb)

See description below for cylinder marking information.

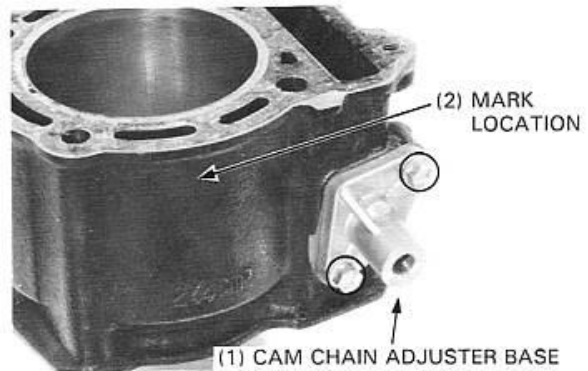

Install the two dowel pins and a new cylinder gasket of the type specified below.



NOTE

- Cylinders with no letter marking must be installed with a 1.00 mm metal cylinder base gasket.
Cylinders marked "A" must be installed with a 0.25 mm metal cylinder base gasket.

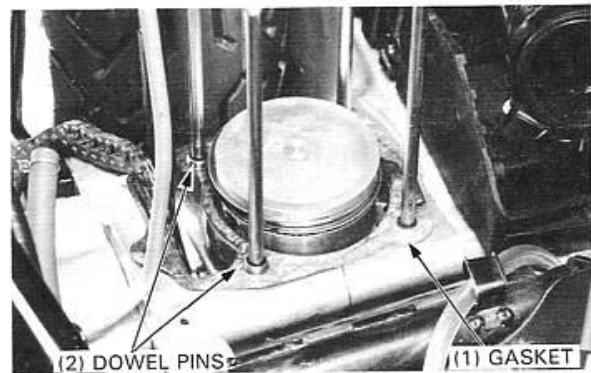

CAUTION

- *Camshaft damage may result if an "A" marked cylinder and a 1.00 mm cylinder base gasket are installed.*

Coat the cylinder bore, piston and piston rings with fresh engine oil.
Carefully lower the cylinder over the piston by compressing the piston rings, one at a time.

CAUTION

- *Do not force the cylinder over a ring; you may damage the piston and piston rings.*

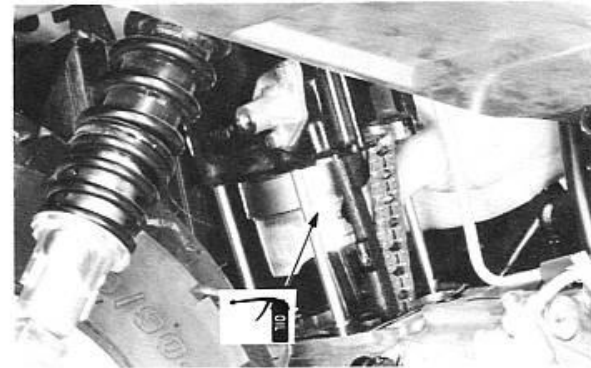

Loosely install the cylinder base bolt and seal washer.
Install the water hose to the cylinder.
Install the cam chain guide.

NOTE

- Push the guide in until it bottoms in the crankcase guide hole.

Install the cylinder head (Section 6).
Tighten the cylinder base bolt.

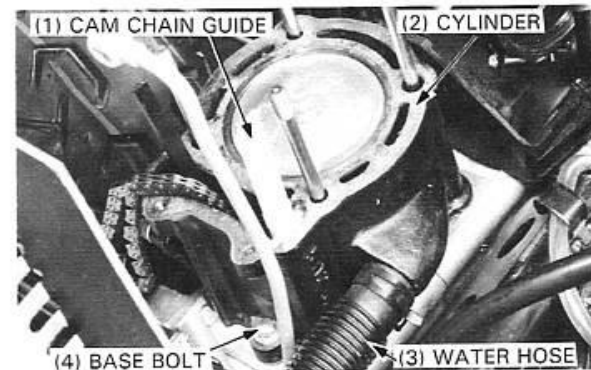

DRIVE PULLEY/CLUTCH/DRIVEN PULLEY

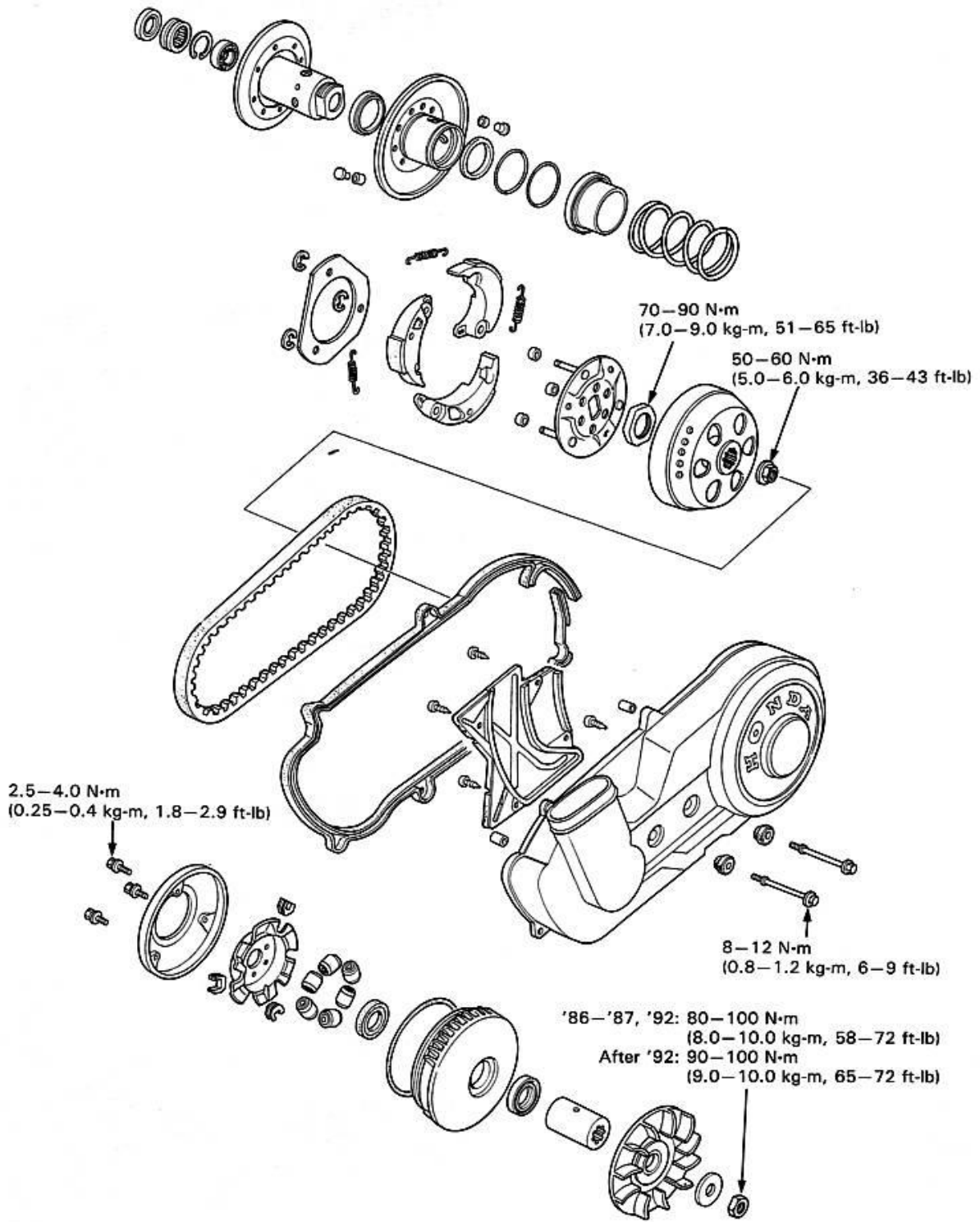

8. DRIVE PULLEY/CLUTCH/DRIVEN PULLEY

SERVICE INFORMATION	8-1	DRIVE BELT	8-3
TROUBLESHOOTING	8-2	DRIVE PULLEY	8-4
LEFT CRANKCASE COVER	8-3	CLUTCH/DRIVEN PULLEY	8-8

SERVICE INFORMATION

GENERAL

- The drive pulley, clutch and driven pulley can be serviced with the engine installed.
- Avoid getting grease and oil on the drive belt and pulley faces.

SPECIFICATIONS

ITEM	STANDARD mm (in)	SERVICE LIMIT mm (in)
Movable drive face bushing I.D.	27.000–27.021 (1.0630–1.0638)	27.06 (1.065)
Drive face boss O.D.	26.970–26.990 (1.0618–1.0626)	26.94 (1.061)
Drive belt width	22.0–23.0 (0.87–0.91)	21.0 (0.83)
Clutch lining thickness	'86:	—
	After '86:	—
Clutch outer I.D.	135.0–135.2 (5.31–5.32)	135.5 (5.33)
Driven face spring free length	98.8 (3.89)	94.0 (3.70)
Driven face O.D.	39.965–39.985 (1.5734–1.5742)	39.94 (1.572)
Movable driven face I.D.	40.000–40.025 (1.5748–1.5758)	40.06 (1.577)
Weight roller O.D.	23.8 (0.94)	23.2 (0.91)
Drive/Driven face depth	—	0.40 (0.016)

TORQUE VALUES

Left crankcase cover bolt	8–12 N·m (0.8–1.2 kg-m, 6–9 ft-lb)
Drive face nut ('86–'87, '92)	80–100 N·m (8.0–10.0 kg-m, 58–72 ft-lb)
(After '92)	90–100 N·m (9.0–10.0 kg-m, 65–72 ft-lb) Apply oil
Drive face seal cover bolt	2.5–4.0 N·m (0.25–0.4 kg-m, 1.8–2.9 ft-lb)
Clutch outer nut	50–60 N·m (5.0–6.0 kg-m, 36–43 ft-lb)
Moveable driven face nut	70–90 N·m (7.0–9.0 kg-m, 51–65 ft-lb)

TOOLS

Special

Lock nut wrench, 39 x 41 mm	07GMA-KS40100 or equivalent commercially available in U.S.A.
Drive pulley holder	07923–KM10000
Clutch spring compressor	07960–KM1000A (Use the three holes marked "B")
Driver	07949–3710001

Common

Extension	07716–0020500 or equivalent commercially available in U.S.A.
Driver	07749–0010000 or 07949–3710001
Pilot, 15 mm	07746–0040300
Pilot, 22 mm	07746–0041000
Attachment, 32 x 35 mm	07746–0010100

DRIVE PULLEY/CLUTCH/DRIVEN PULLEY

TROUBLESHOOTING

Engine starts but scooter won't move

- Worn or damaged drive belt
- Damaged ramp plate
- Worn or damaged clutch lining

Engine stalls or scooter creeps

- Broken clutch weight spring

Poor performance at high speed or lack of power

- Worn drive belt
- Weak driven face spring
- Faulty driven face

LEFT CRANKCASE COVER

REMOVAL/INSTALLATION

Remove the seat and left rear cover (page 13-2).
Remove the rear brake cable clamps from the left crankcase cover by removing the bolts.

Remove the three air cleaner housing mounting bolts.
Loosen the drive belt air cleaner housing connecting tube band.
Remove the two left crankcase cover bolts and remove the left crankcase cover, dowel pins and seal rubber.

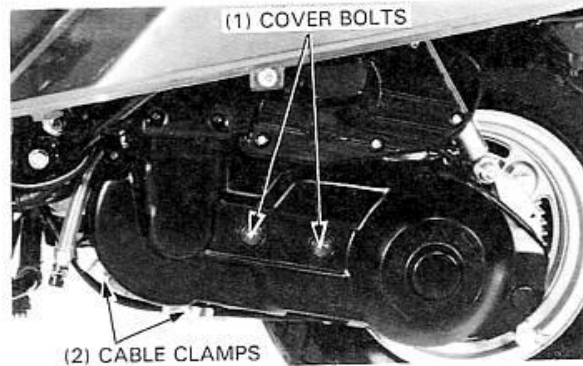

Inspect the rubber seal for cracks, deterioration or other damage and replace if necessary.

Remove the air guide.

Install the left crankcase cover in the reverse order of removal.

TORQUE: 8–12 N·m (0.8–1.2 kg·m, 6–9 ft·lb)

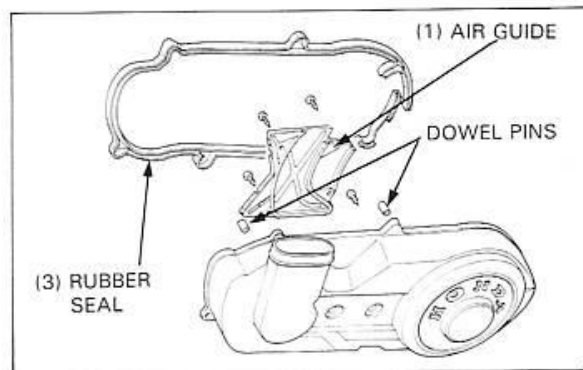

DRIVE BELT

REMOVAL

Remove the left crankcase cover.
Hold the drive pulley with the drive pulley holder and remove the drive pulley nut, washer and drive face.

TOOL:
Drive pulley holder 07923-KM10000

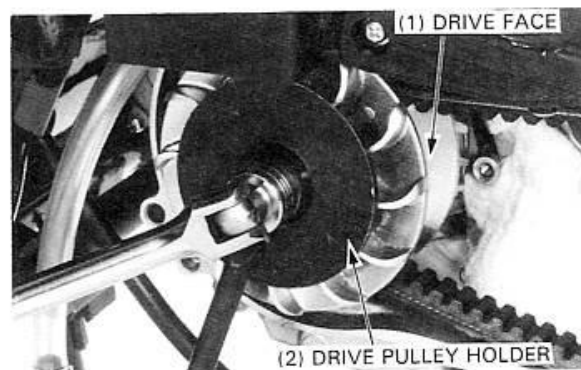

Remove the drive belt.

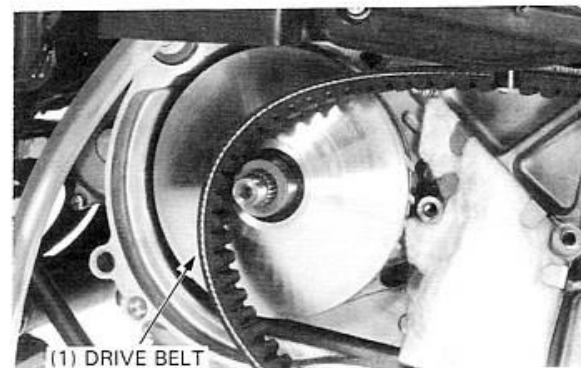

DRIVE PULLEY/CLUTCH/DRIVEN PULLEY

INSPECTION

Check the drive belt for cracks, separation or abnormal or excessive wear.
Measure the drive belt width.

SERVICE LIMIT: 21.0 mm (0.83 in)

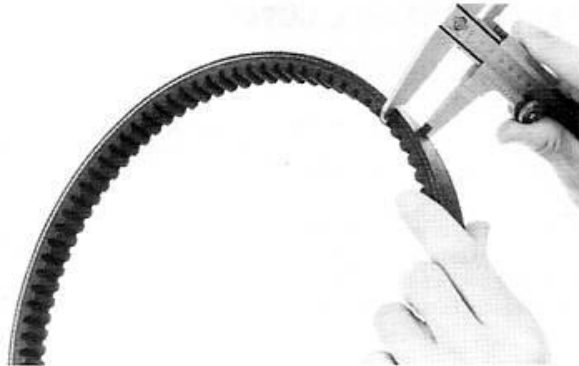

INSTALLATION

Lay the drive belt on the driven pulley.
Squeeze the driven pulley to widen its faces then set the drive belt on the drive pulley face collar.
Reinstall the drive pulley face and washer, hold the drive pulley and tighten the nut.

TORQUE: 80–100 N·m (8.0–10.0 kg·m, 58–72 ft·lb)

Reinstall the left crankcase cover (page 8-3).

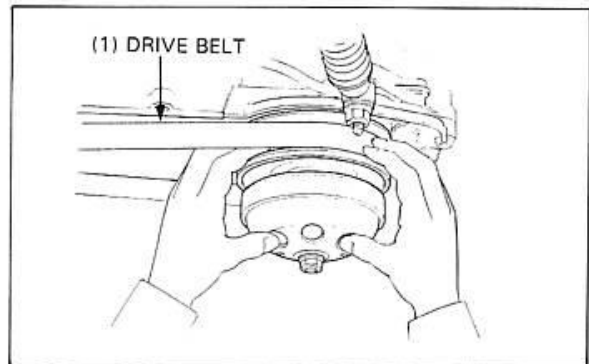

DRIVE PULLEY

REMOVAL

Remove the left crankcase cover (page 8-3).
Remove the drive belt (page 8-3).

Remove the moveable drive face assembly.

NOTE

- If the spline fitting is tight, use a commercially available bearing puller.

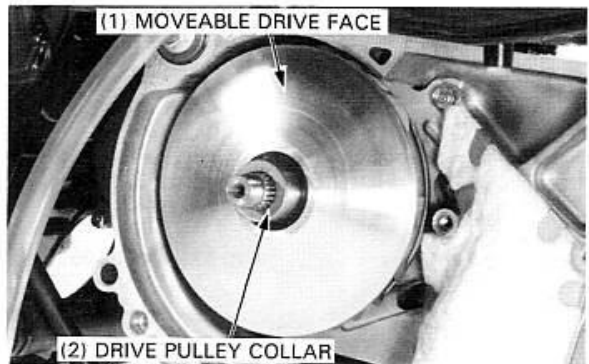

DISASSEMBLY

Remove the drive pulley collar.

Remove the three bolts and the drive face seal cover.

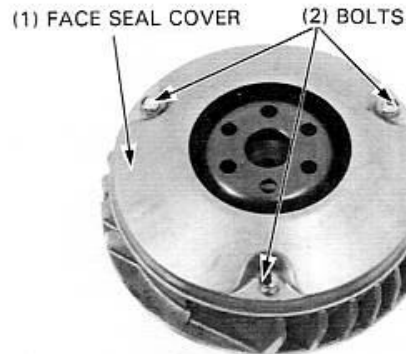

Remove the ramp plate and O-ring.

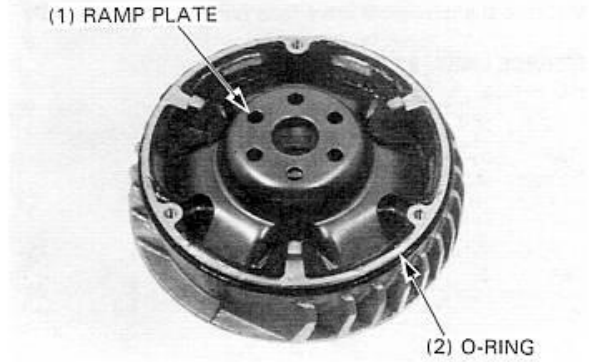

Remove the weight rollers.

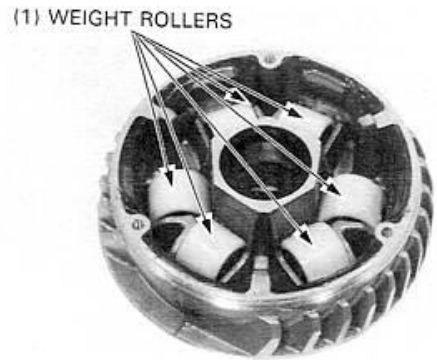

INSPECTION

Check the face seal for wear or damage.
Replace the face seal with a new one if necessary.

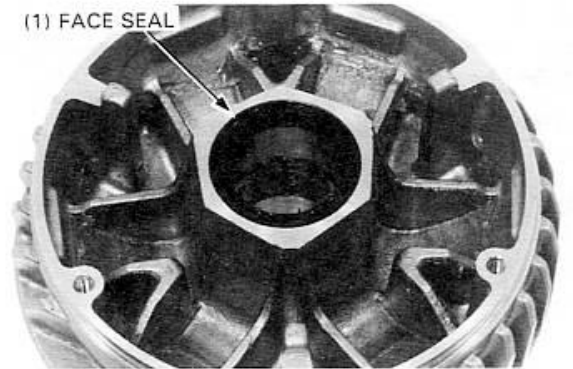

Check each roller for wear or damage.
Measure the weight roller O.D.

SERVICE LIMIT: 23.2 mm

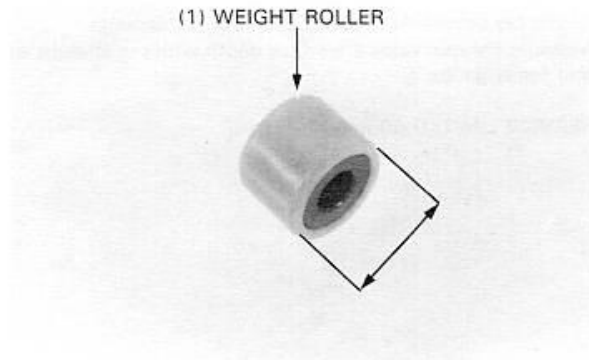

DRIVE PULLEY/CLUTCH/DRIVEN PULLEY

Measure the moveable drive face bushing I.D.

SERVICE LIMIT: 27.06 mm (1.065 in)

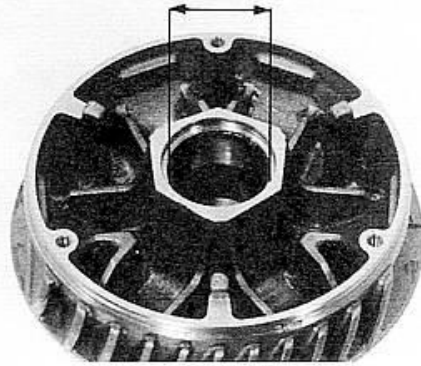

Check the drive face collar for wear or damage.
Measure the O.D. at the drive face sliding surface.

SERVICE LIMIT: 26.94 mm (1.061 in)



Check the drive face for wear or damage.
Measure the drive face depth with the straight edge and feeler gauge.

SERVICE LIMIT: 0.40 mm (0.016 in)

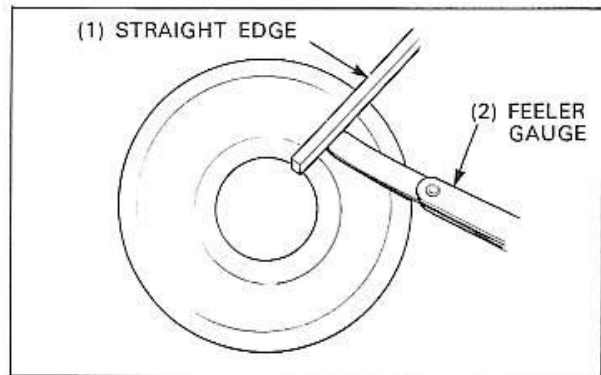

Check the moveable drive face for wear or damage.
Measure the moveable drive face depth with the straight edge and feeler gauge.

SERVICE LIMIT: 0.40 mm (0.016 in)

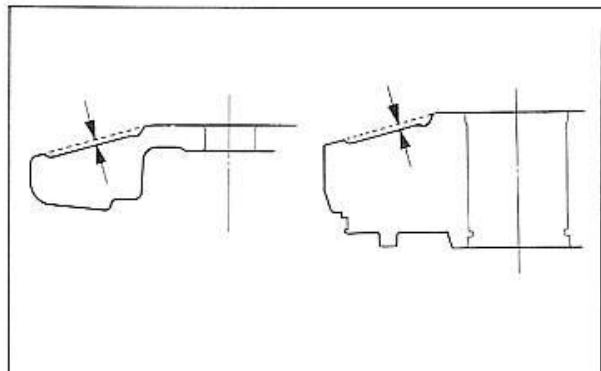

ASSEMBLY

2.5–4.0 N·m
(0.25–0.4 kg-m, 1.8–2.9 ft-lb)

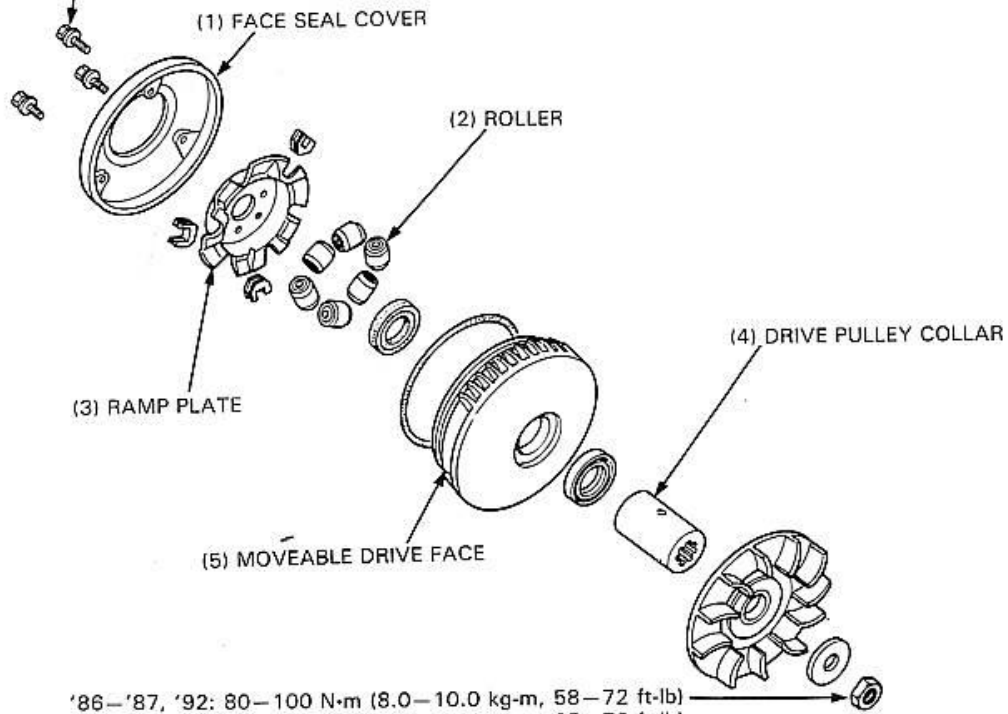

'86–'87, '92: 80–100 N·m (8.0–10.0 kg-m, 58–72 ft-lb)
After '92: 90–100 N·m (9.0–10.0 kg-m, 65–72 ft-lb)

Lubricate the inside of the moveable drive face with grease, then install the weight rollers.

NOTE

- Use 25–30 g of grease and apply to the inside of the moveable drive face evenly.
Specified grease: Lithium based grease
 - Mitsubishi: HD-3
 - Nippon Sekiyu: Lipanox Delux 3
 - Idemitsu: Autolex B
 - Bel-Ray: Moly Lube 124
 - Sta-Lube: MP 3141

Apply grease to the O-ring and install it.

Install the ramp plate, face seal cover, and tighten the cover attaching bolts.

TORQUE: 2.5–4.0 N·m (0.25–0.4 kg-m, 1.8–2.9 ft-lb)

NOTE

- Make sure that the O-ring is in position.
- Wipe out excess grease.

(1) WEIGHT ROLLERS

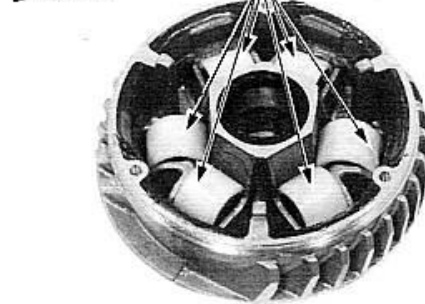

(1) BOLTS

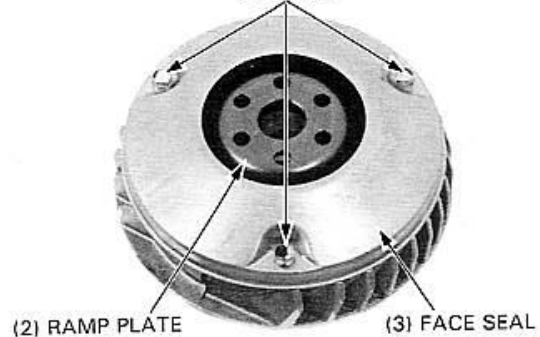

DRIVE PULLEY/CLUTCH/DRIVEN PULLEY

Apply grease to the inside of the drive pulley collar.

NOTE

- Use 4–5 g of grease and apply to the inside of the drive pulley collar evenly.
Specified grease: Lithium based grease
 - Mitsubishi: HD-3
 - Nippon Sekiyu: Lipanox Delux 3
 - Idemitsu: Autolex B
 - Bel-Ray: Moly Lube 124
 - Sta-Lube: MP 3141

Install the drive pulley face collar with the spline side facing out.

Clean off any grease or oil from the drive pulley faces.

INSTALLATION

Install the moveable drive face onto the crankshaft.

Install the drive belt (page 8-4).

Clean the drive pulley face and install it. ✓

Set the washer onto the crankshaft and loosely install the drive pulley nut.

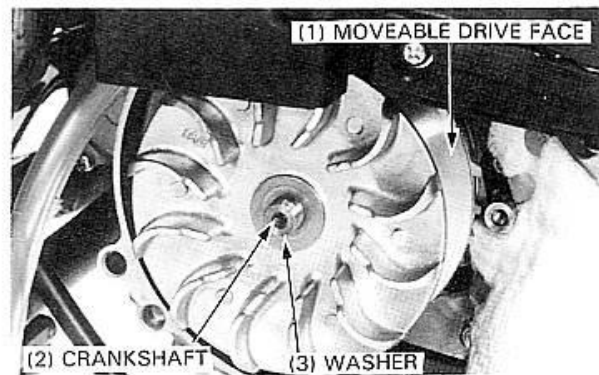
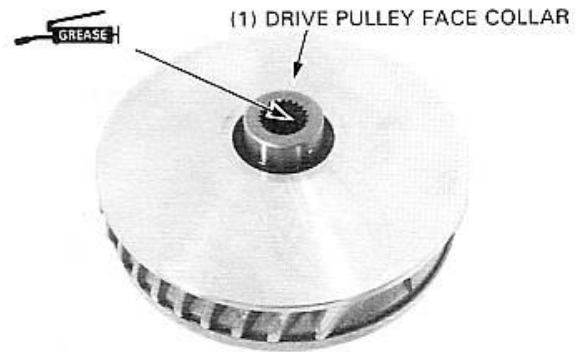

Apply engine oil to the threads of the drive pulley nut (After '92 only).

Hold the drive pulley and tighten the drive pulley nut.

TORQUE:

- '86–'87, '92: 80–100 N·m
(8.0–10.0 kg-m, 58–72 ft-lb)
- After '92: 90–100 N·m
(9.0–10.0 kg-m, 65–72 ft-lb)

CAUTION

- Do not allow oil or grease on the drive belt or pulley faces.

Reinstall the removed parts in the reverse order of removal.

TOOL:

Drive pulley holder 07923–KM10000

CLUTCH/DRIVEN PULLEY

REMOVAL

Remove the left crankcase cover, drive pulley face and drive belt (page 8-3).

Hold the clutch outer with drive pulley holder and remove the driven pulley nut and clutch outer.

TOOL:

Drive pulley holder 07923–KM10000

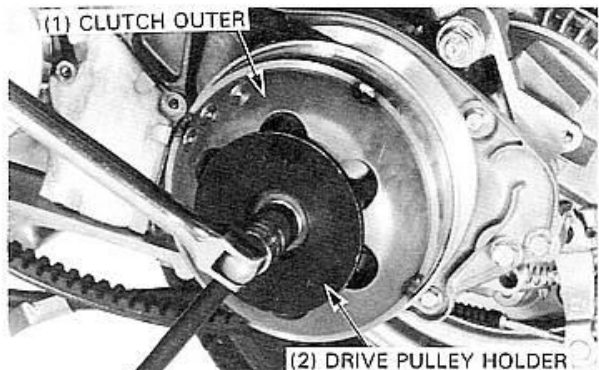
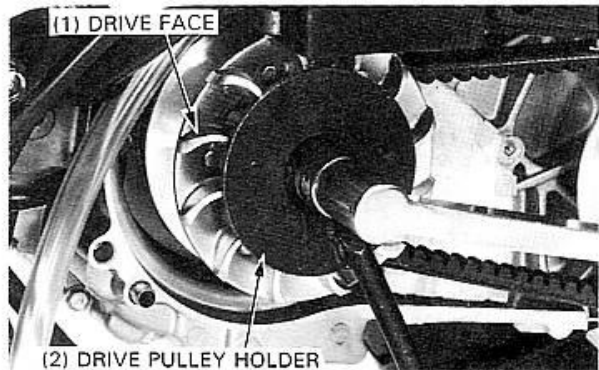

DRIVE PULLEY/CLUTCH/DRIVEN PULLEY

Remove the driven pulley/clutch assembly.

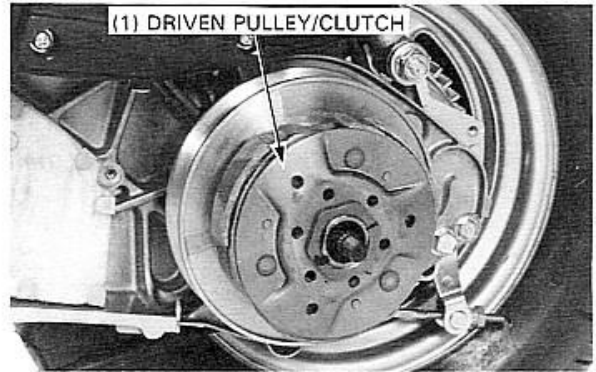

INSPECTION

Check the clutch outer for wear or damage.
Measure the clutch outer I.D.

SERVICE LIMIT: 135.5 mm (5.33 in)

Check the clutch shoes for wear or damage.
Measure the clutch lining thickness.

SERVICE LIMIT: '86: 1.5 mm (0.06 in)
After '86: 0.5 mm (0.02 in)

NOTE

- Replace the clutch shoes as a set.

DISASSEMBLY

Hold and compress the driven pulley/clutch assembly with the clutch spring compressor.

NOTE

- Do not tighten the tool more than necessary to avoid damaging the drive plate.

TOOL:

Clutch spring compressor 07960-KM1000A

NOTE

- Use the three holes marked B on the tool.

Set the tool in a vise and remove the lock nut.

TOOLS:

Lock nut wrench, 39 x 41 mm 07GMA-KS40100
Equivalent commercially
available in U.S.A.

Extension

07716-0020500
Equivalent commercially
available in U.S.A.

Loosen the tool and disassemble the driven pulley/clutch assembly.

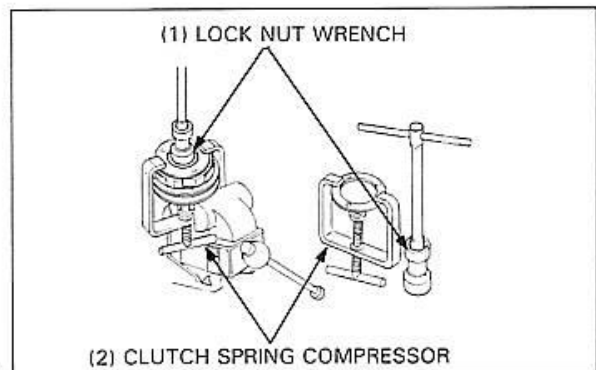
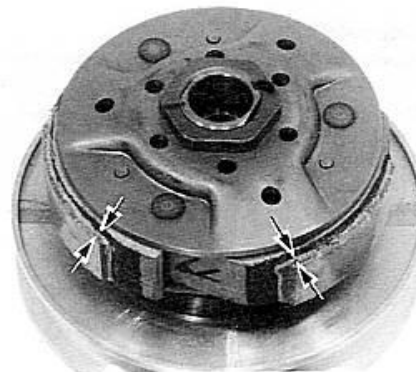
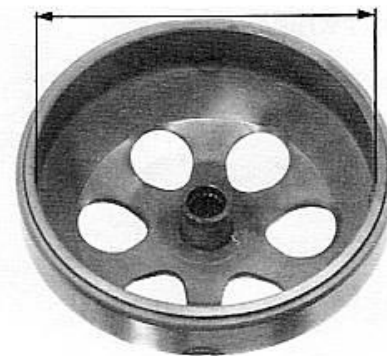

DRIVE PULLEY/CLUTCH/DRIVEN PULLEY

Remove the circlips and disassemble the clutch.

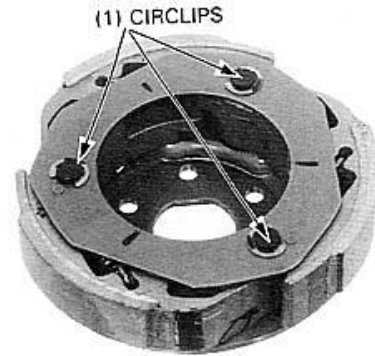

DRIVEN PULLEY DISASSEMBLY

Remove the seal collar.

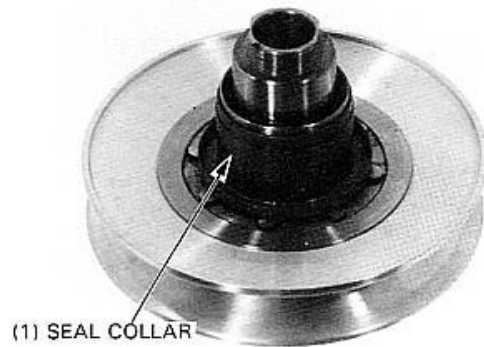

Pull out the guide roller pins and guide rollers.
Remove the moveable driven face from the driven face.

Remove the O-rings from the moveable driven face.

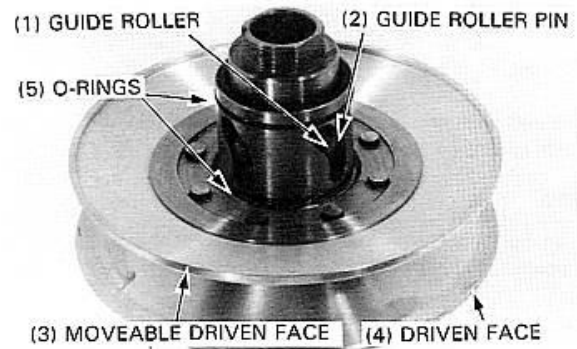

Remove the oil seal from the moveable driven face.

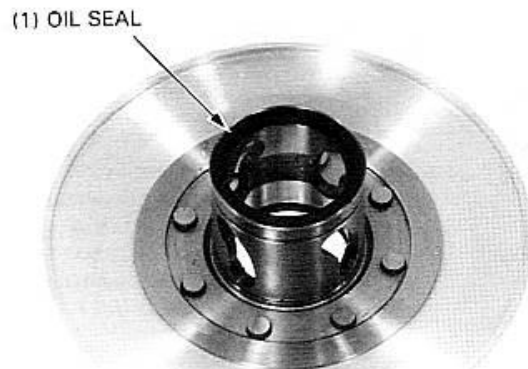

DRIVE PULLEY/CLUTCH/DRIVEN PULLEY

INSPECTION

Measure the driven face spring free length.

SERVICE LIMIT: 94.0 mm (3.70 in)

Check the driven face spring for damage or loss of tension, and replace if necessary.

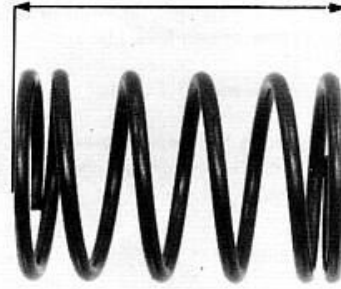

Check the driven face assembly for wear or damage.
Measure the driven face O.D.

SERVICE LIMIT: 39.94 mm (1.572 in)

Turn the inner race of each bearing with your finger.
The bearing should turn smoothly and quietly. Also check that the bearing outer races fit tightly in the driven face.

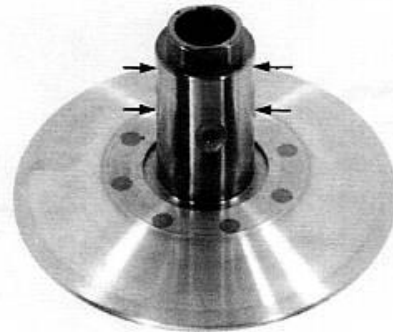

Check the driven face for wear or damage.
Measure the driven face depth with the straight edge and feeler gauge.

SERVICE LIMIT: 0.40 mm (0.016 in)

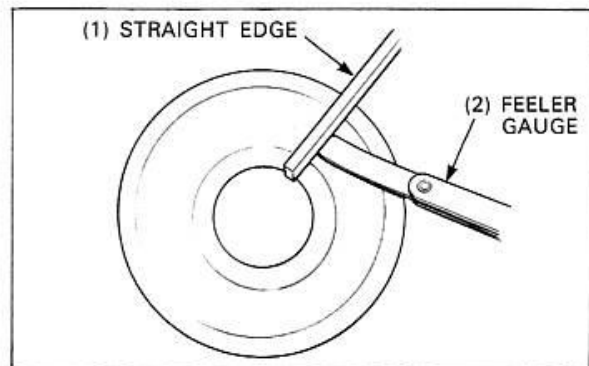

Check the movable driven face for wear or damage.
Measure the moveable drive face depth with the straight edge and feeler gauge.

SERVICE LIMIT: 0.40 mm (0.016 in)

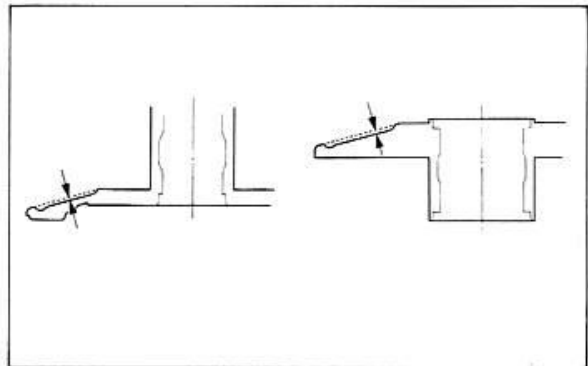

DRIVE PULLEY/CLUTCH/DRIVEN PULLEY

Check the moveable driven face for wear or scoring.
Measure the moveable driven face I.D.

SERVICE LIMIT: 40.06 mm (1.577 in)

Check the guide groove for stepped wear.
Check the oil seal and O-ring for damage or wear.
Replace if necessary.

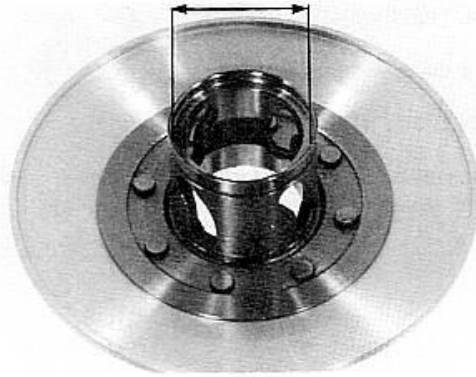

CLUTCH ASSEMBLY

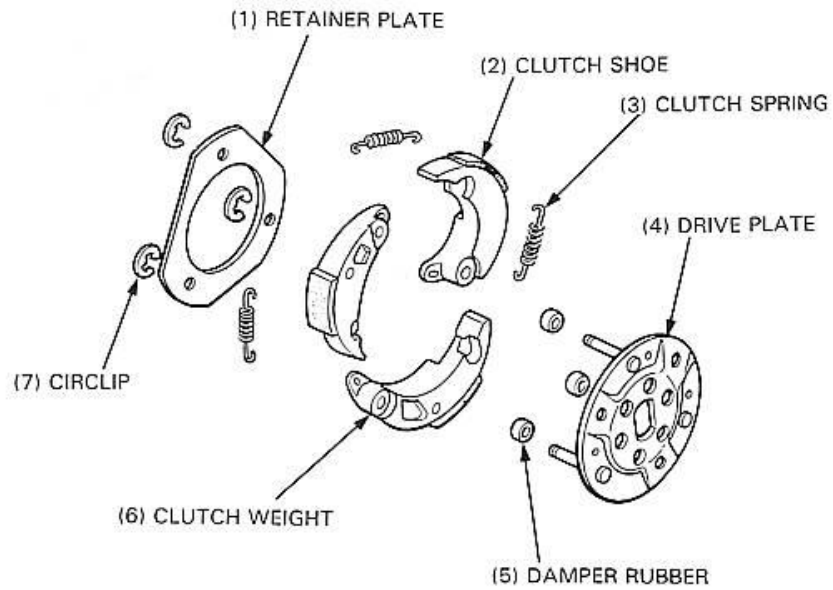

DRIVE PULLEY/CLUTCH/DRIVEN PULLEY

Install the damper rubbers on the drive plate pivot pins.

Apply a small amount of grease to the clutch weight pivot pins.

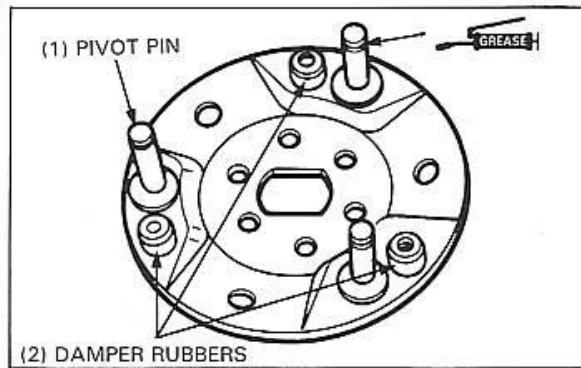

Attach the clutch weights and the clutch springs, and install them onto the drive plate.

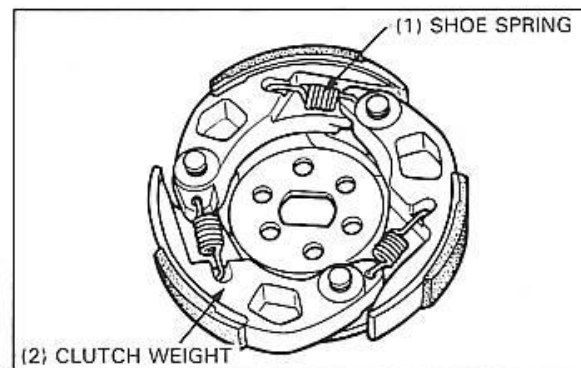

Secure the retainer plate with the circlips.

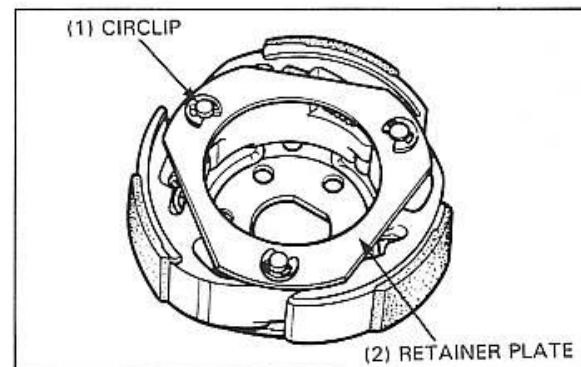

DRIVEN PULLEY ASSEMBLY

Apply inside of the driven face with grease.

NOTE

- Use 25–30 g of grease and apply to the inside evenly.
Specified grease: Lithium based grease
 - Mitsubishi: HD-3
 - Nippon Sekiyu: Lipanox Deluxe 3
 - Idemitsu: Autolex B
 - Bel-Ray: Moly Lube 124
 - Sta-Lube: MP 3141

DRIVE PULLEY/CLUTCH/DRIVEN PULLEY

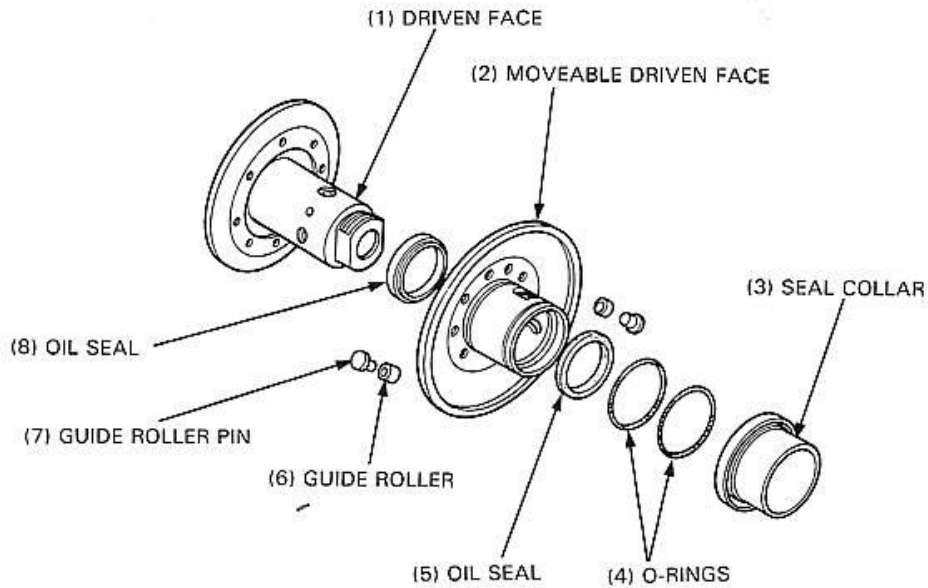

Clean the moveable driven face.
 Install a new oil seal onto the moveable driven face.
 Coat the new O-rings with grease and install them onto the moveable driven face.
 Lubricate the inside of the moveable driven face with grease.

NOTE

- Use 4–5 g of grease and apply to the inside evenly.
 Specific grease: Lithium based grease
 - Mitsubishi HD-3
 - Nippon sekiyu: Lipanox delux 3
 - Idemitsu: Autolex B
 - Bel-Ray: Moly lube 124
 - Sta-Lube: MP 3141

Install the moveable driven face onto the driven face.
 Apply a small amount of grease to the guide rollers and pins and install them into the hole of the driven face.

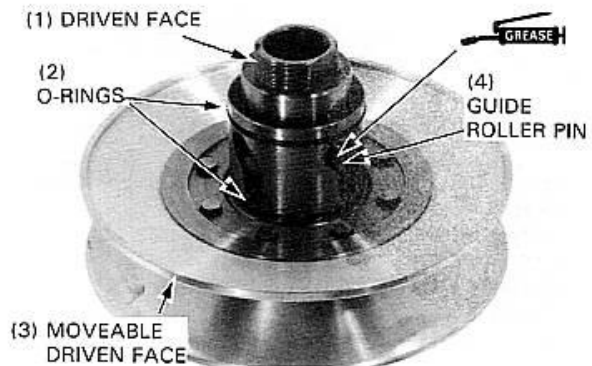
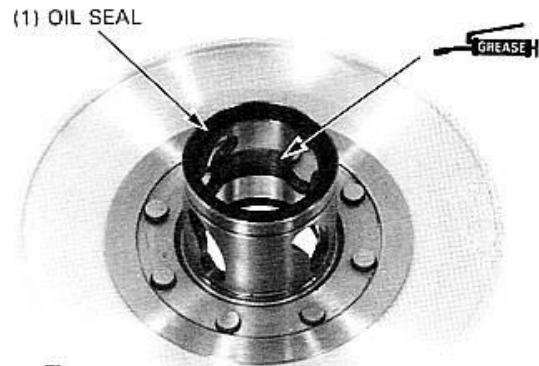

DRIVE PULLEY/CLUTCH/DRIVEN PULLEY

Install the seal collar.

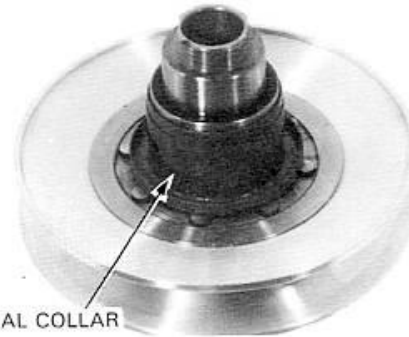

(1) SEAL COLLAR

Set the driven pulley assembly, driven face spring and clutch assembly onto the clutch compressor.

NOTE

- Use the three holes marked "B" on the tool.

Align the flat surface of the driven face with the flat on the clutch drive plate.

Compress the tool and install the lock nut loosely. Set the tool in a vise and tighten the lock nut to the specified torque.

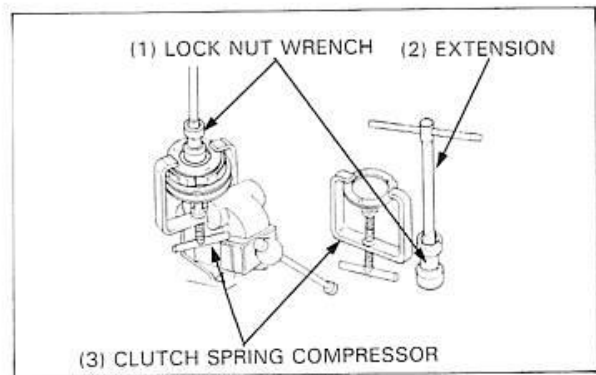

TORQUE: 70–90 N·m (7.0–9.0 kg·m, 51–65 ft·lb)

TOOLS:

Clutch spring compressor	07960–KM1000A
Lock nut wrench, 39 x 41 mm	07GMA–KS40100 or equivalent commercially available in U.S.A.
Extension	07716–0020500 or equivalent commercially available in U.S.A.

Remove the driven pulley/clutch assembly from the tool.

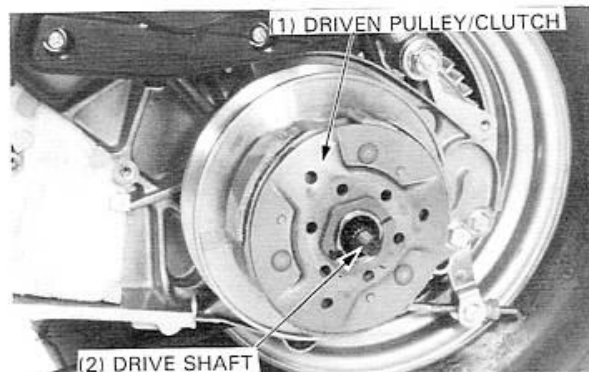

INSTALLATION

Install the driven pulley/clutch assembly onto the drive shaft. If some grease remains at the drive shaft end, wipe it out.

Install the clutch outer and tighten the nut while holding the clutch outer with the drive pulley holder.

TORQUE: 50–60 N·m (5.0–6.0 kg·m, 36–43 ft·lb)

TOOL:

Drive pulley holder	07923–KM10000
---------------------	---------------

Install the drive belt (page 8-4).
Install the left crankcase cover (page 8-3).
Install the removed parts in reverse order of the removal.

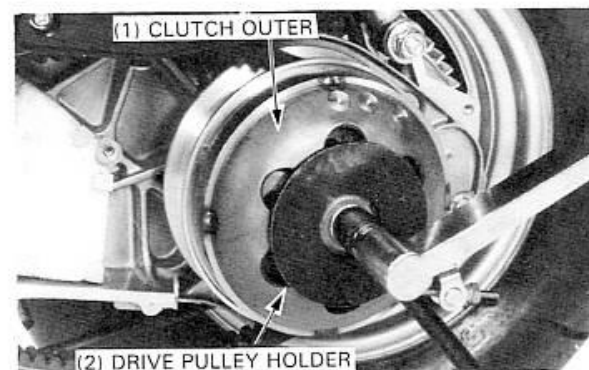

Click below to see pages

9. FINAL REDUCTION

SERVICE INFORMATION	9-1	FINAL REDUCTION INSPECTION	9-2
TROUBLESHOOTING	9-1	FINAL REDUCTION ASSEMBLY	9-4
FINAL REDUCTION DISASSEMBLY	9-2		

SERVICE INFORMATION

SPECIFICATIONS

Specified oil: Honda 4-stroke engine oil, SAE 10W-40 or equivalent (page 2-1)

Oil capacity: 0.15 liter (0.16 US qt, 0.13 Imp qt) at change
0.2 liter (0.21 US qt, 0.18 Imp qt) at disassembly

TORQUE VALUES

Transmission case cover	6 mm	8-12 N·m (0.8-1.2 kg-m, 6-9 ft-lb)
	8 mm	20-24 N·m (2.0-2.4 kg-m, 14-18 ft-lb)
	10 mm	10-15 N·m (1.0-1.5 kg-m, 7-11 ft-lb)

TOOLS

Special

Bearing remover set, 12 mm (Bearing remover, 12 mm) (Remover weight)	07936-1660001 Not available in U.S.A. (07936-1660100) (07741-0010201) or 07936-3710200
Bearing remover set, 20 mm (Bearing remover, 20 mm) (Remover handle) (Remover weight)	07936-3710001 Not available in U.S.A. (07936-3710600) (07936-3710100) (07741-0010201) or 07936-3710200
Shaft protector	07931-1870000

Common

Attachment, 37 x 40 mm	07746-0010200
Attachment, 52 x 55 mm	07746-0010400
Pilot, 12 mm	07746-0040200
Pilot, 22 mm	07746-0041000
Pilot, 20 mm	07746-0040500
Pilot, 25 mm	07746-0040600
Driver	07749-0010000 or 07949-3710001
Driver, 22 mm I.D.	07746-0020100

TROUBLESHOOTING

Engine starts but scooter won't move

- Damaged or seized transmission

Abnormal noise

- Worn, seized or chipped gears
- Worn, bearing

Oil leaks

- Oil level too high
- Worn or damaged oil seal

STATOR REMOVAL

Remove the wire grommet from the groove in the cover.
 Remove the breather plate and ignition pulse generator.
 Remove the three stator attaching bolts and stator.

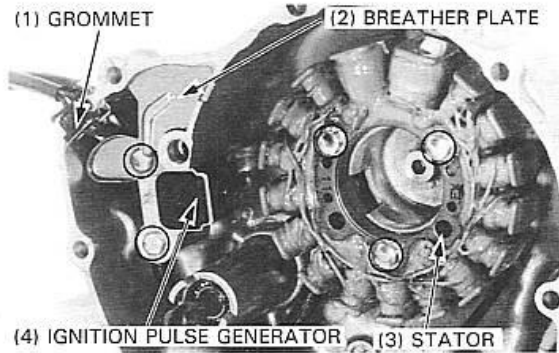

FLYWHEEL REMOVAL

Remove the oil orifice from the end of the crankshaft.



Hold the flywheel with a flywheel holder and remove the flywheel nut and washer.

Remove the oil orifice drive pin from the crankshaft.

NOTE

- Be careful not to drop the drive pin into the crankcase.

TOOL:

Flywheel holder 07725—0040000 or
 equivalent commercially
 available in U.S.A.

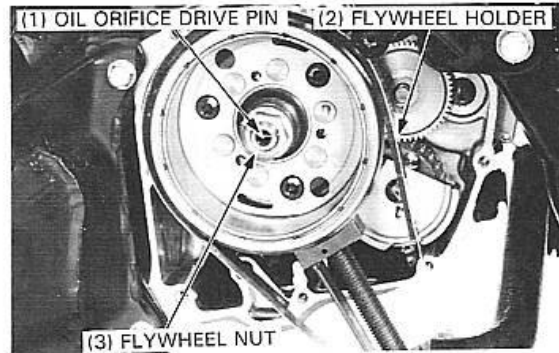

Remove the flywheel with a flywheel puller.

TOOL:

Flywheel puller 07933—KM10000

Remove the woodruff key from the crankshaft.

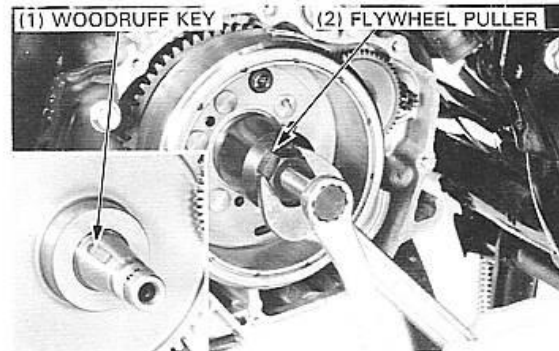

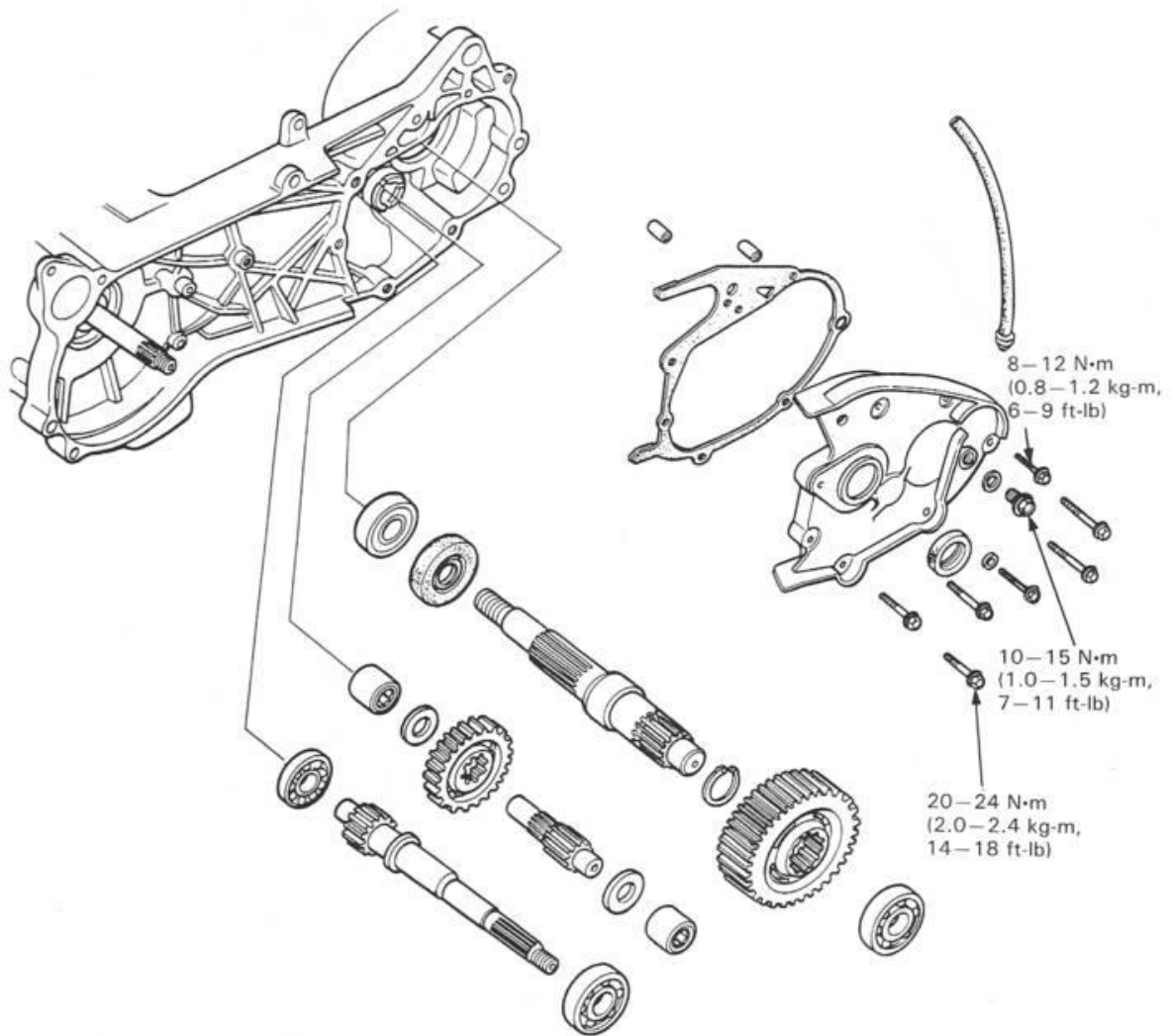

Contents -- Page 9-1 >>

Click below to see pages

9. FINAL REDUCTION

SERVICE INFORMATION	9-1	FINAL REDUCTION INSPECTION	9-2
TROUBLESHOOTING	9-1	FINAL REDUCTION ASSEMBLY	9-4
FINAL REDUCTION DISASSEMBLY	9-2		

SERVICE INFORMATION

SPECIFICATIONS

Specified oil: Honda 4-stroke engine oil, SAE 10W-40 or equivalent (page 2-1)

Oil capacity: 0.15 liter (0.16 US qt, 0.13 Imp qt) at change
0.2 liter (0.21 US qt, 0.18 Imp qt) at disassembly

TORQUE VALUES

Transmission case cover	6 mm	8-12 N·m (0.8-1.2 kg-m, 6-9 ft-lb)
	8 mm	20-24 N·m (2.0-2.4 kg-m, 14-18 ft-lb)
	10 mm	10-15 N·m (1.0-1.5 kg-m, 7-11 ft-lb)

TOOLS

Special

Bearing remover set, 12 mm (Bearing remover, 12 mm) (Remover weight)	07936-1660001 Not available in U.S.A. (07936-1660100) (07741-0010201) or 07936-3710200
Bearing remover set, 20 mm (Bearing remover, 20 mm) (Remover handle) (Remover weight)	07936-3710001 Not available in U.S.A. (07936-3710600) (07936-3710100) (07741-0010201) or 07936-3710200
Shaft protector	07931-1870000

Common

Attachment, 37 x 40 mm	07746-0010200
Attachment, 52 x 55 mm	07746-0010400
Pilot, 12 mm	07746-0040200
Pilot, 22 mm	07746-0041000
Pilot, 20 mm	07746-0040500
Pilot, 25 mm	07746-0040600
Driver	07749-0010000 or 07949-3710001
Driver, 22 mm I.D.	07746-0020100

TROUBLESHOOTING

Engine starts but scooter won't move

- Damaged or seized transmission

Abnormal noise

- Worn, seized or chipped gears
- Worn, bearing

Oil leaks

- Oil level too high
- Worn or damaged oil seal

FINAL REDUCTION

FINAL REDUCTION DISASSEMBLY

Remove the driven pulley (page 8-9).
Drain the transmission oil (page 2-6).
Remove the rear wheel (page 15-2).
Remove the transmission case cover by removing the attaching bolts.
Remove the gasket and dowel pins.

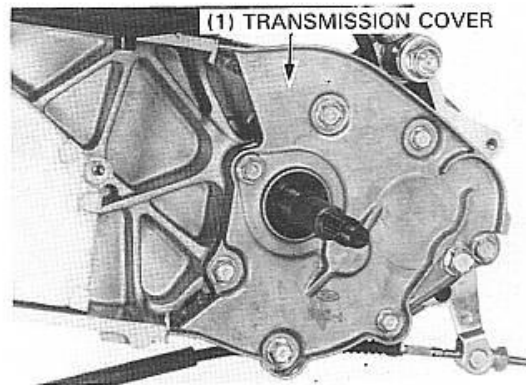

Remove the thrust washers.
Remove the final gear and final shaft.
Remove the countershaft and washer.

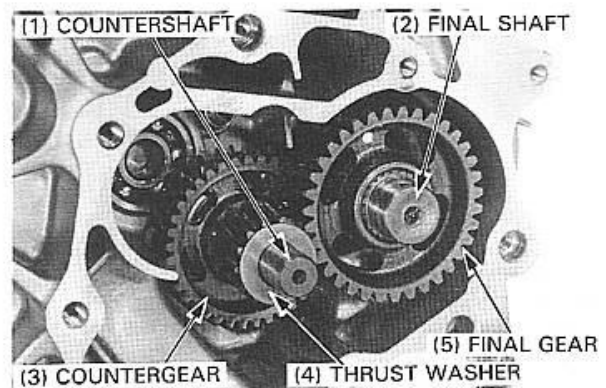

FINAL REDUCTION INSPECTION

Inspect the drive shaft and gear for wear or damage.
Turn the drive shaft. The drive shaft should turn smoothly and quietly. Also check the bearing inner and outer races fit tightly in the transmission cover and drive shaft.
Remove and discard the bearing if the races do not turn smoothly, quietly, or if they fit loosely in the drive shaft or transmission cover.

If it is necessary to replace the shaft or bearing, drive the drive shaft out of the transmission cover with the bearing attached, then remove the bearing from the drive shaft using a commercially available bearing puller and Shaft Protector.

Remove the drive shaft oil seal from the transmission cover.

NOTE

- If the drive shaft is removed from the transmission cover, the bearing must be replaced with a new one.

Inspect the countershaft and gear for wear or damage.

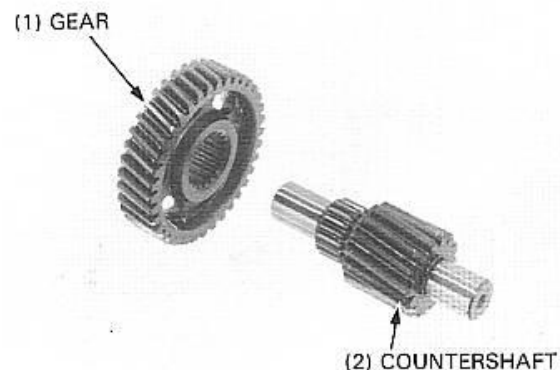
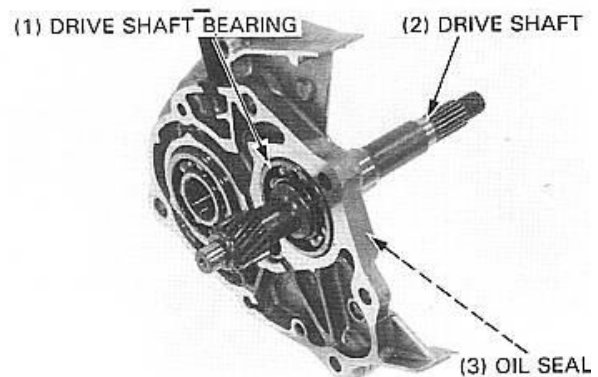

Inspect the final gear and final shaft for seizure, wear or damage.

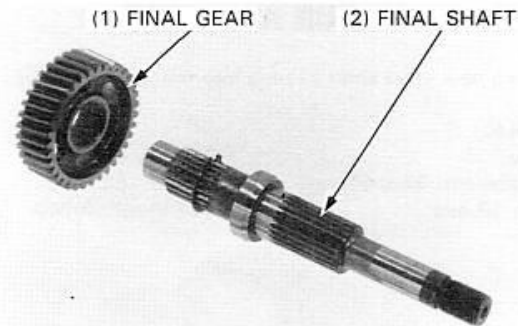

Turn the inner race of the final shaft bearing and the countershaft bearing with your finger. The bearings should turn smoothly and quietly. Also check that the bearing outer races fit tightly in the transmission cover. Remove and discard the final shaft bearing if the race does not turn smoothly, quietly, or if it fits loosely in the transmission cover.

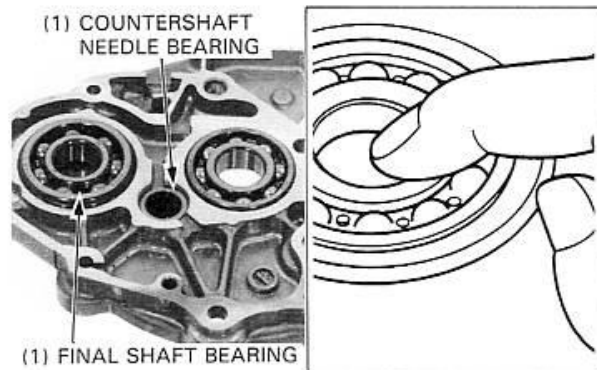

NOTE

- The countershaft needle bearing must be replaced with the transmission case cover as a set.

TOOLS:

Bearing remover set, 20 mm	07936-3710001
	Not available in U.S.A.
-Bearing remover, 20 mm	07936-3710600
-Remover handle	07936-3710100
-Remover weight	07936-3710200 or
	07741-0010201

Check the final shaft oil seal for wear or damage. Turn the inner race of the drive shaft, final shaft and countershaft bearings with your finger. The bearings should turn smoothly and quietly. Also check that the bearing outer race fits tightly in the left crankcase. Remove and discard the drive shaft and final shaft bearings if the races do not turn smoothly, quietly, or if they fit loosely in the left crankcase.

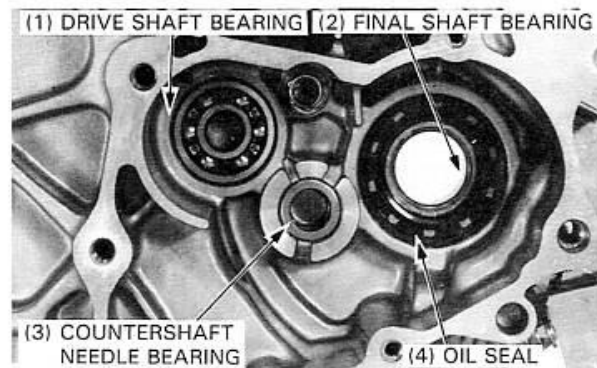

NOTE

- The countershaft needle bearing must be replaced with the left crankcase as a set.

Remove the drive shaft bearing using a Bearing Remover, 12 mm.

TOOLS:

Bearing remover set, 12 mm	07936-1660001
	Not available in U.S.A.
-Bearing remover, 12 mm	07936-1660100
-Remover weight	07936-3710200 or
	07741-0010201



FINAL REDUCTION

FINAL REDUCTION ASSEMBLY

Drive a new drive shaft bearing into the left crankcase.

TOOLS:

Driver	07749-0010000
Attachment, 37 x 40 mm	07746-0010200
Pilot, 12 mm	07746-0040200

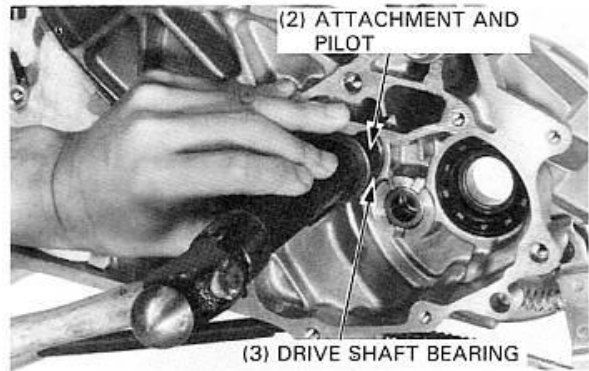

Drive a new final shaft bearing into the left crankcase.

TOOLS:

Driver	07749-0010000
Attachment, 52 x 55 mm	07746-0010400
Pilot, 22 mm	07746-0040600

Install the final shaft oil seal.

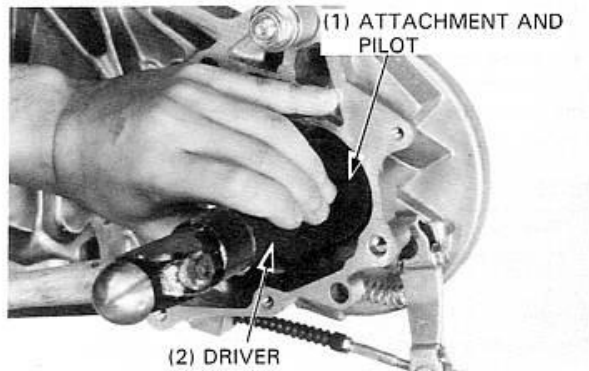

Drive a new final shaft bearing into the transmission cover.

TOOLS:

Driver	07749-0010000
Attachment, 52 x 55 mm	07746-0010400
Pilot, 20 mm	07746-0040500

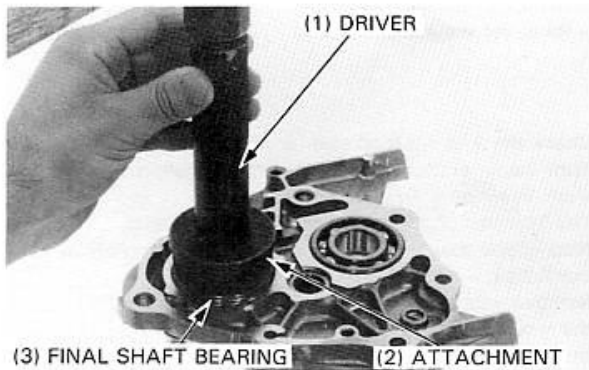

Drive a new drive shaft bearing into the transmission cover.

TOOLS:

Driver	07749-0010000
Attachment, 52 x 55 mm	07746-0010400
Pilot, 22 mm	07746-0041000

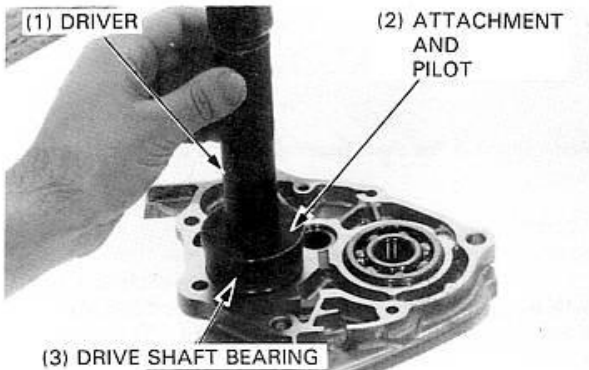

FINAL REDUCTION

Install the drive shaft into the transmission bearing.
Place the driver as shown and press the drive shaft into the transmission cover using a hydraulic press.

TOOL:

Driver, 22 mm I.D. 07746-0020100

Install the oil seal onto the drive shaft.

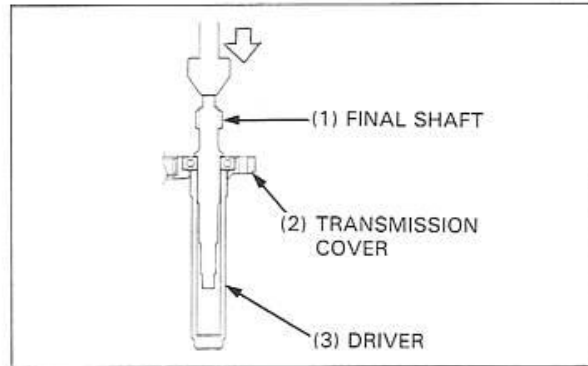

Install the countershaft, countergear, final shaft, final gear and thrust washers.

NOTE

- Note the final gear installation direction.

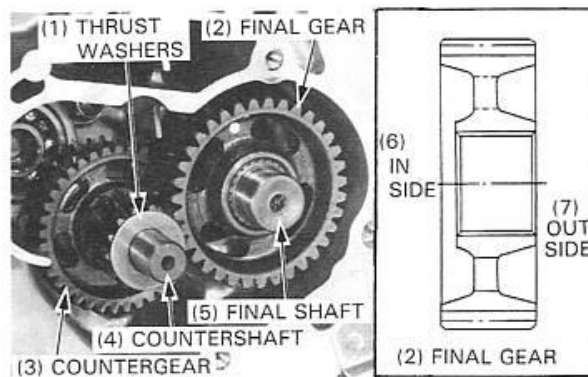

Install the dowel pins and a new gasket.

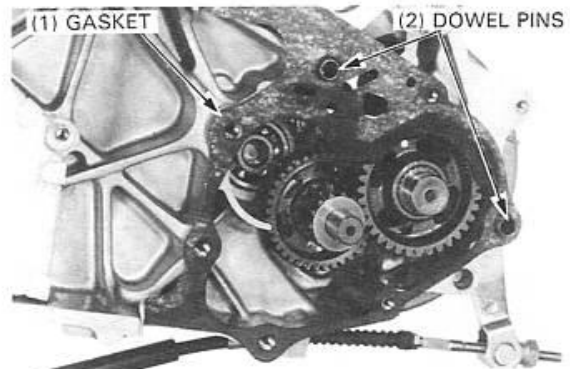

Install the transmission case cover and tighten the bolts.

TORQUE:

- 6 mm bolt 8–12 N·m (0.8–1.2 kg-m, 6–9 ft-lb)
- 8 mm bolt 20–24 N·m (2.0–2.4 kg-m, 14–18 ft-lb)
- 10 mm bolt 10–14 N·m (1.0–1.4 kg-m, 7–10 ft-lb)

Install the moveable driven face/clutch (Page 8-15).
Install the drive pulley, drive belt and left crankcase cover (pages 8-4 and 8-8).
Install the rear wheel (Page 15-4).
Fill the final reduction case with the specified oil (page 2-1).

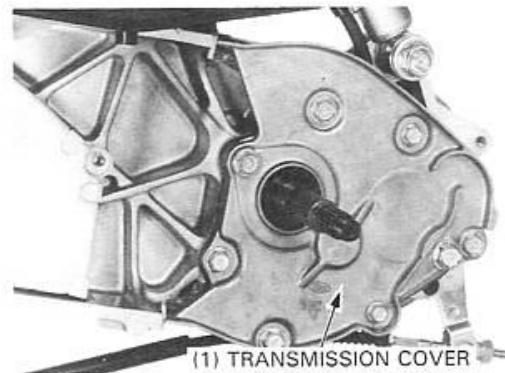

ALTERNATOR/STARTER CLUTCH

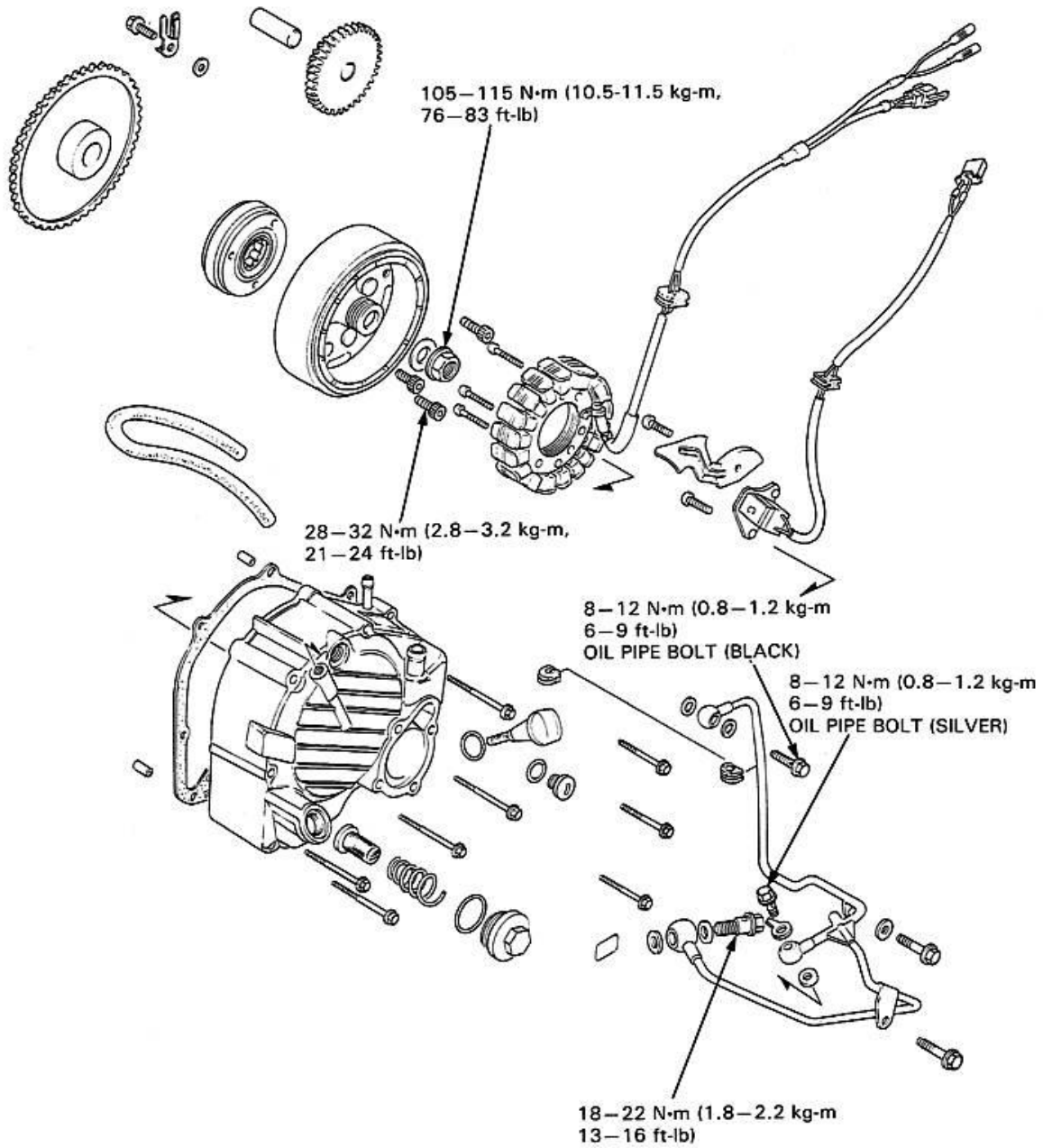

10. ALTERNATOR/STARTER CLUTCH

SERVICE INFORMATION	10-1	STARTER CLUTCH	10-4
RIGHT CRANKCASE COVER REMOVAL	10-2	FLYWHEEL INSTALLATION	10-6
STATOR REMOVAL	10-3	STATOR INSTALLATION	10-7
FLYWHEEL REMOVAL	10-3	RIGHT CRANKCASE COVER INSTALLATION	10-7

SERVICE INFORMATION

GENERAL

- Refer to section 17 for troubleshooting and inspection of the alternator.
- Refer to section 19 for service procedures and information of the starter motor.
- The alternator and starter clutch can be serviced with the engine installed in the frame.

SPECIFICATIONS

ITEM	STANDARD mm (in)	SERVICE LIMIT mm (in)
Starter driven gear I.D.	22.026–22.045 (0.8672–0.8679)	22.10 (0.870)
Starter driven gear O.D.	42.195–42.208 (1.6612–1.6617)	42.15 (1.659)
One way clutch outer I.D.	58.897–58.927 (2.3187–2.3200)	58.98 (2.322)

TORQUE VALUES

Flywheel nut	105–115 N·m (10.5–11.5 kg-m, 76–83 ft-lb)	Apply molybdenum disulfide grease to the threads.
Oil pipe bolt	8 mm: 8–12 N·m (0.8–1.2 kg-m, 6–9 ft-lb) 12 mm: 18–22 N·m (1.8–2.2 kg-m, 13–16 ft-lb)	
One way clutch bolt	28–32 N·m (2.8–3.2 kg-m, 21–24 ft-lb)	Apply a locking agent

TOOLS

Special	
Flywheel puller	07933–KM10000
Common	
Flywheel holder	07725–0040000 or Band strap wrench (equivalent commercially available in U.S.A.)

ALTERNATOR/STARTER CLUTCH

RIGHT CRANKCASE COVER REMOVAL

Remove the seat and right rear cover (page 13-2).
Drain the coolant (page 12-2) and engine oil (page 2-2).

Remove the two oil pipe clamp bolts, two 8 mm oil pipe bolts, 12 mm oil pipe bolt and washers, then remove the oil pipe.

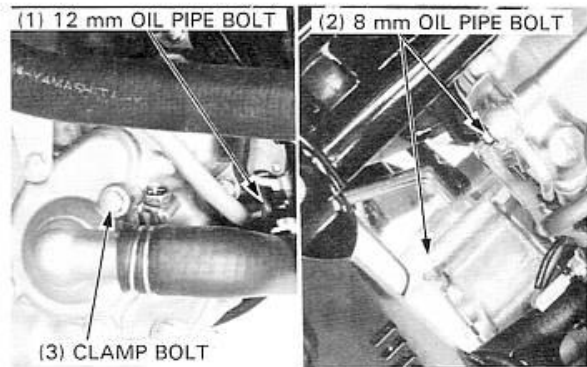

Disconnect the water hoses from the water pump.

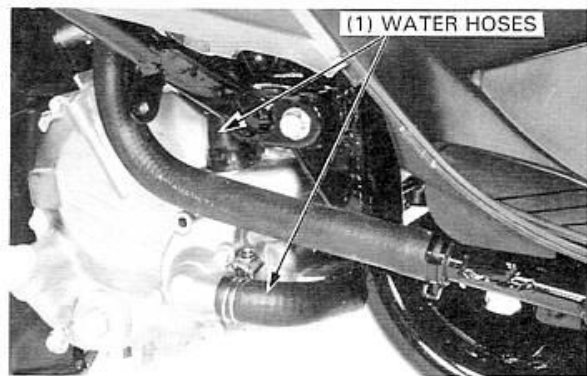

Disconnect the pulse generator and alternator wire connectors.

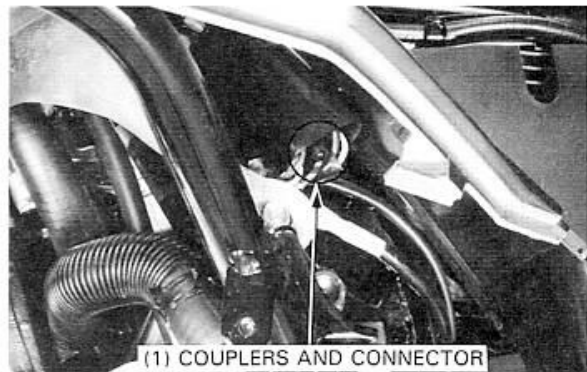

Disconnect the crankcase breather tube from the right crankcase cover.

Remove the right crankcase cover attaching bolts and right crankcase cover.

Remove the dowel pins and gasket.

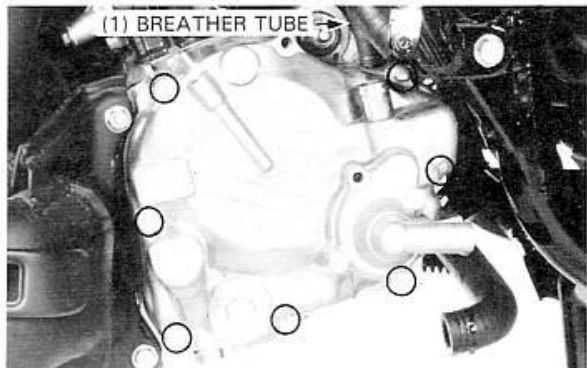

STATOR REMOVAL

- Remove the wire grommet from the groove in the cover.
- Remove the breather plate and ignition pulse generator.
- Remove the three stator attaching bolts and stator.

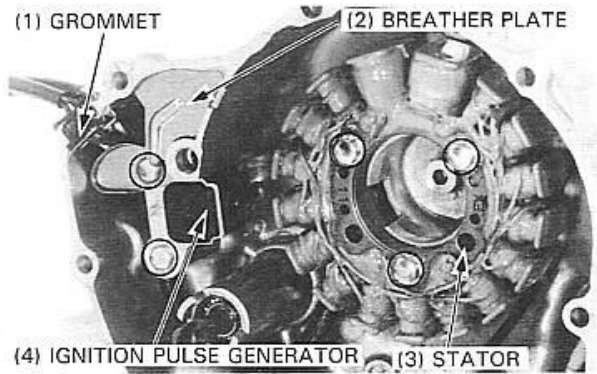

FLYWHEEL REMOVAL

- Remove the oil orifice from the end of the crankshaft.

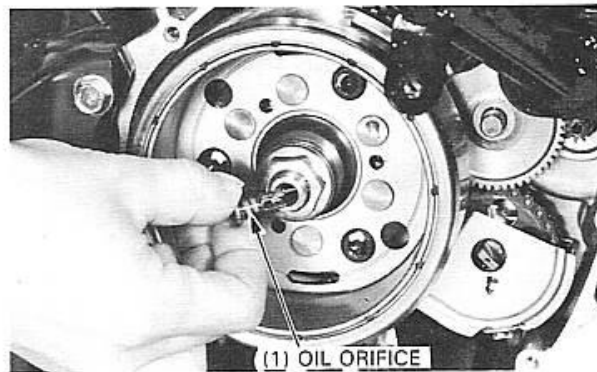

- Hold the flywheel with a flywheel holder and remove the flywheel nut and washer.

- Remove the oil orifice drive pin from the crankshaft.

NOTE

- Be careful not to drop the drive pin into the crankcase.

TOOL:

Flywheel holder

07725-0040000 or equivalent commercially available in U.S.A.

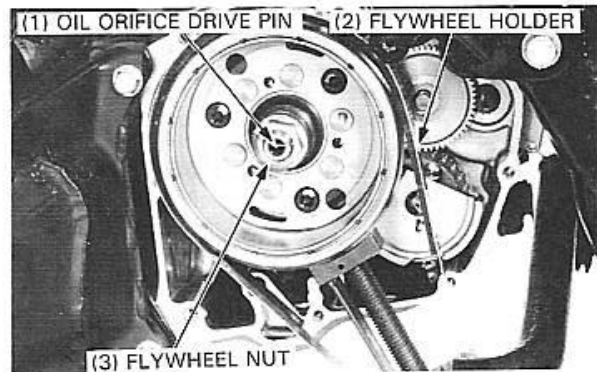

- Remove the flywheel with a flywheel puller.

TOOL:

Flywheel puller

07933-KM10000

- Remove the woodruff key from the crankshaft.

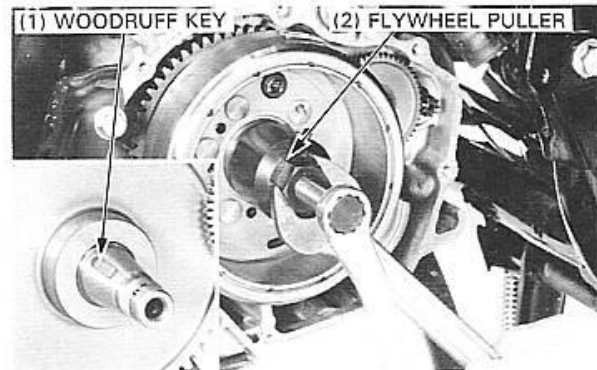

ALTERNATOR/STARTER CLUTCH

STARTER CLUTCH

STARTER IDLE GEAR/DRIVEN GEAR REMOVAL

Remove the starter idle gear.

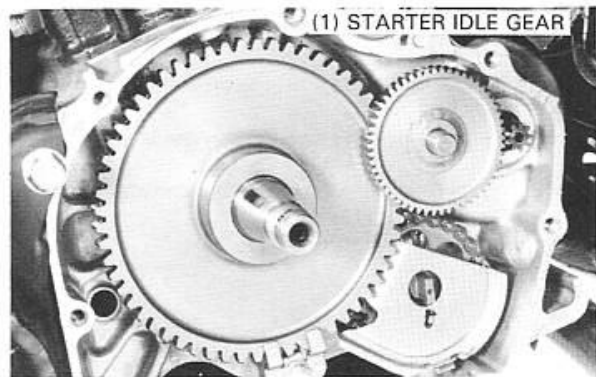

Remove the set plate.

Remove the starter driven gear and idle gear shaft.

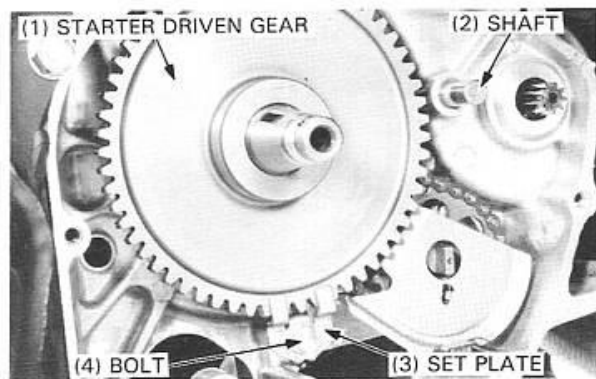

STARTER CLUTCH INSPECTION

Inspect the starter driven gear for wear or damage.
Measure the starter driven gear I.D. and O.D.

SERVICE LIMITS: I.D. 22.10 mm (0.870 in)
O.D. 42.15 mm (1.659 in)

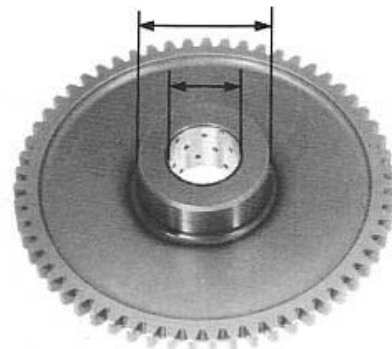

Inspect the starter idle gear and shaft for wear or damage.

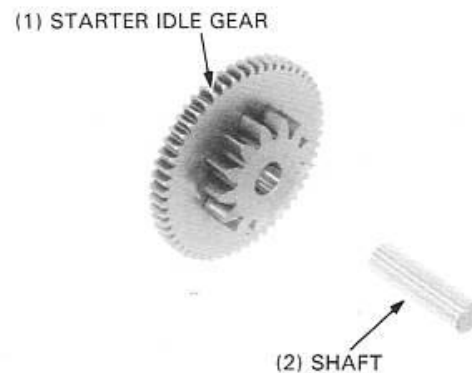

ALTERNATOR/STARTER CLUTCH

Install the starter driven gear onto the one way clutch and check for proper operation by turning the starter driven gear. The starter driven gear should only turn in one direction.

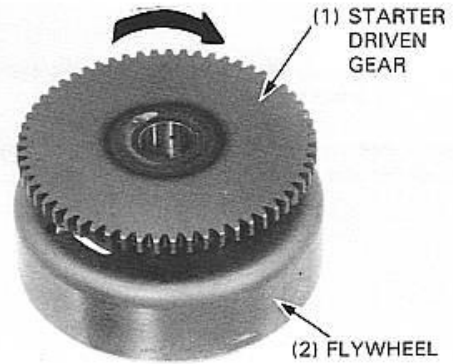

DISASSEMBLY

Remove the three hex socket bolts using an impact driver and 6 mm socket bit.

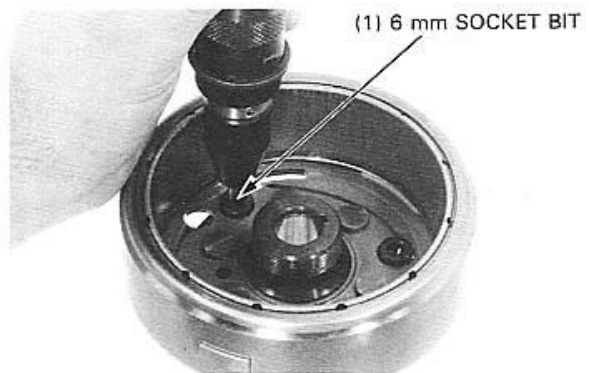

Measure the one way clutch outer I.D.

SERVICE LIMIT: 58.98 mm (2.322 in)

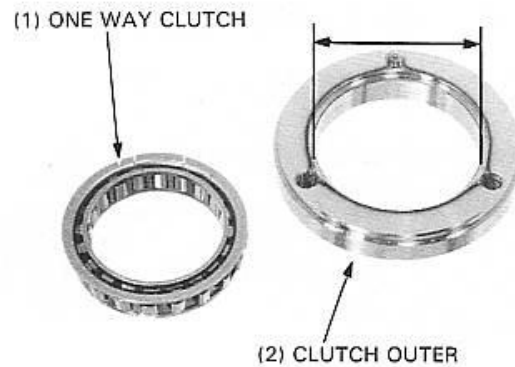

ASSEMBLY

Install the one way clutch into the one way clutch outer.

Install the one way clutch assembly to the flywheel and tighten with 6 mm socket bolts.

TORQUE: 28–32 N·m (2.8–3.2 kg·m, 21–24 ft·lb)

NOTE

- Apply a locking agent to the socket bolt threads.

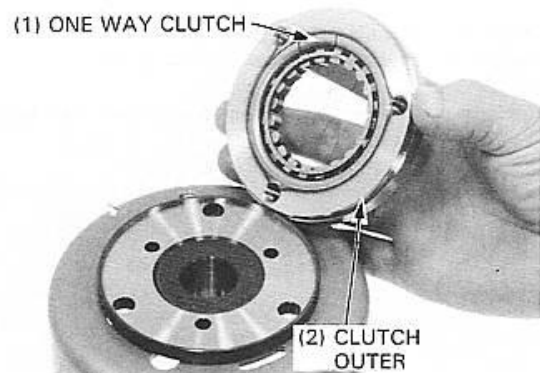

ALTERNATOR/STARTER CLUTCH

INSTALLATION

Install the starter driven gear onto the crankshaft.
Install the set plate and set plate bolt.

Check that the starter driven gear rotates freely.
Install the starter idle gear shaft.

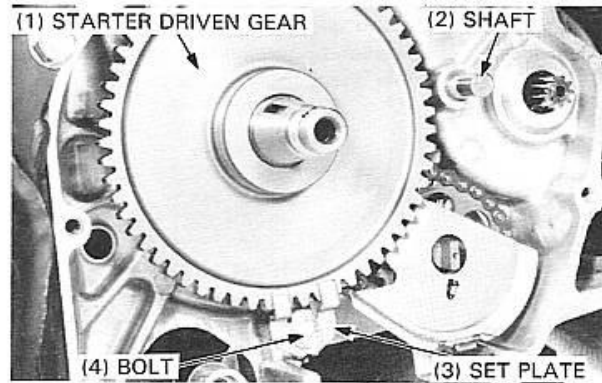

Install the starter idle gear on the shaft.

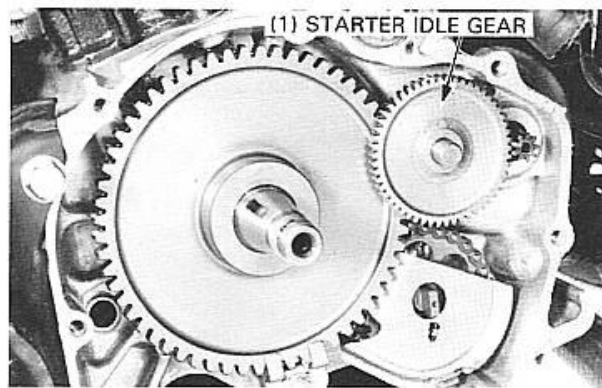

FLYWHEEL INSTALLATION

Wipe off oil and grease from the tapered section of the crankshaft and flywheel.

Install the oil orifice drive pin in the crankshaft.

Install the woodruff key into the crankshaft slot.

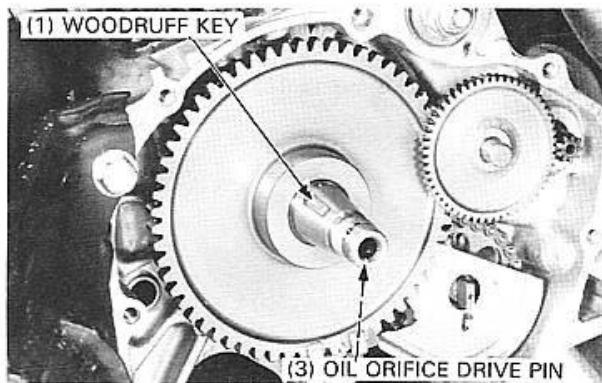

Install the flywheel onto the crankshaft, aligning the key on the crankshaft with the groove in the flywheel.

Apply oil to the washer and install onto the crankshaft.



ALTERNATOR/STARTER CLUTCH

Apply molybdenum disulfide grease to the flywheel nut and crankshaft threads and install and tighten the flywheel nut while holding the flywheel.

TORQUE: 105–115 N·m (10.5–11.5 kg·m, 76–83 ft·lb)

TOOL:

Flywheel holder

07725–0040000 or
equivalent commercially
available in U.S.A.

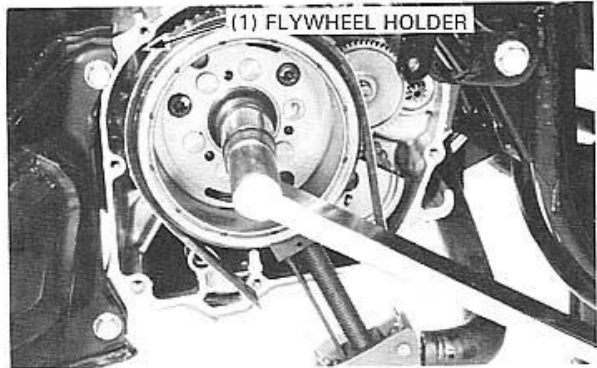

Install the spring and oil orifice onto the crankshaft aligning the slot in the orifice with the drive pin in the crankshaft.

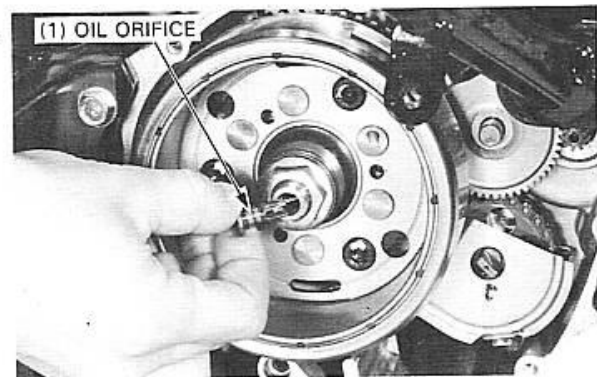

STATOR INSTALLATION

Install the stator on the right crankcase cover with the three bolts.

Install the ignition pulse generator and breather plate with two bolts.

Install the wire grommet in its groove in the cover securely.

NOTE

- Be sure to route the stator wire under the pulse generator.
- Make sure that the breather plate is in position securely.

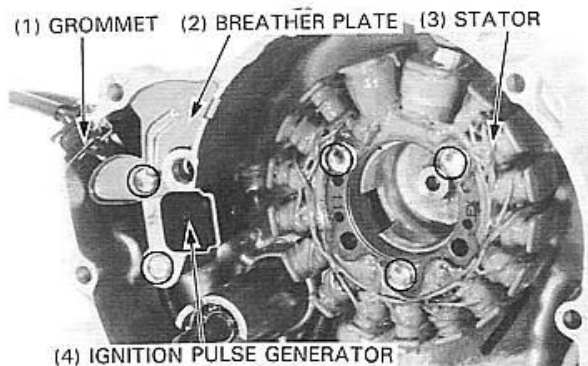

RIGHT CRANKCASE COVER INSTALLATION

Install the dowel pins and a new gasket.

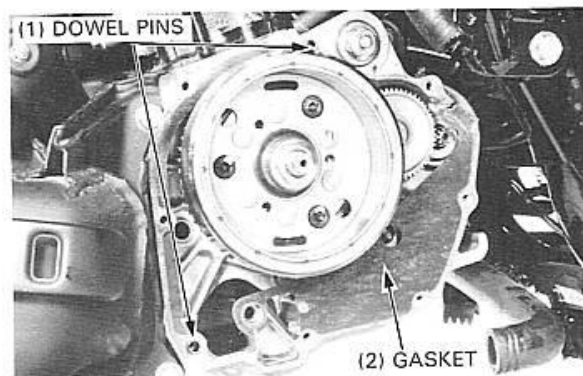

ALTERNATOR/STARTER CLUTCH

Install the right crankcase cover over the crankcase, aligning the water pump shaft groove with the oil pump shaft.

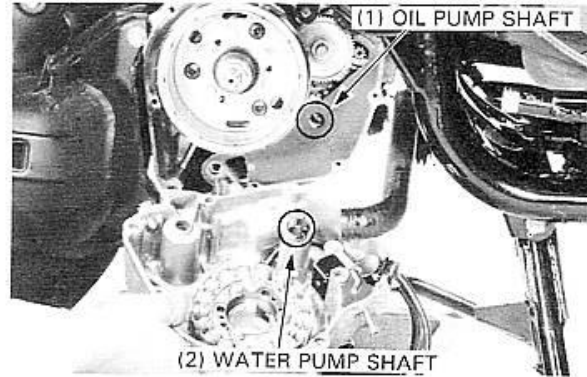

Install the right crankcase cover attaching bolts and tighten them.
Connect the crankcase breather tube to the right crankcase cover.

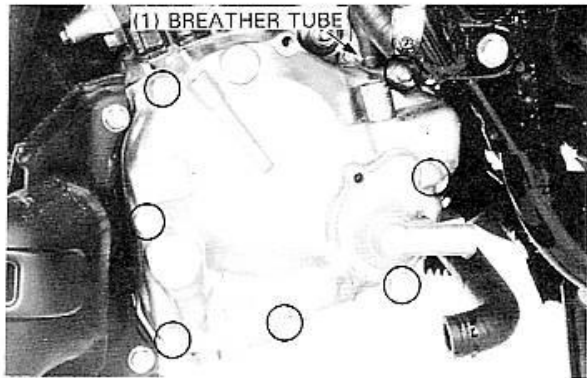

Connect the ignition pulse generator and alternator wire couplers and connectors.

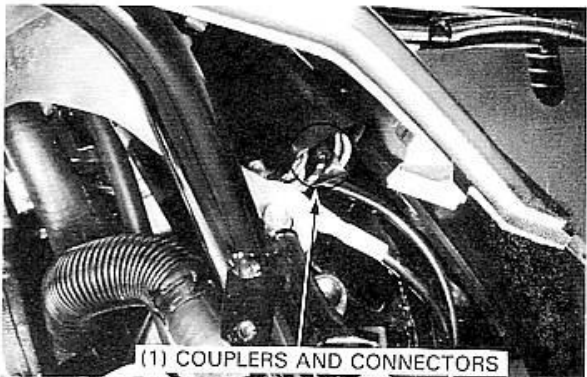

Connect the water hoses to the water pump.

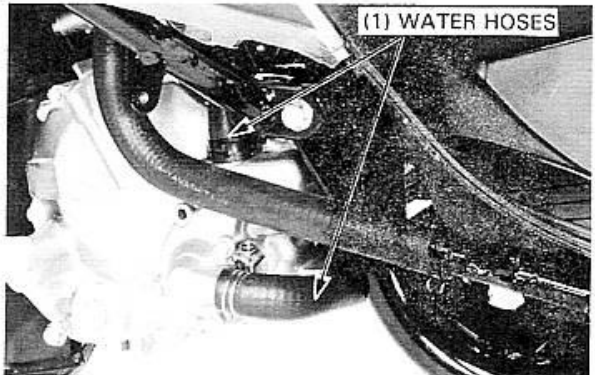

Make sure that the oil pipe is not clogged.
Install the oil pipe with oil bolts and sealing washers.

CAUTION

- The 8 mm oil pipe bolt for the cylinder head cover side is black because its oil hole differs from the oil pipe bolt for the right crankcase cover side.
- Install the oil pipe bolts in the correct position.
- If the 8 mm oil pipe bolts are interchanged, engine damage may result.

NOTE

- Make sure that the sealing washer tab at the right crankcase cover faces the right crankcase side.

Install the oil pipe stay bolts on the right crankcase cover and water pump.

Tighten the 8 mm and 12 mm oil pipe bolts.

TORQUE:

8 mm: 8–12 N·m (0.8–1.2 kg·m, 6–9 ft·lb)

12 mm: 18–22 N·m (1.8–2.2 kg·m, 13–16 ft·lb)

Tighten the oil pipe stay bolts.

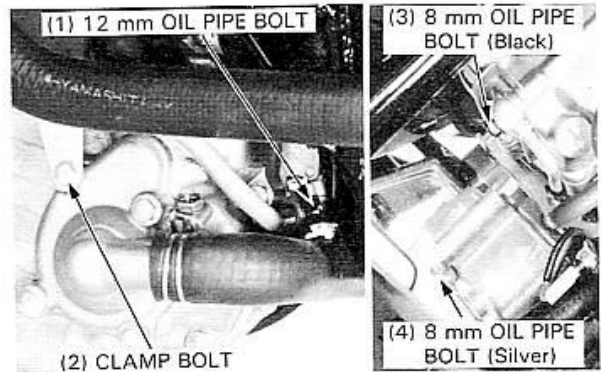

CRANKCASE/CRANKSHAFT

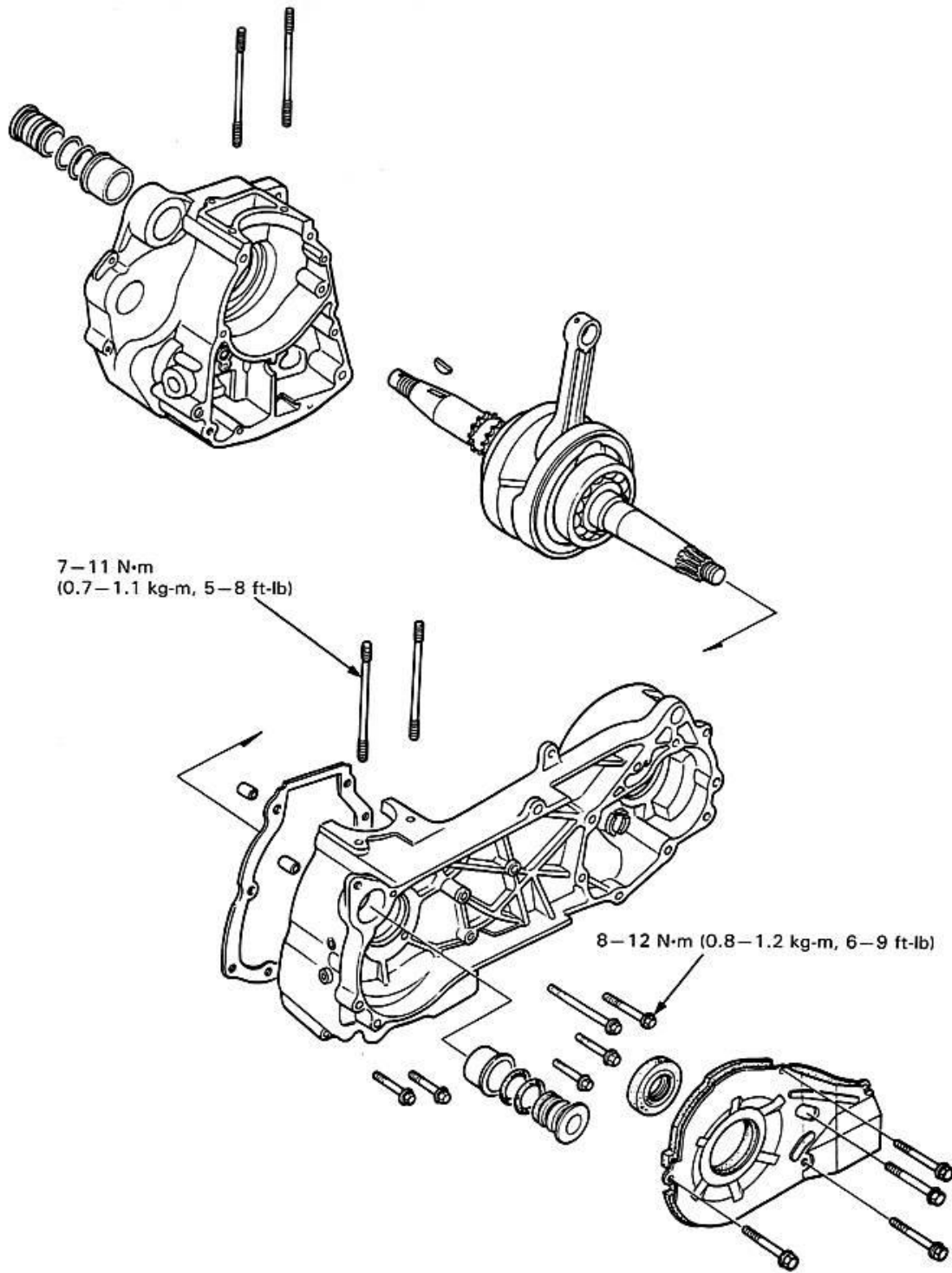

11. CRANKCASE/CRANKSHAFT

SERVICE INFORMATION	11-1	CRANKSHAFT INSPECTION	11-3
TROUBLESHOOTING	11-1	CRANKCASE ASSEMBLY	11-4
CRANKCASE SEPARATION	11-2		

SERVICE INFORMATION

GENERAL

- This section covers crankcase separation to service the crankshaft.
- The following parts must be removed before separating the crankcase.

Engine	Section 5
Cylinder head	Section 6
Cylinder/piston	Section 7
Drive and driven pulleys	Section 8
Alternator/starter driven gear	Section 10
Starter motor	Section 19
- If the crankshaft bearings, oil pump drive sprocket or timing sprocket need replacement, the crankshaft assembly must be replaced.

SPECIFICATIONS

ITEM	STANDARD mm (in)	SERVICE LIMIT mm (in)
Connecting rod big end side clearance	0.05–0.4 (0.002–0.016)	0.6 (0.02)
Connecting rod big end radial clearance	0–0.008 (0–0.0004)	0.05 (0.002)
Crankshaft runout	—	0.10 (0.004)

TORQUE VALUES

Crankcase bolt	8–12 N·m (0.8–1.2 kg·m, 6–9 ft·lb)
Cylinder stud bolt	7–11 N·m (0.7–1.1 kg·m, 5–8 ft·lb)

TROUBLESHOOTING

Excessive engine noise

- Excessive bearing play
- Excessive crankpin bearing play
- Worn piston pin and piston pin hole

CRANKCASE/CRANKSHAFT

CRANKCASE SEPARATION

Remove the cam chain adjuster slipper by removing the bolt.
Remove the cam chain.

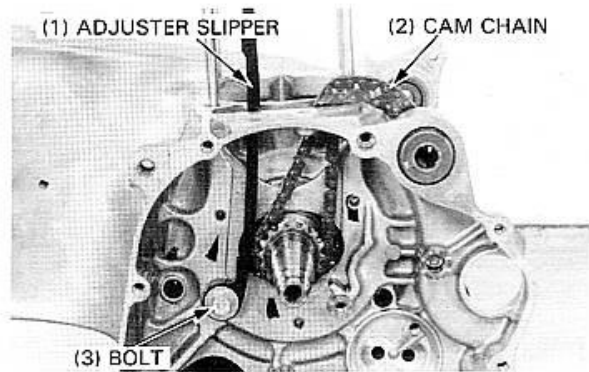

Remove the nine crankcase attaching bolts and heat insulator.

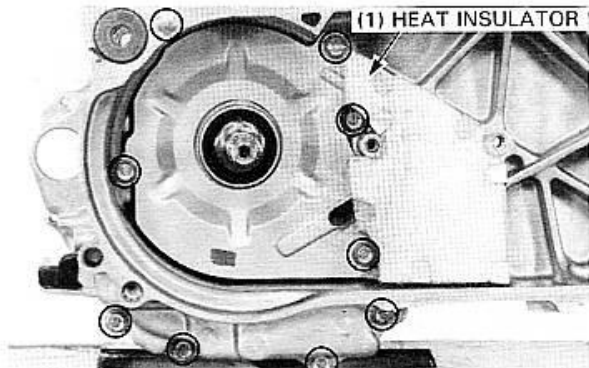

Place the crankcase with the left side crankcase down and remove the right crankcase.

CAUTION

- *Never pry the crankcase mating surfaces apart.*

Remove the gasket and dowel pins.

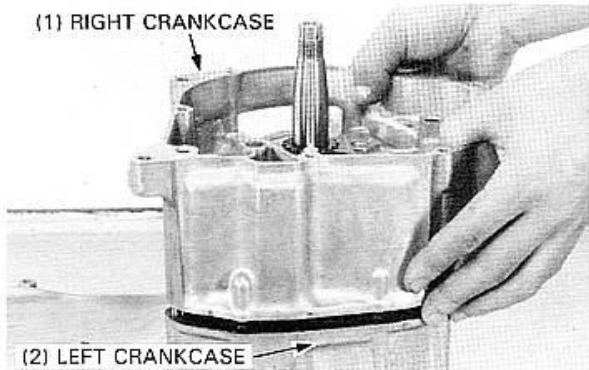

Remove the crankshaft from the left crankcase.

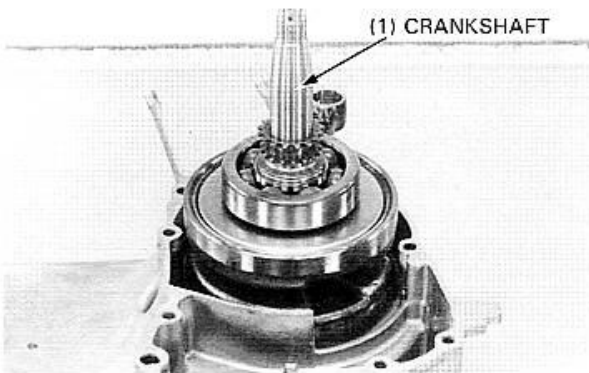

Remove the oil pipe from the right crankcase by removing the bolt.

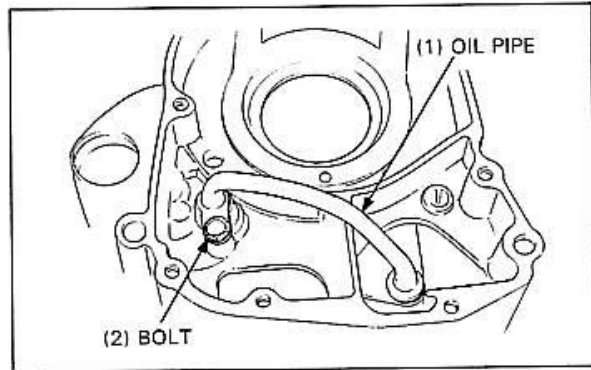

Check the oil seal for wear or damage.
Replace the oil seal if necessary.

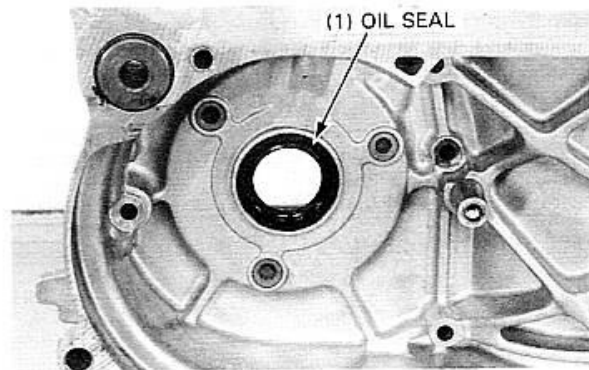

CRANKSHAFT INSPECTION

Measure the connecting rod big end side clearance with a feeler gauge.

SERVICE LIMIT: 0.6 mm (0.02 in)

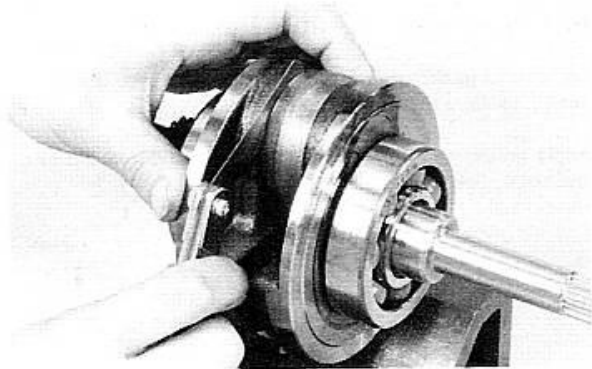

Measure the connecting rod big end radial clearance in two places at right angles to the crankshaft.

SERVICE LIMIT: 0.05 mm (0.002 in)

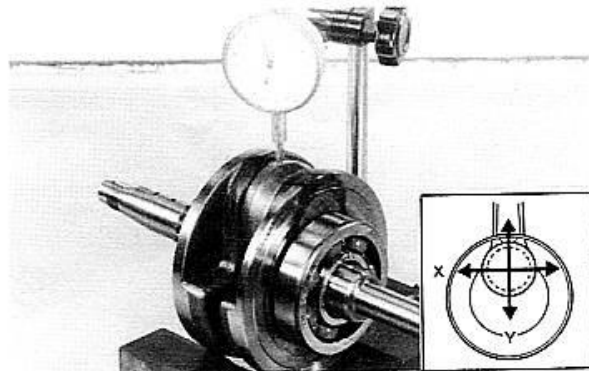

CRANKCASE/CRANKSHAFT

Set the crankshaft on a stand or in V blocks and read runout at the points shown, using a dial indicator

SERVICE LIMIT: 0.10 mm (0.004 in)

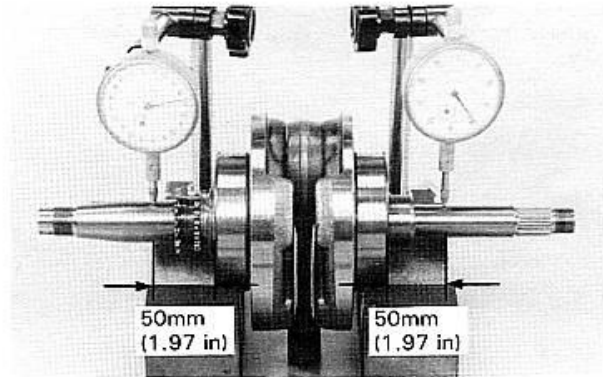

Turn the outer race of each bearing with your finger. The bearings should turn smoothly and quietly. Also check that the bearing inner race fits tightly in the crankshaft.

Replace the crankshaft assembly if the races do not turn smoothly, quietly, or if they fit loosely in the crankshaft.

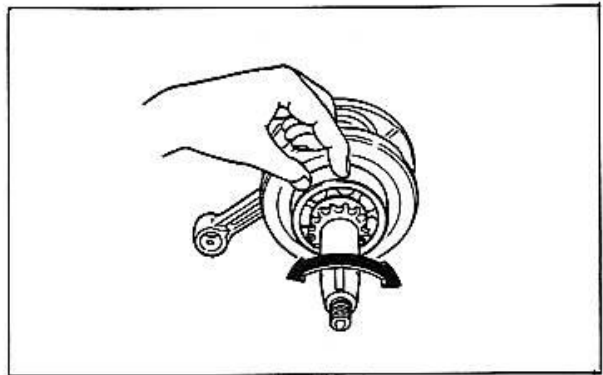

CRANKCASE ASSEMBLY

Remove all gasket materials from the crankcase being careful not to damage the mating surfaces.

Apply grease to the lip of a new oil seal and install it into the left crankcase.

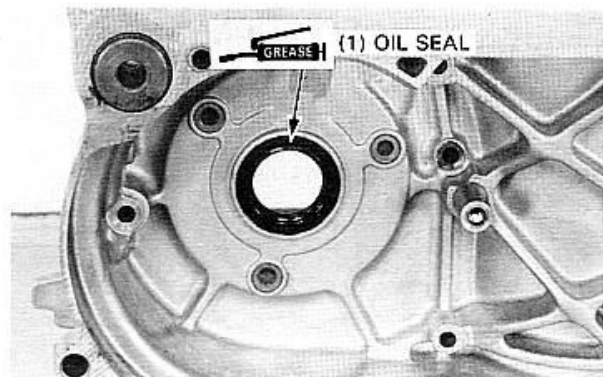

Wash the oil pipe in clean solvent and install new oil seals on both ends of the pipe.

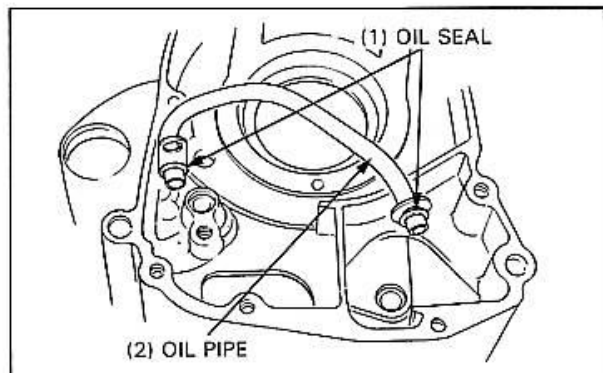

CRANKCASE/CRANKSHAFT

Install the oil pipe into the right crankcase and secure it with the bolt.

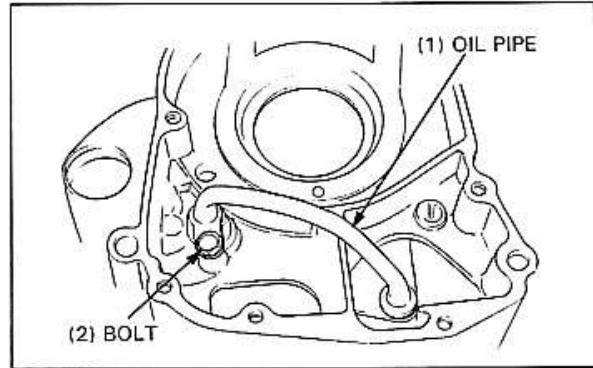

Install the crankshaft into the left crankcase being careful not to damage the oil seal.

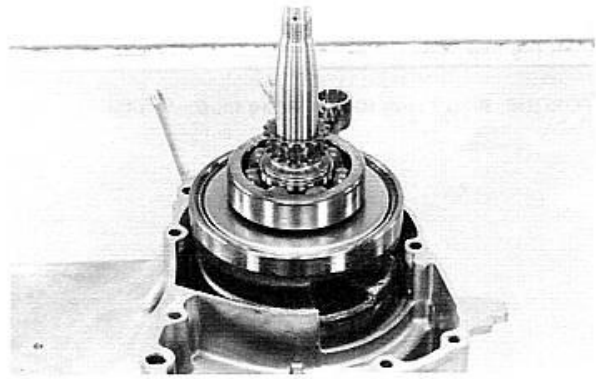

Install the dowel pins and a new gasket.

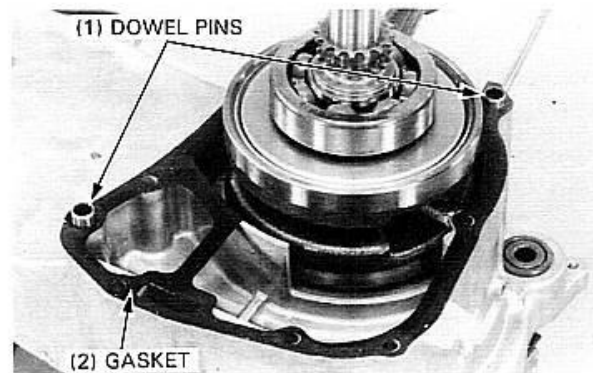

Place the right crankcase over the crankshaft and onto the left crankcase.

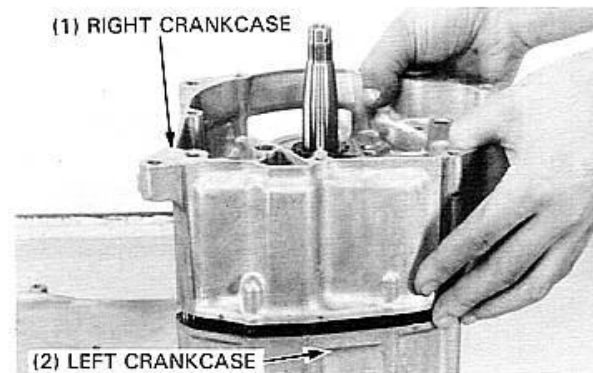

CRANKCASE/CRANKSHAFT

Install the heat insulator and the nine crankcase attaching bolts.

TORQUE: 8–12 N·m (0.8–1.2 kg-m, 6–9 ft-lb)

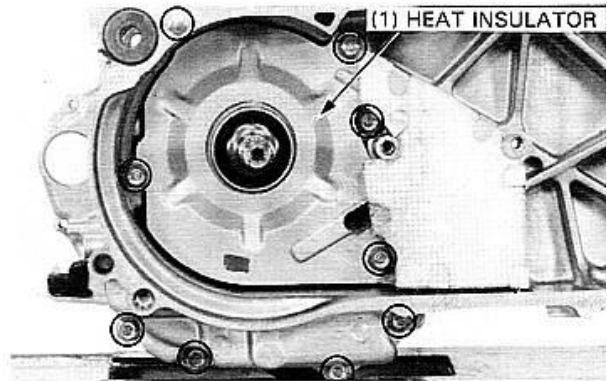

Install the cam chain, cam chain adjuster slipper and secure it with the bolt.

TORQUE: 8–12 N·m (0.8–1.2 kg-m, 6–9 ft-lb)

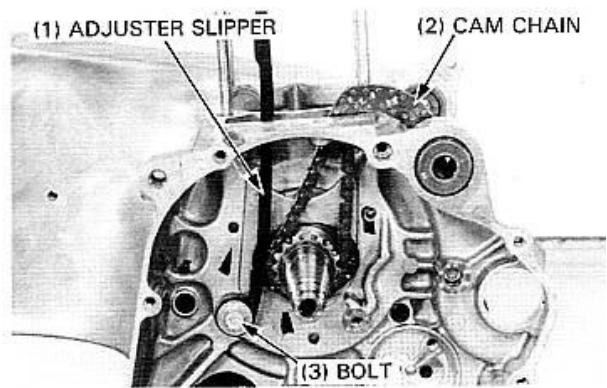

11-6

Last page of Chapter 11

COOLING SYSTEM

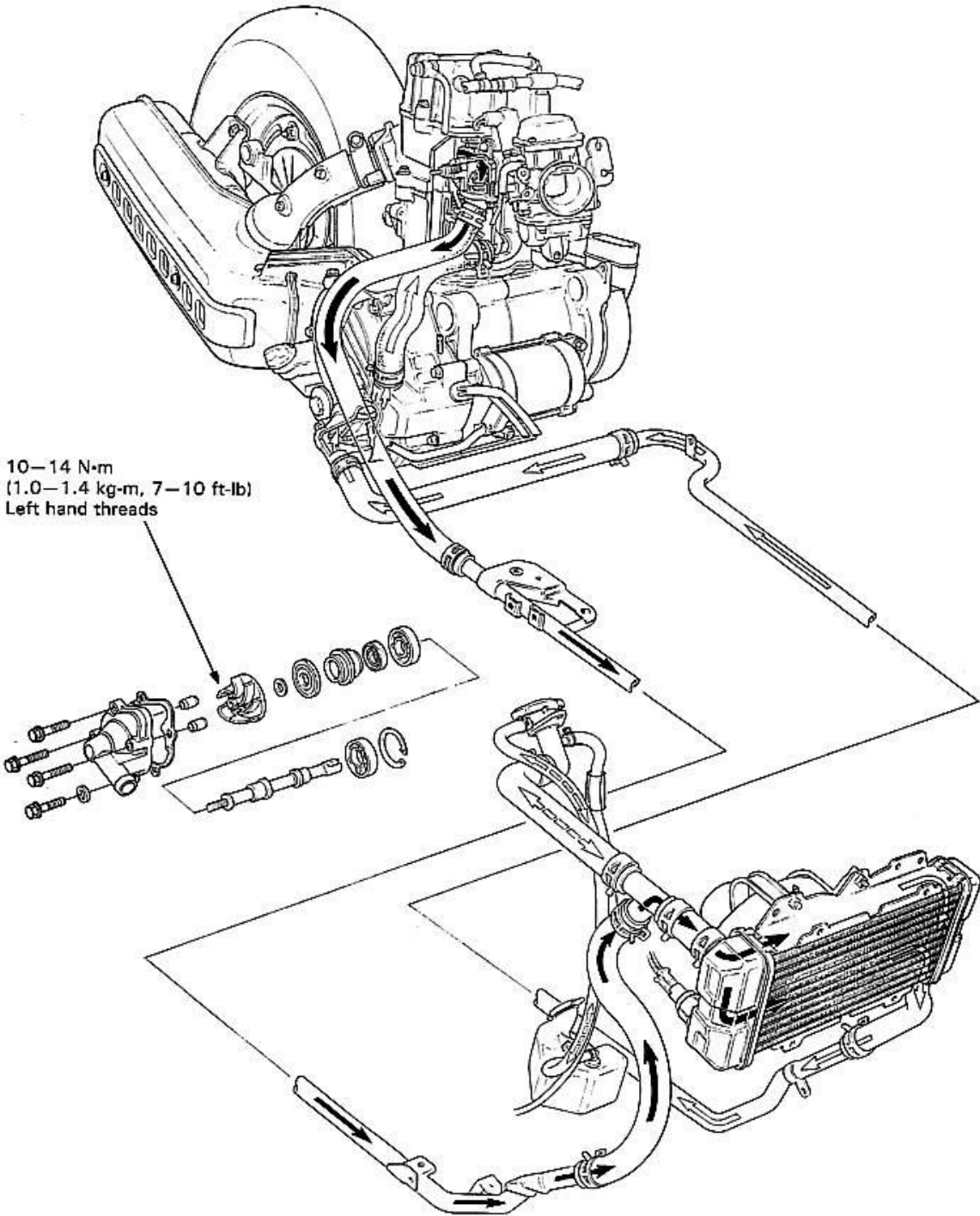

12. COOLING SYSTEM

SERVICE INFORMATION	12-1	RADIATOR	12-4
TROUBLESHOOTING	12-2	WATER PUMP	12-6
SYSTEM TESTING	12-3	THERMOSTAT	12-9
COOLANT REPLACEMENT	12-3	THERMOSENSOR	12-11

SERVICE INFORMATION

Click the topic or page above
to go there ==>

GENERAL

WARNING

- *Do not remove the radiator cap when the engine is hot. The coolant is under pressure and severe scalding could result. The engine must be cool before servicing the cooling system.*
- Use only distilled water and ethylene glycol in the cooling system. A 50–50 mixture is recommended for maximum corrosion protection. Do not use alcohol-based antifreeze.
- Add coolant at the reserve tank. Do not remove the radiator cap except to refill or drain the system.
- The cooling system service can be done with the engine in the frame.
- Avoid spilling coolant on painted surfaces.
- After servicing the system, check for leaks with a cooling system tester.
- Refer to section 17 for fan motor thermostatic switch and temperature gauge inspections.

SPECIFICATIONS

Radiator cap relief pressure	75–105 kPa (0.75–1.05 kg/cm ² , 10.7–14.9 psi)
Freezing point (Hydrometer test)	55 % distilled water + 45 % ethylene glycol: – 32°C (– 26°F) 50 % distilled water + 50 % ethylene glycol: – 37°C (– 35°F) 45 % distilled water + 55 % ethylene glycol: – 44.5°C (– 48°F)
Coolant capacity: Radiator and engine Reserve tank Total system	1.42 liter (1.50 US qt, 1.25 Imp qt) 0.40 liter (0.42 US qt, 0.35 Imp qt) 1.82 liter (1.93 US qt, 1.60 Imp qt)
Thermostat	Begins to open: 69.5°C to 72.5°C (157°F to 162°F) Valve lift: 3.5–4.5 mm (0.14–0.18 in) at 80°C (176°F)
Boiling point (with 50–50 mixture)	Unpressurized: 107.7°C (226°F) Cap on, pressurized: 125.6°C (258°F)

TORQUE VALUES

Water pump impeller (left hand threads)	10–14 N·m (1.0–1.4 kg-m, 7–10 ft-lb)
Oil pipe bolt 8 mm	8–12 N·m (0.8–1.2 kg-m, 6–9 ft-lb)
12 mm	18–22 N·m (1.8–2.2 kg-m, 13–16 ft-lb)

TOOLS

Special

Mechanical seal	07945–4150400 or GN-AH-065-415 (U.S.A. only)
Bearing remover set, 15 mm	07936–KC10000
– Bearing remover, 15 mm	07936–KC10500
(Remover shaft, 15 mm)	07936–KC10100)
(Remover head, 15 mm)	07936–KC10200)
– Remover weight	07741–0010201 or 07936–3710200
Attachment, 28 x 30 mm	07946–1870100

Common

Remover weight	07741–0010200
Driver	07749–0010000

COOLING SYSTEM

TROUBLESHOOTING

Engine temperature too high

- Faulty temperature gauge or gauge sensor
- Faulty radiator cap
- Thermostat stuck closed
- Insufficient coolant
- Passages blocked in radiator, hoses or water jacket
- Faulty water pump
- Faulty fan motor

Engine temperature too low

- Faulty temperature gauge or gauge sensor
- Thermostat stuck open

Coolant leaks

- Faulty pump mechanical seal
- Deteriorated O-rings
- Damaged or deteriorated hoses

12-2

Nothing else on this page.

SYSTEM TESTING

COOLANT

Remove the reserve tank lid and reserve tank cap.
 Test coolant mixture with an antifreeze tester.
 For maximum corrosion protection, a 50–50% solution of ethylene glycol and distilled water is recommended.

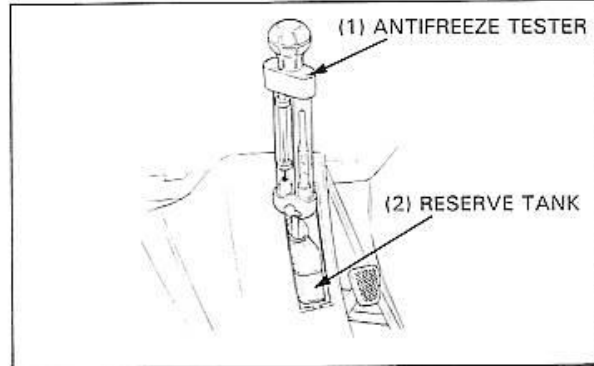

RADIATOR CAP INSPECTION

WARNING

- *The engine must be cool before removing the radiator cap, or severe scalding may result.*

Wet the cap sealing surface and pressure test the radiator cap. Replace the radiator cap if it does not hold pressure or if relief pressure is too high or low. It must hold the specified pressure for at least six seconds.

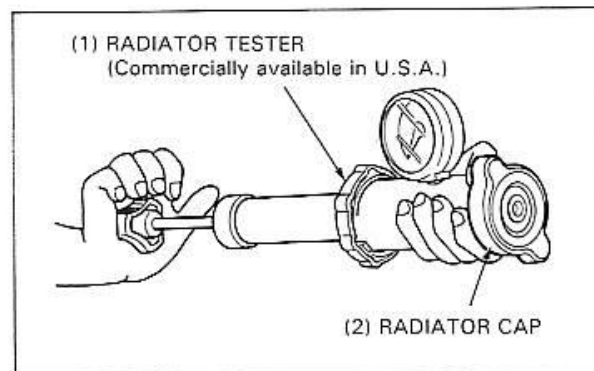

RADIATOR CAP RELIEF PRESSURE:

75–105 kPa (0.75–1.05 kg/cm², 10.7–14.9 psi)

Pressurize the radiator, engine and hoses, and check for leaks.

CAUTION

- *Excessive pressure can damage the radiator. Do not exceed 1.05 kg/cm² (14.9 Psi)*

Repair or replace components if the system will not hold the specified pressure for at least six seconds.

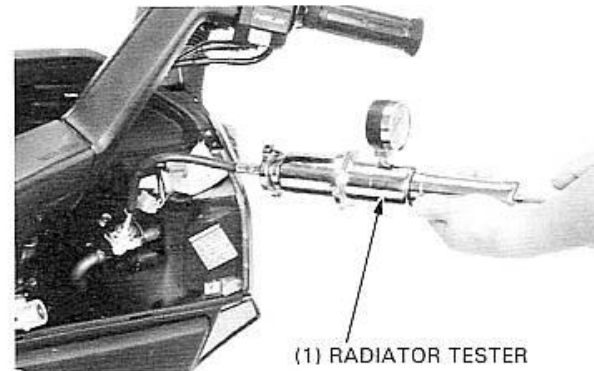

COOLANT REPLACEMENT

WARNING

- *The engine must be cool before servicing the cooling system, or severe scalding may result.*

Remove the maintenance cover (page 13-4).
 Remove the radiator cap.

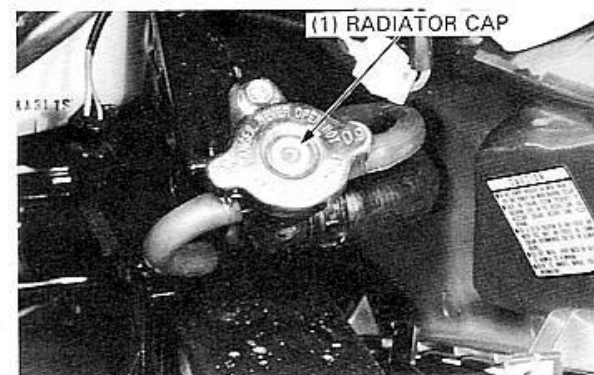

COOLING SYSTEM

Place a drain pan under the water pump and drain the coolant from the system by removing the drain bolt.

Reinstall the drain bolt.

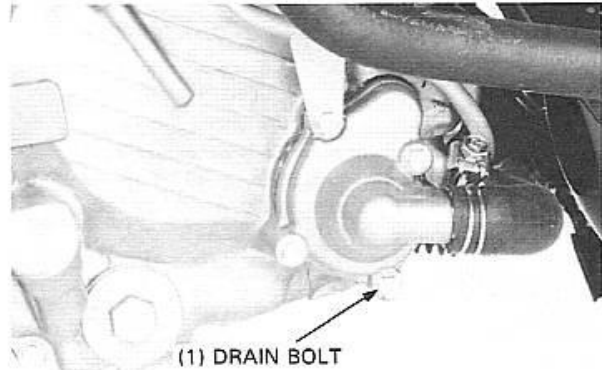

Fill the system with a 50—50 mixture of distilled water and ethylene glycol.

CAPACITY: 1.42 f (1.50 US qt, 1.25 Imp qt)

Bleed air from the system.

- Start the engine and run until there are no air bubbles in the coolant, and the level stabilizes.
- Stop the engine and add coolant up to the proper level if necessary.
- Reinstall the radiator cap.
- Check the level of coolant in the reserve tank and fill to the correct level if the level is low. Install the maintenance cover.

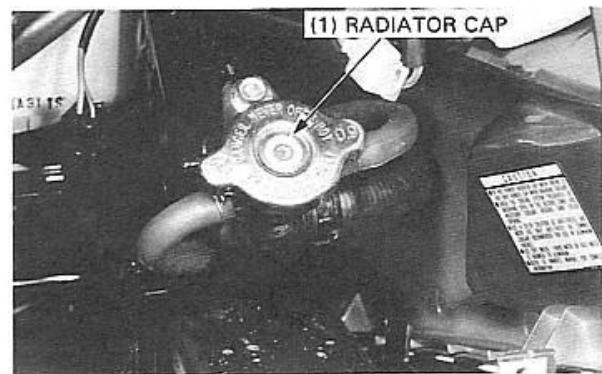

RADIATOR

Remove the front upper cover (page 13-7).

Inspect the radiator soldered joints and seams for leaks.

Blow dirt out from between core fins with low pressure air. If insects etc., are clogging the radiator, wash them off with low pressure water.

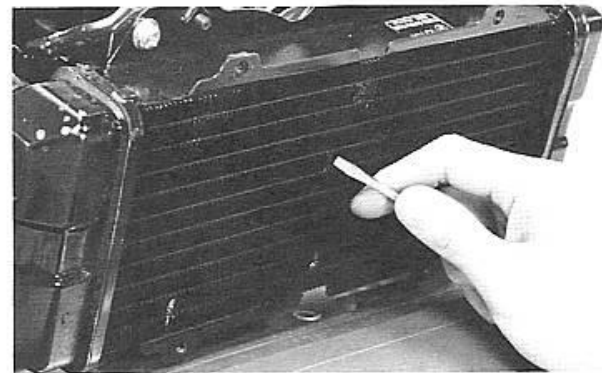

REMOVAL/INSTALLATION

Drain the coolant (page 12-3).

Remove the front upper cover (page 13-7).

Remove the radiator grill by removing the four screws.

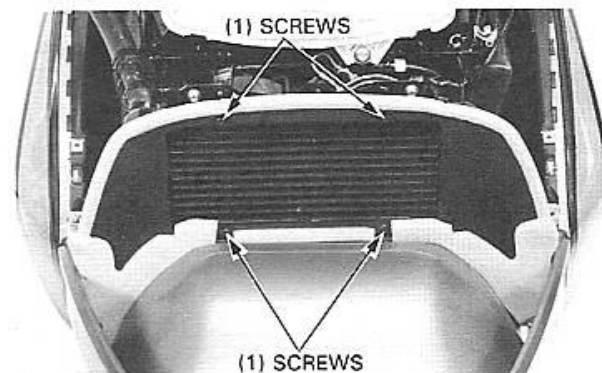

Disconnect the radiator upper and lower hoses from the radiator.
Disconnect the thermoswitch wires.
Remove the four radiator mounting screws and radiator.

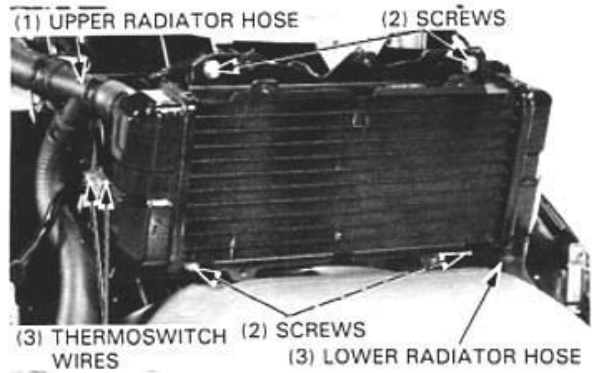

DISASSEMBLY/ASSEMBLY

Remove the fan shroud with the fan motor by removing the three bolts.

Remove the cooling fan from the fan motor by removing the nut.

Remove the fan motor from the shroud by removing the bolts.

Assemble in the reverse order of removal.

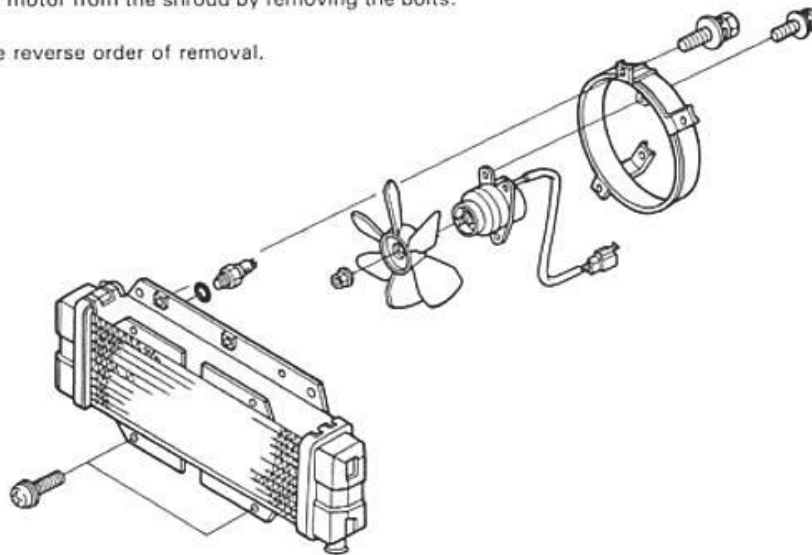

INSTALLATION

Install the radiator in the reverse order of removal.
Fill and bleed the cooling system (page 12-3).

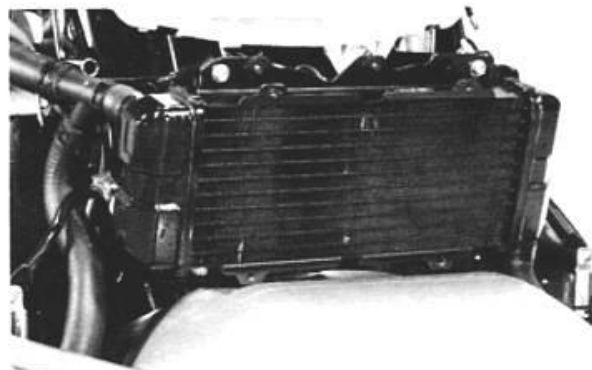

COOLING SYSTEM

WATER PUMP

MECHANICAL SEAL INSPECTION

Inspect the telltale hole for signs of coolant leakage.
If the mechanical seal is leaking, remove the right crankcase cover and replace the mechanical seal.

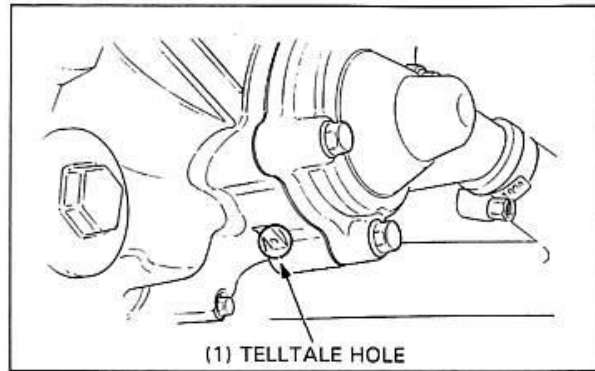

WATER PUMP REMOVAL

Drain the coolant (page 12-3).
Drain the engine oil (page 2-2).
Remove the oil pipe (page 10-2).
Remove the right rear cover (page 13-2).
Disconnect the water hose from the water pump.

Remove the water pump cover by removing the three bolts.

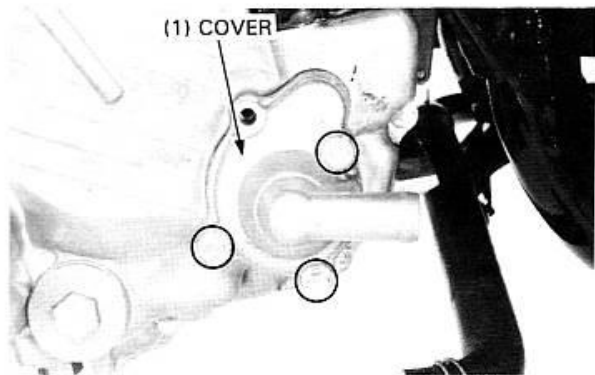

Remove the dowel pins and gasket.

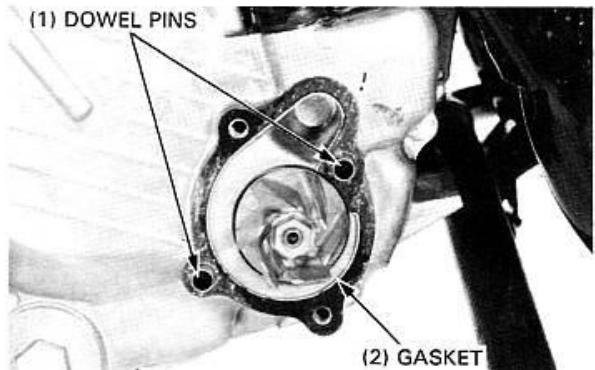

Remove the water pump impeller by turning it clockwise.

NOTE

- The impeller has left hand threads.

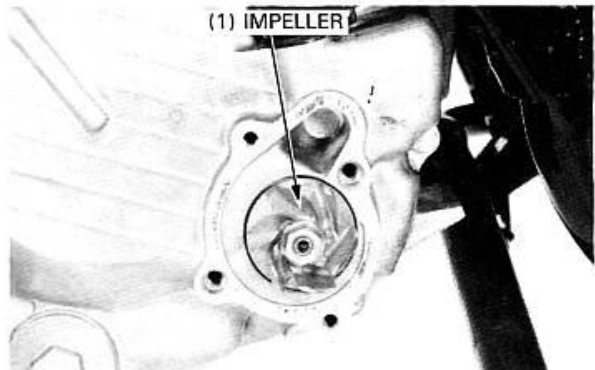

Inspect the mechanical seal and seal washer for wear or damage.

NOTE

- The mechanical seal and seal washer must be replaced as a set.

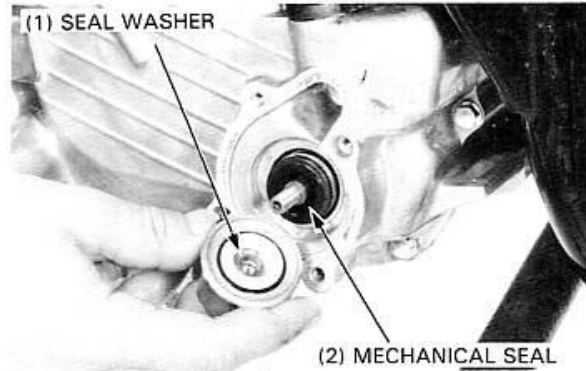

WATER PUMP SHAFT REMOVAL

Remove the right crankcase cover (page 10-2).

Remove the snap ring from the right crankcase cover.
Remove the water pump shaft.

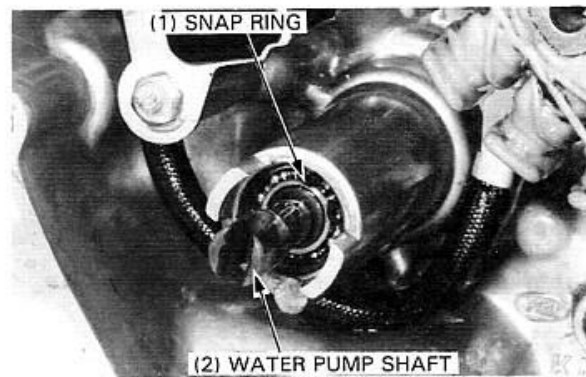

Turn the water pump bearing outer races with your finger.
The races should turn smoothly and quietly.
Replace if necessary.

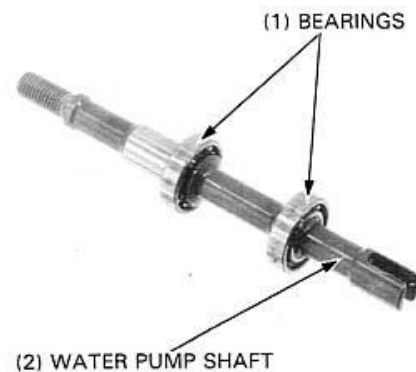

MECHANICAL SEAL REPLACEMENT

Remove the mechanical seal and oil seal out of the right crankcase cover using a bearing remover.

Tools:

- | | |
|----------------------------|------------------|
| Bearing remover set, 15 mm | 07936-KC10000 or |
| — Bearing remover, 15 mm | 07936-KC10500 |
| (Remover shaft, 15 mm | 07936-KC10100) |
| (Remover head, 15 mm | 07936-KC10200) |
| — Remover weight | 07741-0010201 or |
| | 07936-3710200 |

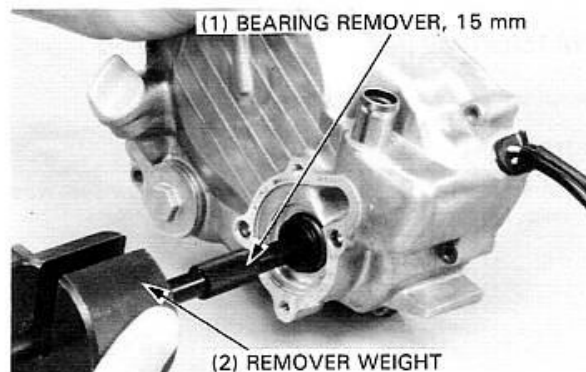

COOLING SYSTEM

Drive a new oil seal into the cover with the oil seal marks facing out.

TOOLS:

Attachment, 28 x 30 mm 07946-1870100
Driver 07749-0010000

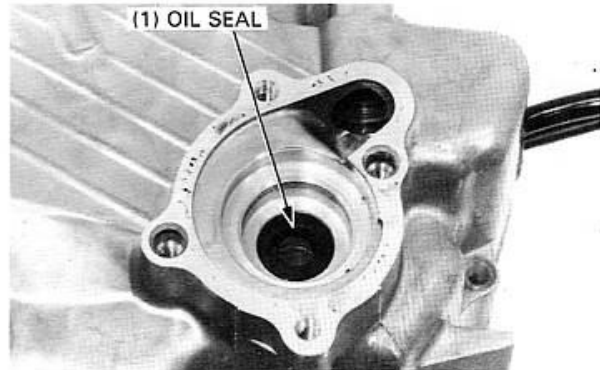

Apply sealant to the outer surface of a new mechanical seal.
Drive the new seal into the cover.

TOOLS:

Driver 07749-0010000
Mechanical seal driver attachment 07945-4150400 or
 GN-AH-065-415
Mechanical seal installer U.S.A. only
(Use installer cup in conjunction with hydraulic press.)

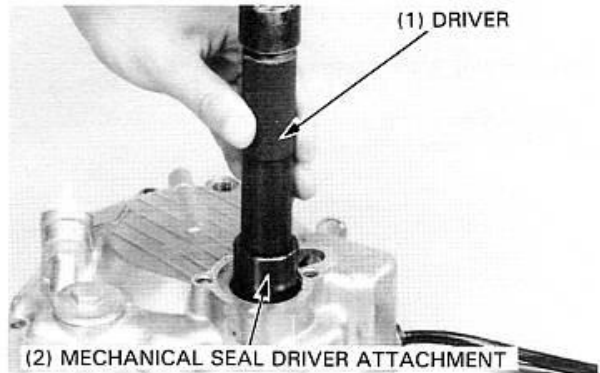

WATER PUMP SHAFT INSTALLATION

Install the water pump shaft into the right crankcase.
Install the snap ring into the ring groove to secure the bearing.

Install the right crankcase cover (page 10-7).

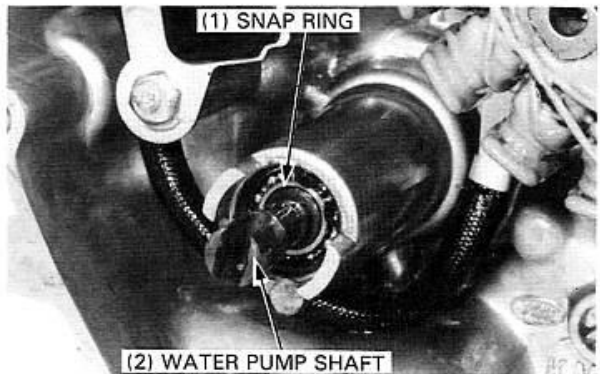

WATER PUMP IMPELLER INSTALLATION

Install the seal washer into the impeller.

NOTE

- When the mechanical seal is replaced, a new seal washer must be used.

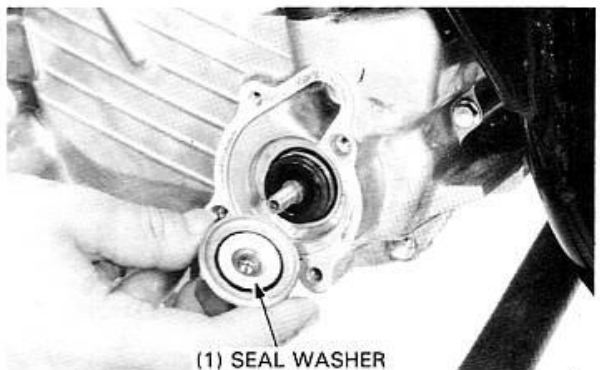

Install the impeller onto the pump shaft and tighten it.

TORQUE: 10–14 N·m (1.0–1.4 kg-m, 7–10 ft-lb)

NOTE

- The impeller has left hand threads.

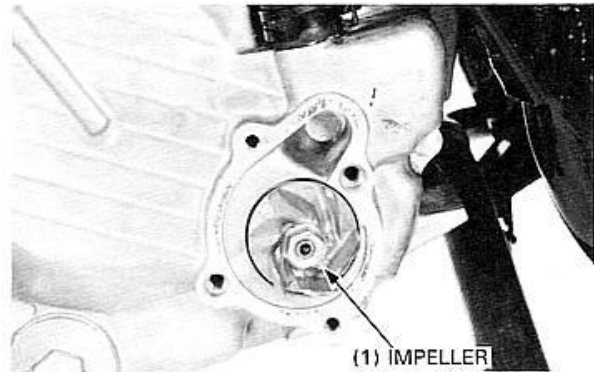

Install the dowel pins and a new gasket.

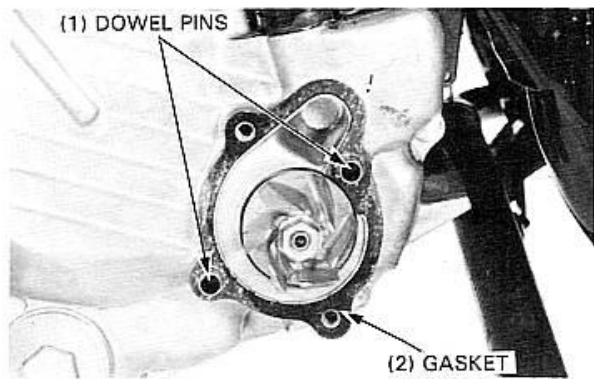

Install the water pump cover with the three bolts.

Install the oil pipe (page 10-9).
 Connect the water hoses to the water pump.
 Fill the crankcase with the recommended oil (page 2-1).
 Fill the cooling system (page 12-3).

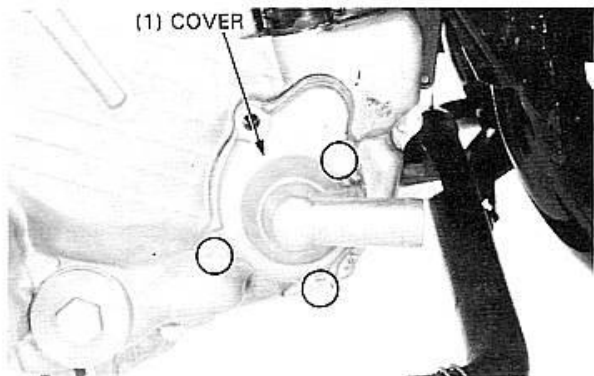

THERMOSTAT

REMOVAL

Remove the seat (page 13-2).
 Disconnect the thermosensor wire connector from the housing.
 Drain the coolant (page 12-3).

Remove the thermostat housing from the cylinder head by removing the mounting bolt.

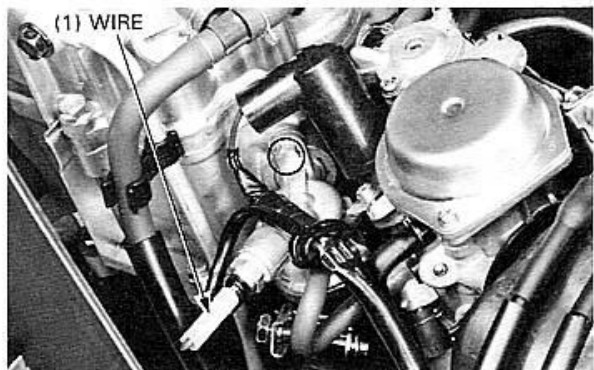

COOLING SYSTEM

Remove the cover attaching bolts and separate the thermostat housing.

Remove the O-ring from the thermostat housing.

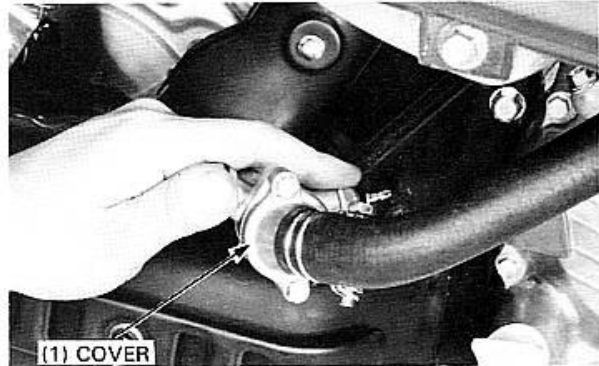

Remove the thermostat from the housing.

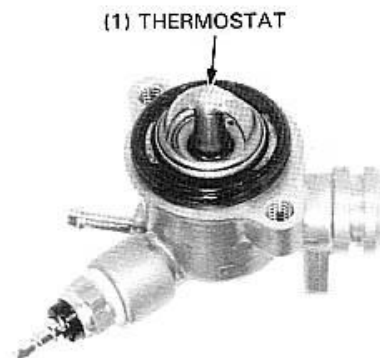

INSPECTION

Inspect the thermostat visually for damage.
Suspend the thermostat in heated water to check its operation.

NOTE

- If the thermostat or thermometer touches the pan, you'll get a false reading.

Replace the thermostat if the valve stays open at room temperature, or if it responds at temperatures other than those specified.

Technical Data

Start to open	80° to 90°C (176° to 194°F)
Fully open	3.5–4.5 mm (0.14–0.18 in) when heated to 90°C (194°F) for 5 minutes.

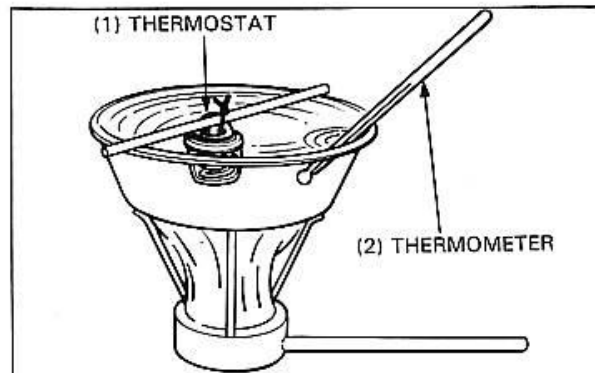

INSTALLATION

Install in the reverse order of removal.

NOTE

- Replace the O-ring with a new one and apply grease to it.

Tighten the thermostat housing mounting bolt.
Fill the cooling system with the specified coolant (page 12-3).

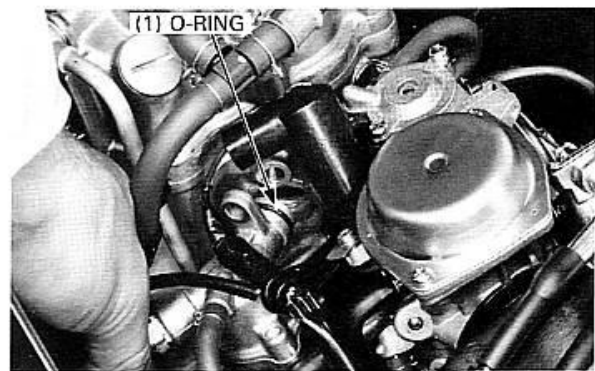

THERMOSENSOR

REMOVAL

Remove the seat.
Drain the coolant (page 12-3).
Disconnect the thermosensor wire.
Remove the thermosensor.

INSTALLATION

Apply 3-BOND No. 1211 sealant or equivalent to the thermosensor threads and install it into the thermostat housing.
Connect the thermosensor wire.
Fill and bleed the cooling system (page 12-3).
Install the seat.

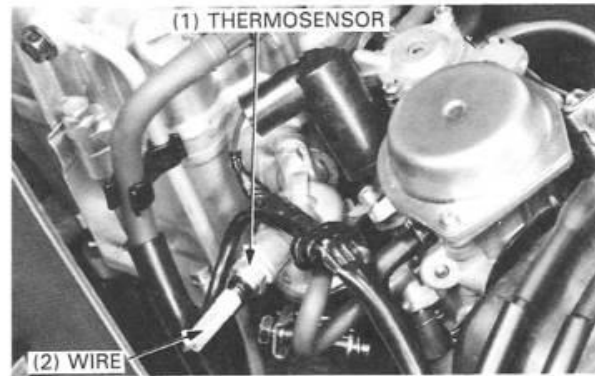

12-11

End of Section 12

13. FRAME COVERS/REAR FRAME

SERVICE INFORMATION	13-1	SIDE RAIL	13-5
SEAT	13-2	FLOOR MAT/FOOT PEG	13-5
REAR COVER	13-2	FRONT LOWER COVER	13-6
TRUNK COVER	13-3	FRONT UPPER COVER	13-7
TRUNK HOOD	13-3	FLOOR PANEL	13-8
TRUNK	13-4	INNER BOX	13-8
MAINTENANCE COVER	13-4	REAR FRAME	13-9
BODY CENTER COVER	13-5		

SERVICE INFORMATION

GENERAL

- This section includes the frame covers (right and left rear cover, trunk cover, trunk hood, trunk, maintenance cover, body center cover, side rail, floor mat/foot peg, front lower cover front upper cover, floor panel, inner box and rear frame) maintenance.
- Release the tabs from the groove when removing the cover.

COVER NAME	MAINTENACE ITEM	COVER NAME	MAINTENANCE ITEM
SEAT	Battery Rear shock absorber Carburetor Muffler Thermostat	MAINTENANCE COVER	Handlebar Electrical parts —bulb replacement —handlebar switch —horn
SEAT AND REAR COVER	Cylinder head Camshaft Cylinder/piston	FRONT UPPER COVER	Radiator Headlight
LEFT REAR COVER	Air cleaner Drive belt air cleaner Drive belt, Drive pulley, Driven pulley/Clutch Final reduction	INSTRUMENT PANEL REAR FRAME	Instruments Engine removal
RIGHT REAR COVER	Water pump Oil pump Flywheel Starter clutch Alternator	FRONT LOWER COVER	Parking brake lock
FLOOR PANEL	Fuel tank Rear brake pedal	FORK FENDER	Steering stem

13

FRAME COVERS/REAR FRAME

SEAT

Remove the seat mounting bolt and remove the seat.

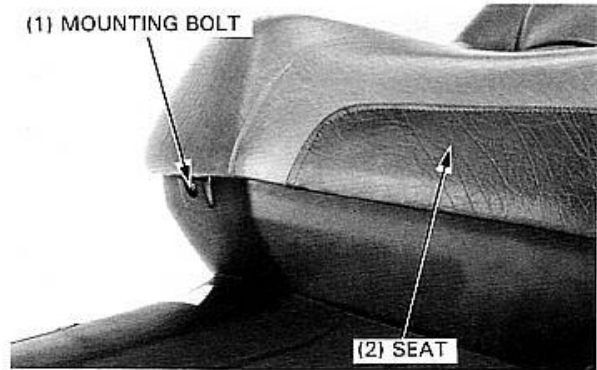

REAR COVER

Remove the four screws attaching the rear cover.
Open the rear trunk.
Take off the rear cover from the rear mud guard, then unhook the tab from the trunk cover.
Take off the rear cover tab from the floor plate by pushing down the floor plate.
Pull out the rear cover from the grommet in the floor panel.

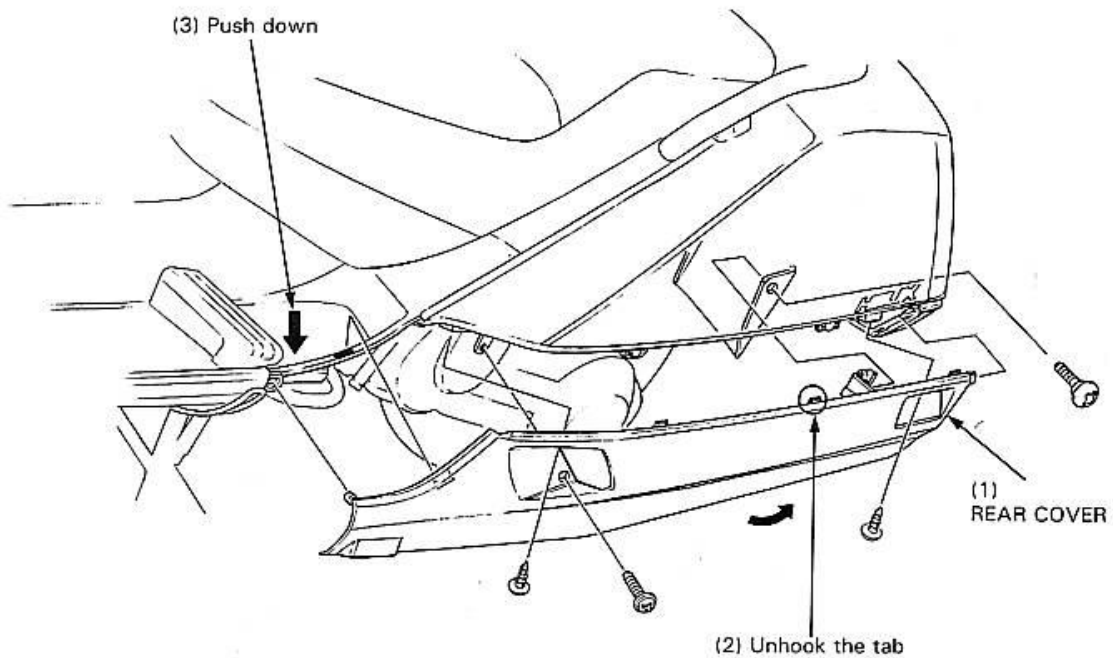
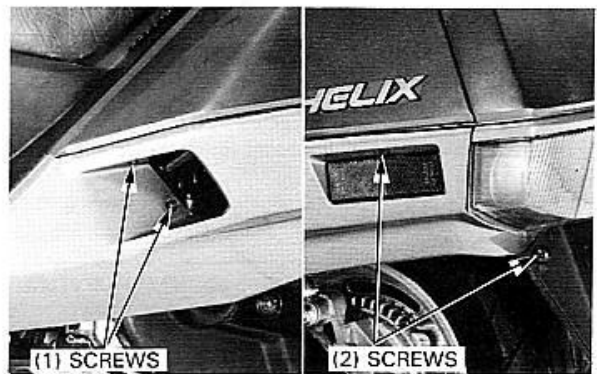

TRUNK COVER

Remove the seat (page 13-2).
 Remove the grab rails by removing the four bolts.
 Remove the right and left rear covers (page 13-2).

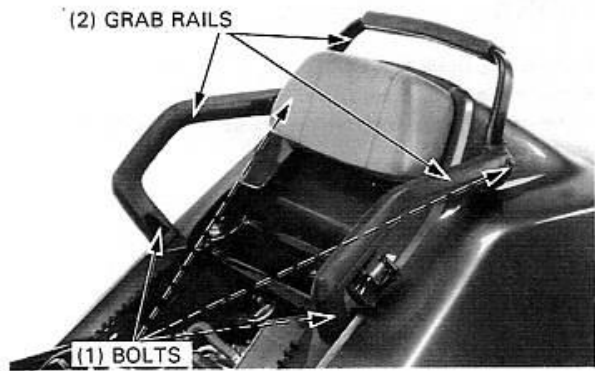

Remove the helmet holder by removing the attaching bolt.

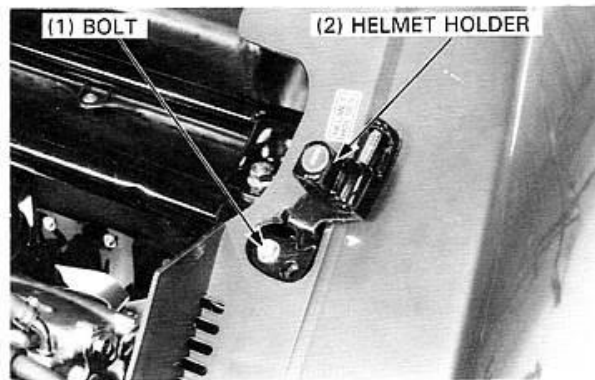

Remove the four trunk mounting bolts and trunk cover.



TRUNK HOOD

Unhook the trunk hood wire from the trunk hood.
 Remove the two trunk hood mounting bolts and hood.

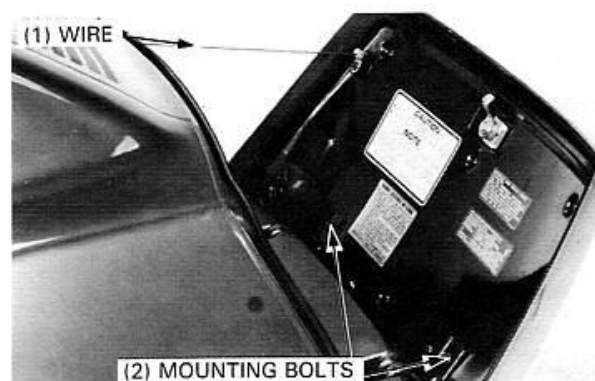

FRAME COVERS/REAR FRAME

TRUNK

Unhook the trunk hood wire.
Remove the trunk tray.
Remove the seat, rear covers (page 13-2) and trunk cover (page 13-3).

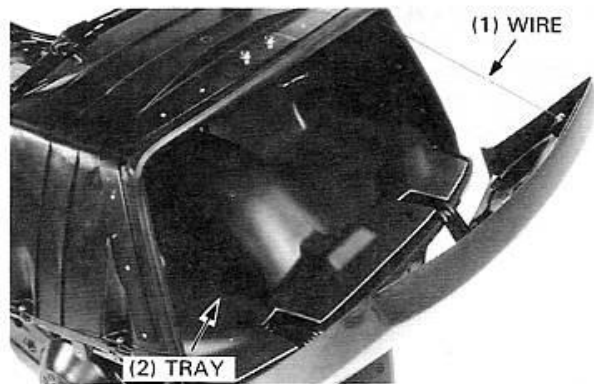

Remove the four trunk attaching screws and trunk.

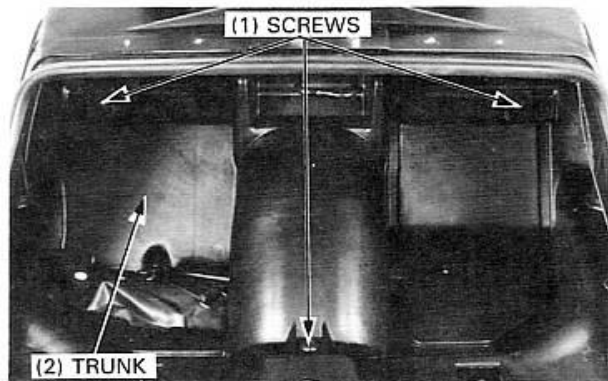

MAINTENANCE COVER

Remove the three maintenance cover attaching screws.
Release the tabs on the maintenance cover from the slots in the front cover.
Raise and remove the maintenance cover.

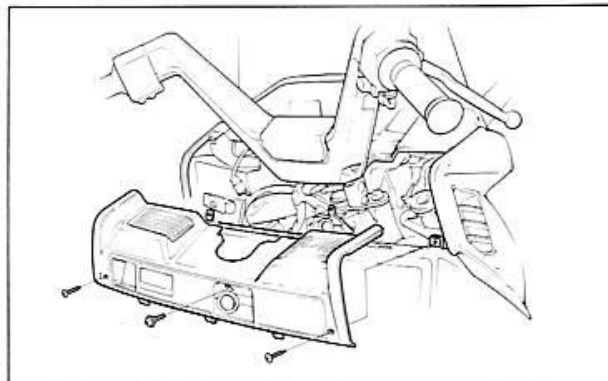
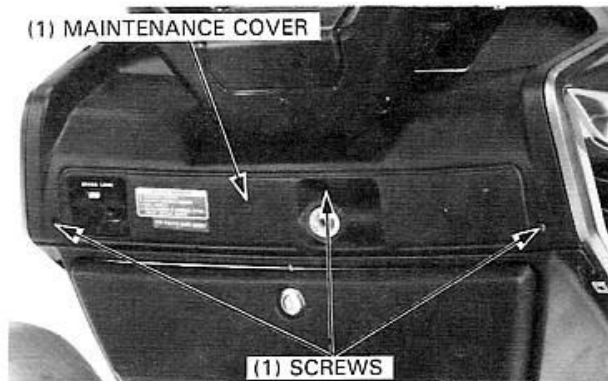

BODY CENTER COVER

Remove the seat (page 13-2).
Remove the four screws and maintenance lid by releasing the tabs from the slots.

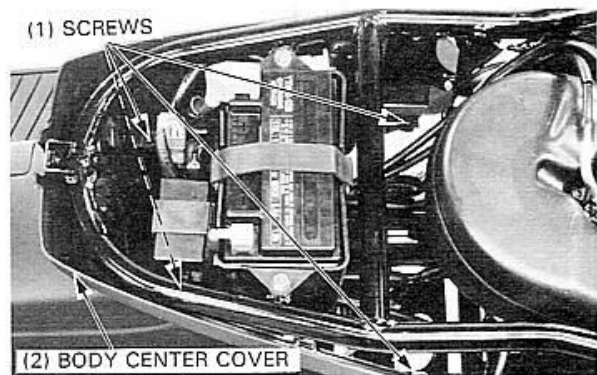

SIDE RAIL

REMOVAL

Remove the rear cover (page 13-2).
Remove the side rail attaching bolt.
Slide the side rail rearward, then pull up the side rail to release the tabs and remove the side rail.

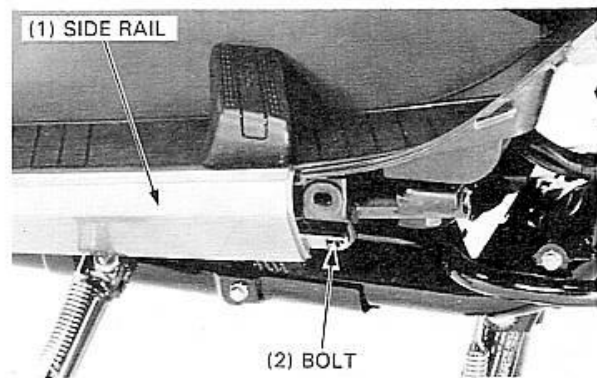

INSTALLATION

Align the tabs on the side rail with the slots in the floor panel.
Slide down the side rail, then to the forward aligning the tabs of the side rail with the slots in the front lower cover.
Install and tighten the side rail attaching bolt.

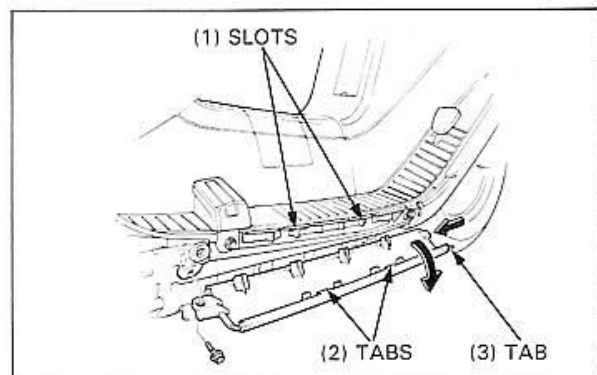

FLOOR MAT/FOOT PEG

Remove the rear cover (page 13-2) and side rail.
Remove the foot peg mounting bolt and foot peg.
Remove the floor mat.

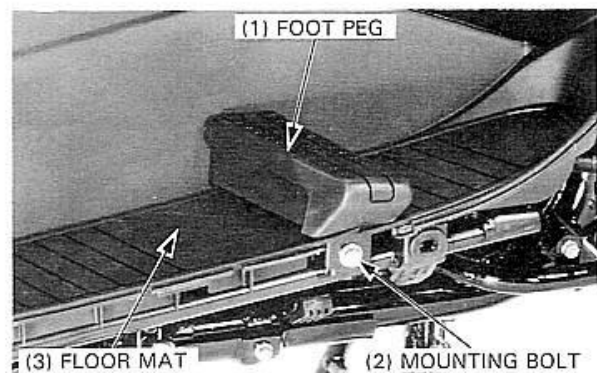

FRAME COVERS/REAR FRAME

SEAT

Remove the seat mounting bolt and remove the seat.

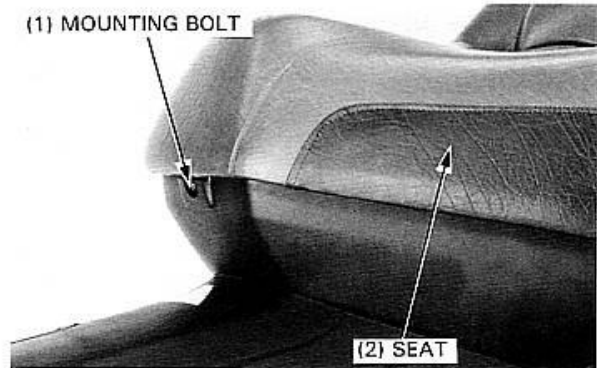

REAR COVER

Remove the four screws attaching the rear cover.
Open the rear trunk.
Take off the rear cover from the rear mud guard, then unhook the tab from the trunk cover.
Take off the rear cover tab from the floor plate by pushing down the floor plate.
Pull out the rear cover from the grommet in the floor panel.

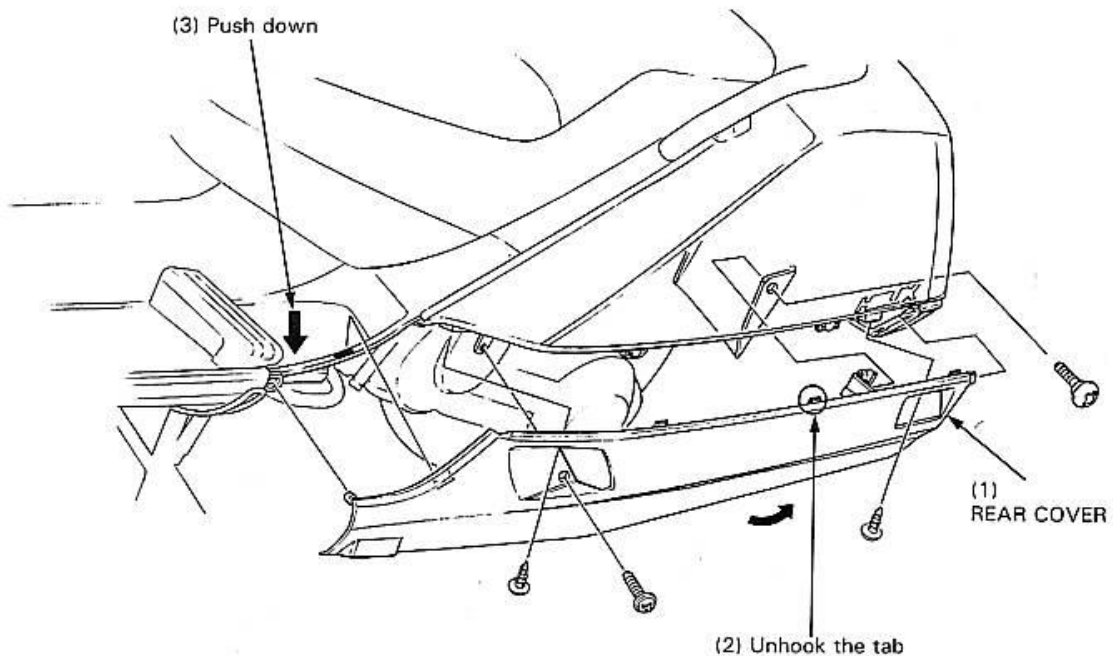
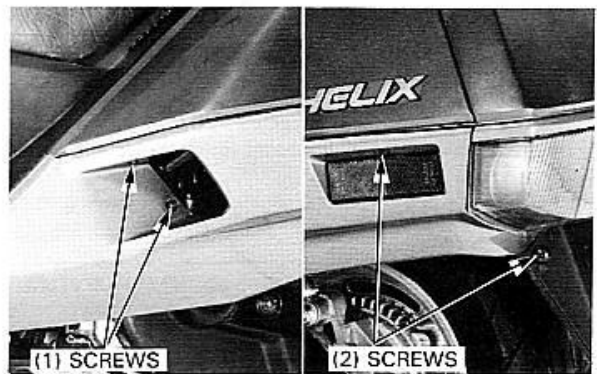

FRAME COVERS/REAR FRAME

FRONT LOWER COVER

Remove the following:

- rear covers (page 13-2)
- side rails (page 13-5)
- side visor by removing the five screws.

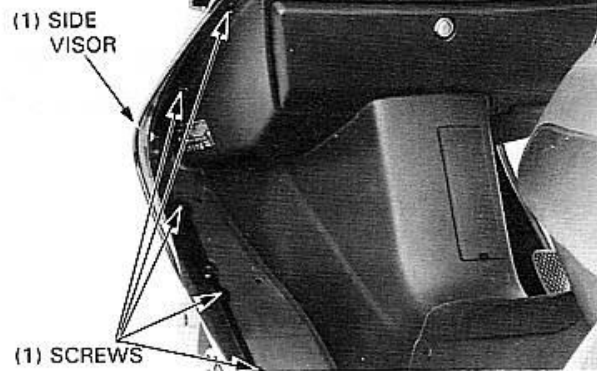

- front inner fender B by removing the four screws.

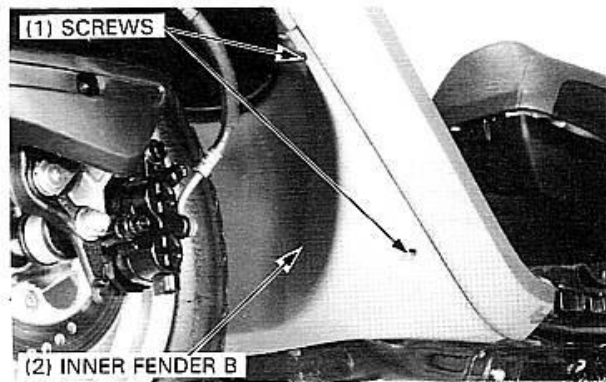

- front inner fender A by removing the six screws.

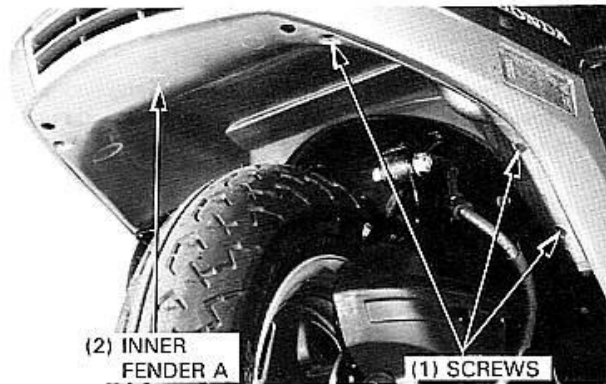

Remove the six screws and four bolts and remove the front lower cover.

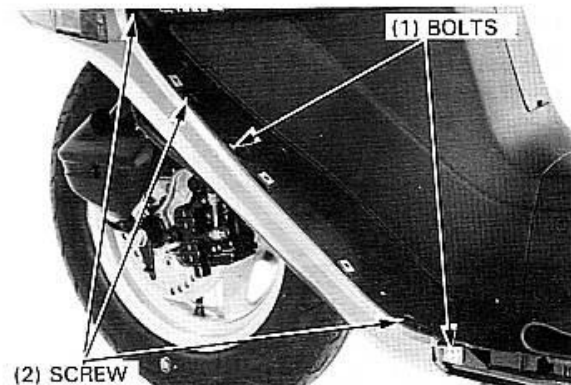

FRONT UPPER COVER

Remove the rear view mirror mounting bolts and rear view mirror.

Remove the front moulding.

Remove the maintenance cover (page 13-3).

NOTE: Use a hair-dryer to preheat the rear view mirror covers before rolling them up !

(1) REAR VIEW MIRROR

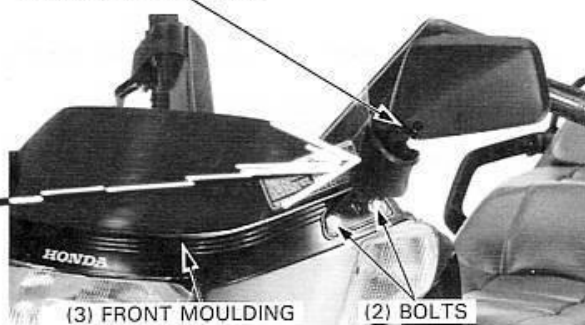

Remove the windscreen attaching screws and windscreen.

(1) WINDSCREEN



Remove the four instrument panel attaching screws and instrument panel.

(2) INSTRUMENT PANEL

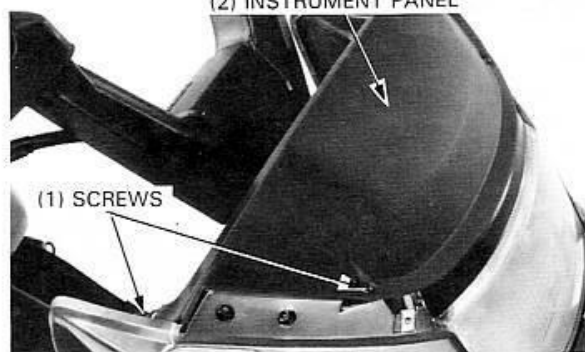

Remove the two lower screws attaching the front upper cover. Remove the side visors and remove the six screws attaching the front upper cover, and remove the front upper cover.

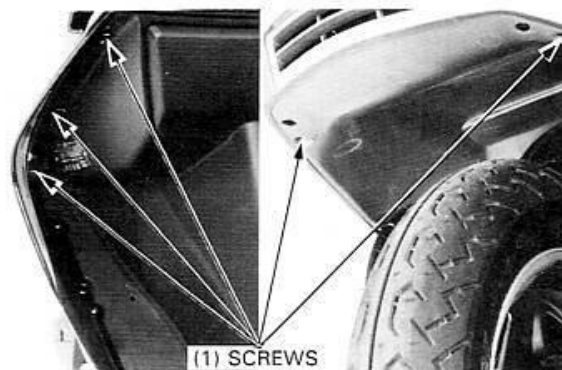

FRAME COVERS/REAR FRAME

FLOOR PANEL

Remove the following:

- right and left rear covers (page 13-2) and side rails (page 13-5).
- maintenance lid (page 13-5).
- foot pegs and floor mat (page 13-5).
- four bolts attaching the floor panel and floor panel.

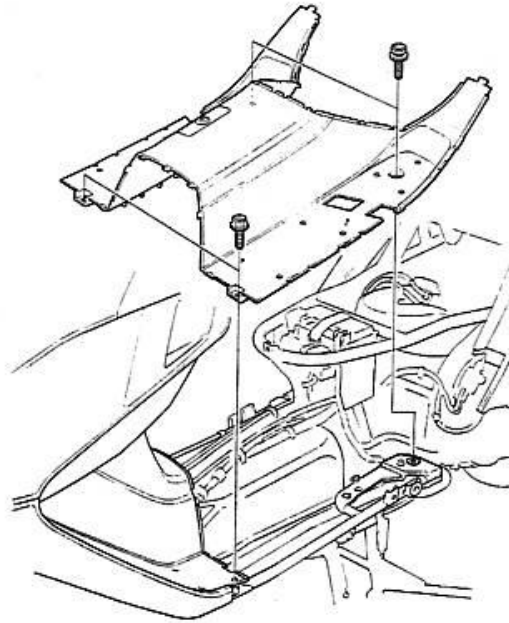

INNER BOX

Remove the following:

- front upper cover (page 13-7).
- floor panel.
- six screws, two bolts and inner box.

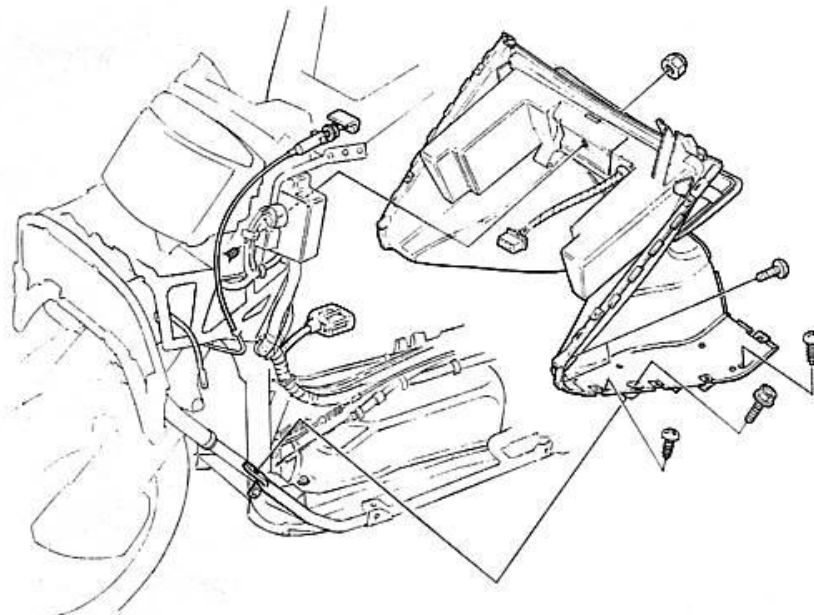

REAR FRAME

Remove the right and left rear covers (page 13-2).
Remove the two grab rail bolts and helmet holder.

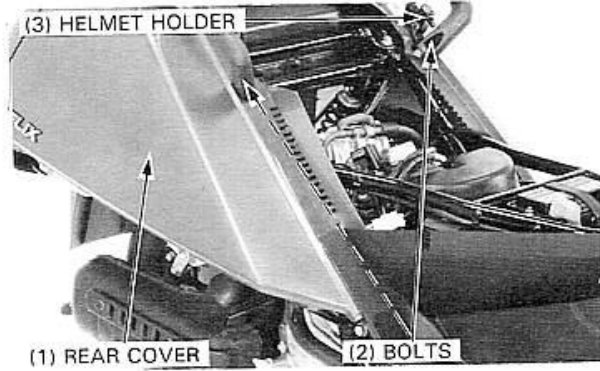

Raise the rear frame.
Disconnect the rear frame wire coupler and remove the clamps.
Remove the rear frame.

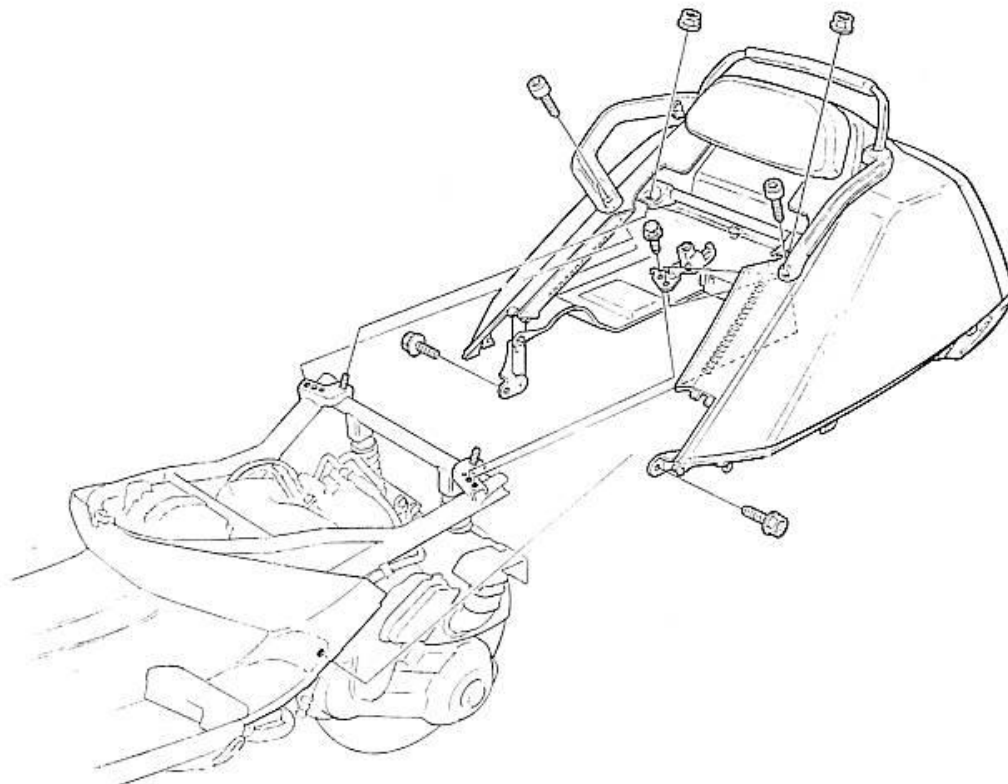
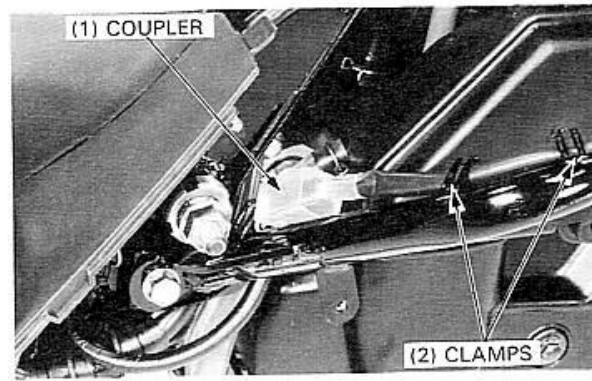

STEERING/FRONT WHEEL/SUSPENSION

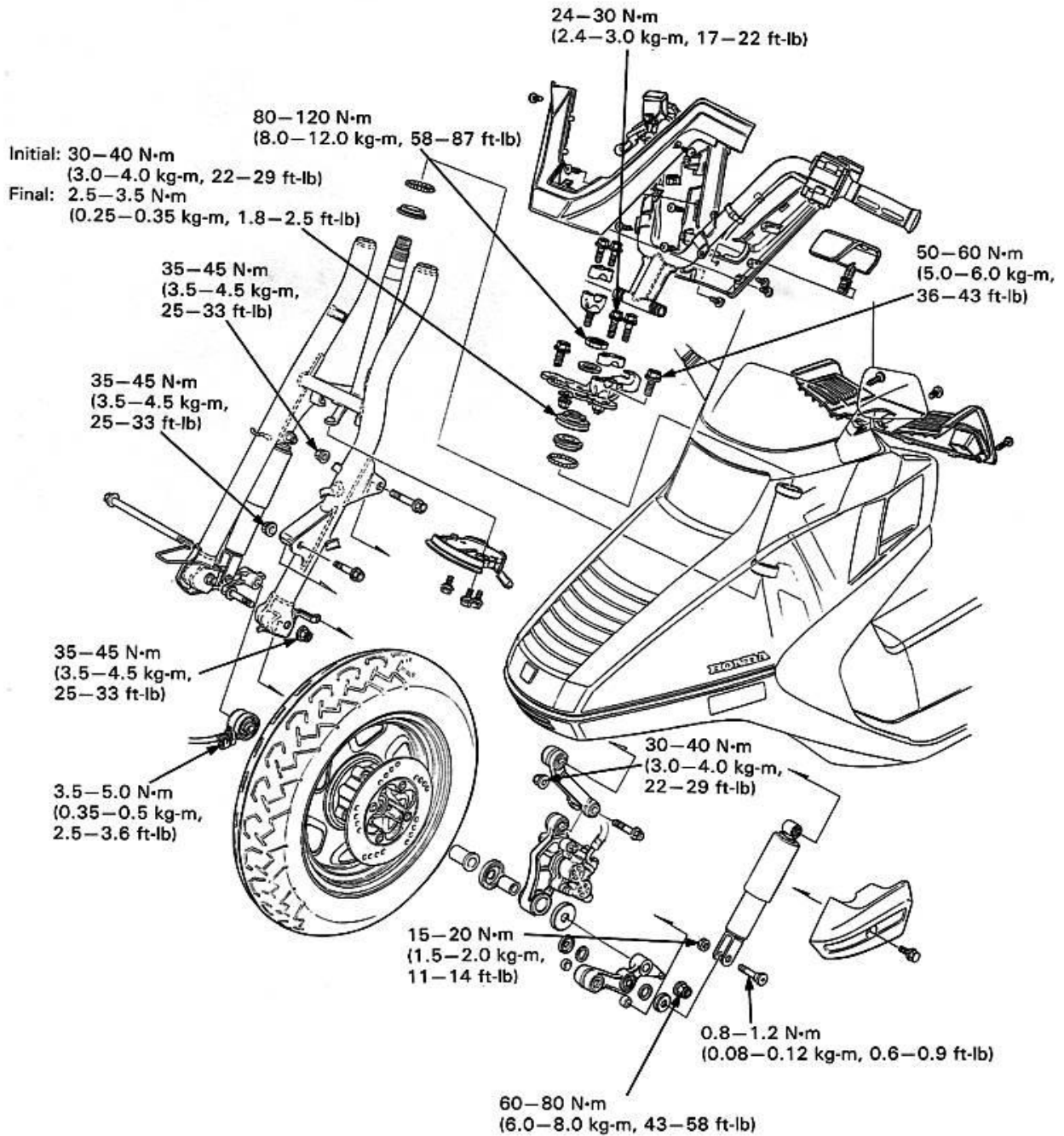

14. STEERING/FRONT WHEEL/SUSPENSION

SERVICE INFORMATION	14-1	FRONT WHEEL	14-5
TROUBLESHOOTING	14-2	SUSPENSION	14-10
HANDLEBAR	14-3	STEERING	14-14

SERVICE INFORMATION

GENERAL

Refer to the tubeless Tire Repair Manual for tire removal, repair and remounting procedures.

SPECIFICATIONS

ITEM		STANDARD mm (in)	SERVICE LIMIT mm (in)
Axle runout		—	0.2 (0.008)
Rim runout	Radial	—	2.0 (0.08)
	Axial	—	2.0 (0.08)
Shock absorber spring free length		220.4 (8.68)	216.0 (8.50)

TORQUE VALUES

Steering stem nut	80–120 N·m (8.0–12.0 kg-m, 58–87 ft-lb)	
Front wheel hub nut	28–32 N·m (2.8–3.2 kg-m, 20–23 ft-lb) Apply oil	
Front axle nut	60–80 N·m (6.0–8.0 kg-m, 43–58 ft-lb)	
Brake disc bolt	37–43 N·m (3.7–4.3 kg-m, 27–31 ft-lb) Apply a locking agent	
Shock absorber:		
Upper mounting nut	35–45 N·m (3.5–4.5 kg-m, 25–33 ft-lb)	
Lower mounting bolt	0.8–1.2 N·m (0.08–0.12 kg-m, 0.6–0.9 ft-lb)	
Lower lock nut	15–20 N·m (1.5–2.0 kg-m, 11–14 ft-lb)	
Damper lock nut	15–25 N·m (1.5–2.5 kg-m, 11–18 ft-lb) Apply a locking agent	
Torque link arm nut:		
Front fork side	35–45 N·m (3.5–4.5 kg-m, 25–33 ft-lb)	
Caliper bracket side	30–40 N·m (3.0–4.0 kg-m, 22–29 ft-lb)	
Pivot arm nut	35–45 N·m (3.5–4.5 kg-m, 25–33 ft-lb)	
Bearing adjustment nut	(Initial)	30–40 N·m (3.0–4.0 kg-m, 22–29 ft-lb)
	(Final)	2.5–3.5 N·m (0.25–0.35 kg-m, 1.8–2.5 ft-lb)
Speedometer cable set screw	3.5–5.0 N·m (0.35–0.50 kg-m, 2.5–3.6 ft-lb)	
Handlebar upper holder bolt	24–30 N·m (2.4–3.0 kg-m, 17–22 ft-lb)	
Front fork bolt	50–60 N·m (5.0–6.0 kg-m, 36–43 ft-lb)	

TOOLS

Special

Spring attachment	07967–KM10100 Not available in U.S.A.
Steering stem socket	07916–3710100
Ball race remover	07GMD–KS40100
Ball race remover attachment	07953–KM10100
Attachment	07945–3330300
Steering stem driver	07946–MB00000

Common

Bearing remover shaft	07746–0050100 equivalent commercially available in U.S.A.
Bearing remover head, 10 mm	07746–0050200 equivalent commercially available in U.S.A.
Bearing remover head, 12 mm	07746–0050300 equivalent commercially available in U.S.A.
Driver	07749–0010000
Attachment, 32 x 35 mm	07746–0010100
Attachment, 24 x 26 mm	07746–0010700
Pilot, 10 mm	07746–0040100
Pilot, 12 mm	07746–0040200
Shock absorber compressor	07959–3290001
Lock nut wrench 30 x 32 mm	07716–0020400 equivalent commercially available in U.S.A.
Extension	07716–0020500 equivalent commercially available in U.S.A.

STEERING/FRONT WHEEL/SUSPENSION

TROUBLESHOOTING

Hard steering

- Steering stem nut too tight
- Steering stem bearings damaged
- Steering ball and cone races damaged
- Insufficient tire pressure

Steers to one side or does not track straight

- Uneven front shocks
- Bent front fork
- Bent front axle

Front wheel wobbling

- Bent rim
- Axle nut tightened improperly
- Bent spoke plate
- Faulty or unevenly worn tire
- Excessive wheel bearing play

Soft suspension

- Weak fork springs
- Damper oil leaks

Front suspension noise

- Fork link binding
- Loose front fork fasteners

HANDLEBAR

REMOVER

Remove the screws, release the tabs and remove the handlebar center and upper covers.

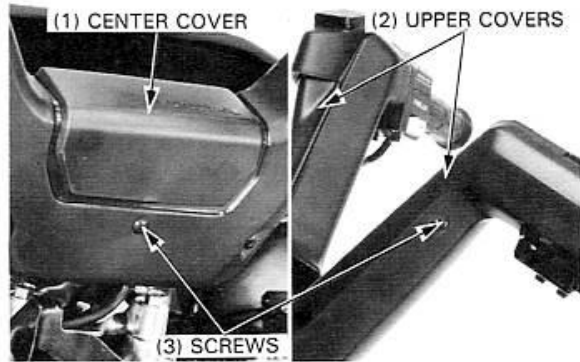

Remove the handlebar lower covers.

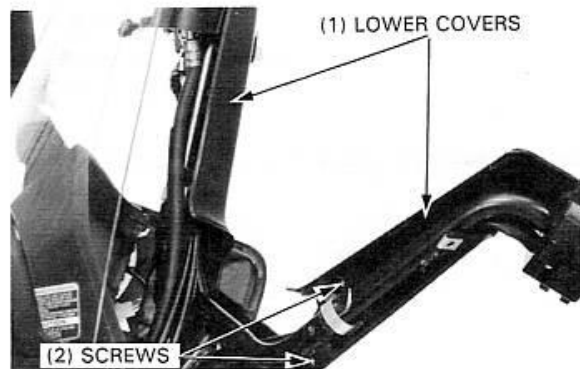

Remove the master cylinder cover.
Remove and loosen the wire clamps.
Remove the right and left handlebar switch housings and disconnect the throttle cables from the throttle grip.
Remove the master cylinder holder bolts and master cylinder from the handlebar.

NOTE

- Do not remove the brake hose bolt from the brake master cylinder.

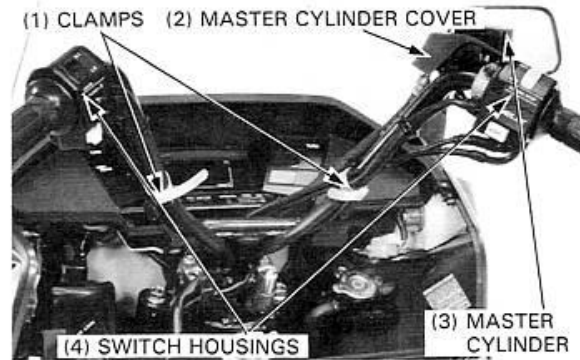

Remove the wire clamp from the handlebar.
Remove the handlebar upper holder bolts, upper holders and handlebar.

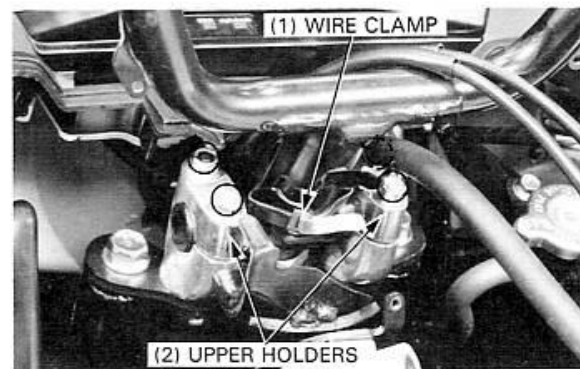

STEERING/FRONT WHEEL/SUSPENSION

INSTALLATION

Install the handlebar onto the lower holders aligning the punch mark on the handlebar with the upper surfaces of the lower holders.

Apply Honda Bond A or Honda Hand Grip Cement (U.S.A. only) to the inside surface of the grips and to the clean surface of the left handlebar and throttle pipe. Wait 3–5 minutes and install the grips.

Rotate the grips for even application of the adhesive.

NOTE

- Allow the adhesive to dry for an hour before using.

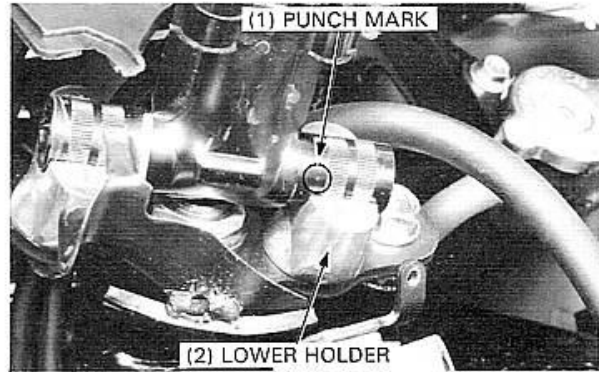

Install the handlebar upper holders with the punch marks facing forward and tighten the forward bolts first, then tighten the rear bolts.

TORQUE: 24–30 N·m (2.4–3.0 kg·m, 17–22 ft·lb)

NOTE

- Make sure that the punch mark on the handlebar aligns with the upper surface of the lower holder.

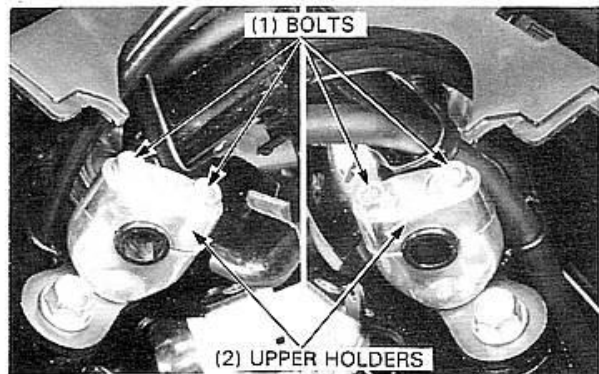

Install the master cylinder and master cylinder holder with the UP mark facing up and aligning the end of the holder with the punch mark on the handlebar. Tighten the upper bolt first, then tighten the lower bolt.

TORQUE: 24–30 N·m (2.4–3.0 kg·m, 17–22 ft·lb)

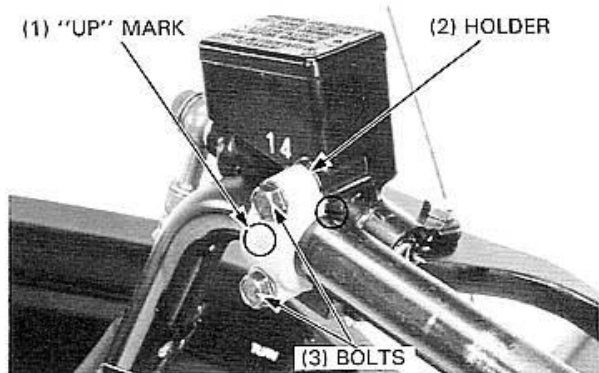

Insert the throttle grip onto the handlebar and connect the throttle cables to the throttle grip.

Install the right handlebar switch housing aligning the locating pin on the housing with the hole in the handlebar.

Apply grease to the throttle cable ends.

Loosely install the two housing attaching screws.

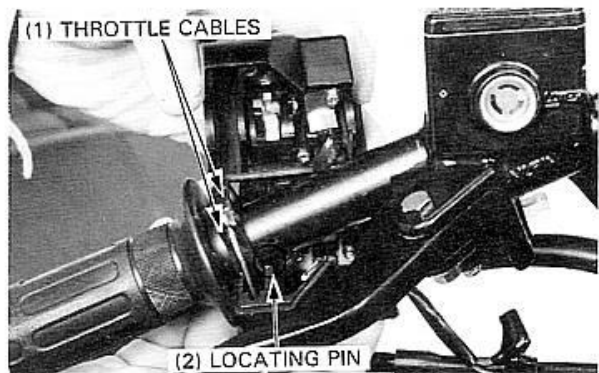

Install the left handlebar switch housing onto the handlebar and loosely tighten the screws.

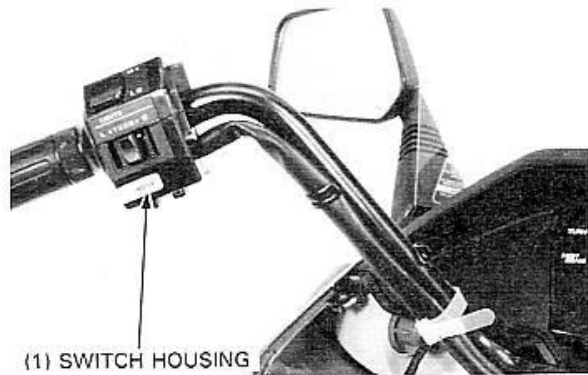

Route and clamp the wires and cables properly (page 1-9).

Install the handlebar covers in the reverse order of removal. Tighten the right and left handlebar switch housing forward screws first, then the rear screws.

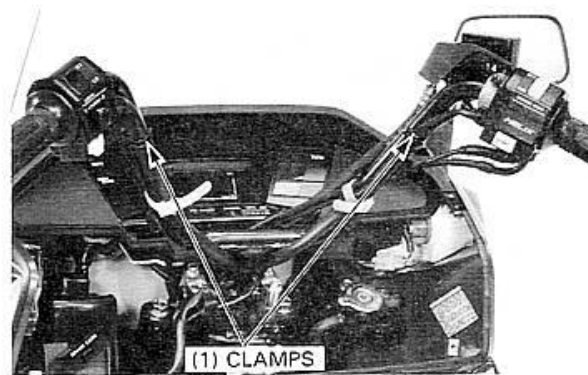

FRONT WHEEL

REMOVAL

Remove the speedometer cable set screw and disconnect the cable.

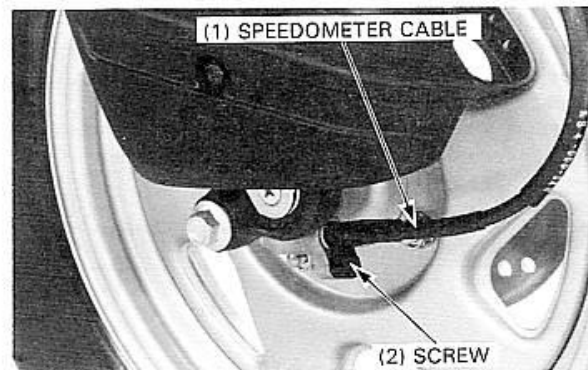

Raise the front wheel off the ground by placing a floor jack or other adjustable support under the frame.

Remove the axle nut, axle and front wheel.
Remove the side collar.

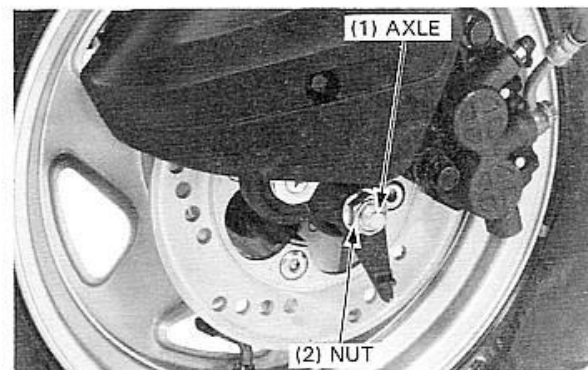

STEERING/FRONT WHEEL/SUSPENSION

INSPECTION

AXLE SHAFT

Set the axle shaft in V blocks and measure the runout using a dial indicator.

SERVICE LIMIT: 0.2 mm (0.01 in)

Replace if the reading exceeds the service limit.

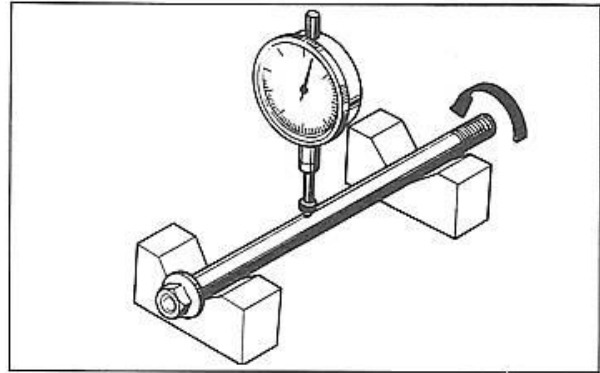

WHEEL RIM

Place the wheel in a truing stand.

Spin the wheel by hand and measure the rim runout using a dial gauge.

SERVICER LIMITS:

RADIAL: 2.0 mm (0.08 in)

AXIAL: 2.0 mm (0.08 in)

Replace if the reading exceeds the service limit.

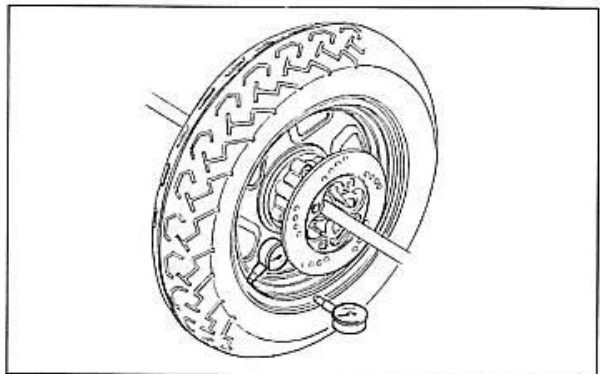

WHEEL BEARING

Turn the inner race of each bearing with your finger.

The bearings should turn smoothly and quietly. Also check that the bearing outer race fits tightly in the hub.

Remove and discard the bearings if the races do not turn smoothly, quietly, or if they fit loosely in the hub.

NOTE

- Replace the hub bearings in pairs.

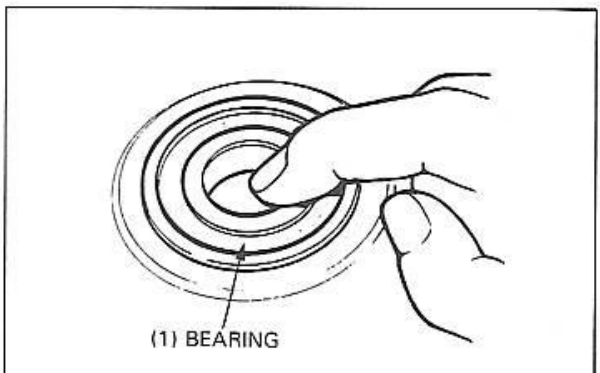

BEARING REPLACEMENT

Remove the dust seal from the wheel hub.

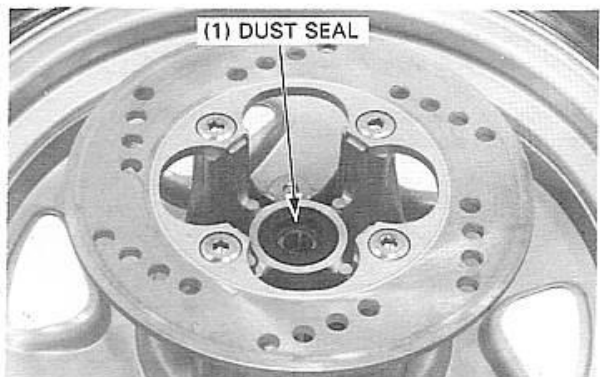

STEERING/FRONT WHEEL/SUSPENSION

Install the bearing remover head into the bearing.
From the opposite side install the bearing remover shaft and drive the bearing out of the hub.

Remove the spacer and drive out the other bearing.

NOTE

- If the bearings are removed, they must be replaced with new ones as a set.
- Drive out the speedometer gear retainer on the right side of the wheel hub with the bearing.

TOOLS:

Bearing remover head, 12 mm	07746-0050300 or equivalent commercially available in U.S.A.
Bearing remover shaft	07746-0050100 or equivalent commercially available in U.S.A.

Drive the left bearing in securely, until it's seated.
Install the spacer and drive the right bearing in securely, until it's seated.

NOTE

- Do not allow the bearings to tilt while driving them in.
- Never reinstall an old bearing, once a bearing is removed, it must be replaced with a new one.

TOOLS:

Driver	07749-0010000
Attachment, 32 x 35 mm	07746-0010100
Pilot, 12 mm	07746-0040200

Drive the speedometer gear retainer over the right bearing.

TOOLS:

Driver	07749-0010000
Attachment, 32 x 35 mm	07746-0010100

Install the dust seal over the left bearing.

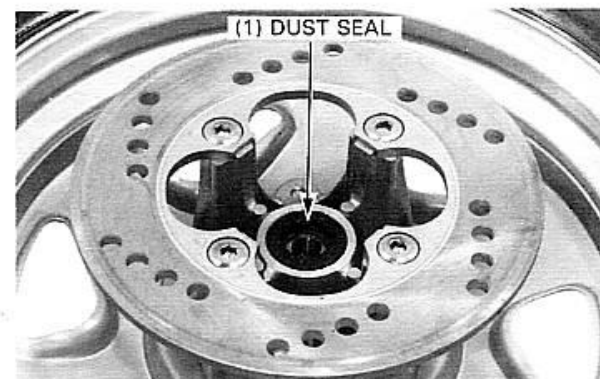
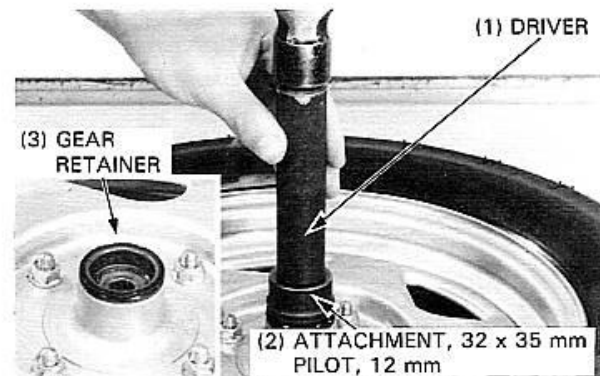
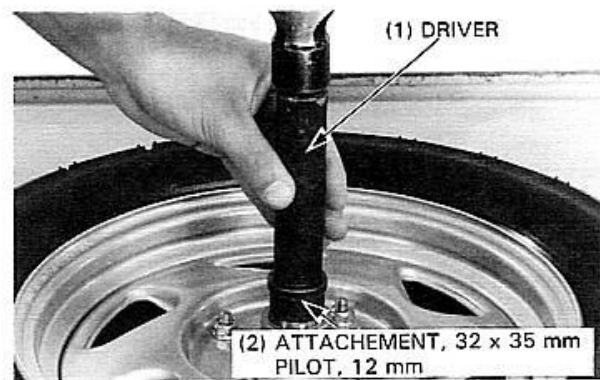
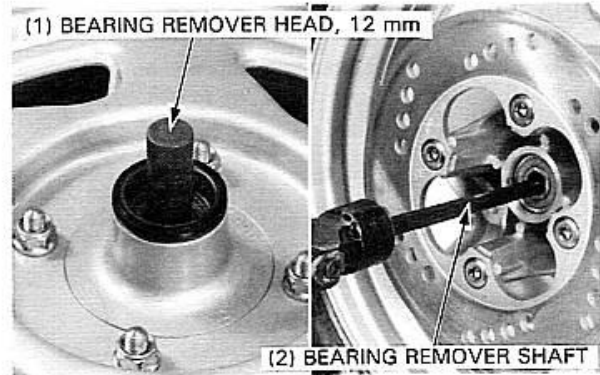

STEERING/FRONT WHEEL/SUSPENSION

DISASSEMBLY

Remove the brake disc mounting bolts and brake disc.

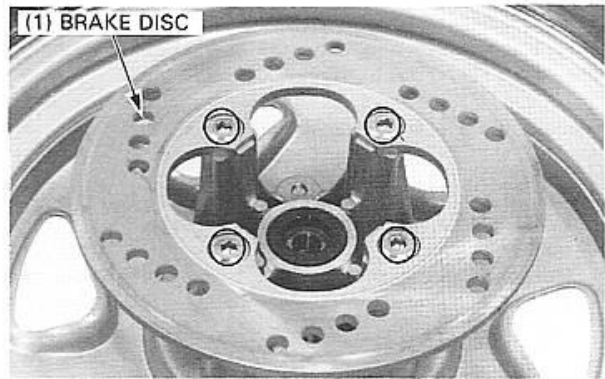

Remove the wheel hub mounting bolts and the wheel hub.



ASSEMBLY

Assemble the front wheel in the reverse order of disassembly.

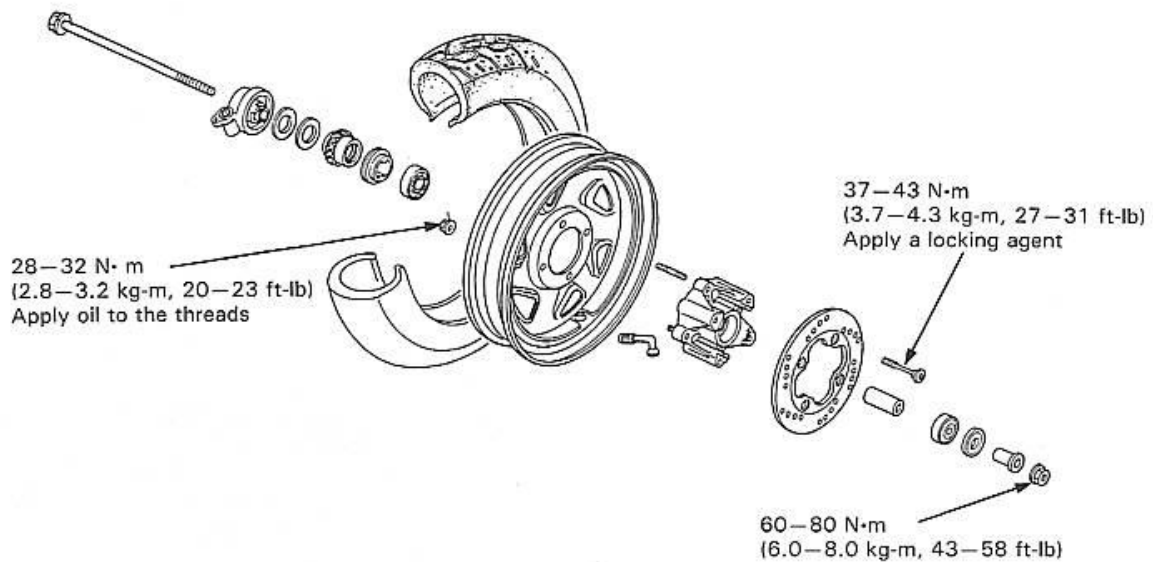

Install the side collar into the left side of the wheel hub.

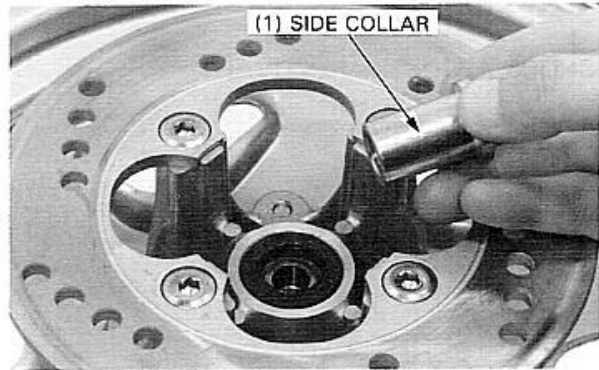

Apply grease to the lip of the speedometer gear retainer and the speedometer gear, and install the gear case aligning the tabs on the retainer with the groove in the gear.

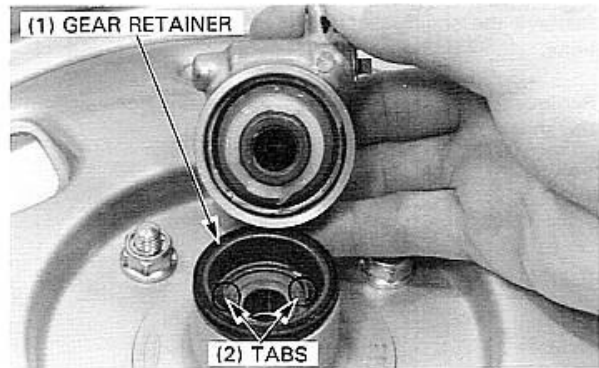

INSTALLATION

Install the front wheel aligning the brake disc between the brake pads.

NOTE

- Make sure that the stoppers on the speedometer gear case and pivot arm are aligned.

Insert the axle from the right side and tighten the axle nut.

TORQUE: 60–80 N·m (6.0–8.0 kg-m, 43–58 ft-lb)

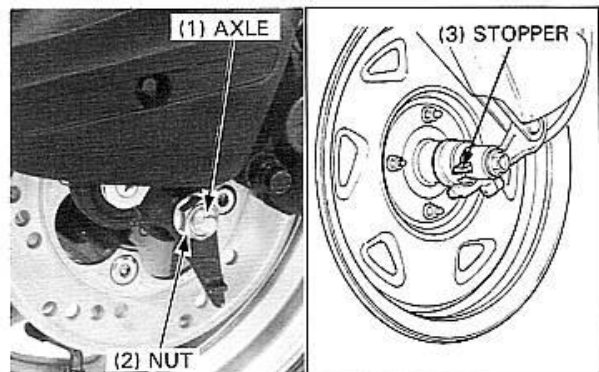

Install the speedometer cable and tighten the set screw.

TORQUE: 3.5–5.0 N·m (0.35–0.50 kg-m, 2.5–3.6 ft-lb)

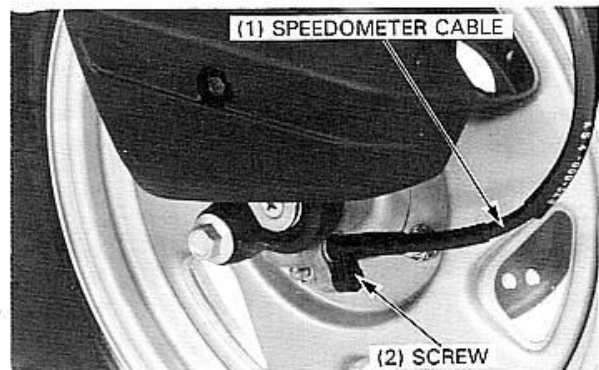

SUSPENSION

SHOCK ABSORBER REMOVAL

Remove the pivot arm covers.

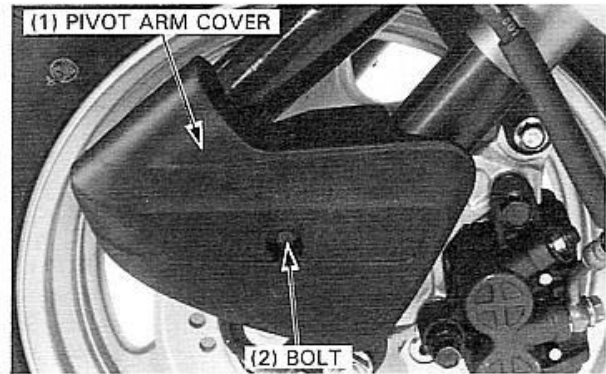

Remove the shock absorber lower mounting lock nuts and bolts.

Remove the shock absorber upper mounting bolts and remove the shock absorber.

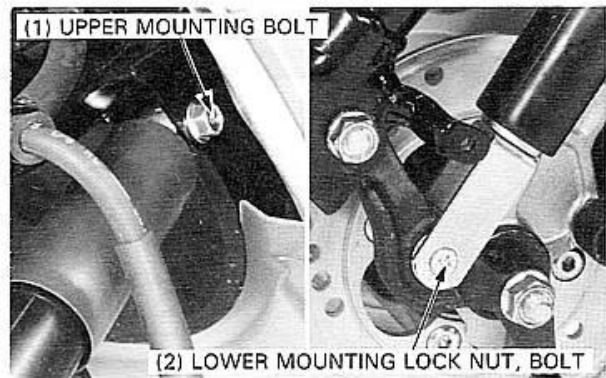

SHOCK ABSORBER DISASSEMBLY

Set the shock absorber in the shock absorber compressor as shown and compress the spring 30 mm by turning the compressor handle.

TOOLS:

Shock absorber compressor
Spring attachment

07959-3290001
07967-KM10100
Not available in U.S.A.

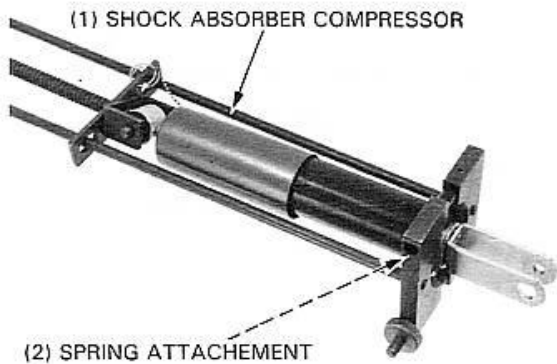

Pull the damper rod.

Loosen the lock nut and remove the lower clevis.

Remove the shock absorber spring.

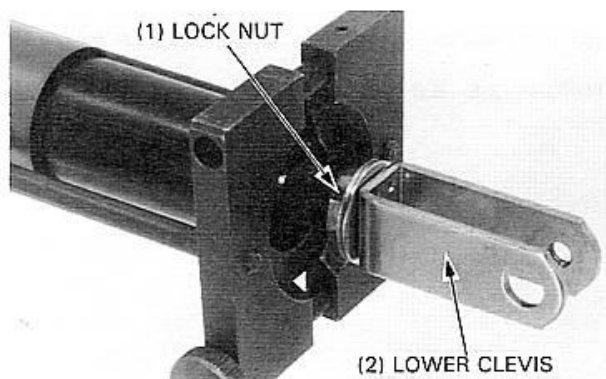

INSPECTION

Check the shock absorber spring for damage and loss of tension.

Measure the shock absorber spring free length.

SERVICE LIMIT: 216.0 mm (8.50 in)

Check the damper unit for damage or bending and replace if necessary.

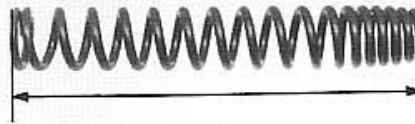

ASSEMBLY

Install the shock absorber spring with the closely wound coils toward the bottom.

Compress the shock absorber spring with the shock absorber compressor and attachment.

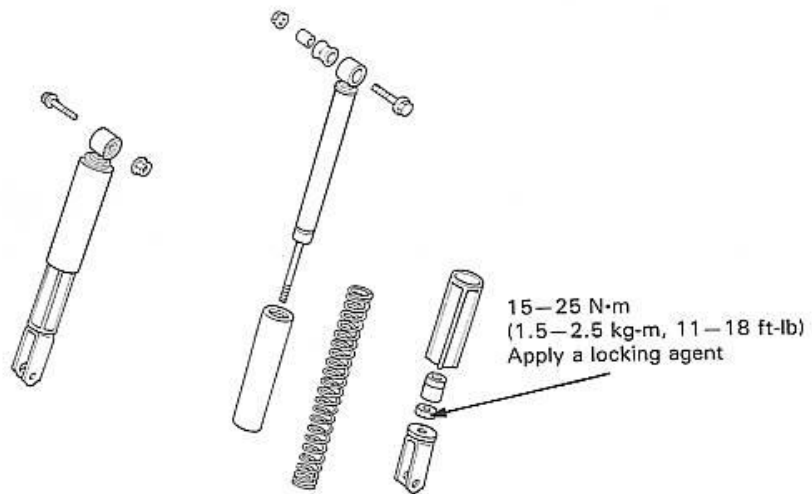

Expand the damper rod fully and apply locking agent to the threaded portion of the damper rod and lock nut. Install the lower clevis and tighten the lock nut.

TORQUE: 15–25 N·m (1.5–2.5 kg·m, 11–18 ft·lb)

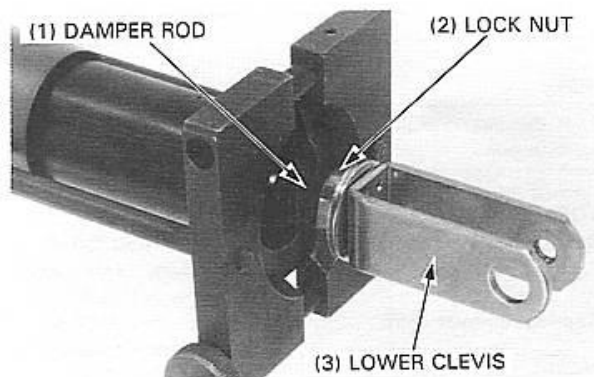

STEERING/FRONT WHEEL/SUSPENSION

PIVOT ARM/CALIPER BRACKET/TORQUE LINK REMOVAL

Remove the front wheel (page 14-5).
Remove the shock absorber (page 14-10).
Remove the bolts and nuts and remove the torque link, caliper bracket and pivot arm.

PIVOT ARM DISASSEMBLY

Remove the dust caps, seals and collar from the pivot arm.
Inspect the collar and bushing for wear or damage.
Remove the pivot arm collars and dust seals.

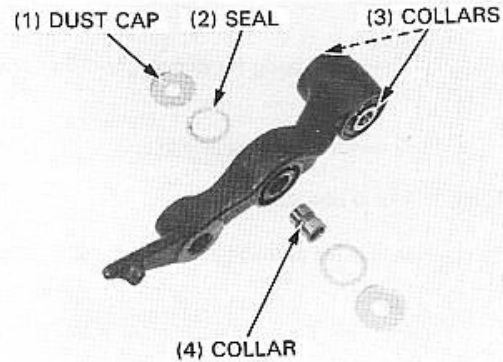

BEARING INSPECTION

Turn the pivot arm bearing inner races with your finger.
The bearing should turn smoothly and quietly.
Also check that the bearing outer races fit tightly in the pivot arm.

Remove and discard the bearings if the races do not turn smoothly, quietly or if they fit loosely in the pivot arm.

NOTE

- Replace the pivot arm bearings in pairs.

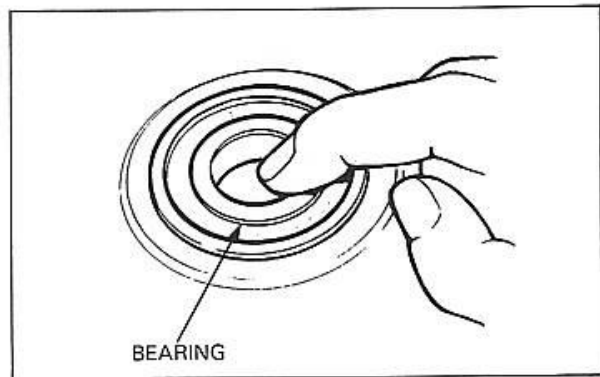

PIVOT ARM BEARING REPLACEMENT

Remove the snap ring from the pivot arm.

Install the bearing remover head into the pivot arm bearing.
From opposite side, install the bearing remover shaft and drive the bearing out of the pivot arm. Remove the spacer and other bearing.

NOTE

- If the bearings are removed, they must be replaced with new ones.

TOOLS:

Bearing remover head, 10 mm	07746-0050200 or equivalent commercially available in U.S.A.
Bearing remover shaft	07746-0050100 or equivalent commercially available in U.S.A.

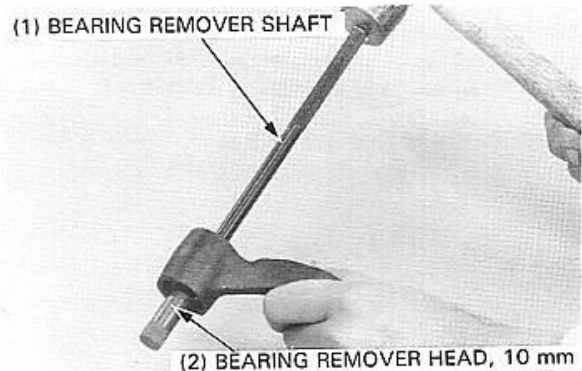
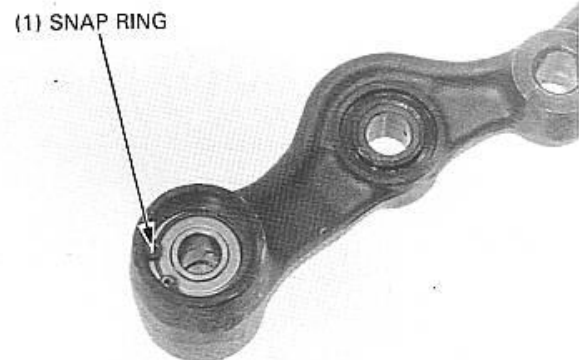

STEERING/FRONT WHEEL/SUSPENSION

Drive the right pivot arm bearing in securely until it's seated. Install the spacer and drive the left bearing in securely until it's seated.

NOTE

- Do not allow the bearings to tilt while driving them in.
- Never reinstall an old bearing once a bearing is removed, it must be replaced with a new one.

TOOLS:

Driver	07749-0010000
Attachment, 24 x 26 mm	07746-0010700
Pilot, 10 mm	07746-0040100

Install the snap ring into the pivot arm groove.

Apply grease to the lip of the dust seals and install the dust seals over the pivot arm bearings.

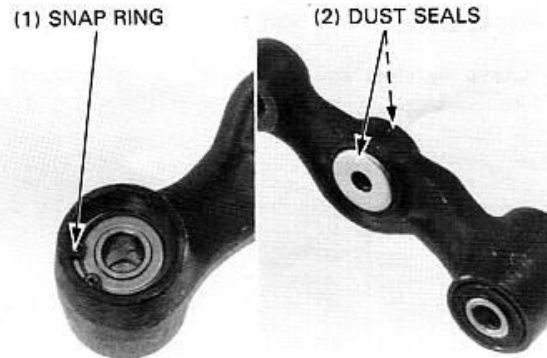
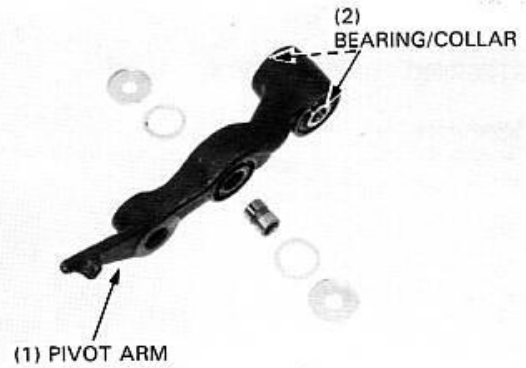

INSTALLATION

Install the pivot arm, caliper bracket, torque link, shock absorber and front wheel in the reverse order of removal.

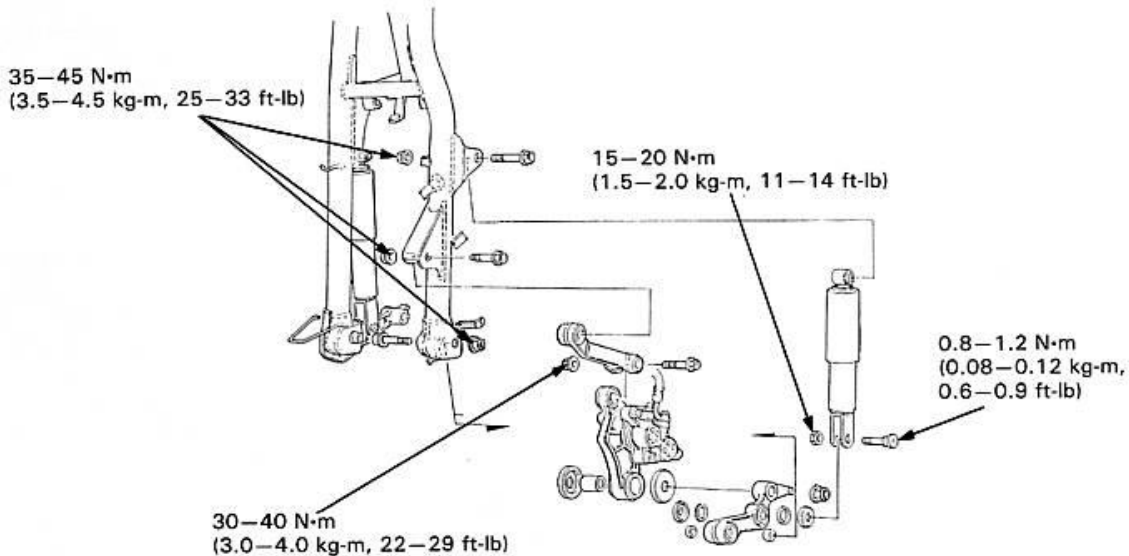

STEERING/FRONT WHEEL/SUSPENSION

STEERING

STEERING FORK REMOVAL

Remove the front wheel (page 14-5).
Remove the front fork fender by removing the three bolts.

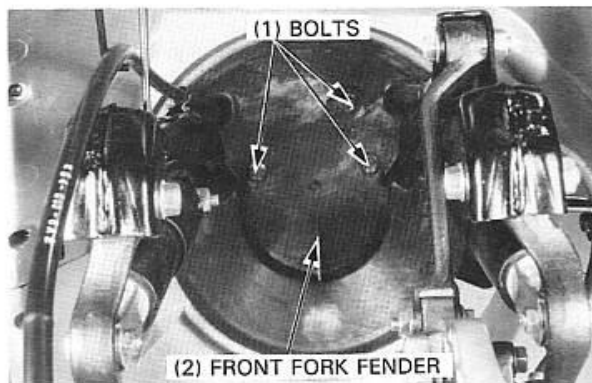

Remove the front suspension (page 14-10).

Unclamp the brake hose and speedometer cable from the front fork.

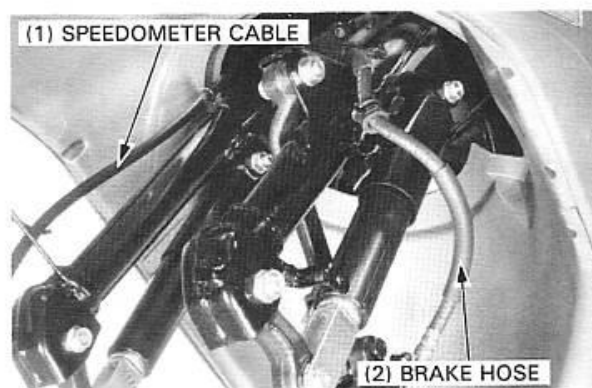

Remove the handlebar (page 14-3).
Remove the steering stem nut and washer.

TOOLS:

Lock nut wrench, 30 x 32 mm 07716-0020400
equivalent commercially
available in U.S.A.
Extension 07716-0020500
equivalent commercially
available in U.S.A.

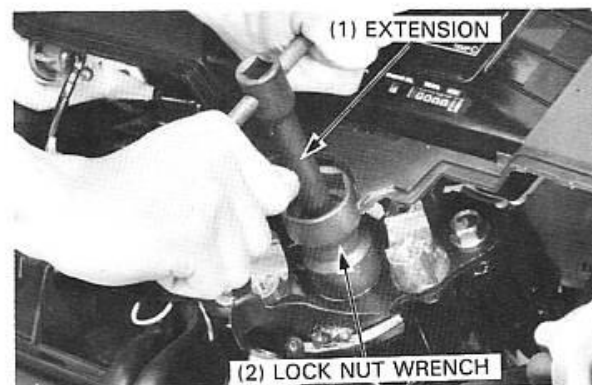

Remove the front fork bolts and fork bridge.

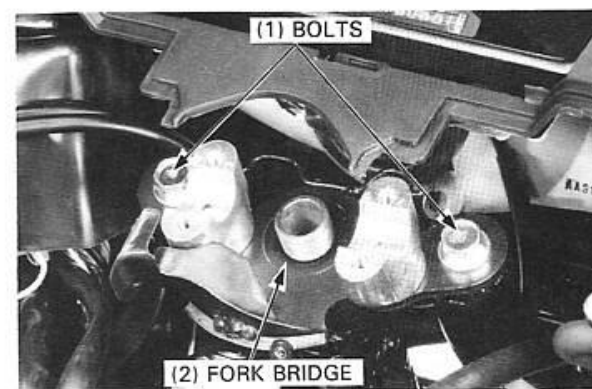

Remove the bearing adjustment nut.

TOOLS:

Steering stem socket
Extension

07916-3710100
07716-0020500
equivalent commercially
available in U.S.A.

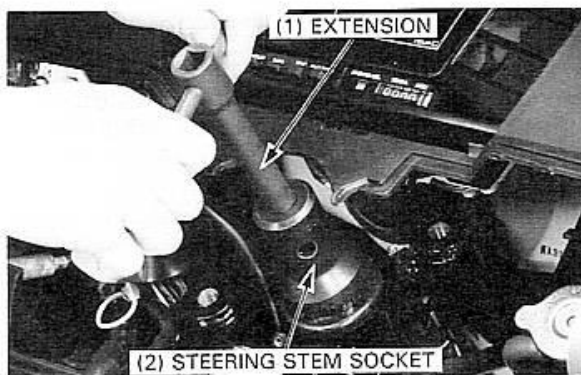

Place a shop towel over the frame cover opening and remove the top cone race and front fork.

NOTE

- Place the steel balls in a parts tray so they are not lost.

Remove the 18 steel balls from the top race and 19 balls from the bottom.



BALL RACE INSPECTION

Inspect the top and bottom ball races for wear or damage and replace if necessary.

NOTE

- Replace the steel balls and races as a set.
- If the scooter has been involved in an accident, examine the area around the steering head for cracks.

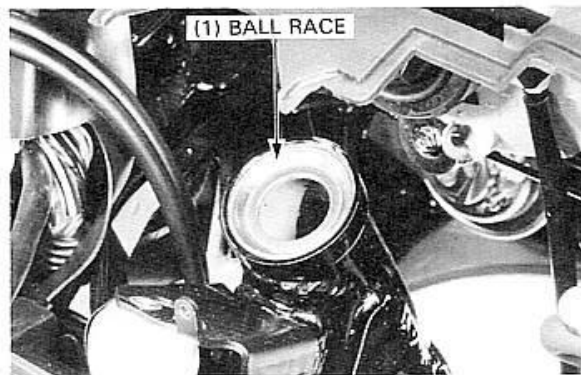

BALL RACE REPLACEMENT

Drive the top ball race out of the steering head.

TOOLS:

Ball race remover

07GMD-KS40100

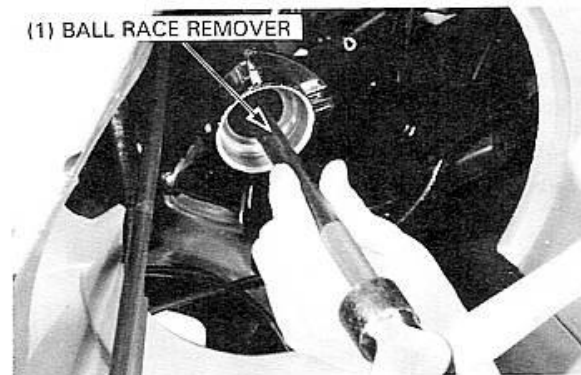

STEERING/FRONT WHEEL/SUSPENSION

Drive the bottom ball race out of the steering head.

TOOLS:

Ball race remover 07GMD-KS40100
Ball race remover attachment 07953-KM10100

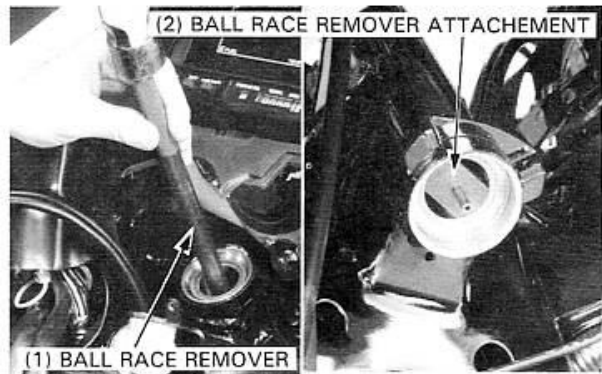

Drive new ball races into the steering head.

TOOLS:

Driver 07749-0010000
Attachment 07945-3330300

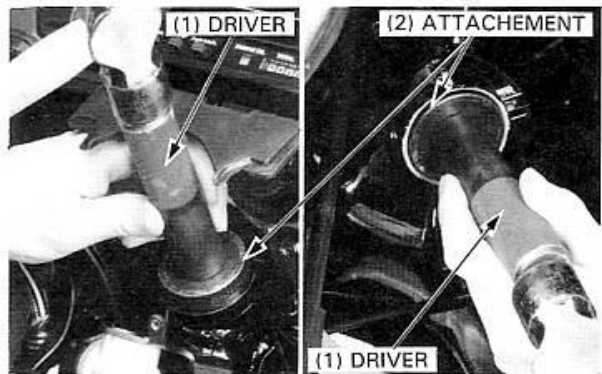

BOTTOM CONE RACE INSPECTION

Inspect the bottom cone race for wear or damage and replace if necessary.

BOTTOM CONE RACE REPLACEMENT

Remove the bottom cone race, dust seal and washer using a punch and discard them.

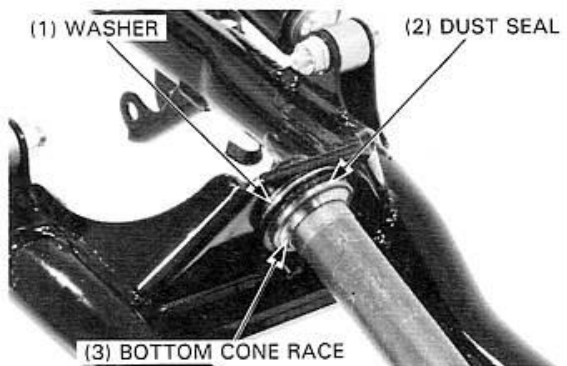

Place new washer, dust seal and bottom cone race onto the steering stem.

Use the old cone race inverted on top of the new race, to drive it into place.

TOOL:

Steering stem driver 07946-MB00000

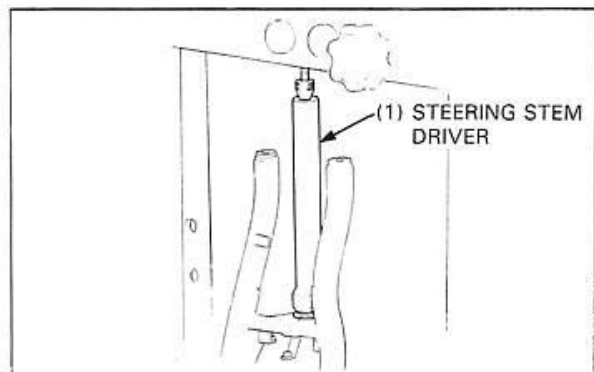

INSTALLATION

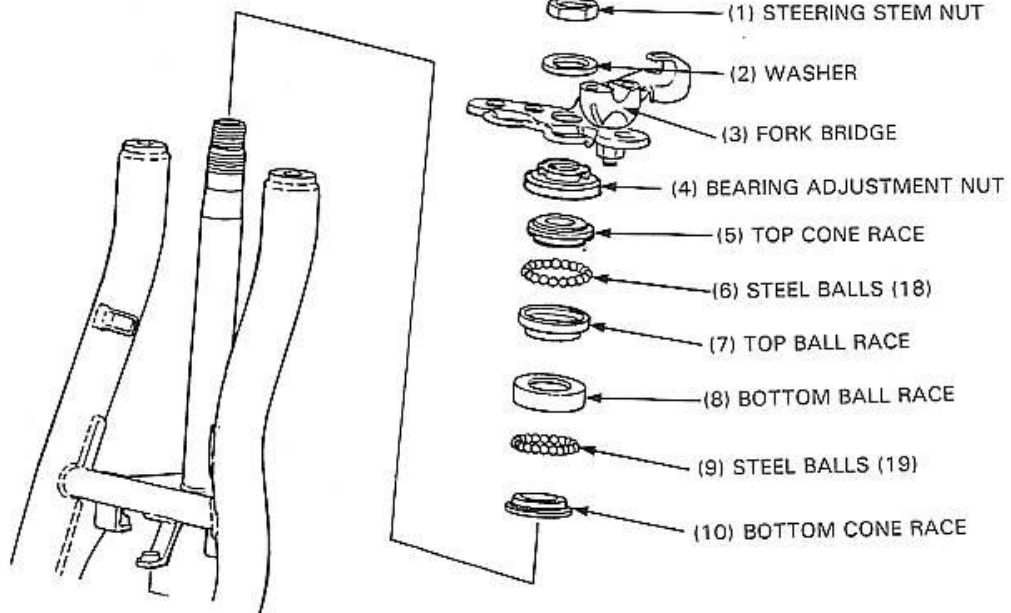

Apply grease to the top and bottom ball races and install the 18 steel balls onto the top ball race and 19 steel balls into the bottom ball race.

Insert the front fork into the steering head being careful not to drop the steel balls.

Remove the shop towel.

Apply grease to the top cone race and tighten the bearing adjustment nut to initial torque.

TORQUE: 30–40 N·m (3.0–4.0 kg-m, 22–29 ft-lb)

TOOLS:

Steering stem socket
Extension

07916–3710100
07716–0020500
equivalent commercially
available in U.S.A.

Loosen the bearing adjustment nut, then turn the front fork lock-to-lock five times to seat the steel balls.
Tighten the bearing adjustment nut to final torque.

TORQUE: 2.5–3.5 N·m (0.25–0.35 kg-m, 1.8–2.5 ft-lb)

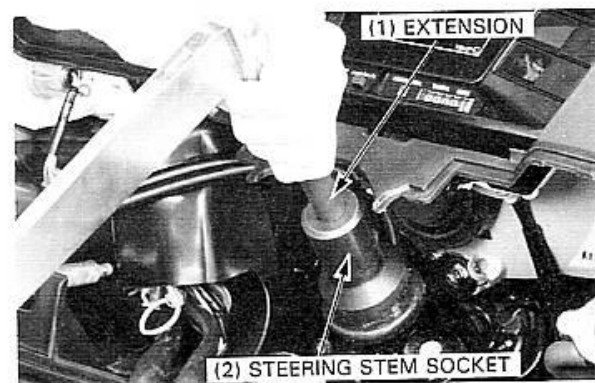

STEERING/FRONT WHEEL/SUSPENSION

Install the fork bridge and tighten the fork bolts.

TORQUE: 50–60 N·m (5.0–6.0 kg·m, 36–43 ft·lb)

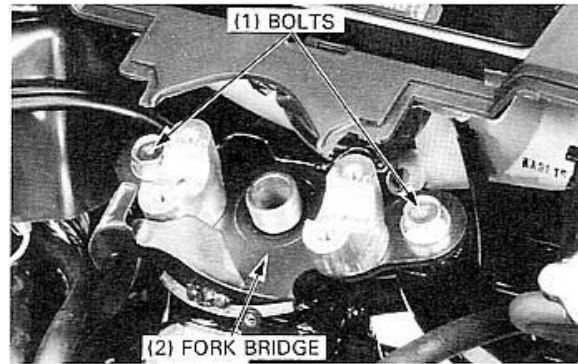

Install and tighten the steering stem nut.

TORQUE: 80–120 N·m (8.0–12.0 kg·m, 58–87 ft·lb)

TOOLS:

Lock nut wrench, 30 x 32 mm 07716–0020400
equivalent commercially
available in U.S.A.

Extension 07716–0020500
equivalent commercially
available in U.S.A.

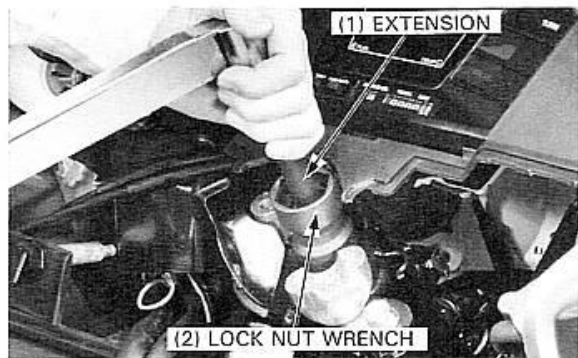

Install the followings:

- front suspension (page 14-13)
- front wheel (page 14-9)
- handlebar (page 14-4)

14-18

REAR WHEEL/BRAKE/SUSPENSION

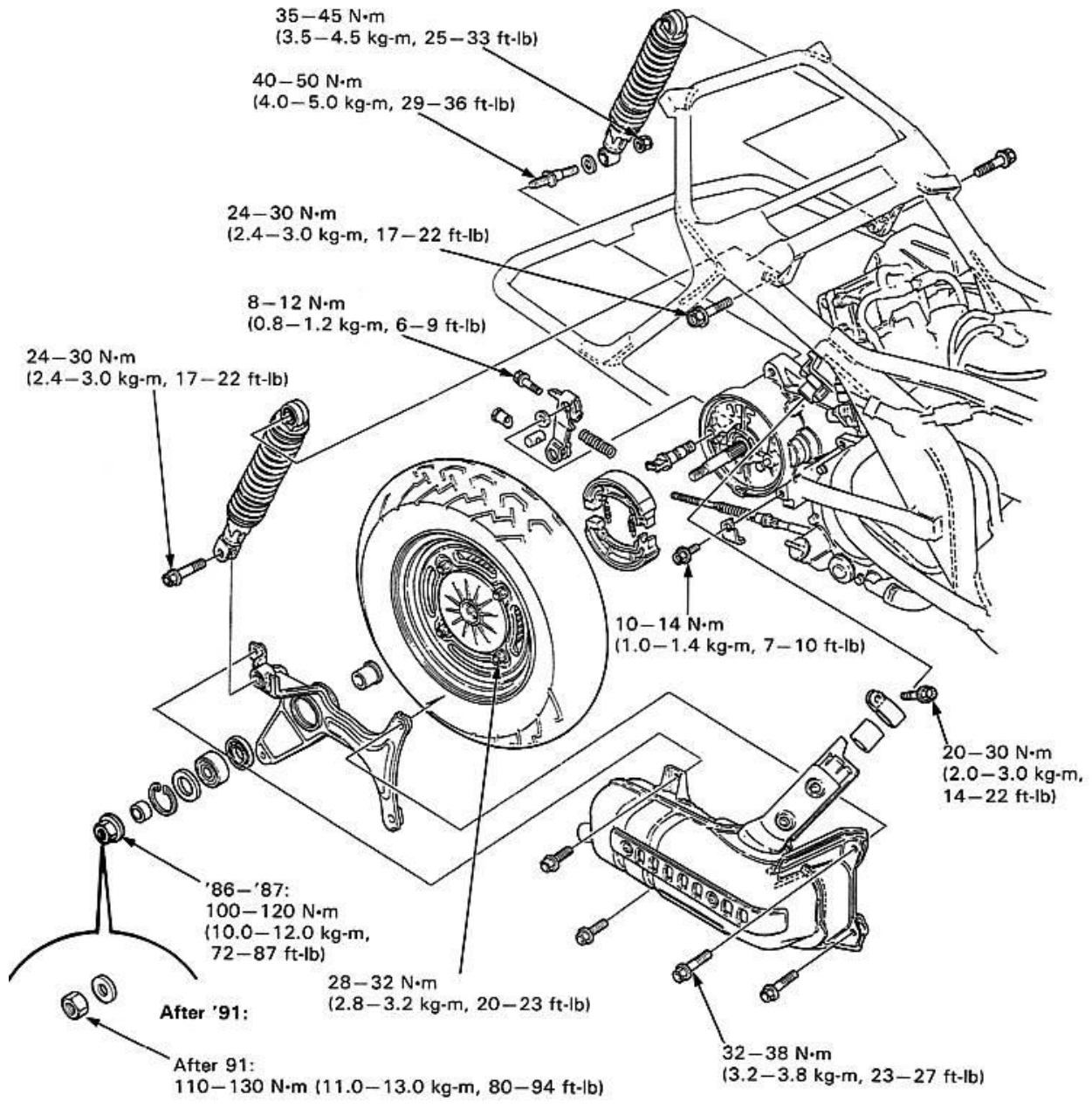

15. REAR WHEEL/BRAKE/SUSPENSION

SERVICE INFORMATION	15-1	REAR BRAKE	15-6
TROUBLESHOOTING	15-2	REAR BRAKE PEDAL/BRAKE LOCK SYSTEM	15-7
EXHAUST MUFFLER	15-3		
REAR WHEEL	15-3	REAR SHOCK ABSORBER	15-9

SERVICE INFORMATION

GENERAL

Refer to the Tubeless Tire Repair Manual for tire removal, repair, and remounting procedures.

WARNING

- Brake dust may contain asbestos which can be harmful to your health. Do not use compressed air to clean brake drums or brake panels. Use a vacuum with a sealed dust collector. Wear a protective face mask and thoroughly wash your hands when finished.

SPECIFICATIONS

ITEM	STANDARD mm (in)	SERVICE LIMIT mm (in)
Rear wheel rim runout		2.0 (0.08)
Rear brake drum I.D.	130.0 (5.12)	131.0 (5.16)
Rear brake lining thickness	4.0 (0.16)	2.0 (0.08)
Rear shock absorber spring free length '86:		
UPPER	191.7 (7.55)	187.9 (7.40)
LOWER	42.5 (1.67)	41.7 (1.64)
After '86:	236.8 (9.32)	232.1 (9.14)

TORQUE VALUES

Rear axle nut ('86-'87)	100–120 N·m (10.0–12.0 kg-m, 72–87 ft-lb)
(After '91)	110–130 N·m (11.0–13.0 kg-m, 80–94 ft-lb)
Rear brake arm bolt	8–12 N·m (0.8–1.2 kg-m, 6–9 ft-lb)
Rear brake stopper bolt	10–14 N·m (1.0–1.4 kg-m, 7–10 ft-lb)
Rear shock absorber:	
upper mounting bolt	24–30 N·m (2.4–3.0 kg-m, 17–22 ft-lb)
lower mounting nut	35–45 N·m (3.5–4.5 kg-m, 25–33 ft-lb)
lower mounting bolt	24–30 N·m (2.4–3.0 kg-m, 17–22 ft-lb)
lower stud bolt	40–50 N·m (4.0–5.0 kg-m, 29–36 ft-lb)
damper lock nut	20–35 N·m (2.0–3.5 kg-m, 14–25 ft-lb) Apply a locking agent
Wheel hub nut	28–32 N·m (2.8–3.2 kg-m, 20–23 ft-lb) Apply oil to the thread
Exhaust muffler clamp bolt	20–30 N·m (2.0–3.0 kg-m, 14–22 ft-lb)
Exhaust muffler mounting bolt	32–38 N·m (3.2–3.8 kg-m, 23–27 ft-lb)

TOOLS

Special	
Spring attachments	07967–VM50100
Common	
Shock absorber compressor	07959--3290001
Driver	07749–0010000
Attachement, 42 x 47 mm	07746–0010300
Pilot, 17 mm	07746–0040400

TROUBLESHOOTING

Rear wheel wobbling

- Bent rim
- Faulty tire
- Axle not tightened properly

Soft suspension

- Weak shock absorber spring
- Damper oil leak

Brake squeaks

- Worn brake linings
- Foreign matter on linings
- Rough brake drum

Poor brake performance

- Brake not adjusted properly
- Contaminated brake linings
- Worn brake linings
- Worn brake shoes at cam
- Worn brake cam
- Worn brake drum
- Improper engagement between brake arm and cam-shaft serrations

EXHAUST MUFFLER

REMOVAL

Remove the seat (page 13-2).
Loosen the exhaust muffler clamp bolt.

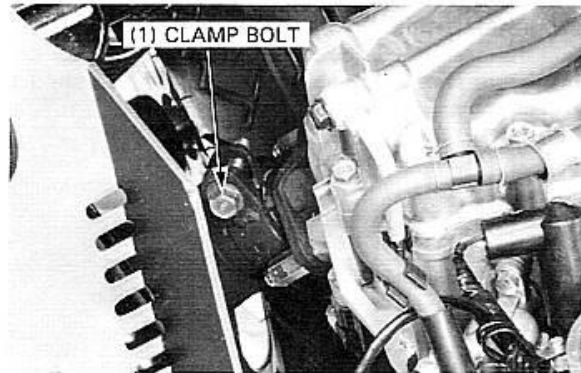

Remove the four exhaust muffler mounting bolts and exhaust muffler.

INSTALLATION

Insert the exhaust muffler into the exhaust pipe.
Loosely install the exhaust muffler mounting bolts.
Tighten the exhaust muffler clamp bolt.

TORQUE: 20–30 N·m (2.0–3.0 kg-m, 14–22 ft-lb)

Tighten the exhaust muffler mounting bolts.

TORQUE: 32–38 N·m (3.2–3.8 kg-m, 23–27 ft-lb)

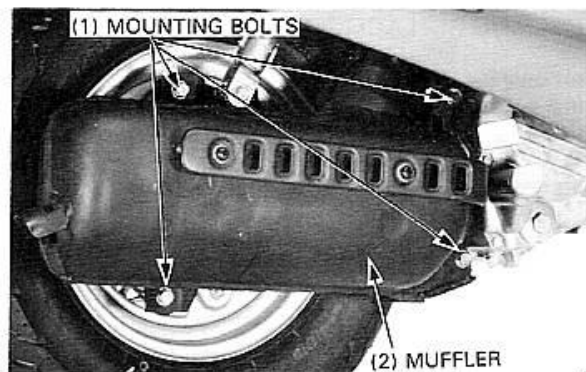

REAR WHEEL

REMOVAL

Remove the exhaust muffler.
Remove the right rear shock absorber (page 15-8).
Remove the rear axle nut, collar B, swingarm and collar A.

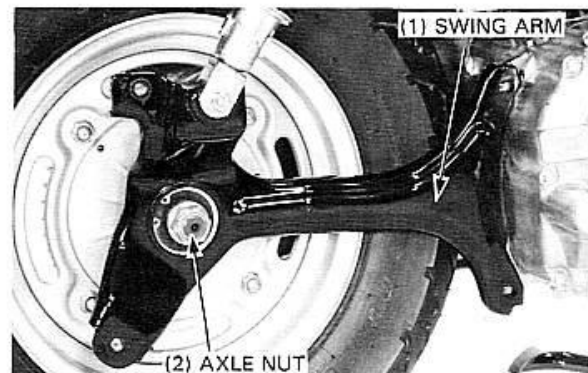

INSPECTION

WHEEL RIM

Place the rear wheel in a truing stand.
Spin the rear wheel by hand and measure the rim runout using a dial indicator.

SERVICE LIMIT: AXIAL/RADIAL: 2.0 mm (0.08 in)

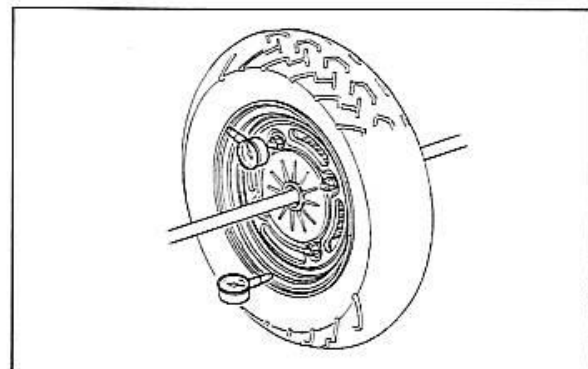

REAR WHEEL/BRAKE/SUSPENSION

SWINGARM BEARING

Turn the inner race of the swingarm bearing with your finger. The bearing should turn smoothly and quietly. Also check that the bearing outer race fits tightly in the swingarm.

Remove and discard the bearing if the race does not turn smoothly, quietly, or if it fits loosely in the swingarm.

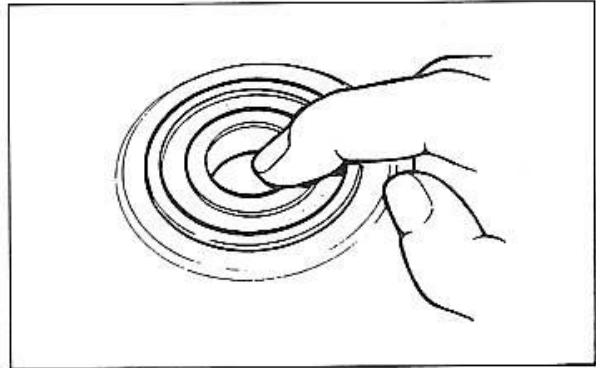

BEARING REPLACEMENT

Remove the side collar B from the swingarm.
Remove the snap ring and dust seal from the swingarm.
Drive the swingarm bearing out of the swingarm.

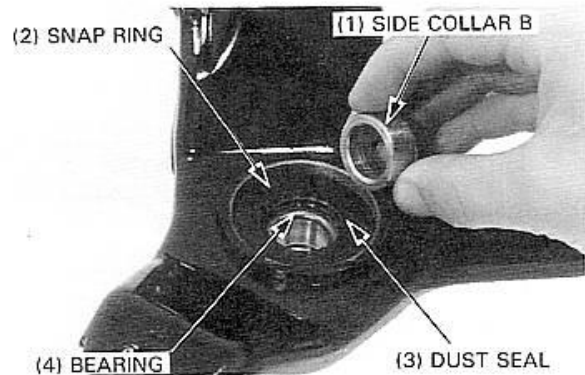

Drive a new bearing into the swingarm.

TOOLS:

Driver	07749-0010000
Attachment, 42 x 47 mm	07746-0010300
Pilot, 17 mm	07746-0040400

NOTE

- Do not allow the bearing to tilt while driving it in.
- Never reinstall an old bearing, once a bearing is removed, it must be replaced with a new one.

Apply grease to the new dust seal lips and install it over the bearing.

DISASSEMBLY

Remove the four wheel hub nuts and separate the wheel hub from the rim.
Disassemble the rear wheel.

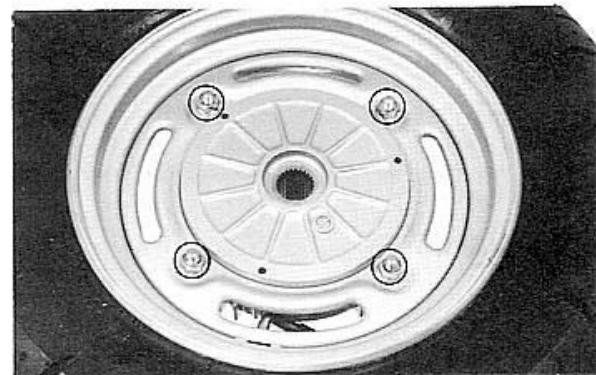
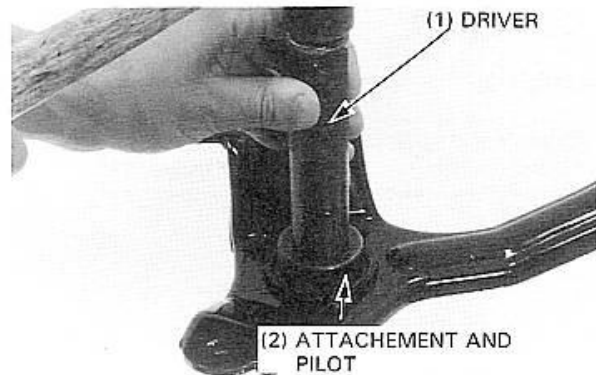

ASSEMBLY

Install the air valve as shown in the illustration below.

NOTE

- For optimum balance, the tire balance mark (a paint dot on the side wall) must be located next to the valve stem. Remount the tire if necessary

Coat the threads of the wheel hub nuts with oil, and install the wheel hub onto the rim, then tighten the wheel hub nuts.

TORQUE: 28–32 N·m (2.8–3.2 kg·m, 20–23 ft·lb)

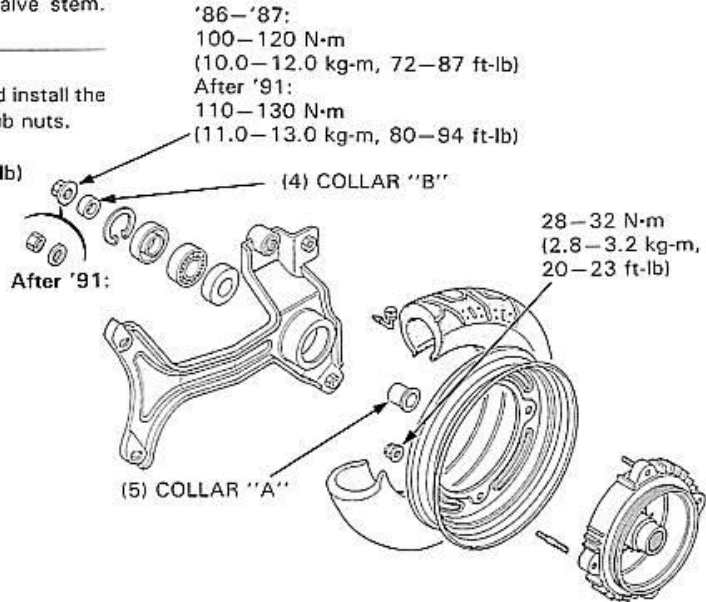
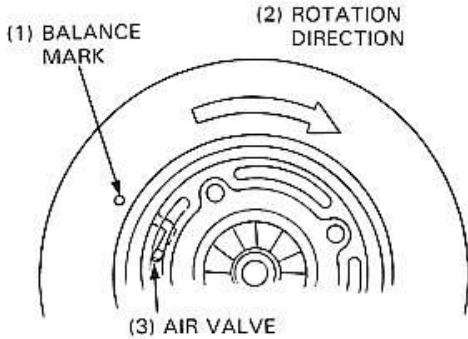

INSTALLATION

Install the rear wheel.
 Install the collar "A" over the final drive shaft.
 Install the swingarm.

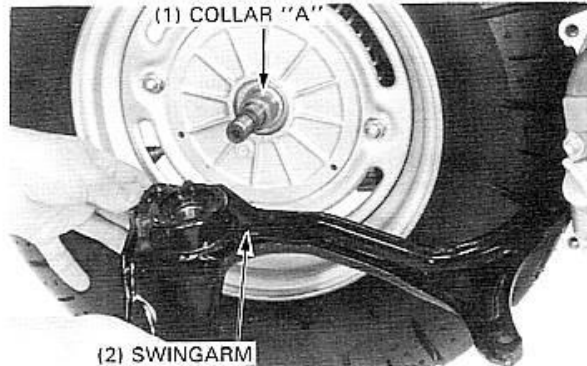

Install the collar "B".
 Install the washer (After '91 only) and rear axle nut.
 Tighten the axle nut.

TORQUE:
 '86-'87: 100–120 N·m (10.0–12.0 kg·m, 72–87 ft·lb)
 After '91: 110–130 N·m (11.0–13.0 kg·m, 80–94 ft·lb)

Install the right rear shock absorber (page 15-9).
 Install the exhaust muffler (page 15-2).

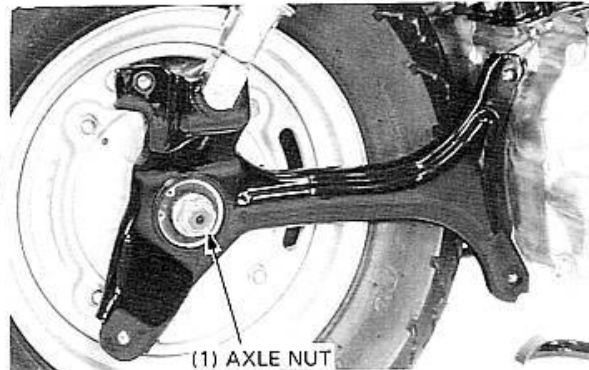

REAR WHEEL/BRAKE/SUSPENSION

REAR BRAKE

Remove the rear wheel (page 15-2).

INSPECTION

BRAKE DRUM

Measure the rear brake drum I.D.

SERVICE LIMIT: 131.0 mm (5.16 in)

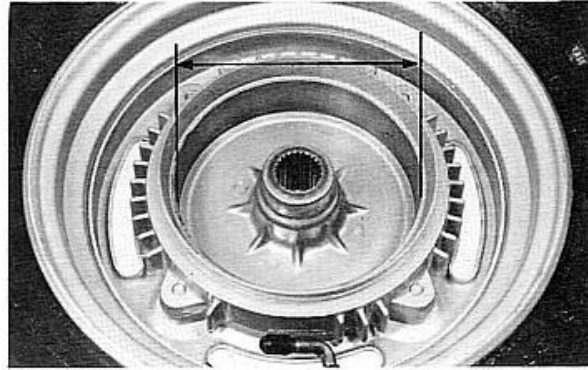

BRAKE LINING

Measure the rear brake lining thickness.

SERVICE LIMIT: 2.0 mm (0.08 in)

WARNING

- *Keep grease off the brake linings. Wipe off excess grease.*

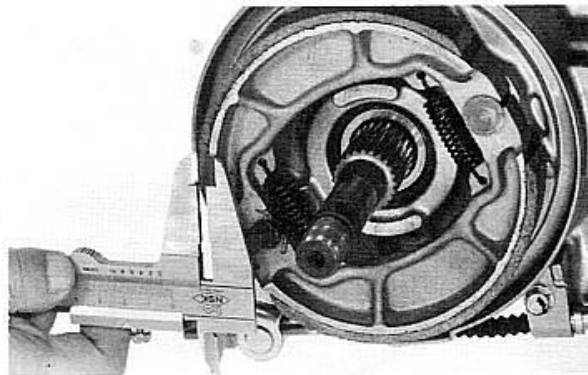

DISASSEMBLY

- Remove the rear brake cable clamp bolt and clamp.
- Remove the brake cable from the brake arm by removing the brake adjuster.
- Remove the brake shoes.
- Remove the brake arm bolt and remove the brake arm from the brake cam.
- Remove the brake cam.

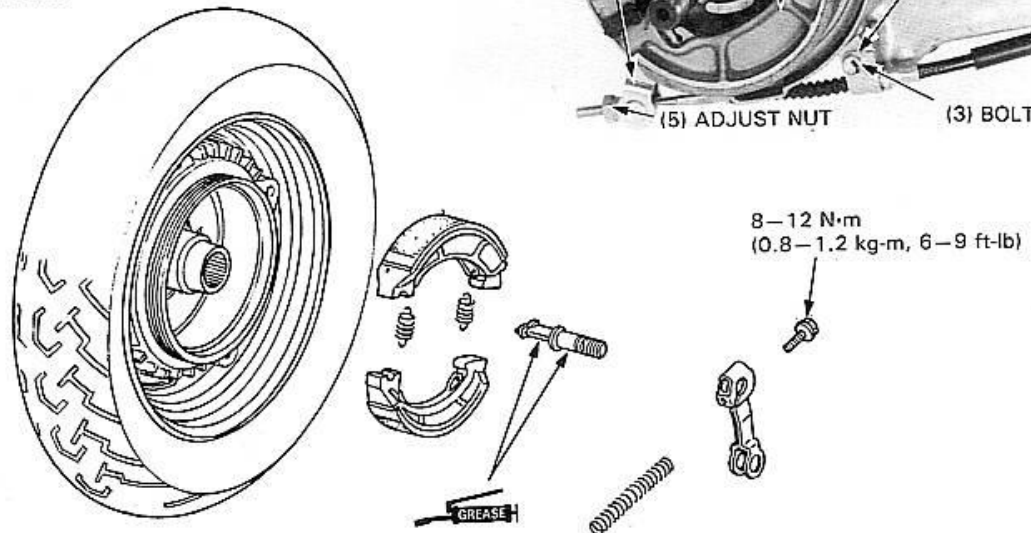
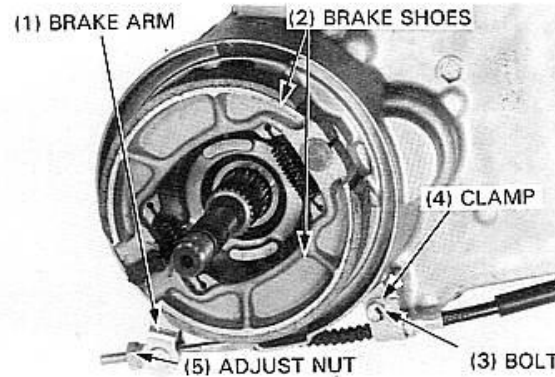

ASSEMBLY

Apply grease sparingly at the point where the brake shoes will contact the anchor pin.
 Apply grease to the brake cam and install it.
 Apply grease to the dust seal lip.

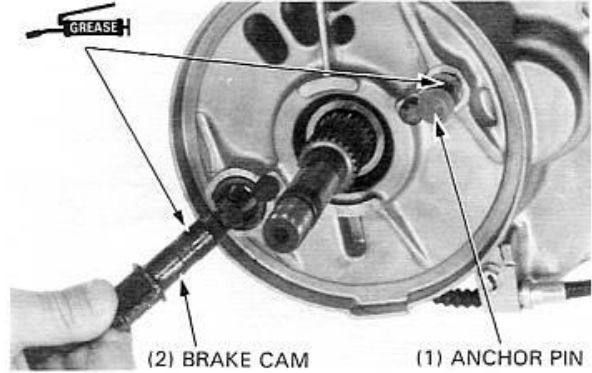

Install the brake arm onto the brake cam aligning the punch marks on the brake cam and brake arm.

Tighten the brake arm bolt.

TORQUE: 8–12 N·m (0.8–1.2 kg·m, 6–9 ft·lb)

Install the brake arm return spring.

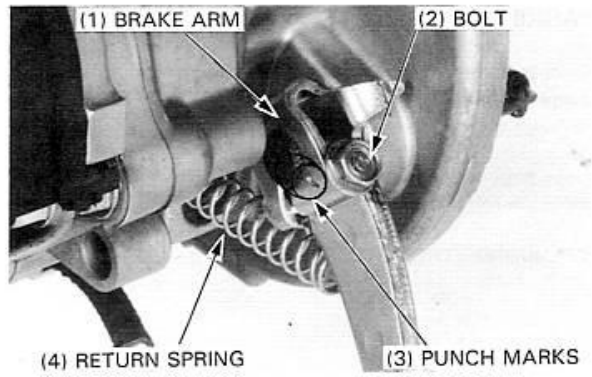

Install the brake shoes.
 Connect the brake cable to the brake arm.
 Install the rear wheel (page 15-4).
 Adjust the rear brake free play (page 3-11).

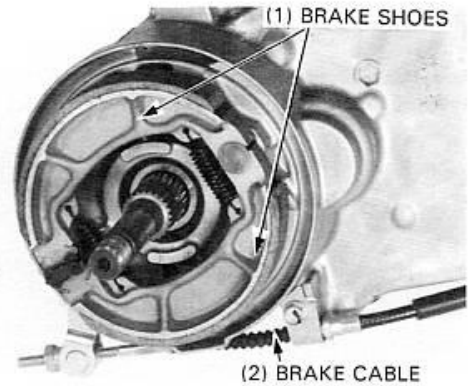

**REAR BRAKE PEDAL/
 BRAKE LOCK SYSTEM**

REAR BRAKE PEDAL REMOVAL/INSTALLATION

- Remove the following:
- the rear covers (page 13-2)
 - the side rails (page 13-5)
 - the floor panel (page 13-8)
 - the brake pedal spring.

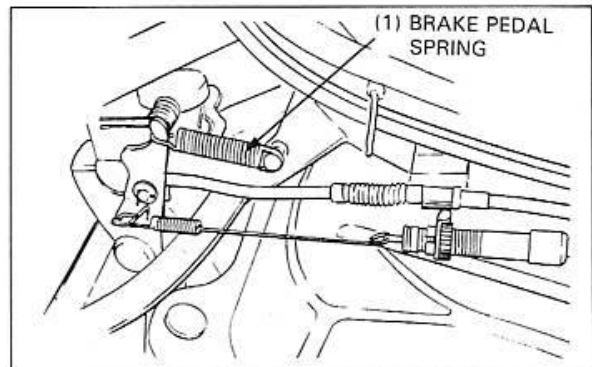

REAR WHEEL/BRAKE/SUSPENSION

Remove the brake pedal bolt and brake pedal.

Install the brake pedal in the reverse order of removal.

NOTE

- Apply grease to each sliding surface.
- Align the punch mark on the brake pedal with the punch mark on the brake pedal spindle.

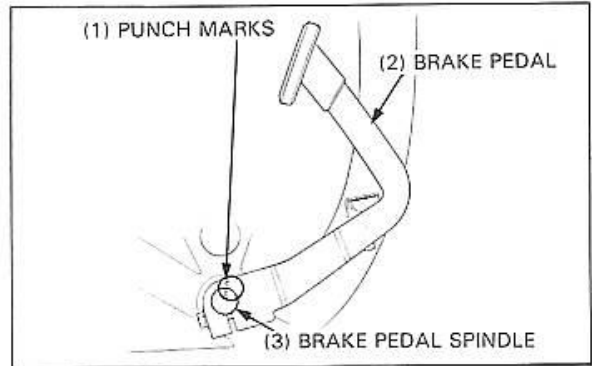

PARKING BRAKE LOCK INSPECTION

Remove the front inner fender B by removing the four screws (page 13-6).

Remove the parking brake lock cover.

Press the brake pedal, pull the parking brake lever and measure the push rod stroke.

STANDARD STROKE: 11–12 mm (7/16–1/2 in)

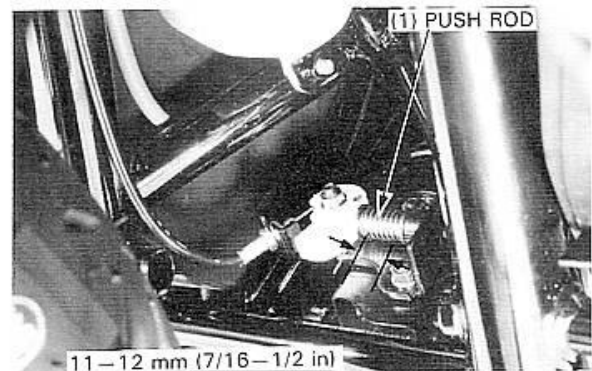

PARKING BRAKE ADJUSTMENT

Loosen the rear brake adjuster at the rear wheel to obtain more than 60 mm (2-3/8 in) of brake pedal free play.

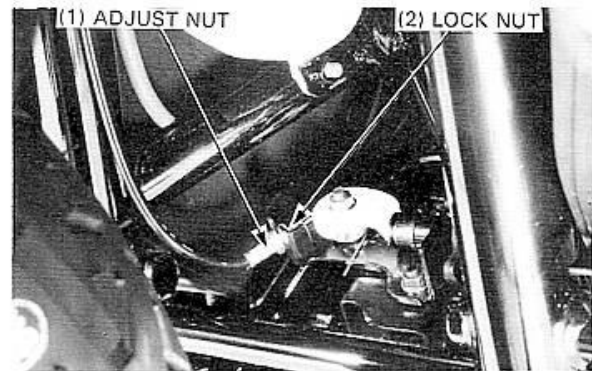

Depress the brake pedal and pull the brake lock lever. Adjust the parking brake by loosening the lock nut and turning the adjuster so that the index line on the cam aligns with the index mark on the base plate.

Tighten the lock nut.

Adjust the rear brake pedal free play (page 3-11).

Assemble in the reverse order of disassembly.

NOTE

- Apply grease to the push rod, cam and pin.

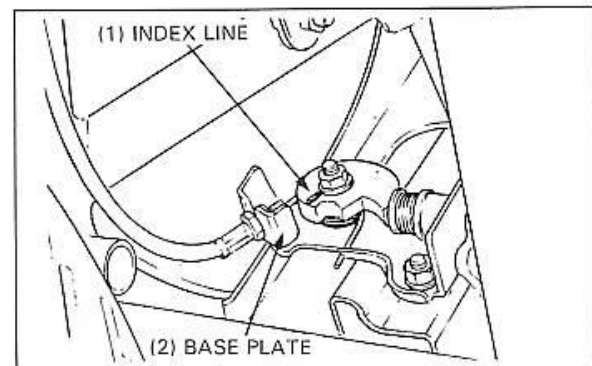

REAR SHOCK ABSORBER

REMOVAL

Remove the seat (page 13-2).
 Remove the rear shock absorber upper and lower mounting bolts and nuts.
 Remove the rear shock absorber.

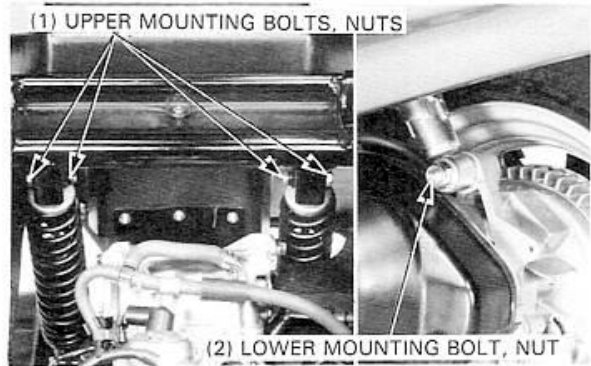

DISASSEMBLY

Set the shock absorber in the compressor as shown and compress the spring 30 mm by turning the compressor handle.

TOOLS:

Shock absorber compressor	07959-3290001
Spring attachment	07967-VM50100

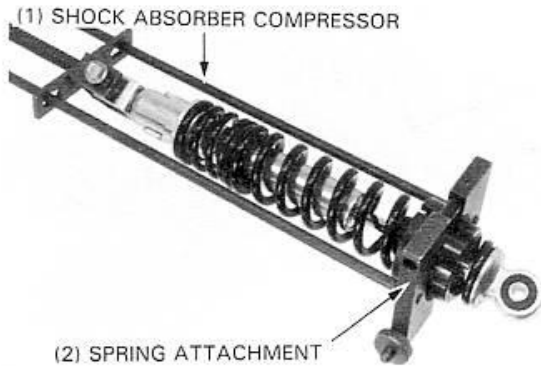

Pull the damper rod out.
 Loosen the lock nut and remove the upper joint and lock nut.
 Remove the upper spring, spring seat, lower spring, spring adjuster and stopper rubber.

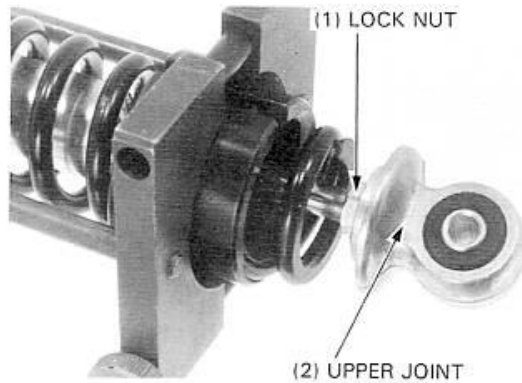

INSPECTION

Measure the rear shock absorber spring free length.

SERVICE LIMITS: '86: Upper spring: 187.9 mm (7.40 in)
 Lower spring: 41.7 mm (1.64 in)
 After '86: 232.1 mm (9.14 in)

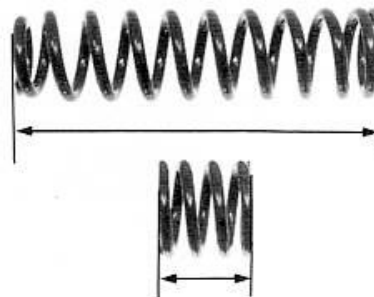

REAR WHEEL/BRAKE/SUSPENSION

ASSEMBLY

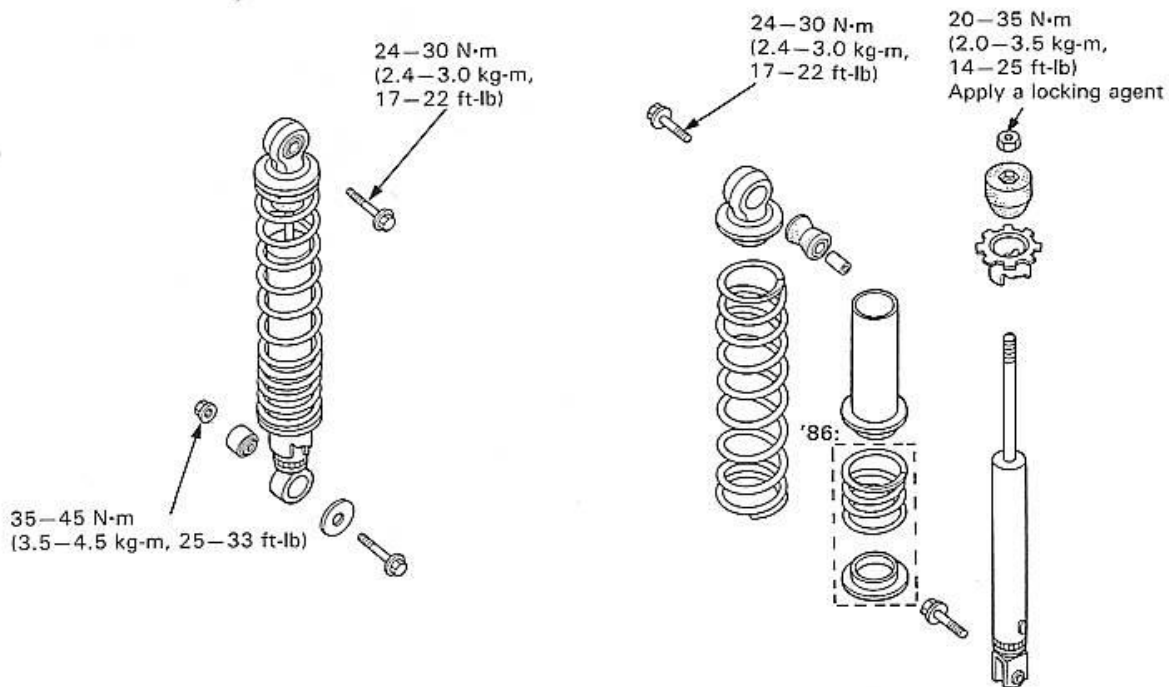

NOTE

- Install the upper spring on the shock absorber with the small coil end facing the top.
- Apply locking agent to the lock nut threads before installation.

Install the lock nut and upper joint and tighten the lock nut.

TORQUE: 20–35 N·m (2.0–3.5 kg-m, 14–25 ft-lb)

TOOLS:

Shock absorber compressor	07959–3290001
Spring attachment	07967–VM50100

INSTALLATION

Install the right and left rear shock absorber and tighten the upper and lower mounting bolts and nuts.

TORQUE:

Upper:	24–30 N·m (2.4–3.0 kg-m, 17–22 ft-lb)
Left lower:	35–45 N·m (3.5–4.5 kg-m, 25–33 ft-lb)
Right lower:	24–30 N·m (2.4–3.0 kg-m, 17–22 ft-lb)

NOTE

- Make sure that the spring adjusters of the rear shock absorbers are same positions.

Check the operation of the shock absorbers by using your weight to compress them a few times.

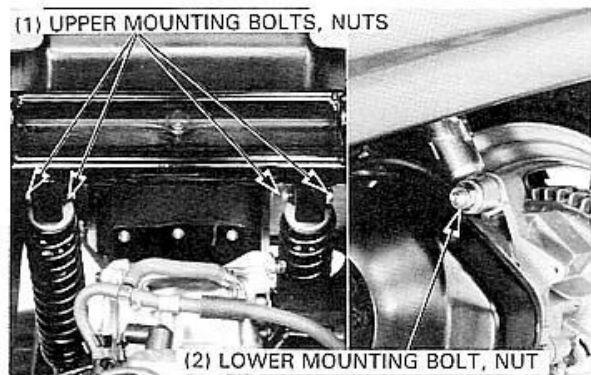
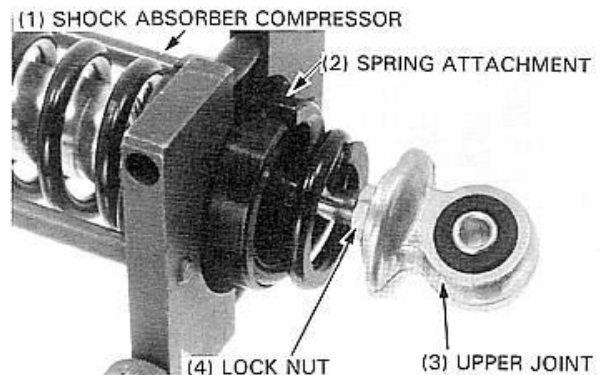

HYDRAULIC BRAKE

'86-'87, '92-'93:

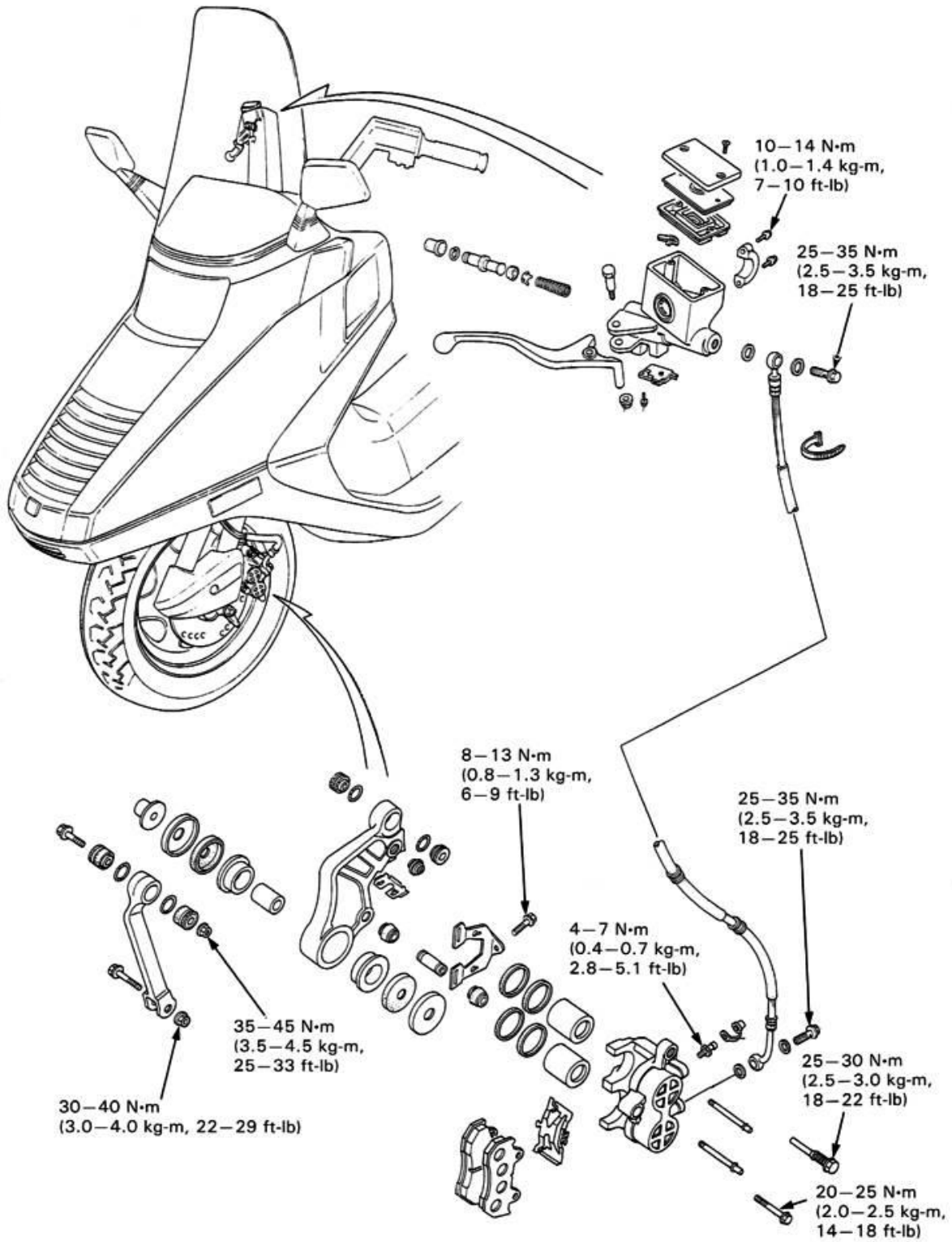

16. HYDRAULIC BRAKE

After '93:

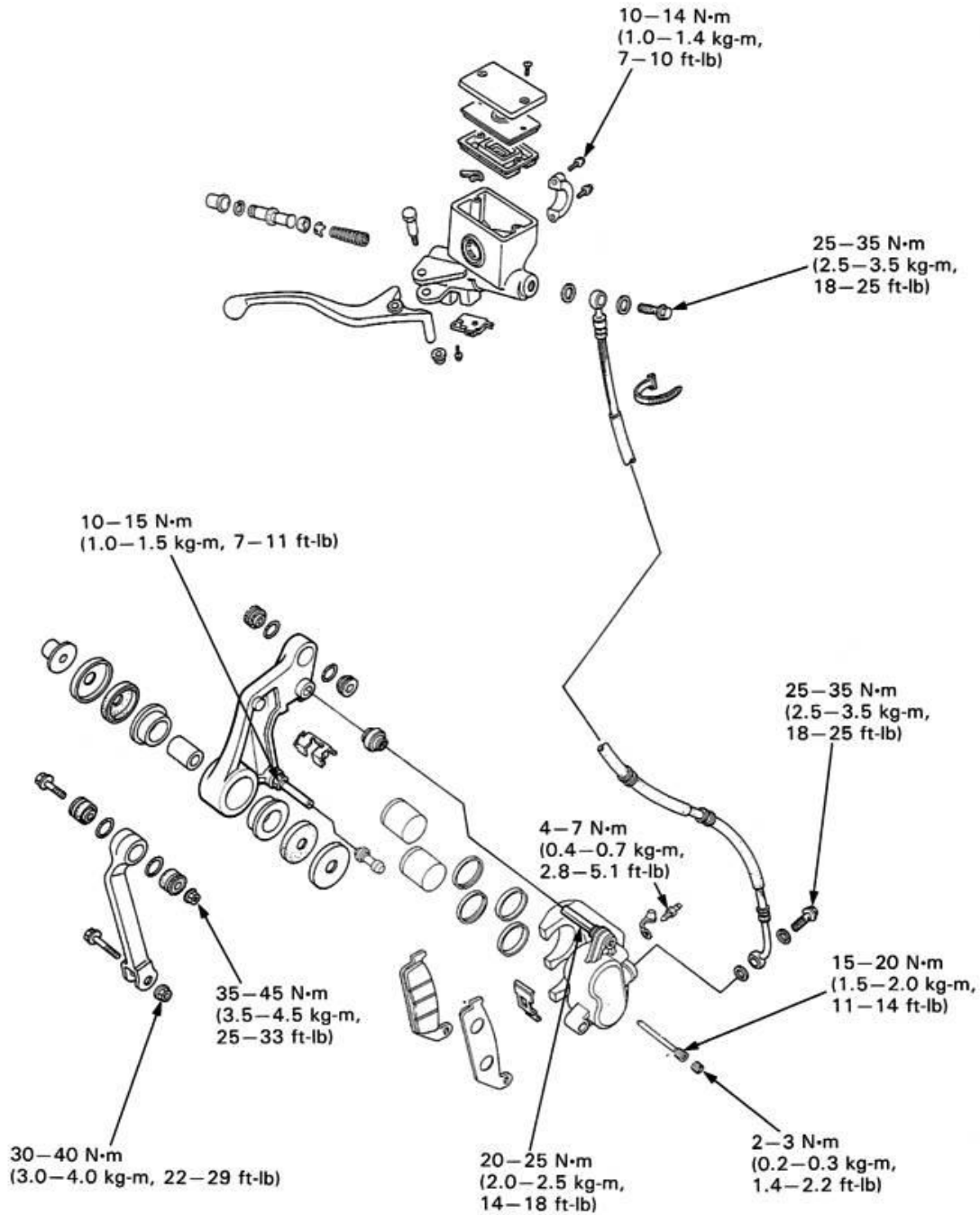

HYDRAULIC BRAKE

SERVICE INFORMATION	16-2	BRAKE DISC	16-8
TROUBLESHOOTING	16-3	BRAKE MASTER CYLINDER	16-9
BRAKE FLUID REPLACEMENT/BLEEDING	16-4	BRAKE CALIPER	16-11
BRAKE PAD REPLACEMENT	16-5		

SERVICE INFORMATION

GENERAL

- The brake calipers can be removed without disconnecting the hydraulic system.
- Bleed the hydraulic system if it has been disassembled or if the brake feels spongy.
- Do not allow foreign material to enter the system when filling the reservoir.
- Brake fluid will damage painted, plastic and rubber parts. Whenever handling brake fluid, protect the painted, plastic and rubber parts by covering them with a rag. If fluid does get on these parts, wipe it off with a clean cloth.
- Always check brake operation before riding the motorcycle.

SPECIFICATIONS

Unit: mm (in)

ITEM	STANDARD	SERVICE LIMIT
Front disc thickness	4.8–5.2 (0.19–0.20)	4.0 (0.16)
Front disc runout	—	0.3 (0.012)
Front master cylinder I.D.	14.000–14.043 (0.5512–0.5529)	14.06 (0.554)
Front master piston O.D.	13.957–13.984 (0.5495–0.5506)	13.95 (0.549)
Front caliper piston O.D.	'86–'87, '92–'93:	26.918–26.968 (1.0598–1.0617)
	After '93:	26.935–26.968 (1.0604–1.0617)
Front caliper cylinder I.D.	27.000–27.050 (1.0630–1.0650)	27.06 (1.065)

TORQUE VALUES

Bleed valve	4–7 N·m (0.4–0.7 kg-m, 28–51 ft-lb)
Caliper pin bolt ('86–'87, '92–'93)	25–30 N·m (2.5–3.0 kg-m, 18–22 ft-lb)
Caliper pin bolt (After '93)	25–30 N·m (2.5–3.0 kg-m, 18–22 ft-lb) Apply a locking agent
Caliper bracket pin bolt (After '93)	10–15 N·m (1.0–1.5 kg-m, 7–11 ft-lb) Apply a locking agent
Caliper mounting bolt ('86–'87, '92–'93)	20–25 N·m (2.0–2.5 kg-m, 14–18 ft-lb)
Pad pin retainer bolt ('86–'87, '92–'93)	8–13 N·m (0.8–1.3 kg-m, 6–9 ft-lb)
Pad pin (After '93)	15–20 N·m (1.5–2.0 kg-m, 11–14 ft-lb)
Pad pin plug (After '93)	2–3 N·m (0.2–0.3 kg-m, 1.4–2.2 ft-lb)
Master cylinder holder bolt	10–14 N·m (1.0–1.4 kg-m, 7–10 ft-lb)
Brake oil bolt	25–35 N·m (2.5–3.5 kg-m, 18–25 ft-lb)
Torque link nut:	
Front fork side	35–45 N·m (3.5–4.5 kg-m, 25–33 ft-lb)
Caliper bracket side	30–40 N·m (3.0–4.0 kg-m, 22–29 ft-lb)

TOOL

Special	
Snap ring pliers	07914–3230001

TROUBLESHOOTING

Brake lever soft or spongy

- Air bubbles in hydraulic system
- Low fluid level
- Hydraulic system leaking

Brake lever too hard

- Sticking piston(s)
- Clogged hydraulic system
- Pads glazed or excessively worn

Brake drag

- Hydraulic system sticking
- Sticking piston(s)

Brakes grab or pull to one side

- Pads contaminated
- Disc or wheel misaligned

Brake chatter or squeal

- Pads contaminated
- Excessive disc runout
- Caliper installed incorrectly
- Disc or wheel misaligned

HYDRAULIC BRAKE

BRAKE FLUID REPLACEMENT/BLEEDING

BRAKE FLUID DRAINING

WARNING

- *A contaminated brake disc or pad reduces stopping power. Discard contaminated pads and clean a contaminated disc with a high quality brake degreasing agent.*

CAUTION

- *Do not allow foreign material to enter the system when filling the reservoir.*
- *Avoid spilling fluid on painted, plastic, or rubber parts. Place a rag over these parts whenever the system is serviced.*

With the fluid reservoir parallel to the ground, remove the reservoir cap and diaphragm plate.

Connect a hose to the bleed valve.

Loosen the caliper bleed valve and pump the brake lever until no more fluid flows out of the bleed valve. Close the bleed valve.

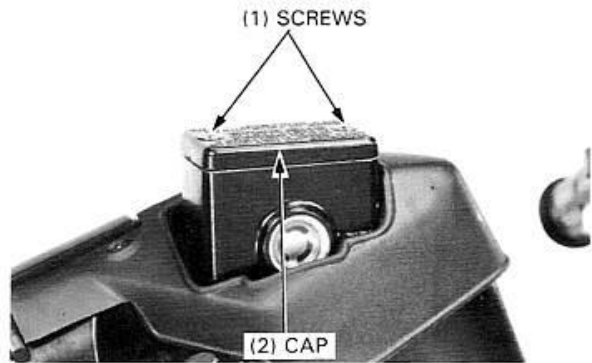

BRAKE FLUID FILLING/BLEEDING

Fill the reservoir with DOT-3 or 4 brake fluid from a sealed container.

CAUTION

- *Do not mix different types of fluid. They are not compatible.*

Connect a commercially available brake bleeder to the bleed valve.

Pump the brake bleeder and loosen the bleed valve.

Add fluid when the fluid level in the master cylinder reservoir is low.

NOTE

- Check the fluid level often while bleeding the brakes to prevent air from being pumped into the system.
- When using a brake bleeding tool, follow the manufacturer's operating instructions.
- If air is entering the bleeder from around the bleed valve threads, seal the threads with teflon tape.

Repeat the above procedures until air bubbles do not appear in the plastic hose.

Close the bleed valve and operate the brake lever. If it feels spongy, bleed the system by performing the BLEEDING procedure.

If a brake bleeder is not available, perform the following procedure: Pump up the system pressure with the lever until there are no air bubbles in the fluid flowing out of the reservoir small hole and lever resistance is felt.

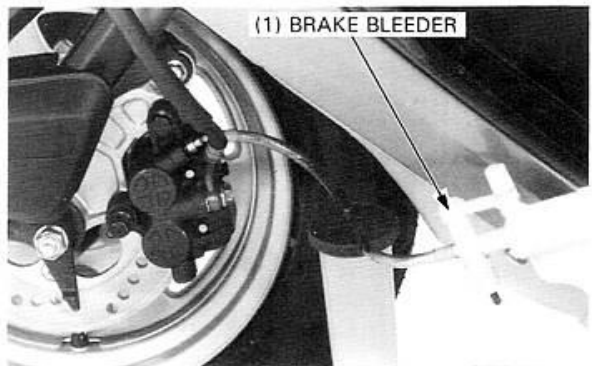
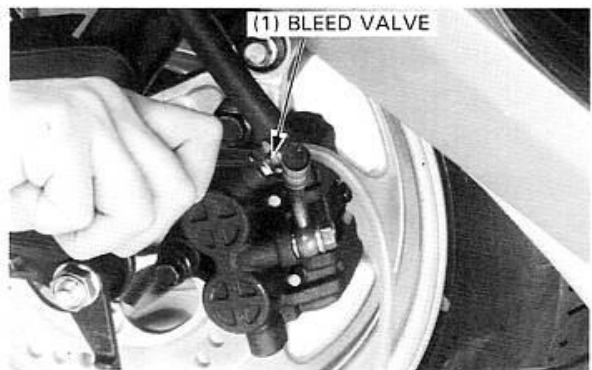

1. Squeeze the brake lever and hold it down, then open the bleed valve 1/2 turn and then close the valve.

NOTE

- Do not release the brake lever until the bleed valve has been closed.

2. Release the brake lever slowly and wait several seconds after it reaches the end of its travel.

Repeat steps 1 and 2 until bubbles cease to appear in the fluid coming out of the bleeder valve.
Tighten the bleed valve.

TORQUE: 4–7 N·m (0.4–0.7 kg·m, 2.8–5.1 ft·lb)

Fill the fluid reservoir to the upper level mark.

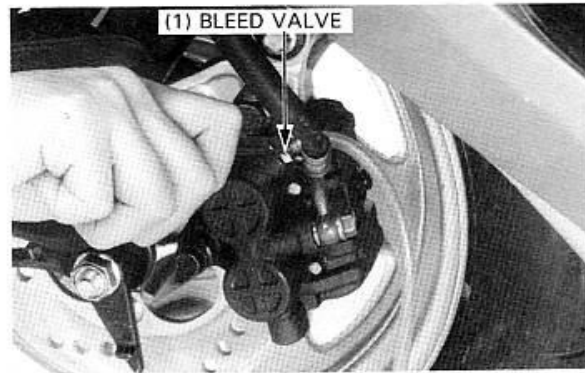

(1) UPPER LEVEL MARK



Reinstall the diaphragm, diaphragm plate and reservoir cap.

WARNING

- *A contaminated brake disc or pad reduces stopping power. Discard contaminated pads and clean a contaminated disc with a high quality brake degreasing agent.*

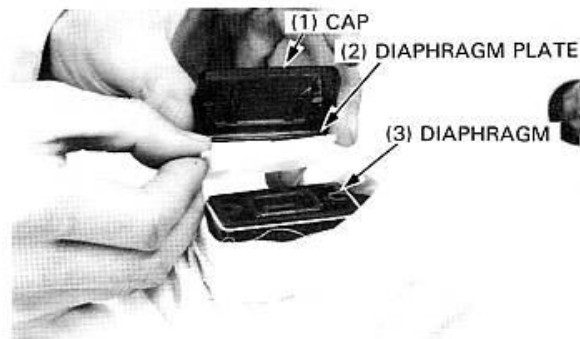

BRAKE PAD REPLACEMENT

NOTE

- Always replace the brake pads in pairs to assure even disc pressure.

'86–'87, '92–'93:

Loosen the pad pin retainer bolt.
Remove the caliper pin bolt and caliper mounting bolt.
Remove the caliper from the caliper bracket.

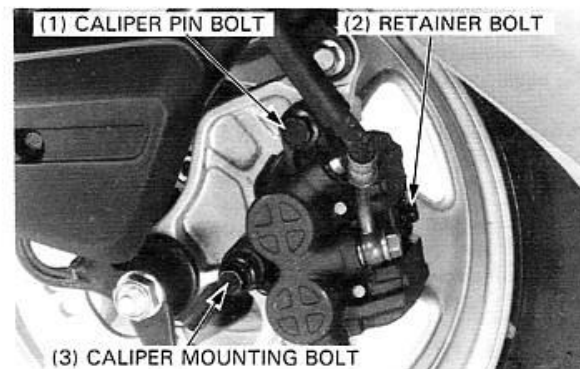

HYDRAULIC BRAKE

Remove the pad pin retainer bolt and retainer.

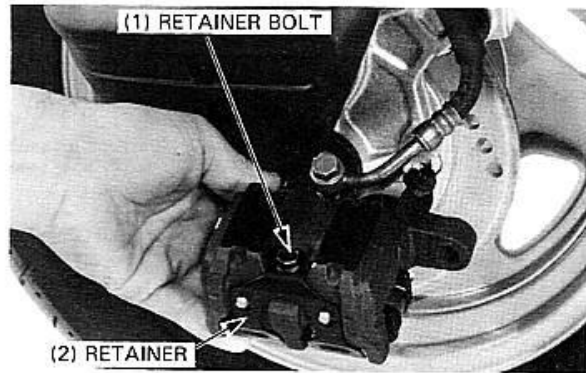

Pull the pad pins out of the caliper.
Remove the brake pads.

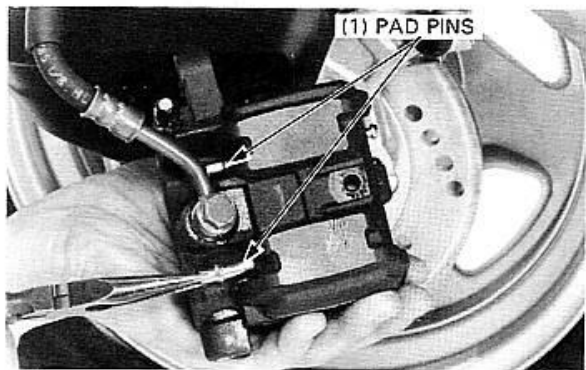

Make sure that the pad spring is installed in the position shown.

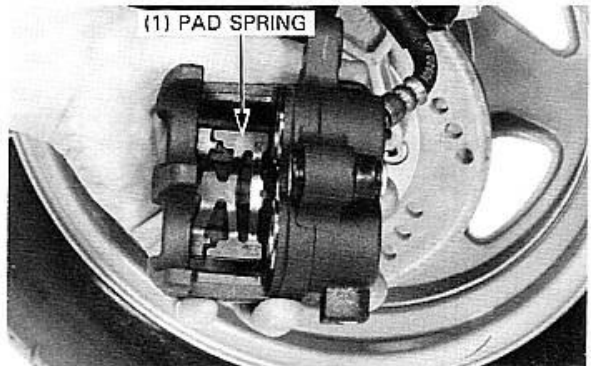

Install new pads in the caliper.
Install one pad pin first, then install the other pin by pushing the pads against the caliper to depress the pad spring.

Push the caliper pistons all the way.

CAUTION

- *Be careful that the master cylinder does not overflow when the caliper pistons are compressed.*
- *Brake fluid can cause damage to painted, plastic, or rubber surfaces.*

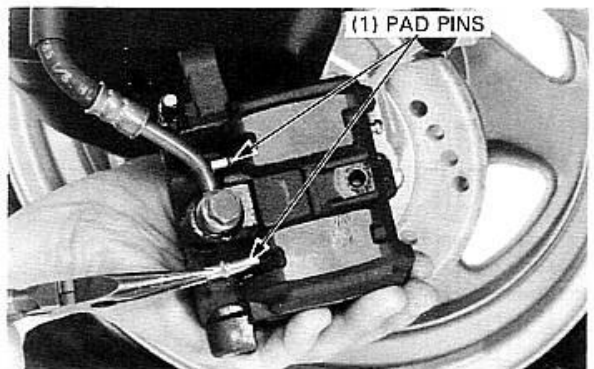

Place the pad pin retainer over the pad pins.
Push the retainer down to secure the pins.
Loosely install the pad pin retainer bolt.

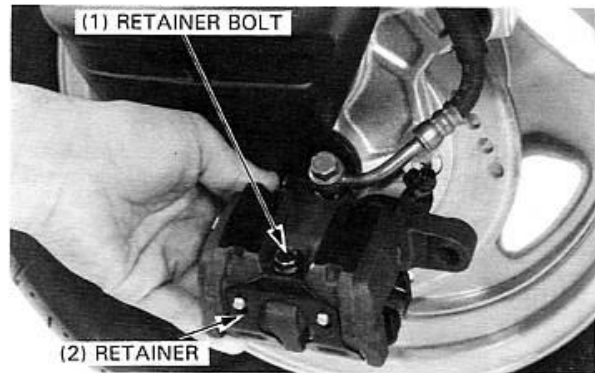

Apply silicone grease to the inside of the caliper pin bolt boot.
Make sure that the retainer clip is in position on the caliper bracket.

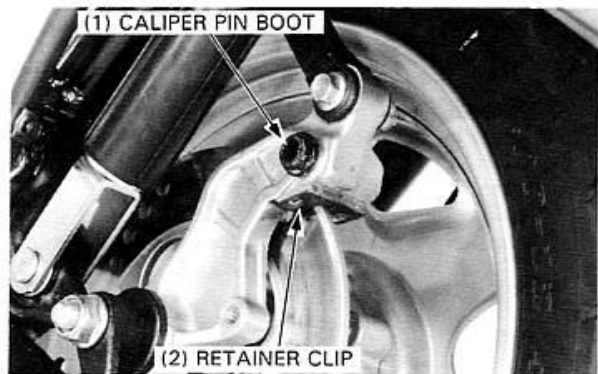

Install the caliper to the caliper bracket so that the disc is positioned between the pads, being careful not to damage the pads.

Install the caliper pin bolt and tighten it.

TORQUE: 25–30 N·m (2.5–3.0 kg-m, 18–22 ft-lb)

Install the caliper mounting bolt and tighten it.

TORQUE: 20–25 N·m (2.0–2.5 kg-m, 14–18 ft-lb)

Tighten the pad pin retainer bolt.

TORQUE: 8–13 N·m (0.8–1.3 kg-m, 6–9 ft-lb)

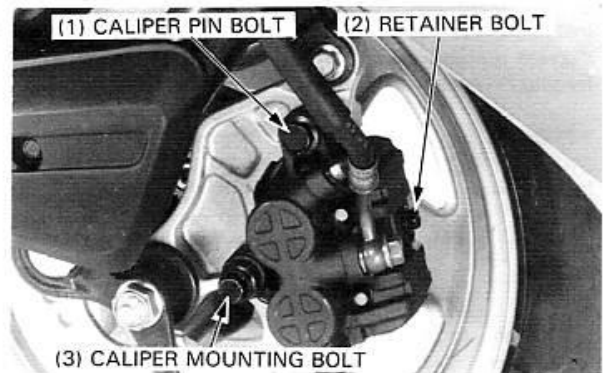

NOTE

- Operate the brake lever to seat the caliper pistons against the pads.

HYDRAULIC BRAKE

After '93:

The brake disc can be replaced with the caliper installed.

NOTE

- Push the pistons all the way in to provide clearance the new pads.

CAUTION

- *Be careful that the master cylinder does not overflow when the caliper pistons are compressed.*
- *Brake fluid can cause damage to painted, plastic or rubber surfaces.*

Remove the pad pin plug and loosen the pad pin.
Pull the pad pin out of the caliper.

Remove the brake pads.

Install the new pads in the caliper.

Make sure that the pad spring is installed in the position shown.

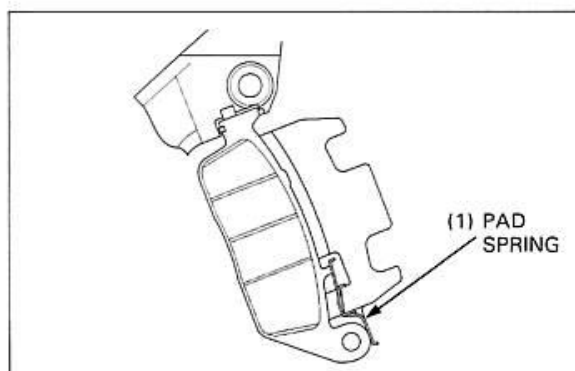
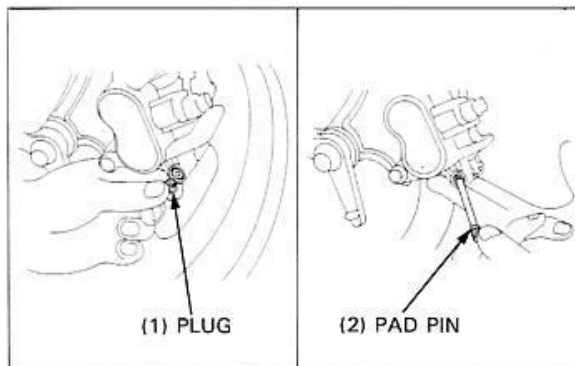

Install the pad pin by pushing the pads against the caliper to depress the pad spring. Tighten the pad pin to the specified torque.

TORQUE: 15–20 N·m (1.5–2.0 kg-m, 11–14 ft-lb)

Install the pad pin plug and tighten to the specified torque.

TORQUE: 2–3 N·m (0.2–0.3 kg-m, 1.4–2.2 ft-lb)

NOTE

- Operate the brake lever to seat the caliper pistons against the pads.

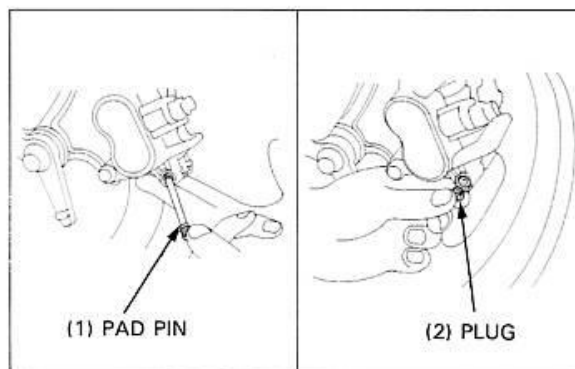

BRAKE DISC

INSPECTION

Measure the brake disc thickness with a micrometer.

SERVICE LIMIT: 4.0 mm (0.16 in)



Remove the brake disc from the front wheel (page 14-8).
Measure the brake disc for warpage.

SERVICE LIMIT: 0.30 mm (0.012 in)



BRAKE MASTER CYLINDER

REMOVAL

Remove the master cylinder cover, handlebar upper and lower covers (page 14-3).
Drain the brake fluid from the hydraulic system (page 16-4).
Disconnect the brake light switch wires from the switch.
Remove the brake hose from the master cylinder.

CAUTION

- *Avoid spilling fluid on the painted, plastic, or rubber parts. Place a rag over these parts whenever the system is serviced.*
- *When removing the oil bolt, cover the end of the hose to prevent contamination.*

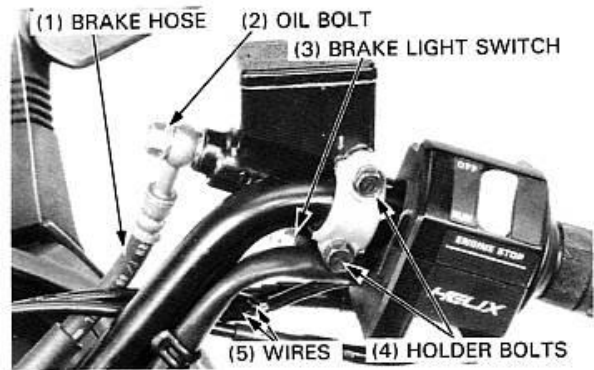

Remove the master cylinder holder bolts and master cylinder.

DISASSEMBLY

Remove the brake lever pivot bolt, nut and the lever.
Remove the brake light switch.

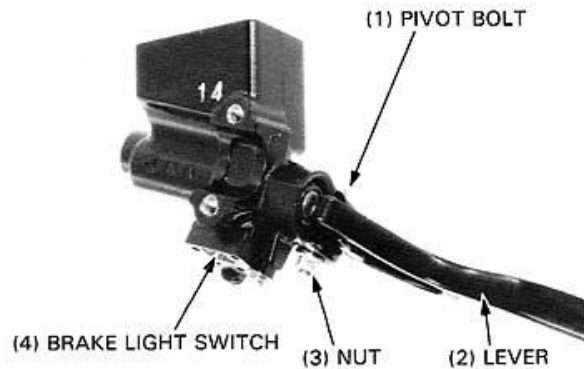

Remove the piston boot and snap ring from the master cylinder body.

TOOL:

Snap ring pliers

07914-3230001

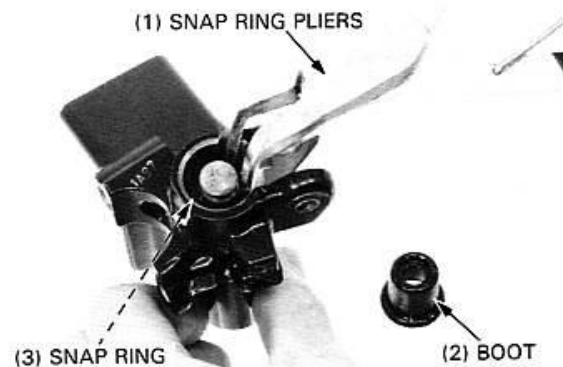

HYDRAULIC BRAKE

Remove the secondary cup and piston then remove the primary cup and spring.

Clean the inside of the master cylinder and reservoir with brake fluid.

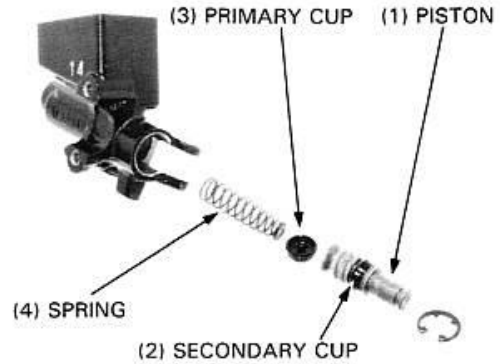

INSPECTION

Check the primary and secondary cups for wear or damage.

Check the piston for scratches, scoring or other damage.
Measure the piston O.D.

SERVICE LIMIT: 13.95 mm (0.549 in)

NOTE

- The piston, piston cups and spring must be replaced as a set.

Check the master cylinder for scratches, scoring or other damage.

Measure the master cylinder I.D.

SERVICE LIMIT: 14.06 mm (0.554 in)

ASSEMBLY

CAUTION

- *Keep the master cylinder piston, cylinder and spring as a set; don't substitute individual parts.*

Assemble the master cylinder. Coat all parts with clean brake fluid before assembly. Install the spring and primary cup together.

Dip the piston cup in brake fluid before assembly.

Install the piston and snap ring.

TOOL:

Snap ring pliers

07914-3230001

CAUTION

- *When installing the cups, do not allow the lips to turn inside out and be certain the snap ring is firmly seated in the groove.*

Install the piston boot.

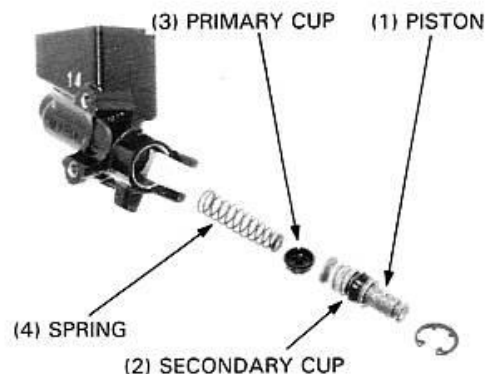
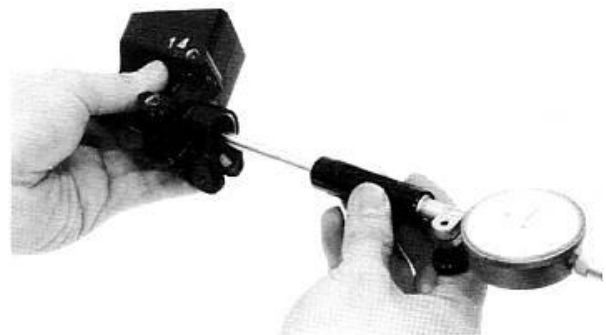

Install the brake light switch.
Install the brake lever and pivot bolt.
Tighten the pivot nut securely.

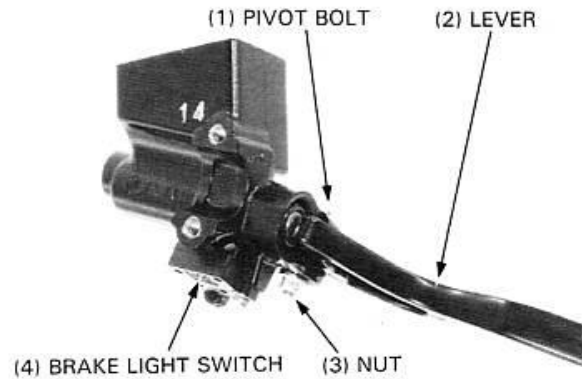

INSTALLATION

Place the brake master cylinder on the handlebar and install the holder with the "UP" mark facing up.
Align the end of the holder with punch mark on the handlebar and tighten the upper bolt first, then tighten the lower bolt.

TORQUE: 10–14 N·m (1.0–1.4 kg·m, 7–10 ft·lb)

Connect the brake hose to the master cylinder with the oil bolt and two new sealing washers.
Tighten the oil bolt.

TORQUE: 25–35 N·m (2.5–3.5 kg·m, 18–25 ft·lb)

Connect the brake light switch wires to the brake light switch.
Fill and bleed the master cylinder (page 16-4).
Install the handlebar upper and lower covers and master cylinder cover (page 14-4).

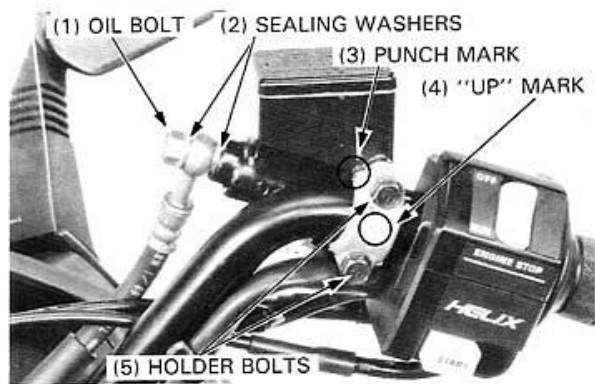

'86-'87, '92-'93:

BRAKE CALIPER

REMOVAL

Drain the brake fluid from the hydraulic system (page 16-4).
Remove the brake hose from the caliper.

CAUTION

- *Avoid spilling fluid on painted, plastic, or rubber parts. Place a rag over these parts whenever the system is serviced.*

'86-'87, '92-'93:

Loosen the pad pin retainer bolt.
Remove the caliper pin bolt and caliper mounting bolt.
Remove the caliper from the caliper bracket.
Remove the brake pads and pad spring (page 16-5).
Remove the front wheel (page 14-5).

After '93:

Remove the brake pads (page 16-8).
Remove the front wheel (page 14-5) and the caliper assembly.
Separate the caliper from the bracket.

Remove the torque link bolt from the caliper bracket then remove the caliper bracket.
Remove the torque link bolt from the front fork then remove the torque link from the front fork.

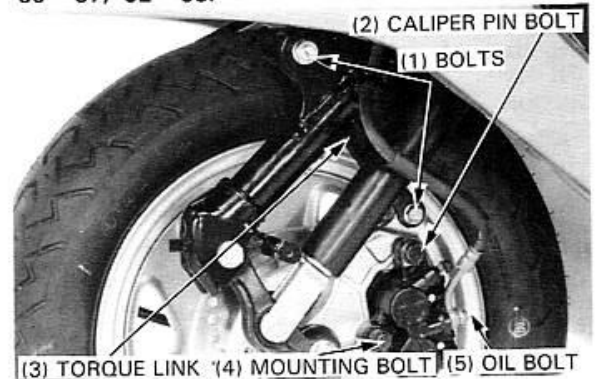

After '93:

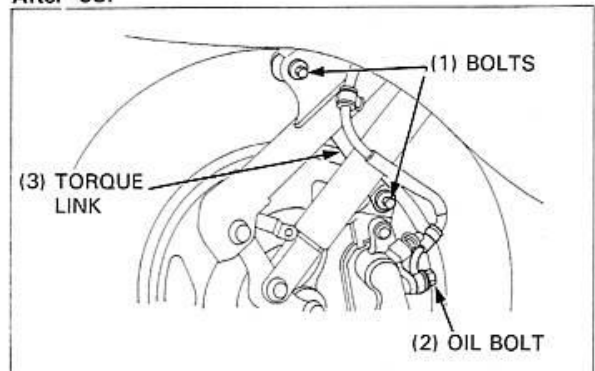

HYDRAULIC BRAKE

'86-'87, '92-'93:

Remove the pivot boots and collar.

After '93:

Remove the pivot boots.

'86-'87, '92-'93 Shown:

(1) PIVOT BOOTS

(2) COLLAR

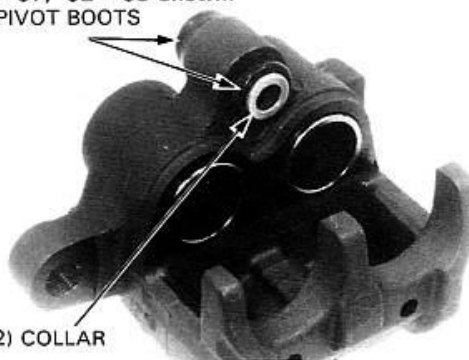

Position the caliper with the pistons down and apply small squirts of air pressure to the fluid inlet to remove the pistons.

WARNING

- *Do not use the high pressure air or bring the nozzle too close to the inlet. Place a shop towel over the pistons to prevent the pistons becoming projectiles.*



Push the dust and piston seals in and lift them out. Clean the seal groove with clean brake fluid.

CAUTION

- *Be careful not to damage the piston sliding surfaces.*

(1) PISTON SEAL

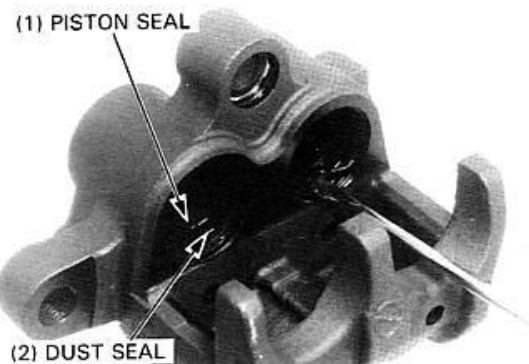

(2) DUST SEAL

INSPECTION

Check the caliper cylinders for scratches, scoring or other damage.

Measure the caliper cylinder I.D.

SERVICE LIMIT: 27.06 mm (1.065 in)



Check the pistons for scratches, scoring or other damage.
Measure the piston O.D.

SERVICE LIMIT: 26.91 mm (1.059 in)



Check the caliper pin bolt boot for deterioration or damage and replace if necessary.
Check the dust seals, collar, retainer clip, and bushings for wear or damage and replace if necessary.
Apply grease to the dust seal lips, collar and bushings.

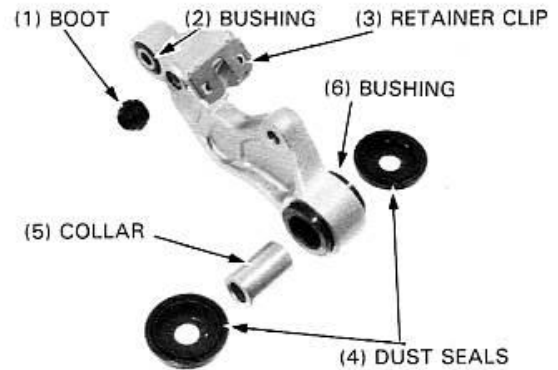

Inspect the torque link bushing for wear or damage and replace if necessary.
Apply grease to the torque link bushing.



ASSEMBLY

If the pivot collar boots are hard or have deteriorated, replace them with new ones. The dust and piston seals must be replaced with new ones whenever they are removed.

Coat the dust and piston seals with clean brake fluid and install them in the seal grooves in the caliper.

Lubricate the caliper cylinders and pistons with clean brake fluid and install the pistons into the caliper cylinders with the open ends facing the pads.

'86-'87, '92-'93:

Apply silicone grease to the pivot collar and boots.
Install the collar and boots, making sure that the boots are seated in the grooves properly.
Install the pad spring and pads (page 16-7).

'86-'87, '92-'93:

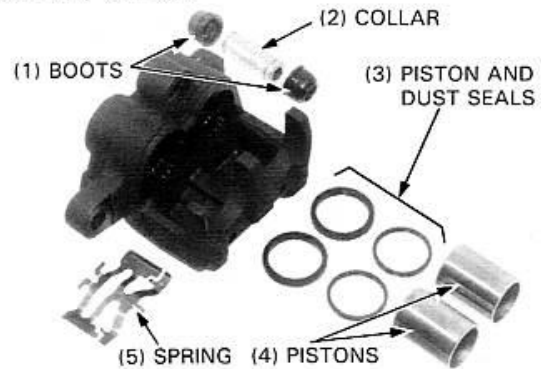

HYDRAULIC BRAKE

After '93:

Install the pad spring.

Install the pivot boots making sure they are securely seated in the caliper bracket pin grooves.

Apply silicone grease to the caliper bracket pins and assemble the caliper and bracket.

Temporarily install the brake pads with the pad pin (page 16-8).

After '93:

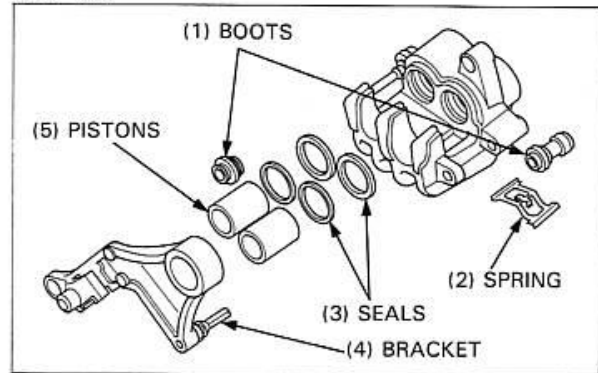

Apply grease to the bushings, collar and lip of the dust seals. Install the collar and dust seals.

Make sure that the retainer clip is in position on the caliper bracket and that the caliper pin bolt boot is in good condition. Apply silicone grease to the inside of the caliper pin boot.

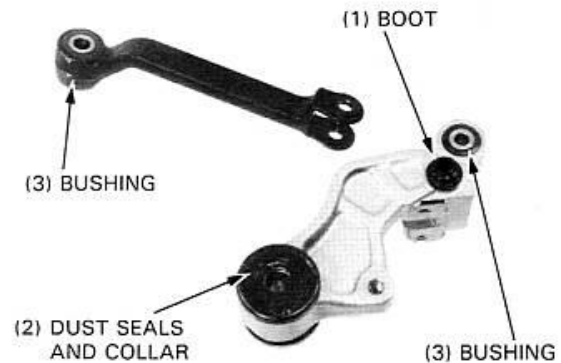

INSTALLATION

NOTE

- Use care not to damage the pads.

Install the torque link onto the front fork.

Install the caliper bracket (After '93: caliper bracket assembly) onto the torque link.

Tighten the torque link bolts.

TORQUE:

Front fork side: 35–45 N·m (3.5–4.5 kg-m, 25–33 ft-lb)

Caliper bracket side: 30–40 N·m (3.0–4.0 kg-m, 22–29 ft-lb)

Install the front wheel (page 14-9).

'86–'87, '92–'93:

Install the caliper assembly onto the caliper bracket and over the brake disc so that the disc is positioned between the pads. Apply silicone grease to the caliper pin bolt and install the caliper pin bolt.

TORQUE: 25–30 N·m (2.5–3.0 kg-m, 18–22 ft-lb)

Install and tighten the caliper mounting bolt.

TORQUE: 20–25 N·m (2.0–2.5 kg-m, 14–18 ft-lb)

Tighten the pad pin retainer bolt.

TORQUE: 8–13 N·m (0.8–1.3 kg-m, 6–9 ft-lb)

'86–'87, '92–'93 Shown:

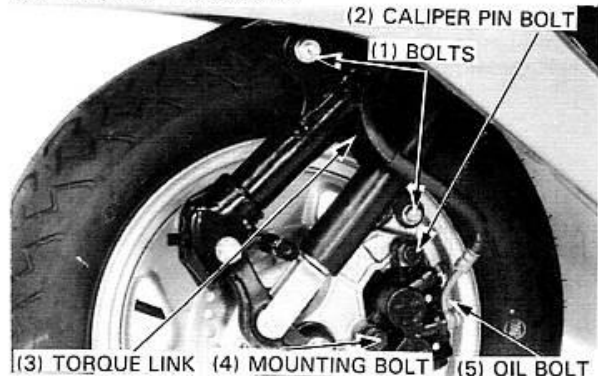

After '93:

Tighten the pad pin.

TORQUE: 15–20 N·m (1.5–2.0 kg-m, 11–14 ft-lb)

Tighten the pad pin plug.

TORQUE: 2–3 N·m (0.2–0.3 kg-m, 1.4–2.2 ft-lb)

Connect the brake hose to the caliper with the oil bolt and two sealing washers.

Tighten the oil bolt.

TORQUE: 25–35 N·m (2.5–3.5 kg-m, 18–25 ft-lb)

Fill and bleed the front hydraulic brake system (page 16-4).

16-15

17. BATTERY/CHARGING SYSTEM

SERVICE INFORMATION	17-1	BATTERY	17-2
TROUBLESHOOTING	17-1	CHARGING SYSTEM	17-3

SERVICE INFORMATION

GENERAL

- Slow charge the battery whenever possible, quick charging should be an emergency procedure only.
- Remove the battery from the scooter for charging.
- The battery on this scooter is a sealed type. Do not try to remove the filler hole caps even during charging. Do not use a non-sealed battery as a replacement.
- All charging system components can be checked on the scooter.
- Inspection should be made in sequence referring to page 23-6 for troubleshooting of the system.

WARNING

- *Do not smoke, and keep flames away from a charging battery. The gas produced by a battery will explode if a flame or spark is brought near.*

CAUTION

- *For battery charging, do not exceed the charging current and time specified on the battery (and shown below). Use of excessive current or charging time may damage the battery.*

- Alternator removal is given in Section 10.

SPECIFICATIONS

ITEM		STANDARD	
Battery	Capacity	12 V—10 AH	
	Voltage at 20°C (68°F)	Fully charged	13.0—13.2 V
		Needs charging	12.3 V
	Charging current	1.2 amperes	
	Charging time	5 Hr	
Regulator/rectifier	Type	Transistorized, non-adjustable	
	Regulate voltage	14.0—15.0 V/5000 rPm	
Charging coil resistance		0.1—1.0 Ω	

TROUBLESHOOTING

No current

- Dead battery
 - battery sulfation
 - Faulty battery
 - Internally shorted battery
 - Charging system failure
- Disconnected battery cable
- Fuse burned out
- Faulty ignition switch

Low current

- Weak battery
- Loose battery connection
- Charging system failure
- Faulty regulator/rectifier

Intermittent current

- Shorted or open battery cable
- Loose charging system connection
- Open or short circuit in lighting system

Charging system failure

- Loose, broken or shorted wire or connection
- Faulty regulator/rectifier
- Faulty alternator

BATTERY/CHARGING SYSTEM

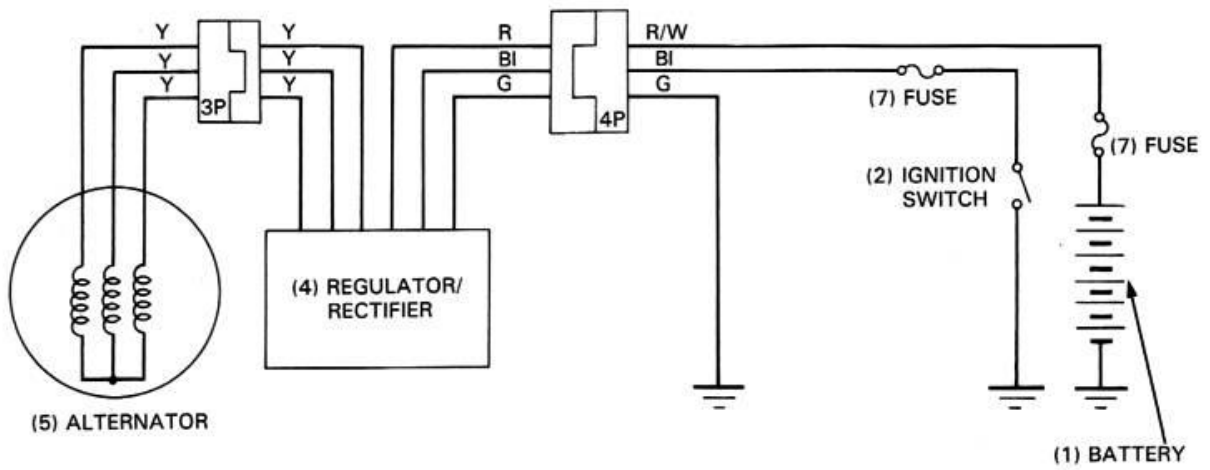
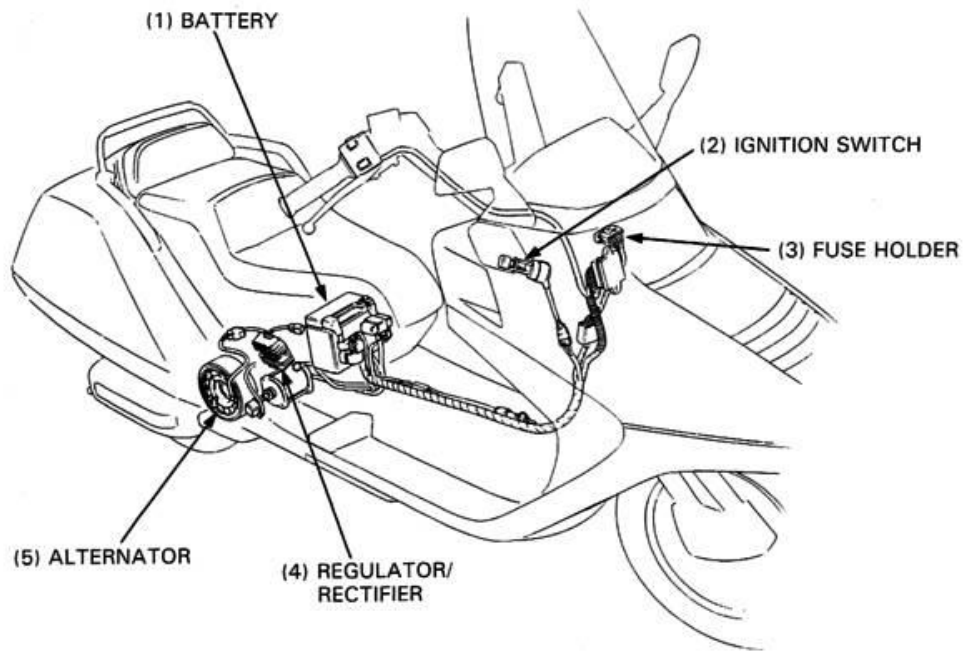

BATTERY/CHARGING SYSTEM

BATTERY

REMOVAL/INSTALLATION

Remove the seat (page 13-2).
Disconnect the battery negative cable first, then the positive cable from the battery.
Remove the battery holder band and remove the battery.
Install the battery in the reverse order of removal.

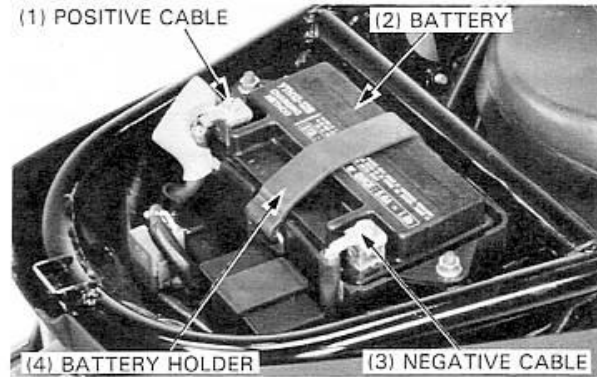

INSPECTION

Voltage

Measure the battery voltage using a digital multimeter.

VOLTAGE: Fully charged 13.0–13.2 V
Under charged Below 12.3 V

TOOL:

Digital multimeter

KS-AHM-32-003
(U.S.A. only)

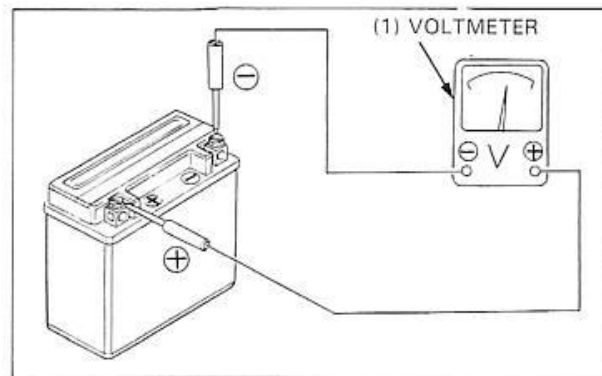

CHARGING

Remove the battery cables and the battery.
Connect the charger positive (+) cable to the battery positive (+) terminal.
Connect the charger negative (-) cable to the battery negative (-) terminal.

Charging current: 1.2 A (standard)
Charging time: 5 hours (standard)

WARNING

- Keep flames and sparks away from a charging battery.
- Turn power ON/OFF at the charger, not at the battery terminals.

CAUTION

- Quick-charging should only be done in an emergency; slow charging is preferred.
- For battery charging, do not exceed the charging current and time specified on the battery. Using excessive current or extending the charging time may damage the battery.

After installing the battery, coat the terminals with clean grease.

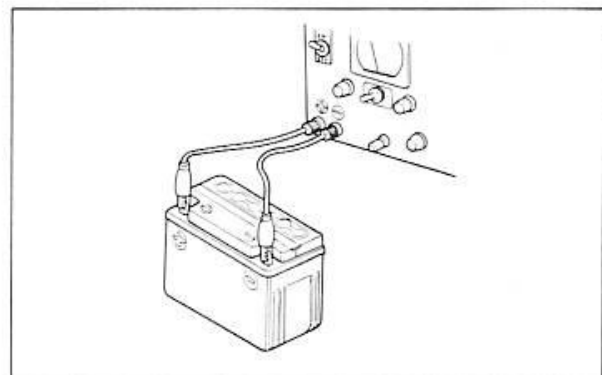

CHARGING SYSTEM

LEAKAGE INSPECTION

Check for battery voltage leakage before making the charging output inspection.

Turn the ignition switch off and disconnect the battery negative cable from the battery.

Connect the voltmeter between the negative cable and the negative battery terminal.

The voltmeter should indicate 0 V with the ignition switch off.

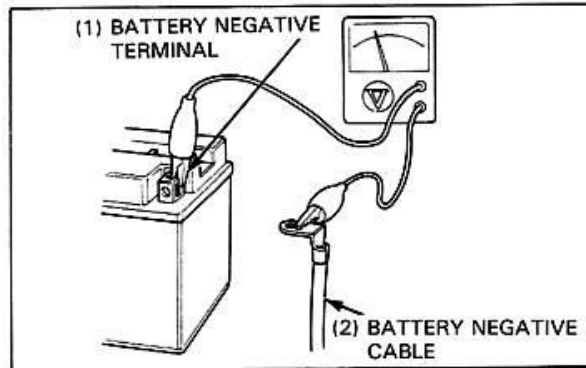

REGULATE INSPECTION

NOTE

- Be sure that the battery is fully charged before performing this test.

Connect the voltmeter across the battery terminals. Start the engine and gradually raise the engine speed and measure the voltage.

NOTE

- Avoid short circuiting to the tester during the test.

VOITAGE: 14.0—15.0 V/5000 rPm

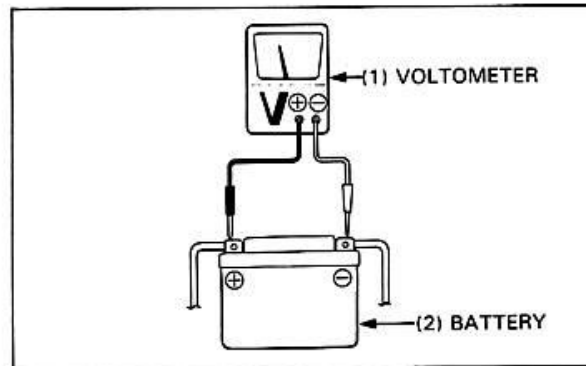

REGULATOR/RECTIFIER INSPECTION

Remove the body center cover (page 13-5). Disconnect the regulator/rectifier wire couplers. Check for continuity between the wire terminals.

ITEM	MEASURE AT:	STANDARD
Battery wire	Red/White—Green	Battery voltage
Charging coil	Between the each yellow	0.1—1.0 Ω
Ignition switch	Black—Green	Battery voltage

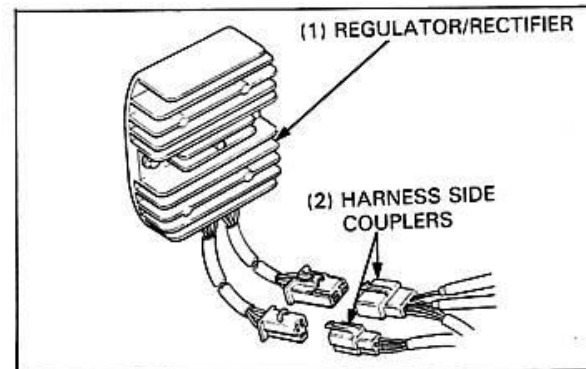

If abnormal, check part of abnormal line.
 If normal, wire harness is faulty.
 Replace the regulator/rectifier if the above item is satisfied.

BATTERY/CHARGING SYSTEM

CHARGING COIL INSPECTION

NOTE

- This test can be made without removing the stator from the engine.

Remove the seat (page 13-2).
Disconnect the alternator 3P coupler.

Measure the resistance between the yellow wire terminals and check for no continuity between each terminal and ground.

RESISTANCE: 0.1—1.0 Ω

Replace the stator if the resistance is out of specification or if there is continuity between the each yellow wire terminal and ground (page 10-3).

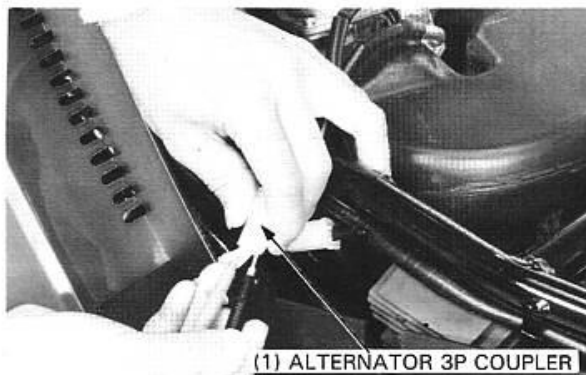

18. IGNITION SYSTEM

SERVICE INFORMATION	18-1	EXCITER COIL	18-2
TROUBLESHOOTING	18-1	IGNITION CONTROL MODULE (ICM)	18-3
IGNITION COIL	18-2	IGNITION PULSE GENERATOR	18-3

SERVICE INFORMATION

GENERAL

- Ignition timing cannot be adjusted since the ignition control module (ICM) is factory preset.
- For spark plug inspection, refer to page 3-5.
- For alternator and ignition pulse generator removal, refer to section 10.
- A continuity check can usually be made without removing the parts from the scooter, simply disconnect the wires and use a continuity tester or ohmmeter at the terminals.
- Inspection should be made in sequence referring to page 23-7 for troubleshooting of the system.

SPECIFICATION

ITEM		STANDARD
Ignition coil	Primary	0.1–0.2 Ω
	Secondary	With plug cap
		Without plug cap
Ignition pulse generator at 20°C (68°F)		50–170 Ω
Exciter coil at 20°C (68°F)		50–350 Ω

TROUBLESHOOTING

No spark at plug

- Poorly connected, broken or shorted wire
 - Between ignition pulse generator and ignition control module (ICM)
 - Between ICM and ignition coil
 - Between ICM and ignition switch
 - Between ignition coil and spark plug
- Faulty:
 - Ignition switch
 - Ignition coil
 - Ignition control module (ICM)
 - Ignition pulse generator
 - Spark plug
 - Side stand switch (After '91)
 - Engine stop switch

Engine starts but runs poorly

- Ignition primary circuit
 - Faulty ignition coil
 - Loose or bare wire
 - Poor connection at ignition switch
- Ignition secondary circuit
 - Faulty ignition coil
 - Faulty spark plug
 - Faulty spark plug wire
 - Poorly insulated plug cap
- Improper ignition timing
 - Faulty ignition pulse generator
 - Stator not installed properly
 - Faulty ignition control module (ICM)

IGNITION SYSTEM

IGNITION COIL

INSPECTION

Remove the trunk cover (page 13-3).
Disconnect the ignition coil primary wires and measure the resistance between the terminals.

RESISTANCE: 0.1—0.2 Ω

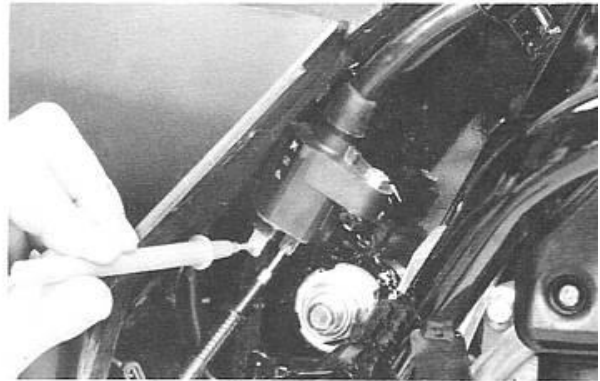

Remove the spark plug cap from the spark plug and measure the resistance between the ignition coil primary wire terminal and the spark plug cap.

RESISTANCE: 7.3—11 k Ω

If the resistance is out of the specification, remove the spark plug cap from the spark plug wire and measure the resistance of the secondary coil.

RESISTANCE: 3.6—4.6 k Ω

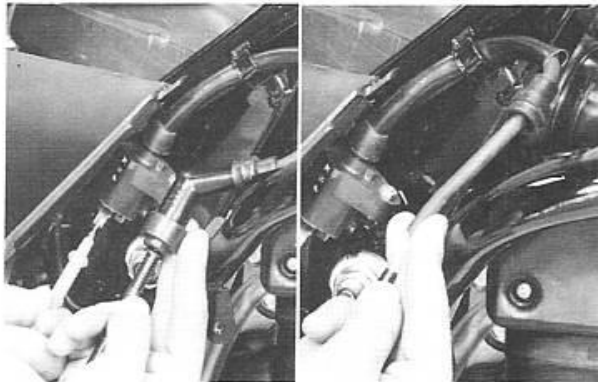

REMOVAL/INSTALLATION

Remove the trunk cover (page 13-3).
Disconnect the ignition coil primary wire connectors and remove the spark plug cap from the spark plug.

Remove the ignition coil mounting bolt and remove the ignition coil.

Install the ignition coil in the reverse order of removal.

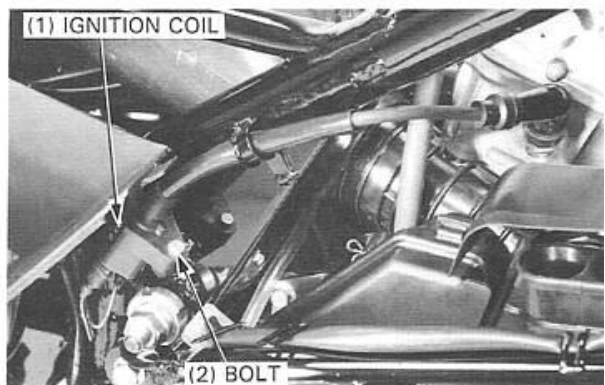

EXCITER COIL

NOTE

- This test can be performed with the stator installed in the engine.

Remove the seat and right rear cover (page 13-2).
Disconnect the stator wire connector.
Measure the resistance between the stator Bl/R wire connector and ground.

RESISTANCE: 50—350 Ω

NOTE

- Measure the resistance in R x 1 Ω range.

Refer to section 10 for stator removal.



IGNITION CONTROL MODULE (ICM)

INSPECTION

Disconnect the ICM couplers and connector and check each circuit according to the table below.

'86-'87:

CIRCUIT	COLOR	CORRECT RESULT	
Ignition switch and engine stop switch	Bl/W-G	There should be no continuity with the ignition switch ON and engine stop switch in the RUN position.	
Exciter coil	Bl/R-G	50-250 Ω	
Ignition pulse generator	G/W-Bu/Y	50-170 Ω	
Ignition coil	Primary	Bl/Y-G	0.1-0.3 Ω
	Secondary	Bl/Y-Plug cap	With the plug cap 7.4-11 kΩ Without the plug cap 3.7-4.5 kΩ

After '91:

CIRCUIT	COLOR	CORRECT RESULT	
Ignition switch and engine stop switch	Bl/W-G	There should be no continuity with the ignition switch ON and engine stop switch in the RUN position.	
Exciter coil	Bl/R-G	50-250 Ω	
Ignition pulse generator	Bu/Y-G	50-170 Ω	
Ignition coil	Primary	Bl/Y-G	0.1-0.3 Ω
	Secondary	Bl/Y-Plug cap	With the plug cap 7.4-11 kΩ Without the plug cap 3.7-4.5 kΩ
Side stand switch	G/W-G	Continuity with the side stand up. No continuity with the side stand down.	

If there is no problem, replace the ICM.

'86-'87:

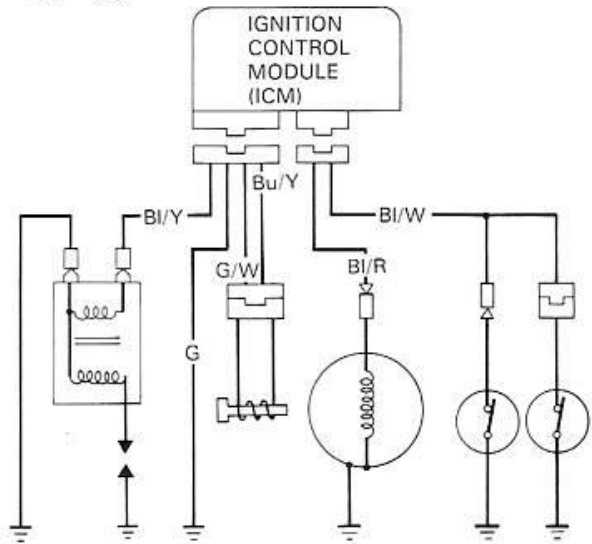

After '91:

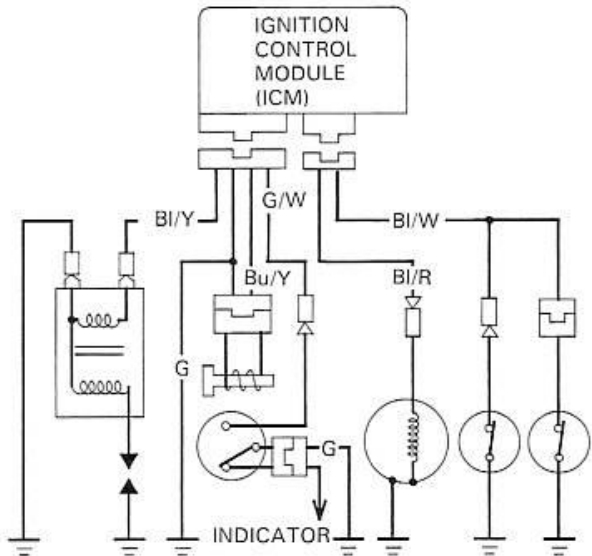

IGNITION PULSE GENERATOR

Remove the right rear cover (page 13-2).
Disconnect the ignition pulse generator wire connectors and measure the resistance between the terminals.

RESISTANCE: 50-170 Ω

For ignition pulse generator replacement, refer to section 10.



19. STARTING SYSTEM

SERVICE INFORMATION	19-1	STARTER RELAY	19-2
TROUBLESHOOTING	19-1	STARTER MOTOR	19-2

SERVICE INFORMATION

GENERAL

Refer to section 10 for starter clutch maintenance.

SPECIFICATIONS

ITEM	STANDARD	SERVICE LIMIT
Starter motor brush length	12.0–12.5 mm (0.47–0.49 in)	6.5 mm (0.26 in)
Starter motor brush spring tension	680–920 g (1.49–2.03 lb)	680 g (1.49 lb)

TROUBLESHOOTING

Starter won't turn

- Burned out fuse
- Weak battery
- Poorly connected, broken or shorted wire
- Faulty:
 - Ignition switch
 - Starter switch
 - Rear brake light switch
 - Starter relay
 - Starter motor
 - Side stand switch (After '91)

Lack of power

- Weak battery
- Loose or bare wire
- Faulty starter gear

Stater turns, but engine does not start

- Faulty starter clutch
- Faulty starter pinion

Wiring Diagrams are in Chapter 21.

Click here to go there -

warning: very large files

STARTING SYSTEM

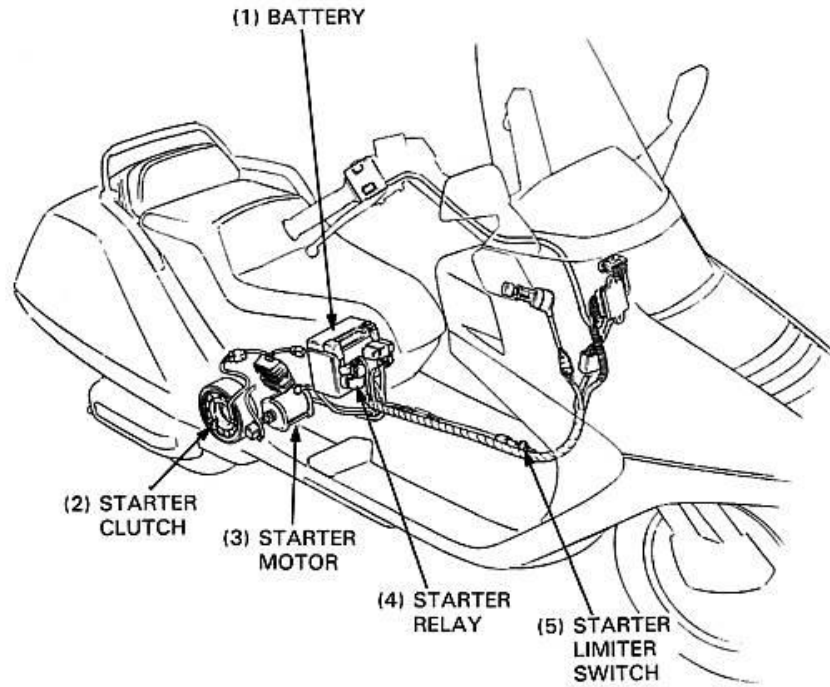

'86-'87:

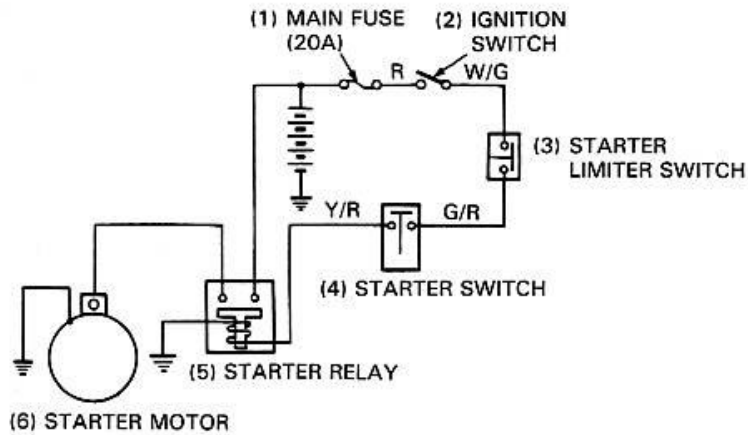

After '91:

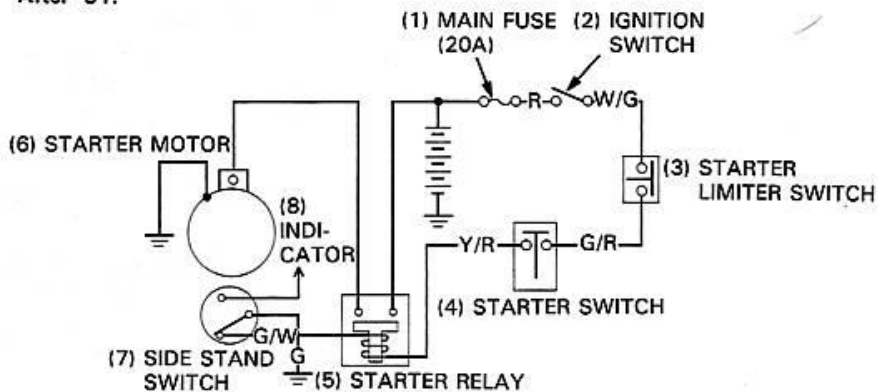

- (9) R: Red
- (10) W: White
- (11) G: Green
- (12) Y: Yellow

20. SWITCHES

SERVICE INFORMATION	20-1	THERMOSTATIC SWITCH	20-8
HEADLIGHT	20-2	TEMPERATURE SENSOR	20-8
INSTRUMENTS	20-2	TEMPERATURE GAUGE	20-9
HANDLEBAR SWITCH	20-5	FUEL PUMP	20-10
IGNITION SWITCH	20-6	FUEL SENSOR	20-10
FRONT TURN SIGNAL	20-6	FUEL GAUGE	20-10
TAIL/BRAKE LIGHT/REAR TURN SIGNAL LIGHT	20-7	SIDE STAND SWITCH	20-11

SERVICE INFORMATION

GENERAL

- Some wires have different colored bands around them near the connector. These are connected to other wires which have the same colored band.
- All plastic plugs have locking tabs that must be released before disconnecting, and must be aligned when reconnecting.
- The following color codes used are indicated throughout this section and on the wiring diagram.

Bu = Blue
Bl = Black
Br = Brown

G = Green
Gr = Grey
Lb = Light Blue

Lg = Light Green
O = Orange
P = Pink

R = Red
W = White
Y = Yellow

- To isolate an electrical failure, check the continuity of the electrical path through the part. A continuity check can usually be made without removing the part from the motorcycle. Simply disconnect the wires and connect a continuity tester or volt-ohmmeter to the terminals or connections.
- A continuity tester is useful when checking to find out whether or not there is an electrical connection between the two points. An ohmmeter is needed to measure the resistance of a circuit, such as when there is a specific coil resistance involved, or when checking for high resistance caused by corroded connections.

Bill's notes:

- 1 - Why the Fuel Pump is here instead of in the "Fuel System" chapter is anyone's guess.
- 2 - Honda's writers have never discovered that all colors (in English) have unique first-last letter combinations (bk=Black, be=Blue, etc.)
- 3 - Don't bother to look for common part numbers for common parts like lamps; Honda will never tell, you have to take a lamp to a parts store and make comparisons -- BUT DO NOTE THE WATTAGE !

SWITCHES

HEADLIGHT

BULB REPLACEMENT

Remove the maintenance cover (page 13-4).
Disconnect the headlight coupler.
Turn the dust seat counterclockwise so that the arrow of the dust seal aligns with the RELEASE mark on the headlight case.
Remove the dust seal.

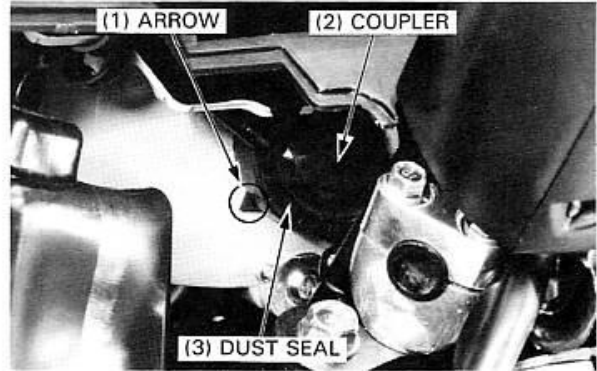

Remove the clip and replace the headlight bulb.

CAUTION

- Do not put finger prints on the headlight bulb, they may create hot spots on the bulb.
- If you touch the bulb with your bare hands, clean it with a cloth moistened with alcohol to prevent its early failure.
- Do not try to replace the bulb with light ON.

Position the dust seal onto the headlight case so that the arrow on the dust seal aligns with the RELEASE mark on the headlight case, then turn the dust seal until the arrow aligns with the LOCK mark.

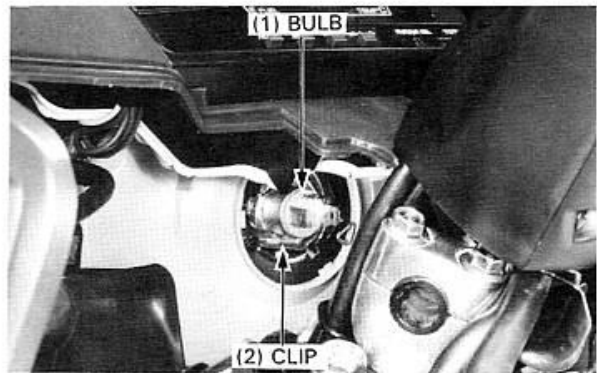

NOTE

- Install the dust seal securely.

REMOVAL/INSTALLATION

Remove the front upper cover (page 13-7).
Disconnect the headlight coupler.
Remove the three headlight mounting bolts and remove the headlight.

Install the headlight in the reverse order of removal.

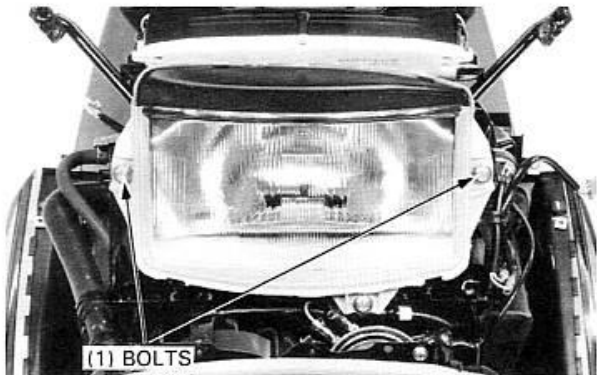

INSTRUMENTS

INDICATOR BULB REPLACEMENT

Remove the maintenance cover (page 13-4).
Pull the bulb socket out and replace the bulb.

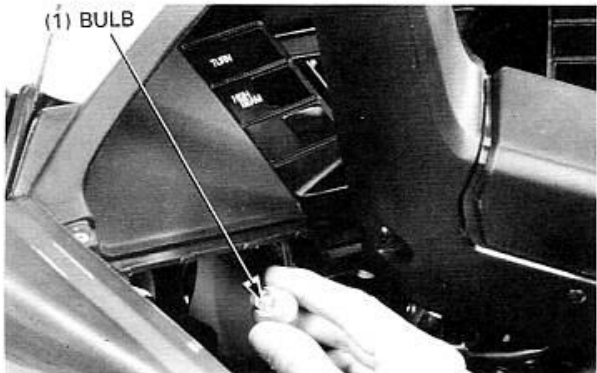

INSTRUMENT BULB REPLACEMENT

Remove the maintenance cover windscreen and instrument panel (section 13).
Pull the bulb socket and replace the bulb.

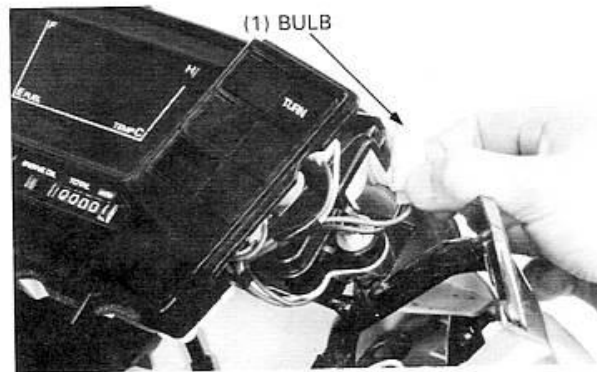
**REMOVAL/INSTALLATION**

Remove the maintenance cover (page 13-4).
Remove the coupler holder cover.



Disconnect the instrument wire coupler and connectors from the coupler holder.



Remove the windscreen and instrument panel (page 13-7).
Disconnect the speedometer cable.
Remove the instrument mounting bolts and instrument.

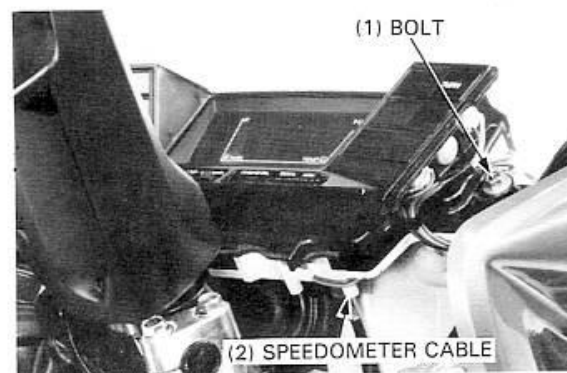

SWITCHES

DISASSEMBLY

Remove the screws and bulbs, and separate the lens from the case.

Remove the coupler cover.

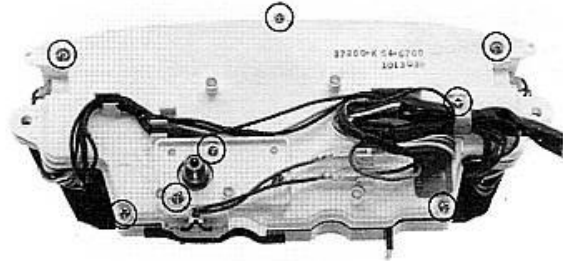

Remove the screws and disconnect the coupler and disassemble the instruments.

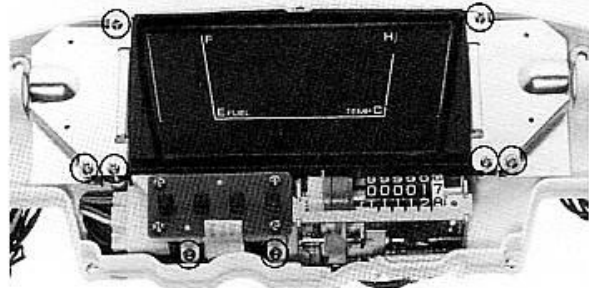

ASSEMBLY/INSTALLATION

Assemble and install the instruments in the reverse order of removal, disassembly.

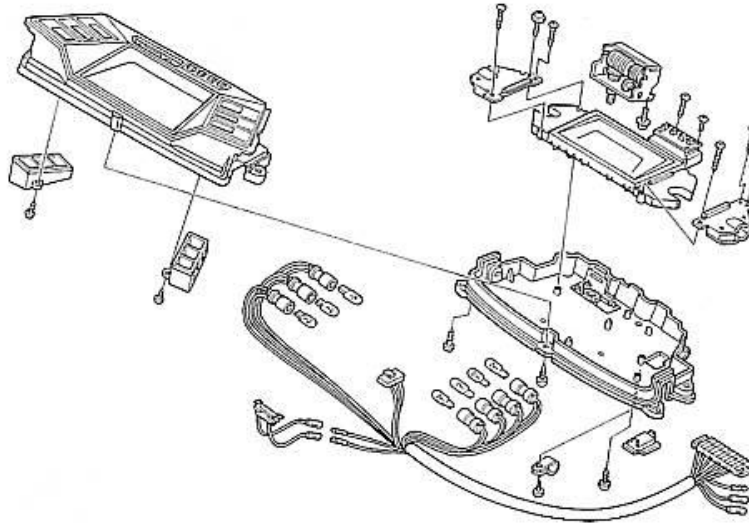

HANDLEBAR SWITCH

The handlebar switch (dimmer, turn signals, horn, starter, engine stop, etc.) must be replaced as an assembly.

Remove the maintenance cover (page 13-4).
 Disconnect the handlebar switch couplers and check for continuity between the coupler terminals for components of the handlebar switch couplers.
 Continuity should exist between the color coded wires in each chart below.

Dimmer Switch

	HL	Hi	Lo
Hi	○—○		
(N)	○—○	○—○	
Lo	○—○		○—○
Color code	W/Bu	Bu	W

Turn Signal Switch

	W	R	L	Po	RPo	LPo
R	○—○			○—○		○—○
Push and N				○—○	○—○	○—○
L	○—○		○—○	○—○		
Color code	Gr	Lb	O	Br/Bu	Lb/W	O/W

Horn Switch

	Ho	BAT ₅
PUSH	○—○	
FREE		
Color code	Lg	Bl/Br

Starter Switch

	HL	BAT ₃	ST ₁	ST ₂
FREE	○—○			
PUSH			○—○	
Color code	W/Bu	Br/Bu	Y/R	G/R

Engine Stop Switch

	IG	E
OFF	○—○	
RUN		
OFF	○—○	
Color Code	Bl/W	G

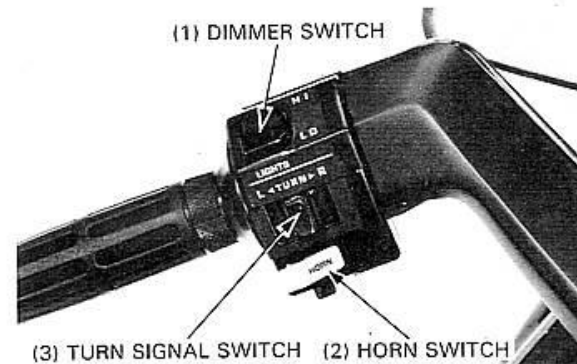
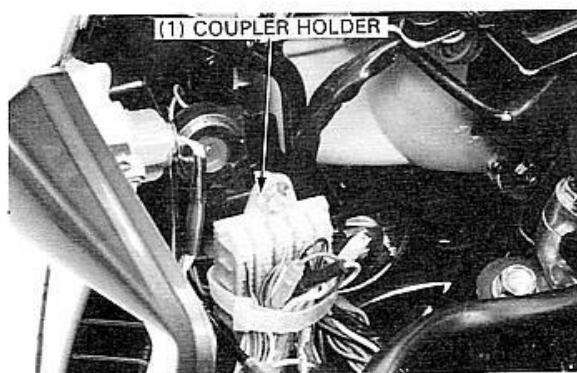

SWITCHES

IGNITION SWITCH

INSPECTION

Remove the maintenance cover (page 13-4).
Disconnect the ignition switch 4P coupler and check for continuity between the terminals.
Continuity should exist between the color coded wires in the chart below.

	BAT ₁	BAT ₂	IG	I
ON	○—○			
OFF			○—○	
LOCK			○—○	
Color	R	B	BI/W	G

REMOVAL/INSTALLATION

Remove the four bolts and ignition switch bracket.
Remove the two screws and ignition switch.
Install the ignition switch in the reverse order of removal.

NOTE

- After installing, make sure that the steering lock operates properly, with no interference to other parts.

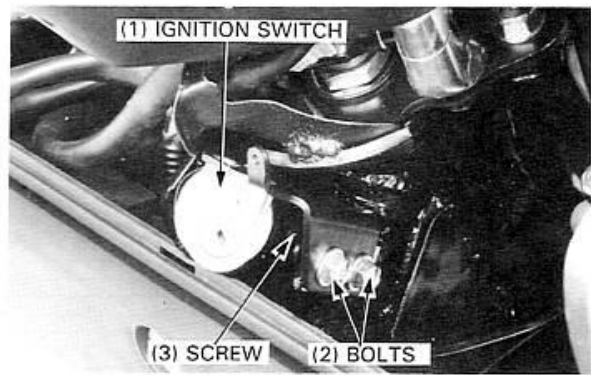

FRONT TURN SIGNAL LIGHT

BULB REPLACEMENT

Remove the maintenance cover (page 13-4).
Remove the bulb socket and replace the bulb with a new one.

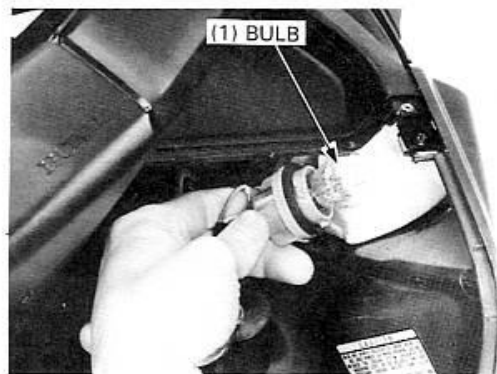

TURN SIGNAL LENS REPLACEMENT

Remove the bulb.
Remove the screws and turn signal lens from the front upper cover.



SWITCHES

THERMOSTATIC SWITCH

The cooling fan motor is actuated by the thermostatic switch located in the right bottom of the radiator.

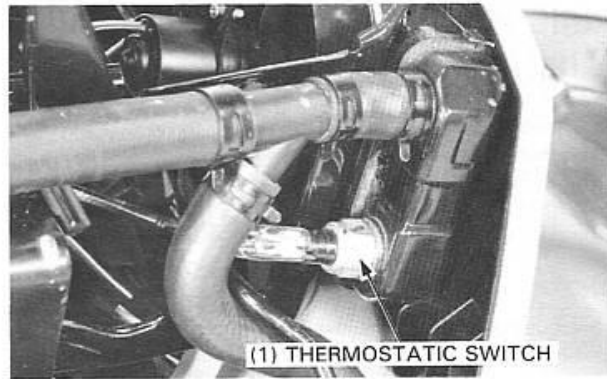

If the cooling fan motor does not start, disconnect the G/BI and G wires from the thermostatic switch and short with a jumper wire.

Turn the ignition switch ON. The cooling fan should start running.

If it does not start, check for battery voltage between G/BI and G wire connectors with the ignition switch ON.

If there is no voltage, check for a blown fuse, loose terminals or connectors, or an open circuit.

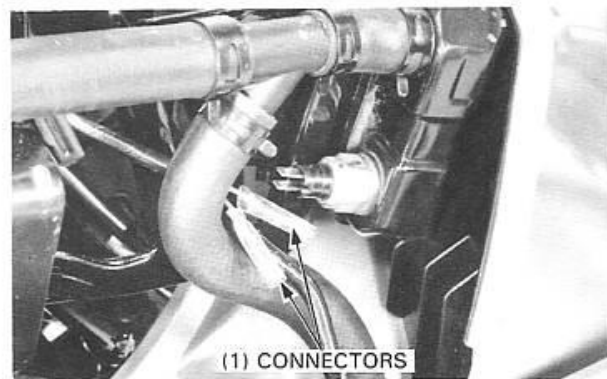

If there is voltage, inspect the thermostatic switch as follows: Connect one lead of an ohmmeter to the connector of the thermostatic switch terminals.

Suspend the thermostatic switch in a pan of coolant (50–50 mixture) and check the temperatures at which the switch opens and closes.

Make sure that there is no continuity at room temperature and then gradually raise the coolant temperature. The switch should show continuity (close) at 93°–97°C (199°–207°F).

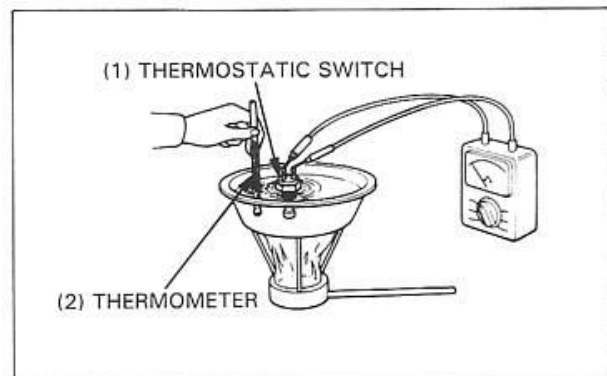

NOTE

- Keep the temperature for 3 minutes to confirm continuity. A sudden change of temperature will cause an error in the temperature reading between the thermometer and switch.
- Do not let the switch or thermometer touch the pan as it will give a false reading.
- Immerse the switch in coolant up to its threads.

TEMPERATURE SENSOR

Remove the seat (page 13-2).

Disconnect the Green/Blue wire from the temperature sensor. Check for continuity between the sensor body and ground.

There should be continuity.

If there is no continuity, check the thermostat housing for looseness and then recheck.

Remove the temperature sensor from the thermostat housing.

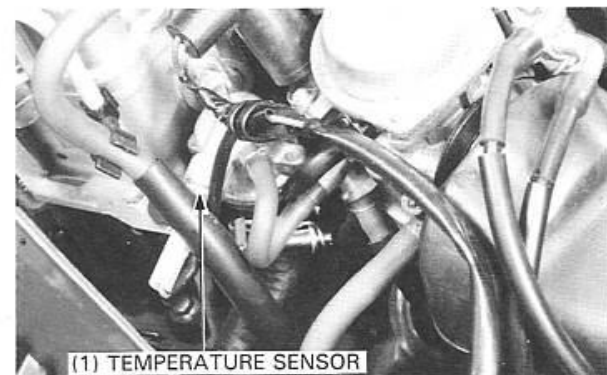

TAIL/BRAKE LIGHT/REAR TURN SIGNAL LIGHT

To replace bulbs:

Remove the two screws and tail garnishes.

Remove the screws and tail/brake light and rear turn signal light lenses.

Install the lenses and garnishes in the reverse order of removal.

NOTE

- Release the tabs of the lens from the slots in the case before removing the lens.

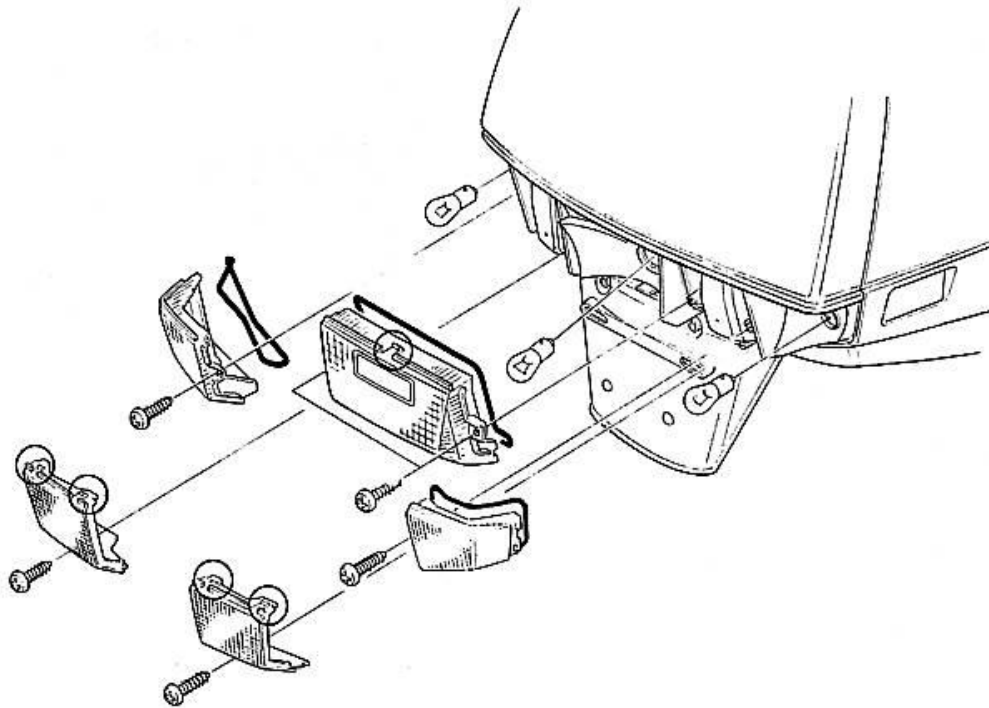

Suspend the temperature sensor in oil over a heater and measure the resistance through the sensor as the oil heats up.

Temperature	50°C (122°F)	80°C (176°F)	100°C (212°F)	120°C (248°F)
Resistance (Ω)	144—179	47.5—57	26—29	14.8—17.2

WARNING

- *Wear gloves and eye protection.*

NOTE

- Oil must be used as the heated liquid to check the function above 100°C (212°F).
- You will get false readings if either the sensor or thermometer touches the pan.

Replace the sensor if it is out of specifications by more than 10% at any temperature listed.

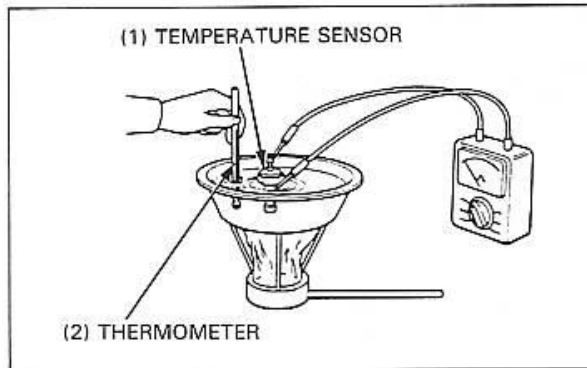

TEMPERATURE GAUGE

Disconnect the wire from the temperature sensor and short it to ground.

Turn the ignition switch to ON.

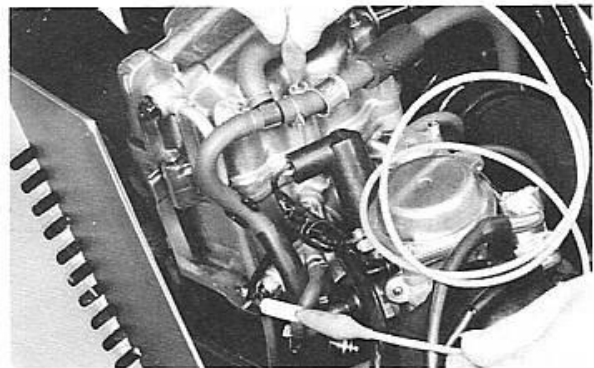

The temperature gauge should display the eighth segment.

CAUTION

- *Do not leave the thermosensor wire grounded for longer than 5 seconds or the temperature gauge will be damaged.*

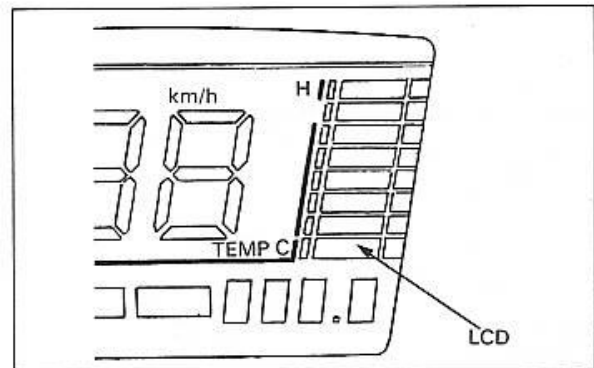

SWITCHES

FUEL PUMP

Remove the seat and body center cover (page 13-5).
Disconnect the fuel pump coupler.

Connect the 12 V positive battery wire to the W/G and BI wire terminals of the pump coupler and negative wire to the G wire terminal.

Disconnect the fuel hose from the carburetor and hold a graduated beaker under the fuel hose.

WARNING

- Do not allow flames or sparks near gasoline.

Turn the ignition switch on and let fuel flow into the beaker for 5 seconds, then turn the ignition switch off.

Multiply the amount in the beaker by 12 to determine the fuel flow capacity per minute.

FUEL FLOW CAPACITY:

450 cc (15,2 US oz, 15,85 Imp oz/minute)

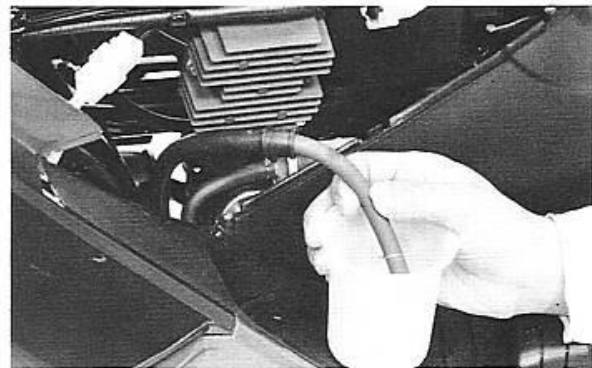
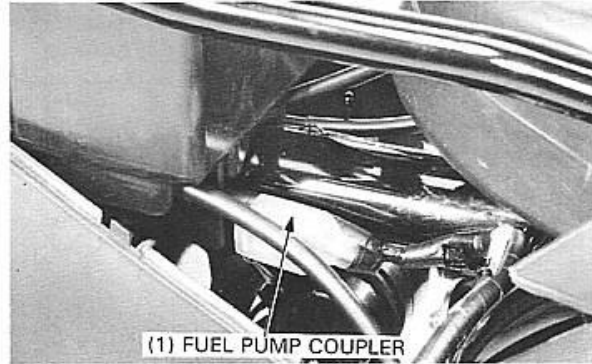

FUEL UNIT

Remove the fuel unit (page 4-14).

Measure the resistance between the coupler terminals by moving the float arm up and down.

Float level		Upper (Full)	Lower (Empty)
RESISTANCE	G/O—Bu/W	566 Ω	33 Ω
	G/O—Y/W	33 Ω	566 Ω
	Y/W—Bu/W	600 Ω	600 Ω

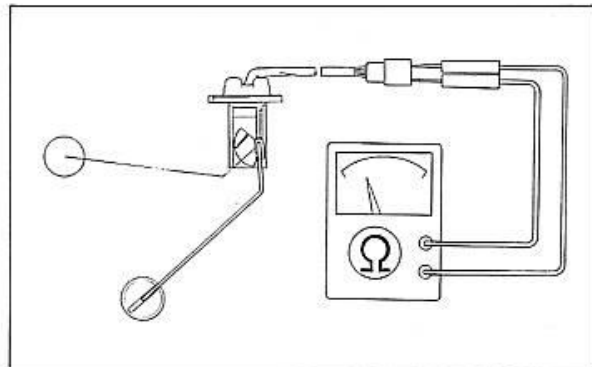

FUEL GAUGE

Remove the fuel unit (page 4-14).

Connect the fuel unit wire coupler and turn the ignition switch ON.

NOTE

- Before performing the following test, operate the turn signals to determine the battery circuit is normal.

Check the fuel gauge segments for correct indication by moving the float up and down.

Float position	Gauge indication
Upper (Full)	All segments ON except first segment
Lower (Empty)	First segment flashing

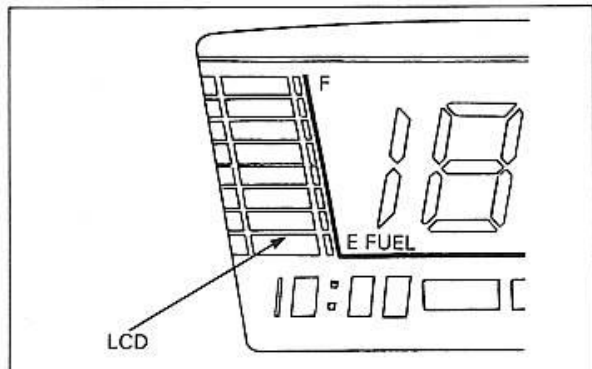

SIDE STAND SWITCH

INSPECTION

Remove the body center cover (page 13-5).
Disconnect the side stand switch 2P connector and the connector.
Check for continuity between each terminal as below.
There should be continuity between the ○—○ marks on the continuity chart.

	Yellow/Black	Green	Green/White
Side stand is up		○—○	○—○
Side stand is down	○—○	○—○	

If the switch is normal, check the related circuit.

If the reading is abnormal, replace the side stand switch with a new one.

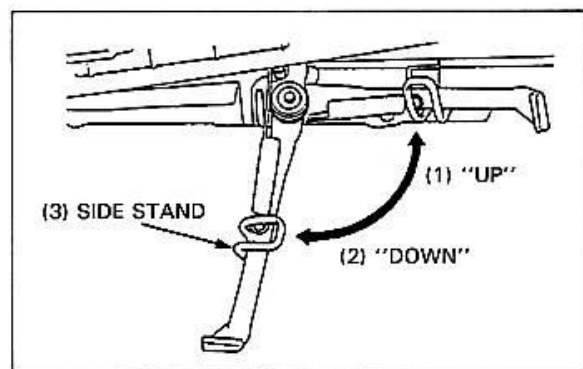
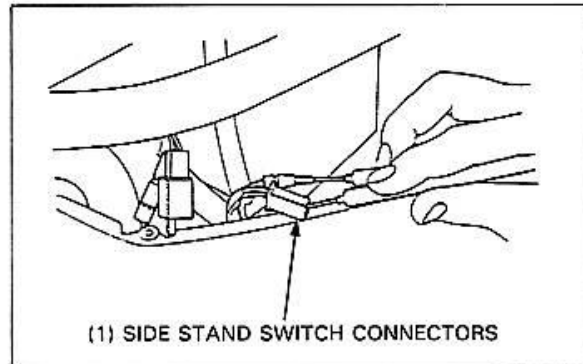

REMOVAL/INSTALLATION

Support the scooter its center stand.
Remove the body center cover (page 13-5).
Remove the left side rail (page 13-5).

Disconnect the side stand switch connectors.
Remove the following:

- return spring
- mounting bolt
- side stand switch

Install the switch in the reverse order of removal.

NOTE

- Align the switch pin with the side stand hole and align the switch groove with the side stand return spring holding pin.

Route the side stand switch wire properly (page 1-14).

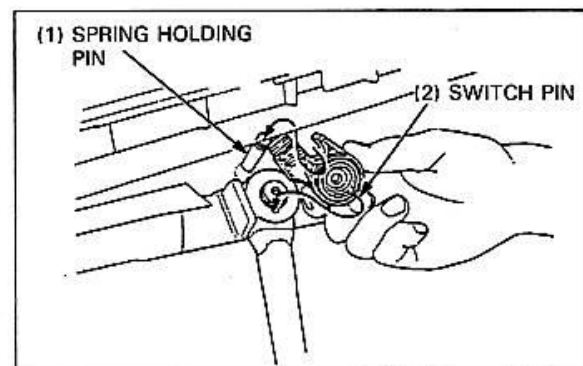
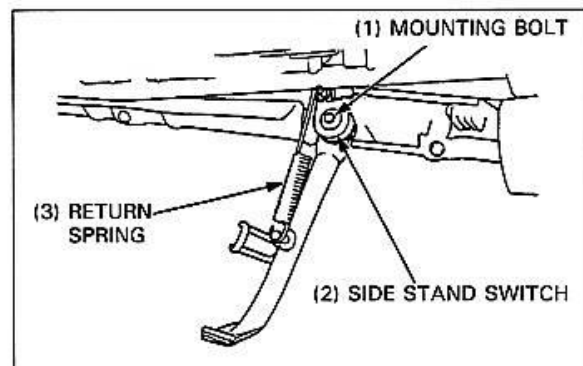

23. TROUBLESHOOTING

ENGINE DOES NOT START OR IS HARD TO START	23-1	CLUTCH, DRIVE AND DRIVEN PULLEYS	23-4
ENGINE LACKS POWER	23-2	HANDLING	23-5
POOR PERFORMANCE AT LOW AND IDLE SPEEDS	23-3	POOR SUSPENSION PERFORMANCE	23-5
POOR PERFORMANCE AT HIGH SPEEDS	23-3	DIGITAL SPEEDOMETER MALFUNCTIONS	23-5
ENGINE NOISE	23-4	UNDER CHARGING/OVER CHARGING OF THE BATTERY	23-6
		NO SPARK AT PLUG	23-7

ENGINE DOES NOT START OR IS HARD TO START

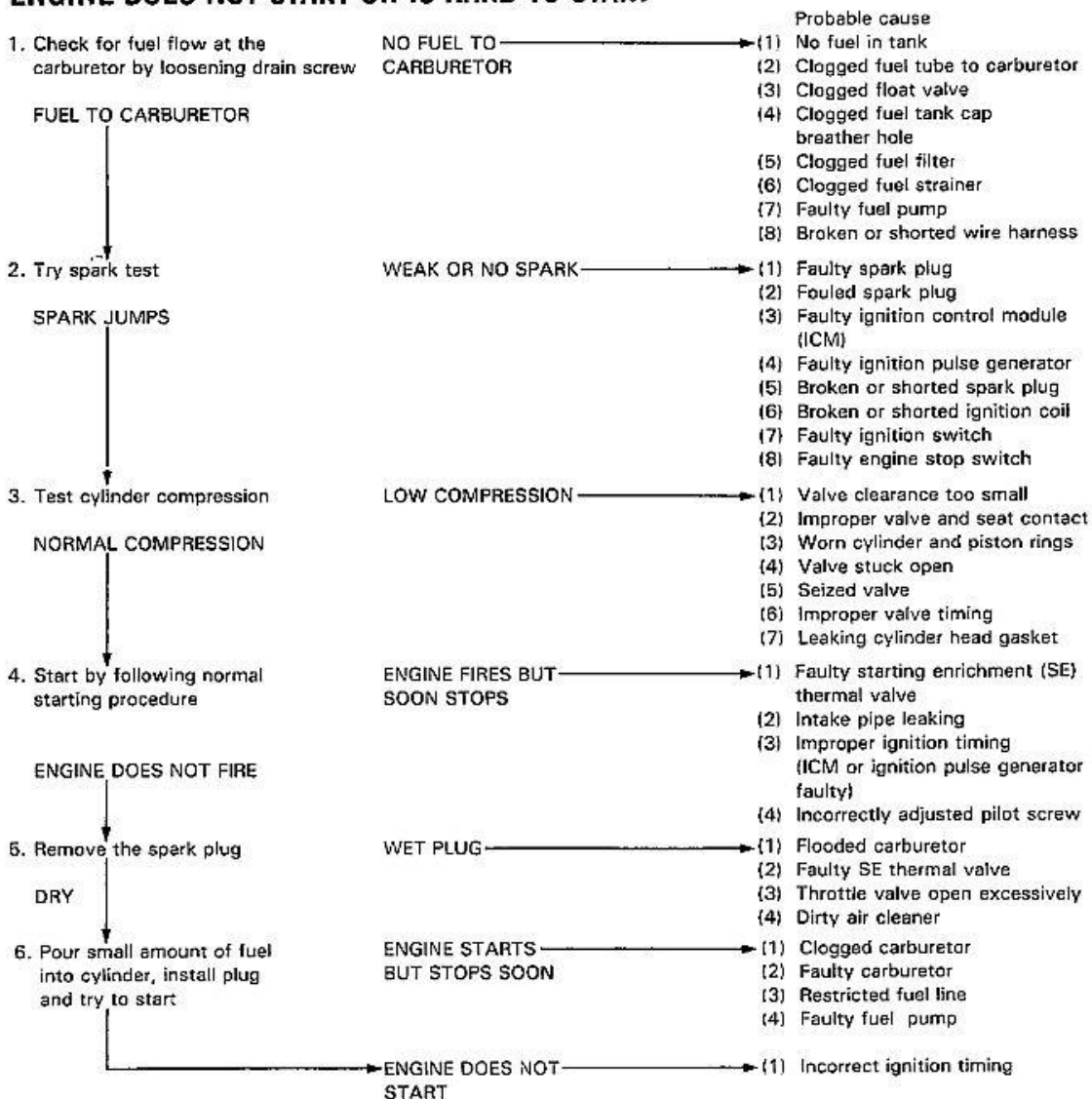

TROUBLESHOOTING

ENGINE LACKS POWER

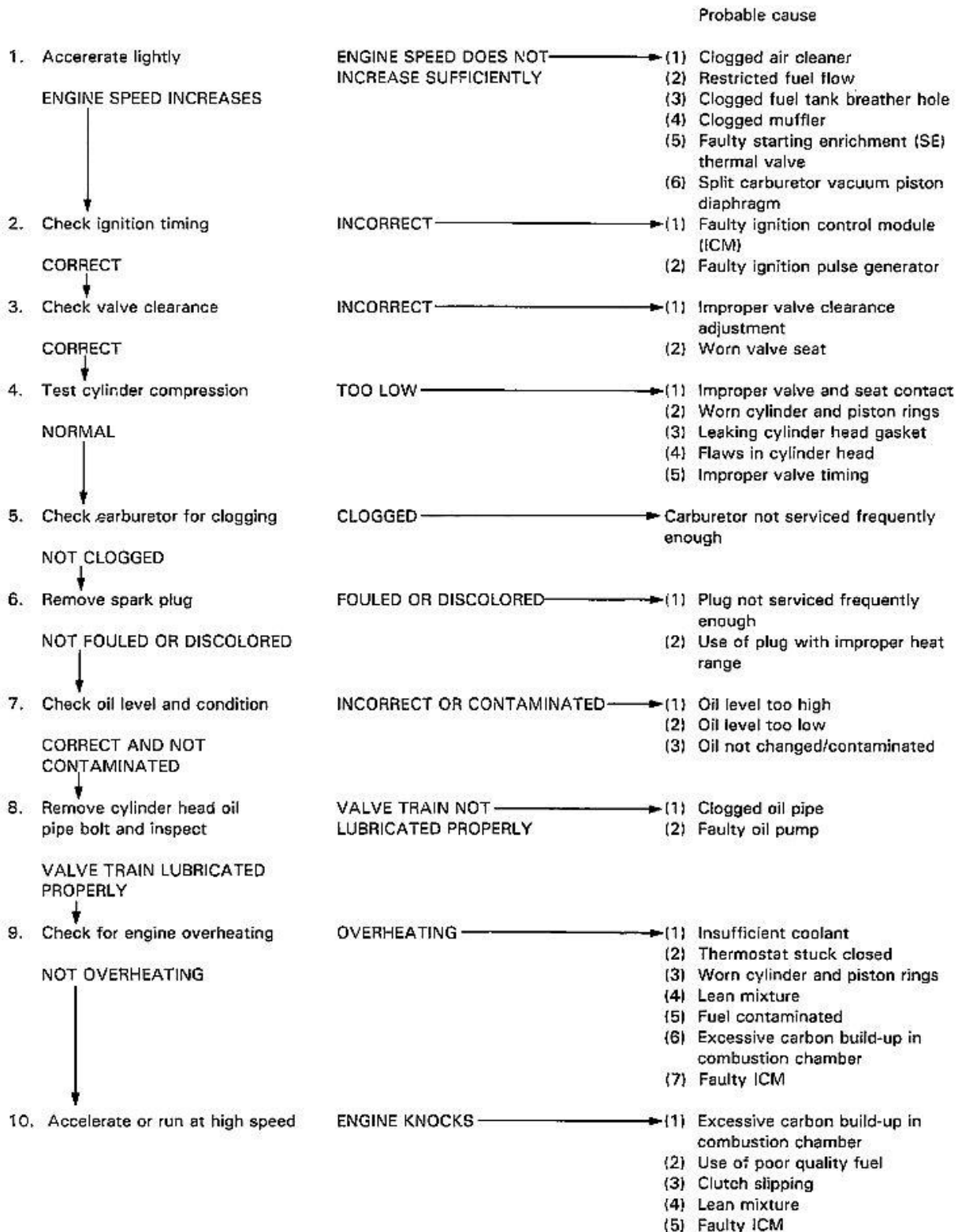

POOR PERFORMANCE AT LOW AND IDLE SPEEDS

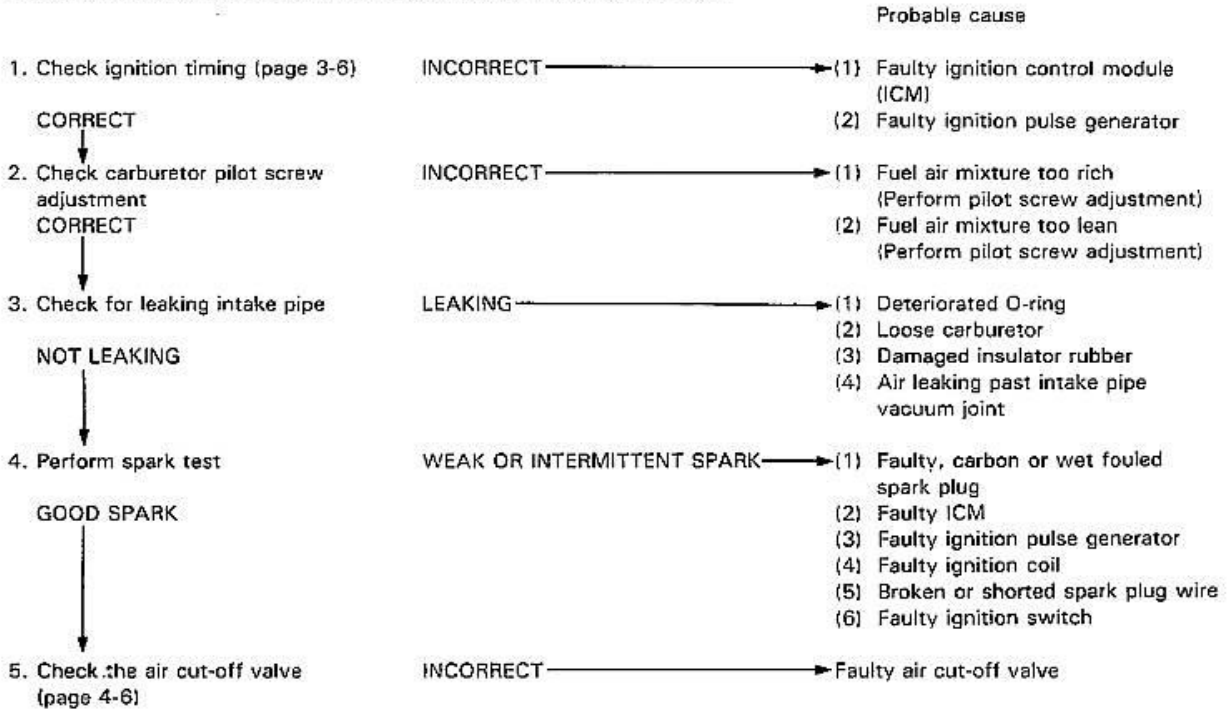

POOR PERFORMANCE AT HIGH SPEEDS

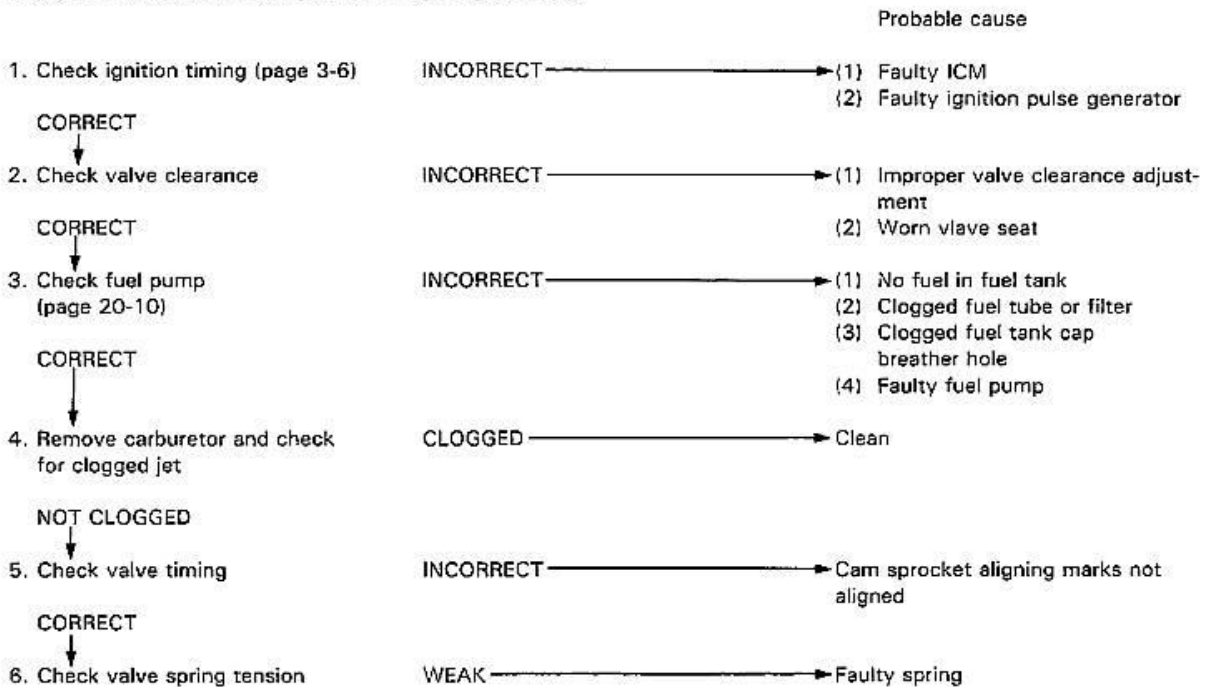

TROUBLESHOOTING

ENGINE NOISE

	Probable cause
1. Valve noise	(1) Valve clearance too large (2) Worn rocker arm and/or camshaft
2. Piston noise	(1) Worn piston and cylinder (2) Worn piston pin and connecting rod small end (3) Excessive carbon build-up in combustion chamber
3. Cam chain noise	(1) Damaged cam chain tensioner (2) Worn cam sprocket teeth (3) Worn or damaged cam chain
4. Crankshaft noise	(1) Worn main journal bearing (2) Worn crank pin bearing
5. Gear noise	(1) Worn or damaged final reduction gears (2) Worn final reduction gear shaft splines

CLUTCH, DRIVE AND DRIVEN PULLEYS

	Probable cause
1. Engine starts, but scooter does not move	(1) Worn or slipping drive belt (2) Broken ramp plate (3) Broken drive face spring (4) Separated clutch lining (5) Damaged driven pulley shaft splines (6) Damaged transmission (7) Seized transmission
2. Scooter creeps or engine starts but soon stops	(1) Broken shoe spring (2) Clutch outer and clutch weight stuck (3) Seized pivot
3. Engine lacks power at start of a grade	(1) Worn or slipping drive belt (2) Worn weight rollers (3) Seized drive pulley bearings (4) Weak driven face spring (5) Worn or seized driven pulley bearings
4. Engine lacks power at high speed	(1) Worn or slipping drive belt (2) Worn weight rollers (3) Worn driven pulley bearings
5. There is abnormal noise or smell while running	(1) Fouled drive belt with oil or grease (2) Worn drive belt (3) Weak driven face spring (4) Worn or seized driven pulley bearings

HANDLING

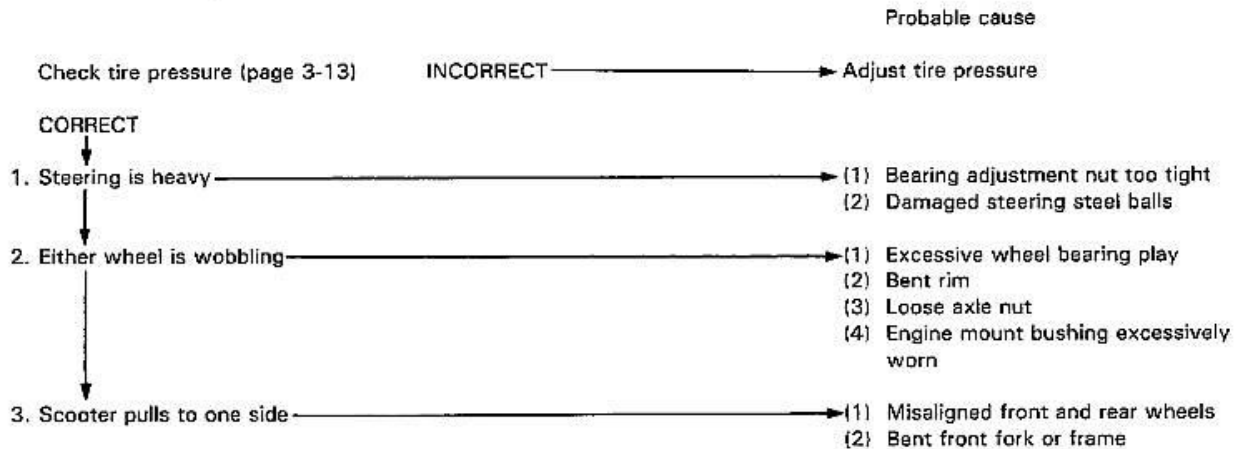

POOR SUSPENSION PERFORMANCE

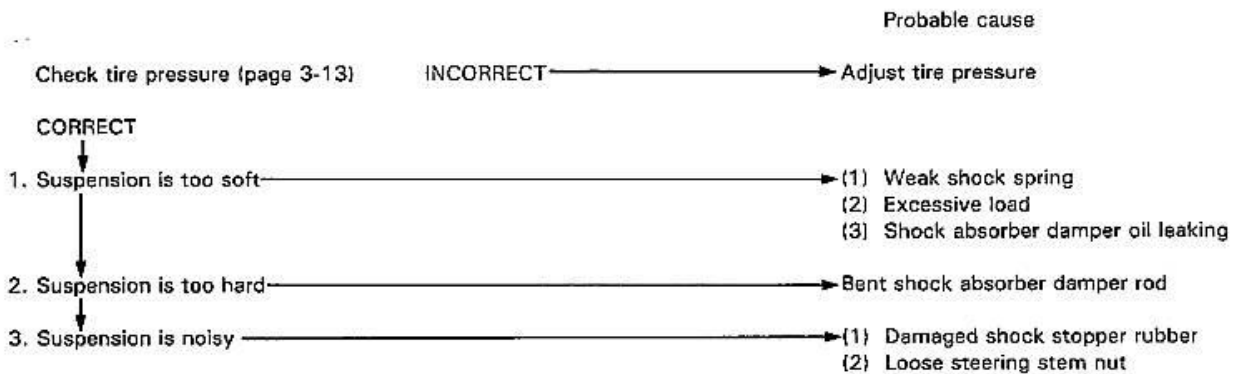

DIGITAL SPEEDOMETER MALFUNCTION

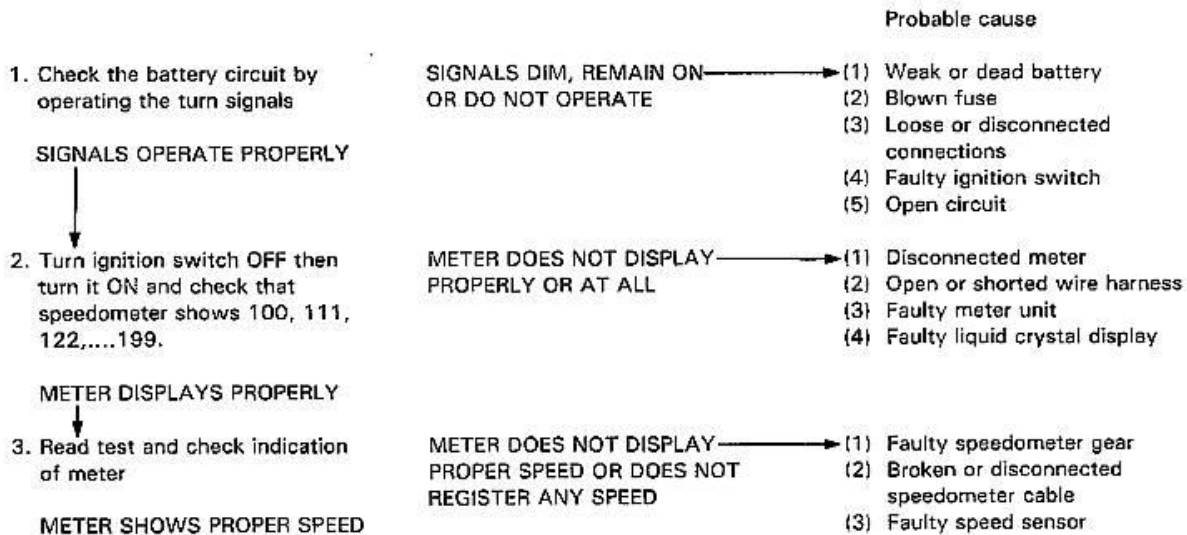

TROUBLESHOOTING

UNDERCHARGING/OVER CHARGING OF THE BATTERY

NOTE: Make sure that the battery is in good condition, use a known-good battery if necessary.

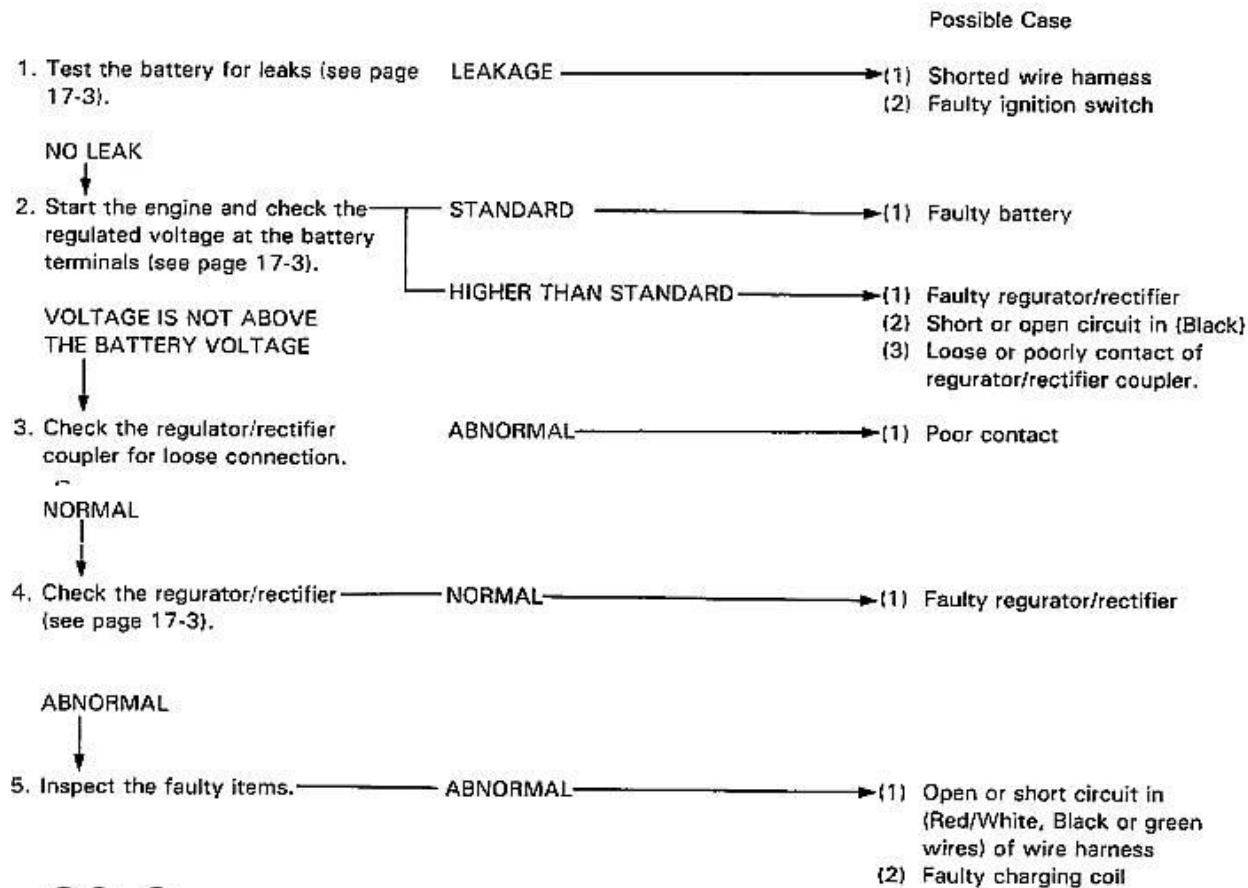

NO SPARK AT PLUG

