

PART NO. INDEX

Part No.	Address No.	Part No.	Address No.	Part No.	Address No.	Part No.	Address No.	Part No.	Address No.	Part No.	Address No.
11000		14515-383-000	C5	16952-028-000	H1	22000		28250-365-000	C13	33101-230-621	G3
11100-383-000	C10	14520-383-000	C5	16953-389-670	H1			28261-107-000	C13	33101-237-600	G2
11191-383-000	C10	14535-107-010	C5	16954-389-670	H1	22100-324-000	C8	28271-107-000	C13	33103-070-000	G4
11200-355-700	C10	14550-383-000	C5	16955-028-004	H1	22121-107-010	C8	28293-124-000	H6	33104-105-000	G4
11330-383-670	C6	14564-383-000	C5	16956-028-004	H1	22201-107-000	C8	28300-365-671	H6	33105-070-000	G4
11341-355-010	C9	14626-383-000	C5	16957-028-000	H1	22311-107-000	C8	28321-355-003	H6	33108-229-003	G4
11361-355-020	C9	14711-107-020	C4	16958-028-000	H1	22350-107-000	C8	28333-124-000	H6	33108-268-000	G2
11393-107-000	C6	14721-324-010	C4	16997-273-000	H1	22361-107-000	C8			33108-324-621	G3
		14751-324-000	C4			22366-383-000	C8			33109-567-003	G4
		14761-324-000	C4	17000		22810-365-000	C6	30000		33120-230-621	G3
		14771-107-020	C4			22816-355-000	C6	30200-329-004	C3	33120-304-611	G2
12000		14775-107-000	G4	17211-383-670	H3	22821-355-000	C6	30200-355-154	C3	33130-229-000	G4
12000-324-680	C2	14776-107-010	G4	17212-385-000	H3	22838-355-000	C10	30201-107-154	C3	33130-237-600	G2
12021-107-310	C2	14781-107-020	C4	17213-383-670	H3	22850-355-000	C8	30201-329-004	C3	33130-286-622	G3
12023-324-310	C2			17217-385-000	H3	22870-355-010	G6	30202-107-004	C3	33140-105-003	G4
12100-383-000	C2	15000		17220-401-680	H3	22878-355-000	H16	30202-107-154	C3	33164-107-600	G2
12191-330-305	C2			17226-382-670	H3			30205-028-004	C3		G3
12209-107-760	C4	15100-383-000	C7	17230-401-680	H3	23000		30205-300-154	C3		G4
12251-331-770	C2	15106-330-000	C7	17241-401-680	H3			30220-329-024	C3	33400-336-730	H11
12261-028-000	C2	15111-365-000	C7	17245-107-010	G5	23121-383-000	C7	30220-355-154	C3	33401-292-003	H11
12271-383-000	C2	15116-107-020	C7			23211-383-000	C13	30250-052-156	H15	33402-268-671	H11
12332-324-000	C3	15126-107-020	C7	17247-240-000	H15	23221-107-000	C13	30370-324-000	C3	33402-336-000	H11
12339-383-000	C3	15131-324-010	C7	17247-303-000	H2	23421-383-000	C13	30372-107-000	C3	33404-268-671	H11
12361-383-000	C10	15136-383-000	C7	17253-401-680	H3	23441-355-000	C13	30500-355-003	H15	33406-268-671	H11
		15331-921-003	C7	17255-028-000	H3	23451-355-000	C13	30530-355-000	H15	33407-284-003	H11
		15332-921-003	C7	17500-355-700ZA	H1	23461-383-000	C13	30600-918-670	H15	33408-341-701	H11
13000		15421-107-000	C10	17510-355-000	H1	23471-383-000	C13	30700-243-610	H15	33443-268-671	H11
13000-355-700	C11	15426-107-000	C10	17520-357-000	H1	23500-383-000	C13	30905-216-000	C4	33450-336-730	H11
13011-383-000	C11	15430-383-000	C7	17611-331-000	H1	23501-355-010	C13			33460-361-003	H11
13021-383-000	C11	15436-107-000	C7	17613-355-620	H1	23501-383-000	C13	31000		33600-304-970	H11
13031-383-000	C11	15441-107-000	C7	17624-355-000	H1	23511-355-000	C13			33600-336-730	H11
13041-383-000	C11	15446-107-000	C7	17910-355-000	G6	23511-383-000	C13	31100-401-680	C9	33602-323-631	H11
13051-383-000	C11	15451-107-000	C7	17914-355-000	G8	23520-383-000	C13	31120-401-680	C9	33604-323-670	H11
13101-355-700	C11	15459-107-000	C7			23530-383-000	C13	31121-355-004	C9	33605-323-670	H11
13102-355-700	C11	15650-383-000	C6	18000		23801-324-000	C13	31530-365-670	H5	33606-074-010	H11
13103-355-700	C11	15761-355-700	C10					31700-124-003	H15	33607-324-670	H11
13104-355-700	C11	15772-292-010	C10	18231-355-000	H5					33610-304-670	H11
13105-355-700	C11	15772-376-000	C10	18233-107-000	H5					33610-304-970	H11
13111-286-000	C11			18284-355-000B	H5	24211-107-000	C15	32000		33615-307-670	H11
13201-383-310	C11	16000		18291-216-000	H5	24221-355-000	C15	32100-401-680	H15	33650-304-970	H11
13310-383-300	C11	16010-116-700	C16	18292-329-000	H5	24231-107-000	C15	32106-041-008	H3	33650-336-730	H11
13321-355-700	C11	16011-143-620	C16	18300-355-620	H5	24241-107-000	C15	32111-365-670	H13	33660-306-670	H12
13381-383-300	C11	16012-355-700	C16	18311-355-620	H5	24271-355-000	C15	32112-041-008	H3	33660-306-670	H12
		16013-116-700	C16	18315-355-620	H5	24301-355-000	C15	32150-401-680	H15	33666-304-650	H12
14000		16014-116-700	C16	18320-355-000	H5	24411-107-000	C15	32173-369-000	H15	33701-098-631	H13
14101-355-700	C4	16015-116-700	C16	18325-355-000	H5	24430-324-000	C15	32906-355-000	H15	33701-331-000	H14
14311-107-000	C11	16016-143-620	C16	18360-355-000	H5	24435-383-000	C15	32907-331-000	H16	33702-313-000	H14
14321-107-010	C5	16022-355-700	C16	18362-720-000	G14	24610-107-760	C15	32976-107-000	C9	33702-323-603	H13
14401-383-003	C5	16100-355-700	C16			24621-107-760	C15	32985-107-780	H10	33703-077-671	H13
14431-384-000	C4	16118-086-004	C16			24631-107-000	C15	32985-355-000	H16	33703-098-003	H14
14451-383-000	C4	16165-355-700	C16			24651-107-000	C15			33708-077-671	H13
14456-383-000	C4	16168-355-700	C16	18365-355-670	H5	24700-313-010	H6	33000		33708-098-000	H14
14500-383-000	C5	16213-355-700	C2	18371-355-710	H5			33100-107-612	G2	33709-074-671	H14
14510-383-000	C5	16229-107-000	C2	18391-313-000	H5	28000		33100-383-621	G3	33709-077-671	H13
		16950-365-671	H1			28211-383-000	C13	33100-401-681	G4	33711-361-000	H14
						28221-107-010	C13	33101-229-000	G4	33719-074-670	H14

PART NO. INDEX

Part No.	Address No.	Part No.	Address No.	Part No.	Address No.	Part No.	Address No.	Part No.	Address No.	Part No.	Address No.
33719-077-671	H10	40544-355-000	G15	44713-331-671	G12	51449-355-003	G11	61105-355-000	G7D	84906-118-000	H13
	H13			44715-355-006	G12	51454-355-013	G11	61114-033-000	G10		H14
33741-340-670	G8	41000		44804-355-003	G12	51500-355-023	G11	61301-391-000B	G2		
33750-355-620	G8			44830-355-620	G5	51521-355-003	G11		G3	87000	
33905-303-003	G2	41201-355-810	G15	44832-355-620	G5				G4		
	G4	41201-382-670	G15			52000		61303-074-000	G2	87128-355-710ZA	H2
34000		41241-307-010	G15	45000					G3	87151-355-730	H16
						52110-355-620ZA	H8		G4	87501-355-620	H16
34901-329-003	G4	42000		45010-355-000	G12	52147-028-300	H8	61303-105-000	G2	87505-355-620	H10
34902-202-000	G5			45131-364-670	G12	52400-355-700	H9		G3	87506-382-670	H16
34902-202-600	G2	42301-401-680	G14	45134-121-000	G12	52401-355-700	H9		G4	87508-120-000	H3
34903-303-003	G4	42304-107-000	G15	45134-250-000	G14	52403-331-003	H9	61311-355-620	G5	87560-375-680B	H1
34905-212-000	H12	42313-074-010	G14	45143-364-670	G13	52405-355-000	H9				
34906-030-013	H14	42601-401-680	G15	45410-364-671	G13	52406-355-000	H9	66000		88000	
34906-098-931	H13	42606-355-000	G15	45411-087-820	G13	52422-455-000	H9				
34908-230-000	G5	42607-355-620	G15	45450-355-000	G6	52430-355-010	H9	66214-538-910	H10	88100-375-770	G6
		42620-107-010	G15	45466-329-000	G8	52482-331-003	H9			88100-401-680	G6
		42701-355-003	G15	45468-351-000	G8	52486-056-000	H9	77000		88110-304-621	G6
35000		42711-329-671	G15	45468-355-000	G8	52486-074-000	H9			88120-304-621	G7
		42711-329-672	G15			52488-331-003	H9	77100-355-620	H2	88120-369-650	G7
35010-382-600	H15	42712-300-003	G15	46000		52489-331-003	H9	77205-286-000	H2	88120-375-770	G7
35100-382-671	H15	42712-340-006	G15			52517-331-003	H9	77209-385-000	H10		
35150-401-681	G6	42713-300-003	G15	46514-355-000	H6			80000		89000	
35200-358-003	G6	42713-340-006	G15	46515-355-000B	H6	53000				89010-355-700	H16
35320-358-003	G6	42715-355-006	G15	46516-355-000	H6			80100-382-670	H10	89214-355-710	H16
35330-401-681	G6					53100-355-620	G8	80102-355-620ZA	H10	89217-355-000	H16
35350-355-601	H6	43000		50000		53141-355-000	G6	80103-382-610	H10	89502-918-000B	H16
35357-083-000	H6			50100-355-620ZA	H16	53143-355-000	G6	80108-061-000	H12		
35750-001-020	C9	43100-401-680	G14	50301-041-305	G8	53144-355-000	G6	80109-340-000	H13	90000	
35752-028-300	C9	43120-365-671	G12	50351-355-000B	H16	53165-116-670	G6		H14		
35753-028-601	C15	43120-365-672	G12	50353-107-000	H16	53166-116-670	G6	80109-382-670	H13	90012-324-000	G4
			G14	50375-331-000	H15	53170-369-700	G6		H14	90031-107-000	C10
37000		43141-400-000	G14	50375-331-000	H15	53171-312-003	G6	80110-312-000	H13	90032-107-000	C10
37200-355-601	G5	43145-401-680	G14	50530-355-620ZA	H6	53172-310-010	G6		H14	90081-107-000	C2
37200-355-611	G5	43151-110-000	G12	50603-033-000	H6	53176-329-000	G6	80202-386-000	H10	90081-355-000	C10
37311-061-810	G5			50618-355-000	H5	53179-329-000	G6	80203-322-610	H10	90081-383-000	C2
37312-051-740	G5	43411-401-680	G14	50617-329-000	H6	53190-369-700	G6			90082-355-000	C9
37314-061-810	G5	43431-385-000	H8	50642-355-000	H6	53192-268-000	G6	83000		90082-383-000	G5
		43434-286-000	G14	50644-329-000	H6	53200-355-620ZA	G8			90083-355-000	C9
		43451-355-620	H6	50660-355-000	H8	53211-028-000	G8	83501-355-620	H16	90100-355-000	H6
38000				50710-382-671	H16	53212-030-000	G8	83540-355-620ZA	H2	90108-283-000	H6
				50721-382-670	H15	53214-001-010	G8	83551-300-000	H2	90114-329-000	G7
38100-382-601	G5	44000				53215-001-000	G8	83618-323-000	H3	90116-283-010	G11
38205-115-000	H2			51000		53220-074-000	G8	83630-355-620ZA	H2	90116-355-000	H5
38300-329-000	H3	44301-110-303	G12	51400-355-025	G11	53231-110-000	G8	83642-355-000	H2	90117-065-000	G8
38300-386-008	H3	44311-229-000	G12	51401-355-000	G11	53600-051-000	H16			90121-355-000	H8
38301-365-670	H3	44601-355-000	G12	51402-355-000	G11	53603-051-000	H16	84000		90122-355-000	H9
38306-292-000	H3	44606-360-000	G12	51403-362-010	G11	53604-098-940	H16			90122-369-000	H13
		44607-360-000	G12	51410-355-013	G11			84701-329-600	H13		H14
		44620-030-000	G12	51412-331-770	G11	61000		84701-382-000	H14		H15
		44701-355-003	G12	51421-355-003	G11			84705-292-000	H15	90127-400-000	G12
		44711-362-003	G12	51425-110-003	G11	61100-355-620ZA	G10	84706-286-000	H15	90128-382-670	G15
40510-355-620ZA	H8	44711-362-006	G12	51432-453-000	G11	61103-357-000	G10	84905-333-000	H13	90133-331-770	H8
40530-355-811	H8	44712-331-671	G12	51437-331-770	G11	61104-357-000	G10			90155-369-000	G8
40530-365-671	H8	44712-340-003	G12	51440-355-003	G11						
40531-355-003	H8	44713-329-003	G12								
40544-355-000	G14										

PART NO. INDEX

Part No.	Address No.	Part No.	Address No.	Part No.	Address No.	Part No.	Address No.	Part No.	Address No.	Part No.	Address No.
90164-028-000	H16	91001-383-008	C11	92000-06025	H15	94001-06000	G7	94111-C8000	G16	96000	
90206-250-000	C4	91002-383-003	C11	92000-06028	H12		H3		H2		
90231-107-000	C7	91002-383-004	C11		H13		H5		H5	96100-60010	C8
90236-300-000	G8	91003-383-003	D12		H14		H6		I1	96100-60060	C14
90304-355-000	G8	91003-383-004	C12	92000-06032	H6		H10	94111-10000	H8	96100-62040	C14
90305-051-000	G13	91004-383-003	C12		H10	94001-08000-0S	G2	94201-16120	H7	96120-62020	C14
90305-401-680	G15	91004-383-004	C12	92000-06035	H13		G3	94201-16150	H7	96140-63010-10	G13
90308-382-670	G15	91201-030-003	C14	92000-08016-0A	G5		G4	94201-20150	C6	96140-63020-10	G16
90321-268-000	G7	91201-030-005	C14	92000-08020-0A	H2		G14		G13	96211-06000	G9
90353-045-000	H8	91202-107-003	G3	92000-08025-0B	G2		H6		G74	96211-08000	C15
90355-369-000	G8	91204-259-003	C6		G3		H8		H8		
90426-355-000	C9	91204-259-005	C6		G4	94001-08000	G13	94201-20250	I1	96220-60100	C15
90441-028-010	C5	91206-286-013	C10	92700-06035	C2		G15	94201-30250	G13		
90442-028-000	C2	91251-121-000	G13	92700-06050	C2		G8		G16	98000	
90443-107-000	C2	91255-331-671	G11			94002-06000	H7	94251-08000	C7		
90451-001-000	C15	91257-230-003	G15	93000		94021-10020-0S	H9	94301-08160	C2	98069-38710	C2
90451-107-000	C13	91257-230-005	G15			94030-08000	I1		C6	98069-58721	C2
90451-365-000	C13	91301-027-000	C6	93500-03006-0A	H1	94101-04000	C3	94301-10140	C10	98200-11000	H2
90451-383-000	C4	91301-107-000	C3	93500-04012-0A	C16		I1	94301-10200	C2		H4
90452-107-000	C13	91301-200-000	C2	93500-04050-0B	H14	94101-05000	G2	94510-12000	C15	98202-66130	H4
90453-107-000	C13	91302-216-000	C9	93500-04050-4J	H13		G3	94510-14000	C15		
90454-107-000	C14	91302-355-000	C9	93500-05006-0G	H5		G4	94520-26000	G11		
90455-107-000	C14	91303-107-000	C2	93500-05008-0A	H12		H5	94601-15000	C12	99000	
90458-107-000	C14		C10	93500-05012-0A	C3		I1	94608-40000	G11	99001-10120	I1
90459-107-000	C14	91304-107-000	G7	93500-05012-1A	G2	94101-05700	H5			99001-14170	I1
90461-107-000	C8	91304-286-000	C2		G3	94101-C6000	C2	95000		99002-13500	I1
90462-107-000	C14	91307-035-000	C6		G4		C8			99003-10000	I1
90481-035-000	C5	91309-035-000	C9	93500-05020-1A	G7		G8	95001-35390-40	C16	99003-20000	I1
90482-028-000	C3	91312-107-000	C9		H16		G10	95001-45100-40	H7	99003-30000	I1
90486-028-000	C3	91335-567-000	C5	93500-05028-0A	G7		H3	95002-02070	C16	99003-50000	I1
90503-051-870	G8			93500-05040-0A	C9		H5	95002-02080	H1	99004-18190	I1
90522-029-000	G10	92000		93500-06012	C9		H8	95002-30000	H3	99005-02000	I1
90524-030-000	G14			93500-06014	G10		H10	95003-08015-10	H4	99007-45000	I1
	H9	92000-05008-4J	H5	93500-06025	C3		H13	95005-11130-30	C10	99008-01600	I1
90525-001-000	H6	92000-05012-0A	H14	93500-06028	G7		H14	95005-11190-30	C10	99101-116-0920	C16
90525-030-000	H10	92000-05020-0A	C7	93500-06032	C9		H15	95011-40000	H7	99103-355-0350	C16
90527-230-000	H9		H13	93500-06040	C6		I1	95012-12000	F4	99500-04007-0A	G3
90528-110-000	G11	92000-06008	G11		H1	94101-C8000	G2	95014-21100	G8		
90543-275-000	G11		H5	93500-06050	C6		G3	95014-61300	H15		
90544-283-000	G11	92000-06010	C5		C10		G4	95014-62100	C7		
90545-323-700	H10		C14	93600-04012-0A	C7		H2		H15		
90581-342-000	H13	92000-06012	G10	93600-06020	C4		H7	95014-62200	H15		
90601-107-000	C14		H8	93600-06028	C7		H8	95014-72401	H7		
90601-354-000	G11		H10	93700-03025-0B	H12		I1	95014-73100	H7		
90605-200-000	G8		H16	93700-05006-0G	H5	94111-C4000	C3	95014-75110	C8		
	C14	92000-06014	C3	93700-05072-0A	C7		C16	95014-92100	C14		
90664-216-000	G15	92000-06020	C5	93700-05020-0B	C3	94111-05000	C9	95015-11100	C9		
90741-003-010	C11		C15	93700-06016	H12		G5	95015-32001	H7		
90755-229-003	G13		G13	93700-06025	H12		H14	95015-42000	H7		
90755-229-005	G13		H6	93901-14010	H16	94111-06000	H10	95015-52000	H7		
90841-001-000	H16	92000-06022	H6				H13	95100-C8032	G9		
		92000-06025	C8	94000		94111-08000	G2	95130-C8045	C9		
			C15				G3	95300-C8070	I1		
91000			C5	94001-05000-0S	C5		G4	95300-C8090	I1		
91001-383-003	C11		C7		H16		G5	95300-C8111	I1		
91001-383-004	C11		H3	94001-06000	C2		G13	95700-C6032	G14		
			H10								

CONTENTS - ENGINE GROUP

CONTENTS

	(Page)
● Contents-Engine group	1
● Contents-Frame group	2
● Instruction for use of parts list	3
● How to use the flat rate time (F.R.T.)...	6
● Model photograph ...	8
● Engine group	9
(address No. G2)	
● Frame group	24
(address No. G2)	
● Part No. Index.....	56

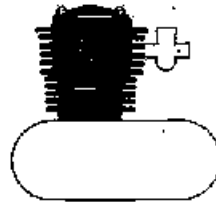

E- 1	Cylinder Head - Cylinder	C 2
E- 2	Contact Breaker - Spark Advancer	C 3
E- 3	Camshaft - Valve	C 4
E- 4	Cam Chain - Tensioner	C 5

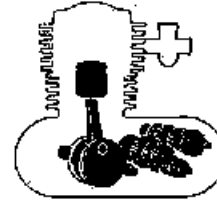

E-10	Crankshaft - Piston	C11
E-11	Transmission - Kick Starter Spindle	C13
E-12	Shift Drum - Spindle	C15

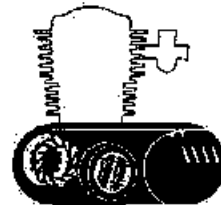

E- 5	Right Crankcase Cover	C 6
E- 6	Oil Pump - Filter Rotor	C 7
E- 7	Clutch	C 8
E- 8	Left Crankcase Cover - Generator	C 9
E- 9	Right & Left Crankcases	C10

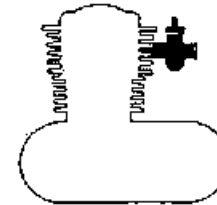

E-13	Carburetor	C16
------	------------------	-----

CONTENTS - FRAME GROUP



F- 1	Head Light (L, ED)	G 2
F- 1-1	Head Light (F)	G 3
F- 1-2	Head Light (U)	G 4
F- 2	Speedometer - Head Light Bracket - Horn	G 5
F- 3	Handle Switch - Lever - Cable	G 7
F- 4	Steering Handle - Top Bridge - Stem	G 9
F- 5	Front Fender	G10
F- 6	Front Fork	G11

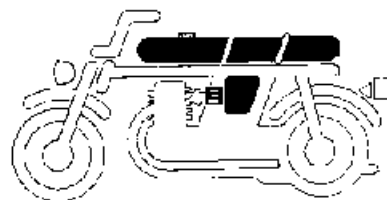

F-10	Fuel Tank	F- 1
F-11	Seat - Side Cover	F- 2
F-12	Air Cleaner - Battery	F- 3

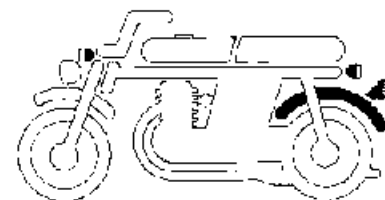

F-17	Rear Fender	H10
F-18	Winker	H11
F-19	Tail Light (L, ED, F)	H13
F-19.1	Tail Light (U)	H14

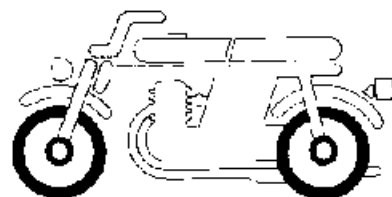

F- 7	Front Wheel - Panel	G12
F- 8	Rear Brake Panel	G14
F- 9	Rear Wheel	G15

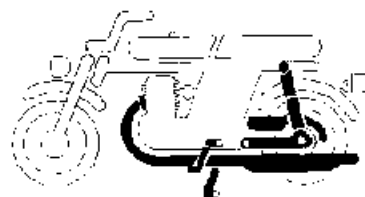

F-13	Exhaust Muffer	H 5
F-14	Pedal - Kick Arm - Stand - Step	H 6
F-15	Rear Fork - Chain Case	H 8
F-16	Rear Cushion	H 9



F-20	Wire harness - Ignition Coil	H15
F-21	Frame Body - Tool	H16

3. Abbreviations

The following abbreviations are used in this parts list.

ASSY. Assembly
 COMP. Complete
 HEX. Hexagonal
 22T 22 teeth

4. Dimensions

All dimensions are given in millimeters (mm) except in the case of steel balls, tires and tire tubes.

Parts	Example	Interpretation
Bolt (Screw)	8 x 12	8mm diameter, 12mm length
Pin	8 x 14	8mm diameter, 14mm length
O-Ring	9.5 x 1.6	9.5mm diameter, 1.6mm thickness
Oil seal	14 x 24 x 5	14mm inside diameter, 24mm outside diameter, 5mm thickness
Tube	5 x 130	5mm inside diameter, 130mm length

5. Superseding of parts

Part numbers given under the part name in the "Description" column indicate that the part number has been superseded by that part number. HONDA may make such superseding without notice.

6. Assemblies

Sections framed with broken lines in the exploded view drawings are available as complete assemblies. (Their individual parts can also be obtained.)

7. Required quantity

The number given in the "Reqd. No." column indicates the quantity of parts used in the section described in that block.

Parts with quantities in () represent optional or oversize parts.

8. Part Modifications Applicable Serial Numbers

In cases where a part has been modified, the serial number of the first vehicle (or frame, engine, carburetor, final drive gear) bearing the modification is listed in the "Serial No." column.

9. Models, Area Codes and Initial Serial No.'s

Models, Area Codes and Initial Serial No.'s given in this parts list can be identified as follows.

Parts with area codes are exclusive for models destined for countries designated.

If no area codes are listed, parts are for common use.

Model-Area Code	Type	Initial Serial Frame No.	Initial Identification Carburetor No.	
TL125S	E	England	TL125S-1003259- <u> </u>	PC04 <u> A </u> -
	F	France	T-125S-1003249- <u> </u>	PC04 <u> A </u> -
	CD	European direct	TL125S-1003239- <u> </u>	PC04 <u> A </u> -
	U	Australia	TL125S-1003269- <u> </u>	PC04 <u> A </u> -

* Of carburetor identification numbers, only the portions underlined in the example below are used for registration.

PC04 A A KC 7

10. Location of stamped serial number

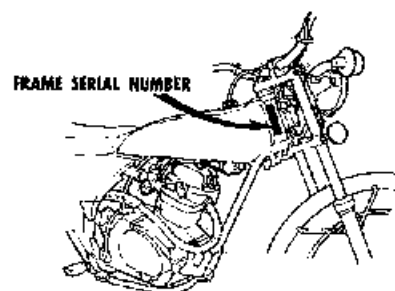

B355-30A

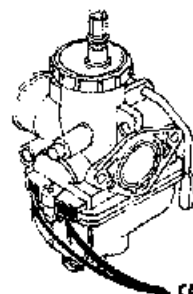

CARBURETOR IDENTIFICATION NUMBER

B065-06

HOW TO USE THE FLAT RATE TIME (F.R.T.)

This F.R.T. (Flat Rate Time) is used to determine the standard labor time allowed for replacement of parts covered by the warranty during the period the warranty is in effect. The F.R.T. for those parts which are not listed herein should be determined from the operation closely related to the replacement of that part.

1. The F.R.T. is based on the following servicing conditions :

- Aliberal allowance is added to the net servicing time.
- Standard times specified are based on the condition that the necessary servicing tools listed in the Service Manual (Motorcycle) which describes the Honda service policy, are available close at hand and the work performed by a mechanic with normal skill.
- Time required for inspection and operational test following the servicing is included in the F.R.T.

2. Method of computing

The job times are listed in tenths of an hour to simplify computation.

(Example) 0.3 18 minutes
5.6 5 hours and 36 minutes

CONVERSION CHART			
Hours	Minutes	Hours	Minutes
0.1	6	0.6	36
0.2	12	0.7	42
0.3	18	0.8	48
0.4	24	0.9	54
0.5	30	1.0	60

3. Computing the F.R.T.

When several jobs are performed at the same time, make the calculation in the following manner.

a. Jobs of non duplicated nature

The F.R.T. for the job is obtained by totalling the F.R.T. for each part replaced

(Example) Replacement of cylinder and clutch spring.

Service Item	F.R.T.
CYLINDER	2.6
CLUTCH SPRING	0.5

The F.R.T. for the job is : $2.6 + 0.5 = 3.1$

b. Jobs of duplicated nature

1. Take the F.R.T. for the last part to be replaced.

(Example) Replacement of piston and cylinder head gasket.

Service Item	F.R.T.
CYLINDER HEAD GASKET	2.5
PISTON	2.8

The F.R.T. for the job is : 2.8

c. Jobs of partially related nature

Total up the F.R.T. for all of the parts replaced and then subtract the F.R.T. for the duplicated operation.

(Example) Replacement of gear shift drum and crankshaft assembly.

Service Item	F.R.T.
GEAR SHIFT DRUM	3.8
CRANKSHAFT	3.9
CRANKCASE DISASSEMBLY	3.6

The F.R.T. for the job is : $(3.8 + 3.9) - 3.6 = 4.1$

Crankcase disassembly is the duplicated operations.

• The F.R.T. shown with (*) includes engine removal and installation

4. Operations other than replacing parts.

a. Removal and installation

No.	Service Item	F.R.T.
1	Engine	1.7
2	Cylinder head	2.5
3	Carburetor	0.4

b. Adjustment, measurement and cleaning of engine.

No.	Service Item	F.R.T.
1	Point-adjustment (including ignition timing adjustment)	0.3
2	Ignition timing-adjustment	0.2
3	Spark plug-adjustment and cleaning	0.1
4	Tappet adjustment	0.2
5	Carburetor idle-adjustment	0.1
6	Engine oil-inspection (excluding oil change)	0.2
7	Clutch-adjustment	0.2
8	Cleaner element-cleaning	0.2
9	Compression-pressure measurement	0.1
10	Battery-checking of electrolyte level and gravity	0.1
11	Carburetor-float level measurement	0.5
12	Oil filter rotor-cleaning	0.4
13	Oil filter screen-cleaning	0.1

Frame

No.	Service Item	F.R.T.
1	Brake-adjustment (front)	0.1
2	Brake-adjustment (rear)	0.1
3	Brake-operation test	0.1
4	Headlight-aimings	0.2
5	Drive chain (includes tension adjustment however, does not include sproket)	0.1

c. Overhaul

1. Overhaul

No.	Service Item	F.R.T.
1	Carburetor	0.7



TL125S-ED



TL125S-U



HONDA

TL125S

www.mustGP.com

1
PARTS LIST

C 2

Block No.

E-1

Cylinder Head - Cylinder

www.CustGP.com

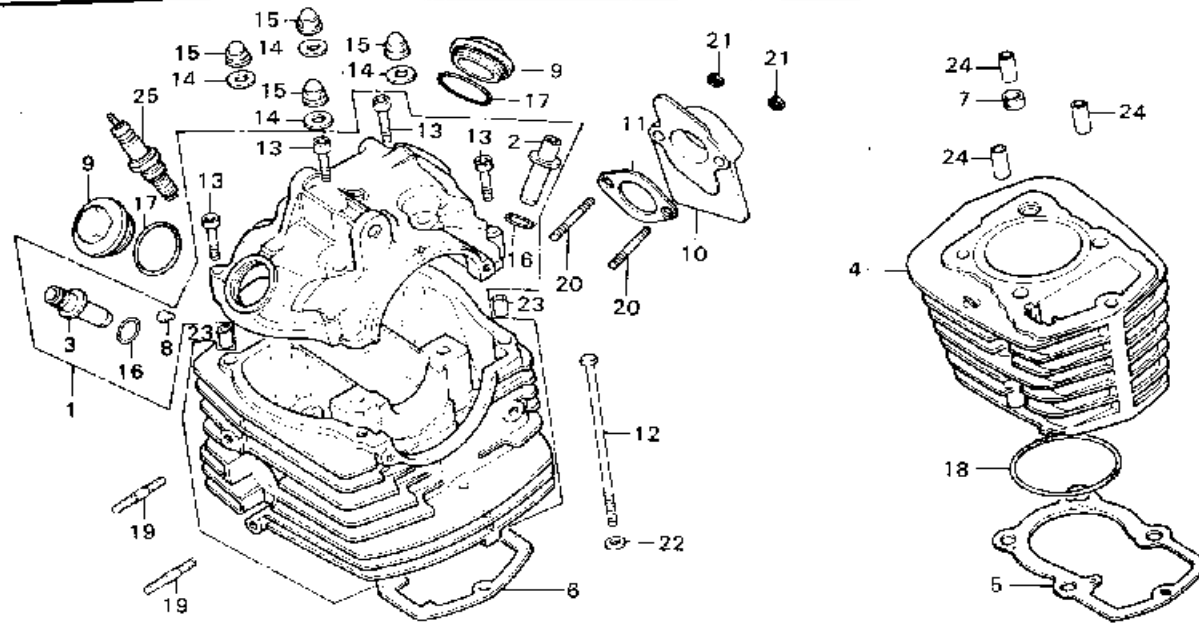

9401

Service Item	F.R.T.	Ref. No.	Part No.	Description	Reqr. No. TL125S	Serial No.	Area Code
CYLINDER HEAD ASSY.	≈3.2	1	12000-324-680	HEAD ASSY., CYLINDER	1		
VALVE GUIDE	≈2.9	2	12021-107-310	GUIDE, INLET VALVE	1		
× Reaming included add 0.2		3	12023-324-310	GUIDE, EXHAUST VALVE	1		
Valve seat refacing excluded		4	12100-383-000	CYLINDER COMP.	1		
If it refaced add more 0.2		5	12191-330-305	GASKET, CYLINDER	1		
CYLINDER COMP.	≈2.6	6	12251-331-770	GASKET, CYLINDER HEAD	1		
• Boring honing excluded		7	12261-028-000	GASKET, CYLINDER STUD	1		
• CYLINDER GASKET		8	12271-383-000	RUBBER, OIL SEAL	1		
CYLINDER HEAD GASKET	≈2.5	9	12361-383-000	CAP, TAPPET ADJUSTING HOLE	2		
and its related parts		10	16213-355-700	INSULATOR, CARBURETOR	1		
CARBURETOR INSULATOR	0.5	11	16229-107-000	GASKET, CARBURETOR INSULATOR	1		
and its related parts		12	90081-107-000	BOLT, HS., 6MM	1		
6 x 36 STUD BOLT	0.3	13	90081-383-000	BOLT, SOCKET, 6MM	4		
• Add 0.1		14	90442-028-000	WASHER, SEALING, 6MM	4		
SPARK PLUG	0.1	15	90443-107-000	NUT, HEX., CAP, 8MM	4		
		16	91301-200-000	O-RING, 1CX1.6	2		
		17	91303-107-000	O-RING, 35X3	2		
		18	91304-286-000	O-RING, 61, 8X2.0	1		
		19	92700-06035	BOLT, STUD, 6X35	2		
		20	92700-06050	BOLT, STUD, 6X50	2		
		21	94001-06000	NUT, HEX., 6MM	2		
		22	94101-06000	WASHER, PLAIN, 6MM	1		
		23	94301-08140	PIN A, DOWEL, 8X14	2		
		24	94301-10200	PIN A, DOWEL, 10X20	3		
		25	98069-38710	PLUG, SPARK (D-8FS-L NGK)	1		
			98069-58721	PLUG, SPARK (X-24ES ND)	1		

1976.01.20

C2

ENGINE GROUP

C 3

Block No.

E-2

**Contact Breaker •
Spark Advancer**

www.CustGP.com

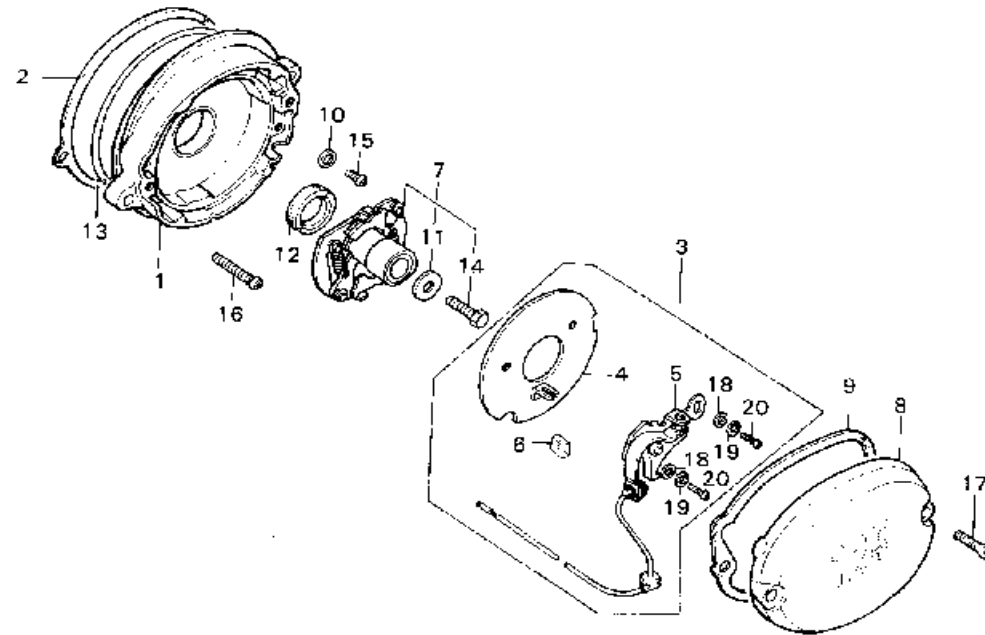

B401-2

Service Item	F.R.T.	Ref. No.	Part No.	Description	Reqd. No. TL125S	Serial No.	Area Code
CONTACT BREAKER BASE/ 15 x 25 x 7 OIL SEAL	0.5	1	12332-324-000	BASE; CONTACT BREAKER	1		
CONTACT BREAKER/BASE PLATE • BASE PACKING	0.1	2	12339-383-000	PACKING; CONTACT BREAKER BASE	1		
CONTACT BREAKER ASSY./ SPARK ADVANCER ASSY.	0.3	3	30200-329-004	BREAKER ASSY.; CONTACT (IND)	1		
CONTACT BREAKER COVER • OIL FELT	0.1	4	30200-355-154	BREAKER ASSY.; CONTACT (TOYO)	1		
			30201-107-154	PLATE; CONTACT BREAKER BASE (TOYO)	1		
			30201-329-004	PLATE; CONTACT BREAKER BASE (IND)	1		
		5	30202-107-004	BREAKER; CONTACT (IND)	1		
			30202-107-154	BREAKER; CONTACT (TOYO)	1		
		6	30205-028-004	FELT; OIL (IND)	1		
			30205-300-154	FELT; OIL (TOYO)	1		
		7	30220-329-024	ADVANCER ASSY.; SPARK (TOYO)	1		
			30220-355-154	ADVANCER ASSY.; SPARK (TOYO)	1		
		8	30370-324-000	COVER; CONTACT BREAKER	1		
		9	30372-107-000	GASKET; CONTACT BREAKER COVER	1		
		10	90482-028-000	WASHER; 5MM	2		
		11	90486-028-000	WASHER; SPARK ADVANCER SETTING	1		
		12	91202-107-003	OIL SEAL; 15X25X7	1		
		13	91301-107-000	O-RING; 75X2.5	1		
		14	9200C-06014	BOLT; HEX.; 6X14	1		
		15	9350C-05012-0A	SCREW; PAN; 5X12	2		
		16	9350C-06025	SCREW; PAN; 6X25	2		
		17	9370C-05020-0B	SCREW; OVAL; 5X20	2		
		18	94101-04000	WASHER; PLAIN; 4MM	2		
		19	94111-04000	WASHER; SPRING; 4MM	2		
		20	99500-04007-0A	SCREW; HOLLOW PAN; 4X7	2		

1976.01.20

C3

C 4

Block No.

E-3

Camshaft • Valve

www.ustGP.com

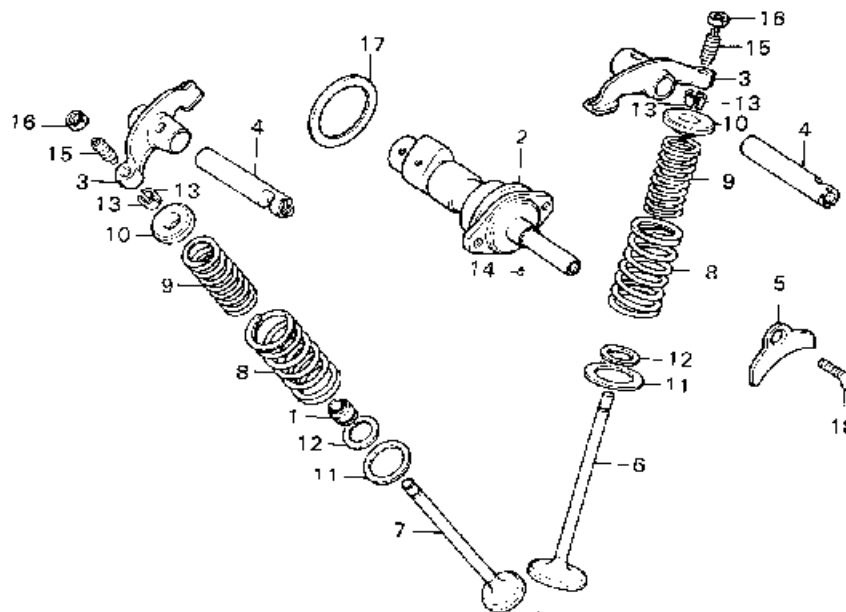

R401-3

Service Item	F.R.T.	Ref. No.	Part No.	Description	Reqd. No. TL125S	Serial No.	Area Code
VALVE	≈2.7	1	12209-107-760	SEAL; VALVE STEM	1		
• Add 0.2 Reaming included		2	14101-355-700	SHAFT; CAP	1		
VALVE SPRING and its related parts	≈2.6	3	14431-384-000	ARM; VALVE ROCKER	2		
• Add 0.1		4	14451-383-000	SHAFT; ROCKER ARM	2		
VALVE ROCKER ARM and its related parts	≈2.4	5	14456-383-000	PLATE; ROCKER ARM SHAFT SET	1		
CAMSHAFT	0.7	6	14711-107-020	VALVE; INLET	1		
		7	14721-324-010	VALVE; EXHAUST	1		
		8	14751-324-000	SPRING; VALVE OUTER	2		
		9	14761-324-000	SPRING; VALVE INNER	2		
		10	14771-107-020	RETAINER; VALVE SPRING	2		
		11	14775-107-000	SEAT; VALVE SPRING OUTER	2		
		12	14776-107-010	SEAT; VALVE SPRING INNER	2		
		13	14781-107-020	SCOTTER; VALVE	4		
		14	50905-216-000	PIN; CAMSHAFT; 3X5.2	1		
		15	90012-324-000	SCREW; TAPPET ADJUSTING	2		
		16	90206-250-000	NUT; TAPPET ADJUSTING	2		
		17	90451-383-000	WASHER; THRUST; 34MM	1		
		18	93600-06020	SCREW; FLAT; 6X20	1		

1976.01.20

C4

C 5

Block No.

E-4

Cam Chain • Tensioner

www.CustGP.com

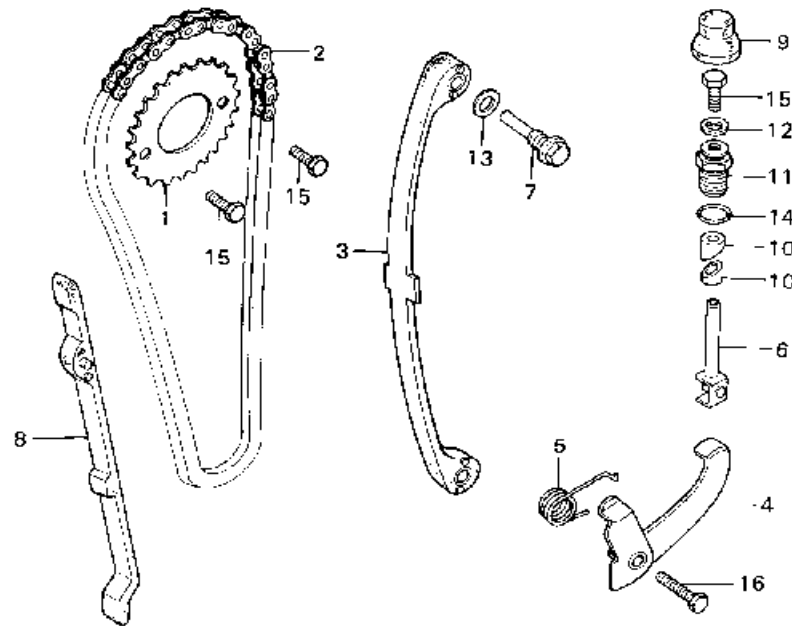

5383 4

Service Item	F.R.T.	Ref. No.	Part No.	Description	Reqd. No. TL125S	Serial No.	Area Code
CAM CHAIN TENSIONER/		1	14321-107-010	SPROCKET, CAM (32T)	1		
TENSIONER SET BAR COMP.	≈2.8	2	14401-383-003	CHAIN, CAM (01025H-98LE)	1		
CAM CHAIN GUIDE	≈2.6	3	14500-383-000	TENSIONER, CAM CHAIN (DAIDO)	1		
CAM CHAIN	1.0	4	14510-383-000	ARM COMP., CAM CHAIN TENSIONER	1		
CAM SPROCKET	0.7	5	14515-383-000	SPRING, CAM CHAIN TENSIONER	1		
CAM CHAIN TENSIONER		6	14520-383-000	BAR COMP., TENSIONER SET	1		
ARM COMP. and its related parts	0.3	7	14535-107-010	BOLT, CAM CHAIN TENSIONER PIVOT	1		
CAM CHAIN TENSIONER PIVOT BOLT	0.1	8	14550-383-000	GUIDE, CAM CHAIN	1		
		9	14564-383-000	CAP, TENSIONER ADJUSTING	1		
		10	14626-383-000	COLLAR, SET BAR LOCK	2		
		11	90082-383-000	BOLT, SPECIAL, 16MM	1		
		12	90441-028-010	WASHER, SEALING, 6MM	1		
		13	90481-035-000	WASHER, 8PH	1		
		14	91335-567-000	O-RING, 13x2.5	1		
		15	92000-06010	BOLT, HEX., 6x10	3		
		16	92000-06020	BOLT, HEX., 6x20	1		

1976.01.20

C5



Block No.

E-5

Right Crankcase Cover

www.ustGP.com

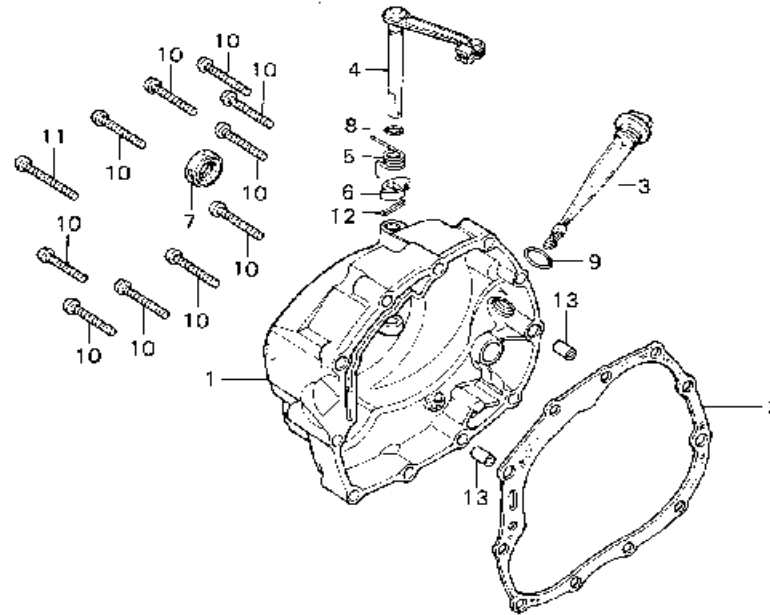

5353- 5

Service Item	F.R.T.	Ref. No.	Part No.	Description	Reqd. No. TL125S	Serial No.	Area Code
R. CRANKCASE COVER COMP.	0.6	1	11330-383-670	COVER COMP., RIGHT CRANKCASE	1		
CLUTCH LEVER COMP. and its related parts	0.5	2	11393-107-000	GASKET, RIGHT CRANKCASE COVER	1		
• 16 x 28 x 7 OIL SEAL		3	15450-383-000	GAUGE, OIL LEVEL	1		
R. CRANKCASE COVER GASKET	0.4	4	22810-365-000	LEVER COMP., CLUTCH	1		
		5	22816-355-000	SPRING, CLUTCH LEVER	1		
		6	22821-355-000	CAM, CLUTCH LIFTER	1		
		7	91204-259-003	OIL SEAL, 16X28X7	1		
			91204-259-005	OIL SEAL, 16X28X7	1		
		8	91301-027-000	O-RING, 6.8X1.9	1		
		9	91307-035-000	O-RING, 18X3	1		
		10	93500-06040	SCREW, PAN, 6X40	10		
		11	93500-06050	SCREW, PAN, 6X50	1		
		12	94201-20150	PIN, SPLIT, 2.0X15	1		
		13	94301-08140	PIN A, DOWEL, 8X14	2		

1976.01.20

C6

C 7

Block No.

E-6

Oil Pump - Filter Rotor

www.ustGP.com

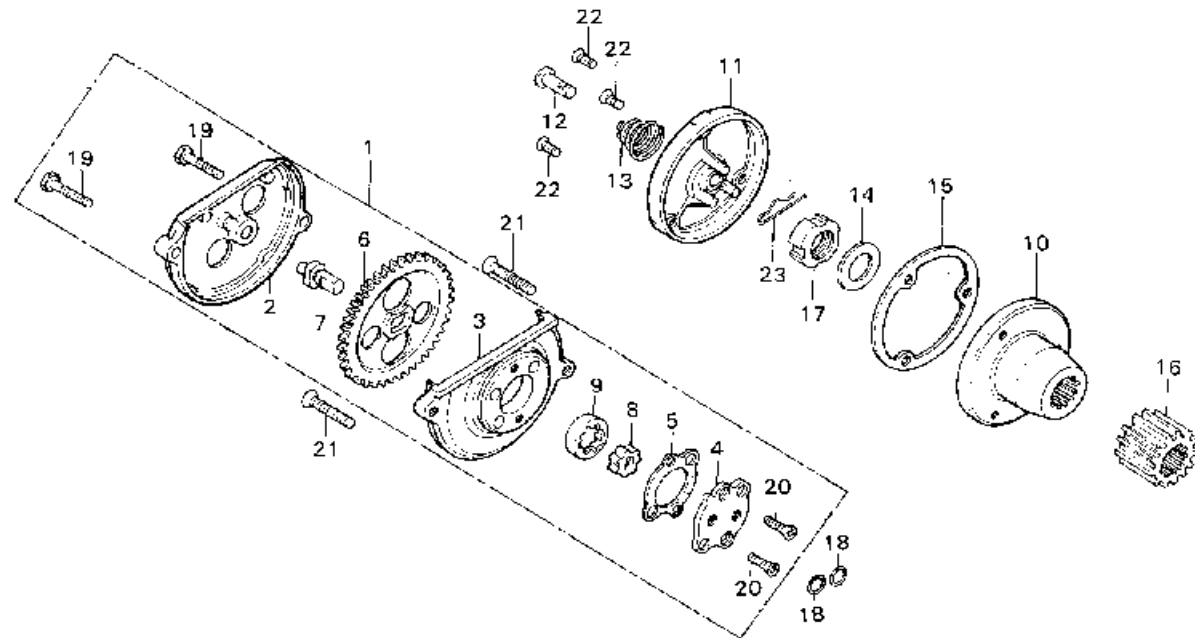

0389- n

Service Item	F.R.T.	Ref. No.	Part No.	Description	Reqd. No. TL126S	Serial No.	Area Code
OIL PUMP ASSY. and its related parts	0.5	1	15100-383-000	PUMP ASSY., OIL	1		
• OIL FILTER ROTOR/DRIVE GEAR		2	15106-330-000	COVER, OIL PUMP GEAR	1		
OIL PUMP GEAR COVER	0.4	3	15111-365-000	BODY, OIL PUMP	1		
• OIL FILTER ROTOR CAP and its related parts		4	15116-107-020	PLATE, OIL PUMP	1		
		5	15126-107-020	GASKET, OIL PUMP	1		
		6	15131-324-010	GEAR, OIL PUMP DRIVE (39T)	1		
		7	15136-383-000	SHAFT, OIL PUMP	1		
		8	15331-921-003	ROTOR, OIL PUMP INNER	1		
		9	15332-921-003	ROTOR, OIL PUMP OUTER	1		
		10	15430-383-000	ROTOR COMP., OIL FILTER	1		
		11	15436-107-000	CAP, OIL FILTER ROTOR	1		
		12	15441-107-000	THROUGH, OIL	1		
		13	15446-107-000	SPRING, OIL THROUGH	1		
		14	15451-107-000	WASHER, OIL FILTER ROTOR LOCK	1		
		15	15459-107-000	GASKET, OIL FILTER ROTOR CAP	1		
		16	23121-383-000	GEAR, PRIMARY DRIVE (11RT)	1		
		17	90231-107-000	NUT, LOCK, 16MM	1		
		18	91304-107-000	O-RING, 9.4X2.4	2		
		19	92000-05020-0A	BOLT, HEX., 5X20	2		
		20	93600-04012-DA	SCREW, FLAT, 4X12	2		
		21	93600-06028	SCREW, FLAT, 5X28	2		
		22	93700-05012-0A	SCREW, OVAL, 5X12	3		
		23	94251-08000	PIN, LOCK, 8MM	1		

1976.01.20

C7



Block No.

E-7

Clutch

www.mustGP.com

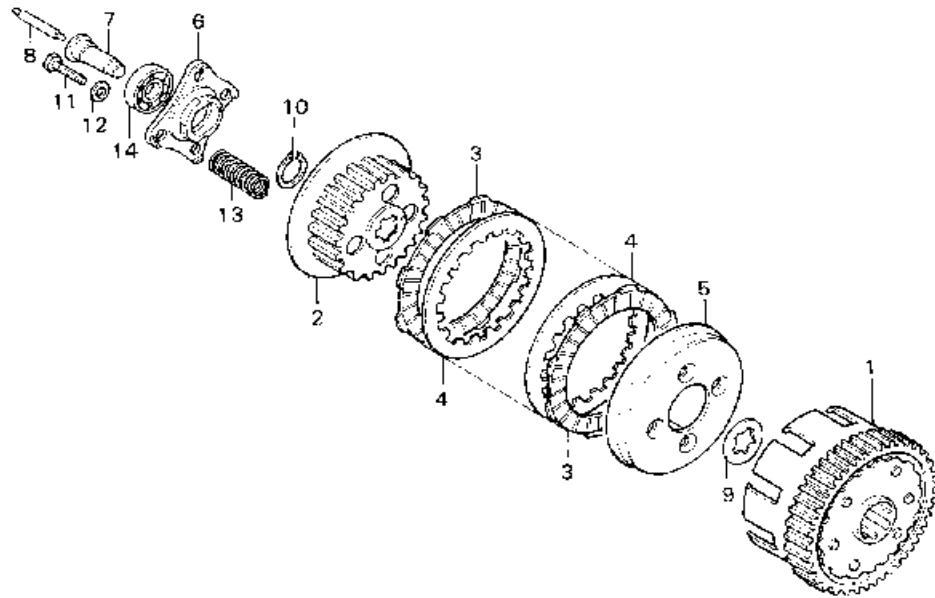

R309 7

Service Item	F.R.T.	Ref. No.	Part No.	Description	Reqd. No. TL125S	Serial No.	Area Code
CLUTCH OUTER/CLUTCH CENTER and those related parts	0.6	1	22100-324-000	OUTER COMP., CLUTCH	1		
• CLUTCH LIFTER PLATE		2	22121-107-010	CENTER, CLUTCH	1		
CLUTCH SPRING	0.5	3	22201-107-000	DISK, CLUTCH FRICTION	5		
CLUTCH LIFTER ROD	0.4	4	22311-107-000	PLATE, CLUTCH	4		
		5	22350-107-000	PLATE, CLUTCH PRESSURE	1		
		6	22361-107-000	PLATE, CLUTCH LIFTER	1		
		7	22366-383-000	PIN, CLUTCH LIFTER GUIDE	1		
		8	22850-355-000	ROD, CLUTCH LIFTER	1		
		9	90461-107-000	WASHER B, SPLINE, 20 MM	1		
		10	90605-200-000	SET RING, 20MM	1		
		11	92000-06025	BOLT, HEX., 6X25	2		
		12	94101-06000	WASHER, PLAIN, 6MM	4		
		13	95014-75110	SPRING 11, CLUTCH	4		
		14	96100-60010	BEARING, BALL, 6001	1		

1976.01.20

C8



Block No.

E-8

**Left Crankcase Cover -
Generator**

www.ustGP.com

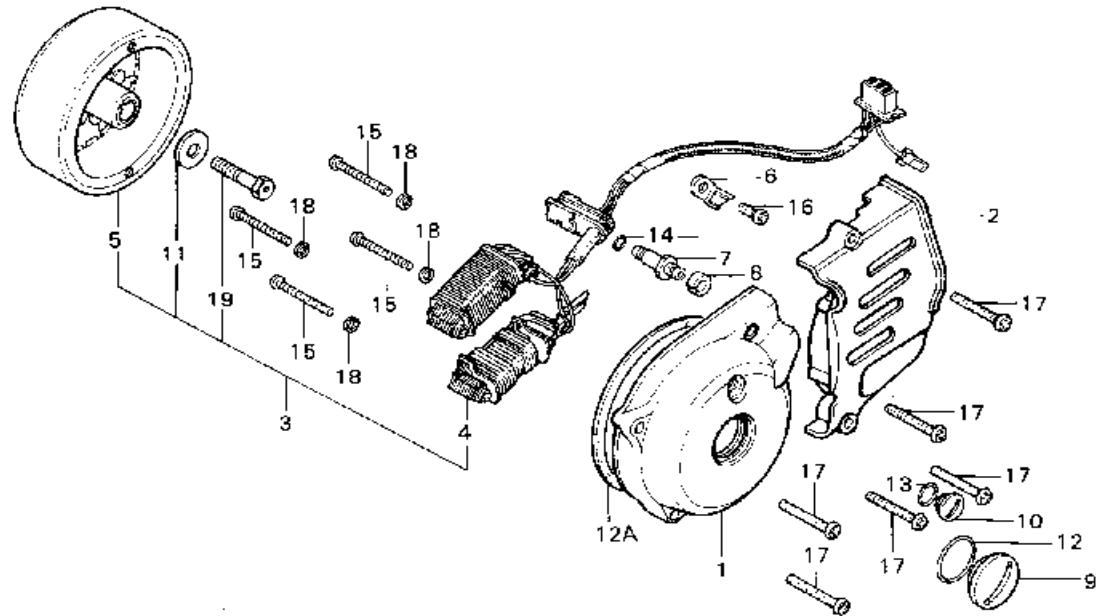

3/85-29

Service Item	F.R.T.	Ref. No.	Part No.	Description	Reqd. No. TL1255	Serial No.	Area Code
A.C. GENERATOR ASSY.	0.3	1	11341-355-010	COVER COMP., LEFT CRANKCASE	1		
• STATOR COMP.		2	11361-355-020	COVER, LEFT CRANKCASE REAR	1		
A.C. GENERATOR ROTOR COMP.	0.2	3	31100-401-680	GENERATOR, FLY WHEEL A.C.	1		
• L. CRANKCASE COVER COMP.		4	31120-401-680	STATOR COMP.	1		
L. REAR CRANKCASE COVER	0.1	5	31121-355-004	FLYWHEEL COMP. (ND)	1		
A.C. GENERATOR CAP		6	32976-107-000	CLAMPER, WIRE HARNESS	1		
• NEUTRAL SWITCH CONTACT ASSY.		7	35750-001-020	CONTACT ASSY., NEUTRAL SWITCH	1		
		8	35752-028-300	SPEACER, NEUTRAL SWITCH	1		
		9	90082-355-000	CAP A, A.C. GENERATOR	1		
		10	90083-355-000	CAP B, A.C. GENERATOR	1		
		11	90426-355-000	WASHER, ROTOR SETTING	1		
		12	91302-216-000	O-RING, 35.5X3	1		
		12A	91302-365-000	GASKET, LEFT CRANKCASE COVER	1		
		13	91309-035-000	O-RING, 11X2.5	1		
		14	91312-107-000	O-RING, 7X1.7	1		
		15	93500-05040-0A	SCREW, PAN, 5X40	4		
		16	93500-06012	SCREW, PAN, 6X12	1		
		17	93500-06032	SCREW, PAN, 6X32	6		
		18	94111-05000	WASHER, SPRING, 5MM	4		
		19	95015-11100	BOLT A1, ROTOR	1		

1976.01.20

C9

C 10

Block No.

E-9

Right & Left Crankcases

www.mustGP.com

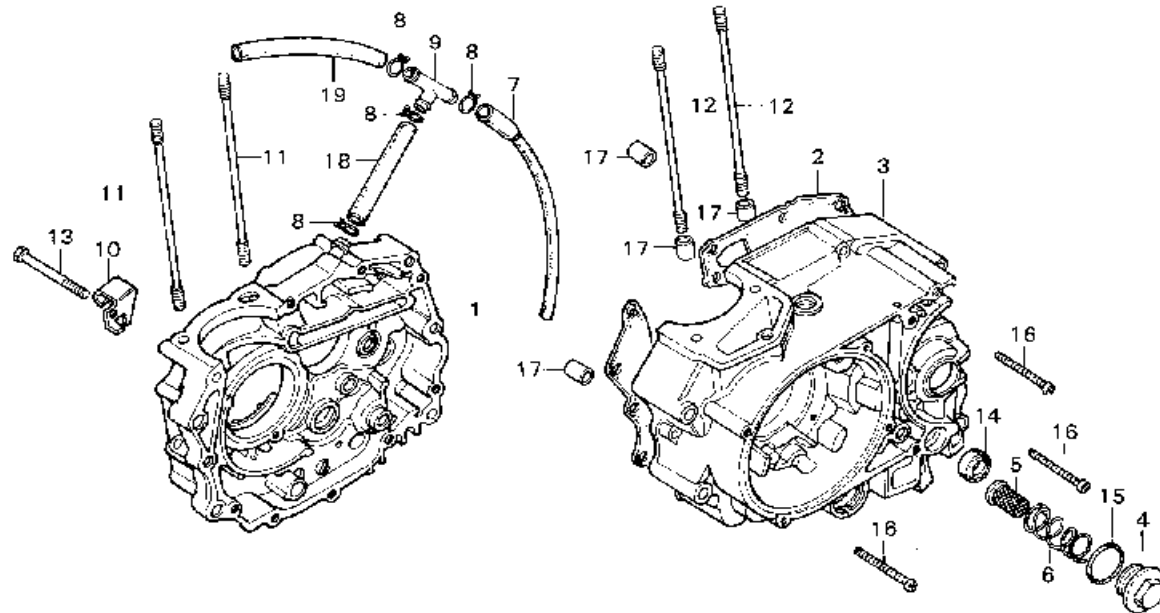

R401-5

Service Item	F.R.T.	Ref. No.	Part No.	Description	Reqd. No. TL125S	Serial No.	Area Code
L. CRANKCASE COMP.	*4.5	1	11100-383-000	CRANKCASE COMP., RIGHT	1		
R. CRANKCASE COMP.	*3.9	2	11191-383-000	GASKET, CRANKCASE	1		
CRANKCASE GASKET	*3.6	3	11200-355-700	CRANKCASE COMP., LEFT	1		
CYLINDER STUD BOLT	*2.7	4	12361-383-000	GAP, TAPPET ADJUSTING HOLE	1		
+ Add 0.1		5	15421-107-000	SCREEN, OIL FILTER	1		
14 x 28 x 7 OIL SEAL	1.0	6	15426-107-000	SPRING, OIL FILTER SCREEN	1		
OIL FILTER SCREEN and its related parts	0.1	7	15761-355-700	TUBE, BREATHER	1		
• CLUTCH WIRE HOLDER		8	15772-292-010	CLIP, BREATHER TUBE	4		
• BREATHER TUBE		9	15772-376-000	JOINT, BREATHER 3-WAY	1		
		10	22838-355-000	HOLDER, CLUTCH WIRE	1		
		11	90031-107-000	BOLT A, CYLINDER STUD	2		
		12	90032-107-000	BOLT B, CYLINDER STUD	2		
		13	90081-355-000	BOLT, HS., 6X55	1		
		14	91206-286-013	OIL SEAL, 14X28X7	1		
		15	91303-107-000	O-RING, 35X3	1		
		16	93500-06050	SCREW, PAN, 6X50	10		
		17	94301-10140	PIN A, DOWEL, 10X14	4		
		18	95005-11130-30	TUBE, 11X130	1		
		19	95005-11190-30	TUBE, 11X190	1		

1976.01.20

C10

C 11

Block No.

E-10

Crankshaft - Piston

www.CustGP.com

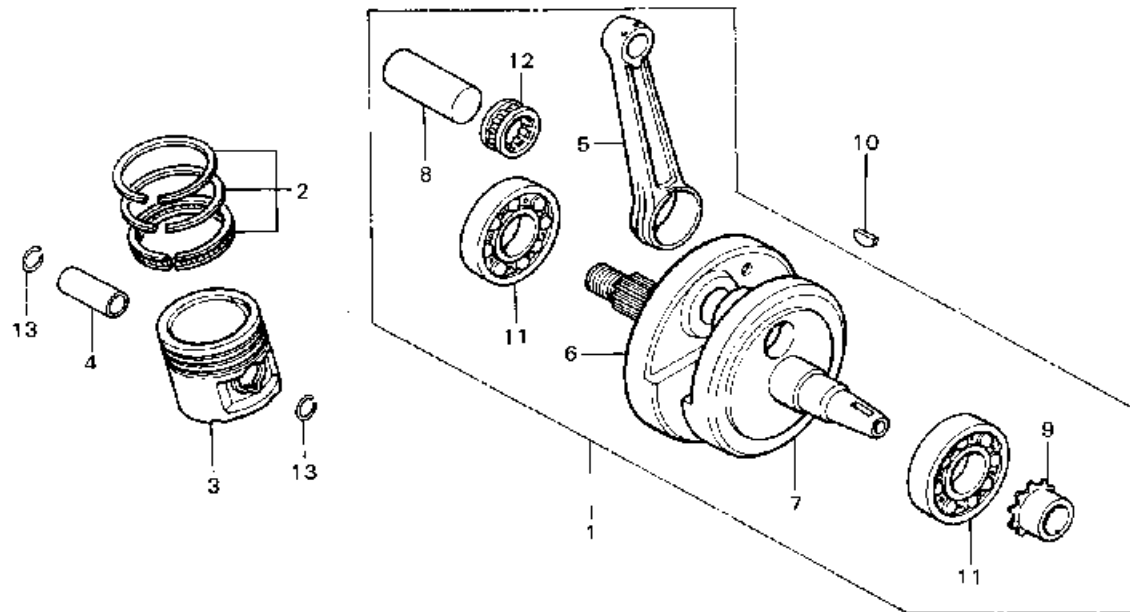

3401-6

Service Item	F.R.T.	Ref. No.	Part No.	Description	Reqd. No. TL125S	Serial No.	Area Code
CONNECTING ROD and its related parts	*	1	13000-355-700	CRANKSHAFT COMP.	1		
★ Actually required time		2	13011-383-000	RING SET, PISTON (STO.)	1		
CRANKSHAFT BALL BEARING	≈4.0		13021-383-000	RING SET, PISTON (0.25)	(1)		
• Add 0.1			13031-383-000	RING SET, PISTON (0.50)	(1)		
CRANKSHAFT COMP.	≈3.9		13041-383-000	RING SET, PISTON (0.75)	(1)		
PISTON and its related parts	≈2.8		13051-383-000	RING SET, PISTON (1.00)	(1)		
		3	13101-355-700	PISTON (STO.)	1		
			13102-355-700	PISTON (0.25)	(1)		
			13103-355-700	PISTON (0.50)	(1)		
			13104-355-700	PISTON (0.75)	(1)		
			13105-355-700	PISTON (1.00)	(1)		
		4	13111-286-000	PIN, PISTON	1		
		5	13201-383-310	ROD, CONNECTING	1		
		6	13310-383-300	CRANKSHAFT COMP., RIGHT	1		
		7	13321-355-700	CRANKSHAFT, LEFT	1		
		8	13381-383-300	PIN, CRANK	1		
		9	14311-107-000	SPROCKET, TIMING (16T)	1		
		10	90741-003-010	KEY, WOODRUFF, 4MM	1		
		11	91001-383-003	BEARING, RADIAL BALL, 6328HS (FUJIKOSHI)	2		
			91001-383-004	BEARING, RADIAL BALL 6328HS (KOYO)	2		
			91001-383-008	BEARING, RADIAL BALL, 6328HS (TOYO)	2		
		12	91002-383-003	BEARING, CONNECTING ROD LARGE END (RED)	1		
			91002-383-004	BEARING, CONNECTING ROD LARGE END (RED)(KOYO)	1		

1976.01.20

C11

C 12

Block No.

E-10

Crankshaft - Piston

www.mustGP.com

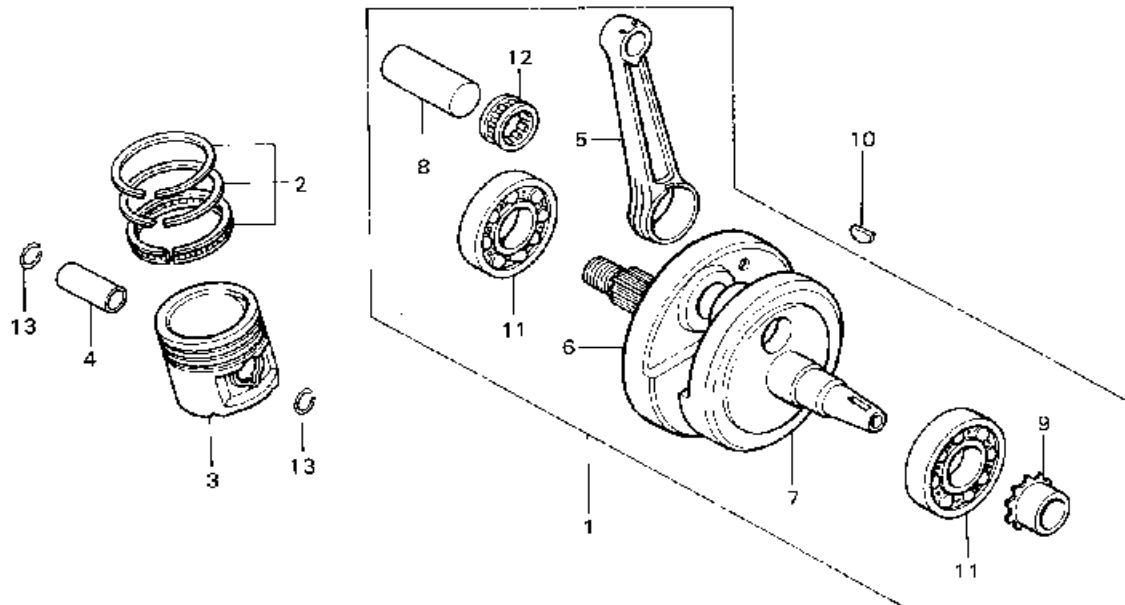

B401-6

Service Item	F.R.T.	Ref. No.	Part No.	Description	Reqd. No. TL125S	Serial No.	Area Code
			91003-383-003	BEARING, CONNECTING ROD LARGE END (BLUE)	1		
			91003-383-004	BEARING, CONNECTING ROD LARGE END (BLUE)(KOYO)	1		
			91004-383-003	BEARING, CONNECTING ROD LARGE END (WHITE)	1		
			91004-383-004	BEARING, CONNECTING ROD LARGE END (WHITE)(KOYO)	1		
Selection table of connecting rod large end bearing							
(Radial clearance C-Hμl)							
		Connecting rod allowance 3/φ					
		Crank pin allowance 30 φ					
			A	B	C	D	E
			+0.001 -0.001	+0.003 0.00*	+0.005 +0.003	+0.007 +0.005	+0.015 +0.007
1 or GREEN	-0.001 -0.001			(R-D) 91002-383-003 91002-383-004			
2 or YELLOW	+0.003 +0.005	(BLUE) 91003-383-003 91003-383-004			(R-F) 91002-383-003 91002-383-004		
3 or WHITE	0.005 +0.005		(BLUE) 91003-383-003 91003-383-004			(R-I) 91002-383-003 91002-383-004	
4 or BLUE	+0.005 +0.007	(WHITE) 91004-383-003 91004-383-004		(BLUE) 91003-383-003 91003-383-004			(R-E) 91002-383-003 91002-383-004
13		94601-15000	CLIP, PISTON PIN, 15MM		2		

1976.01.20

C12

C 13

Block No.

E-11

Transmission -
Kick Starter Spindle

www.CustGP.com

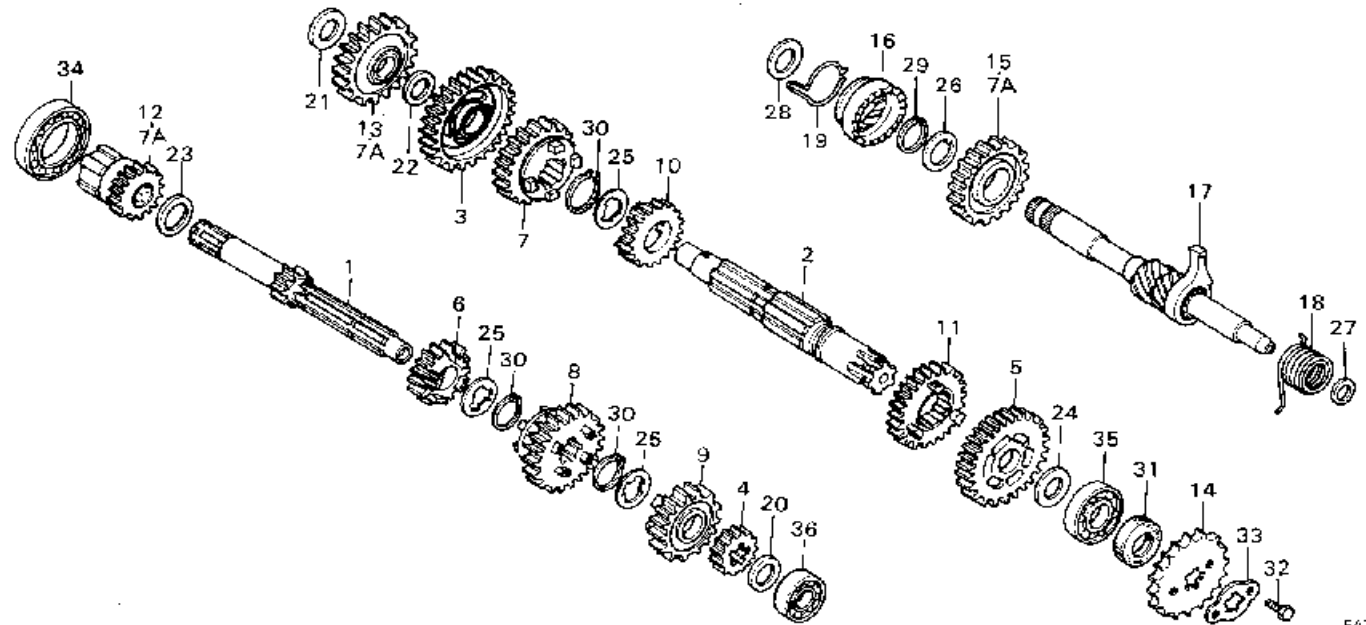

E401-7

Service Item	F.R.T.	Ref. No.	Part No.	Description	Reqd. No. TL125S	Serial No.	Area Code
TRANSMISSION MAINSHAFT and related parts	3.8	1	23211-383-000	MAINSHAFT, TRANSMISSION (11T)	1		
• TRANSMISSION COUNTER SHAFT and its related parts		2	23221-107-000	SHAFT, TRANSMISSION COUNTER	1		
KICK STARTER PINION and its related parts	3.7	3	23421-383-000	GEAR COMP., COUNTERSHAFT LOW (36T)	1		
DRIVE SPROCKET	0.2	4	23441-355-000	GEAR, MAINSHAFT SECOND (16T)	1		
		5	23451-355-000	GEAR, COUNTERSHAFT SECOND (34T)	1		
		6	23461-383-000	GEAR, MAINSHAFT THIRD (20T)	1		
		7	23471-383-000	GEAR, COUNTERSHAFT THIRD (29T)	1		
		7A	23500-383-000	GEAR SET, KICK STARTER	(1)		
		8	23501-355-010	GEAR, MAINSHAFT TOP (29T)	1		
		9	23501-383-000	GEAR, MAINSHAFT FIFTH (25T)	1		
		10	23511-355-000	GEAR, COUNTERSHAFT TOP (21T)	1		
		11	23511-383-000	GEAR, COUNTERSHAFT FIFTH (25T)	1		
		12	23520-383-000	GEAR COMP., STARTER (19T)	1		
		13	23530-383-000	GEAR COMP., IDLE STARTER (29T)	1		
		14	23801-324-000	SPROCKET, DRIVE (15T)	1		
		15	28211-383-000	PINION, KICK STARTER (29T)	1		
		16	28221-107-010	RATCHET, KICK STARTER DRIVE	1		
		17	28250-365-000	SPINDLE COMP., KICK STARTER	1		
		18	28261-107-000	SPRING, KICK STARTER	1		
		19	28271-107-000	SPRING, STARTER PINION	1		
		20	90451-107-000	FRICION WASHER, THRUST, 15 MM	1		
		21	90451-365-000	WASHER, THRUST, 15MM	1		
		22	90452-107-000	WASHER, THRUST, 16.5 MM	1		

1976-D1-20

C13

C 14

Block No.

E-11

Transmission -
Kick Starter Spindle

www.mustGP.com

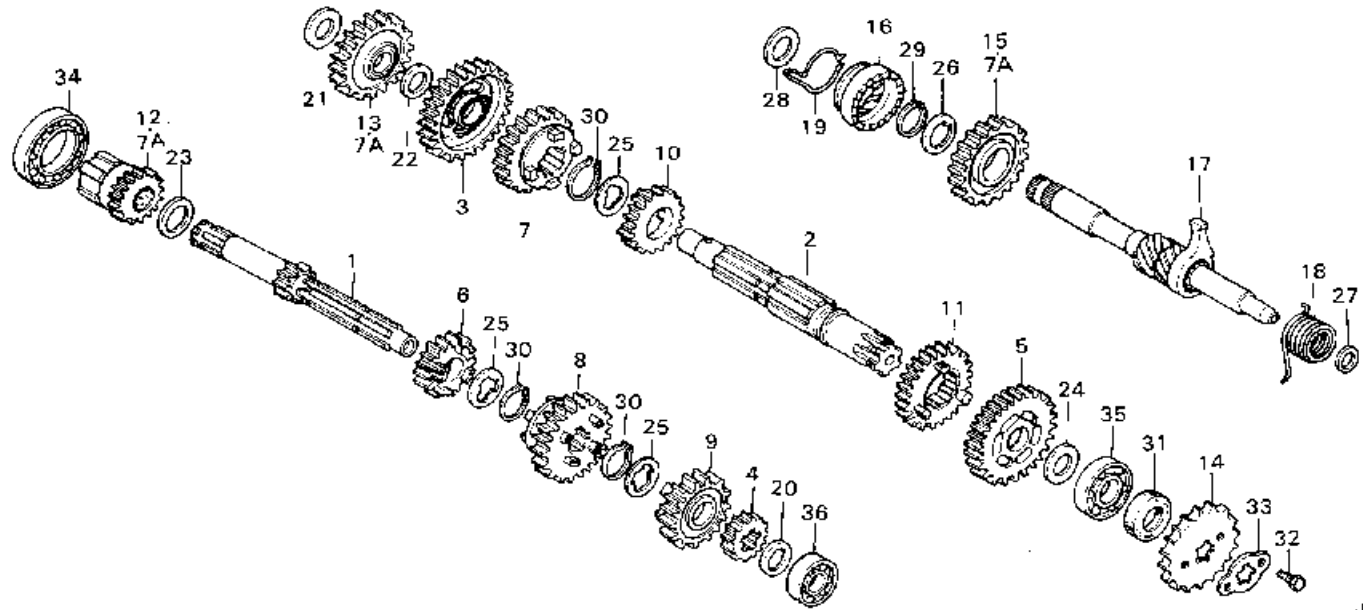

J401

Service Item	F.R.T.	Ref. No.	Part No.	Description	Reqd. No. TL125S	Serial No.	Area Code
		23	90453-107-000	WASHER A; THRUST; 20 MM	1		
		24	90454-107-000	WASHER B; THRUST; 20 MM	1		
		25	90455-107-000	WASHER A; SPLINE; 20 MM	3		
		26	90458-107-000	WASHER; THRUST; 25MM	1		
		27	90459-107-000	WASHER; THRUST; 12 MM	1		
		28	90462-107-000	WASHER; THRUST; 16 MM	1		
		29	90601-107-000	CIR-CLIP 25MM	1		
		30	90605-200-000	SET RING; 20MM	3		
		31	91201-030-003	OIL SEAL; 20X34X7	1		
			91201-030-005	OIL SEAL; 20X34X7	1		
		32	92000-06010	BOLT; HEX.; 6X10	2		
		33	95014-92100	PLATE; DRIVE SPROCKET FIXING	1		
		34	96100-60060	BEARING; BALL; 6006	1		
		35	96100-62040	BEARING; RADIAL BALL; 6204	1		
		36	96120-62020	BEARING; BALL; 6202	1		

1976.01.20

C.14

C 15

Block No.

E-12

Shift Drum - Spindle

www.mustGP.com

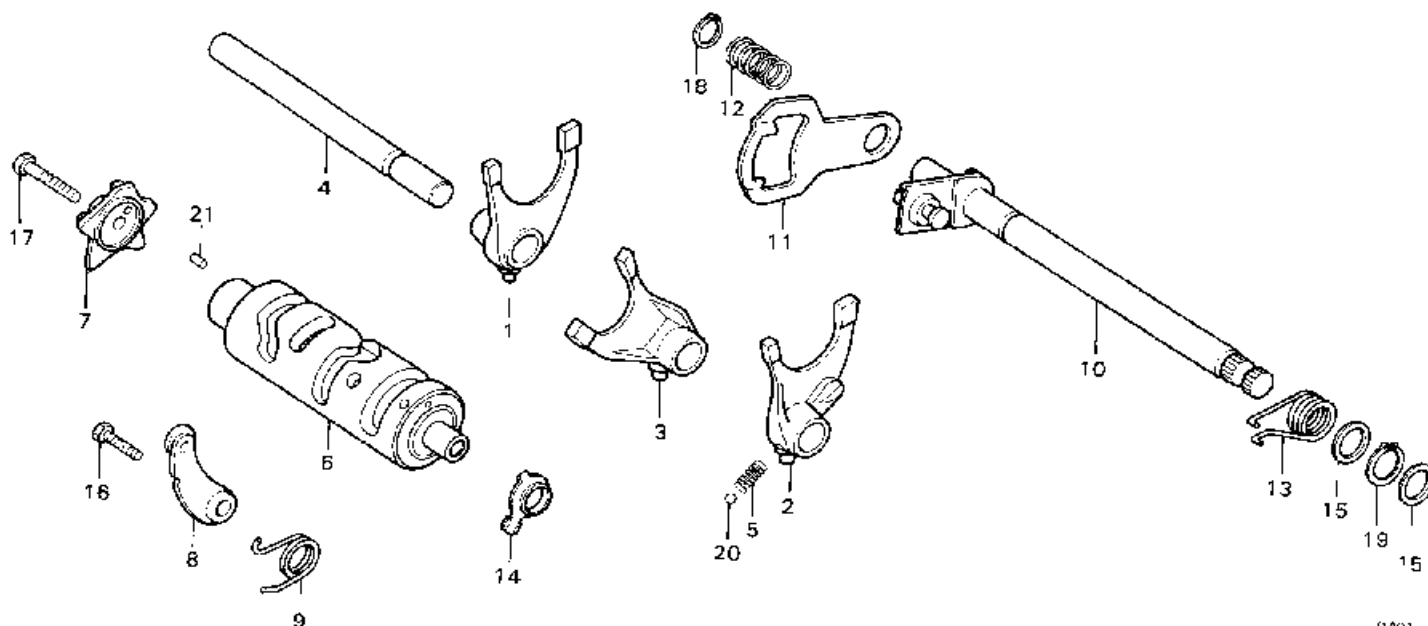

B401-9

Service Item	F.R.T.	Ref. No.	Part No.	Description	Reqd. No. TL125S	Serial No.	Area Code
GEAR SHIFT FORK/DRUM and those related parts	*3.8	1	24211-107-000	FORK; RIGHT GEAR SHIFT	1		
		2	24221-355-000	FORK; LEFT GEAR SHIFT	1		
GEAR SHIFT SPINDLE/GEAR SHIFT CAM and those related parts	0.9	3	24231-107-000	FORK; CENTER GEAR SHIFT	1		
		4	24241-107-000	SHAFT; GEAR SHIFT FORK GUIDE	1		
		5	24271-355-000	SPRING; BALL SET	1		
		6	24301-355-000	DRUM; GEAR SHIFT	1		
		7	24411-107-000	CAM; GEAR SHIFT	1		
		8	24430-324-000	STOPPER COMP.; GEAR SHIFT DRUM	1		
		9	24435-383-000	SPRING; SHIFT DRUM STOPPER	1		
		10	24610-107-760	SPINDLE COMP.; GEAR SHIFT	1		
		11	24621-107-760	PLATE; GEAR SHIFT	1		
		12	24631-107-000	SPRING; GEAR SHIFT PLATE	1		
		13	24651-107-000	SPRING; GEAR SHIFT RETURN	1		
		14	35753-02B-601	ROTOR; NEUTRAL SWITCH	1		
		15	90451-001-000	WASHER; THRUST; 14MM	2		
		16	92000-06020	BOLT; HEX.; 6X20	1		
		17	92000-06025	BOLT; HEX.; 6X25	1		
		18	94510-12000	RING; EXTERNAL SNAP; 12MM	1		
		19	94510-14000	CIR CLIP; EXTERNAL; 14MM	1		
		20	96211-08000	BALL; STEEL; #8	1		
		21	96220-40100	ROLLER; 4X10	1		

1976.01.20

C15

C 16

Block No.

E-13

Carburetor

www.ustGP.com

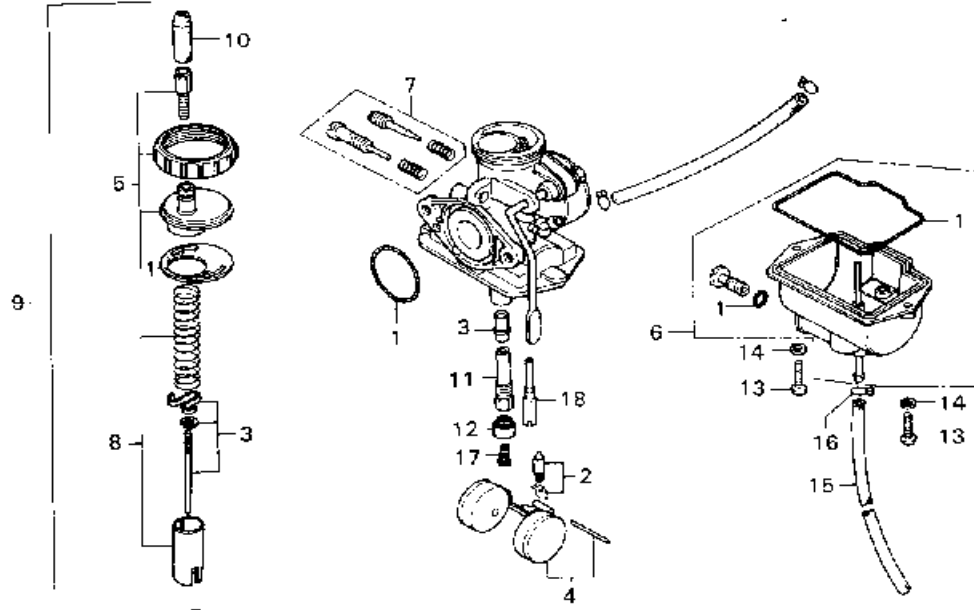

B401-9

Service Item	F.R.T.	Ref. No.	Part No.	Description	Reqd. No. TL1255	Serial No.	Area Code
CARBURETOR ASSY.	0.4	1	16010-116-700	PACKING SET	1		
JET NEEDLE SET	0.6	2	16011-143-620	VALVE SET, FLOAT	1		
FLOAT VALVE SET/FLOAT SFT	0.5	3	16012-355-700	NEEDLE SET, JET	1		
THROTTLE VALVE SET	0.3	4	16013-116-700	FLOAT SET	1		
TOP SFT	0.2	5	16014-116-700	TOP SET	1		
• SCREW SET		6	16015-116-700	CHAMBER SET, FLOAT	1		
• MAIN JET/SLOW JET		7	16016-143-620	SCREW SET	1		
		8	16022-355-700	VALVE SET, THROTTLE	1		
		9	16100-355-700	CARBURETOR ASSY.	1		
		10	16118-086-004	CAP, CABLE	1		
		11	16165-355-700	HOLDER, NEEDLE JET	1		
		12	16168-355-700	HOLDER, JET	1		
		13	93500-04012-0A	SCREW, PAN, 4X12	2		
		14	94111-04000	WASHER, SPRING, 4MM	2		
		15	96001-35390-40	TUBE, FUEL, 3.5X390	1		
		16	95002-02070	CLIP, FUEL TUBE, B7	1		
		17	99101-116-0920	JET, MAIN (#92)	1		
		18	99103-355-0350	JET, SLOW (#35)	1		

1976.01.2C

C15

G 2

Block No.

F-1

Head Light (E,ED)

www.mustGP.com

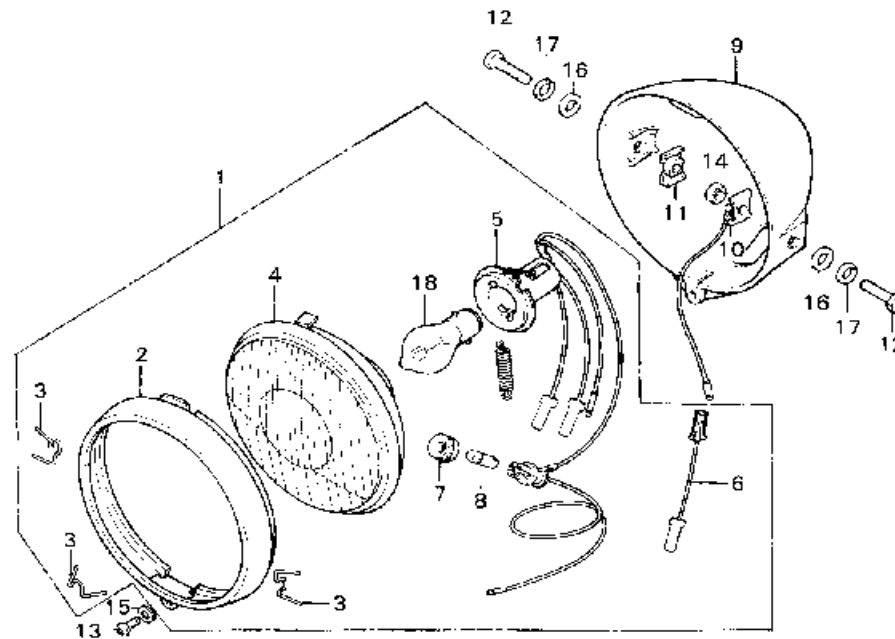

B375 30

Service Item	F.R.T.	Ref. No.	Part No.	Description	Reqd. No. TL125S	Serial No.	Area Code
HEAD LIGHT CASE	0.3	1	33100-107-612	LIGHT ASSY., HEAD (STANLEY)	1		E,ED
HEAD LIGHT UNIT and its related parts	0.2	2	33101-237-600	RIM, HEAD LIGHT	1		E,ED
HEAD LIGHT ASSY.	0.1	3	33108-268-000	SPRING, HEAD LIGHT LENS SET	3		F,ED
• BULB		4	33120-304-611	LIGHT UNIT, HEAD	1		F,ED
• POSITION LAMP SUB CORD		5	33130-237-600	SOCKET, HEAD LIGHT	1		F,ED
		6	33164-107-600	CORD, POSITION LAMP SUB	1		E,ED
		7	33905-303-003	RUBBER, JOINT	1		E,ED
		8	34902-202-600	BULB, DASH (6V 4W) (LOCAL PROCUREMENT)	1		E,ED
		9	61301-391-000B	CASE, HEAD LIGHT	1		E,ED
		10	61303-074-000	WASHER, HEAD LIGHT CASE	1		C,ED
		11	61303-105-000	WASHER, HEAD LIGHT CASE	1		E,ED
		12	92000-08025-08	BOLT, HEX., 8X25	2		E,ED
		13	93500-05012-1A	SCREW, PAN, 5X12	1		E,ED
		14	94001-08000-0S	NUT, HEX., 8MM	1		E,ED
		15	94101-05000	WASHER, PLAIN, 5MM	1		E,ED
		16	94101-08000	WASHER, PLAIN, 8MM	2		F,ED
		17	94111-08000	WASHER, SPRING, 8MM	2		E,ED
		18		BULB, HEAD LIGHT (LOCAL PROCUREMENT)	1		E,ED

1976.01.20

G2



Block No.

F-1-1

Head Light (F)

www.ustGP.com

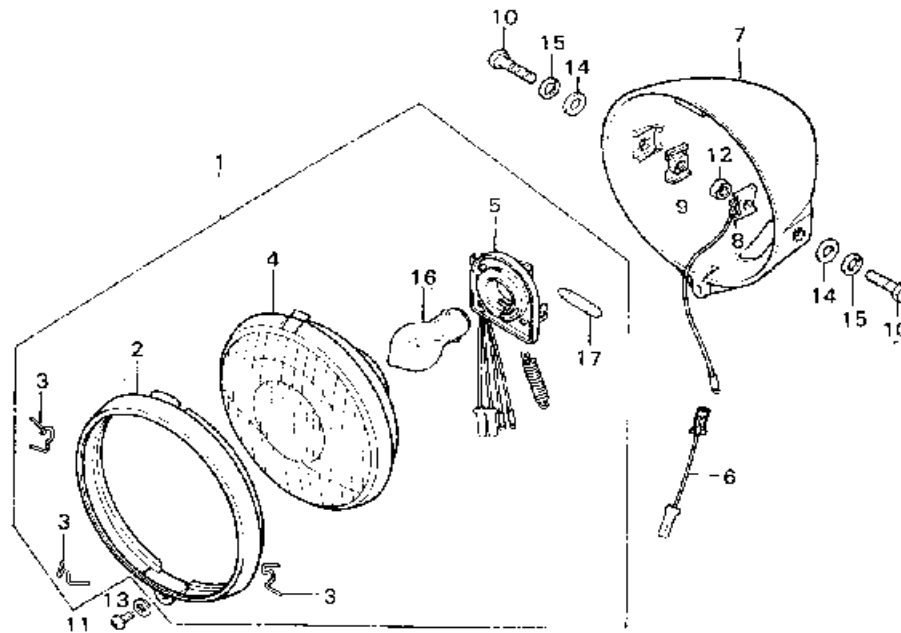

3055-01

Service Item	F.R.T.	Ref. No.	Part No.	Description	Reqd. No. TL125S	Serial No.	Area Code
HEAD LIGHT CASE	0.3	1	33100-383-621	LIGHT ASSY., HEAD (6V 35/35W-4W)	1		F
HEAD LIGHT UNIT and its related parts	0.2	2	33101-230-621	RIM, HEAD LIGHT	1		F
HEAD LIGHT ASSY.	0.1	3	33108-324-621	SPRING, UNIT HOLDER	3		F
• BULB		4	33120-230-621	LIGHT UNIT, HEAD	1		F
		5	33130-286-622	SOCKET, HEAD LIGHT	1		F
		6	33164-107-600	CORD, POSITION LAMP SUB	1		F
		7	61301-391-000B	CASE, HEAD LIGHT	1		F
		8	61303-074-000	WASHER, HEAD LIGHT CASE	1		F
		9	61303-105-000	WASHER, HEAD LIGHT CASE	1		F
		10	92000-08025-08	BOLT, HEX., 8X25	2		F
		11	93500-05012-1A	SCREW, PAN, 5X12	1		F
		12	94001-08000-05	NUT, HEX., 8MM	1		F
		13	94101-05000	WASHER, PLAIN, 5MM	1		F
		14	94101-08000	WASHER, PLAIN, 8MM	2		F
		15	94111-08000	WASHER, SPRING, 8MM	2		F
		16		BULB, HEAD LIGHT (LOCAL PROCUREMENT)	1		F
		17		BULB, MARKER LIGHT (LOCAL PROCUREMENT)	1		F

1976.01.20

G3

FRAME GROUP

G 4

Block No.

F-1-2

Head Light (U)

www.CustGP.com

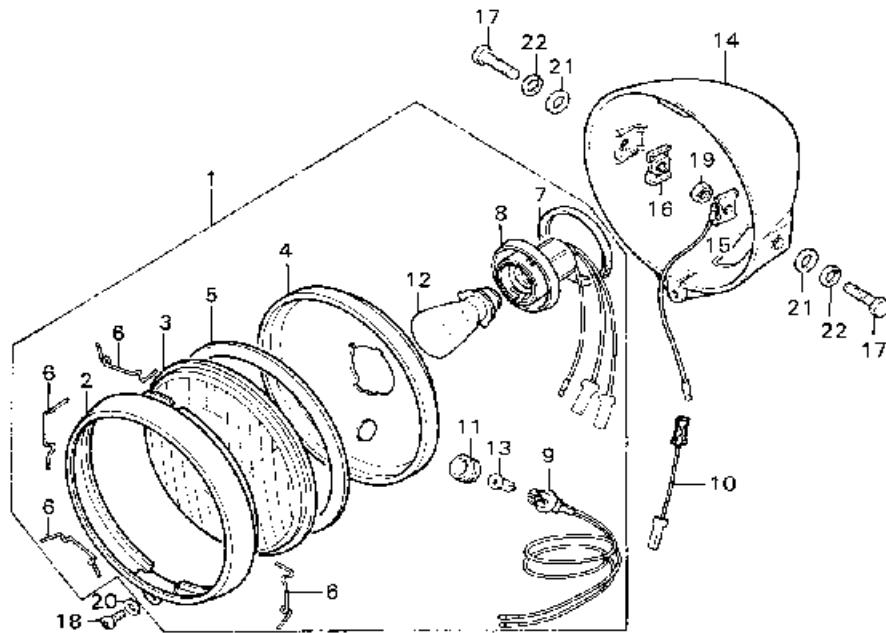

5355-39

Service Item	F.R.T.	Ref. No.	Part No.	Description	Reqd. No. TL125S	Serial No.	Area Code
HEAD LIGHT CASE	0.3	1	33100-401-681	LIGHT ASSY., HEAD (6V 35/36W)	1		U
HEAD LIGHT LENS and its related parts	0.2	2	33101-229-000	RIM, HEAD LIGHT	1		U
		3	33103-070-000	LENS, HEAD LIGHT	1		U
HEAD LIGHT ASSY.	0.1	4	33104-105-000	REFRACTOR, HEAD LIGHT	1		U
• BULB		5	33105-070-000	PACKING, HEAD LIGHT LENS	1		U
• MARKER LIGHT SOCKET ASSY.		6	33108-229-003	SPRING, UNIT HOLDER	4		U
		7	33109-567-003	PACKING, SOCKET	1		U
		8	33130-229-000	SOCKET, HEAD LIGHT	1		U
		9	33140-105-003	SOCKET ASSY., MARKER LIGHT	1		U
		10	33164-107-600	CORD, POSITION LAMP SUB	1		U
		11	33905-303-003	RUBBER, JOINT	1		U
		12	34901-329-003	BULB, HEAD LIGHT	1		U
		13	34903-303-003	BULB, POSITION (6V 3W AMBER)	1		U
		14	61301-391-000B	CASE, HEAD LIGHT	1		U
		15	61303-074-000	WASHER, HEAD LIGHT CASE	1		U
		16	61303-105-000	WASHER, HEAD LIGHT CASE	1		U
		17	92000-08025-00B	BOLT, HEX., 8X25	2		U
		18	93500-05012-1A	SCREW, PAN., 5X12	1		U
		19	94001-08000-0S	NUT, HEX., 8MM	1		U
		20	94101-05000	WASHER, PLAIN, 5MM	1		U
		21	94101-08000	WASHER, PLAIN, 8MM	2		U
		22	94111-08000	WASHER, SPRING, 8MM	2		U

1976.01.20

G4

G 5

Block No.

F-2

**Speedometer •
Head Light Bracket •
Horn**

www.CustGP.com

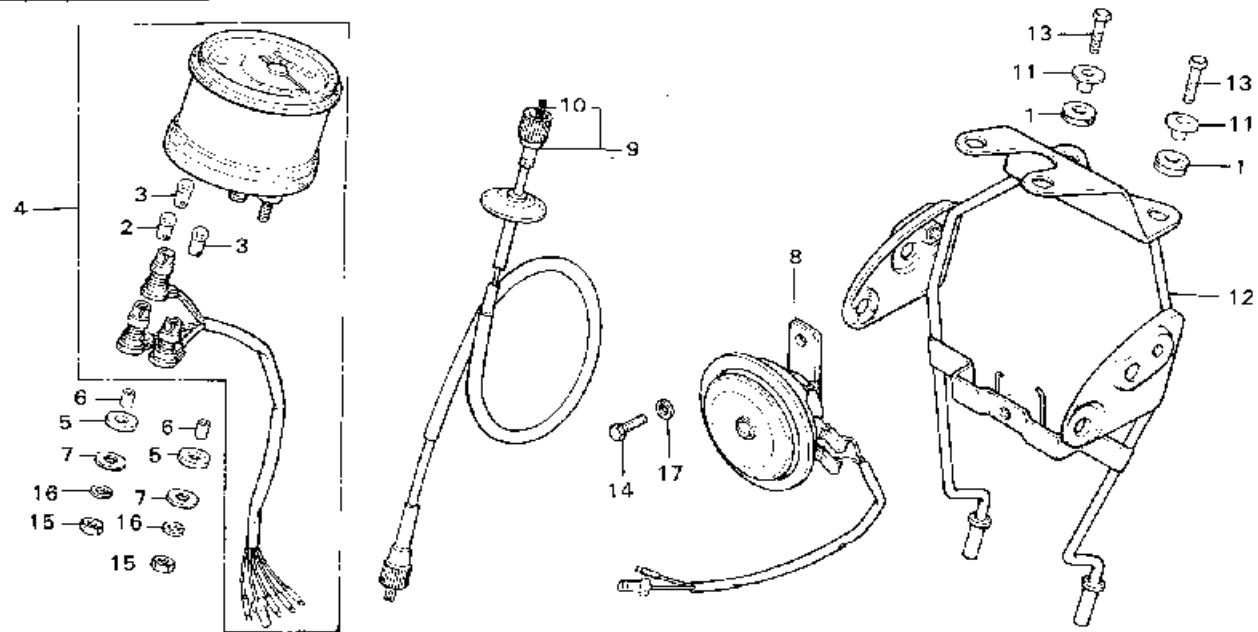

B356 33

Service Item	F.R.T.	Ref. No.	Part No.	Description	Reqd. No. TL125S	Serial No.	Area Code
HEAD LIGHT BRACKET	0.5	1	17245-107-010	RUBBER; AIR DEFLECTOR CASE MOUNT	2		
SPEEDOMETER ASSY.	0.2	2	34902-202-000	BULB; DASH (6V 3W)	1		
• HORN ASSY.		3	34908-230-000	BULB; SPEEDOMETER (6V 1.7W)	2		
• SPEEDOMETER CABLE ASSY.		4	37200-355-601	SPEEDOMETER ASSY. (MILE)	1		E
SPEEDOMETER INNER CABLE	0.1	5	37200-355-611	SPEEDOMETER ASSY. (KM)	1		FD,F,U
• METER BULB		6	37311-061-810	RUBBER B; SPEEDOMETER CUSHION	2		
		6	37312-051-740	COLLAR; SPEEDOMETER CUSHION	2		
		7	37314-061-810	WASHER; PLAIN; 5.5MM	2		
		8	38100-382-601	HORN ASSY.	1		
		9	44830-355-620	CABLE ASSY.; SPEEDOMETER	1		
		10	44832-355-620	CABLE; SPEEDOMETER INNER	1		
		11	61104-357-000	COLLAR; FRONT FENDER	2		
		12	61311-355-620	BRACKET; HEAD LIGHT	1		
		13	92000-06025	BOLT; HEX.; 6X25	2		
		14	92000-08016-0A	BOLT; HEX.; 8X16	1		
		15	94001-05000-0S	NUT; HEX.; 5MM	2		
		16	94111-05000	WASHER; SPRING; 5MM	2		
		17	94111-08000	WASHER; SPRING; 8MM	1		

1976.01.20

65

G 6

Block No.

F-3

**Handle Switch ·
Lever · Cable**

www.mustGP.com

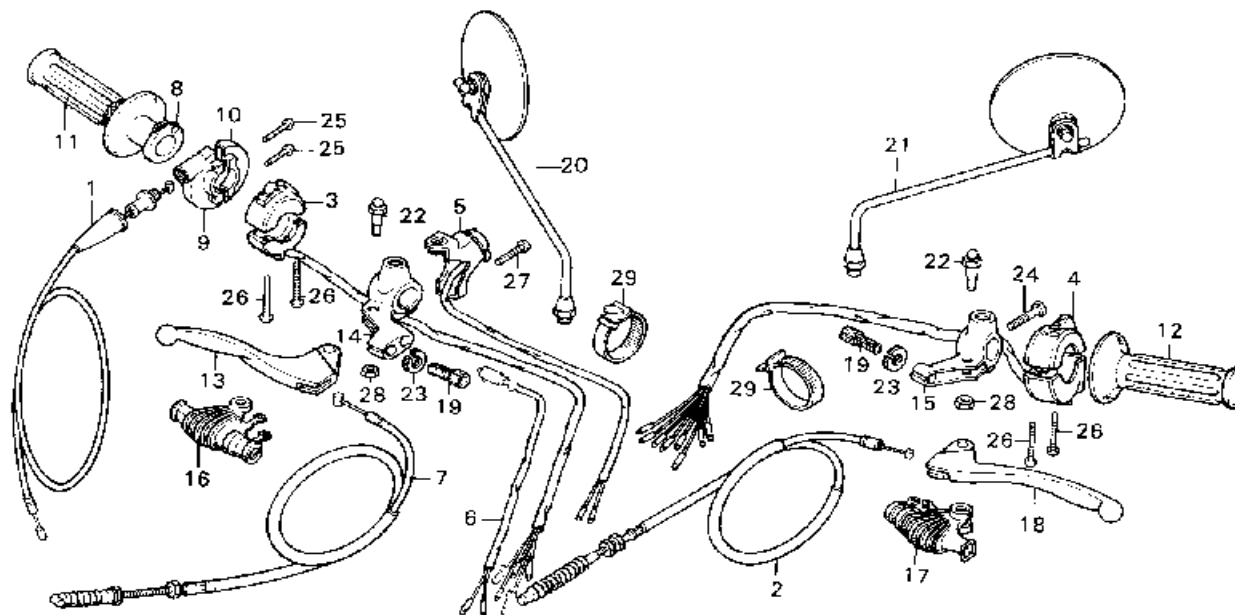

B355-34

Service Item	F.R.T.	Ref. No.	Part No.	Description	Reqd. No. TL1255	Serial No.	Area Code
THROTTLE CABLE	0.4	1	17910-355-000	CABLE COMP., THROTTLE	1		
UPPER CASE	0.3	2	22870-355-010	CABLE COMP., CLUTCH	1		
CLUTCH CABLE	0.2	3	35150-401-681	SWITCH ASSY., LIGHTING	1		
• FRONT STOP SWITCH		4	35200-358-003	SWITCH, WINKER DIMMER (TOYO)	1		
• LIGHTING SWITCH		5	35320-358-003	SWITCH ASSY., KILL (TOYO)	1		
• KILL SWITCH		6	35330-401-681	SWITCH ASSY., FRONT STOP	1		
• WINKER DIMMER SWITCH		7	45450-355-000	CABLE COMP., FRONT BRAKE	1		
• FRONT BRAKE CABLE		8	53141-355-000	PIPE, THROTTLE GRIP	1		
• THROTTLE GRIP PIPE		9	53143-355-000	UPPER, CASE	1		
• R/L HANDLE LEVER BRACKET		10	53144-355-000	LOWER, CASE	1		
LOWER CASE	0.1	11	53165-116-670	RUBBER, RIGHT HANDLE	1		
• HANDLE RUBBER		12	53166-116-670	RUBBER, LEFT HANDLE	1		
• HANDLE LEVER and its related parts		13	53170-369-700	LEVER COMP., RIGHT STEERING HANDLE	1		
BACK MIRROR	0.1	14	53171-312-003	BRACKET, RIGHT HANDLE LEVER	1		
• One or a-l		15	53172-310-010	BRACKET, LEFT HANDLE LEVER	1		
		16	53176-329-000	COVER, RIGHT STEERING HANDLE LEVER	1		
		17	53179-329-000	COVER, LEFT STEERING HANDLE LEVER	1		
		18	53190-369-700	LEVER COMP., LEFT STEERING HANDLE	1		
		19	53192-268-000	BOLT, CLUTCH WIRE ADJUSTING	2		
		20	88110-304-621	MIRROR, RIGHT BACK	1		F
			88100-375-770	MIRROR, RIGHT BACK	1		E, ED
			88100-401-680	MIRROR, RIGHT BACK	1		U

1976.01.20

G6

G 7

Block No.

F-3

**Handle Switch -
Lever - Cable**

www.mustGP.com

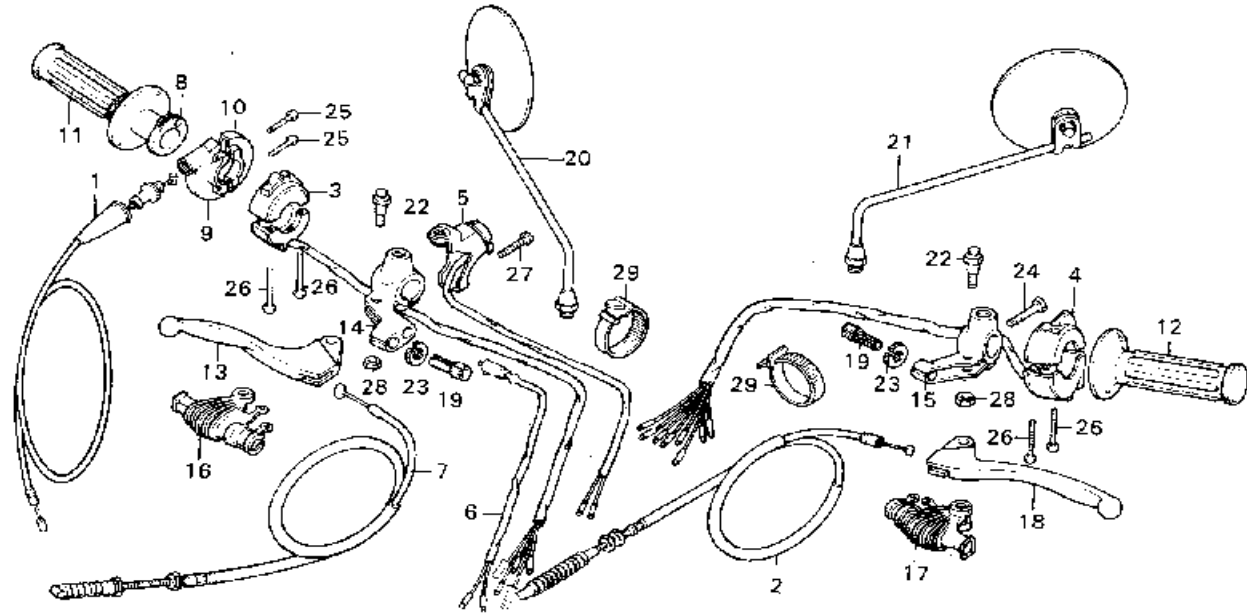

3350-34

Service Item	F.R.T.	Ref. No.	Part No.	Description	Reqd. No. TL125S	Serial No.	Area Code
		21	88120-375-770	MIRROR, LEFT BACK	1		E+EU
			88120-304-621	MIRROR, LEFT BACK	1		F
			88120-369-650	MIRROR, LEFT BACK	1		U
		22	90114-329-000	BOLT, HANDLE LEVER PIVOT	2		
		23	90321-268-000	NUT, FIXING	2		
		24	92000-06025	BOLT, HEX., 6X25	1		
		25	93500-05020-1A	SCREW, PAN, 5X20	2		
		26	93500-05028-0A	SCREW, PAN, 5X28	4		
		27	93500-06028	SCREW, PAN, 6X28	1		
		28	94001-06000	NUT, HEX., 6MM	2		
		29	95014-62100	BAND BT, WIRE	2		

1976.01.20

G7

G 9

Block No.

F-4

**Steering Handle -
Top Bridge - Stem**

www.ustGP.com

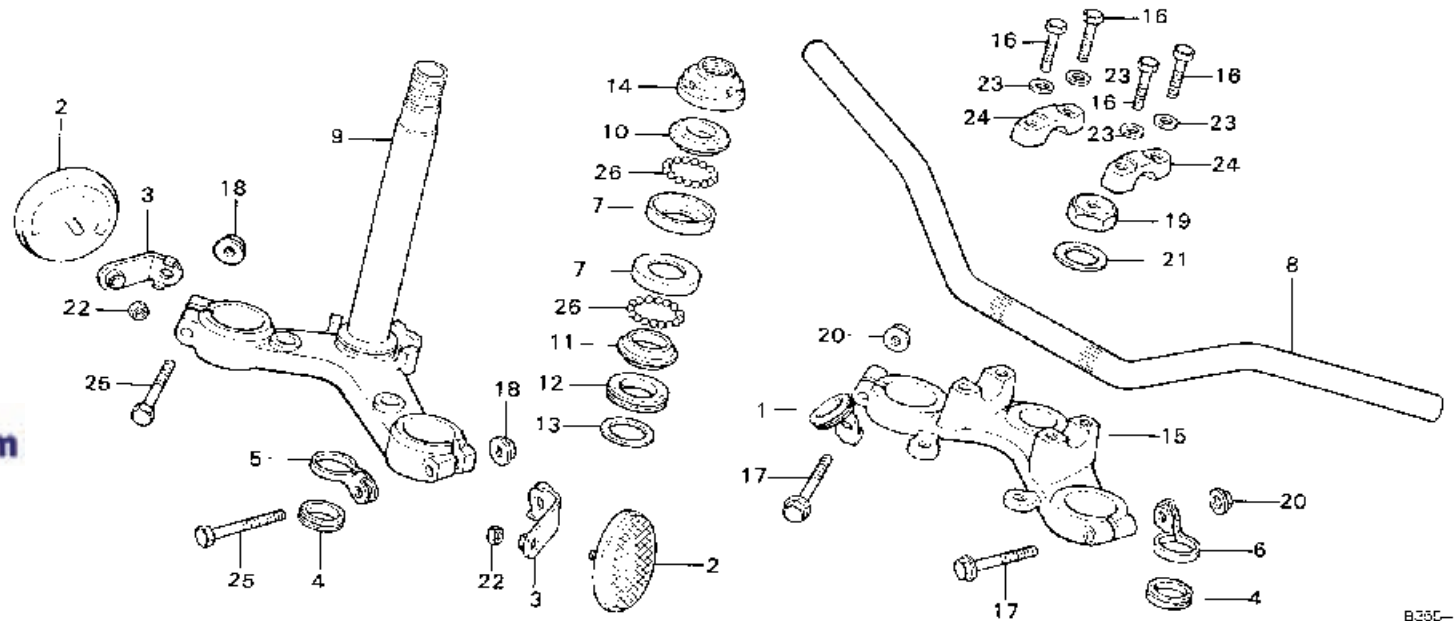

B335-3b

Service Item	F.R.T.	Ref. No.	Part No.	Description	Req'd. No. TL125S	Serial No.	Area Code
		25	95100-08032 95130-08045	BOLT, HEX., 8X32 BOLT, HEX., 8X45	2 2		F E+EJ,U
		26	96211-06000	BALL, STEEL, #6	42		

1976.01.20

G9

G 10

Block No.

F-5

Front Fender

www.ustGP.com

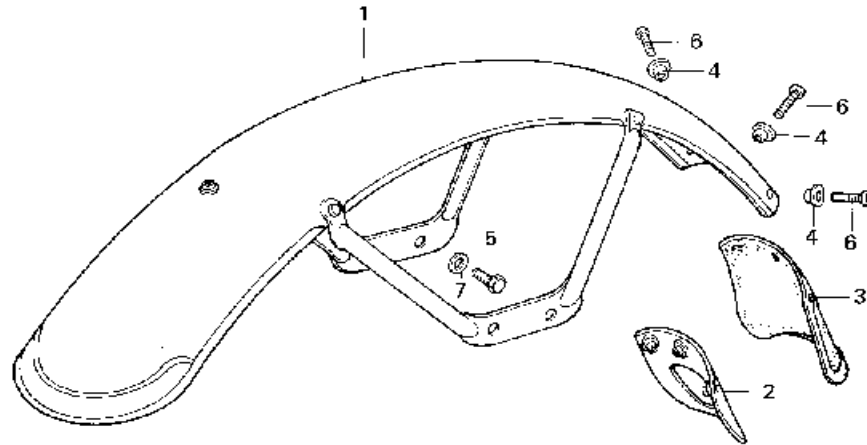

6392 29

Service Item	F.R.T.	Ref. No.	Part No.	Description	Reqd. No. TL1255	Series No.	Area Code
FRONT FENDER	0.3	1	61100-355-620ZA	FENDER COMP., FRONT *NF-24*	1		
FRONT MUD GUARD	0.2	2	61105-355-000	PLATE, FRONT FENDER MUDGUARD	1		
		3	61114-033-000	MUDGUARD, FRONT	1		
		4	90522-028-000	WASHER, CHAIN CASE SETTING	3		
		5	92000-06012	BOLT, HEX., 6X12	4		
		5	93500-06014	SCREW, PAN, 6X14	3		
		7	94101-06000	WASHER, PLAIN, 6MM	6		

1976.01.20

G10

G 11

Block No.

F-6

Front Fork

www.mustGP.com

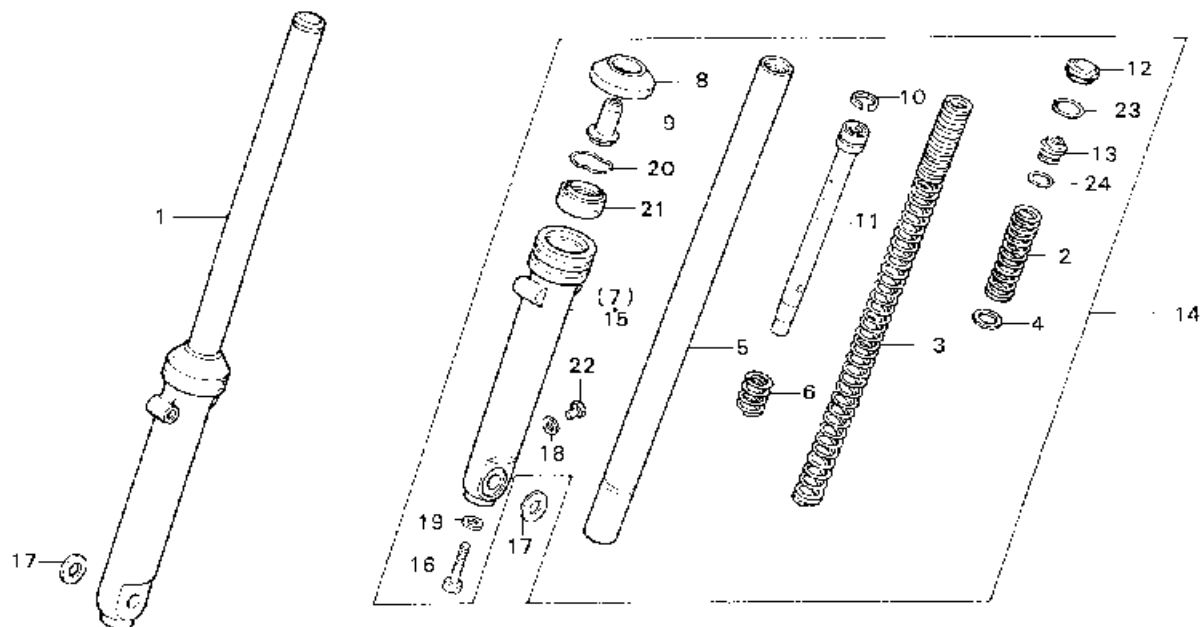

B355-26

Service Item	F.R.T.	Ref. No.	Part No.	Description	Reqd. No. 1L12bS	Serial No.	Area Code
FRONT FORK PIPE/BOTTOM CASE and those related parts * Add 0.3	0.7	1	51400-355-023	FORK ASSY., RIGHT FRONT	1		
		2	51401-355-000	SPRING A; FRONT CUSHION	2		
		3	51402-355-000	SPRING B; FRONT CUSHION	2		
		4	51403-362-010	PLATE; SPRING JOINT	2		
		5	51410-355-013	PIPE COMP., FRONT FORK	2		
FRONT FORK ASSY./DUST SEAL * One motorcycle 0.5	0.4	6	51412-331-770	SPRING; FRONT CUSHION REBOUND	2		
		7	51421-355-003	CASE; RIGHT FORK BOTTOM	1		
FRONT CUSHION SPRING	0.2	8	51425-110-003	SEAL; FRONT FORK DUST	2		
		9	51432-453-000	PIECE; OIL LOCK	2		
		10	51437-331-770	RING; PISTON	2		
		11	51440-355-003	SEAT COMP., UNDER	2		
		12	51449-355-003	CAP; FORK PIPE	2		
		13	51454-355-013	SEAT; UPPER SPRING	2		
		14	51500-355-023	FORK ASSY., LEFT FRONT	1		
		15	51521-355-003	CASE; LEFT FORK BOTTOM	1		
		16	90116-283-010	BOLT; SOCKET; 8MM	2		
		17	90528-110-000	WASHER; PLAIN; 12MM	2		
		18	90543-273-000	PACKING; FRONT FORK DRAIN COCK	2		
		19	90544-283-000	WASHER; SPECIAL; 8MM	2		
		20	90601-354-000	RING; OIL SEAL STOP	2		
		21	91255-331-671	OIL SEAL; 31X43X12.5	2		
		22	92000-06008	BOLT; HEX.; 6X8	2		
23	94520-26000	CIR CLIP; INTERNAL; 26MM	2				
24	94608-40000	O-RING; 19.4X2.8	2				

1976.01.20

G11

G 12

Block No.

F-7

Front Wheel - Panel

www.CustGP.com

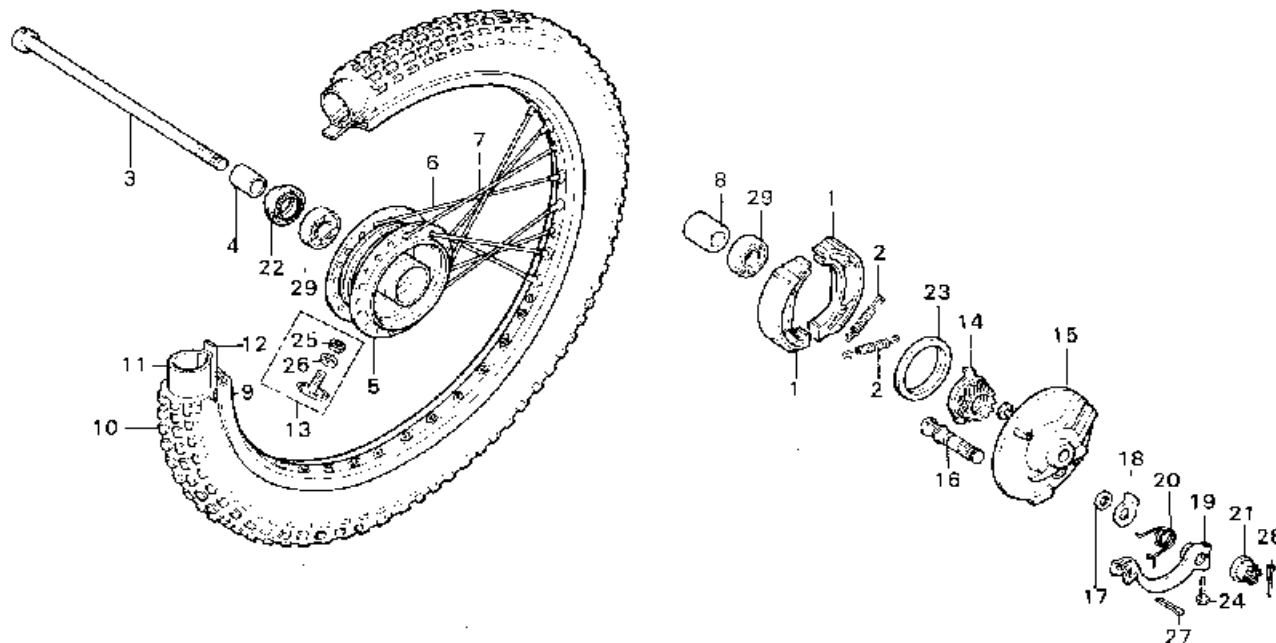

0356-37

Service Item	F.R.T.	Ref. No.	Part No.	Description	Reqd. No. TL125S	Serial No.	Area Code
FRONT WHEEL HUB	3.0	1	43120-365-671	SHOE COMP., BRAKE	2		
FRONT WHEEL RIM	2.2		43120-365-672	(NIPPON BRAKE LINING) SHOE COMP., BRAKE	2		
FRONT WHEEL TIRE/TUBE/TIRE FLAP/ BEAD STOPPER	0.9	2	43151-110-000	SPRING, BRAKE SHOE	2		
FRONT BRAKE PANEL COMP. and its related parts	0.4	3	44301-110-303	AXLE, FRONT WHEEL	1		
FRONT AXLE DISTANCE COLLAR/ BALL BEARING	0.4	4	44311-229-000	COLLAR, FRONT WHEEL SIDE	1		
* Add 0.1 at ball bearing		5	44601-355-000	HUB COMP., FRONT WHEEL	1		
SPEEDOMETER GEAR	0.3	6	44606-360-000	SPOKE A, FRONT (INSIDE)	18		
FRONT WHEEL AXLE and its related parts	0.2	7	44607-360-000	SPOKE B, FRONT (OUTSIDE)	18		
FRONT BRAKE ARM and its related parts	0.1	8	44620-030-000	COLLAR, FRONT AXLE DISTANCE	1		
		9	44701-355-003	RIM, FRONT WHEEL	1		
		10	44711-362-003	TIRE, FRONT (2.75-21 BS)	1		
			44711-362-006	TIRE, FRONT (2.75-21 NITTO)	1		
		11	44712-331-671	TUBE, TIRE (2.75-21 NITTO)	1		
			44712-340-003	TUBE, FRONT WHEEL (2.75/3.00-21 BS)	1		
		12	44713-329-003	FLAP, TIRE (BS)	1		
			44713-331-671	FLAP, TIRE (1.60x21 NITTO)	1		
		13	44715-355-006	STOPPER, FRONT WHEEL TIRE BEAD 1.40 (NITTO)	1		
		14	44804-355-003	GEAR COMP., SPEEDOMETER	1		
		15	45010-355-000	PANEL COMP., FRONT BRAKE	1		
		16	45131-364-670	CAM, FRONT BRAKE	1		
		17	45134-121-000	SEAL, DUST	1		

1976.01.20

012

G 13

Block No.

F-7

Front Wheel - Panel

www.mustGP.com

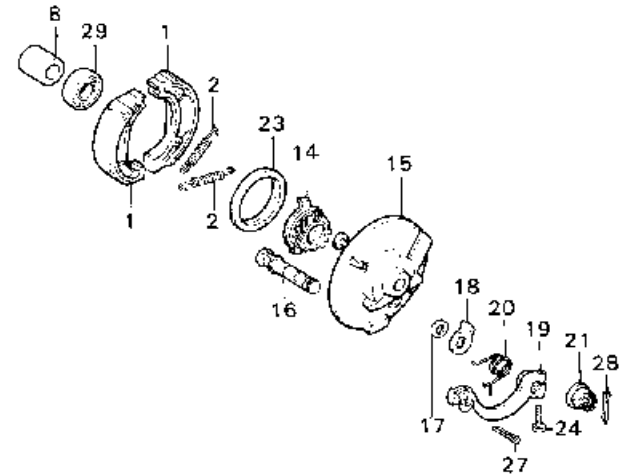
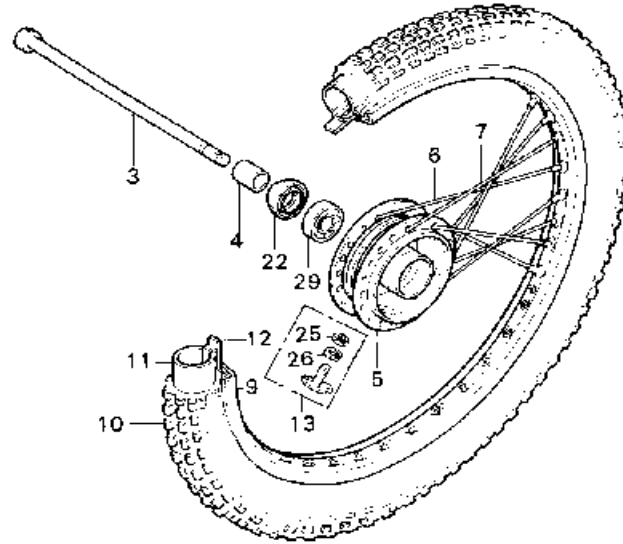

5.355-37

Service Item	F.R.T.	Ref. No.	Part No.	Description	Reqc. No. TL125S	Serial No.	Area Code
		18	45145-364-670	INDICATOR, FRONT BRAKE	1		
		19	45410-364-671	ARM COMP., FRONT BRAKE	1		
		20	45411-087-820	SPRING, FRONT BRAKE ARM RETURN	1		
		21	90305-051-000	NUT, REAR AXLE	1		
		22	90755-229-003	OIL SEAL, 21X37X7	1		
			90755-229-005	OIL SEAL, 21X37X7	1		
		23	91251-121-000	OIL SEAL, 47X60X7	1		
		24	92000-06020	BOLT, HEX., 6X20	1		
		25	94001-08000	NUT, HEX., 8MM	1		
		26	94111-08000	WASHER, SPRING, 8MM	1		
		27	94201-20150	PIN, SPLIT, 2.0X15	1		
		28	94201-30250	PIN, SPLIT, 3.0X25	1		
		29	96140-63010-10	BEARING, RADIAL BALL, 6301	2		

1976.01.20

G13

G 14

Block No.

F-8

Rear Brake Panel

www.ustGP.com

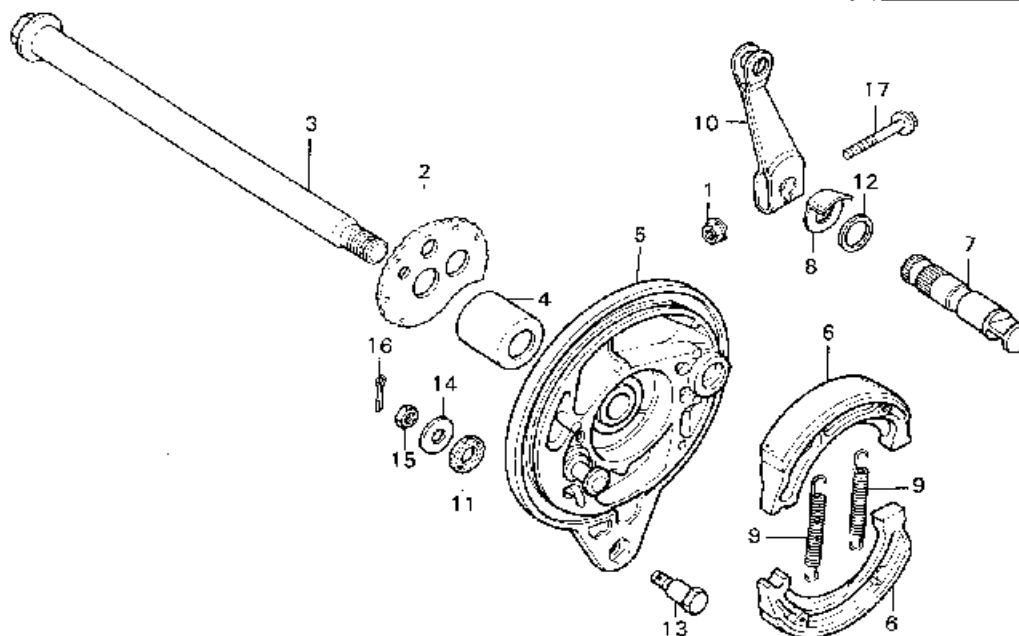

ARE5 33

Service Item	F.R.T.	Ref. No.	Part No.	Description	Reqd. No. TL125S	Serial No.	Area Code
REAR BRAKE PANEL and its related parts	0.5	1	18362-720-000	NUT, FLANGE, 6MM	1		
REAR WHEEL AXLE	0.3	2	40544-355-000	ADJUSTER, LEFT DRIVE CHAIN	1		
• R. CHAIN ADJUSTER		3	42301-401-680	AXLE, REAR WHEEL	1		
REAR BRAKE ARM and its related parts	0.1	4	42313-074-010	COLLAR, REAR BRAKE PANEL SIDE	1		
		5	43100-401-680	PANEL, REAR BRAKE	1		
		6	43120-365-671	SHOE COMP., BRAKE (NIPPON BRAKE LINING)	2		
			43120-365-672	SHOE COMP., BRAKE (ASAHI SEKIMEN)	2		
		7	43141-400-000	CAM, REAR BRAKE	1		
		8	43145-401-680	INDICATOR, REAR BRAKE	1		
		9	43151-110-000	SPRING, BRAKE SHOE	2		
		10	43411-401-680	ARM, REAR BRAKE	1		
		11	43434-286-000	RUBBER, STOPPER ARM CUSHION	1		
		12	45134-250-000	SEAL, BRAKE CAM DAST	1		
		13	90127-400-000	BOLT, REAR BRAKE STOPPER	1		
		14	90524-030-000	WASHER A, HANDLE HOLDER	1		
		15	94001-08000-0S	NUT, HEX., 8MM SETTING	1		
		16	94201-20150	PIN, SPLIT, 2.0X15	1		
		17	95700-06032	BOLT, FLANGE, 6X32	1		

1976.G1.20

G14

G 15

Block No.

F-9

Rear Wheel

www.justGP.com

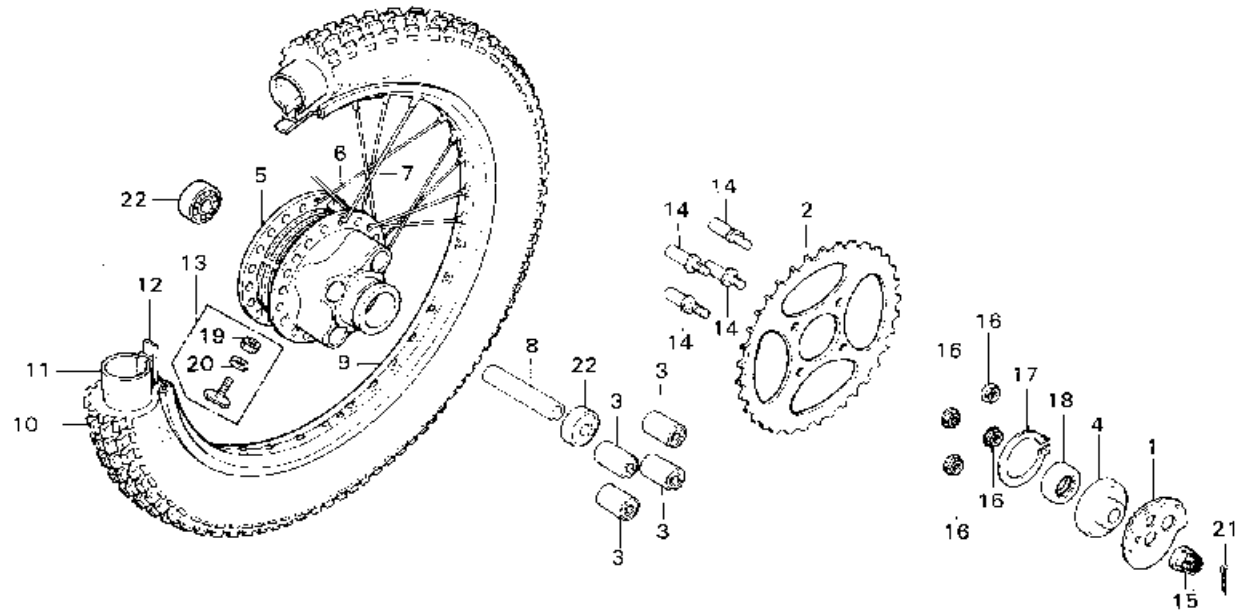

3355 39

Service Item	F.R.T.	Ref. No.	Part No.	Description	Reqd. No. TL125S	Serial No.	Area Code
REAR WHEEL HUB	3.5	1	40544-355-000	ADJUSTER, LEFT DRIVE CHAIN	1		
REAR WHEEL RIM	2.3	2	41201-382-670	SPROCKET, FINAL DRIVEN (52T)	1		
REAR WHEEL TIRE/TUBE/TIRE FLAP/ BEAD STOPPER	1.0		41201-355-810	SPROCKET, FINAL DRIVEN (60T)	(1)		
AXLE DISTANCE COLLAR/BALL BEARING	0.5	3	41241-307-010	BUSH, REAR WHEEL DAMPER	4		
• Add 0.1 at ball bearing		4	42304-107-000	COLLAR COMP., REAR WHEEL SIDE	1		
• REAR WHEEL DAMPER BUSH		5	42601-401-680	HUB, REAR WHEEL	1		
• One motorcycle 0.9		6	42606-355-000	SPOKE B; 9X169 (INSIDE)	18		
FINAL DRIVEN SPROCKET/FIXING BOLT	0.4	7	42607-355-620	SPOKE B; 9X168.5 (OUTSIDE)	18		
• 28 x 42 x 7 OIL SEAL		8	42620-107-010	COLLAR, REAR AXLE DISTANCE	1		
WHEEL SIDE COLLAR	0.3	9	42701-355-003	RIM, REAR WHEEL	1		
R. DRIVE CHAIN ADJUSTER	0.1	10	42711-329-671	TIRE, REAR (4.00-18 BS)	1		
• AXLE NUT			42711-329-672	TIRE, REAR (4.00-18 NITTO)	1		
		11	42712-300-003	TUBE, TIRE (3.75 4.00-18 BS)	1		
			42712-340-006	TUBE, TIRE (4.00-18 NITTO)	1		
		12	42713-300-003	FLAP, TIRE (2.15X18 BS)	1		
			42713-340-006	FLAP, TIRE (1.85X18 NITTO)	1		
		13	42715-355-006	STOPPER, REAR WHEEL TIRE BEAD 2.15B (NITTO)	2		
		14	90128-382-670	BOLT, DRIVEN SPROCKET FIXING	4		
		15	90305-401-680	NUT, AXLE, 14MM	1		
		16	90308-382-670	NUT, FLANGE, 10MM	4		
		17	90664-216-000	CIR CLIP, 58MM	1		
		18	91257-230-003	OIL SEAL, 28X42X7	1		
			91257-230-005	OIL SEAL, 28X42X7	1		
		19	94001-08000	NUT, HEX., 8MM	2		

1976.01.20

G15

H 1

Block No.

F-10

Fuel Tank

www.ustGP.com

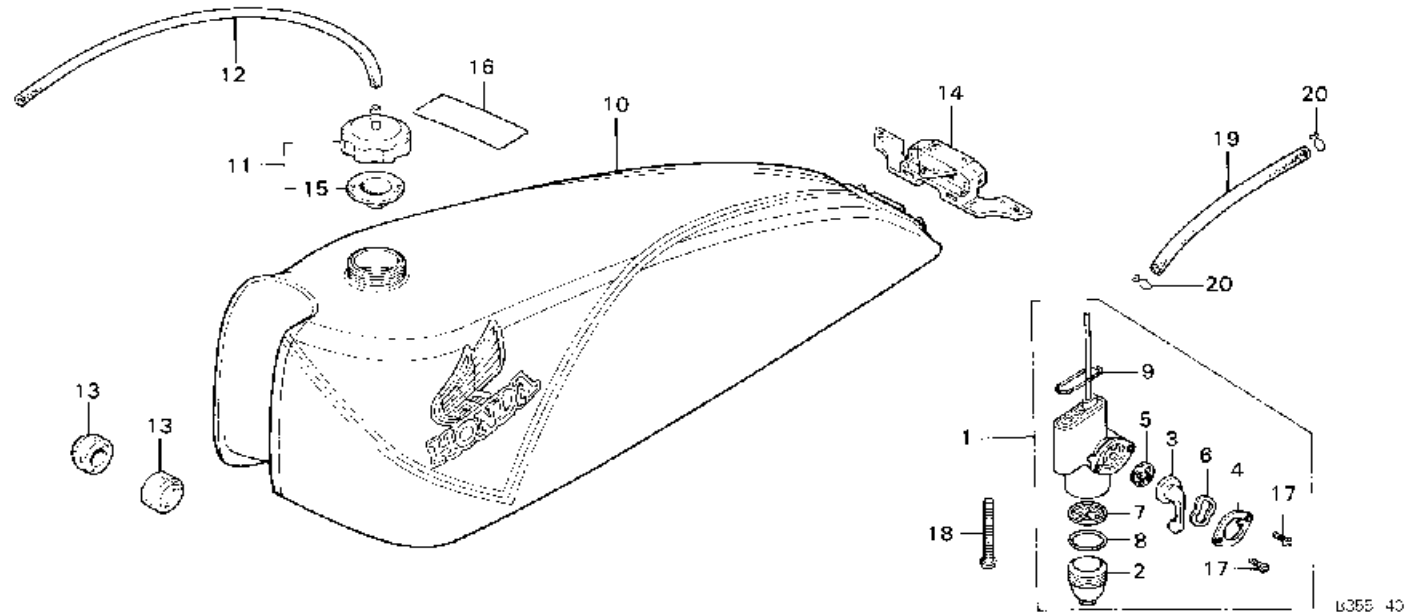

U365 40

Service Item	F.R.T.	Ref. No.	Part No.	Description	Reql. No. TL125S	Serial No.	Area Code
FUEL TANK ASSY.	0.3	1	16950-365-671	COCK ASSY.; FUEL	1		
FUEL COCK ASSY. and its related parts (Not included below parts)	0.2	2	16952-028-000	CUP; FUEL STRAINER	1		
		3	16953-389-670	LEVER; FUEL COCK	1		
		4	16954-389-670	PLATE; COCK LEVER SETTING	1		
FUEL STRAINER SCREEN/CUP • FUEL FILLER CAP	0.1	5	16955-028-004	GASKET; COCK LEVER	1		
		6	16956-028-004	SPRING; COCK LEVER	1		
		7	16957-028-000	SCREEN; FUEL STRAINER	1		
		8	16958-028-000	GASKET; FUEL STRAINER CUP	1		
		9	16997-273-000	O-RING; 23MM	1		
		10	17500-355-700ZA	TANK ASSY.; FUEL 4YR-26*	1		
		11	17510-355-000	CAP ASSY.; FUEL TANK	1		
		12	17520-357-000	TUBE; FUEL CAP BREATHER	1		
		13	17611-331-000	CUSHION; FUEL TANK FRONT	2		
		14	17613-355-620	REAR CUSHION; FUEL TANK	1		
		15	17624-355-000	GASKET; FUEL FILLER CAP	1		
		16	87560-375-680B	MARK; DRIVE CAUTION	1		
		17	93500-03006-0A	SCREW; PAN; 3X6	2		
		18	93500-06040	SCREW; PAN; 6X40	1		
		19	95001-45100-40	TUBE; FUEL; 4.5X100	1		
		20	95002-02080	CLIP; TUBE; 88	2		

1976.01.20

H1

H 2

Block No.

F-11

Seat - Side Cover

www.justGP.com

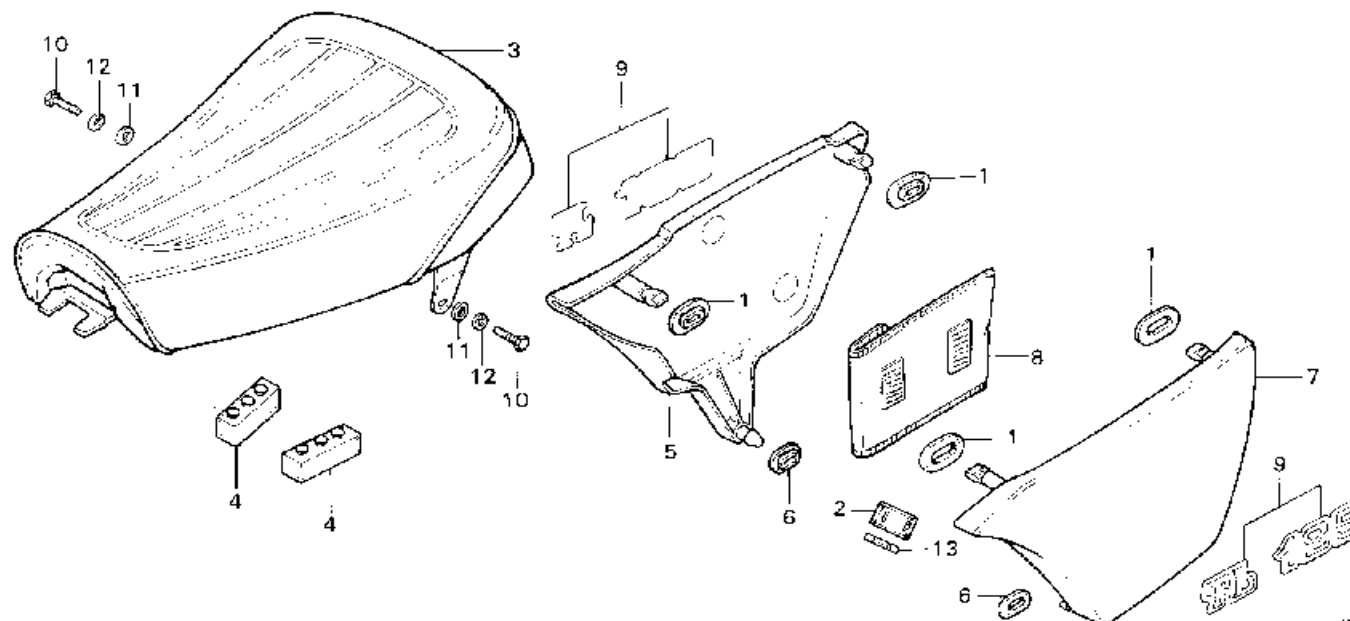

B3-5-11

Service Item	F.R.T.	Ref. No.	Part No.	Description	Reqd. No. (L125S)	Serial No.	Area Code
SEAT COMP. and its related parts	0.1	1	17247-303-300	GROMMET A, AIR CLEANER CASE	4		
SIDE COVER	0.1	2	78205-115-000	CASE, FUSE	1		
+ One or all		3	77100-355-620	SEAT COMP.	1		
		4	77205-286-000	RUBBER B, SEAT SETTING	2		
		5	83540-355-620ZA	COVER, RIGHT SIDE *NH-44H-S*	1		
		6	83551-300-000	GROMMET, AIR CLEANER CASE	2		
		7	83630-355-620ZA	COVER, LEFT SIDE *NH-44H-S*	1		
		8	83642-355-000	BAG, OWNERS MANUAL	1		
		9	87128-355-710ZA	EMBLEM, SIDE COVER *YR-26*	2		
		10	92000-08020-0A	BOLT, HEX., 8X20	2		
		11	94101-08000	WASHER, PLAIN, 8MM	2		
		12	94111-08000	WASHER, SPRING, 8MM	2		
		13	98200-11000	FUSE, 10A	1		

1976.01.2C

H2

H 3

Block No.

F-12

Air Cleaner • Battery

www.ustGP.com

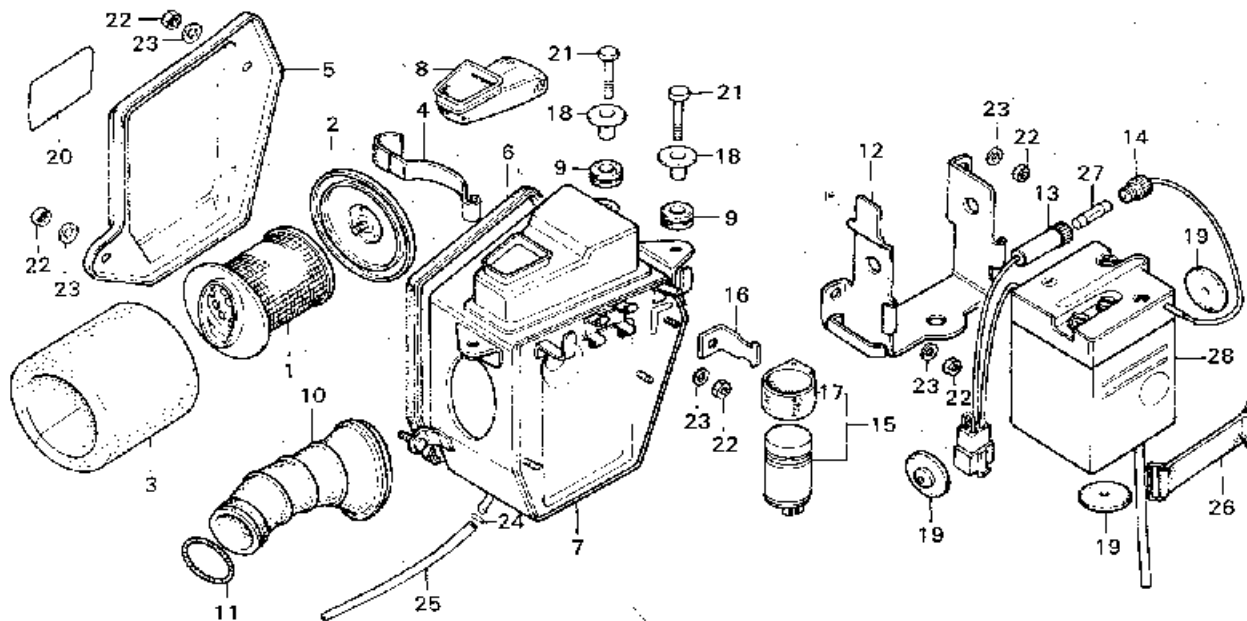

R356-47

Service Item	F.R.T.	Ref. No.	Part No.	Description	Reqd. No. TL1255	Serial No.	Area Code
AIR CLEANER CASE	0.9	1	17211-383-670	TRAP COMP., FLAME	1		
CONNECTING TUBE	0.4	2	17212-385-000	CAP., ELEMENT HOLDER	1		
BATTERY TRAY	0.2	3	17213-383-670	ELEMENT, AIR CLEANER	1		
BATTERY	0.1	4	17217-385-000	SPRING, ELEMENT SET	1		
• WINKER RELAY		5	17220-401-680	COVER, AIR CLEANER	1		
• AIR CLEANER ELEMENT and its related parts		6	17226-382-670	PACKING, AIR CLEANER CASE	1		
		7	17230-401-680	CASE, AIR CLEANER	1		
		8	17241-401-680	INNER, AIR CLEANER DUCT	1		
		9	17245-107-010	RUBBER, AIR CLEANER CASE MOUNT	3		
		10	17253-401-680	TUBE, CONNECTING	1		
		11	17255-028-000	BAND A, CLEANER CONNECTING TUBE	1		
		12	31530-365-670	TRAY, BATTERY	1		
		13	32106-041-008	CONNECTOR A, FUSE (YUASA)	1		
		14	32112-041-008	CONNECTOR B, FUSE (YUASA)	1		
		15	38300-329-000	RELAY ASSY., WINKER	1		U
			38300-386-008	RELAY ASSY., WINKER	1		F, E, D, F
		16	38301-365-670	STAY, WINKER RELAY	1		
		17	38306-292-000	SUSPENSION, WINKER RELAY	1		
		18	61104-357-000	COLLAR, FRONT FENDER	3		
		19	83618-323-000	RUBBER, BATTERY BOX	3		
		20	87508-120-000	LABEL, AIR CLEANER CAUTION	1		
		21	92000-06025	BOLT, HEX., 6X25	3		
		22	94001-06000	NUT, HEX., 6MM	5		
		23	94101-06000	WASHER, PLAIN, 6MM	5		
		24	95002-30000	CLIP, TUBE, C6	1		

1976.01.20

H3

H 4

Block No.

F-12

Air Cleaner - Battery

www.mustGP.com

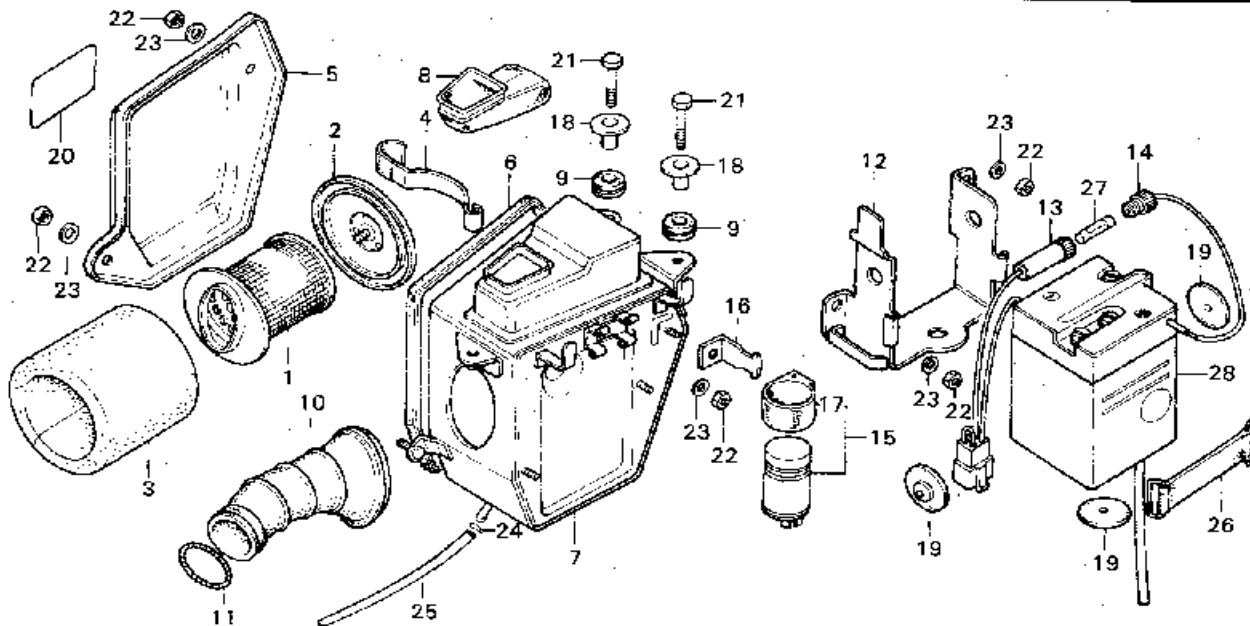

3055-42

Service Item	F.R.T.	Ref. No.	Part No.	Description	Reqd. No. TL125S	Serial No.	Area Code
		25	95003-08015-10	TUBE, VINYL	1		
		26	95012-12000	BAND B1, BATTERY	1		
		27	98200-11000	FUSE, 10A	1		
		28	98202-66130	BATTERY ASSY. 16N41	1		

1976.01.20

H4



Block No.

F-13

Exhaust Muffler

www.ustGP.com

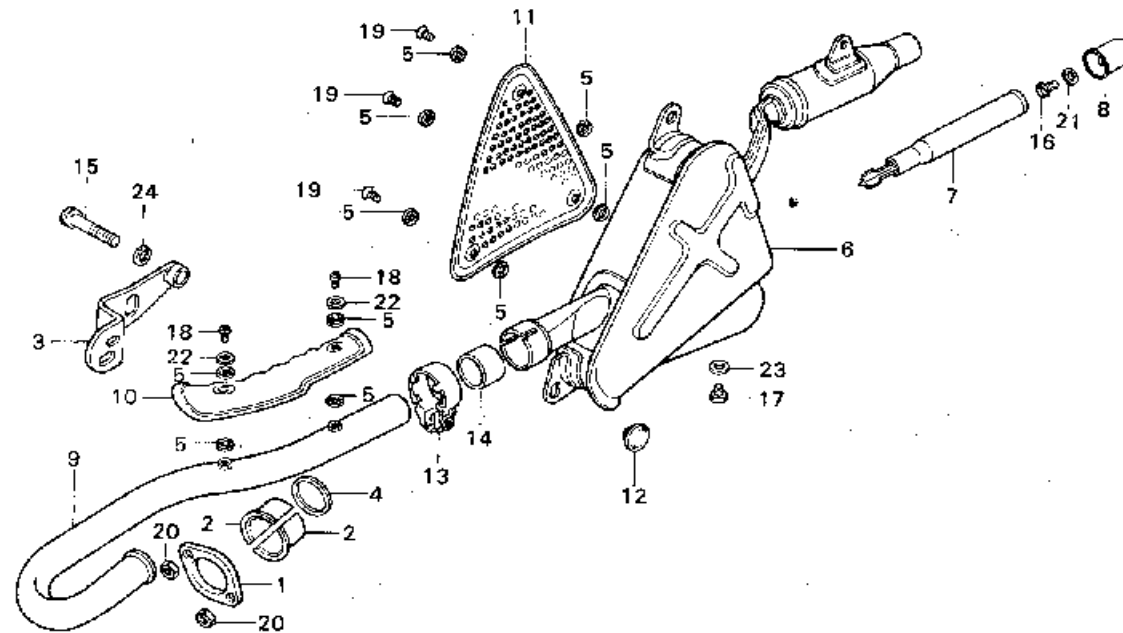

B395-43

Service Item	F.R.T.	Ref. No.	Part No.	Description	Reqd. No. TL125S	Serial No.	Area Code
ARRESTER MUFFLER	0.3	1	18231-355-000	JOINT, EXHAUST PIPE	1		
EXHAUST PIPE and its related parts	0.2	2	18233-107-000	COLLAR, EXHAUST PIPE JOINT	2		
EXHAUST PIPE PROTECTOR/ MUFFLER PROTECTOR	0.1	3	18284-355-000B	STAY, EXHAUST PIPE	1		
		4	18291-216-000	GASKET, EXHAUST PIPE	1		
		5	18292-329-000	PACKING, PROTECTOR	10		
		6	18300-355-620	MUFFLER COMP., ARRESTER	1		
		7	18311-355-620	PIPE, DIFFUSER	1		
		8	18315-355-620	COVER, PIPE END	1		
		9	18320-355-000	PIPE, EXHAUST	1		
		10	18325-355-000	PROTECTOR, EXHAUST PIPE	1		
		11	18360-355-000	PROTECTOR, MUFFLER	1		
		12	18365-355-670	RUBBER, MUFFLER MOUNT	1		
		13	18371-355-710	BAND, MUFFLER	1		
		14	18391-313-000	GASKET, MUFFLER	1		
		15	90116-355-000	BOLT, SOCKET	1		
		16	92000-05008-4J	BOLT, HEX., 5X8	1		
		17	92000-06008	BOLT, HEX., 6X8	1		
		18	93500-05006-DG	SCREW, PAN, 5X6	2		
		19	93700-05006-DG	SCREW, OVAL, 5X6	3		
		20	94001-06000	NUT, HEX., 6MM	2		
		21	94101-05000	WASHER, PLAIN, 5MM	1		
		22	94101-05700	WASHER, PLAIN, 5MM	2		
		23	94101-06000	WASHER, PLAIN, 6MM	1		
		24	94111-08000	WASHER, SPRING, 8MM	1		

1976.01.20

H5

H 6

Block No.

F-14

**Pedal · Kick Arm ·
Stand · Step**

www.custGP.com

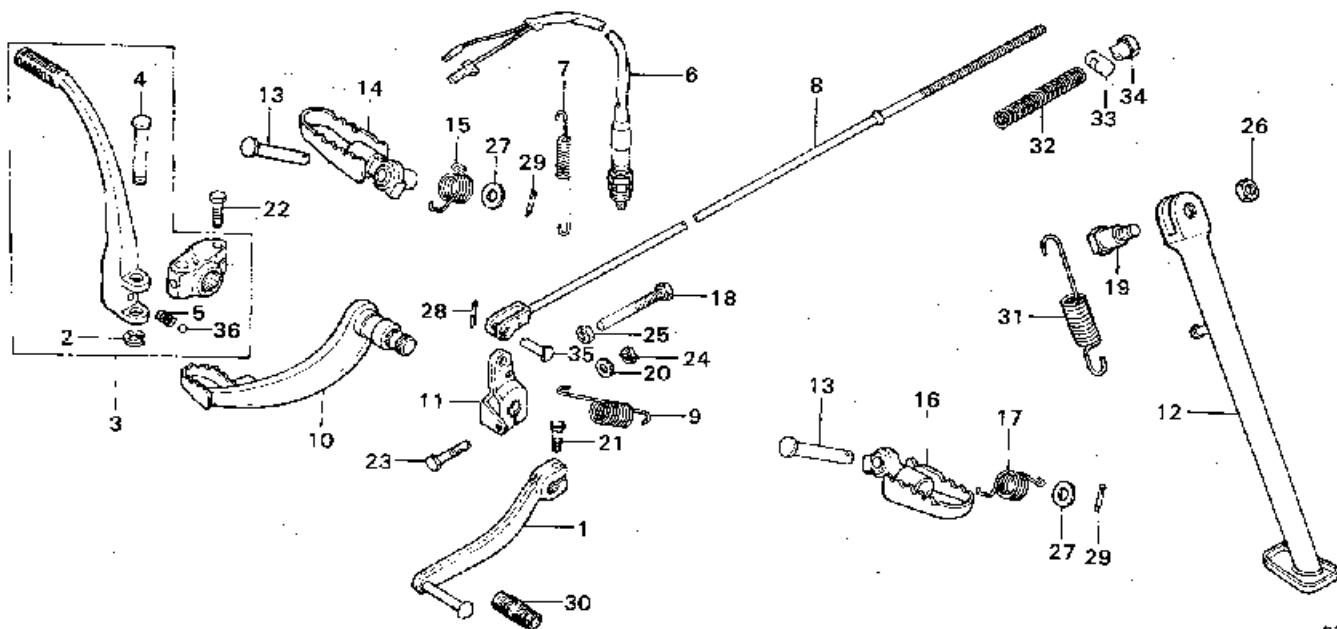

B355-44

Service Item	F.R.T.	Ref. No.	Part No.	Description	Reqd. No. TL125S	Serial No.	Area Code
SIDE STAND BAR	0.2	1	24700-313-010	PEDAL, GEAR CHANGE	1		
• REAR BRAKE PEDAL SHAFT/ MIDDLE ARM		2	28293-124-000	CLIP, KICK STARTER ARM	1		
• REAR STOP SWITCH ASSY.		3	28300-365-671	ARM ASSY., KICK STARTER	1		
GEAR CHANGE PEDAL/RUBBER	0.1	4	28321-355-003	PIN, KICK STARTER (MURAMATSU)	1		
• BRAKE ROD		5	28333-124-000	SPRING, KICK STARTER STOPPER	1		
• KICK STARTER ARM and its related parts		6	35350-355-601	SWITCH ASSY., REAR STOP	1		
STEP	0.1	7	35357-083-000	SPRING, STOP SWITCH	1		
• One or all		8	43451-355-620	ROD, REAR BRAKE	1		
		9	46514-355-000	SPRING, BRAKE PEDAL	1		
		10	46515-355-000B	SHAFT COMP., REAR BRAKE PEDAL	1		
		11	46516-355-000	ARM, MIDDLE	1		
		12	50530-355-620ZA	BAR, SIDE STAND *NH-1*	1		
		13	50603-033-000	PIN, STEP BAR JOINT	2		
		14	50616-355-000	STEP COMP., RIGHT	1		
		15	50617-329-000	SPRING, RIGHT STEP RETURN	1		
		16	50642-355-000	STEP COMP., LEFT	1		
		17	50644-329-000	SPRING, LEFT STEP RETURN	1		
		18	90100-355-000	BOLT, HEX., 8x57	1		
		19	90108-283-000	SCREW, SIDE STAND PIVOT	1		
		20	90525-001-000	WASHER, REAR BRAKE ARM	1		
		21	92000-06020	BOLT, HEX., 6X20	1		
		22	92000-06022	BOLT, HEX., 6X22	1		
		23	92000-06032	BOLT, HEX., 6X32	1		
		24	94001-06000	NUT, HEX., 6MM	1		
		25	94001-08000-0S	NUT, HEX., 8MM	1		

1976.01.20

H6

H 7

Block No.

F-14

**Pedal - Kick Arm -
Stand - Step**

www.mustGP.com

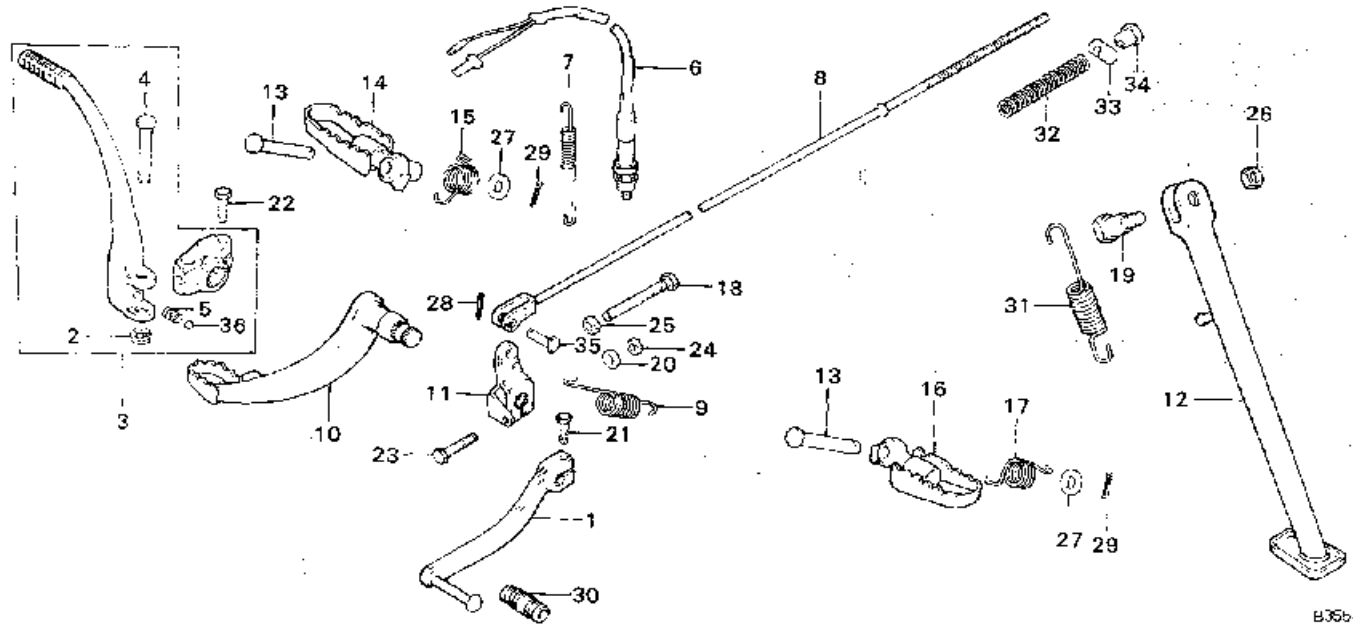

B35b-44

Service Item	F.R.T.	Ref. No.	Part No.	Description	Reqd. No. TL125S	Serial No.	Area Code
		26	94002-10060-05	NUT, HEX., 10MM	1		
		27	94101-08000	WASHER, PLAIN, 8MM	2		
		28	94201-16120	PIN, SPLIT, 1.6X12	1		
		29	94201-16150	PIN, SPLIT, 1.6X15	2		
		30	95011-40000	RUBBER, GEAR CHANGE PEDAL	1		
		31	95014-72401	SPRING D, SIDE STAND	1		
		32	95014-73100	SPRING A, BRAKE ROD	1		
		33	95015-32001	JOINT, BRAKE ARM	1		
		34	95015-42000	NUT B, ADJUST	1		
		35	95015-52000	PIN B, JOINT	1		
		36	96211-08000	BALL, STEEL, #8	1		

1976.01.20

H7



Block No.

F-16

Rear Cushion

www.CustGP.com

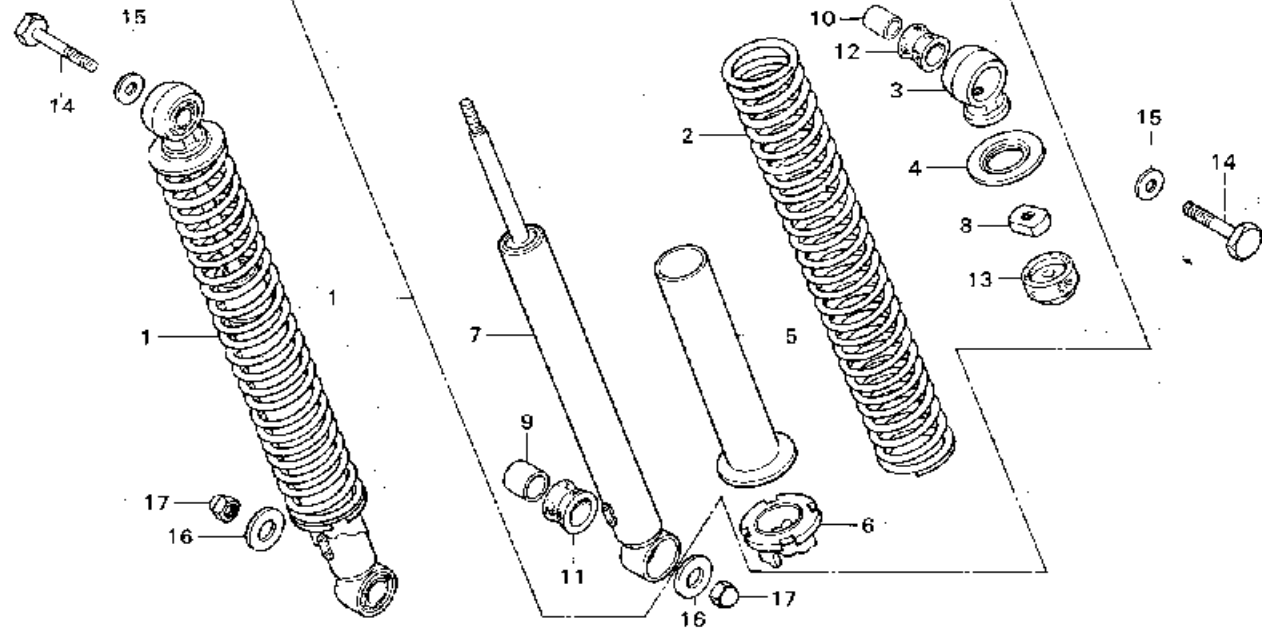

B355 46

Service Item	F.R.T.	Ref. No.	Part No.	Description	Reqd. No. TL125S	Serial No.	Area Code
REAR CUSHION ASSY.	0.1	1	52400-355-700	CUSHION ASSY., REAR	2		
REAR CUSHION SPRING and its related parts	0.3	2	52401-355-700	SPRING, REAR CUSHION	2		
		3	52403-331-003	JOINT, UPPER	2		
		4	52405-355-000	STOPPER, SPRING SEAT	2		
		5	52406-355-000	GUIDE, REAR CUSHION SPRING	2		
		6	52422-455-000	ADJUSTER, REAR CUSHION SPRING	2		
		7	52430-355-010	CUSHION COMP., REAR	2		
		8	52482-331-003	NUT, LOCK, 9MM	2		
		9	52486-056-000	COLLAR, REAR CUSHION RUBBER	2		
		10	52486-074-000	COLLAR, REAR CUSHION RUBBER BUSH BUSH	2		
		11	52488-331-003	RUBBER B, JOINT	2		
		12	52489-331-003	RUBBER A, JOINT	2		
		13	52517-331-003	RUBBER, REAR CUSHION STOPPER	2		
		14	90122-355-000	BOLT, REAR CUSHION	2		
		15	90524-030-000	WASHER A, HANDLE HOLDER SETTING	2		
		16	90527-230-000	WASHER, PLAIN, 10.3MM	2		
		17	94021-10020-0S	NUT, CAP, 10MM	2		

1976.01.20

H9

H 10

Block No.

F-17

Rear Fender

www.ustGP.com

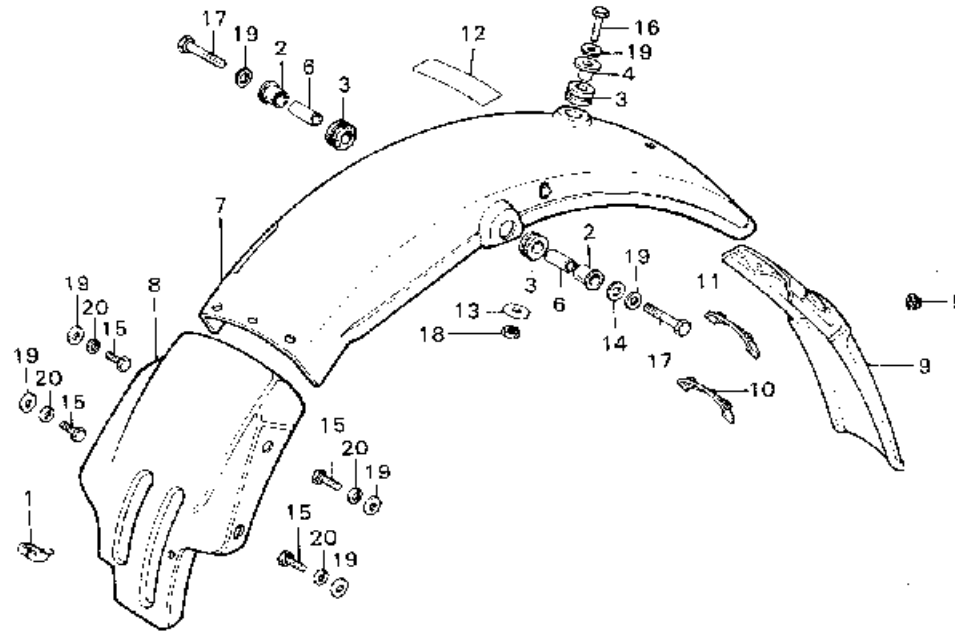

U355 47

Service Item	F.R.T.	Ref. No.	Part No.	Description	Reqd. No. TL125S	Serial No.	Area Code
REAR FENDER COMP. (ED)	0.6	1	32985-107-780	GROMMET, WIRE CORD	1		
REAR FENDER COMP.	0.5	2	33719-077-671	PACKING B, TAIL LIGHT BASE	2		
REAR FENDER B.	0.3	3	61103-357-000	RUBBER, FRONT FENDER MOUNT	3		
REAR FENDER C. (ED)	0.1	4	61104-357-000	COLLAR, FRONT FENDER	1		
		5	66214-538-910	PLUG, SWITCH HOLE	1		ED
		6	77209-385-000	COLLAR, SETTING RUBBER	2		
		7	80100-382-670	FENDER COMP., REAR	1		
		8	80102-355-620ZA	FENDER B, REAR *NH-1*	1		
		9	80103-382-610	FENDER C, REAR	1		ED
		10	80202-386-000	PATCH B, FENDER C	1		ED
		11	80203-382-610	PATCH A, REAR FENDER C	1		ED
		12	87505-355-620	MARK, TIRE CAUTION	1		
		13	90525-030-000	WASHER B, HANDLE HOLDER	1		
				SETTING			
		14	90545-323-700	WASHER, 6.5X18	1		
		15	92000-06012	BOLT, HEX., 6X12	4		
		16	92000-06025	BOLT, HEX., 6X25	1		
		17	92000-06032	BOLT, HEX., 6X32	2		
		18	94001-06000	NUT, HEX., 6MM	1		
		19	94101-06000	WASHER, PLAIN, 8MM	7		
		20	94111-06000	WASHER, SPRING, 6MM	4		

1976.01.20

HIC

H 11

Block No.

F-18

Winker

www.mustGP.com

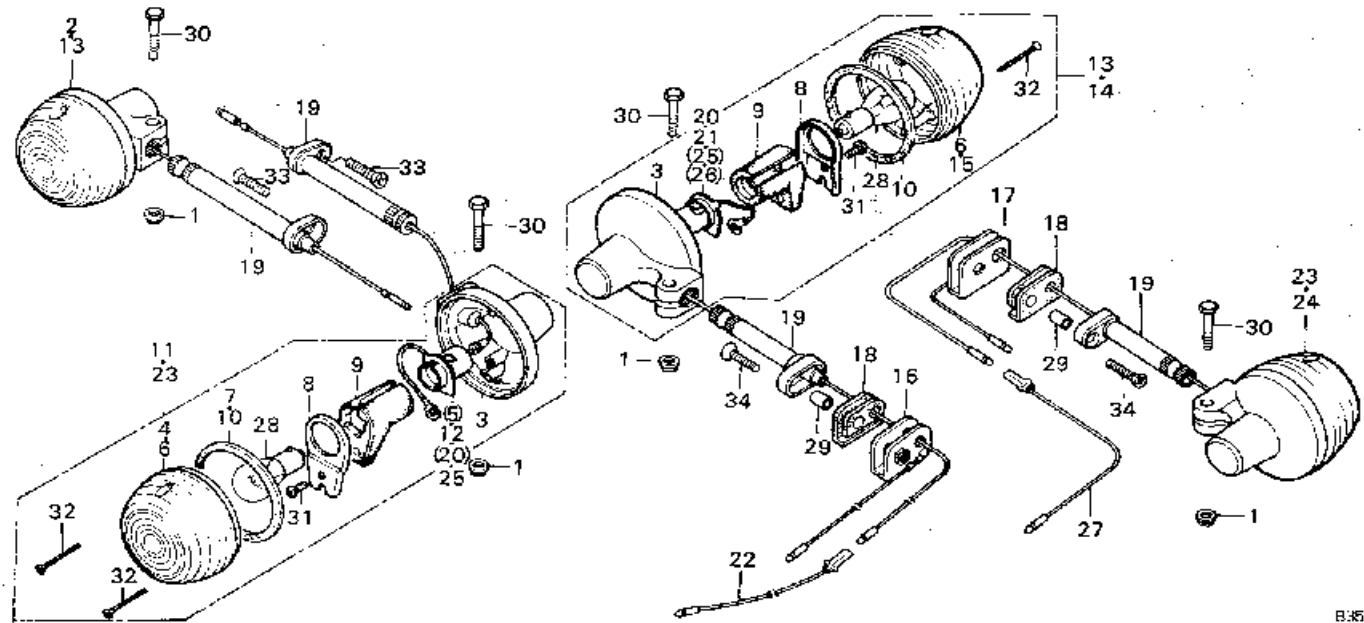

B:355-1B

Service Item	F.R.T.	Ref. No.	Part No.	Description	Reqd. No. TL125S	Serial No.	Area Code
FRONT WINKER SOCKET/BASE	0.3	1	18362-720-000	NUT, FLANGE, 6MM	4		
FRONT WINKER ASSY.	0.2	2	33400-336-730	WINKER ASSY., RIGHT FRONT	1		E,ED,F
• WINKER SET BOLT		3	33401-292-003	BASE, WINKER	4		
REAR WINKER ASSY.	0.2	4	33402-268-671	LCNS, FRONT WINKER	2		E,ED,F
• SOCKET/BASE		5	33402-336-000	SOCKET, RIGHT FRONT WINKER	1		E,ED,F
• WINKER STAY and its related parts		6	33404-268-671	LENS, FRONT WINKER	4		U
WINKER LENS/BULB	0.1	7	33406-268-671	PACKING, WINKER LENS	2		E,ED,F
		8	33407-284-003	HOLDER, WINKER SOCKET	4		
		9	33408-341-701	RUBBER, WINKER CUSHION	4		
		10	33443-268-671	PACKING, FRONT WINKER LENS	2		F,ED,F
					4		U
		11	33450-336-730	WINKER ASSY., LEFT FRONT	1		E,ED,F
		12	33460-361-003	SOCKET COMP., LEFT WINKER	1		E,ED,F
		13	33600-304-970	WINKER ASSY., RIGHT REAR	2		U
		14	33600-336-730	WINKER ASSY., RIGHT REAR	1		E,ED,F
		15	33602-323-631	LENS, REAR WINKER	2		E,ED,F
		16	33604-323-670	STOPPER, RIGHT REAR WINKER	1		
		17	33605-323-670	STOPPER, LEFT REAR WINKER	1		
		18	33606-074-010	RUBBER, REAR WINKER MOUNT	2		
		19	33607-324-670	STAY, RIGHT REAR WINKER	4		
		20	33610-304-670	SOCKET, RIGHT REAR WINKER	2		U
		21	33610-306-670	SOCKET COMP., RIGHT REAR WINKER	1		E,ED,F
		22	33615-107-670	CORD, RIGHT REAR WINKER SUB	1		
		23	33650-304-970	WINKER ASSY., LEFT REAR	2		U
		24	33650-336-730	WINKER ASSY., LEFT REAR	1		E,ED,F

1976.01.20

H11

H 12

Block No.

F-18

Winker

www.CustGP.com

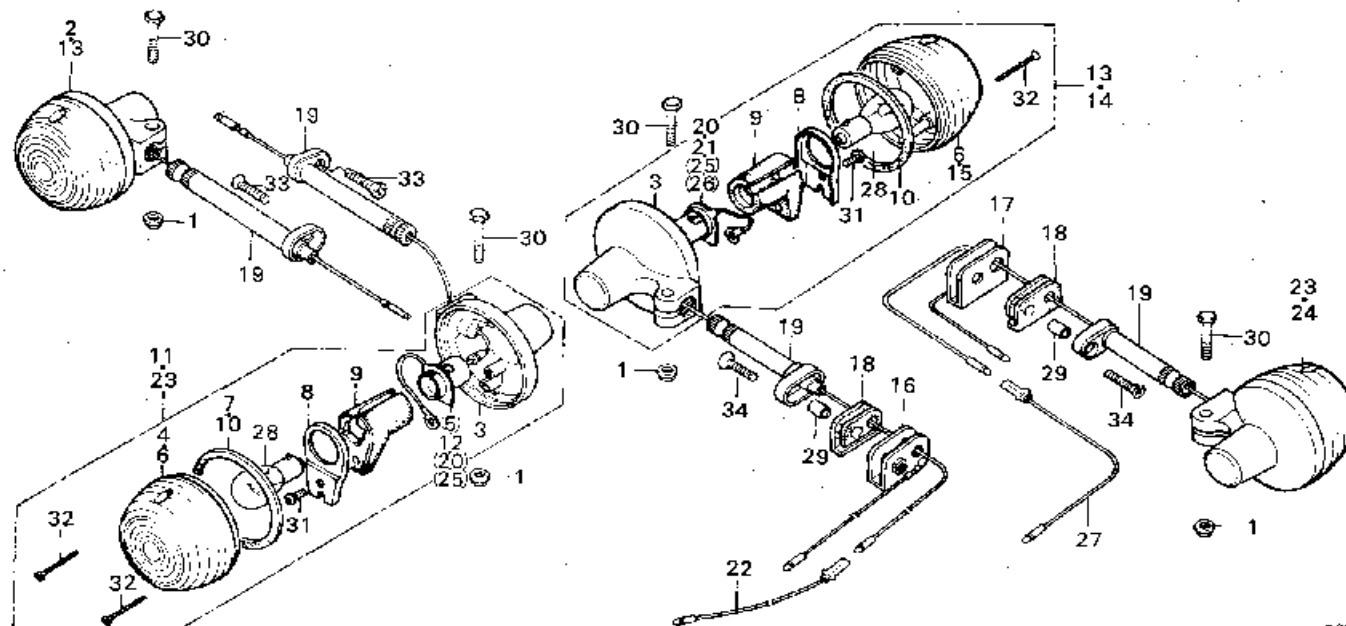

B355-48

Service Item	F.R.T.	Ref. No.	Part No.	Description	Reqd. No. TL125S	Serial No.	Area Code
		25	33660-504-670	SOCKET, LEFT REAR WINKER	2		U
		26	33660-506-670	SOCKET, LEFT REAR WINKER	1		E, ED, F
		27	33666-304-650	CORD, LEFT REAR WINKER SUB	1		U
		28	34905-212-000	BULB, WINKER (6V 10W)	4		E, ED, F
				BULB, WINKER (LOCAL PROCUREMENT)	1		
		29	80108-061-000	COLLAR A, REAR FENDER	2		
		30	92000-06028	BOLT, HEX., 6X28	4		
		31	93500-05009-0A	SCREW, PAN, 5X8	4		
		32	93700-03025-0B	SCREW, OVAL, 3X25	8		
		33	93700-06016	SCREW, OVAL, 6X16	2		
		34	93700-06025	SCREW, OVAL, 6X25	2		

1976.01.20

H12

H 13

Block No.

F-19

Tail Light (E,ED,F)

www.mustGP.com

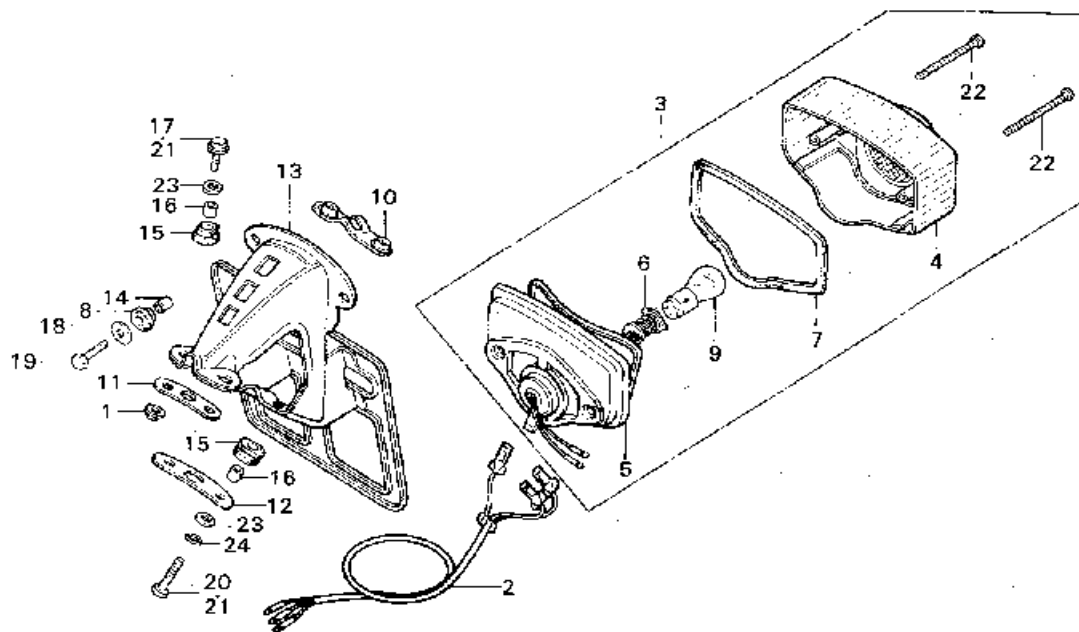

6306-40

Service Item	F.R.T.	Ref. No.	Part No.	Description	Reqd. No. TL125S	Serial No.	Area Code
NUMBER PLATE BRACKET	0.3	1	18362-720-000	NUT, FLANGE, 6MM	2		E,ED,F
TAILLIGHT UNIT/BASE and those related parts	0.2	2	32111-365-670	CORD, TAIL SUB	1		E,ED,F
• SUB CORD		3	33701-098-631	LIGHT UNIT, TAIL	1		E,ED,F
TAILLIGHT LENS/BULB	0.1	4	33702-323-603	LENS, TAIL LIGHT	1		E,ED,F
		5	33703-077-671	BASE, TAIL LIGHT	1		E,ED,F
		6	33708-077-671	CORD COMP., TAIL LIGHT	1		E,FO,F
		7	33709-077-671	PACKING, TAIL LIGHT LENS	1		E,ED,F
		8	33719-077-671	PACKING B, TAIL LIGHT BASE	2		E,ED,F
		9	34906-098-931	BULB, STOP & TAIL LIGHT (6V21/5W)	1		E,ED,F
		10	80109-340-000	PLATE A, NUMBER BRACKET SET	1		E,ED,F
		11	80109-382-670	PLATE A, BRACKET SET	1		E,ED,F
		12	80110-312-000	PLATE B, NUMBER BRACKET SET	1		E,ED,F
		13	84701-329-600	BRACKET, NUMBER PLATE	1		E,ED,F
		14	84706-342-000	COLLAR, TAIL LIGHT UNIT	2		E,ED,F
		15	84905-333-000	RUBBER, CUSHION	4		E,ED,F
		16	84906-118-000	COLLAR, NUMBER BRACKET	4		E,ED,F
		17	90122-369-000	BOLT, FRANGE, 6X25	2		E,F
		18	90581-342-000	WASHER, 20MM	2		E,ED,F
		19	92000-05020-0A	BOLT, HEX., 5X20	2		E,ED,F
		20	92000-06028	BOLT, HEX., 6X28	2		E,F
		21	92000-06035	BOLT, HEX., 6X35	4		ED
		22	93500-04050-4J	SCREW, PAN, 4X50	2		E,ED,F
		23	94101-06000	WASHER, PLAIN, 6MM	2		E,F
					4		ED
		24	94111-06000	WASHER, SPRING, 6MM	2		ED

1976.01.20

H13

H 14

Block No.
F-19-1
 Tail Light (U)

www.CustGP.com

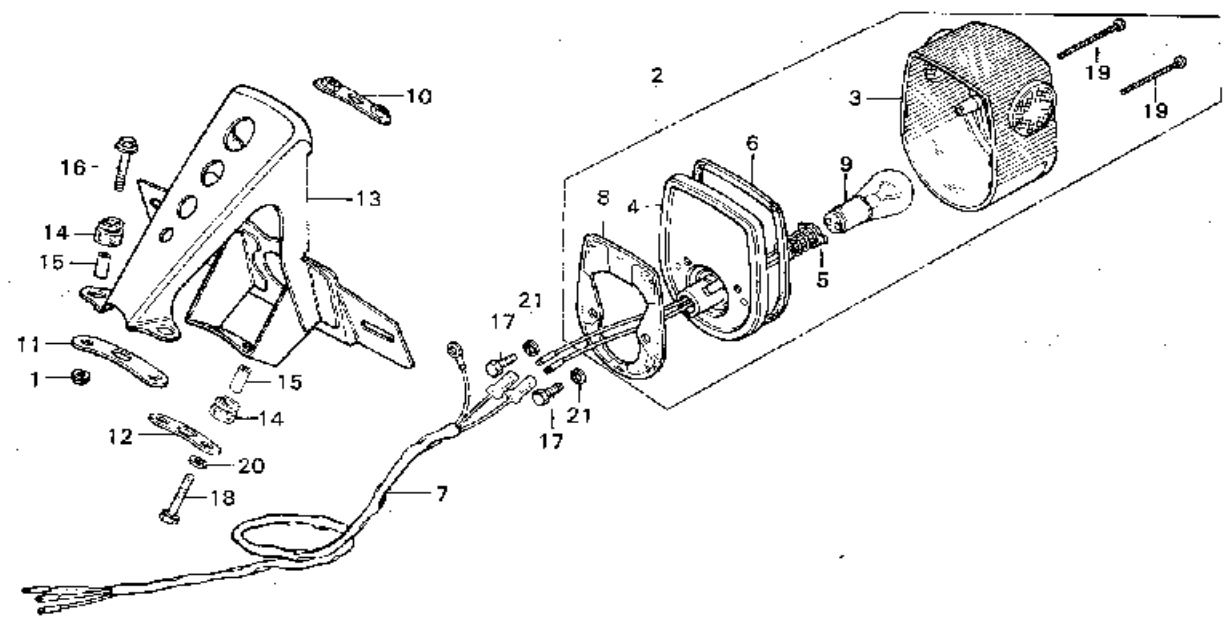

B30b-b0

Service Item	F.R.T.	Ref. No.	Part No.	Description	Reqd. No. TL125S	Serial No.	Area Code
NUMBER PLATE BRACKET/TAILLIGHT UNIT/BASE and those related parts	0.3	1	18362-720-000	NUT, FLANGE, 6MM	2		U
		2	33701-331-000	LIGHT UNIT, TAIL	1		U
TAILLIGHT SUB CORD	0.2	3	33702-313-000	LENS, TAIL LIGHT	1		U
TAILLIGHT LENS/BULB	0.1	4	33703-098-003	BASE, TAIL LIGHT	1		U
		5	33708-098-000	CORD COMP., TAIL LIGHT	1		U
		6	33709-074-671	PACKING, TAIL LIGHT LENS	1		U
		7	33711-361-000	CORD, TAIL LIGHT SUB	1		U
		8	33719-074-670	PACKING, TAIL LIGHT BASE	1		U
		9	34906-030-013	BULB, STOP & TAIL LIGHT (6V 10/3W)	1		U
		10	80109-340-000	PLATE A, NUMBER BRACKET SET	1		U
		11	80109-382-670	PLATE A, BRACKET SET	1		U
		12	80110-312-000	PLATE B, NUMBER BRACKET SET	1		U
		13	84701-382-000	BRACKET, NUMBER PLATE	1		U
		14	84905-333-000	RUBBER, CUSHION	4		U
		15	84906-118-000	COLLAR, NUMBER BRACKET	4		U
		16	90122-369-000	BOLT, FLANGE, 6X25	2		U
		17	92000-05D12-0A	BOLT, HEX., 5X12	2		U
		18	92000-06028	BOLT, HEX., 6X28	2		U
		19	93500-04050-0B	SCREW, PAN, 4X50	2		U
		20	94101-06000	WASHER, PLAIN, 6MM	2		U
		21	94111-05000	WASHER, SPRING, 5MM	2		U

1976.01.20

H14

H 15

Block No.

F-20

**Wire Harness •
Ignition Coil**

www.justGP.com

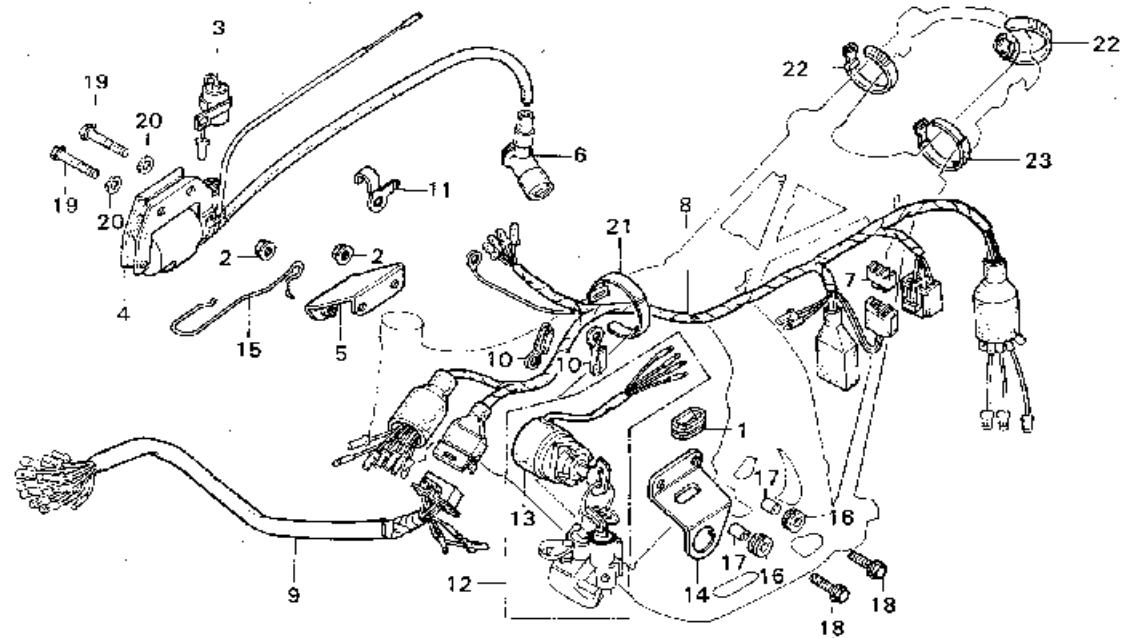

3355-51

Service Item	F.R.T.	Ref. No.	Part No.	Description	Reqd. No. 1L125S	Serial No.	Area Code
WIRE HARNESS	0.8	1	17247-240-000	GROMMET #; AIR CLEANER CASE	1		
FRONT HARNESS	0.4	2	18362-720-000	NUT; FLANGE; 6MM	2		
• KEY SET		3	3C25C-052-156	CONDENSER ASSY.	1		
MAIN SWITCH BRACKET	0.3	4	30500-355-003	COIL ASSY.; IGNITION (TOYO)	1		
IGNITION COIL/CONDENSER	0.2	5	3C530-355-000	BRACKET; IGNITION COIL	1		
• COMBINATION SWITCH		6	30800-918-870	CAP ASSY.; NOISE SUPPRESSOR	1		U
• SILICON RECTIFIER		7	30700-243-618	CAP ASSY.; NOISE SUPPRESSOR	1		E,ED,F
		7	31700-124-003	RECTIFIER ASSY.; SILICON (STANLEY)	1		
		8	32100-401-680	HARNESS; WIRE	1		
		9	32150-401-680	HARNESS ASSY; FRONT	1		
		10	32173-369-000	CLIP C; WIRE HARNESS	2		
		11	32906-355-000	CLIP; HIGH TENSION CORD	1		
		12	35010-382-600	KEY SET	1		
		13	35100-382-671	SWITCH ASSY.; COMBINATION	1		
		14	5C375-331-000	BRACKET; MAIN SWITCH	1		
		15	50721-382-670	GUIDE; CLUTCH CABLE	1		
		16	84705-292-000	RUBBER; NUMBER BRACKET CUSHION	2		
		17	84706-286-000	COLLAR; NUMBER BRACKET SET	2		
		18	90122-369-000	BOLT; FRANGE; 6X25	2		
		19	92000-06025	BOLT; HEX.; 6X25	2		
		20	94101-06000	WASHER, PLAIN, 8MM	2		
		21	95014-61300	BAND #3; WIRE	1		
		22	95014-62100	BAND #1; WIRE	2		
		23	95014-62200	BAND #2; WIRE	1		

1976.01.20

H15

H 16

Block No.

F-21

Frame Body • Tool

www.ustGP.com

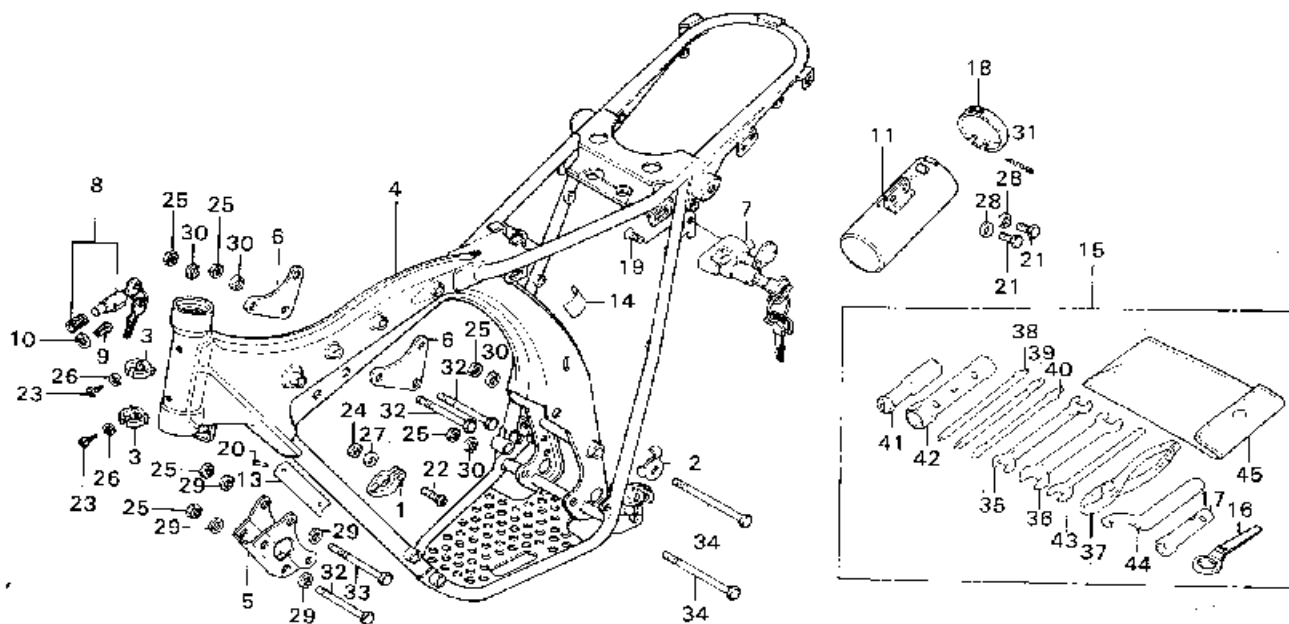

0365-52

Service Item	F.R.T.	Ref. No.	Part No.	Description	Reqd. No. TL125S	Serial No.	Area Code
R/L. ENGINE UPPER HANGER PLATE	0.2	1	22878-355-000	CLAMPER, CLUTCH CABLE	1		
FRONT ENGINE HANGER PLATE	0.1	2	32907-331-000	CLIP, A.C. GENERATOR COHD	1		
• TOOL BOX		3	32985-355-000	CLIP, WIRE CORDE	2		
		4	50100-355-620ZA	BODY COMP., FRAME *NH-1*	1		
		5	50351-355-000B	PLATE, FRONT ENGINE HANGER	1		
		6	50353-107-000	PLATE, RIGHT ENGINE UPPER HANGER	2		
		7	50710-382-671	HOLDER ASSY., HELMET	1		
		8	53600-051-000	LOCK COMP., HANDLE	1		
		9	53603-051-000	RIVET, 4MM	1		
		10	53604-098-940	WASHER, 4.5MM	1		
		11	83501-355-620	BOX COMP., TOOL	1		
		13	87151-355-730	PLATE, COMPLIANCE	1		U
			87501-355-620	PLATE, REGISTERD NUMBER	1		E, ED, F
		14	87506-382-670	MARK, BATTERY CAUTION	1		
		15	89010-355-700	TOOL SET	1		
		16	89214-355-710	WRENCH, EYE, 24MM	1		
		17	89217-355-000	BOX WRENCH, 10MM	1		
		18	89502-918-000B	CAP, TOOL BOX	1		
		19	90164-028-000	SCREW, U LOCK FLAT, 6X12	2		
		20	90841-001-000	SCREW, RIVET, 1.5X5	2		
		21	92000-06012	BOLT, HEX., 6X12	2		
		22	93500-05020-1A	SCREW, PAN, 5X20	1		
		23	93901-14010	SCREW, TAPPING, 4X6	2		
		24	94001-05000-05	NUT, HEX., 5MM	1		

1976.01.20

H16

I 1

Block No.

F-21

Frame Body - Tool

www.ustGP.com

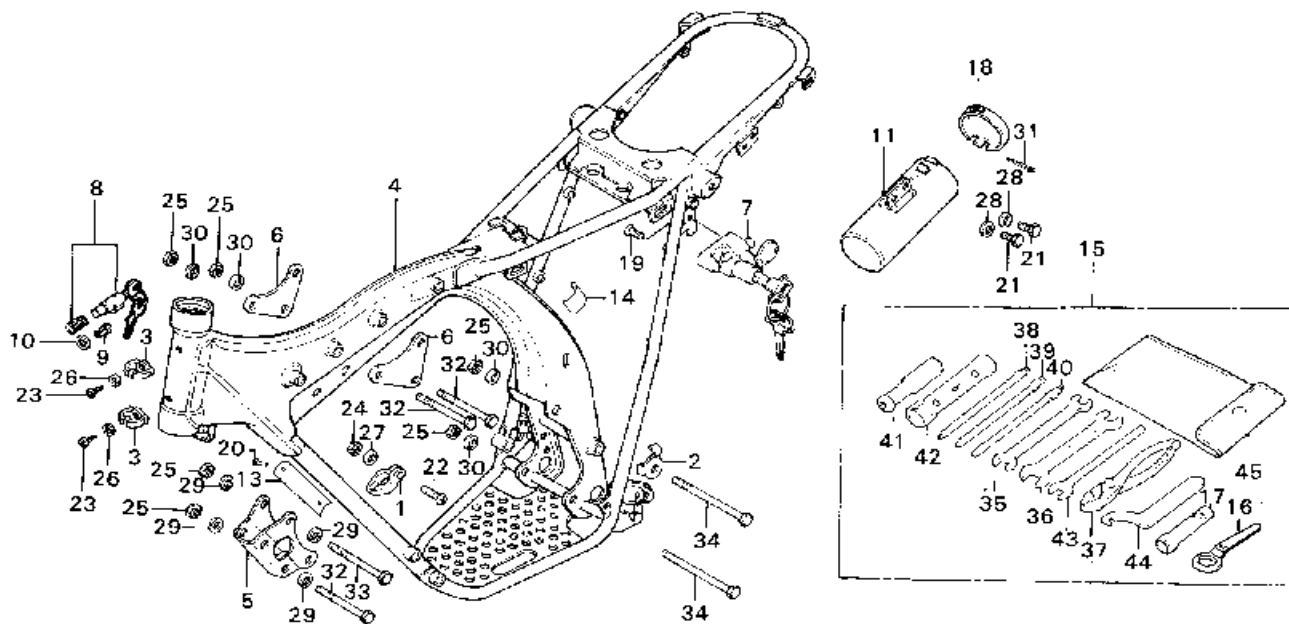

B366-02

Service Item	F.R.T.	Ref. No.	Part No.	Description	Reqd. No. TL125S	Serial No.	Area Code
		25	94030-08000	NUT, HEX., 8MM	9		
		26	94101-04000	WASHER, PLAIN, 4MM	2		
		27	94101-05000	WASHER, PLAIN, 5MM	1		
		28	94101-06000	WASHER, PLAIN, 6MM	2		
		29	94101-08000	WASHER, PLAIN, 8MM	8		
		30	94111-08000	WASHER, SPRING, 8MM	5		
		31	94201-20250	PIN, SPLIT, 2.0X25	1		
		32	95300-08070	BOLT, HEX., 8X70	5		
		33	95300-08090	BOLT, HEX., 8X90	2		
		34	95300-08111	BOLT, HEX., 8X111	2		
		35	99001-10120	SPANNER, 10X12	1		
		36	99001-14170	SPANNER, 14X17	1		
		37	99002-13500	PLIERS, 135	1		
		38	99003-10000	DRIVER, PLUS, #2	1		
		39	99003-20000	DRIVER, PLUS, #3	1		
		40	99003-30000	DRIVER, MINUS, #2	1		
		41	99003-50000	GKIP	1		
		42	99004-18190	WRENCH, BOX, P 18X19	1		
		43	99005-02000	BAR B, HANDLE	1		
		44	99007-45000	SPANNER, PIN, 45MM	1		
		45	99008-01600	BAG, TOOL	1		

1976.01.20

11