

# EURO IV - HIMALAYAN LS410 SERVICE MANUAL

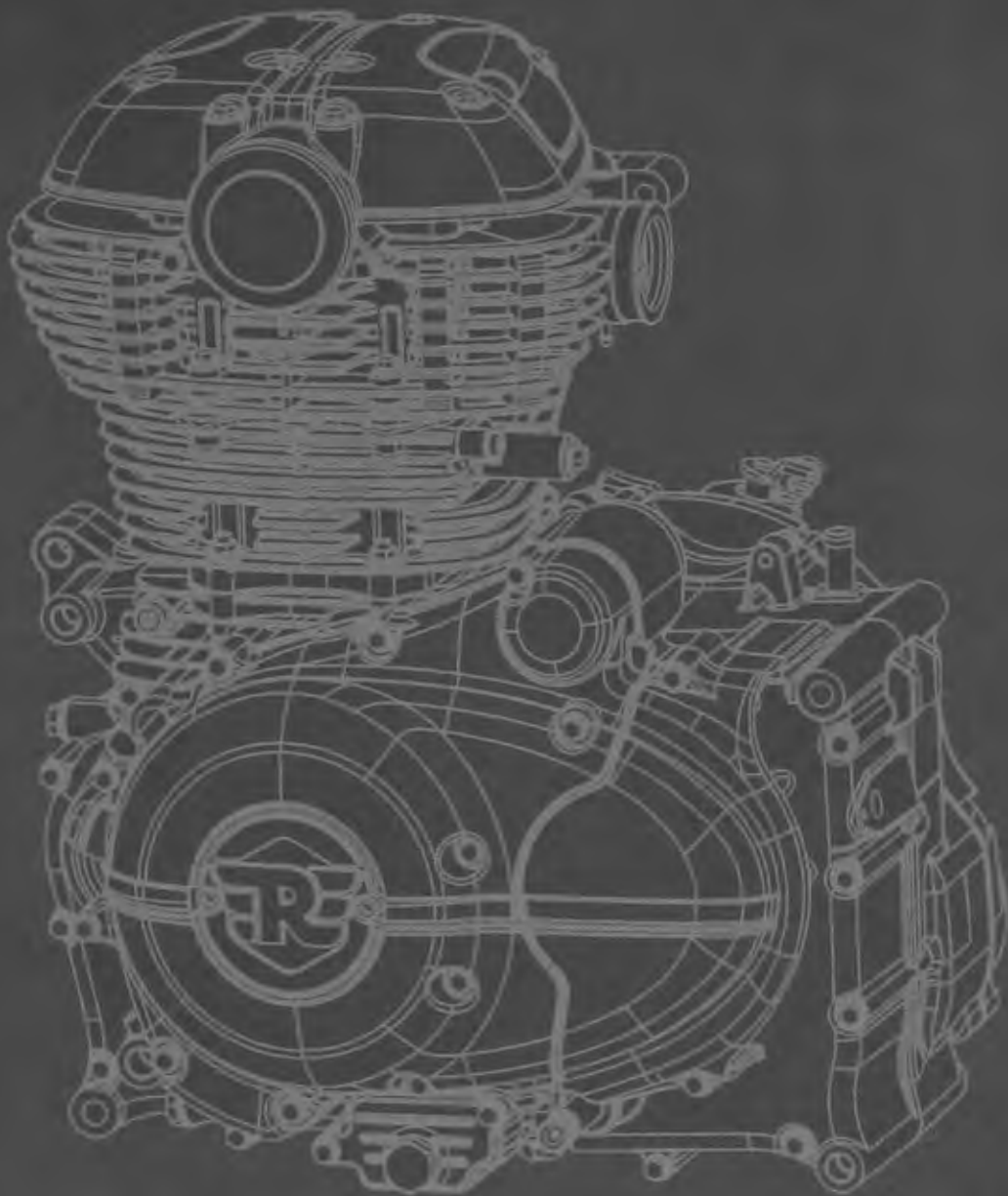

# PREFACE

---

"FIRST TIME RIGHT" is a very important element for enhancing Customer Satisfaction.

Royal Enfield is committed to upgrade the skills and knowledge of technicians so that they follow scientific repair techniques to ensure "FIRST TIME RIGHT" practices and carry out repairs accurately so that customers will enjoy trouble free performance at all times.

This manual will help in complete understanding of systematic procedures for dismantling, inspection, diagnosis and reassembly of the new range of Royal Enfield, LS 410 Single Cylinder, 4 Stroke, Overhead Cam, Air Cooled with Oil cooler Engine, in a simple and scientific manner.

While this manual is updated with latest Information and Specifications, at the time of going to print, due to continuous improvements being done to improve performance, some of the data, illustrations etc., in this manual may differ from the actual parts fitted in the engine.

Please do feel free to write to us at [customerservice@royalenfield.com](mailto:customerservice@royalenfield.com), if you have any queries, clarification, suggestions or feedback.

With warm regards

## **SERVICE HEAD QUARTERS**

Royal Enfield, A Unit of Eicher Motors Limited,  
Thiruvottiyur High Road, Thiruvottiyur, Chennai - 600 019.  
Phone: 044 - 4223 0400, Fax: 044 - 4201 1719  
E-mail: [support@royalenfield.com](mailto:support@royalenfield.com)  
Website: [www.royalenfield.com](http://www.royalenfield.com)

" © Copyright 2017 Royal Enfield (A Unit Eicher Motors Limited). All Rights Reserved. No part of this Service Manual shall be copied, distributed or otherwise dealt without the express permission in written from the Royal Enfield who remains the sole owner of this manual ."

Part No:	/ Oct. '17
----------	------------

# CONTENTS

SL.NO.	DESCRIPTION	PG.NO.	SL.NO.	DESCRIPTION	PG.NO.
1.	Engine Views LH & RH .....	3	12.	Wear Limits - LS 410 .....	66
2.	Technical Specifications .....	4	13.	Torque Values - LS 410 .....	67
3.	Exploded Views .....	5	14.	Precautions Before Engine Reassembly .....	69
4.	Gear Operating Positions - LS 410 .....	17	15.	Trouble Shooting .....	117
5.	Oil Circulation .....	19			
6.	Periodical Maintenance Chart - LS 410 .....	20			
7.	Servicing / Overhauling .....	21			
8.	Components Dismantling Sequence .....	22			
9.	Special Tools Usage List .....	23			
10.	Importance Notice Before Dismantling .....	24			
	Engine From Frame				
11.	Engine Dismantling Procedure Sequence .....	25			

# ENGINE VIEWS LH & RH

---



MODEL 06



MODEL 07

# TECHNICAL SPECIFICATIONS

<b>ENGINE &amp; ENGINE SYSTEMS</b>		
<b>A. ENGINE</b>		LS 410
1	Type	Single Cylinder, 4 Stroke SOHC, Air cooled, Fuel Injection
2	Bore	78 mm
3	Stroke	86 mm
4	Displacement	411 cc
5	Compression ratio	9.5 : 1
6	Max Power @ RPM	24.5 BHP(18.02 Kw @ 6500 RPM
7	Max Torque @ RPM	32 Nm @ 4000 RPM
8	Idle RPM	1250 ± 50 RPM @ EOT 80 deg
9	Starting	Electric Start
10	Air filter element	Paper element
11	Lubrication	Forced Lubrication, Wet Sump
12	Engine oil tank capacity (1 <sup>st</sup> Dry fill/ fill after complete Engine Overhaul)	2.3 litres
	Engine oil tank capacity(Routine Oil change/ Subsequent refills)	2.0 litres
13	Engine oil grade	SAE 15W 50 API SL Grade JASO MA 2
14	Cooling	Forced Air Cooled with Oil Cooler
<b>B. TRANSMISSION</b>		
1	Clutch	Wet, Multiplate
2	Primary drive	Gear
3	Primary ratio	2.312: 1
4	Gear box	5 Speed Constant Mesh
5	Gear Ratios	
	1 <sup>st</sup> Gear	2.916:1
	2 <sup>nd</sup> Gear	1.833:1
	3 <sup>rd</sup> Gear	1.428:1
	4 <sup>th</sup> Gear	1.173:1
5 <sup>th</sup> Gear	1:000:1	
6	Secondary drive	5/8" Chain & Sprocket
7	Secondary ratio	2.533:1
<b>C. FUEL</b>		
1	Fuel	Petrol
<b>D. IGNITION</b>		Digital Spark Ignition - TCI System
1	Ignition Advance / Ignition System	5 - 30° / Electronic Ignition, ECU/Variable
2	Spark plug	Bosch - UR5CC
3	Spark plug gap	0.7 to 0.8 mm
<b>E. ELECTRICALS</b>		
1	System	12V - DC
2	Generation	Alternator
3	Alternator Output	170W @ 1500 RPM

# EXPLODED VIEWS

## CYLINDER HEAD COVER ASSEMBLY

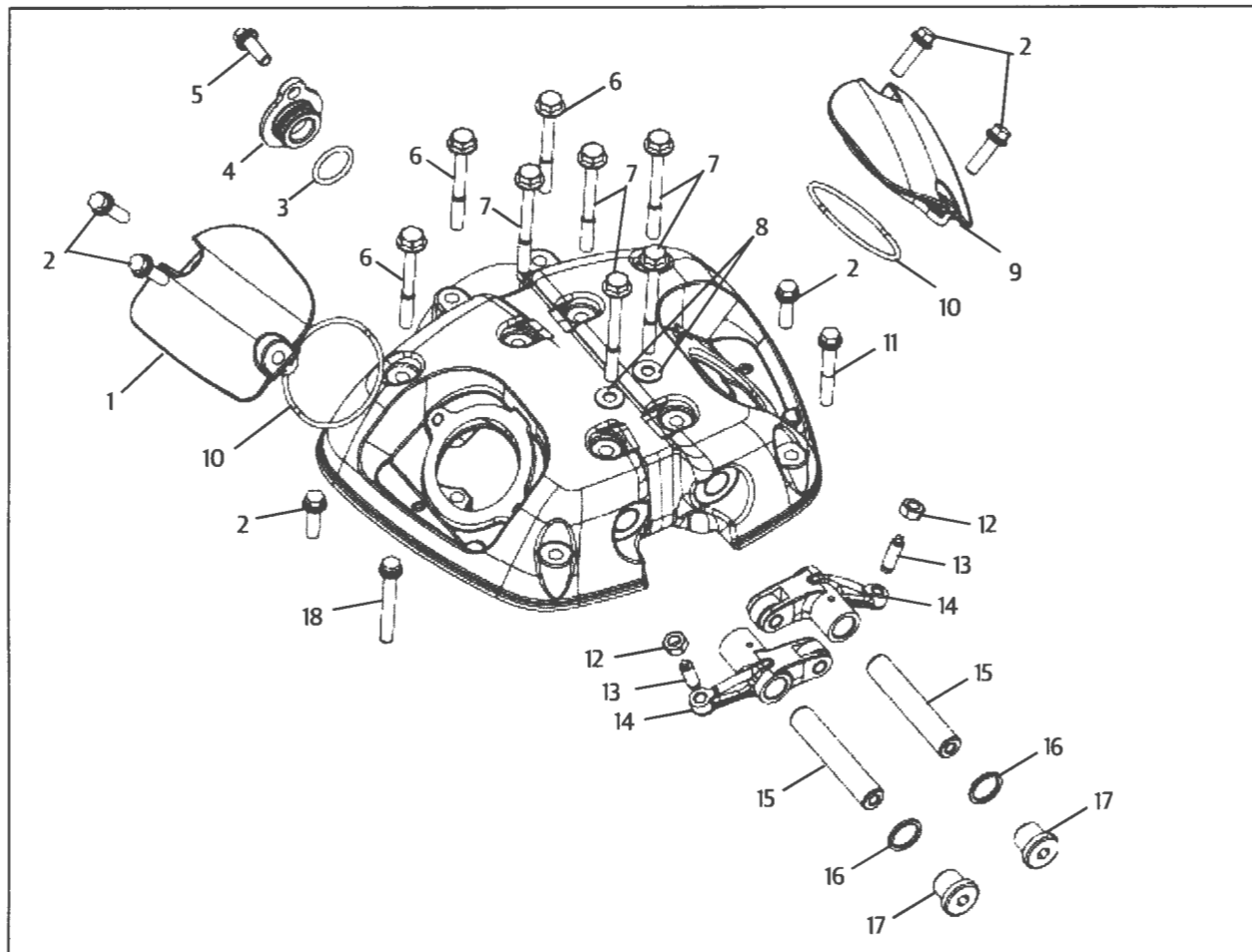

S.NO.	DESCRIPTION
1	Cover - Tappet Inlet
2	Hex Flange Bolt-M6 X 21
3	'O' Ring - Camshaft Hole
4	Plug - Camshaft Hole
5	Hex Flange Bolt - M6 X 16
6	Hex Flange Bolt - M6 X 55
7	Hex Flange Bolt - M6 X 60
8	Gasket Washer - 6.2X14X1
9	Cover - Tappet Exhaust

S.NO.	DESCRIPTION
10	O' Ring - Tappet
11	Hex Flange Bolt - M6 X 40
12	Nut - Tappet Adjusting
13	Screws Tappet Adjusting
14	Arm comp valve Rocker
15	Shaft Valve Rocker Arm
16	Copper Washer
17	Plug - Rocker Shaft
18	Hex Flange Bolt - M6 X 45

## CYLINDER HEAD ASSEMBLY

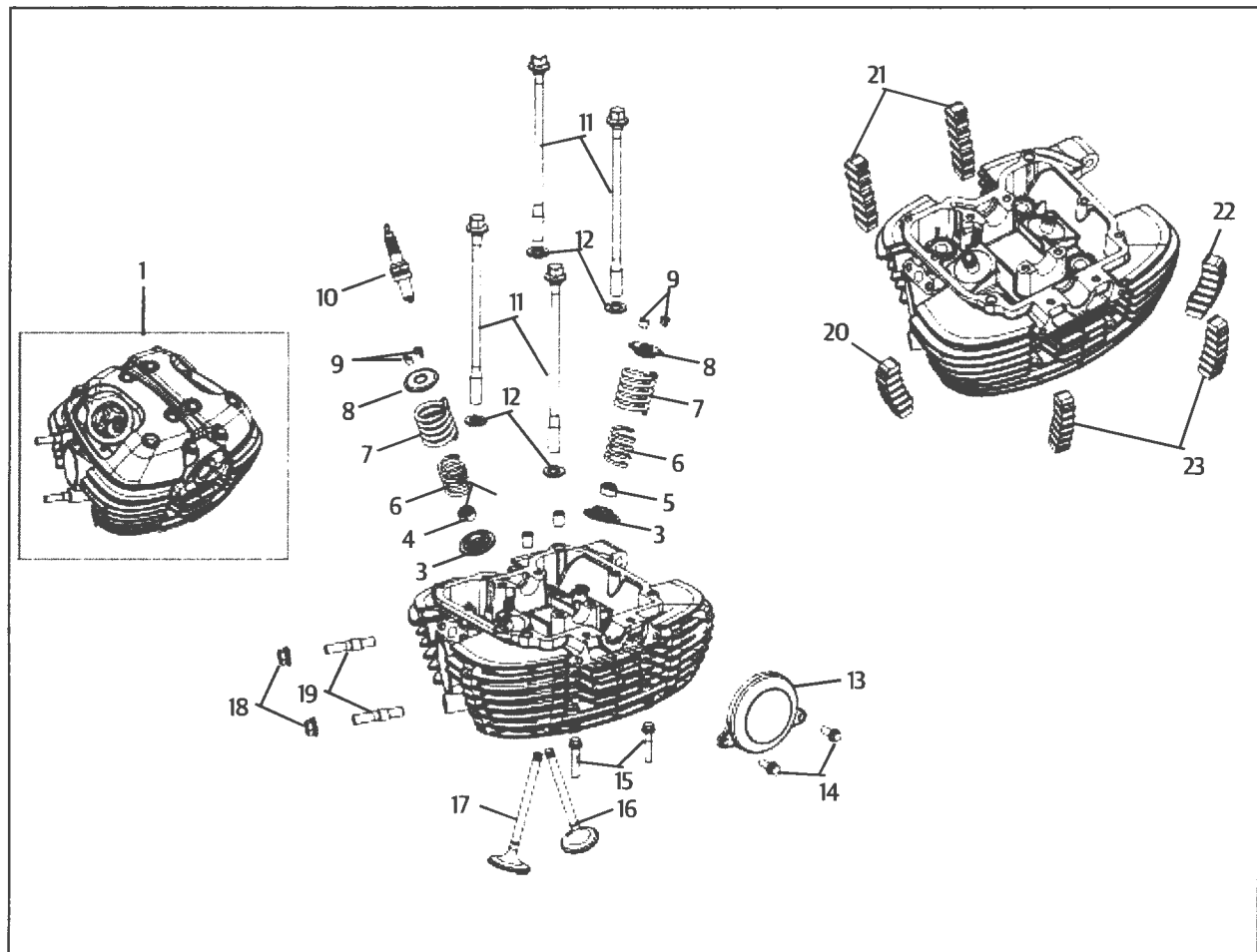

S.NO.	DESCRIPTION
1	Cylinder Head & Cover Box Assembly
2	Hollow Dowel (OD 9 X12), Cover cylinder
3	Seat Valve Spring
4	Seal Valve Stem - Intake
5	Seal Valve Stem - Exhaust
6	Spring Valve Inner
7	Spring Valve Outer
8	Retainer Valve Spring
9	Cotter Valve
10	Spark Plug
11	Bolt Cylinder Head M10 X 170
12	Washer Cyl Head Bolt

S.NO.	DESCRIPTION
13	Cover- Cam Center
14	Hex Flange Bolt - M6 X 16
15	Hex Flange Bolt - M6 X 30
16	Valve Exhaust
17	Valve Inlet
18	Nut M8 X 1.25
19	Stud Exhaust
20	Damper Pad - Cylinder Head Front
21	Damper Pad RH - Cylinder Head
22	Damper Pad - Cylinder Head Back
23	Damper Pad LH - Cylinder Head

## CYLINDER BARREL & PISTON ASSEMBLY

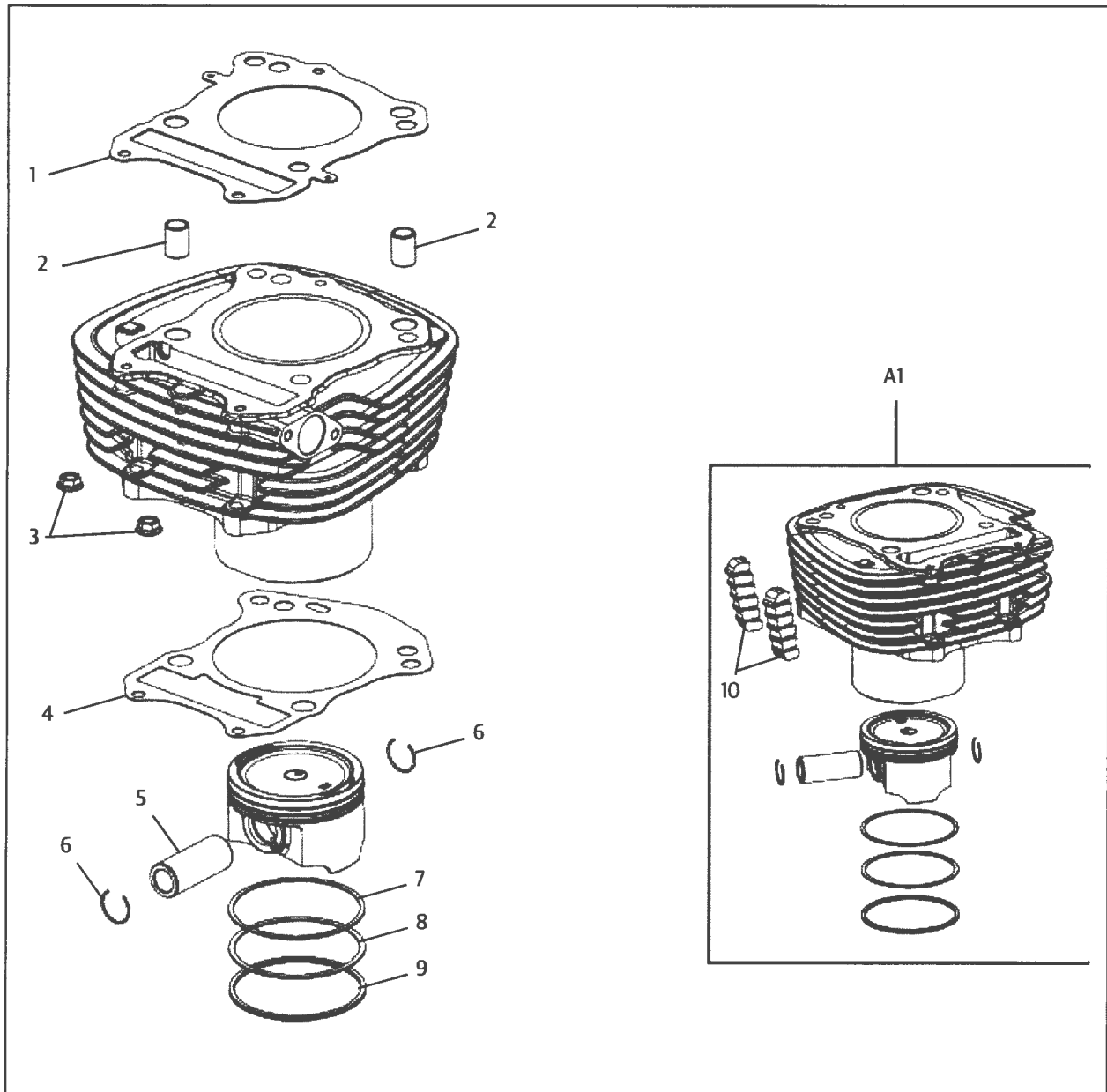

S.NO.	DESCRIPTION
1	Gasket - Cylinder Head MLS
2	Hollow Dowel (OD 13X18) - Cylinder Barrel
3	Hex Flange Nut - M6 X 1, Cylinder Barrel
4	Gasket - Cylinder Barrel
5	Pin Piston

S.NO.	DESCRIPTION
6	Circlip - Piston Pin
7	Ring - Piston 1st
8	Ring - Piston 2nd
9	Ring - Piston oil
10	Damper Pads Cylinder barrel

## CAM CHAIN ASSEMBLY

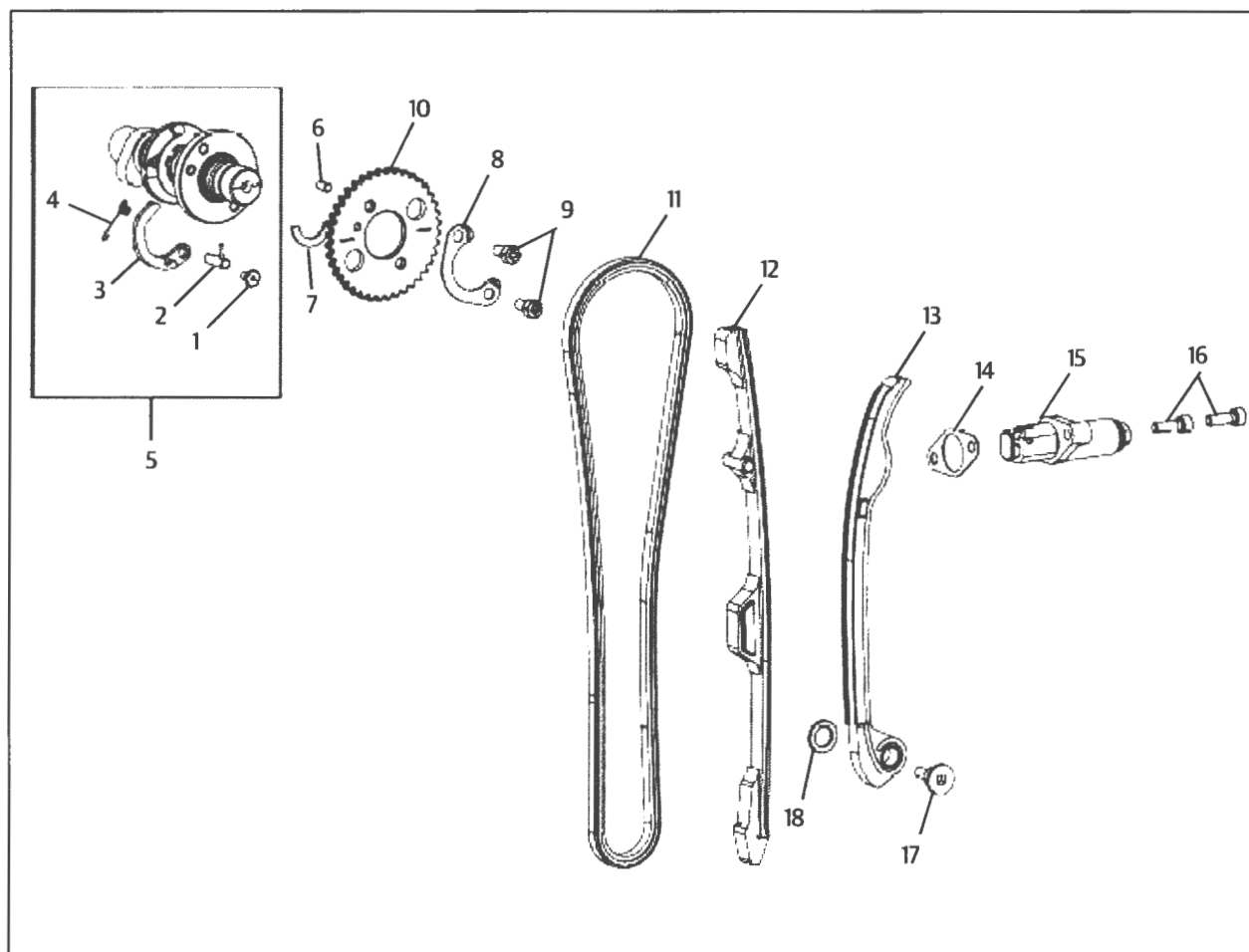

S.NO.	DESCRIPTION
1	Pin, Control Arm Pivot
2	Pin Assy Decomp
3	Arm, Decompression Control
4	Spring, Control Arm
5	Cam Shaft Assy
6	Pin, Camshaft Sprocket
7	'C' Ring, Camshaft
8	Lock Washer, Camshaft Sprocket
9	Bolt - M6 X 12, Camshaft Sprocket

S.NO.	DESCRIPTION
10	Sprocket- cam shaft
11	Cam Chain
12	Guide pad
13	Tensioner Pad
14	Gasket - Chain Tensioner
15	Auto Chain Tensioner Assy
16	Hex. Socket Head. Cap Screw, M6 X 25
17	Bolt Stepped M6 X 14, Cam Chain Tensioner
18	Washer - 6 X 18 X 1, Cam chain Tensioner Bolt

## CRANK TRAIN

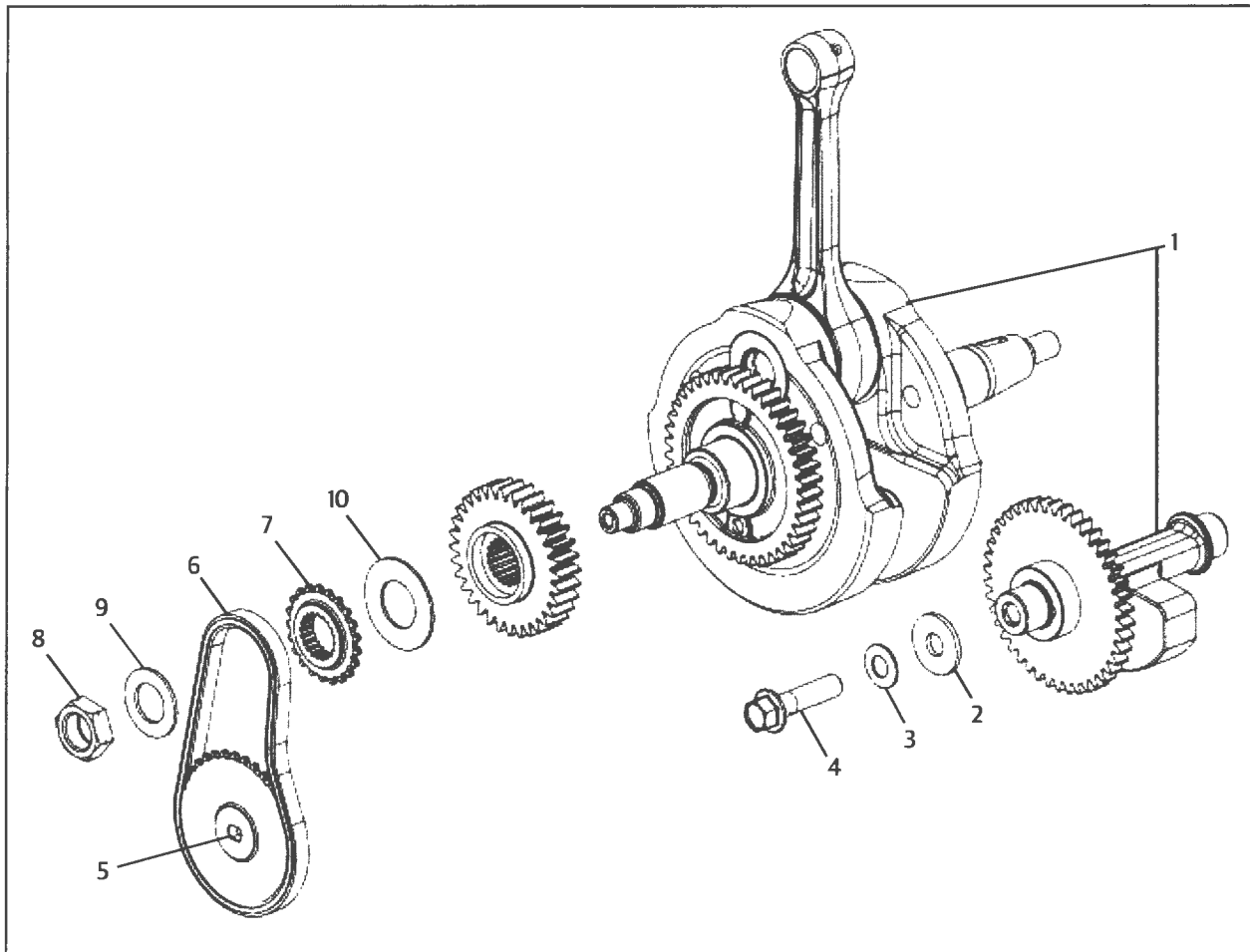

S.NO.	DESCRIPTION
1	Crank Shaft with Balancer Shaft Assembly
2	Washer 10.5 X 28 X 2.5, Crank Balancer
3	Washer Belleville, Crank Balancer Lock
4	Hex Flange Bolt - M10 X 20
5	Sprocket - Oil pump Driven
6	Chain oil pump
7	Sprocket - Oil pump Drive

S.NO.	DESCRIPTION
8	Nut- LH- M18, Oil Pump Drive Gear
9	Washer, Oil Pump sprocket Lock
10	Washer-22X4X1.5, Primary Drive Gear Thrust

## E-START SYSTEM

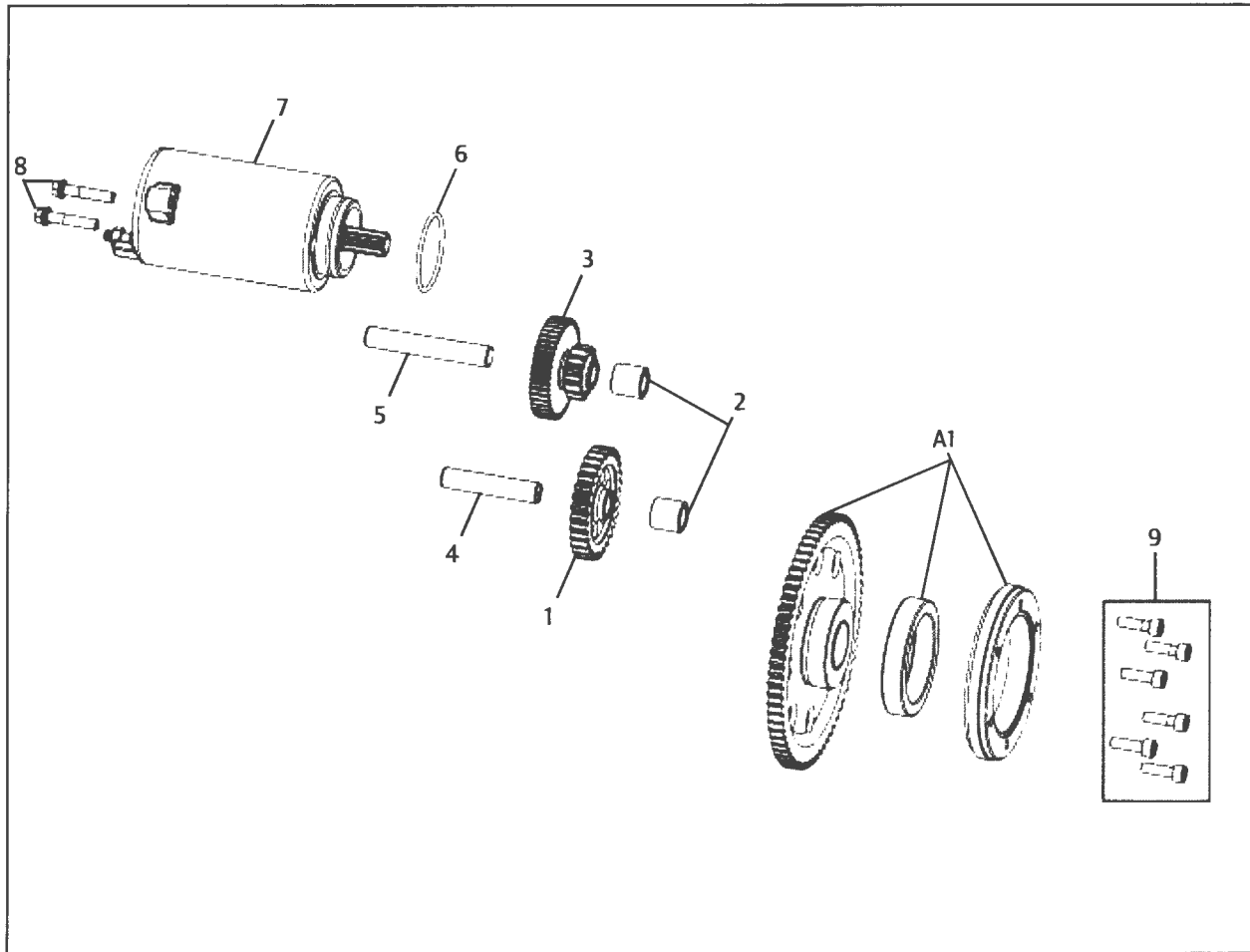

S.NO.	DESCRIPTION
A1	Starter Clutch Assembly
1	Gear, Starter Idle No.2
2	Spacer - Idler Gear
3	Gear, Starter Idle No.1 (Double Gear)
4	Shaft Starter Idle Gear No.2
5	Shaft Starter Idle Gear No.1

S.NO.	DESCRIPTION
6	'O' Ring Starter Motor
7	Starter Motor Assy
8	Hex Flange Bolt - M6 X 30
9	Hex Soc. Head Screw - M6 X 20

## COVER LH

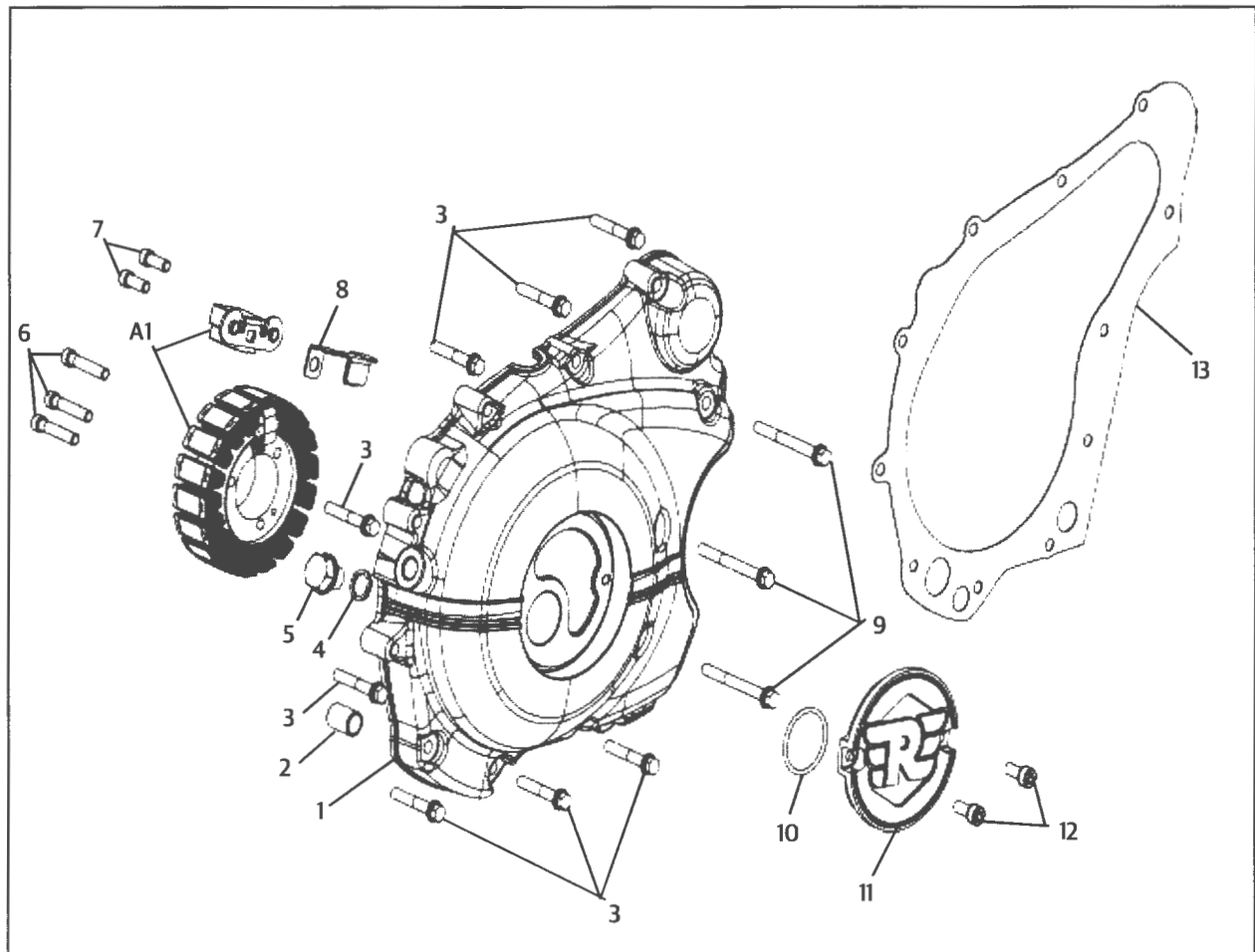

S.NO.	DESCRIPTION
A1	Magneto Assembly
1	Cover LH
2	Hollow Dowel - OD13 X 18, Cover LH
3	Hex Flange Bolt M6 X 35
4	Copper Washer, Oil Check Plug
5	Plug, Oil Check- M14 X 12
6	Hex Socket Head Screw M5 X 30

S.NO.	DESCRIPTION
7	Hex Socket Head Screw M5 X 15
8	Clamp Starter Wire
9	Hex Flange Bolt M6 X 55
10	O Ring
11	Cover Crankshaft Center
12	Hex Socket Head Screw M6 X 14
13	Gasket, Cover LH

## CRANKCASE LH

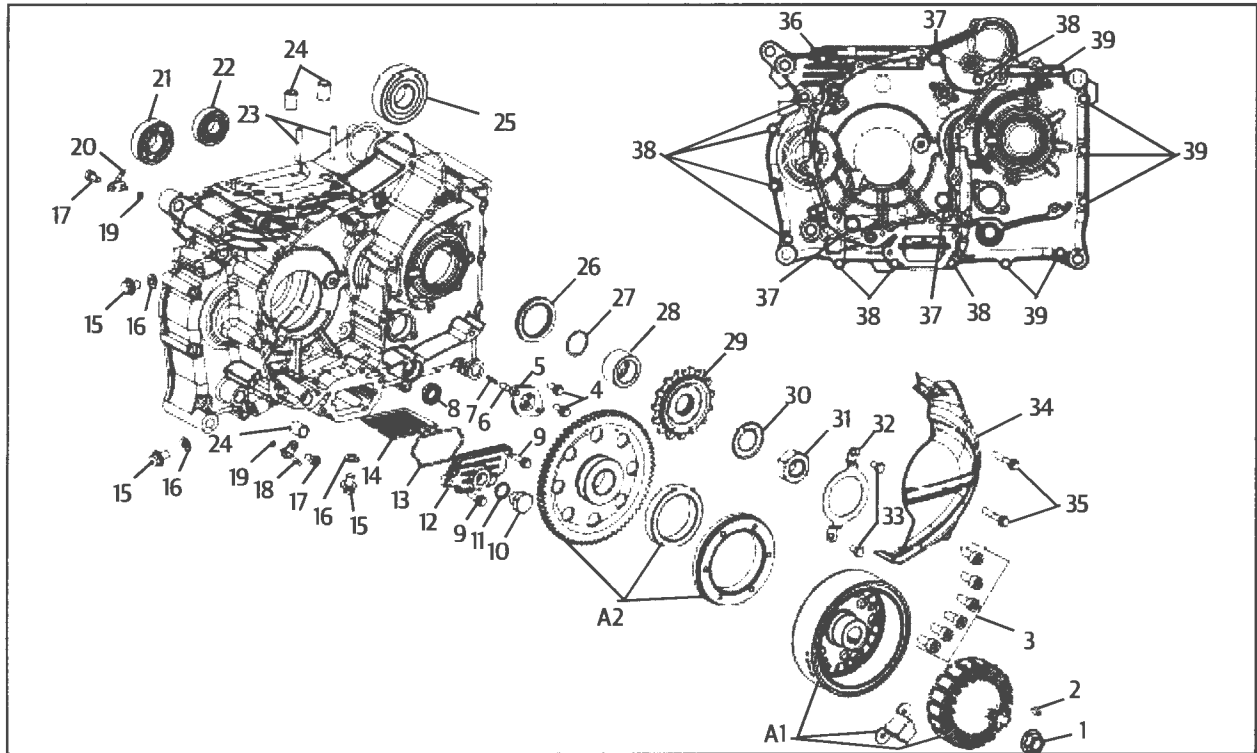

S.NO.	DESCRIPTION
A1	Magneto Assembly
A2	Starter Clutch Assembly
1	Hex Flange Nut - M12 X 1.25P X 11(W), Magneto
2	Key Woodruff
3	Hex Soc. Head Screw - M6 X 20
4	Hex Flange Bolt-M6X16 Gear Position Switch
5	Terminal Gear Position Switch
6	Pin, Gear Position
7	Spring, Gear Position Pin
8	Oil Seal, Gear Shift Shaft
9	Hex Flange Bolt - M6 X 20, Oil Strainer Cover
10	Plug M14 X 12, Oil Drain
11	Copper Washer Drain plug
12	Cover, Strainer
13	O-Ring, Oil Strainer Cover
14	Strainer Comp. Engine Oil
15	Hex Flange Bolt M8 X 12, Oil Gallery
16	Gasket Washer - 8.2 X 16 X 1, Oil Gallery Bolt
17	Hex Soc. Head Screw - M6 X 12
18	Jet Comp, Starter Clutch Oil
19	O-Ring - 4 X 1.2, Oil Jet

S.NO.	DESCRIPTION
20	Jet Comp, Piston Oil
21	Bearing (#6204),Crank Balancer
22	Bearing (#6203LU),COUNTER SHAFT,LH
23	Stud M6 X 37, Cylinder Barrel
24	Hollow Dowel - Od13 X 18, Crankcase Lh
25	Bearing (#6305LU), Drive shaft LH
26	Oil Seal, Drive Shaft
27	O-Ring, Spacer Engine Sprocket
28	Spacer, Engine Sprocket
29	Sprocket Comp - Final Drive Engine 15T (#525)
30	Tab Washer M20, Engine Sprocket Lock
31	Nut M20, Engine Sprocket
32	Retainer, Drive Shaft Oil Seal
33	Bolt M6 X 10, Drive Shaft Oil Seal Retainer
34	Sprocket Cover
35	Hex Flange Bolt - M6 X 35
36	Hex Flange Bolt - M8 X 100
37	Hex Flange Bolt - M8 X 70
38	Hex Flange Bolt - M6 X 60
39	Hex Flange Bolt - M6 X 85

## CRANKCASE RH

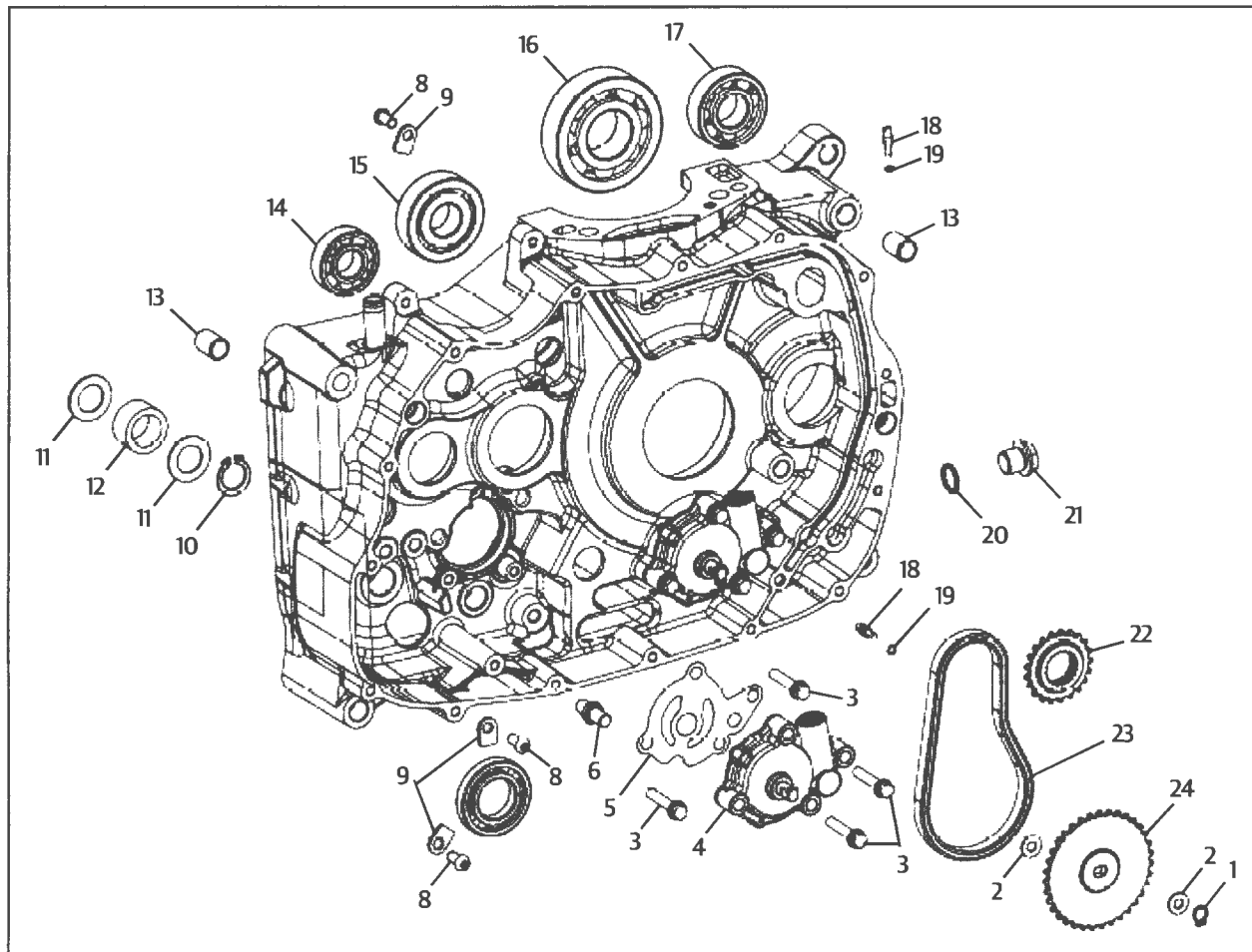

S.NO.	DESCRIPTION
1	Circlip Oil Pump Shaft
2	Washer 8 X 16 X 0.5 Oil pump sprocket
3	Hex Flanged Bolt - M6 X 30
4	Pump Assy, Oil
5	Gasket
6	Stopper, Gear Shift Arm
7	Bearing -#16005 , Gear Shift Drum RH
8	Hex socket head screw - M6 X 12
9	Retainer, Counter Shaft Bearing
10	Circlip 17 X 1, Kick Idle Gear.
11	Washer - 17 X 28 X 1, Kick Idle Gear Thrust
12	Spacer Drive Shaft

S.NO.	DESCRIPTION
13	Hollow Dowel (Od13X18), Cover-RH
14	Bearing - 6304, Counter Shaft RH
15	Bearing - 6203, Drive Shaft RH
16	Bearing - 6306, Crankshaft RH
17	Bearing - 6204, Crank Balancer
18	Oil jet
19	O-Ring - 4X1.2, Oil Jet
20	Copper Washer Drain plug
21	Plug oil check M14
22	Sprocket - Oil pump Drive
23	Chain oil pump
24	Sprocket - Oil pump Driven

## COVER RH

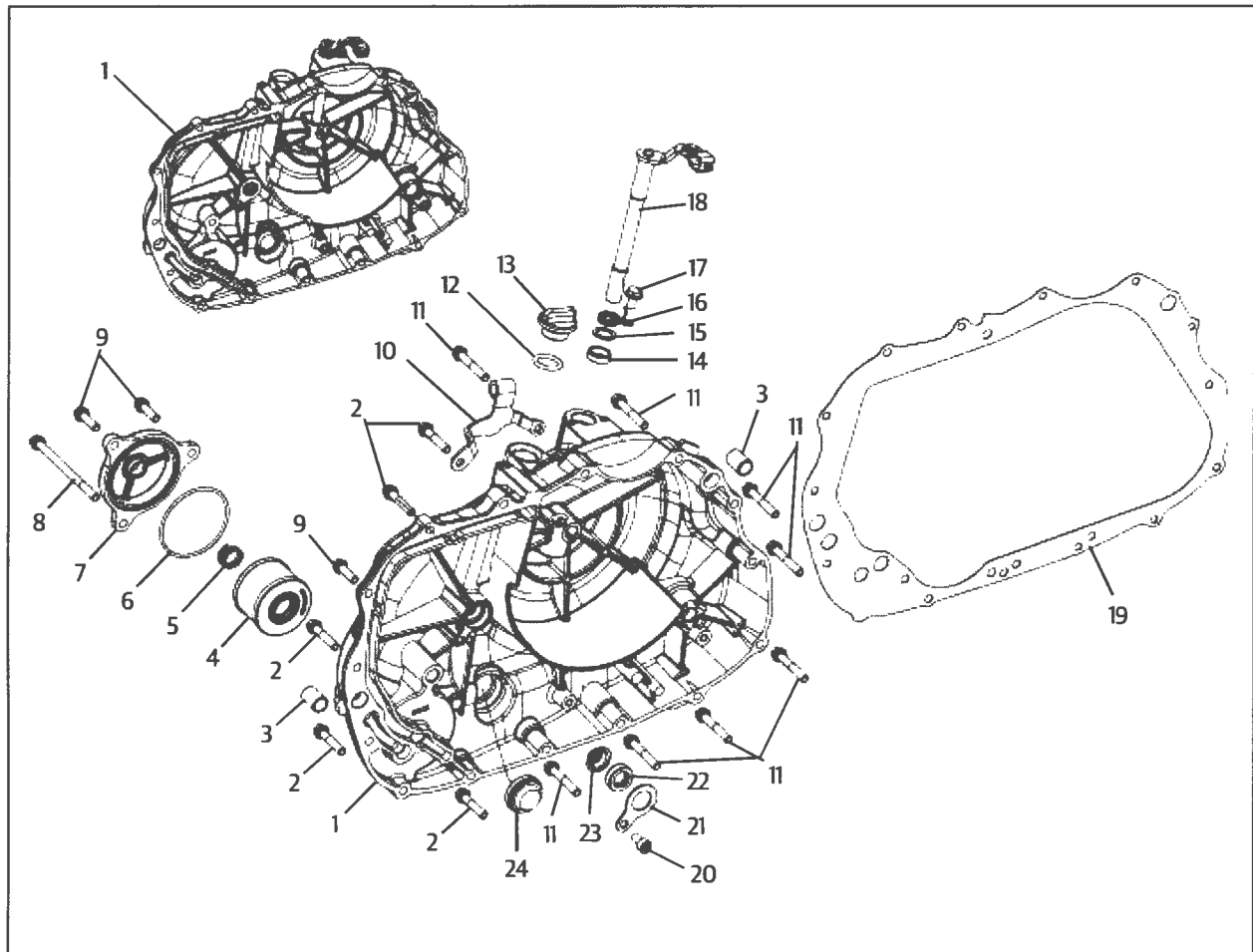

S.NO.	DESCRIPTION
1	Cover RH Assembly
2	Hex Flanged Bolt M6 X 1 X 30
3	Hollow Dowel (OD13X18), Cover-RH
4	Oil Filter
5	Spring Oil Filter
6	O Ring Oil Filter
7	Cap Oil Filter
8	Hex Flange Bolt - M6 X 70
9	Hex Flanged Bolt M6 X 1 X 20
10	Bracket, Clutch Release
11	Hex Flange Bolt - M6 X 37
12	O Ring Oil Filler

S.NO.	DESCRIPTION
13	Plug Oil Filler
14	Seal Clutch Release
15	Washer Clutch Release
16	Spring Clutch Release
17	Hex flange bolt M6 X 7
18	Shaft Clutch
19	Gasket Cover RH
20	Hex Socket Head Screw M6 X 12
21	Plate Retainer
22	Oil Seal Crankshaft RH
23	Jet, Crank Shaft RH
24	Lens Oil Level Check

## CLUTCH

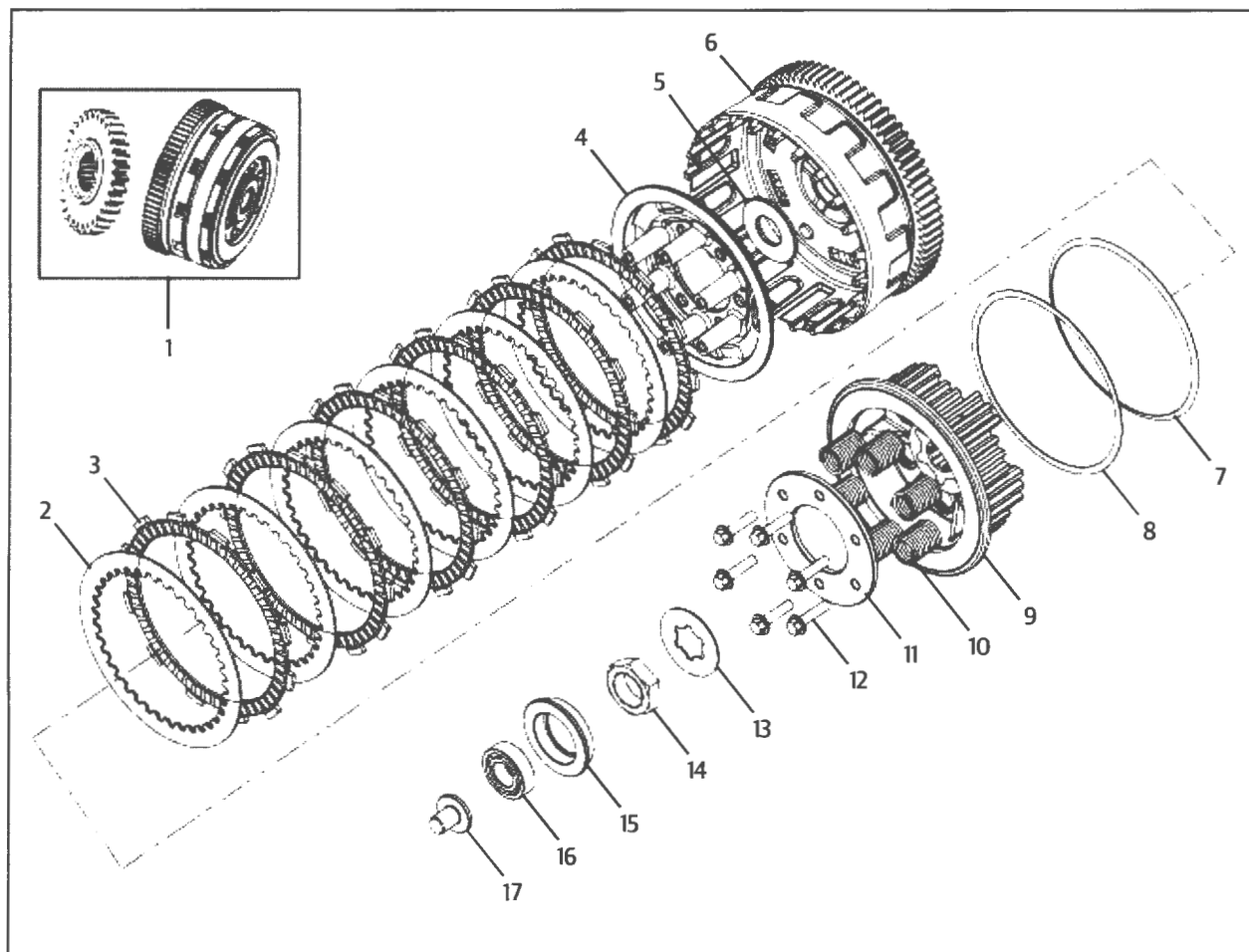

S.NO.	DESCRIPTION
1	Friction Plate
2	Plate Clutch
3	Wheel Clutch
4	Thrust Washer
5	Housing Assembly
6	Belleville Spring (Jadder spring)
7	Plain Washer (Jadder washer)
8	Hub Clutch With Ring
9	Compression Spring
10	Holder Clutch

S.NO.	DESCRIPTION
11	Hex Bolt M6
12	Washer, Clutch Sleeve Hub Lock
13	Nut M20 - Clutch Sleeve Hub
14	Bearing Cup
15	Bearing 17X35X10
16	Pin, Clutch Release

## TRANSMISSION

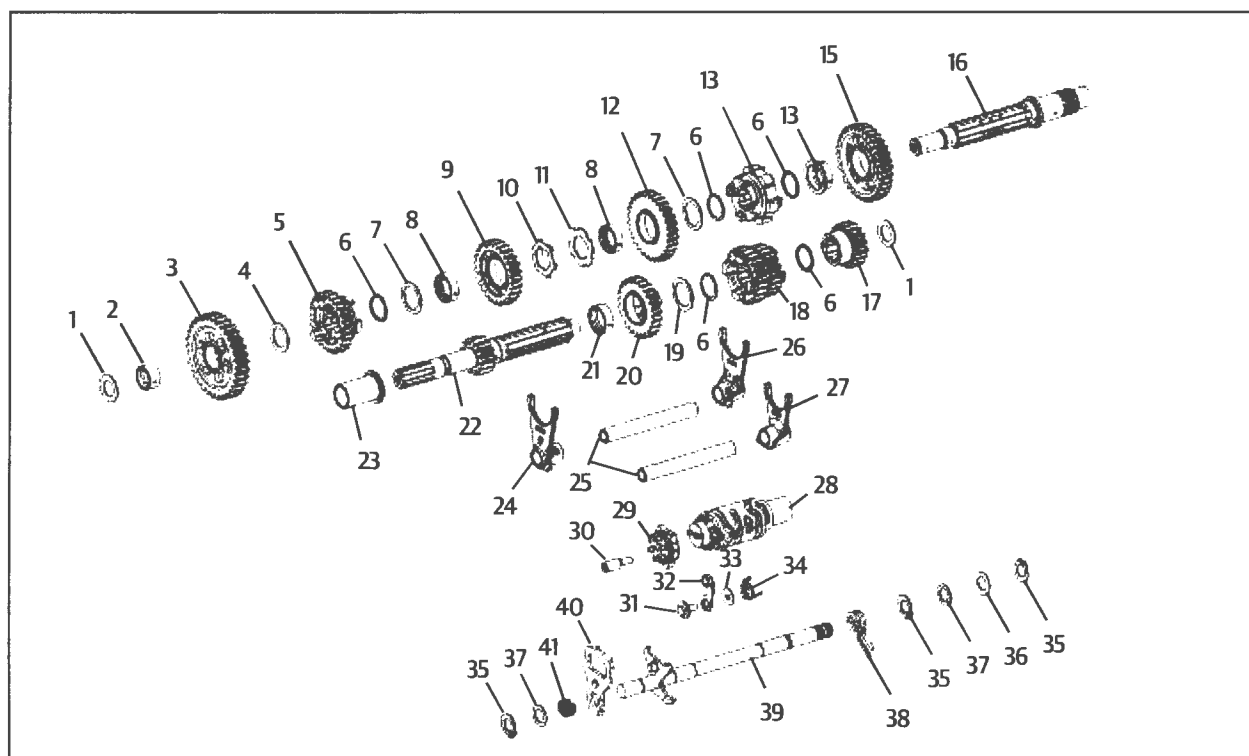

S. NO.	DESCRIPTION
1	Washer - 17 X 28 X 1, Drive Shaft thrust
2	Bush, 1st Driven Gear
3	Gear, 1st Driven
4	Washer - 20 X 30 X 1, 1st Driven Gear thrust
5	Gear, 5th Driven
6	Circlip 25 X 1.2, 5th Drive Gear
7	Washer, 3rd & 4th Driven Gear
8	Bush, 3rd & 4th Driven Gear
9	Gear, 4th Driven
10	Washer, thrust Washer Lock
11	Washer, 3rd & 4th Driven Gear thrust
12	Gear, 3rd Driven
13	Wheel, Sliding Dog
14	Bush, 2nd Driven Gear
15	Gear, 2nd Driven
16	Shaft Comp, Drive
17	Gear, 2nd Driven
18	Gear, 3rd & 4th Drive
19	Washer - 25 X 34 X 1, 5th Drive Gear thrust
20	Gear, 5th Drive
21	Bush, 5th Drive Gear

S. NO.	DESCRIPTION
22	Shaft Comp, Counter
23	Spacer primary drive
24	Fork, Gear Shift No.1
25	Shaft, Gear Shift Fork
26	Fork, Gear Shift No.2
27	Fork, Gear Shift No.3
28	Cam Comp, Gear Shift
29	Star Index, Gear Shift Cam
30	Stepped Bolt Hex Soc. Hd , Star Index
31	Bolt Stepped, Gear Shift Cam Stopper
32	Arm Stopper Comp, Gear Shift Cam
33	Washer - 6 X 18 X 1, Tensioner Bolt
34	Spring, Gear Shift Cam Stopper
35	Circlip-14 X 1, Gear Shift Shaft
36	Washer 14 X 25 X 0.8, Gear Shift Shaft Thrust
37	Shim, Gear Shift Shaft
38	Spring, Gear Shift Shaft Return
39	Shaft Comp, Gear Shift
40	Plate, Gear Shift Cam Drive
41	Spring, Gear Shift Cam Drive Plate

## OIL COOLER

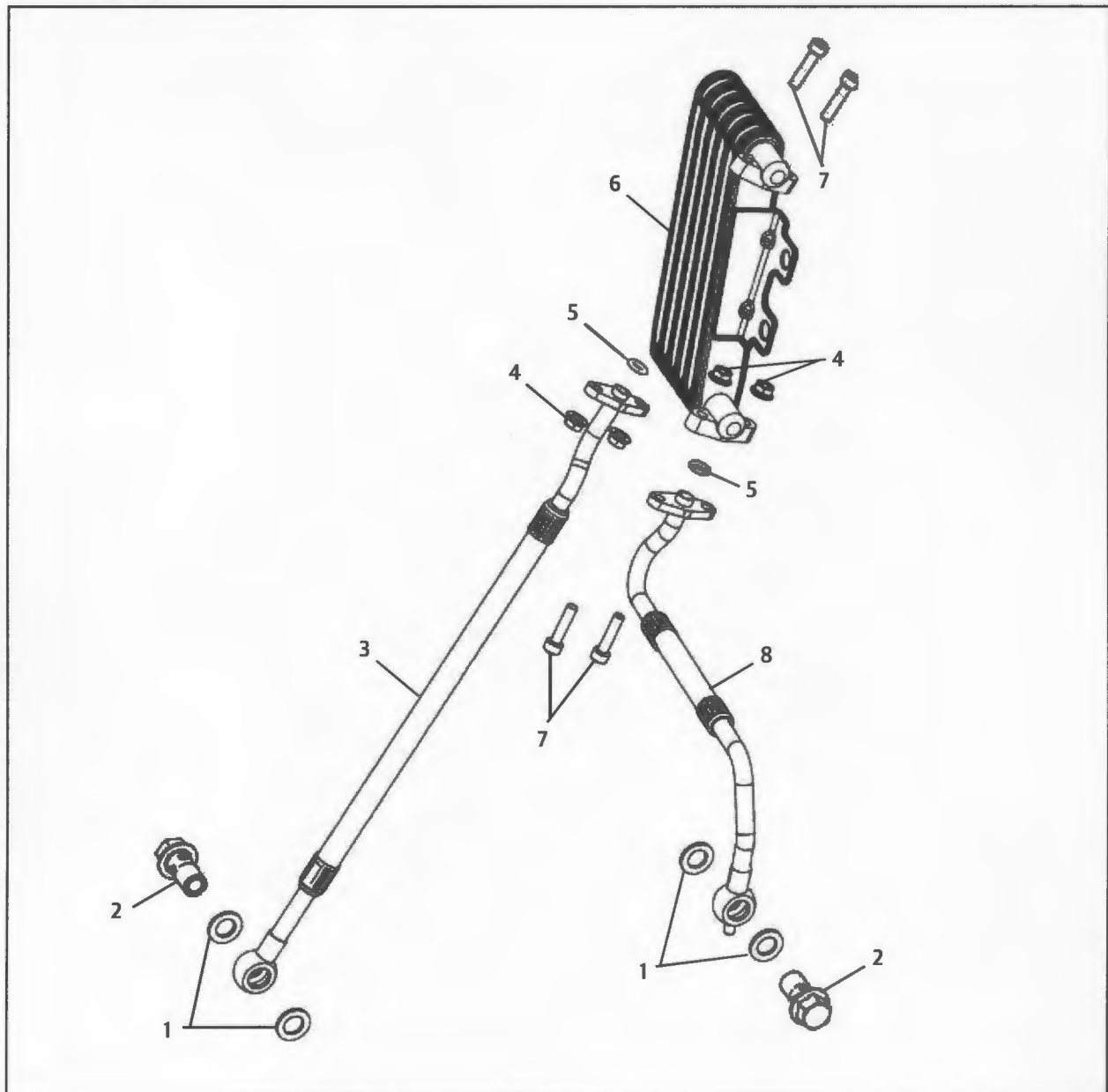

S.NO.	DESCRIPTION
1	Copper Washer
2	Bolt - Union Crankcase
3	Pipe Comp Engine Oil No 1
4	Hexagonal Nut M6

S.NO.	DESCRIPTION
5	O Ring Oil Coole
6	Oil Cooler
7	Hex.Socket Head Cap Screw M6 X 25
8	Pipe Comp Engine Oil No 2

# GEAR OPERATING POSITIONS - LS 410

## 1ST GEAR

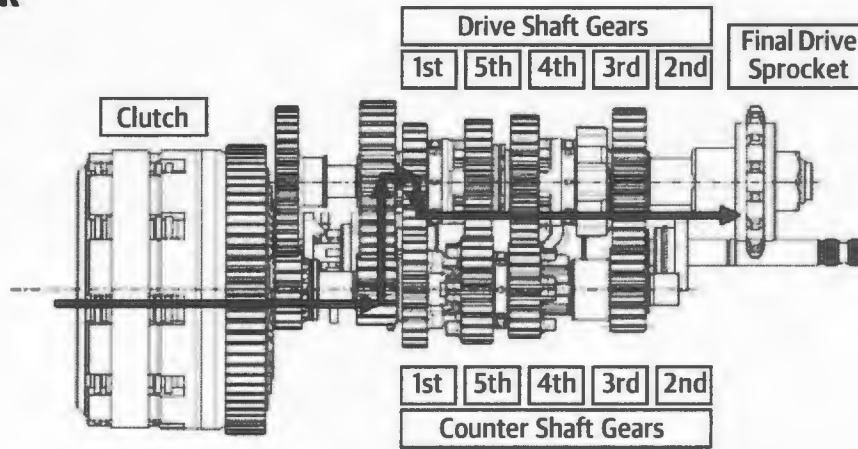

## 2ND GEAR

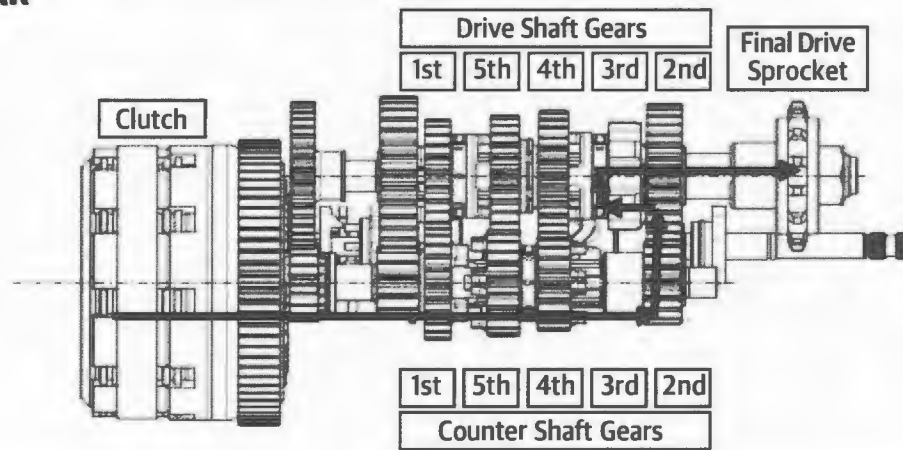

## 3RD GEAR

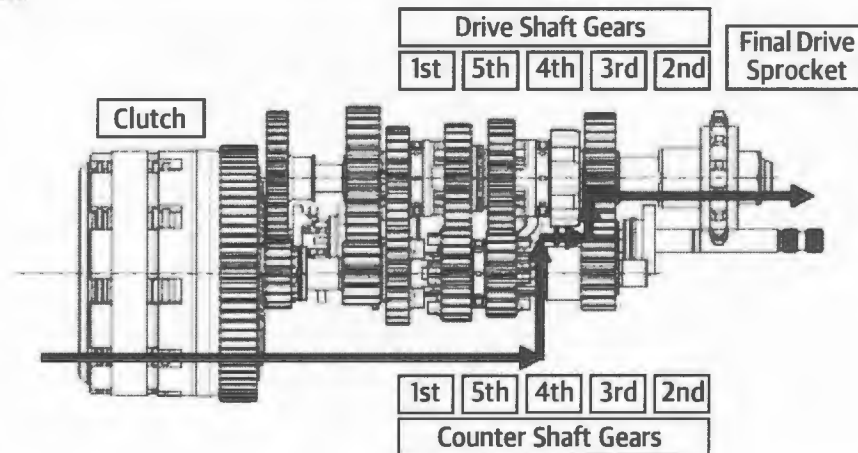

---

## 4TH GEAR

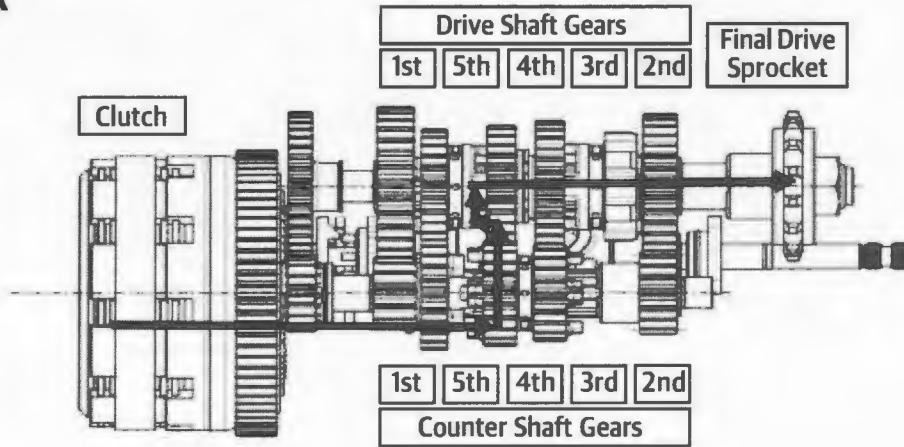

---

## 5TH GEAR

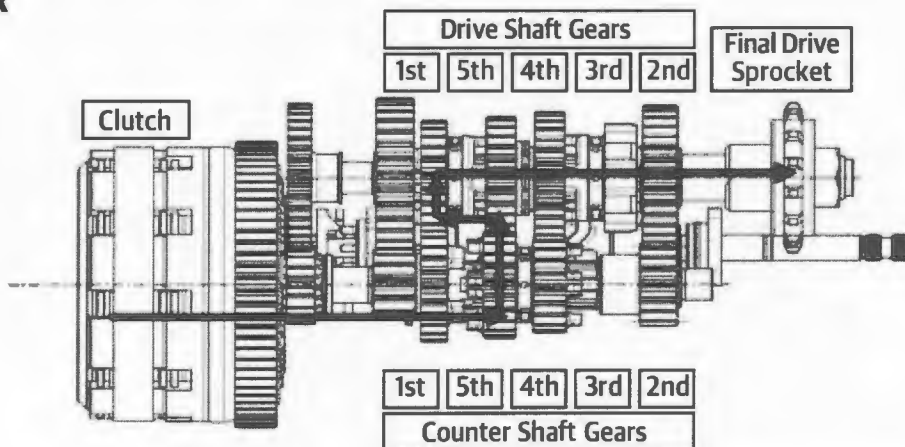



# PERIODICAL MAINTENANCE CHART - LS 410

The Periodical maintenance schedule detailed below is based upon average riding conditions and indicates the Intervals at which regular inspections, adjustments, replacements and lubrications must be carried out to help maintain your Himalayan motorcycle meticulously

If in case the motorcycle is used frequently in very dusty environment / severe climatic conditions / Poor Roads / stagnant water etc., the maintenance will need to be done earlier as may be required.

Contact a nearest Royal Enfield Authorised Dealer / Service Center to carry out the periodical maintenance and for any expert advice.

S. No.	DESCRIPTION	FREE SERVICE				PAID SERVICE							
		Whichever is earlier				Whichever is earlier							
	Kms (x 1000)	0.5	5	10	15	20	25	30	35	40	45	50	
	Months	1.5	6	12	18	24	30	36	42	48	54	60	
1	Engine Oil (Level check / Replace)	R	I	R	I	R	I	R	I	R	I	R	
		Check level at every 1000 Kms or earlier as required											
2	Oil Filter Element	R		R		R		R		R		R	
3	Engine oil strainer on crankcase LH	C		C		C		C		C		C	
4	Inlet / Exhaust Tappet setting	I&A	I&A	I&A	I&A	I&A	I&A	I&A	I&A	I&A	I&A	I&A	
5	Rubber hose, Inlet manifold *	I	I	R	I	R	I	R	I	R	I	R	
6	Oil cooler inlet & outlet pipes *	I	I	I	R	I	I	R	I	I	R	I	
7	Spark plug	C&A	C&A	C&A	R	C&A	C&A	R	C&A	C&A	R	C&A	
8	Accelerator Cable	I	I	R	I	R	I	R	I	R	I	R	
9	Clutch Plates				R			R			R		
10	Cam Chain / Chain Pads / Auto chain Tensioner	I	I	I	I	I	I	I	I	I	I	I&R	
11	Inlet / Exhaust valve seating (compression test) *						I					I	

**A : Adjust      C : Clean      I : Inspect      L : Lubricate      R : Replace**

\* Refer Service Manual.

# Check every time after vehicle is used for off road riding

For maintenance after 50,000 Kms. , please repeat same frequency specified above, in consultation with a Royal Enfield Authorised Dealer / Service Center.

---

## **SERVICING / OVERHAULING POSSIBLE WITHOUT DISMANTLING ENGINE FROM FRAME**

- Inlet & Exhaust Tappet adjustments
- Auto Chain Tensioner, Cam shaft assembly, Cam chain, pads
- Cylinder Head assembly
- Cylinder Barrel, Piston&Rings
- Clutch assembly
- Oil pump assembly
- Gears operating mechanism/ gear shift shaft oil seals
- Magneto Stator / Rotor Assembly
- Starter Clutch Assembly
- Starter Motor replacement
- Gear position sensor switch ,
- Final Drive sprocket.

## **SERVICING / OVERHAULING FOR WHICH ENGINE HAS TO BE REMOVED FROM FRAME**

- Crankcases opening
- Crank shaft / Balancer Shaft / Main Shaft / Counter Shaft / Gears / Gear Operator forks / Gear Selector Drum.
- Crank case bearings.

# COMPONENTS DISMANTLING SEQUENCE

## COMPONENTS DISMANTLING SEQUENCE TO REMOVE ENGINE FROM FRAME

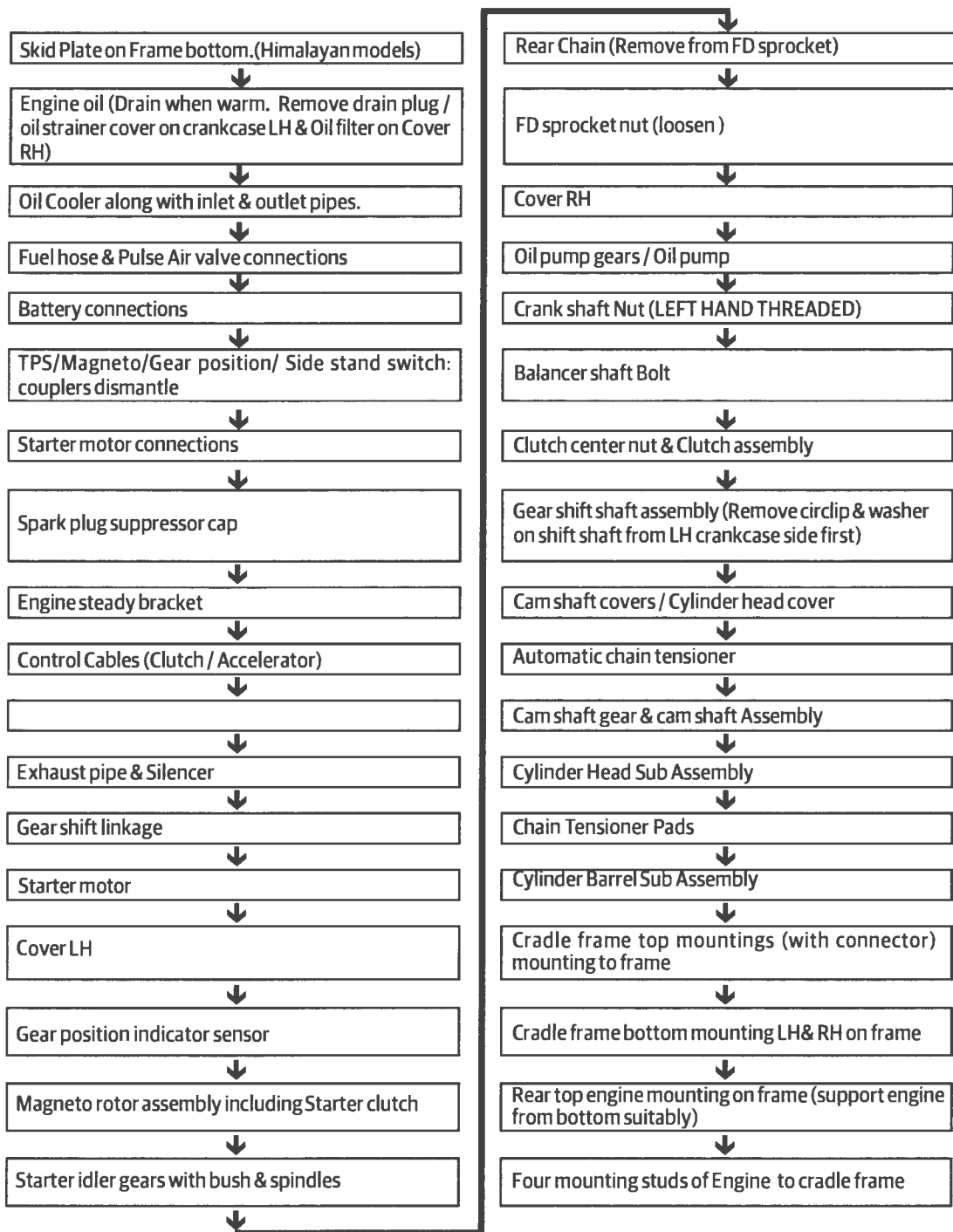

# SPECIAL TOOLS USAGE LIST

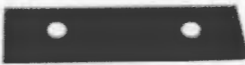
Part No.	Description	Photo	Usage purpose
ST-27527-2	Tappet Adjusting Tool		To adjust Tappets Clearance
ST-27528-2	Valve Spring Compressor		For removal of Inlet/ Exhaust valves from cylinder head
ST-27529-2	Piston Support Plate		To support Piston during assembly / Dismantling cylinder barrel & for removal/ installation of circlips in piston
ST-27530-2	Magneto Rotor Puller		To remove Magneto rotor from Crankshaft
ST-27531-2	Clutch Locking Plate		To compress Clutch springs during dismantling/assembly of clutch plates
ST-27532-2	Piston Circlip Installer		For installing Piston pin circlips
ST-27533-2	Crank Gears locking Tool		To lock Crankshaft /Clutch gear for removing/ tightening Crankshaft / clutch nut
ST-27534-2	Magneto rotor & FD sprocket locking Tool		To lock Magneto rotor/FD sprocket for removing tightening nut.

## IMPORTANT NOTES BEFORE DISMANTLING ENGINE FROM FRAME

1. Engine oil should always be drained when the engine is warm and before engine is dismantled from the frame..
2. Ensure oil cooler pipes are dismantled from engine and Oil cooler is removed from the frame.



**3. Ensure piston is at TDC on compression stroke:**





- Remove inspection bolt on cover LH to visually check if the timing mark on the magneto rotor is aligned with the reference mark on cover LH.
- If the marks are not aligned, remove cover- crankshaft center from cover LH & rotate magneto rotor nut **ONLY IN CLOCKWISE** direction, till the "+" reference mark on magneto rotor aligns with the mark on cover LH.



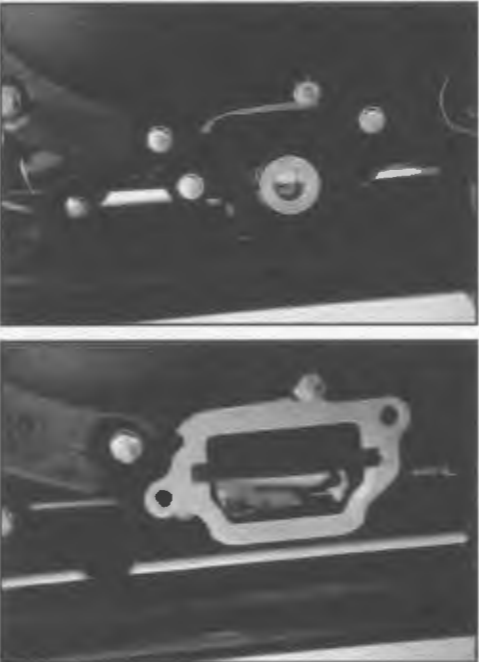





4. Remove pillion & rider seat
5. Remove fuel tank mounting fasteners at the rear end, Lift up tank slightly and disconnect fuel level sensor connection coupler to wiring harness.
6. Slide fuel tank towards the rear and gently pull out fuel tank from frame. Take care not to damage fuel tank while lifting up or while sliding towards the rear.
7. Remove side panel RH, Remove the battery holding strap, Disconnect battery connections.
8. Remove pulse air valve -inlet & outlet pipe connections from inlet manifold and cylinder head.
9. Remove exhaust pipe & silencer.
10. Disconnect all electrical connections & couplers: spark plug suppressor cap, magneto, pulsar coil, E start motor, throttle position switch, gear position indicator, side stand switch & earth terminals.
11. Remove engine steady plate from cylinder head & frame
12. Remove gear shift linkage from gear shaft on frame LH side
13. Remove clutch & accelerator cable connections from engine.
14. Remove rear chain.
15. Remove the bolts & studs mounting cradle frame to main frame at the front, rear & bottom after suitably supporting the engine at the bottom.
16. Remove the bolts & nuts mounting engine to cradle frame.



# ENGINE DISMANTLING SEQUENCE





S. No.	Aggregate to Assemble / Instructions	Fastener, Size, Tool Usage, Precautions, Photos	
1.	<p><b>Oil cooler</b></p> <ul style="list-style-type: none"> <li>■ Remove Inlet &amp; Outlet Banjo union bolts from LH&amp; RH Crankcase respectively &amp; allow oil to drain.</li> <li>■ Ensure the 4 washers are removed from the oil pipes / banjo Union</li> <li>■ Remove oil cooler along with inlet &amp; outlet pipes.</li> </ul>	<p><b>Bolt Union: M17</b> <b>Socket Spanner: 23mm</b></p> <p><b>NOTE:</b> Ensure Oil cooler mounting bolts are removed from frame bracket before removing oil cooler.</p>	
2.	<p><b>Oil drain plug</b></p> <ul style="list-style-type: none"> <li>■ Remove hex plug with copper washer from oil strainer housing on crankcase LH.</li> </ul>	<p><b>Hex Plug: M14 X 12</b> <b>Socket Spanner: 21 mm</b></p> <p><b>CAUTION:</b> Dispose drained oil only through an authorized recycling agency to prevent environment pollution.</p>	
3.	<p><b>Oil strainer</b></p> <ul style="list-style-type: none"> <li>■ Remove 2 hex flange bolts from strainer cover.</li> <li>■ Remove cover with 'O' ring.</li> <li>■ Pull out the strainer gently from crankcase</li> </ul>	<p><b>Hex flange bolt: M6 X 20</b> <b>Hex Socket: 8 mm</b></p>	



S. No.	Aggregate to Assemble / Instructions	Fastener, Size, Tool Usage, Precautions, Photos	
4.	<p><b>Oil Filter</b></p> <ul style="list-style-type: none"> <li>■ Remove 1 long Hex flange bolt from the bottom of il filter cover.</li>   <li>■ Remove 2 Hex flange bolts from the top of the oil filter cover.</li>   <li>■ Gently pull out of the oil filter element.</li> </ul>	<p><b>Hex flange bolt: M6 X 70</b> <b>Hex socket: 8mm</b></p> <p><b>CAUTION:</b> Remove bolts evenly &amp; slowly since cover is spring loaded. Ensure 'O' ring is removed from cover.</p>	
		<p><b>Hex flange bolts: M6 X 20</b> <b>Hex socket: 8mm</b></p>	
		<p><b>NOTE:</b> The filter element will be tight in cover RH, due to the rubber seal on the inside of the element seating on the spout.</p>	
5.	<p><b>Starter motor</b></p> <ul style="list-style-type: none"> <li>■ Remove 2 Hex flange bolts from Crankcase RH side.</li> </ul>	<p><b>Hex flange bolt: M6 X 30</b> <b>Socket spanner: 8mm</b></p> <p><b>NOTE:</b> Ensure Earth terminal is disconnected from the Hex flange bolt.</p>	





S. No.	Aggregate to Assemble / Instructions	Fastener, Size, Tool Usage, Precautions, Photos	
5.	<p><b>Starter motor</b></p> <ul style="list-style-type: none"> <li>■ Gently pull out starter motor from the spigot in crankcase LH&amp; remove.</li> </ul>		
6.	<p><b>Sprocket cover</b></p> <ul style="list-style-type: none"> <li>■ Remove 2 hex flange bolts, holding sprocket cover to crankcase LH.</li> <li>■ Remove cover.</li> </ul>	<p><b>Hex flange bolt: M6 X 35</b> <b>Socket Spanner- 8mm</b></p>	
7.	<p><b>Cover crankshaft center</b></p> <ul style="list-style-type: none"> <li>■ Remove 2 hex socket head screws, from the cover crankshaft center</li> <li>■ Remove cover.</li> </ul>	<p><b>Hex socket hd. screw: M6 X 14</b> <b>Allen Key: M5</b></p> <p><b>NOTE:</b> Remove 'O' ring if stuck to cover LH.</p>	
8.	<p><b>Cover LH</b></p> <ul style="list-style-type: none"> <li>■ Remove 3 long hex flange bolts from the rear side of cover LH.</li> </ul>	<p><b>Hex flange bolt: M6 X 55: 3 Nos.</b> <b>Hex flange bolt: M6 X 35: 8 Nos.</b> <b>Socket Spanner- 8mm</b></p> <p><b>NOTE:</b> Ensure the Magneto &amp; Gear position sensor wire couplers are disconnected before removing cover LH</p>	

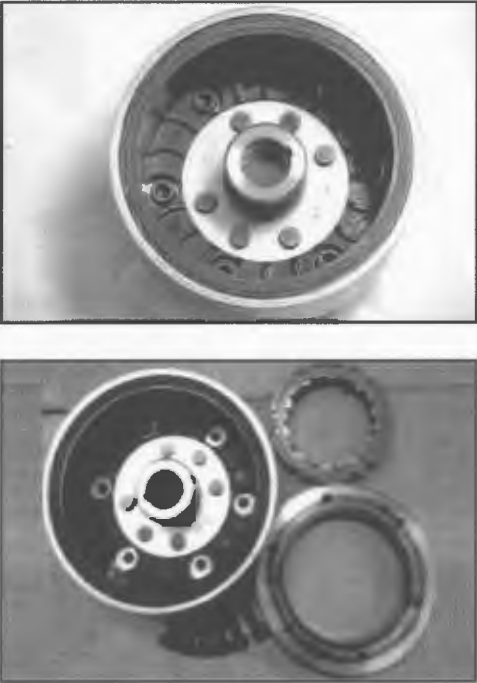

S. No.	Aggregate to Assemble / Instructions	Fastener, Size, Tool Usage, Precautions, Photos
8.	<p><b>Cover LH</b></p> <ul style="list-style-type: none"> <li>■ Remove 8 short hex flange bolts from the front &amp; center of cover LH.</li> <li>■ Gently tap on the tabs in cover LH to release: <ul style="list-style-type: none"> <li>- Stator from magneto rotor.</li> <li>- From the locating dowel at the bottom of crankcase LH.</li> </ul> </li> <li>■ Remove gasket.</li> </ul>	
9.	<p><b>Final drive sprocket nut:</b></p> <ul style="list-style-type: none"> <li>■ Straighten locking tab overhex U nut, using a suitable chisel.</li> <li>■ Locate special tool on FD sprocket &amp; remove hex "U" nut.</li> <li>■ Remove lock washer &amp; sprocket.</li> </ul>	<div data-bbox="597 1350 915 1493" style="border: 1px solid black; padding: 5px; margin-bottom: 10px;"> <p><b>Special Tool- ST-27534-2, Magneto Rotor &amp; FD sprocket locking Tool</b></p> </div> <div data-bbox="597 1543 915 1623" style="border: 1px solid black; padding: 5px; margin-bottom: 10px;"> <p><b>Hex "U" Nut: M20 Hex Socket: 32mm</b></p> </div>  



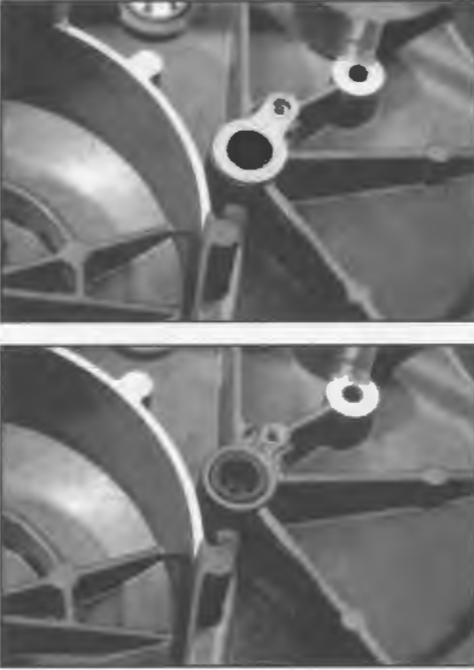

S. No.	Aggregate to Assemble / Instructions	Fastener, Size, Tool Usage, Precautions, Photos	
10.	<p><b>Gear position indicator</b></p> <ul style="list-style-type: none"> <li>■ Remove 2 hex flange bolts.</li> <li>■ Gently rotate &amp; pull out from crankcase LH.</li> <li>■ Remove the pin &amp; spring from counter shaft.</li> </ul>	<p><b>Hex flange bolt: M6 X 16</b>  <b>Hex Socket: 8mm</b></p>	<p><b>NOTE:</b>            Ensure 'O' ring is removed along with gear position indicator.</p> 
11.	<p><b>Starter Idle gears</b></p> <ul style="list-style-type: none"> <li>■ Remove 2 bushes from idle gear spindles.</li>   <li>■ Remove idle gear (middle).</li>   <li>■ Remove double gear (top).</li> </ul>	 <p>The three photos illustrate the removal of components from the starter assembly. The top photo shows the removal of bushes from the idle gear spindles. The middle photo shows the removal of the middle idle gear. The bottom photo shows the removal of the top double gear.</p>	

S. No.	Aggregate to Assemble / Instructions	Fastener, Size, Tool Usage, Precautions, Photos
11.	<p><b>Starter Idle gears</b></p> <ul style="list-style-type: none"> <li>Remove the 2 spindles.</li> </ul>	
12.	<p><b>Magneto Rotor</b></p> <ul style="list-style-type: none"> <li>Locate the special tool on 3 hex socket head screws inside magneto rotor to prevent it from rotating while loosening hex nut.</li> <li>Remove nut &amp; locate magneto rotor removing special tool on the threaded portion of the rotor.</li> <li>Tighten center bolt to remove magneto rotor, along with starter clutch assembly from LH shaft.</li> </ul>	<div data-bbox="594 842 915 963" style="border: 1px solid black; padding: 5px; margin-bottom: 10px;"> <p><b>Special Tool-ST-27534-2, Magneto rotor &amp; FD sprocket locking Tool</b></p> </div> <div data-bbox="594 1016 915 1094" style="border: 1px solid black; padding: 5px; margin-bottom: 10px;"> <p><b>Hex nut: M15 X Hex Socket: 18mm</b></p> </div> <div data-bbox="594 1251 915 1329" style="border: 1px solid black; padding: 5px; margin-bottom: 10px;"> <p><b>Special Tool: ST-27530-2, Magneto Rotor Puller</b></p> </div> <div data-bbox="594 1371 915 1577" style="border: 1px solid black; padding: 5px; margin-bottom: 10px;"> <p><b>NOTE:</b> Ensure special tool is fully threaded on the magneto damage to the rotor. rotor center, to prevent</p> </div> <div data-bbox="594 1608 915 1749" style="border: 1px solid black; padding: 5px;"> <p><b>NOTE:</b> Ensure woodruff key is removed from LH shaft.</p> </div>   

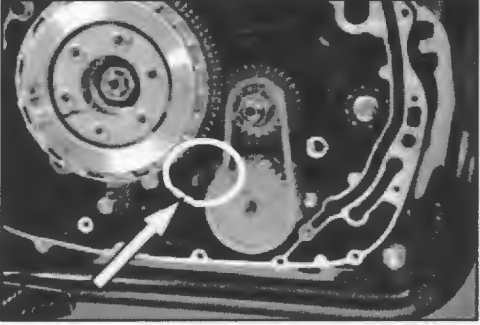

S. No.	Aggregate to Assemble / Instructions	Fastener, Size, Tool Usage, Precautions, Photos
13.	<p><b>Starter Clutch Assembly</b></p> <ul style="list-style-type: none"> <li>■ Gently rotate outer gear anticlockwise &amp; remove from starter clutch.</li> </ul>	
14.	<p><b>Starter Clutch Assembly</b></p> <ul style="list-style-type: none"> <li>■ Remove 6 hex socket head screws from inside magneto rotor and remove outer ring along with starter clutch.</li> <li>■ Remove starter clutch from outer ring.</li> </ul>	<div data-bbox="597 1052 914 1171" style="border: 1px solid black; padding: 5px; width: fit-content;"> <p><b>Hex socket hd screw: M6 X 20</b> <b>Allen Key: M5</b></p> </div> 
15.	<p><b>Cover RH</b></p> <ul style="list-style-type: none"> <li>■ Remove 2 Hex flange bolts holding clutch bracket to cover RH</li> </ul>	<div data-bbox="597 1539 914 1638" style="border: 1px solid black; padding: 5px; width: fit-content;"> <p><b>Hex flange bolt: M6 X 30</b> <b>Hex flange bolt: M6 X 37</b> <b>Hex Socket: 8mm</b></p> </div> 

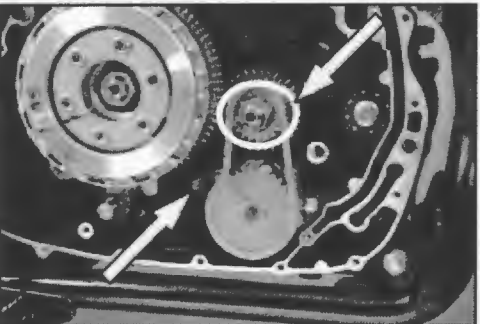
S. No.	Aggregate to Assemble / Instructions	Fastener, Size, Tool Usage, Precautions, Photos	
15.	<p><b>Cover RH</b></p> <ul style="list-style-type: none"> <li>■ Remove small Hex flange bolt (fully threaded) from front of cover RH.</li>   <li>■ Remove balance 11 Hex flange bolts.</li>   <li>■ Gently tap cover to release the same from the locating dowels on crankcase RH while simultaneously activating the clutch lever to remove cover RH</li>   <li>■ Remove RH cover gasket.</li> </ul>	<p>Hex flange bolt: M6 X 20 Hex Socket: 8mm</p>	
		<p>Hex flange bolts: M6 X 37 Hex Socket: 8mm</p>	
		<p><b>NOTE:</b> Ensure the clutch push pad does not fall off while removing Cover RH</p>	
			

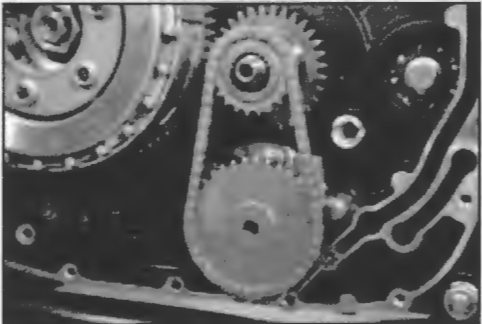
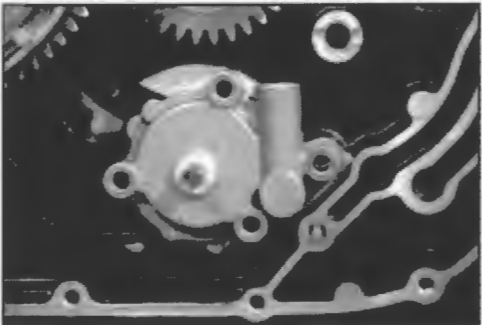
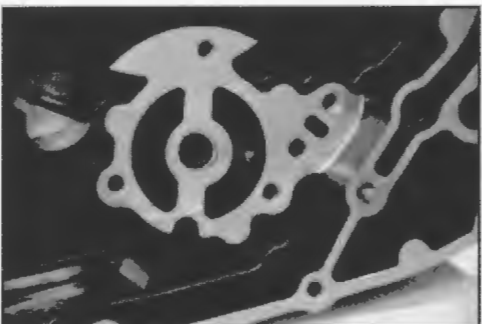

S. No.	Aggregate to Assemble / Instructions	Fastener, Size, Tool Usage, Precautions, Photos	
16.	<p><b>Jet-Crankshaft, Cover RH:</b></p> <ul style="list-style-type: none"> <li>■ Remove hex socket head screw with retainer plate.</li>   <li>■ Remove oil seal&amp;jet from cover RH.</li> </ul>	<p>Hex socket hd screw: M6X12 Allen key: M5</p>	
17.	<p><b>Oil jet in crankcase RH</b></p> <ul style="list-style-type: none"> <li>■ Gently pull out the Oil Jet located in the oil gallery near the oil pump gear in Crankcase RH.</li> </ul>		
18.	<p><b>Balancer shaft bolt</b></p> <ul style="list-style-type: none"> <li>■ Locate special tool between crankshaft gear &amp; clutch housing gear at the bottom to lock crankshaft.</li> <li>■ Loosen &amp; remove the Flanged hex bolt</li> <li>■ Remove big &amp; small black thrust washers.</li> </ul>	<p>Special Tool- ST-27533-2, Crank Gears locking Tool</p> <p>Hex flange bolt: M10 X 20 Hex Socket: 14mm</p>	

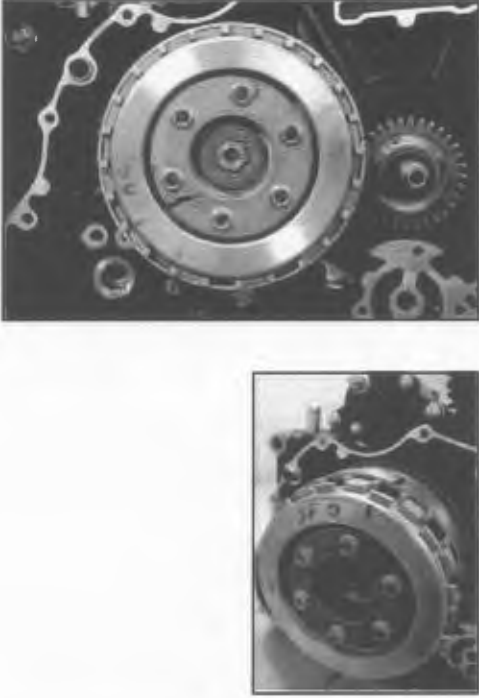



S. No.	Aggregate to Assemble / Instructions	Fastener, Size, Tool Usage, Precautions, Photos	
19.	<p><b>Crank shaft nut</b></p> <ul style="list-style-type: none"> <li>■ Locate special tool between crankshaft gear &amp; clutch housing gear at the bottom to lock crankshaft.</li> <li>■ Loosen hex nut by rotating it "CLOCK-WISE" &amp; remove.</li> <li>■ Remove small thrust washer.</li> </ul>	<p><b>Special Tool: ST-27533-2, Crank Gears locking Tool</b></p> <p><b>CAUTION:</b> LH thread nut. Loosen by rotating</p> <p><b>Nut LH thread: M18 Hex Socket: 24mm</b></p>	
20.	<p><b>Clutch Nut</b></p> <ul style="list-style-type: none"> <li>■ Remove clutch bearing with collar.</li> <li>■ Locate special tool between clutch gear &amp; crank shaft gear at the bottom to lock clutch housing.</li> <li>■ Loosen hex nut.</li> </ul>	<p><b>Special Tool: ST-27533-2, Crank Gears locking Tool</b></p> <p><b>Hex nut: M20 Hex Socket: 27mm</b></p>	  



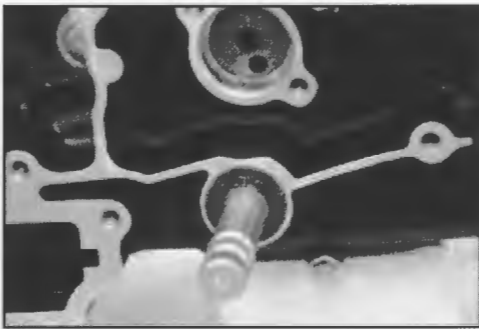

S. No.	Aggregate to Assemble / Instructions	Fastener, Size, Tool Usage, Precautions, Photos
21.	<p><b>Oil pump sprocket &amp; chain assembly</b></p> <ul style="list-style-type: none"> <li>■ Remove circlip on oil pump shaft.</li> <li>■ Remove thrust washer</li> <li>■ Remove pump sprocket along with the small gear on crankshaft assembly &amp; chain</li> </ul>	 
22.	<p><b>Oil pump assembly</b></p> <ul style="list-style-type: none"> <li>■ Remove 4 hex flange bolts holding oil pump &amp; remove pump.</li> <li>■ Remove pump gasket.</li> </ul>	<div data-bbox="597 1150 922 1234" style="border: 1px solid black; padding: 2px;"> <p>Hex flange bolts: M6 X 30 Hex Socket: 8mm</p> </div>  





S. No.	Aggregate to Assemble / Instructions	Fastener, Size, Tool Usage, Precautions, Photos
23.	<p><b>Clutch</b></p> <ul style="list-style-type: none"> <li>■ Remove splined washer from clutch main shaft.</li>   <li>■ Remove clutch assembly from clutch housing</li> </ul>	
24.	<p><b>Clutch plates</b></p> <ul style="list-style-type: none"> <li>■ Remove 2 hex screws diagonally opposite ends of the clutch holding plate.</li> <li>■ Position special tool over clutch holding plate such that the mounting holes of the tool is aligned with the 2 holes on clutch holding plate.</li> <li>■ Assemble 2 long M6 screws over the tool &amp; tighten till the special tool rests firmly on the clutch holding plate.</li> <li>■ Loosen &amp; remove the 4 hex screws from the clutch holding plate.</li> <li>■ Loosen the 2 screws slowly &amp; remove special tool.</li> </ul>	<div data-bbox="597 1163 917 1247" style="border: 1px solid black; padding: 5px;"> <p><b>Hex Screw: M6 X 10</b> <b>Hex Socket: 10mm</b></p> </div> <div data-bbox="597 1283 917 1367" style="border: 1px solid black; padding: 5px;"> <p><b>Special tool: ST-27531-2,</b> <b>Clutch locking plate</b></p> </div> 





S. No.	Aggregate to Assemble / Instructions	Fastener, Size, Tool Usage, Precautions, Photos
24.	<p><b>Clutch plates</b></p> <ul style="list-style-type: none"> <li>■ Remove clutch holding plate and the 6 springs.</li>   <li>■ Remove clutch hub along with the clutch plates.</li>   <li>■ Remove the clutch pressure plates, steel plates, Belleville &amp; steel washers.</li> </ul>	  

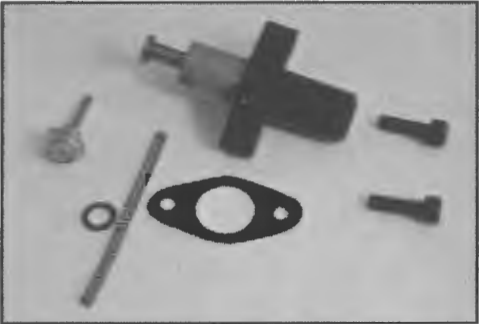



S. No.	Aggregate to Assemble / Instructions	Fastener, Size, Tool Usage, Precautions, Photos
25.	<p><b>Clutch housing</b></p> <ul style="list-style-type: none"> <li>■ Remove washer from main shaft.</li> <li>■ Remove clutch housing with bush from main shaft.</li> </ul>	
26.	<p><b>Crank shaft Gear</b></p> <ul style="list-style-type: none"> <li>■ Remove thrust washer.</li> <li>■ Remove splined gear &amp; bush.</li> </ul>	
27.	<p><b>Gear Shift Shaft</b></p> <ul style="list-style-type: none"> <li>■ Remove circlip and blackened washer from gear shift shaft on LH side.</li> </ul>	<div data-bbox="597 1535 919 1587" style="border: 1px solid black; padding: 2px;"> <p><b>Outside circlip plier</b></p> </div> <div data-bbox="597 1629 919 1829" style="border: 1px solid black; padding: 2px;"> <p><b>CAUTION:</b> Gear shift shaft cannot be removed if circlip &amp; washer are not removed from shaft on LH side.</p> </div> 

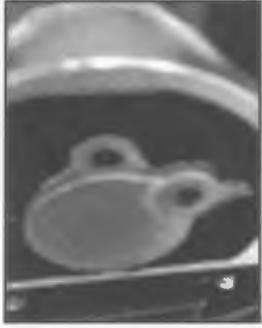



S. No.	Aggregate to Assemble / Instructions	Fastener, Size, Tool Usage, Precautions, Photos
27.	<p><b>Gear Shift Shaft</b></p> <ul style="list-style-type: none"> <li>■ Remove circlip from gear shift shaft on RH side.</li>   <li>■ Remove washer, spring &amp; gear selector.</li>   <li>■ Remove gear shift lever with spring &amp; washer.</li> </ul>	  
28.	<p><b>Gear Star Index stopper</b></p> <ul style="list-style-type: none"> <li>■ Remove stepped bolt holding arm stopper to Crankcase.</li> </ul>	<div data-bbox="597 1493 919 1577" style="border: 1px solid black; padding: 2px;"> <p>Stepped Bolt: M8 Hex Socket: 10mm</p> </div> 



S. No.	Aggregate to Assemble / Instructions	Fastener, Size, Tool Usage, Precautions, Photos
28.	<p><b>Gear Star Index stopper</b></p> <ul style="list-style-type: none"> <li>Remove arm stopper along with washer &amp; spring</li> </ul>	
29.	<p><b>Gear Star Index</b></p> <ul style="list-style-type: none"> <li>Remove stepped hex Socket Head bolt, holding star index to selector drum.</li> <li>Remove star index</li> </ul>	<p><b>Hex socket Hd screw: M6</b> <b>Allen key: M5</b></p>  
30.	<p><b>Drive shaft Spacer</b></p> <ul style="list-style-type: none"> <li>Remove circlip on drive shaft.</li> <li>Remove 1<sup>st</sup> thrust washer, spacer &amp; 2<sup>nd</sup> thrust washer.</li> </ul>	<p><b>Outside Circlip Player</b></p> 



S. No.	Aggregate to Assemble / Instructions	Fastener, Size, Tool Usage, Precautions, Photos	
31.	<p><b>Auto chain tensioner</b></p> <ul style="list-style-type: none"> <li>■ Remove hex bolt with spring from the center of auto chain tensioner body.</li>   <li>■ Remove 2 hex socket head screws &amp; gently pull out auto chain tensioner assembly.</li>   <li>■ Remove gasket.</li> </ul>	<p><b>Hex flange bolt: M8</b> <b>Hex Socket: 12mm</b></p>	<div data-bbox="602 512 922 646" style="border: 1px solid black; padding: 5px; margin-bottom: 5px;"> <p><b>CAUTION:</b> Open slowly &amp; carefully since spring loaded bolt.</p> </div> <div data-bbox="602 667 922 802" style="border: 1px solid black; padding: 5px; margin-bottom: 5px;"> <p><b>NOTE:</b> Ensure 'O' ring is removed from housing.</p> </div> <div data-bbox="602 835 922 957" style="border: 1px solid black; padding: 5px;"> <p><b>Hex Socket Hd screw: M6 X 25</b> <b>Allen Key: M5</b></p> </div> <div data-bbox="1122 390 1414 772" style="border: 1px solid black; margin-bottom: 5px;">  </div> <div data-bbox="938 804 1414 1125" style="border: 1px solid black; margin-bottom: 5px;">  </div> <div data-bbox="938 1161 1414 1482" style="border: 1px solid black;">  </div>
32.	<p><b>Inlet manifold</b></p> <ul style="list-style-type: none"> <li>■ Remove 2 hex socket head screws.</li>   <li>■ Remove inlet manifold with "O" ring</li> </ul>	<p><b>Hex Socket HdScrew: M6X25</b> <b>Allen key: M5</b></p>	<div data-bbox="1166 1524 1414 1850" style="border: 1px solid black;">  </div>

S. No.	Aggregate to Assemble / Instructions	Fastener, Size, Tool Usage, Precautions, Photos	
33.	<p><b>Cover- Cam Center</b></p> <ul style="list-style-type: none"> <li>Remove 2 hex flange bolts &amp; remove cover</li> </ul>	<p>Hex flange bolts: M6 X 16 Hex Socket: 8mm</p>	
34.	<p><b>Plug - Camshaft Hole</b></p> <ul style="list-style-type: none"> <li>Remove hex flange bolt.</li> <li>Rotate plug clockwise gently. DO NOT ATTEMPT to remove plug forcefully from the cylinder head cover.</li> </ul>	<p>Hex flange bolt: M6 X 16 Hex Socket: 8mm</p> <p><b>NOTE:</b> The plug will be tight in cylinder head cover. Do not attempt to remove before loosening all the cylinder head cover bolts.</p>	 
35.	<p><b>Tappet cover inlet</b></p> <ul style="list-style-type: none"> <li>Remove 2 hex flange bolts &amp; remove cover with O ring.</li> </ul>	<p>Hex flange bolts: M6X21 Hex Socket: 8mm</p>	

S. No.	Aggregate to Assemble / Instructions	Fastener, Size, Tool Usage, Precautions, Photos	
36.	<p><b>Tappet cover exhaust</b></p> <ul style="list-style-type: none"> <li>Remove 2 hex flange bolts &amp; remove cover with O ring.</li> </ul>	<p><b>Hex flange bolts: M6X21</b> <b>Hex Socket: 8mm</b></p>	
37.	<p><b>Plugs rocker shafts</b></p> <ul style="list-style-type: none"> <li>Loosen 2 hex socket head plugs from cylinder head cover RH side. (Do not remove plugs fully)</li> </ul>	<p><b>Hex Socket plug: M14 X 12</b> <b>Allen key: M8</b></p>	
38.	<p><b>Cylinder head cover</b></p> <ul style="list-style-type: none"> <li>Remove 2 long hex flange bolts with aluminum washers from the top RH side.</li> <li>Remove 3 long hex flange bolts from the top LH side</li> </ul>	<p><b>Hex flange bolt: M6 X 60</b> <b>Hex Socket: 8mm</b></p> <p><b>NOTE:</b> Aluminum washers are provided to prevent oil leak through the bolts.</p> <p><b>Hex flange bolt: M6 X 60</b> <b>Hex Socket: 8mm</b></p>	 

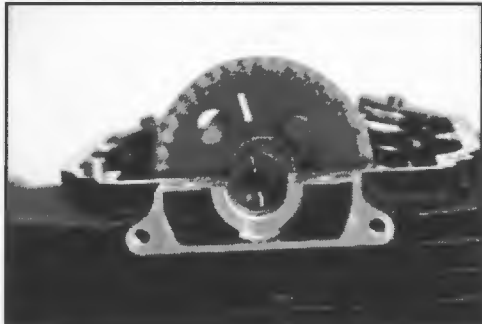

S. No.	Aggregate to Assemble / Instructions	Fastener, Size, Tool Usage, Precautions, Photos	
38.	<p><b>Cylinder head cover</b></p> <ul style="list-style-type: none"> <li>■ Remove 3 medium Hex flange bolts from the LH side.</li>   <li>■ Remove 2 long Hex flange bolts from RH side.</li>   <li>■ Remove 2 fully threaded Hex flange bolts from inlet &amp; Exhaust tappets opening.</li> </ul>	<p><b>Hex bolt: M6X55Hex Socket: 8mm</b></p>	
		<p><b>Hex flange bolt: M6 X 40 EX Hex flange bolt: M6 X 45 IN Hex Socket: 8mm</b></p>	
		<p><b>Hex bolt: M6X16 Hex Socket: 8mm</b></p>	
39.	<p><b>Plug camshaft hole</b></p> <ul style="list-style-type: none"> <li>■ Remove small cam shaft cover.</li> </ul>		

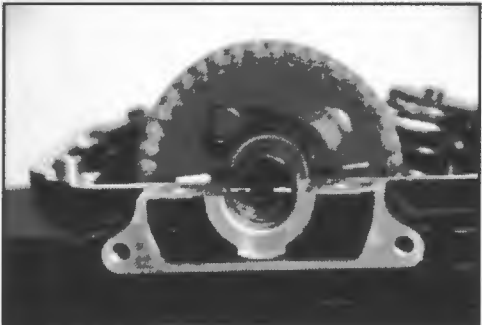

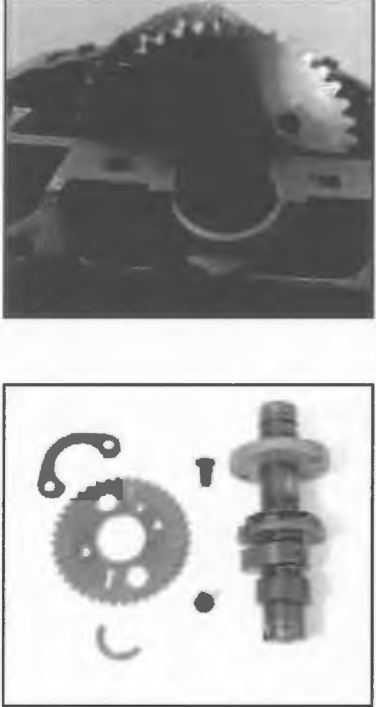
S. No.	Aggregate to Assemble / Instructions	Fastener, Size, Tool Usage, Precautions, Photos
40.	<p><b>Cylinder head cover</b></p> <ul style="list-style-type: none"> <li>Remove cylinder head cover by gently tapping on the pegs provided.</li> </ul>	
41.	<p><b>Rocker Shaft Plug screws</b></p> <ul style="list-style-type: none"> <li>Remove the 2 hex socket plug screws (Loosened earlier) with their copper washers from the cylinder head cover.</li> </ul>	
42.	<p><b>Shaft - Rocker arms</b></p> <ul style="list-style-type: none"> <li>Locate 2 long suitable M8 hex screws into the rocker shaft threads &amp; pull out the shafts.</li> </ul>	<div data-bbox="597 1150 915 1234" style="border: 1px solid black; padding: 2px;"> <p>Hex flange bolts: M8 Hex Socket: 10mm</p> </div> 
43.	<p><b>Rocker arms</b></p> <ul style="list-style-type: none"> <li>Remove inlet &amp; exhaust rocker arms.</li> </ul>	



S. No.	Aggregate to Assemble / Instructions	Fastener, Size, Tool Usage, Precautions, Photos	
44.	<p><b>Spark plug</b></p> <ul style="list-style-type: none"> <li>■ Remove spark plug from cylinder head.</li> </ul>	<p><b>Spark plug M10 Deep Hex Socket 16mm</b></p>	
45.	<p><b>Cam shaft assembly</b></p> <ul style="list-style-type: none"> <li>■ Rotate cam shaft such that the half lock washer will come up from the cylinder head slot.</li>   <li>■ Remove the half washer.</li>   <li>■ Rotate Cam shaft if necessary such that One hex bolt can be accessed for loosening.</li> <li>■ Straighten lock tab &amp; remove 1<sup>st</sup> hex bolt.</li> </ul>	<p><b>Hex bolt: M6 X 12 Hex Socket: 10mm</b></p>	  

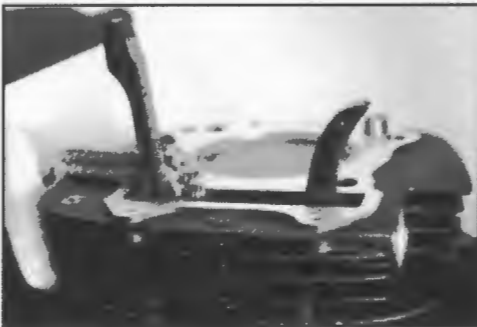

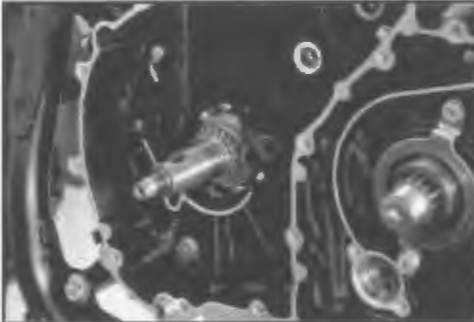
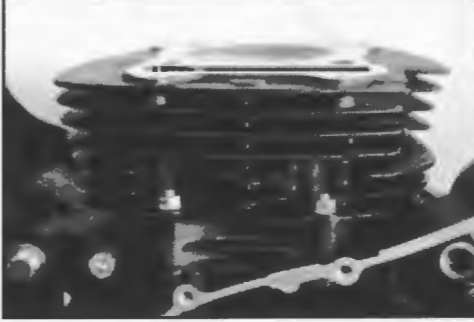

S. No.	Aggregate to Assemble / Instructions	Fastener, Size, Tool Usage, Precautions, Photos	
45.	<p><b>Cam shaft assembly</b></p> <ul style="list-style-type: none"> <li>■ Rotate Cam shaft to access the 2<sup>nd</sup> hex bolt.</li> <li>■ Straighten lock tab &amp; remove hex bolt, along with lock plate.</li> <li>■ Release sprocket from the dowel in cam shaft to increase chain slack.</li> <li>■ Release cam chain from the Sprocket by lifting and pushing it behind the sprocket.</li> <li>■ Lift cam shaft and remove sprocket.</li> <li>■ Remove cam shaft.</li> </ul>	<p><b>CAUTION:</b></p> <p>Ensure the Lock tab and washer does not drop into the cam chain</p>	
		<p><b>NOTE:</b></p> <p>Hold chain securely, to prevent it from dropping into cylinder head.</p>	

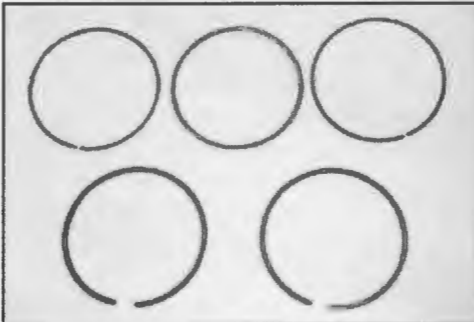

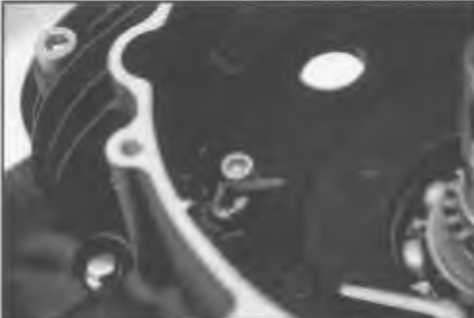

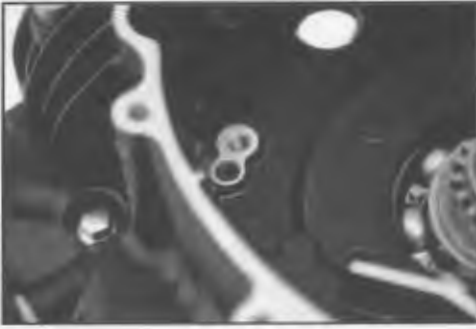

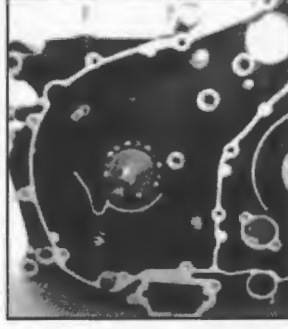



S. No.	Aggregate to Assemble / Instructions	Fastener, Size, Tool Usage, Precautions, Photos	
48.	<p><b>Valves in Cylinder Head</b></p> <ul style="list-style-type: none"> <li>■ Locate valve spring compressor tool on inlet valve such that the sleeve with screw is resting on the retainer valve spring &amp; the bottom of the tool is centrally located on the valve.</li> <li>■ Tighten special tool till springs are compressed fully &amp; the cotters are free from the valve stem.</li> <li>■ Remove both cotters &amp; loosen special tool till springs are fully expanded &amp; tool can be easily removed.</li> <li>■ Remove special tool, retainer, outer spring, inner spring &amp; spring seat from the cylinder head.</li> <li>■ Remove inlet valve by pulling it from bottom of cylinder head.</li> <li>■ Remove Valve stem seals from the valve guide top.</li> <li>■ Repeat above procedure to dismantle exhaust valve.</li> </ul>	<p><b>Special Tool: ST-27528-2 Valve Spring Compressor Tool</b></p> <p><b>CAUTION:</b> Ensure special tool is correctly located before attempting to compress valve springs.</p> <p><b>NOTE:</b> Ensuresplit collars are removed before releasing springs</p> <p><b>NOTE:</b> The valve guides &amp; valve seat inserts should not be removed from cylinder head OR reworked as it will affect engine performance.  In the event of any wear out, complete cylinder head assy. should only be replaced</p>	  
49.	<p><b>Chain guide pads</b></p> <ul style="list-style-type: none"> <li>■ Remove chain guide pad located in the front on the cylinder head, by pulling it from the top.</li> </ul>		



S. No.	Aggregate to Assemble / Instructions	Fastener, Size, Tool Usage, Precautions, Photos	
49.	<p><b>Chain guide pads</b></p> <ul style="list-style-type: none"> <li>■ Release the cam chain from the sprocket on crankshaft and remove from the engine.</li> <li>■ Remove Bolt- Stepped, holding chain tensioner pad to crankcase LH.</li> <li>■ Remove fixed chain guide pad from the top.</li> </ul>	<p><b>Bolt Stepped: M6 X 14 Allen Key: 5</b></p> <p><b>CAUTION:</b> Take care to remove the washer behind the chain tensioner pad.</p>	 
50.	<p><b>Cylinder barrel assembly</b></p> <ul style="list-style-type: none"> <li>■ Remove 2 hex flange nuts on LH side of cylinder barrel.</li> <li>■ Gently lift cylinder barrel up to remove from piston.</li> <li>■ Remove cylinder base gasket.</li> <li>■ Locate special tool on connecting rod below piston on inlet side, to support piston</li> </ul>	<p><b>Hex flange nut: M6 Double end spanner: 8mm</b></p> <p><b>NOTE:</b> Ensure the 2 dowels are removed from crankcase LH. / cylinder barrel</p> <p><b>Special Tool: ST-27529-2 Piston support special tool.</b></p>	 





S. No.	Aggregate to Assemble / Instructions	Fastener, Size, Tool Usage, Precautions, Photos	
51.	<p><b>Piston Pin</b></p> <ul style="list-style-type: none"> <li>■ Remove circlip from one side of piston &amp; push out gudgeon pin from opposite side.</li> <li>■ Remove Piston from Connecting rod</li> </ul>	<p><b>Special Tool: ST-27529-2</b> <b>Piston support special tool.</b></p>	
52.	<p><b>Piston rings</b></p> <ul style="list-style-type: none"> <li>■ Remove piston rings by expanding the rings at their open ends slightly &amp; lifting towards the top of the piston.</li> </ul>	<p><b>NOTE:</b></p> <p>Do not expand rings too much since they will break!</p> <p>The oil control ring is a 3 piece set.</p>	
53.	<p><b>Oil Jet Cylinder barrel seating area</b></p> <ul style="list-style-type: none"> <li>■ Remove oil jet from RH Crankcase / barrel seating area.</li> </ul>		
54.	<p><b>Oil Jet - Crankcase LH (outside)</b></p> <ul style="list-style-type: none"> <li>■ Remove Hex socket head screw from Crankcase LH</li> </ul>	<p><b>Hex Socket Hd Screw: M6 X12</b> <b>Allen Key: M5</b></p>	

S. No.	Aggregate to Assemble / Instructions	Fastener, Size, Tool Usage, Precautions, Photos	
54.	<p><b>Oil Jet - Crankcase LH (outside)</b></p> <ul style="list-style-type: none"> <li>■ Gently pull out &amp; remove oil jet.</li> </ul>	<p><b>NOTE:</b></p> <p>Ensure the small 'O' ring is removed from seating area in crankcase / behind oil jet.</p>	
55.	<p><b>Crankcase Fasteners Remove</b></p> <ul style="list-style-type: none"> <li>■ Hex socket head screw from crankcase LH front.</li> <li>■ 3 hex bolts from crankcase LH magneto area.</li> <li>■ 1 Hex flange bolt from LH crankcase near starter motor housing.</li> </ul>	<p><b>Hex Socket Hd Screw: M6X12 Allen Key: M5.</b></p>	  
		<p><b>Hex bolt: M8 X 70 Hex Socket: 12mm</b></p>	
		<p><b>Hex bolt: M6 X 60 Hex Socket: 8mm</b></p>	
		<p><b>NOTE:</b></p> <p>8 Hex Bolts (1 near Starter motor housing, 4 in front &amp; 3 at bottom are shorter &amp; same length.)</p> <p>6 Hex bolts on rear end are the longest</p>	

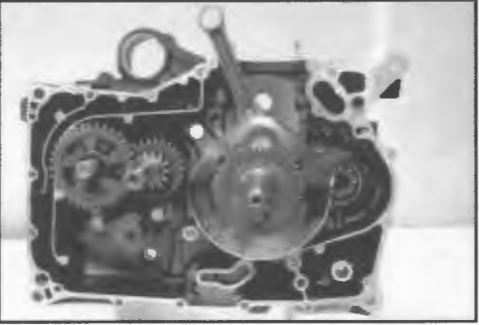
S. No.	Aggregate to Assemble / Instructions	Fastener, Size, Tool Usage, Precautions, Photos	
55.	<p><b>Crankcase Fasteners Remove</b></p> <ul style="list-style-type: none"> <li>■ 4 Hex flange bolts from LH crankcase front.</li>   <li>■ 6 Hex bolts (Longest) from LH crankcase rear.</li>   <li>■ 3 Hex bolts from crankcase LH bottom</li> </ul>	<p><b>Hex bolt: M6 X 60</b> <b>Hex Socket: 8mm</b></p>	
		<p><b>Hex Flange bolt: M6 X 85</b> <b>Hex Socket: 10mm</b></p>	
		<p><b>Hex bolt: M6 X 60</b> <b>Hex Socket: 8mm.</b></p>	
56.	<p><b>Crankcases splitting</b></p> <ul style="list-style-type: none"> <li>■ Split crankcases by locating 2 suitable short Hex bolts with nuts, between the front &amp; rear tabs on the crankcases.</li> <li>■ Unscrew nuts evenly such that the crankcases separate.</li> <li>■ Gently tap on the tabs using small plastic mallet to separate crankcases further.</li> </ul>		

S. No.	Aggregate to Assemble / Instructions	Fastener, Size, Tool Usage, Precautions, Photos
57.	<p><b>Crankcase RH removal</b></p> <ul style="list-style-type: none"> <li>Remove Crankcase RH from the shafts by gently tapping on the shafts simultaneously, using a small plastic mallet</li> </ul>	 <div data-bbox="594 772 915 947" style="border: 1px solid black; padding: 5px;"> <p><b>NOTE:</b> Please ensure thrust washer on counter shaft does not fall off</p> </div> 
58.	<p><b>Balancer shaft assembly</b></p> <ul style="list-style-type: none"> <li>Gently tap balancer shaft out of the bearing from the Crankcase LH.(Partial blind hole)</li> </ul>	<div data-bbox="594 1136 915 1339" style="border: 1px solid black; padding: 5px;"> <p><b>NOTE:</b> The gear has a high interference fit in balancer shaft and hence cannot be separated from the shaft.</p> </div> 
59.	<p><b>Crank shaft Assembly</b></p> <ul style="list-style-type: none"> <li>Remove crank shaft assembly by slightly rotating &amp; tapping from LH side (magneto side).</li> </ul>	<div data-bbox="594 1535 915 1776" style="border: 1px solid black; padding: 5px;"> <p><b>NOTE:</b> The LH shaft main bearing is integral with the crank shaft assembly, hence should NOT be removed or serviced separately.</p> </div> 

S. No.	Aggregate to Assemble / Instructions	Fastener, Size, Tool Usage, Precautions, Photos	
60.	<p><b>Oil Jet - crankcase LH (inside)</b></p> <ul style="list-style-type: none"> <li>■ Remove Hex socket head screw from Crankcase LH.</li>   <li>■ Gently pull out &amp; remove oil jet.</li> </ul>	<div data-bbox="597 401 919 510" style="border: 1px solid black; padding: 5px;"> <p><b>Hex Socket Head Screw: M6X12 Allen Key: M5</b></p> </div> <div data-bbox="597 772 919 947" style="border: 1px solid black; padding: 5px;"> <p><b>NOTE:</b> Ensure the small 'O' ring is removed from seating area in crankcase / behind oil jet.</p> </div>	<div data-bbox="1127 390 1414 711" style="border: 1px solid black; width: 100%; height: 100%; text-align: center;">  </div> <div data-bbox="1127 768 1414 1089" style="border: 1px solid black; width: 100%; height: 100%; text-align: center;">  </div>
61.	<p><b>Gear Operator Forks</b></p> <ul style="list-style-type: none"> <li>■ Remove the 2 spindles holding the operator forks to the gear drum assembly.</li>   <li>■ Remove three operator forks from the gears.</li> </ul>	<div data-bbox="597 1535 919 1839" style="border: 1px solid black; padding: 5px;"> <p><b>NOTE:</b> Both the long operator forks are located towards the rear end of crank case &amp; the small operator fork at the center.  The forks are numbered 1, 2 &amp; 3 for easy identification.</p> </div>	<div data-bbox="1127 1142 1414 1463" style="border: 1px solid black; width: 100%; height: 100%; text-align: center;">  </div> <div data-bbox="938 1528 1414 1850" style="border: 1px solid black; width: 100%; height: 100%; text-align: center;">  </div>

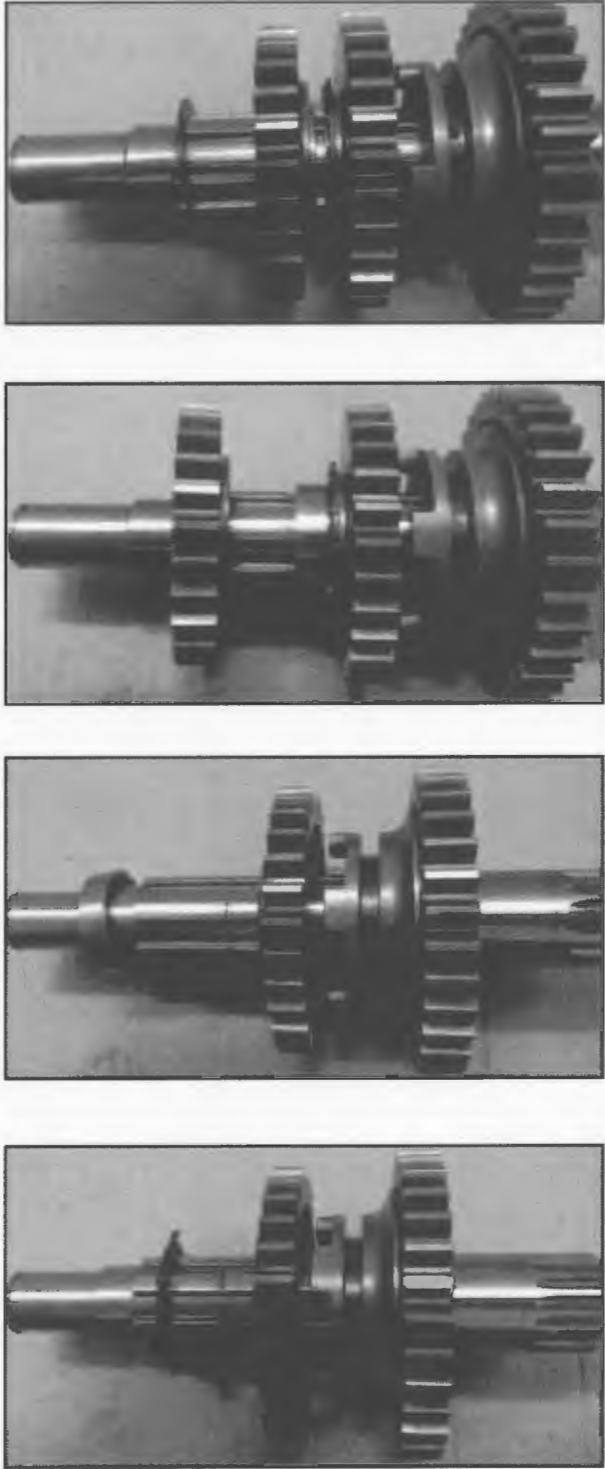

S. No.	Aggregate to Assemble / Instructions	Fastener, Size, Tool Usage, Precautions, Photos
62.	<p><b>Gear shifter drum</b></p> <ul style="list-style-type: none"> <li>■ Remove gear shifter drum from crankcase LH</li> </ul>	
63.	<p><b>Drive shaft assembly</b></p> <ul style="list-style-type: none"> <li>■ Remove thrust washer</li>   <li>■ Remove 1<sup>st</sup> gear with floating bush.</li>   <li>■ Remove thrust washer</li> </ul>	  

S. No.	Aggregate to Assemble / Instructions	Fastener, Size, Tool Usage, Precautions, Photos
63.	<p><b>Drive shaft assembly</b></p> <ul style="list-style-type: none"> <li>■ Remove 5<sup>th</sup> gear.</li>   <li>■ Gently tap drive shaft from the LH side &amp; remove from crankcase LH.</li>   <li>■ Remove drive shaft spacer from crankcase LH outside.</li> </ul>	<div data-bbox="1123 394 1409 716" data-label="Image"> </div> <div data-bbox="597 779 917 1142" data-label="Text"> <p><b>Caution:</b></p> <p>The bush will be tight on drive shaft, due to the 'O' ring inside the bush.</p> <p>Gently tap the shaft to remove from crankcase LH.</p> <p>Take care not to damage the threads while tapping on the shaft.</p> </div> <div data-bbox="1123 772 1409 1094" data-label="Image"> </div> <div data-bbox="933 1144 1409 1465" data-label="Image"> </div>
64.	<p><b>Gears in drive shaft</b></p> <ul style="list-style-type: none"> <li>■ Remove circlip.</li> </ul>	<div data-bbox="597 1543 917 1583" data-label="Text"> <p><b>External circlip pliers</b></p> </div> <div data-bbox="933 1528 1409 1745" data-label="Image"> </div>

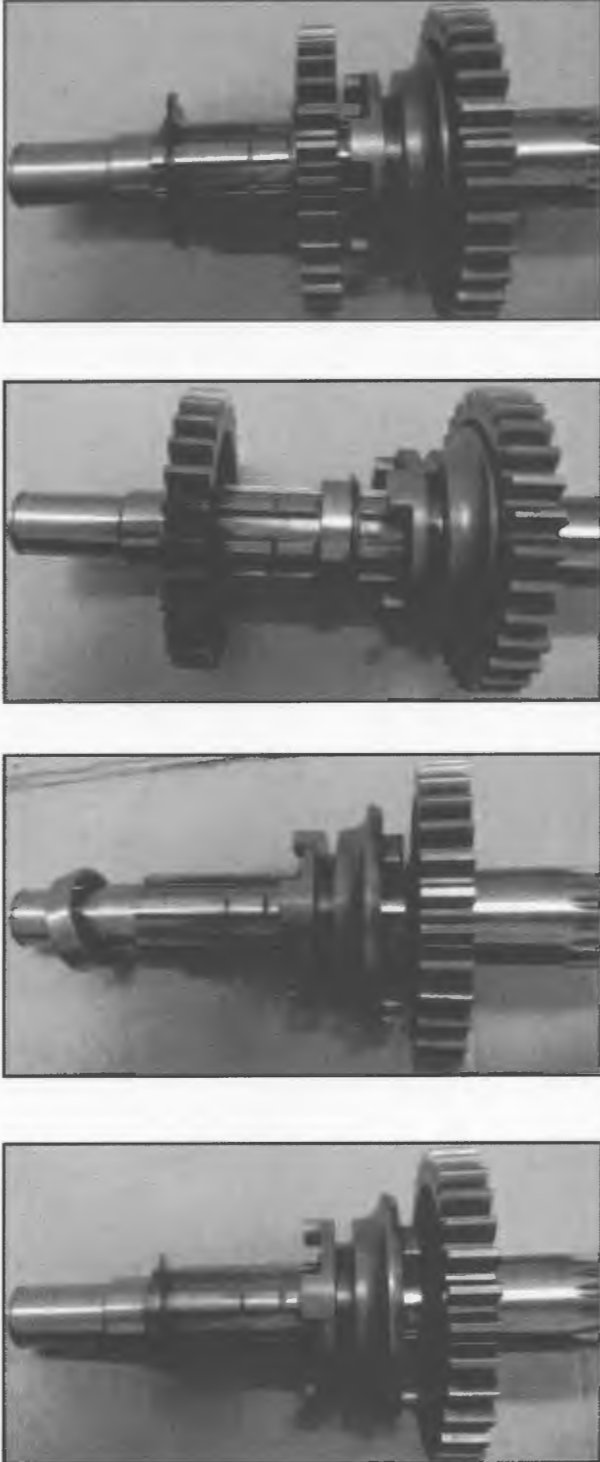

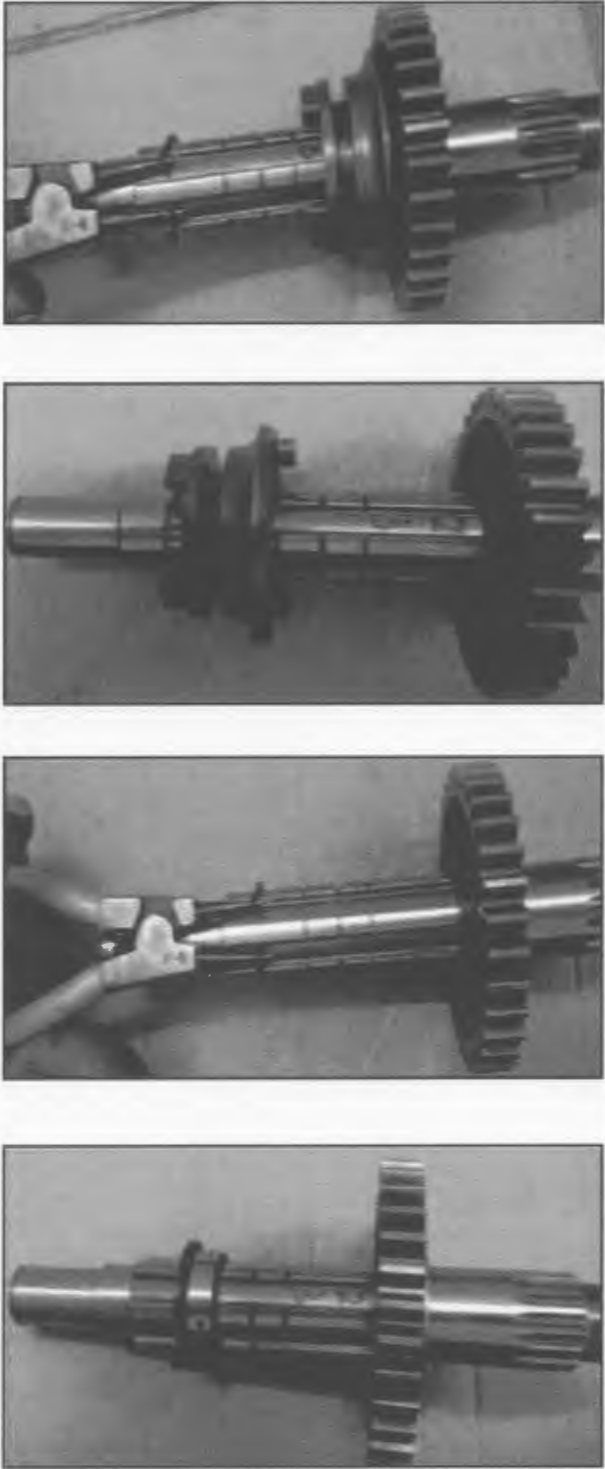

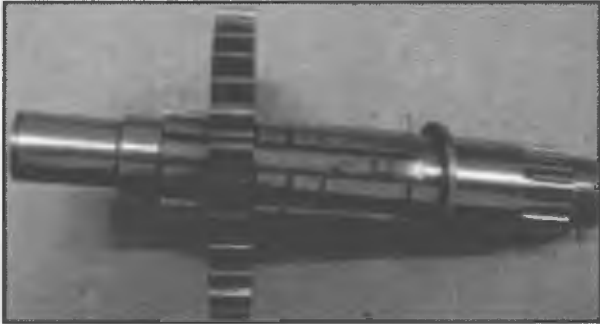
S. No.	Aggregate to Assemble / Instructions	Fastener, Size, Tool Usage, Precautions, Photos
64.	<p><b>Gears in drive shaft</b></p> <ul style="list-style-type: none"> <li>■ Remove thrust washer with 3 lugs.</li>   <li>■ Remove 4<sup>th</sup> gear</li>   <li>■ Remove bush with internal splines.</li>   <li>■ Remove splined washer with outside tabs.</li> </ul>	

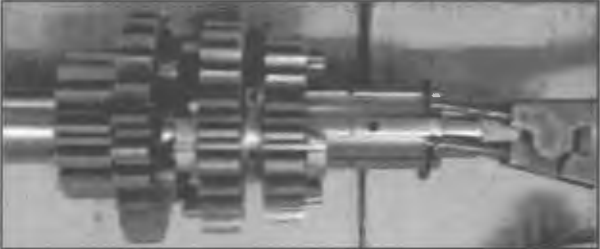

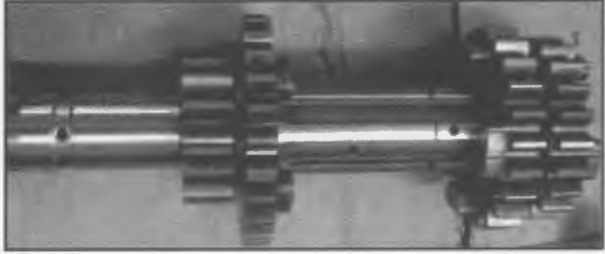
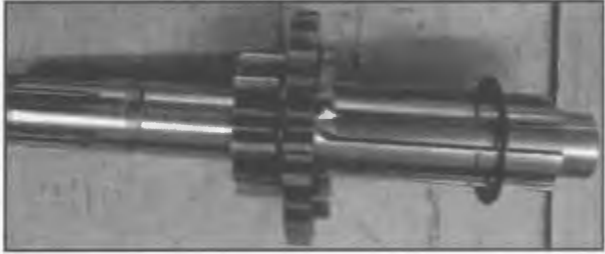
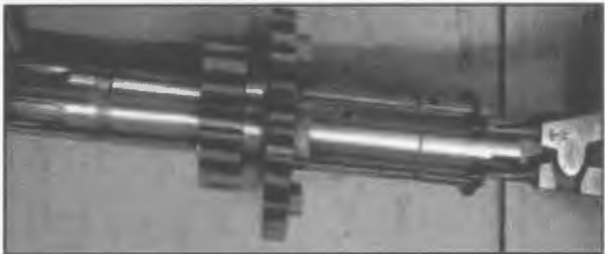
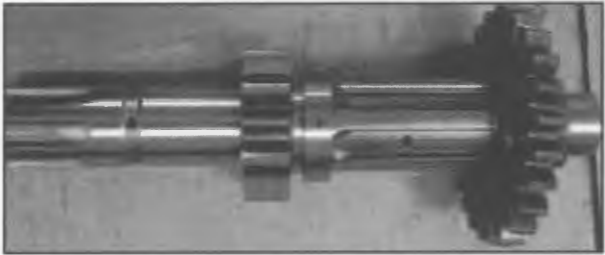

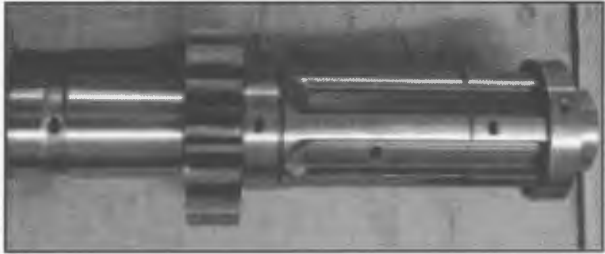
S. No.	Aggregate to Assemble / Instructions	Fastener, Size, Tool Usage, Precautions, Photos
64.	<p><b>Gears in drive shaft</b></p> <ul style="list-style-type: none"> <li>■ Rotate thrust washer with internal splines such that the splines are free to move in the shaft &amp; remove washer from shaft.</li>   <li>■ Remove 3<sup>rd</sup> gear.</li>   <li>■ Remove splined bush.</li>   <li>■ Remove thrust washer.</li> </ul>	





S. No.	Aggregate to Assemble / Instructions	Fastener, Size, Tool Usage, Precautions, Photos	
64.	<p><b>Gears in drive shaft</b></p> <ul style="list-style-type: none"> <li>■ Remove circlip.</li>   <li>■ Remove sliding bush.</li>   <li>■ Remove circlip</li>   <li>■ Remove collared bush.</li> </ul>	<div data-bbox="597 401 760 485" style="border: 1px solid black; padding: 2px;"> <p><b>External circlip pliers</b></p> </div>	

S. No.	Aggregate to Assemble / Instructions	Fastener, Size, Tool Usage, Precautions, Photos
64.	<b>Gears in drive shaft</b> <ul style="list-style-type: none"> <li>■ Remove 2<sup>nd</sup> gear.</li> </ul>	
65.	<b>Counter shaft assembly</b> <ul style="list-style-type: none"> <li>■ Pull out main shaft with gears from crankcase LH.</li> </ul>	<div data-bbox="597 779 919 968" style="border: 1px solid black; padding: 5px;"> <b>CAUTION:</b>            Ensure thrust washer on main shaft does not get misplaced while removing main shaft         </div> 
66.	<b>Gears in counter shaft</b> <ul style="list-style-type: none"> <li>■ Remove 2<sup>nd</sup> gear.</li> <li>■ Remove circlip.</li> </ul>	 <div data-bbox="597 1528 794 1619" style="border: 1px solid black; padding: 5px;"> <b>External circlip pliers</b> </div> 

S. No.	Aggregate to Assemble / Instructions	Fastener, Size, Tool Usage, Precautions, Photos
66.	<p><b>Gears in counter shaft</b></p> <ul style="list-style-type: none"> <li>■ Remove 3<sup>rd</sup> &amp; 4<sup>th</sup> sliding gears.</li>   <li>■ Remove thrust washer.</li>   <li>■ Remove circlip.</li>   <li>■ Remove 5<sup>th</sup> gear.</li> </ul>	<div style="display: flex; flex-direction: column; align-items: center;">       <div style="display: flex; align-items: center; margin: 10px 0;"> <div style="border: 1px solid black; padding: 2px 5px; margin-right: 10px;">External circlip pliers</div>  </div>    </div>

S. No.	Aggregate to Assemble / Instructions	Fastener, Size, Tool Usage, Precautions, Photos
66.	<p><b>Gears in counter shaft</b></p> <ul style="list-style-type: none"> <li>■ Remove bush.</li> </ul>	<p><b>NOTE:</b> 1<sup>st</sup> gear is integral with main shaft</p> 
67.	<p><b>Crankcase LH oil seals</b></p> <ul style="list-style-type: none"> <li>■ Open lock tabs and remove 2 Hex bolts along with lock plate from crankcase LH outer side.</li> <li>■ Remove drive shaft oil seal from the crankcase LH outer side.</li> <li>■ Remove gear shift shaft double lipped oil seal from crankcase LH outer side.</li> </ul>	<p><b>Hex bolt: M6 X 10</b> <b>Hex Socket: 10mm</b></p>   

S. No.	Aggregate to Assemble / Instructions	Fastener, Size, Tool Usage, Precautions, Photos	
68.	<p><b>Crankcase RH bearings</b></p> <p><b>A. Selector drum bearing:</b></p> <ul style="list-style-type: none"> <li>■ Remove 2 hex socket head screws with retainer plates from crankcase RH outer side.</li> <li>■ Using a suitable drift, drive out the ball bearing from the inner side of crankcase RH.</li> </ul> <p><b>B. Drive shaft bearing:</b></p> <ul style="list-style-type: none"> <li>■ Using a suitable drift, drive out the ball bearing from the outer side of crankcase RH.</li> </ul> <p><b>C. Counter shaft bearing:</b></p> <ul style="list-style-type: none"> <li>■ Remove hex socket head screw along with retainer plate from the inner side of crankcase RH.</li> <li>■ Using a suitable drift, drive out the ball bearing from the outer side of crankcase RH.</li> </ul> <p><b>D. Crankshaft bearing:</b></p> <ul style="list-style-type: none"> <li>■ Using a suitable drift, drive out the ball bearing from the outer side of crankcase RH.</li> </ul>	<p><b>Hex Socket Hd. Screw: M6 X 12 Allen Key: M5</b></p>	
		<p><b>Bearing drift &amp; plastic mallet.</b></p>	
		<p><b>Hex Socket Head Screw: M6 X 12 Allen Key: M5</b></p>	
		<p><b>Bearing drift &amp; plastic mallet.</b></p>	

S. No.	Aggregate to Assemble / Instructions	Fastener, Size, Tool Usage, Precautions, Photos	
68.	<p><b>Crankcase RH bearings</b></p> <p><b>E. Balancer shaft bearing:</b></p> <ul style="list-style-type: none"> <li>■ Use a suitable drift to drive the ball bearing out from the outer side of crankcase RH.</li> </ul>	<p>Bearing drift &amp; plastic mallet.</p>	
69.	<p><b>Crankcase LH bearings</b></p> <p><b>A. Drive shaft bearing:</b></p> <ul style="list-style-type: none"> <li>■ Using a suitable drift, drive out the ball bearing from the outer side of crankcase LH.</li> </ul> <p><b>B. Counter shaft bearing:</b></p> <ul style="list-style-type: none"> <li>■ Use a suitable two jaw puller to pull out the ball bearing from the blind hole inside crankcase LH.</li> </ul> <p><b>C. Balancer shaft bearing:</b></p> <ul style="list-style-type: none"> <li>■ Using a suitable drift, drive out the ball bearing from the outer side of crankcase LH.</li> </ul>	<p>Bearing drift &amp; plastic mallet.</p>	  

# WEAR LIMITS - LS 410

New components must be within the limits specified. Components within service limits may be reused after careful inspection. Use of parts beyond service limit can reduce the operating life of the component and affect the motorcycle performance seriously.

(All units in mm unless specified)

Component	Where / What to Measure	Minimum	Maximum	Service Limit
Cylinder Bore ID	Top, Middle & Bottom of Piston working area	78.000	78.030	78.100
Piston OD	Top, Middle & Bottom of piston	77.940	77.970	77.870
Cylinder Bore/Piston	Clearance	0.015	0.040	0.20
Piston ring top 1	Rings End Gap in Bore at the topmost ring working area in bore.	0.15	0.30	0.60
Piston ring top 2		0.20	0.40	0.70
Top ring	Clearance between Piston ring groove & piston rings in assembled condition	0.03	0.07	0.10
Middle ring		0.03	0.07	0.10
Oil scrapper ring		0.03	0.07	0.10
Balancer Shaft	Run out	-	0.03	0.05
Crankshaft Assembly	Crankshaft assembly run out	-	0.05	0.09
Crankshaft Assembly	Big End Axial Play	-	-	0.065
Piston Pin	Piston Pin Diameter	19.992	19.997	19.977
Connecting rod	Connecting rod small end ID	20.010	20.019	20.050
Cylinder head / cover	Warpage	-	-	0.01
Cylinder head / barrel	Warpage	-	-	0.01
Valve guide Inlet	Internal ID	7.000	7.015	7.070
Valve guide Exhaust		7.000	7.015	7.100
Valve stem Inlet	Stem OD	6.960	6.975	6.945
Valve stem Exhaust		6.945	6.960	6.920
Valve / Guide Inlet	Valve stem to Guide Clearance			0.01
Valve / Guide Exhaust				0.14
Valve seat/valve	Contact area		1.00	1.50
Valve Spring Inner	Overall Length	36.70		34.70
Valve Spring Outer		43.90		41.90
Cam shaft	Run out		0.02	0.05
Camshaft	Journal Dia	21.959	21.980	21.930
Camshaft	Journal Bore Dia	21.988	22.025	22.088
Camshaft Journal	Oil groove clearance	-	-	0.05
Cam Lobe	Lobe Height	36.92	36.96	36.76
Clutch Spring	Free Length		33.60	32.60
Clutch Steel Plate	Thickness	1.550	1.650	1.533
Clutch Friction Plate	Thickness	2.950	3.050	2.830
Clutch Steel/ Friction Plates	Distortion		0.10	0.30
Shifter Drum	Groove width	6.05	6.20	6.30
Shifter Forks	Guide Pin Dia	5.85	5.95	5.75
	Lug Thickness	5.30	5.40	5.20

# TORQUE VALUES - LS 410

Aggregate	Component	Fastener	Qty	Torque Range	
				(Nm)	(Kg. M)
Crankcase LH Side	Piston Oil Jet	Hex Socket Head Screw M6 X 12	1	8 - 12	0.8 - 1.2
	Starter Clutch Oil Jet	Hex Socket Head Screw M6 X 12	1	8 - 12	0.8 - 1.2
	Cam Chain Tensioner Pad	Bolt Stepped - M6 X 14	1	10 - 12	1.0 - 1.2
	Gear Position Switch	Hex Flange Bolt - M6 X 16	2	6.8Max	0.68Max
	Oil Strainer Cap	Hex Flange Bolt - M6 X 20,	2	8 - 12	0.8 - 1.2
	Oil Passage	Hex Flange Bolt - M8 X 12	3	20 - 24	2.0 - 2.4
	Crankcase Drain	Plug M14 X 12	1	20 - 25	2.0 - 2.5
	Drive Shaft Oil Seal Retainer	Hex Bolt - M6 X 10	2	8 - 12	0.8 - 1.2
	Final Drive Sprocket	Hex Nut M20	1	130 - 160	13 - 16
	Sprocket Cover	Hex Flange Bolt - M6 X 35	2	8 - 12	0.8 - 1.2
Magneto	Rotor Ring Assembly	Hex Socket Head Screw M6X20	6	10 - 12	1.0 - 1.2
	Magneto Rotor	Hex Flange Nut M12 X1.25 X 11	1	70 - 80	70 - 8.0
Cover LH	Clamp, Stator Wire	Hex Socket Head Screw M5 X 15	2	8 - 10	0.8 - 1.0
	Stator Coil Screw	Hex Socket Head Screw M5 X 30	3	8 - 10	0.8 - 1.0
	TDC Inspection Plug	Plug - M14 X 12	1	20 - 25	2.0 - 2.5
	Cover LH Mounting	Hex Flange Bolt - M6 X 35	8	8 - 12	0.8 - 1.2
		Hex Flange Bolt - M6 X 55	3	8 - 12	0.8 - 1.2
	Cover LH Logo	Hex Socket Head Screw M6 X 21	2	8 - 12	0.8 - 1.2
Crankcase LH & RH	Crankcase boxing	Hex Socket Head Screw M8X100	1	20 - 24	2.0 - 2.4
		Hex Flange Bolt - M8 X 70	3	20 - 24	2.0 - 2.4
		Hex Flange Bolt - M6 X 85	6	8 - 12	0.8 - 1.2
		Hex Flange Bolt - M6 X 60	8	8 - 12	0.8 - 1.2
	Starter Motor	Hex Flange Bolt - M6 X 30	2	10 - 12	1.0 - 1.2
Crankcase RH	Cam Drum Bearing Retainer	Hex Socket Head Screw M6 X 12	2	8 - 12	0.8 - 1.2
	Oil Pump	Hex Flange Bolt - M6 X 30	4	7 - 9	0.7 - 0.9
	Stopper, Gear Shift Arm	Hex Flange bolt M8	1	10 - 12	1.0 - 1.2
	Pump Drive Gear	Nut (LH Thread) M18	1	85 - 90	8.5 - 9.0
	Balancer Shaft	Hex Flange Bolt - M10 X 20	1	40 - 60	4.0 - 6.0
	Clutch Center	Hex Nut M20	1	40 - 60	4.0 - 6.0
Gear shifting	Star Index	Hex Socket Head, Stepped Bolt	1	10 - 12	1.0 - 1.2
	Gear Shift Cam Stopper	Hex Bolt Stepped	1	10 - 12	1.0 - 1.2

Aggregate	Component	Fastener	Qty	Torque Range		
				(Nm)	(Kg. M)	
Cover RH	Cover Oil Jet Seal Retainer	Hex Socket Head Screw M6 X 12	1	8-12	0.8-1.2	
	Clutch shaft spring.	Hex Flanged Bolt- M6 X 10	1	10-12	1.0-1.2	
	Cover RH	Hex Flange Bolt - M6 X 37	8	8-12	0.8-1.2	
			Hex Flange Bolt M6 X 30	5	8-12	0.8-1.2
			Hex Flange Bolt - M6 X 20	1	8-12	0.8-1.2
	Cap - Oil Filter	Hex Flange Bolt - M6 X 70	1	8-12	0.8-1.2	
		Hex Flange Bolt - M6 X 20	2	8-12	0.8-1.2	
Plug, Oil Check	Plug- M14 X 12	1	20-25	2.0-2.5		
Cylinder Head	Cylinder Head	Special Hex Bolts - M10 X 170	4	40-45	4.0-4.5	
	Camshaft & Sprocket Lock	Hex Bolt - M6 X 12	2	10-12	1.0-1.2	
	Cylinder Head Side Mount	Hex Flange Bolt - M6 X	2	8-12	0.8-1.2	
	De Compressor Fly Weight	Hex Socket Head Screw	1	3-5	0.3-0.5	
	PAV Pipe Mounting	Hex Socket Head Screw M X	2	8-12	0.8-1.2	
	Spark Plug	Spark Plug (M10) - CR8E	1	10-15	1.0-1.5	
	Adapter Carb To Cyl Head	Hex Socket Head Screw- M6	2	8-12	0.8-1.2	
Cylinder Barrel	Cylinder barrel side Mount	Hex Flange Nut M6 X 1	2	8-12	0.8-1.2	
	Auto Chain Tensioner Mtg & Spring bolt	Hex Socket Head Screw M6 X 25	2	10-12	1.0-1.2	
		Special Hex Bolt M 8	1	8-10	0.8-1.0	
Cylinder Head Cover	Cylinder Head Cover	Hex Flange Bolt - M6 X 60	5	10-14	1.0-1.4	
		Hex Flange Bolt - M6 X 55	3	10-14	1.0-1.4	
		Hex Flange Bolt - M6 X 45	1	10-14	1.0-1.4	
		Hex Flange Bolt - M6 X 40	1	8-12	0.8-1.2	
		Hex Flange Bolt - M6 X 20	6	8-12	0.8-1.2	
		Hex Flange Bolt - M6 X 21	2	8-12	0.8-1.2	
	Tappet Cover	Hex Flange Bolt-M6 X 21	4	8-12	0.8-1.2	
Plug, Camshaft Hole	Hex Flange Bolt - M6 X 16	1	8-12	0.8-1.2		
Cam Cover	Rocker Shaft Plugs	Hex Socket Head Plug-M14 X 12	2	25-30	2.5-3.0	
	Cover- Cam Center	Hex Flange Bolt - M6 X 16	2	8-12	0.8-1.2	
Oil Cooler	Oil Cooler Pipe banjo	Bolt, Union M	2	35-38	3.5-3.8	
	Oil Cooler pipe Mtg	Hex Socket Head Screw M	4	8-12	0.8-1.2	

## **PRECAUTIONS BEFORE ENGINE REASSEMBLY**



---





- Please ensure all parts are thoroughly cleaned and stored in a sequence for inspection and reassembly.
- Lubricate all moving parts prior to reassembly.
- Replace parts like: Gaskets, "O" Rings, Oil seals, Dust seals, Rubber items, Aluminum washers, Circlips whenever they are removed OR during a complete engine overhaul.





### **NOTE:**



While fixing bearings, bushes or oil seals, it is NOT necessary to heat the Crankcase.



# ENGINE ASSEMBLY SEQUENCE





S. No.	Aggregate to Assemble / Instructions	Fastener, Size, Tool Usage, Precautions, Photos
1.	<p><b>Crankcase LH Bearings</b></p> <p><b>A. Balancer shaft Bearing:-</b></p> <ul style="list-style-type: none"> <li>■ Locate bearing in Crankcase LH from innerside &amp; gently tap using a suitable drift and plastic mallet</li> </ul> <p><b>B. Counter shaft bearing:</b></p> <ul style="list-style-type: none"> <li>■ Locate bearing in the blind hole in Crankcase LH from inner side &amp; gently tap using a suitable drift and plastic mallet</li> </ul> <p><b>C. Drive shaft bearing:</b></p> <ul style="list-style-type: none"> <li>■ Locate bearing in Crankcase LH from innerside &amp; gently tap using a suitable drift and plastic mallet</li> </ul>	<div data-bbox="594 394 919 478" style="border: 1px solid black; padding: 5px; margin-bottom: 10px;">                     Bearing drift &amp; plastic mallet.                 </div> <div data-bbox="1068 386 1404 793" style="text-align: right;">  </div> <div data-bbox="594 905 919 1100" style="border: 1px solid black; padding: 5px; margin-top: 10px;"> <p><b>NOTE:</b></p> <p>Ensure bearing outer race is flush with housing in crank case after pressing the bearings.</p> </div> <div data-bbox="1068 898 1404 1306" style="text-align: right;">  </div> <div data-bbox="1068 1440 1404 1848" style="text-align: right;">  </div>



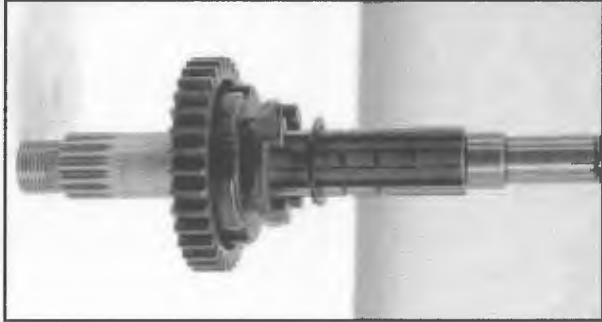

S. No.	Aggregate to Assemble / Instructions	Fastener, Size, Tool Usage, Precautions, Photos	
2.	<p><b>Crankcase RH Bearings</b></p> <p><b>A. Balancer shaft bearing:</b></p> <ul style="list-style-type: none"> <li>Locate bearing in crankcase RH from inner side &amp; gently tap using a suitable drift and plastic mallet.</li> </ul> <p><b>B. Crankshaft bearing:</b></p> <ul style="list-style-type: none"> <li>Locate bearing in crankcase RH from inner side &amp; gently tap using a suitable drift and plastic mallet.</li> </ul> <p><b>C. Counter Shaft Bearing:</b></p> <ul style="list-style-type: none"> <li>Locate bearing in crankcase RH from inner side &amp; gently tap using a suitable drift and plastic mallet.</li> </ul> <ul style="list-style-type: none"> <li>Position retainer plate between the slots in crankcase RH &amp; tighten with Hex Socket Head screw.</li> </ul>	<p>Bearing drift &amp; plastic mallet.</p> <p><b>NOTE:</b> Ensure bearing outer race is flush with housing in crank case after pressing the bearings.</p> <p><b>Hex socket hd. screw: M6X12 Allen Key: 5mm Torque: 0.8-1.2Kg.M (8-12 Nm)</b></p> <p><b>NOTE:</b> Ensure retainer plate is properly located over bearing outer race, before tightening screw.</p>	   

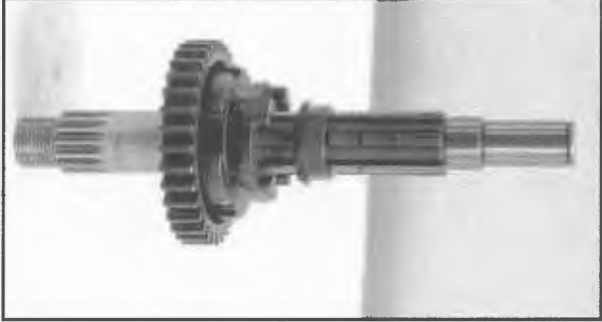
S. No.	Aggregate to Assemble / Instructions	Fastener, Size, Tool Usage, Precautions, Photos	
2.	<p><b>Crankcase RH Bearings</b></p> <p><b>D. Drive Shaft Bearing:</b></p> <ul style="list-style-type: none"> <li>Locate bearing in crankcase RH from inner side &amp; gently tap using a suitable drift and plastic mallet.</li> </ul> <p><b>E. Gear selector drum bearing.</b></p> <ul style="list-style-type: none"> <li>Locate bearing in Crankcase RH from outer side &amp; gently tap using a suitable drift and plastic mallet.</li> </ul> <ul style="list-style-type: none"> <li>Position two retainer plates between the slots in crankcase RH &amp; tighten with Hex Socket Head screws.</li> </ul>	    	<p data-bbox="597 779 919 856">Bearing drift &amp; plastic mallet.</p> <p data-bbox="597 1150 919 1289"><b>Hex socket head screw: M6X12</b> <b>Allen Key: 5mm</b> <b>Torque: 0.8-1.2 Kg.M (8-12 Nm)</b></p> <p data-bbox="597 1304 919 1493"><b>NOTE:</b> Ensure retainer plate is properly located over bearing outer race, before tightening screw.</p>
3.	<p><b>Crankcase LH Oil seals</b></p> <p><b>A. Gear shift shaft oil seal.</b></p> <ul style="list-style-type: none"> <li>Locate double lip oil seal in Crankcase LH from outer side &amp; gently tap using a suitable drift and plastic mallet.</li> </ul>		<p data-bbox="597 1535 919 1612">Bearing drift &amp; plastic mallet.</p> <p data-bbox="597 1640 919 1801"><b>NOTE:</b> Ensure oil seal outer face is facing outside &amp; is flush with housing in crank case.</p>

S. No.	Aggregate to Assemble / Instructions	Fastener, Size, Tool Usage, Precautions, Photos	
3.	<p><b>Crankcase LH Oil seals</b></p> <p><b>B. Drive shaft oil seal:</b></p> <ul style="list-style-type: none"> <li>■ Locate oil seal on crankcase LH from outer side &amp; gently tap using a suitable drift and plastic mallet.</li> <li>■ Locate retainer plate over oil seal &amp; tighten in position with 2 Hex bolts.</li> <li>■ Bend the retainer plate lock tabs over the hex bolts, to prevent them from loosening</li> </ul>	<p><b>NOTE:</b></p> <p>Ensure oil seal outer face is facing outside &amp; is flush with housing in crank case.</p>	
4.	<p><b>Piston Oil Jet</b></p> <ul style="list-style-type: none"> <li>■ Locate 'O' ring in crankcase LH inside.</li>   <li>■ Locate oil jet in crankcase LH inside with its spout facing upwards</li>   <li>■ Tighten with Hex Socket Head screw.</li> </ul>	<p><b>NOTE:</b></p> <p>Apply grease on 'O' ring to hold it in place.</p>	
		<p><b>Hex Bolt: M6 X 10</b>  <b>Hex Socket spanner: 8mm</b>  <b>Torque: 0.8-1.2Kg.M (8-12Nm)</b></p>	
		<p><b>Hex Socket Hd Screw: M6 X 12</b>  <b>Allen key: 5mm</b>  <b>Torque: 0.8-1.2Kg M (8-12Nm)</b></p>	

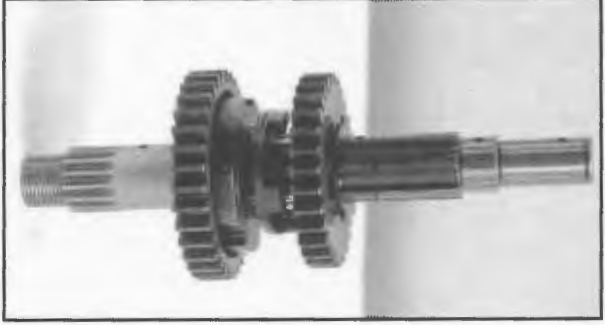

5. No.	Aggregate to Assemble / Instructions	Fastener, Size, Tool Usage, Precautions, Photos
5.	<p><b>Starter Clutch Oil Jet.</b></p> <ul style="list-style-type: none"> <li>■ Locate 'O' ring in Crank-case LH outside.</li>   <li>■ Locate oil jet in Crank-case LH outside with its spoutfacing downwards.</li>   <li>■ Tighten with Hex Socket Head screw.</li> </ul>	<p><b>NOTE:</b> Apply grease on 'O' ring to hold it in place.</p> <p><b>Hex Socket Hd Screw: M6 X 12 Allen key: 5mm Torque: 0.8-1.2KgM (8-12Nm)</b></p> 
6.	<p><b>Sub Assembly of gears in Drive Shaft</b></p> <ul style="list-style-type: none"> <li>■ Insert 2<sup>nd</sup> gear on the shaft such that the small recess in the machined side of the gear is seated on the collar of the shaft.</li> </ul>	



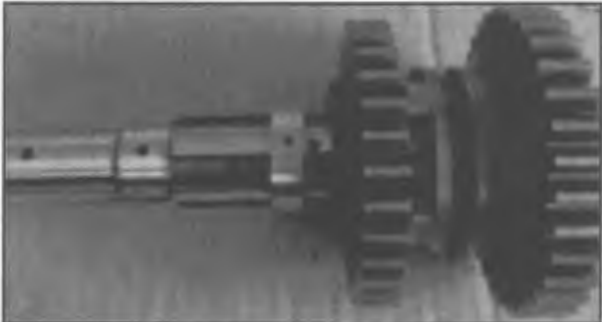
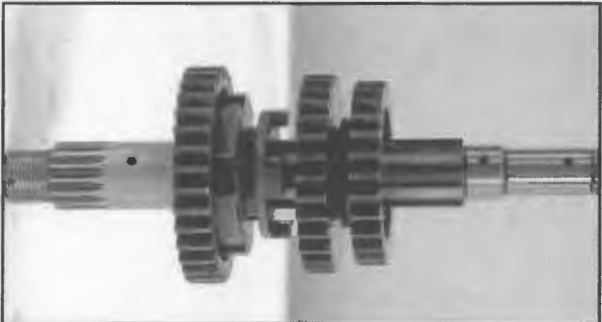
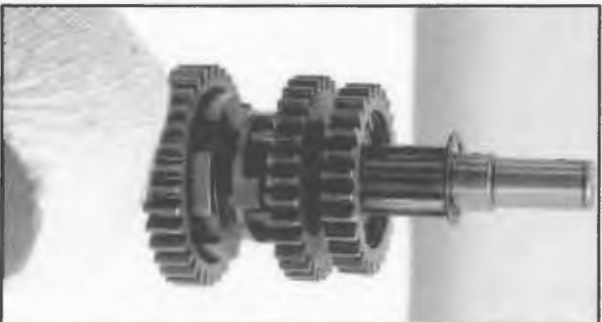

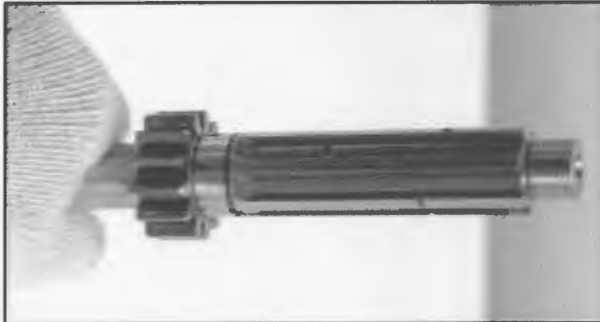
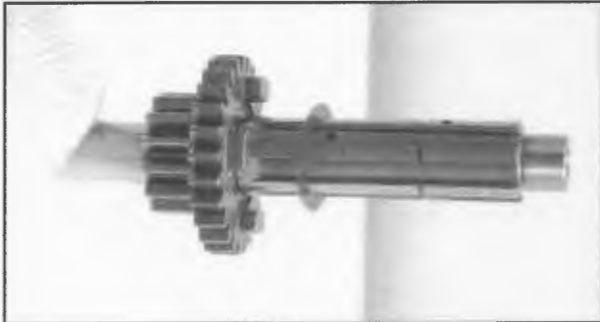
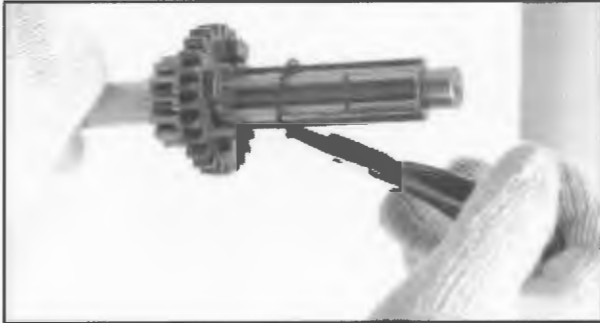
S. No.	Aggregate to Assemble / Instructions	Fastener, Size, Tool Usage, Precautions, Photos
6.	<p><b>Sub Assembly of gears in Drive Shaft</b></p> <ul style="list-style-type: none"> <li>■ Insert collared bush on the shaft, such that the bush will enter into the gear and the collar is facing outside and seated flush with the gear.</li>   <li>■ Assemble 1<sup>st</sup> circlip.</li>   <li>■ Insert bigger side of the sliding dog on the shaft, such that it is facing 2<sup>nd</sup> gear.</li>   <li>■ Assemble 2<sup>nd</sup> circlip.</li> </ul>	<div style="display: flex; flex-direction: column; align-items: center;">    <div style="border: 1px solid black; padding: 2px; margin: 5px;">Outside Circlip Plier</div>       <div style="border: 1px solid black; padding: 2px; margin: 5px;">Outside Circlip Plier</div>  </div>

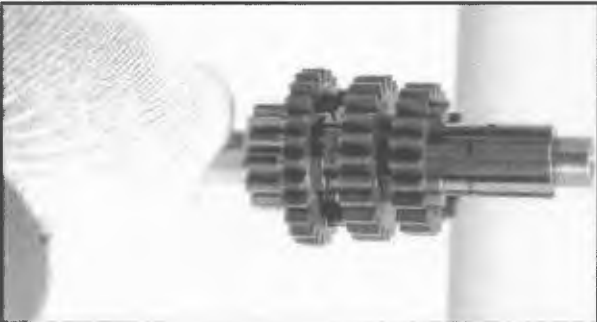
S. No.	Aggregate to Assemble / Instructions	Fastener, Size, Tool Usage, Precautions, Photos
6.	<p><b>Sub Assembly of gears in Drive shaft</b></p> <ul style="list-style-type: none"> <li>■ Assemble thrust washer with three internal splines on the shaft.</li>   <li>■ Align oil hole in the splined bush with the oil hole in shaft and lower it fully.</li>   <li>■ Assemble 3<sup>rd</sup> gear on the shaft with its slot facing the sliding dog.</li>   <li>■ Assemble thrust washer with internal and external splines on the shaft, align the internal tabs with the groove in shaft, just above the 3<sup>rd</sup> gear and rotate washer such that the washer locks in the shaft and cannot be removed.</li> </ul>	<p style="text-align: center;"><b>CAUTION:</b></p> <p style="text-align: center;">Ensure oil hole in bush is aligned with oil hole in shaft.</p>    







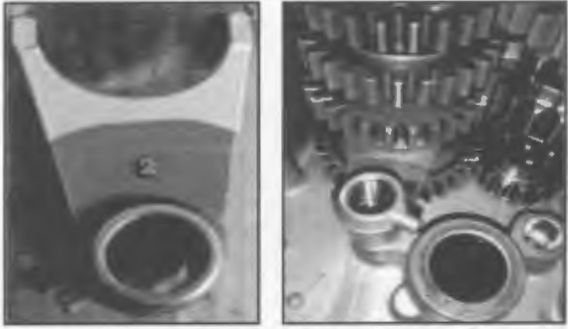

S. No.	Aggregate to Assemble / Instructions	Fastener, Size, Tool Usage, Precautions, Photos
6.	<p><b>Sub Assembly of gears in Drive Shaft</b></p> <ul style="list-style-type: none"> <li>■ Assemble thrust washer with outside tabs such that the tabs in the washer locks into the slots in the thrust washer.</li>   <li>■ Align oil hole in the splined bush with the oil hole in shaft and lower it fully.</li>   <li>■ Insert 4<sup>th</sup> gear on the shaft, with the slot in the gear facing outside and locate it on the splined bush.</li>   <li>■ Assemble 2<sup>nd</sup> thrust washer with the three internal splines.</li> </ul>	<p style="text-align: center;"><b>CAUTION:</b></p> <p style="text-align: center;">Ensure oil hole in bush is aligned with oil hole in shaft.</p>    



S. No.	Aggregate to Assemble / Instructions	Fastener, Size, Tool Usage, Precautions, Photos
6.	<p><b>Sub Assembly of gears in Drive shaft</b></p> <ul style="list-style-type: none"> <li>■ Assemble 3rd Circlip.</li> </ul>	<div data-bbox="597 401 760 485" style="border: 1px solid black; padding: 2px; width: fit-content;">           Outside Circlip plier         </div> 
7.	<p><b>Sub Assembly of gears in counter shaft</b></p> <ul style="list-style-type: none"> <li>■ Assemble bush on counter shaft, from the non-threaded end of the shaft.</li> <li>■ Assemble 5<sup>th</sup> gear such that the lugs of the gear are towards the non-threaded end of the counter shaft.</li> <li>■ Assemble 1st thrust washer.</li> </ul>	  





S. No.	Aggregate to Assemble / Instructions	Fastener, Size, Tool Usage, Precautions, Photos	
7.	<p><b>Sub Assembly of gears in counter shaft</b></p> <ul style="list-style-type: none"> <li>■ Assemble 1<sup>st</sup> circlip.</li>   <li>■ Assemble 3<sup>rd</sup> &amp; 4<sup>th</sup> sliding gear on the shaft such that the larger gear is facing the 5<sup>th</sup> gear.</li>   <li>■ Assemble 2<sup>nd</sup> circlip.</li>   <li>■ Assemble 2<sup>nd</sup> gear.</li> </ul>	<p>Outside Circlip plier</p>	
		<p><b>NOTE:</b> Larger gear must be towards the 1<sup>st</sup> gear.</p>	
		<p>Outside Circlip plier</p>	
		<p><b>NOTE:</b> Collar in the gear should face towards 1<sup>st</sup> gear.</p>	



S. No.	Aggregate to Assemble / Instructions	Fastener, Size, Tool Usage, Precautions, Photos	
8.	<p><b>Counter shaft thrust washer</b></p> <ul style="list-style-type: none"> <li>■ Place thrust washer over counter shaft bearing in CrankcaseLH.</li> </ul>	<p><b>NOTE:</b></p> <p>Apply grease on thrust washer to prevent it from falling off when locating main shaft.</p>	
9.	<p><b>Counter shaft &amp; Drive shaft in Crankcase LH</b></p> <ul style="list-style-type: none"> <li>■ Locate the shafts in their respective locations in CrankcaseLH, ensuring the gears in both shafts are aligned.</li> </ul>	<p><b>NOTE:</b></p> <p>Ensure threaded end of counter shaft is facing upwards &amp; threaded end of main shaft is inserted into Crankcase LH.</p> <p>Gently tap both shafts into bearings simultaneously for proper seating.</p>	
10.	<p><b>Sub Assembly of gears in Drive shaft</b></p> <ul style="list-style-type: none"> <li>■ Assemble 5<sup>th</sup> gear such that the gear side is facing towards 1<sup>st</sup> gear.</li> <li>■ Assemble thrust washer.</li> </ul>		 



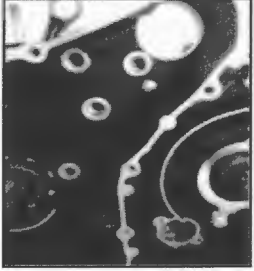

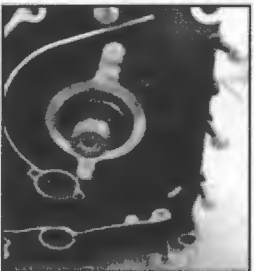
S. No.	Aggregate to Assemble / Instructions	Fastener, Size, Tool Usage, Precautions, Photos	
10.	<p><b>Sub Assembly of gears in Drive shaft</b></p> <ul style="list-style-type: none"> <li>■ Assemble 1<sup>st</sup> gear bush.</li>   <li>■ Assemble 1<sup>st</sup> gear over the bush such that the deep groove in 5<sup>th</sup> gear is facing towards 1<sup>st</sup> gear.</li>   <li>■ Assemble thrust washer over 1<sup>st</sup> gear</li> </ul>	<p><b>NOTE:</b> Ensure gears in both counter shaft &amp; drive shaft are aligned.</p>	
11	<p><b>Selector Forks</b></p> <ul style="list-style-type: none"> <li>■ Locate selector fork No.2, inside sliding dog of on drive shaft, with the fork lug facing above.</li> </ul>		

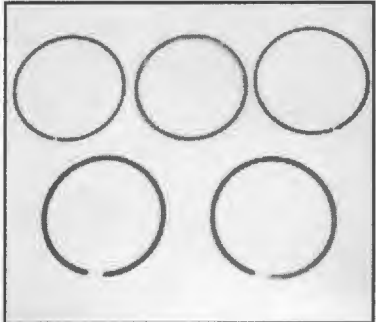



S. No.	Aggregate to Assemble / Instructions	Fastener, Size, Tool Usage, Precautions, Photos	
11.	<p><b>Selector Forks</b></p> <ul style="list-style-type: none"> <li>■ Locate operator fork No1 in the recess in drive shaft 5<sup>th</sup>gear.</li>   <li>■ Locate operator fork No.3 in counter shaft on 4<sup>th</sup>gear.</li> </ul>	 	 
12.	<p><b>Gear Shift Drum Assembly</b></p> <ul style="list-style-type: none"> <li>■ Insert long end of Shift Drum Assembly into Crankcase LH. (thetwo offset pegs in the drum assy must be facing outside.)</li>   <li>■ Lock selector forks in position by locating the spindles in Crankcase LH.</li> </ul>	 	 

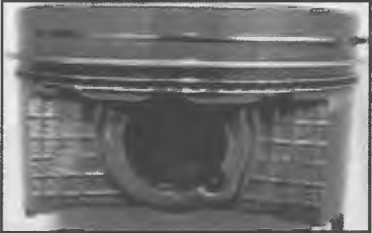



S. No.	Aggregate to Assemble / Instructions	Fastener, Size, Tool Usage, Precautions, Photos	
13.	<p><b>Crank shaft Assembly</b></p> <ul style="list-style-type: none"> <li>■ Locate bearing in the housing in Crankcase LH and press crankshaft gently till the bearing is seated completely.</li> <li>■ Rotate Crankshaft such that the crank webs are at their lowest position &amp; the dot mark on the gear in crankshaft is facing towards the front.</li> </ul>	<p><b>NOTE:</b></p> <p>Smear oil on bearing outer race.</p> <p>Hold crankshaft vertically &amp; ensure bearing enters crankcase LH squarely.</p>	
14.	<p><b>Balancer shaft Assembly</b></p> <ul style="list-style-type: none"> <li>■ Position balancer shaft such that the dot mark on balancer shaft gear aligns with dot mark on crankshaft gear and gently press balancer shaft into the bearing in crankcase LH</li> </ul>	<p><b>NOTE:</b></p> <p>Ensure dot marks on crankshaft gear &amp; balancer shaft gear are matched correctly.</p>	
15.	<p><b>Crankcase Boxing</b></p> <ul style="list-style-type: none"> <li>■ Ensure Gasket sealant is applied evenly and uniformly on the mating surface of crankcase LH</li> <li>■ Ensure dowels are located in crankcase LH.</li> <li>■ Locate Crankcase RH over crankcase LH and gently tap it in while gently rotating the shafts</li> <li>■ Ensure Crankcase RH is fully seated over crankcase LH &amp; all shafts are rotating freely.</li> </ul>	<p><b>NOTE:</b></p> <p>Apply Loctite No 5699 on the mating surface of crankcase LH.</p>	





S. No.	Aggregate to Assemble / Instructions	Fastener, Size, Tool Usage, Precautions, Photos	
<b>16.</b>	<b>Crankcase Fasteners</b>		
	<b>Assemble</b>		
	<ul style="list-style-type: none"> <li>■ Hex Socket Head screw in Crankcase LH below Barrel seating area.</li> </ul>	<p><b>Hex Socket Hd Screw: M8 X 100</b>  <b>Allen key: M6</b>  <b>Torque: 2-2.4KgM (20-24Nm)</b></p>	
	<ul style="list-style-type: none"> <li>■ 3 hex bolts in magneto area in crankcase LH.</li> </ul>	<p><b>Hex Flange Bolt- M8 X 70</b>  <b>Socket spanner: 12mm</b>  <b>Torque: 2-2.4KgM (20-24Nm)</b></p>	
	<ul style="list-style-type: none"> <li>■ 1 Hex flange bolt in crankcase LH near starter motor housing</li> </ul>	<p><b>Hex Flange Bolt- M6 X 60</b>  <b>Socket spanner: 8mm</b>  <b>Torque: 0.8-1.2KgM (8-12Nm)</b></p>	
	<ul style="list-style-type: none"> <li>■ 4 Hex flange bolts in crankcase LH front.</li> </ul>	<p><b>Hex Flange Bolt- M6 X 60</b>  <b>Socket spanner: 8mm</b>  <b>Torque: 0.8-1.2KgM (8-12Nm)</b></p>	
	<ul style="list-style-type: none"> <li>■ 6 Hex bolts (Longest) in crankcase LH rear.</li> </ul>	<p><b>Hex Flange Bolt- M6 X 85</b>  <b>Socket spanner: 8mm</b>  <b>Torque: 0.8-1.2KgM (8-12Nm)</b></p>	





S. No.	Aggregate to Assemble / Instructions	Fastener, Size, Tool Usage, Precautions, Photos	
16.	<p><b>Crankcase Fasteners</b></p> <p><b>Assemble</b></p> <ul style="list-style-type: none"> <li>■ 3 Hex bolts from crankcase LH bottom</li> </ul>	<p><b>Hex Flange Bolt- M6 X 60</b>  <b>Socket spanner: 8mm</b>  <b>Torque: 0.8-1.2KgM (8-12Nm)</b></p>	<p><b>NOTE:</b></p> <p>Tighten all fasteners evenly &amp; diagonally, for proper sealing of the crankcase joints</p> 
17.	<p><b>Piston Rings Assembly</b></p> <ul style="list-style-type: none"> <li>■ Assemble Oil control ring with stiffener ring in the 3<sup>rd</sup> groove.</li>   <li>■ Assemble 2<sup>nd</sup> compression ring in the middle groove.</li>   <li>■ Assemble 1<sup>st</sup> compression ring in the top most groove.</li> </ul>	<p><b>NOTE:</b></p> <p>Ensure stiffener ring is correctly located between the 2 oil Control rings.</p>	<p><b>NOTE:</b></p> <p>Ensure the words "TOP" 2 in 2<sup>nd</sup> compression ring &amp; "TOP 1" in 1<sup>st</sup> compression ring are facing towards the top of the piston.</p> <p>Lubricate rings well &amp; position ring end gaps at 120° to each other, for easy assembly of cylinder barrel.</p>   



S. No.	Aggregate to Assemble / Instructions	Fastener, Size, Tool Usage, Precautions, Photos	
18.	<p><b>Oil Jet</b></p> <ul style="list-style-type: none"> <li>Locate oil jet in Crankcase RH, barrel seating area with its slotted end facing up and press into crankcase gently.</li> </ul>	<p><b>NOTE:</b></p> <p>Ensure 'O' ring does not get damaged during assembly.</p> <p>Ensure slotted end of jet is facing outside.</p>	
19.	<p><b>Cylinder Barrel Gasket</b></p> <ul style="list-style-type: none"> <li>Locate the two dowels on Crankcase LH.</li> <li>Locate gasket on Crankcase ensuring the recess for the oil jet is correctly positioned.</li> </ul>	<p><b>NOTE:</b></p> <p>Apply grease on gasket seating surface.</p> <p><b>Caution:</b></p> <p>Gasket is unidirectional hence ensure it is fitted correctly.</p>	
20.	<p><b>Piston Assembly on Connecting Rod</b></p> <ul style="list-style-type: none"> <li>Assemble circlip on piston, on one side &amp; insert piston pin from the other side. Ensure the pin is pressed just sufficiently into the piston and not protruding into piston</li> <li>Support connecting rod using special tool to hold it vertically for assembling piston.</li> </ul>	<p><b>CAUTION:</b></p> <p>Ensure circlip locks in place and does not fall into crankcase.</p> <p>Remove cloth after assembling circlip.</p> <p><b>Special Tool: ST-27529-2, Piston Support.</b></p>	  

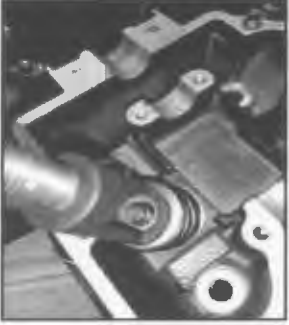

S. No.	Aggregate to Assemble / Instructions	Fastener, Size, Tool Usage, Precautions, Photos
20.	<p><b>Piston Assembly on Connecting Rod</b></p> <ul style="list-style-type: none"> <li>■ Position piston on connecting rod, ensuring the piston pin holes in both piston &amp; connecting rod are aligned.</li> <li>■ Lubricate piston pin &amp; gently insert into piston till it rests on the circlip</li> <li>■ Cover crankcase spigot suitably &amp; assemble the other circlip on the piston.</li> </ul>	<p><b>NOTE:</b></p> <p>Ensure marking, "EX" on the piston is facing towards crankcase front.</p> <p><b>CAUTION:</b></p> <p>Ensure circlip locks in place and does not fall into crankcase.</p> <p>Remove cloth after assembling circlip.</p> 
21.	<p><b>Cylinder Barrel on piston</b></p> <ul style="list-style-type: none"> <li>■ Lubricate piston rings, piston &amp; cylinder barrel, with oil, for easy entry of piston into cylinder barrel.</li> <li>■ Ensure Piston is supported vertically.</li> <li>■ Gently lower barrel over piston while simultaneously compressing rings for easy entry.</li> <li>■ Remove piston supporting tool &amp; lower barrel fully into Crankcase.</li> </ul>	  



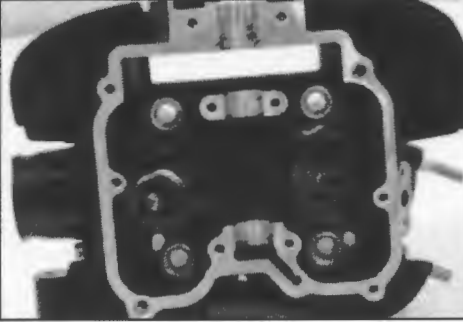
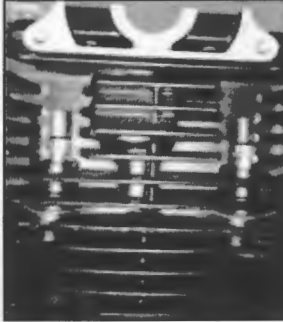

S. No.	Aggregate to Assemble / Instructions	Fastener, Size, Tool Usage, Precautions, Photos
21.	<p><b>Cylinder Barrel on piston</b></p> <ul style="list-style-type: none"> <li>■ Rotate Crank Shaft Assembly to bring piston to TDC.</li>   <li>■ Tighten barrel to Crankcase using 2 Flanged Hex nuts on the LH side.</li> </ul>	<div data-bbox="597 401 917 546" style="border: 1px solid black; padding: 5px;"> <p><b>Hex Flange Nut: M6 X 1 D E Spanner: 8 mm Torque: 0.8-1.2KgM (8-12Nm)</b></p> </div> <div data-bbox="1122 390 1409 711" style="text-align: right;">  </div> <div data-bbox="938 768 1401 1092" style="text-align: right;">  </div>
22.	<p><b>Cylinder head Gasket</b></p> <ul style="list-style-type: none"> <li>■ Locate 2 dowels on cylinder barrel top LH side. Locate cylinder head gasket over the cylinder barrel.</li> </ul>	<div data-bbox="597 1146 917 1312" style="border: 1px solid black; padding: 5px;"> <p><b>NOTE:</b> Apply grease on cylinder head gasket for proper seating.</p> </div> <div data-bbox="1122 1142 1409 1463" style="text-align: right;">  </div>
23.	<p><b>Cam Chain Pads</b></p> <ul style="list-style-type: none"> <li>■ Insert chain tensioner pad through cylinder barrel.</li> <li>■ Apply grease on the thrust washer to hold it in place over the threaded location in crankcase LH.</li> <li>■ Position chain pad over thrust washer &amp; tighten with hex socket Head stepped bolt.</li> </ul>	<div data-bbox="597 1514 917 1696" style="border: 1px solid black; padding: 5px;"> <p><b>Stepped Hex socket Bolt: M6X14 Allen Key: M5 Torque: 1.0 - 1.2KgM (10-12Nm)</b></p> </div> <div data-bbox="1122 1505 1409 1827" style="text-align: right;">  </div>



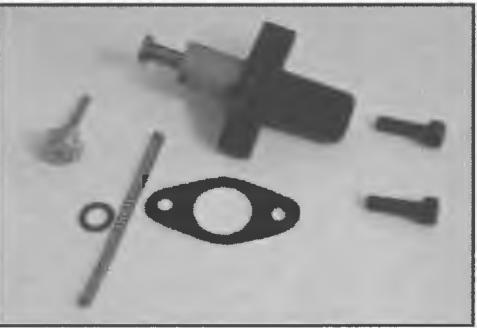

S. No.	Aggregate to Assemble / Instructions	Fastener, Size, Tool Usage, Precautions, Photos
23.	<p><b>Cam Chain Pads</b></p> <ul style="list-style-type: none"> <li>■ Insert the cam chain through the cylinder barrel &amp; locate it on the crank shaft gear.</li>   <li>■ Ensure chain is properly supported at the top to prevent it from dropping into the crankcase.</li>   <li>■ Insert fixed cam chain pad through cylinder barrel &amp; locate it in the crankcase LH</li> </ul>	<p><b>NOTE:</b> Apply grease on the gear &amp; chain to hold the chain in place.</p>   <p><b>NOTE:</b> Ensure fixed chain pad is locked in position in cylinder barrel.as well as crankcase LH.</p> 
24.	<p><b>Valves in Cylinder Head</b></p> <ul style="list-style-type: none"> <li>■ Insert inlet valve into valve guide from inside cylinder head.</li> <li>■ Assemble spring seat, inner spring, outer spring &amp;retainer, from the top of cylinder head.</li> <li>■ Locate valve spring compressing tool over the retainer &amp; compress spring till the valve stem comes out through the retainer.</li> </ul>	<p><b>NOTE:</b> Ensure stem seals are fitted on the valve guide. Ensure denser coils of the spring are seated on the spring seat in cylinder head.</p> 





S. No.	Aggregate to Assemble / Instructions	Fastener, Size, Tool Usage, Precautions, Photos	
24.	<p><b>Valves in Cylinder head.</b></p> <ul style="list-style-type: none"> <li>■ Insert split collars on retainer. Ensure they are seated correctly against valve stem and retainer &amp; release puller slowly.</li> <li>■ Repeat above procedure to assemble exhaust valve.</li> </ul>	<p><b>Special tool: ST-27528-2, Valve spring compressor.</b></p> <p><b>CAUTION:</b> Ensuresplit collars are correctly locked between retainer &amp; valve stem.</p>	 
25.	<p><b>Cylinder Head Assembly</b></p> <ul style="list-style-type: none"> <li>■ Position cylinder head assembly over cylinder barrel.</li> <li>■ Holding the cam chain from the top, route it through the slot in cylinder head bottom and locate the cylinder head on the barrel correctly.</li> </ul>	<p><b>NOTE:</b> Apply grease on crankshaft sprocket &amp; chain to hold it in place. Secure chain from top to prevent it from dropping into crankcase.</p>	 



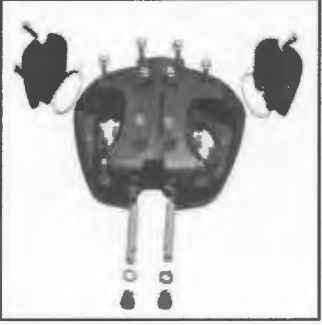

S. No.	Aggregate to Assemble / Instructions	Fastener, Size, Tool Usage, Precautions, Photos	
25.	<p><b>Cylinder Head Assembly</b></p> <ul style="list-style-type: none"> <li>■ Locate 4 special Hex bolts with washer &amp; tighten diagonally.</li>   <li>■ Locate 2 Hex flange bolts on cylinder head LH side and tighten.</li> </ul>	<p><b>Special Hex Bolts: M10X170</b>  <b>Hex Socket: 12mm</b>  <b>Torque: 4-4.5KgM (40-45Nm)</b></p> <p><b>Hex flange bolts: M6X30</b>  <b>D E Spanner: 8mm</b>  <b>Torque: 0.8-1.2KgM (8-12Nm)</b></p>	 
26.	<p><b>Cam Chain &amp; Sprocket Assembly</b></p> <ul style="list-style-type: none"> <li>■ Locate cam shaft along with sprocket on cylinder head.</li>   <li>■ Ensure sprocket is free on cam shaft &amp; locate chain on sprocket with marking "T" on sprocket facing up.</li> <li>■ Rotate cam shaft, without disturbing the sprocket till the dowel in the shaft aligns with the hole in the sprocket.</li> <li>■ Ensure chain has no slack &amp; insert cam shaft into sprocket such that the dowel locates into the sprocket.</li> </ul>	<p><b>NOTE:</b></p> <p>Ensure Key way in crankshaft is facing up so that piston is at TDC on compression stroke.</p> <p><b>CAUTION:</b></p> <ul style="list-style-type: none"> <li>- Ensure reference lines on cam sprocket &amp; cam shaft are parallel &amp; aligned.</li> <li>- Crankshaft keyway is at TDC position.</li> </ul>	 





S. No.	Aggregate to Assemble / Instructions	Fastener, Size, Tool Usage, Precautions, Photos	
26.	<p><b>Cam Chain &amp; Sprocket Assembly</b></p> <ul style="list-style-type: none"> <li>■ Fix 1 hex bolt with lock plate on sprocket &amp; tighten just sufficiently.</li> <li>■ Rotate camshaft slowly &amp; tighten 2nd Hex bolt, through the lock plate.</li>   <li>■ Tighten both bolts &amp; bend lock plate over the bolts.</li> </ul>	<p><b>Hex Bolt: M6X12</b>  <b>Hex Socket: 8 mm</b>  <b>Torque: 1-1.2KgM (10-12Nm)</b></p>	
27.	<p><b>Cam Shaft Lock "C" washer.</b></p> <ul style="list-style-type: none"> <li>■ Align slot in cam shaft with the groove in cylinder head.</li> <li>■ Insert "C" washer into cylinder head to lock axial movement of the cam shaft</li> </ul>	<p><b>NOTE:</b>  Ensure "C" washer is located correctly into the slot in cylinder head failing which the cylinder head cover cannot seat properly</p>	
28.	<p><b>Auto Chain Tensioner Assembly</b></p> <ul style="list-style-type: none"> <li>■ Ensure center bolt with spring is removed from assembly.</li> <li>■ Release lock on chain tensioner body &amp; depress pad completely.</li> </ul>	<p><b>NOTE:</b>  Ensure gasket is assembled on the Auto chain tensioner Assembly.</p>	



S. No.	Aggregate to Assemble / Instructions	Fastener, Size, Tool Usage, Precautions, Photos
28.	<p><b>Auto Chain Tensioner Assembly</b></p> <ul style="list-style-type: none"> <li>■ Locate chain tensioner assembly in cylinder barrel &amp; tighten with 2 Hex socket head screws.</li> <li>■ Locate 'O' ring in the chain tensioner body.</li> <li>■ Insert spring into chain tensioner and tighten with special Hex bolt.</li> </ul>	<p><b>NOTE:</b> Ensure lock in chain tensioner assembly is facing downwards</p> <p><b>Hex Socket Hd Screw: M6X25</b> <b>Allen Key: 5mm</b> <b>Torque: 1-1.2KgM (10-12Nm)</b></p> <p><b>Special Hex bolt: M8</b> <b>Hex socket: 10mm</b> <b>Torque: 0.8-1.0KgM (8-10Nm)</b></p>  
29.	<p><b>Spark Plug</b></p> <ul style="list-style-type: none"> <li>■ Assemble spark plug on cylinder head.</li> </ul>	<p><b>NOTE:</b> Ensurespark plug gap is set 0.7 - 0.8 mm</p> <p><b>Socket Spanner: 16mm</b> <b>Torque: 1-1.5KgM (10-15Nm)</b></p> 
30.	<p><b>Inlet Manifold</b></p> <ul style="list-style-type: none"> <li>■ Assemble Inlet manifold with the PAV inlet nipple facing downwards.</li> <li>■ Tighten with 2 Hex socket head screws with copper washers.</li> </ul>	<p><b>NOTE:</b> Ensure 'O' ring is located in the Inlet manifold.</p> <p><b>Hex Socket Hd screw: M6X25</b> <b>Allen key: 5mm</b> <b>Torque: 0.8-1.2KgM (8-12Nm)</b></p> 

S. No.	Aggregate to Assemble / Instructions	Fastener, Size, Tool Usage, Precautions, Photos
31.	<p><b>Inlet Rocker arm &amp; shaft in Cylinder head cover</b></p> <ul style="list-style-type: none"> <li>■ Position inlet rocker arm inside cover such that the tappet adjustment screw on the rocker arm is facing outside &amp; roller is facing inside.</li> <li>■ Assemble rocker shaft in the cylinder head cover such that the slot and the internal threads in the shaft are facing outside.</li> <li>■ Ensure the slot in the rocker shaft is perpendicular to the top mounting hole in the cylinder head cover such that the cover mounting bolt can pass through the slot in the rocker shaft.</li> </ul>	  
32.	<p><b>Exhaust Rocker arm &amp; shaft in Cylinder head cover</b></p> <ul style="list-style-type: none"> <li>■ Position exhaust rocker arm inside cover such that the tappet adjustment screw on the rocker arm is facing outside &amp; roller is facing inside.</li> </ul>	





S. No.	Aggregate to Assemble / Instructions	Fastener, Size, Tool Usage, Precautions, Photos
32	<p><b>Exhaust Rocker arm &amp; shaft in Cylinder head cover</b></p> <ul style="list-style-type: none"> <li>■ Assemble rocker shaft in the cylinder head cover such that the slot and the internal threads in the shaft are facing outside.</li> <li>■ Ensure the slot in the rocker shaft is perpendicular to the top mounting hole in the cylinder head cover such that the cover mounting bolt can pass through the slot in the rocker shaft.</li> <li>■ Assemble 2 Hex Socket pre coated plugs with copper washers in the cylinder head cover.</li> </ul>	<div style="display: flex; flex-direction: column; align-items: flex-end;">   <div style="border: 1px solid black; padding: 5px; margin: 5px 0;"> <p><b>Hex Socket Hd plug: M14X12</b>  <b>Allen key: 8mm</b>  <b>Torque: 2.5-3.0KgM (25-30Nm)</b></p> </div>  </div>
33.	<p><b>Cylinder Head Cover</b></p> <ul style="list-style-type: none"> <li>■ Apply Loctite 5900 gasket sealant on cylinder head mating surface.</li> <li>■ Locate cylinder head cover on the cylinder head and ensure proper seating.</li> <li>■ Assemble 2 long Hex flange bolts with aluminum washers in the top RH side.</li> </ul>	<div style="display: flex; flex-direction: column; align-items: flex-end;"> <div style="border: 1px solid black; padding: 5px; margin-bottom: 10px;"> <p><b>NOTE:</b></p> <ul style="list-style-type: none"> <li>- Ensure the 2 dowels are located in cylinder head.</li> <li>- Aluminum washers are provided to prevent oil leak through the bolts.</li> </ul> </div>  </div>

S. No.	Aggregate to Assemble / Instructions	Fastener, Size, Tool Usage, Precautions, Photos
33.	<p><b>Cylinder Head Cover</b></p> <ul style="list-style-type: none"> <li>■ Assemble 3 long Hex flange bolts in the top RH side. Assemble 2 long Hex flange bolts with aluminium washers in the centre RH side.</li> <li>■ Assemble 3 long Hex flange bolts in the top LH side.</li> <li>■ Assemble medium length Hex flange bolt in the RH side rear.</li> <li>■ Assemble small Hex flange bolt in RH side front.</li> <li>■ Assemble 2 fully threaded Hex flange bolts inside the inlet &amp; Exhaust tappet housing areas.</li> <li>■ Tighten all the bolts just sufficiently. Do not torque tighten fully</li> </ul>	<div style="border: 1px solid black; padding: 2px; margin-bottom: 5px;">Hex flange bolts: M6X55 Socket Spanner: 8mm</div> <div style="border: 1px solid black; padding: 2px; margin-bottom: 5px;">Hex flange bolts: M6X60 Socket Spanner: 8mm</div> <div style="border: 1px solid black; padding: 2px; margin-bottom: 5px;"><b>NOTE:</b> Aluminium washers are provided to prevent oil leak through the bolts.</div> <div style="border: 1px solid black; padding: 2px; margin-bottom: 5px;">Hex flange bolts: M6X60 Socket Spanner: 8mm</div> <div style="border: 1px solid black; padding: 2px; margin-bottom: 5px;">Hex flange bolts: M6X45 Socket Spanner: 8mm</div> <div style="border: 1px solid black; padding: 2px; margin-bottom: 5px;">Hex flange bolts: M6X40 Socket Spanner: 8mm</div> <div style="border: 1px solid black; padding: 2px; margin-bottom: 5px;">Hex flange bolts: M6X21 Socket Spanner: 8mm</div> <div style="display: flex; flex-direction: column; align-items: center;">     </div>

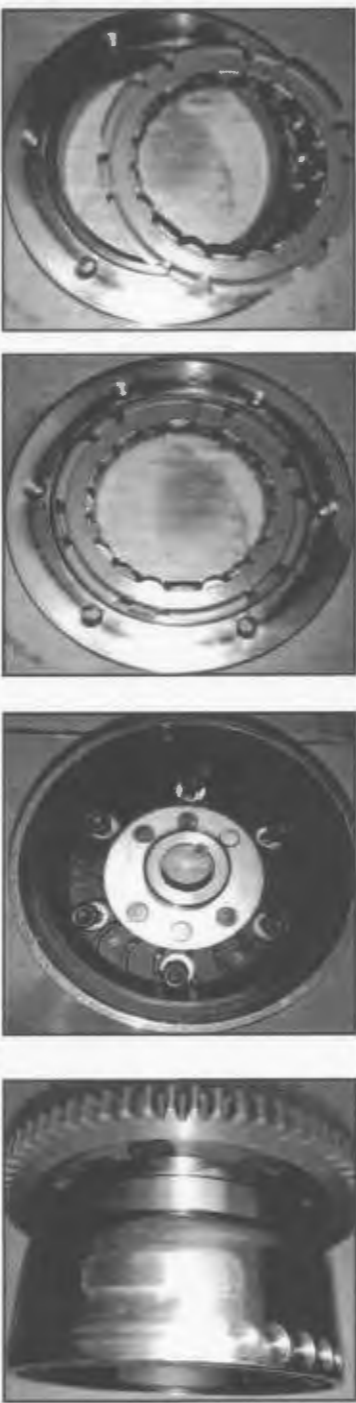

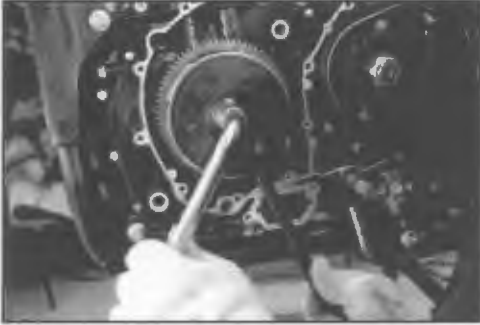

S. No.	Aggregate to Assemble / Instructions	Fastener, Size, Tool Usage, Precautions, Photos	
34.	<p><b>Camshaft Cover small.</b></p> <ul style="list-style-type: none"> <li>■ Locate 'O' ring in cam shaft cover small.</li> <li>■ Locate cam shaft cover in cylinder head &amp; align fixing hole.</li> <li>■ Assemble Hex flange bolt (fully threaded).</li> <li>■ Tighten Hex flange bolt on cam shaft cover small AND the 12 bolts on cylinder head cover, diagonally using 8mm socket spanner to respective torque values.</li> </ul>	<p><b>NOTE:</b></p> <p>Apply Loctite 5900 gasket sealant on seating face before locating on cylinder head cover</p>	
		<p><b>Hex flange bolt: M6X16</b> <b>Socket spanner: 8mm</b></p>	
		<p><b>Hex flange bolts: M6X60, M6X55, M6X45 &amp; M6X40</b> <b>Torque: 1.0-1.4KgM (10-14Nm)</b> <b>Hex flange bolts: M6X21</b> <b>Torque: 0.8-1.2KgM (8-12Nm)</b></p>	
35.	<p><b>Cam Shaft Cover Big</b></p> <ul style="list-style-type: none"> <li>■ Assemble cover and tighten with 2 Hex flange bolts (fully threaded)</li> </ul>	<p><b>Hex flange bolt: M6X16</b> <b>Socket spanner: 8mm</b> <b>Torque: 0.8-1.2KgM (8-12Nm)</b></p>	
36.	<p><b>Tappets Adjustment</b></p> <ul style="list-style-type: none"> <li>■ If Magneto rotor NOT fitted on crankshaft: <ul style="list-style-type: none"> <li>- Ensure key way on crankshaft is facing up &amp; piston is at TDC</li> </ul> </li> <li>■ If Magneto rotor is fitted on crankshaft <ul style="list-style-type: none"> <li>- Rotate magneto rotor "CLOCKWISE ONLY" such that the reference mark on the rotor aligns with the inspection hole on cover LH/ Reference mark on Crankcase LH.</li> </ul> </li> </ul>	<p><b>NOTE:</b></p> <p>Tappets MUST be adjusted ONLY WHEN:</p> <ul style="list-style-type: none"> <li>- Engine is cold</li> <li>- Piston is at TDC on Compression stroke.</li> </ul>	

S. No.	Aggregate to Assemble / Instructions	Fastener, Size, Tool Usage, Precautions, Photos	
36.	<p><b>Tappets Adjustment</b></p> <ul style="list-style-type: none"> <li>■ Locate special tool &amp; loosen adjuster lock nut by turning the long lever anticlockwise.</li> <li>■ Using a pointed feeler strip, set the specified gap by rotating the knurled head of the special tool: <ul style="list-style-type: none"> <li>- Clockwise to reduce gap.</li> <li>- Anticlockwise to increase gap.</li> </ul> </li> <li>■ Hold the knurled head firmly so that the tappet adjustment does not get disturbed &amp; lock the tappet locknut firmly by turning long lever clockwise.</li> </ul>	<p><b>Special Tool: ST-27527-2, Tappet adjusting tool &amp; pointed, long feeler strip.</b></p>	
		<p><b>Tappet Setting:</b>  <b>Inlet: 0.08 - 0.10mm</b>  <b>Exhaust: 0.23 - 0.25mm</b></p>	
		<p><b>CAUTION:</b></p> <p>DO NOT adjust the tappets too tight as it will result in heavy load coming on the rocker shafts and damaging the bore in the cylinder head cover.</p>	
37.	<p><b>Tappet Adjuster Cover Inlet</b></p> <ul style="list-style-type: none"> <li>■ Locate O Ring in cover inlet &amp; position cover over cylinder head cover. Tighten with 2 Hex bolts.</li> </ul>	<p><b>Hex flange bolts: M6X21</b>  <b>Socket Spanner: 8mm</b>  <b>Torque: 0.8-1.2KgM (8-12</b></p>	
38.	<p><b>Tappet Adjuster Cover Exhaust</b></p> <ul style="list-style-type: none"> <li>■ Locate O Ring in cover exhaust &amp; position cover over cylinder head cover.</li> <li>■ Tighten with 2 hex bolts.</li> </ul>	<p><b>Hex flange bolts: M6X21</b>  <b>Socket Spanner: 8mm</b>  <b>Torque: 0.8-1.2KgM (8-12 Nm)</b></p>	





S. No.	Aggregate to Assemble / Instructions	Fastener, Size, Tool Usage, Precautions, Photos		
39.	<p><b>Starter Clutch Assembly</b></p> <ul style="list-style-type: none"> <li>■ Assemble starter clutch such that the starter shoulder is seated in the groove in the ring bearing.</li>   <li>■ Locate ring gear with starter clutch on magneto such that the recess in the ring bearing is seated on the magneto.</li>   <li>■ Tighten ring gear to magneto with 6 Hex Socket Head screws.</li>   <li>■ Assemble Big ring gear into starter clutch by rotating anti clock wise &amp; pressing gently, to allow for starter clutch to expand and allow flush seating of big ring gear</li> </ul>	<p><b>CAUTION:</b></p> <p>Do not force or hammer starter bearing into ring gear as it will damage the starter bearing.</p> <p>Apply oil &amp; gently press the bearing into the ring gear.</p>	<p><b>Hex SocHd screw: M6X20</b>  <b>Allen key: M5</b>  <b>Torque: 1.0-1.2KgM (10-12 Nm)</b></p>	





S. No.	Aggregate to Assemble / Instructions	Fastener, Size, Tool Usage, Precautions, Photos
40.	<p><b>Magneto rotor</b></p> <ul style="list-style-type: none"> <li>■ Ensure the crankshaft is in TDC position and locate woodruff key on shaft.</li>   <li>■ Locate Magneto rotor with starter clutch on the shaft ensuring the woodruff key slot is correctly aligned with the woodruff key and gently tap magneto rotor till it is seated fully in the shaft</li> <li>■ Locate rotor holding special tool in the magneto rotor</li> <li>■ Ensure the 3 lugs of the special tool are firmly seated on 3 hex socket head screws inside magneto rotor to prevent it from rotating while tightening.</li> <li>■ Assemble Hex Flange nut and tighten.</li> <li>■ Remove the magneto rotor holding special tool</li> </ul>	<div style="display: flex; flex-direction: column; align-items: center;">   <div style="border: 1px solid black; padding: 5px; margin: 10px 0;"> <p><b>Hex nut: M12X1.25X11</b>  <b>Socket spanner: 19mm</b>  <b>Torque: 7-8KgM (70-80 Nm)</b></p> </div> <div style="border: 1px solid black; padding: 5px; margin: 10px 0;"> <p><b>Special Tool: ST-27534-2, Magneto rotor &amp; FD sprocket locking tool</b></p> </div>  </div>
41.	<p><b>Idler gears on Crankcase LH</b></p> <ul style="list-style-type: none"> <li>■ Insert the 2 idler gear spindles into crankcase LH</li> <li>■ Assemble double gear with the smaller gear facing outwards.</li> </ul>	









S. No.	Aggregate to Assemble / Instructions	Fastener, Size, Tool Usage, Precautions, Photos	
42.	<p><b>Starter Motor</b></p> <ul style="list-style-type: none"> <li>■ Tighten starter motor to crankcase with 2 hex flange bolts.</li> </ul>	<p><b>NOTE:</b> Ensure earth terminal is located on the outside hex flange bolt of the starter motor before tightening both bolts.</p> <p>Hex flange bolt: M8 Socket Spanner: 10mm Torque: 0.8-1.2KgM (10-12Nm)</p>	
43.	<p><b>Drive Shaft Spacer</b></p> <ul style="list-style-type: none"> <li>■ Fix 'O' ring inside the spacer.</li> <li>■ Assemble spacer on drive shaft.</li> </ul>	<p><b>NOTE:</b> The spacer has to be assembled on the shaft such that the 4 slots are facing inside.</p>	 
44.	<p><b>FD Sprocket</b></p> <ul style="list-style-type: none"> <li>■ Assemble FD sprocket on drive shaft.</li> </ul>		









S. No.	Aggregate to Assemble / Instructions	Fastener, Size, Tool Usage, Precautions, Photos	
46.	<p><b>Cover LH</b></p> <ul style="list-style-type: none"> <li>■ Locate gasket on crankcase LH.</li> <li>■ Locate cover LH on the dowel &amp; tap it in gently.</li> <li>■ Assemble 3 long Hex flange bolts on cover rear side.</li> <li>■ Assemble 8 short Hex Flange bolts on the front top, Centre &amp; bottom sides..</li> </ul>	<p><b>NOTE:</b> Apply grease on gasket to hold it in position.</p> <p><b>NOTE:</b> Take care to ensure stator assembly is correctly located into magneto rotor and the wire grommet is seated properly on cover LH</p> <p><b>Hex flange bolt: M6X35 &amp; M6X55</b> <b>Socket spanner: 8mm</b> <b>Torque: 0.8-1.2KgM (8-12Nm)</b></p>	  
47.	<p><b>Timing mark Inspection plug</b></p> <ul style="list-style-type: none"> <li>■ Assemble plug with copper washer on cover LH and tighten.</li> </ul>	<p><b>Hex Plug: M14X12</b> <b>Socket spanner: 17mm</b> <b>Torque: 2.0-2.5KgM (20-25Nm)</b></p>	

S. No.	Aggregate to Assemble / Instructions	Fastener, Size, Tool Usage, Precautions, Photos	
48.	<p><b>RE Logo cover on cover LH</b></p> <ul style="list-style-type: none"> <li>■ Ensure "O" ring is correctly located in the groove in logo cover LH.</li> <li>■ Position logo cover on cover LH and tighten with 2 hex socket head screws.</li> </ul>	<p><b>Hex Soc Hd. Screw: M6X14</b>  <b>Allen key: 5mm</b>  <b>Torque: 0.8-1.2KgM (8-12Nm)</b></p>	
49.	<p><b>FD Sprocket Cover</b></p> <ul style="list-style-type: none"> <li>■ Locate FD sprocket cover over crankcase LH &amp; tighten with 2 Hex flange bolts.</li> </ul>	<p><b>Hex flange bolts: M6X35</b>  <b>Socket Spanner: 8mm</b>  <b>Torque: 0.8-1.2KgM (8-12Nm)</b></p>	
50.	<p><b>Gear Star Index</b></p> <ul style="list-style-type: none"> <li>■ Locate star index on the cam comp. gear shift correctly such that the 2 pegs are fully locked in start index.</li> <li>■ Tighten star index to cam comp. gear shift with stepped bolt hex socket head screw.</li> </ul>	<p><b>NOTE:</b>  Ensure the offset holes in the star index are seated correctly on the 2 pegs on cam comp. gear shift</p> <p><b>Stepped bolt hex soc Hd screw</b>  <b>Allen key: M4</b>  <b>Torque: 1-1.2KgM (10-12Nm)</b></p>	
51.	<p><b>Gear Star Index Stopper</b></p> <ul style="list-style-type: none"> <li>■ Locate blackened thrust washer behind star index stopper.</li> <li>■ Locate spring on star index stopper such that the curved end of spring is seated in the groove provided.</li> <li>■ Tighten with Hex bolt.</li> </ul>	<p><b>Hex bolt: M8</b>  <b>Socket spanner: M10</b>  <b>Torque: 1-1.2 KgM (10-12Nm)</b></p>	



S. No.	Aggregate to Assemble / Instructions	Fastener, Size, Tool Usage, Precautions, Photos	
52.	<p><b>Gear Shift Shaft</b></p> <ul style="list-style-type: none"> <li>■ Insert gear shift shaft assembly, from Crankcase RH.</li>   <li>■ Assemble black thrust washer on LH side of shaft.</li> <li>■ Assemble circlip on LH side of gear shift shaft.</li> </ul>	<p><b>NOTE:</b></p> <p>Ensure spring legs are correctly positioned on the stopper in crankcase RH.</p> <p>Ensure circlip is properly seated.</p>	
53.	<p><b>Gear Shift Shaft</b></p> <ul style="list-style-type: none"> <li>· Locate gear selector assembly on shaft such that the lugs are correctly located in the star index and the peg in the gear shift shaft is located into selector assembly.</li> </ul>	<p><b>NOTE:</b></p> <p>Ensure lugs of the gear selector are located on the star index.</p> <p>The peg in the shift shaft is located in the selector.</p>	
54.	<p><b>Gear Selector</b></p> <ul style="list-style-type: none"> <li>· Assemble spring &amp; washer.</li> </ul>		



S. No.	Aggregate to Assemble / Instructions	Fastener, Size, Tool Usage, Precautions, Photos	
54.	<p><b>Gear Selector</b></p> <ul style="list-style-type: none"> <li>■ Compress spring &amp; assemble circlip on gear shift shaft on RH side.</li> </ul>	<p>External Circlip Plier</p>	
55.	<p><b>Drive shaft Spacer on RH side</b></p> <ul style="list-style-type: none"> <li>■ Assemble blackened washer, spacer &amp; blackened washer.</li> <li>■ Assemble circlip on gear drive shaft.</li> </ul>	<p>External Circlip Plier</p>	 
56.	<p><b>Clutch Plate Assembly</b></p> <ul style="list-style-type: none"> <li>■ Assemble beveled steel washer with the bevel facing upwards, in the groove in clutch hub.</li> </ul>		

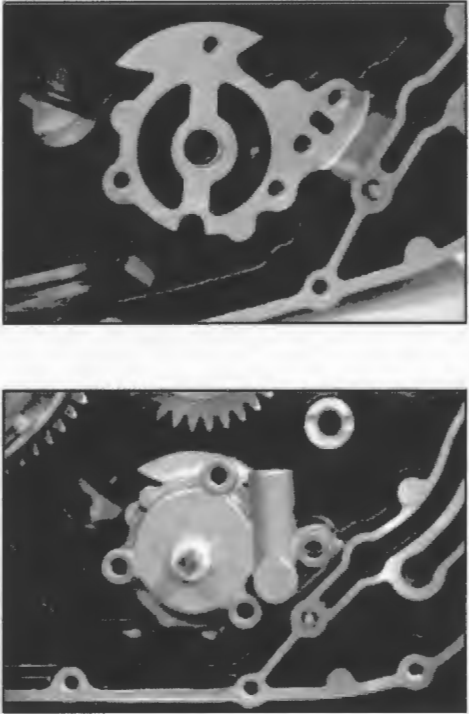

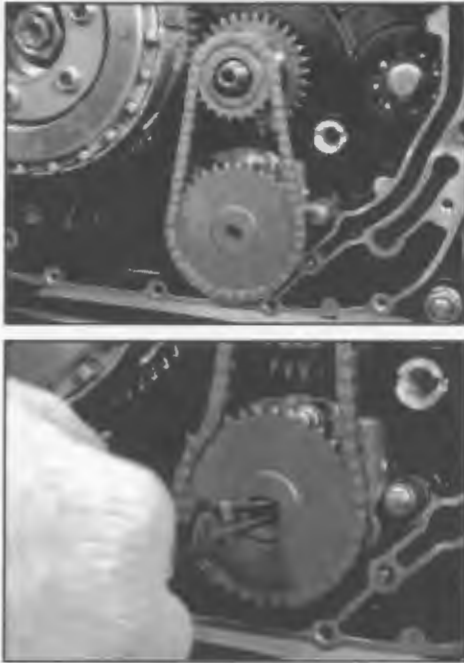
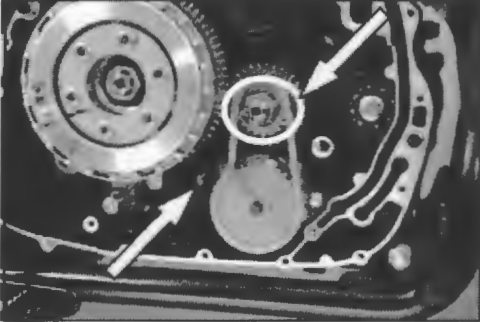

S. No.	Aggregate to Assemble / Instructions	Fastener, Size, Tool Usage, Precautions, Photos
56.	<p><b>Clutch Plate Assembly</b></p> <ul style="list-style-type: none"> <li>■ Assemble plain steel washer over beveled steel washer.</li> <li>■ Assemble 1<sup>st</sup> steel plate.- Assemble 1<sup>st</sup> friction plate with its lugs in line with the lugs on the clutch hub, to locate in the clutch housing.</li> <li>■ Assemble the balance steel plates &amp; friction plates on the clutch hub ensuring the lugs of the friction plate are in a straight line and between the lugs of the clutch hub.</li> <li>■ Assemble clutch back plate assembly over the clutch plates, with its lugs passing through the holes in the clutch hub.</li> <li>■ Carefully turn the assembly over to install the springs &amp; pressure plate.</li> <li>■ Compress springs &amp; pressure plate by fixing 2 long Hex bolts &amp; special tool to the clutch back plate assembly.</li> <li>■ Locate 4 Hex flange bolts and tighten evenly.</li> <li>■ Remove the 2 long Hex bolts &amp; special tool &amp; fix the balance 2 Hex flange bolts.</li> </ul>	<div style="display: flex; flex-direction: column; align-items: center;">     </div> <div style="margin-top: 20px; border: 1px solid black; padding: 5px; width: fit-content;"> <p><b>Special Tool: ST-27531-2, Clutch Locking Plate</b></p> </div> <div style="margin-top: 20px; border: 1px solid black; padding: 5px; width: fit-content;"> <p><b>Hex bolt: M8 Socket spanner: M10 Torque: 1-1.2 KgM (10-12Nm)</b></p> </div>

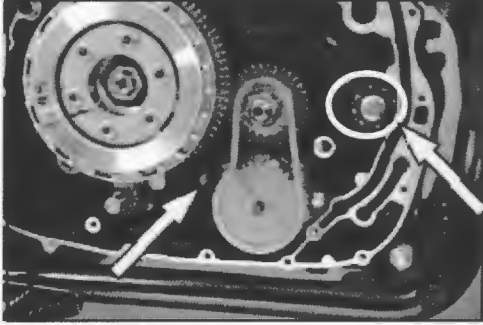



S. No.	Aggregate to Assemble / Instructions	Fastener, Size, Tool Usage, Precautions, Photos
57.	<p><b>Collared Bush on Counter shaft</b></p> <ul style="list-style-type: none"> <li>■ Assemble collared bush on counter shaft with its collar facing the bearing on crankcase RH.</li> </ul>	
58.	<p><b>Gear Primary Drive on Crank shaft</b></p> <ul style="list-style-type: none"> <li>■ Locate gear on the crankshaft splines.· Locate thrust washer.</li> </ul>	<div style="border: 1px solid black; padding: 5px; width: fit-content;"> <p><b>NOTE:</b></p> <p>The gear primary drive is a matched set with the clutch housing gear.</p> <p>Do not interchange the gear with any other clutch assy OR vice versa, as it will result in gears mismatch noise</p> </div> 
59.	<p><b>Clutch Assembly on Counter shaft</b></p> <ul style="list-style-type: none"> <li>■ Assemble clutch housing on bush.</li> <li>■ Assemble big metal washer on main shaft.</li> </ul>	

S. No.	Aggregate to Assemble / Instructions	Fastener, Size, Tool Usage, Precautions, Photos
59.	<p><b>Clutch Assembly on Counter shaft</b></p> <ul style="list-style-type: none"> <li>■ Locate clutch assembly into clutch housing such that the offset friction plate lug is seated on the recess in the clutch housing.</li> <li>■ Assemble splined washer on main shaft.</li> <li>■ Locate Hex nut M20 on counter shaft. Do not tighten fully.</li> </ul>	
60.	<p><b>Oil pump assembly</b></p> <ul style="list-style-type: none"> <li>■ Position pump gasket correctly on crankcase RH with a little grease to hold it in place.</li> <li>■ Ensure the holes in the gasket are aligned correctly to the holes in crankcase RH.</li> <li>■ Locate Pump correctly over the gasket, without disturbing its seating and ensuring the 4 mounting holes are aligned to the threaded portion in crankcase RH.</li> <li>■ Tighten Pump to crankcase RH using 4 hex flange bolts.</li> </ul>	 <div data-bbox="578 1591 896 1738" style="border: 1px solid black; padding: 5px; width: fit-content;"> <p><b>Hex Flange Bolt - M6 X 30</b>  <b>Socket spanner: M8</b>  <b>Torque: 0.7- 0.9KgM (7-9 Nm)</b></p> </div>

S. No.	Aggregate to Assemble / Instructions	Fastener, Size, Tool Usage, Precautions, Photos
61.	<p><b>Oil pump sprocket &amp; chain assembly</b></p> <ul style="list-style-type: none"> <li>■ Locate small and big drive gears in the oil pump chain.</li> <li>■ Locate small gear on crankshaft and slot in big gear on the oil pump shaft, duly ensuring it is seated correctly.</li> <li>■ Assemble circlip over the big gear in the groove in the oil pump shaft &amp; ensure it is seated properly.</li> </ul>	
62.	<p><b>Crank shaft nut</b></p> <ul style="list-style-type: none"> <li>■ Assemble small thrust washer and special LH thread hex nut over small gear on crankshaft.</li> <li>■ Locate special tool between crankshaft gear &amp; clutch housing gear at the top to lock crankshaft.</li> <li>■ Rotate "ANTI CLOCK-WISE" to tighten nut.</li> </ul>	<div data-bbox="578 1163 894 1297" style="border: 1px solid black; padding: 5px;"> <p><b>CAUTION:</b> LH thread nut. Tighten by rotating Anti Clockwise.</p> </div> <div data-bbox="578 1318 894 1392" style="border: 1px solid black; padding: 5px;"> <p><b>Special Tool: ST-27533-2, Crank Gears locking Tool</b></p> </div> <div data-bbox="578 1413 894 1547" style="border: 1px solid black; padding: 5px;"> <p><b>Nut LH thread: M18 Socket spanner: 24mm Torque: 8.5- 9.0 KgM (85-90 Nm)</b></p> </div> 
63.	<p><b>Clutch Nut</b></p> <ul style="list-style-type: none"> <li>■ Locate special tool between clutch gear &amp; crankshaft gear to lock clutch assembly while tightening.</li> <li>■ Locate Hex nut M20 and tighten clutch assembly to counter shaft.</li> </ul>	<div data-bbox="578 1583 894 1738" style="border: 1px solid black; padding: 5px;"> <p><b>Hex Nut: M20 Socket Spanner 27mm Torque: 4-6 KgM (40-60Nm)</b></p> </div> <div data-bbox="578 1759 894 1833" style="border: 1px solid black; padding: 5px;"> <p><b>Special Tool: ST-27533-2, Crank Gears locking Tool</b></p> </div> 



S. No.	Aggregate to Assemble / Instructions	Fastener, Size, Tool Usage, Precautions, Photos
64.	<p><b>Clutch bearing with collar</b></p> <ul style="list-style-type: none"> <li>Assemble clutch bearing with collar on the clutch.</li> </ul>	
65.	<p><b>Balancer shaft bolt</b></p> <ul style="list-style-type: none"> <li>Locate small &amp; big black thrust washers on the bolt. Locate special tool between crankshaft gear &amp; clutch housing gear at the top to lock crankshaft.</li> <li>Locate Flanged hex bolt on balancer shaft and tighten</li> </ul>	<p><b>Special Tool- ST-27533-2, Crank Gears locking Tool</b></p> <p><b>Hex flange bolt: M10 X 20 Socket Spanner 14mm Torque: 4-6 KgM (40-60Nm)</b></p> 
66.	<p><b>Oil jet in Crankcase RH</b></p> <ul style="list-style-type: none"> <li>Locate 'O' ring in oil Jet.</li> <li>Insert Oil Jet into crankcase RH such that the slotted end of the jet is facing inside.</li> </ul>	<p><b>NOTE:</b></p> <p>Ensure 'O' ring is correctly located in the groove in oil jet.</p> <p>Ensure Oil jet is correctly inserted such that the slotted end is inside crankcase.</p> 
67.	<p><b>Jet crankshaft in cover RH</b></p> <ul style="list-style-type: none"> <li>Locate jet crankshaft in cover RH such that the cup end is facing outside.</li> <li>Position oil seal in cover RH such that the lip is facing towards the jet crankshaft and tap it in gently till its outer surface is flush with cover RH.</li> </ul>	<p><b>NOTE:</b></p> <p>Ensure jet crankshaft is correctly located in cover RH.</p> <p>Wrong fitment will affect oil flow into crankshaft and cause serious damage to engine.</p> 

S. No.	Aggregate to Assemble / Instructions	Fastener, Size, Tool Usage, Precautions, Photos	
67.	<p><b>Jet crankshaft in cover RH</b></p> <ul style="list-style-type: none"> <li>■ Position the plate retainer over the oil seal, align the mounting hole and tighten with hex socket head screw.</li> </ul>	<p><b>Hex socHd screw: M6X12</b>  <b>Allen Key: M5</b>  <b>Torque: 0.8-1.2KgM (8-12 Nm)</b></p>	
68.	<p><b>Cover RH</b></p> <ul style="list-style-type: none"> <li>■ Locate the 2 dowels in crankcase RH.</li>   <li>■ Position gasket on crankcase.</li>   <li>■ Ensure clutch push pad is located in Cover RH.</li> </ul>	<p><b>Note:</b></p> <p>Apply only grease on gasket to hold it in position.</p> <p><b>DO NOT APPLY</b> any adhesive or gasket sealant on the gasket to stick it to the crankcase RH as it may block the oil galleries &amp; seriously affect lubrication of engine parts.</p>	
			
			

S. No.	Aggregate to Assemble / Instructions	Fastener, Size, Tool Usage, Precautions, Photos
68.	<p><b>Cover RH</b></p> <ul style="list-style-type: none"> <li>■ Locate cover RH, on the dowels in crankcase RH and gently tap it in to seat against the gasket.</li> <li>■ Locate clutch cable guide on top of cover RH &amp; fix 1 Hex flange bolt (M6X37) at the rear of the cable guide.</li> <li>■ Fix 1 Hex flange bolt (M6X30) at the front end of cable guide.</li> <li>■ Fix 1 Hex flange bolt (M6X20) at the front top (at the recess) of cover RH.</li>   <li>■ Fix 6 Hex flange bolts (M6X37) at the rear &amp; bottom of cover RH.</li>   <li>■ Fix 4 Hex flange bolts on cover RH front.</li> <li>■ Fix 1 Hex flange bolt at front bottom of cover RH.</li> <li>■ Tighten all the 14 flange bolts diagonally to specified torque</li> </ul>	<p><b>NOTE:</b></p> <p>Ensure gasket does not get disturbed while fixing cover RH.</p> <p>Ensure cable guide is located correctly with its longer side facing forward</p> <p><b>Hex flange bolt: M6X37</b></p> <p><b>Hex flange bolt: M6X30</b></p> <p><b>Hex flange bolt: M6X20</b></p> <p><b>Hex flange bolts: M6X37</b></p> <p><b>Hex flange bolts: M6X30</b></p> <p><b>Hex flange bolt: M6X37</b></p> <p><b>Socket Spanner: 8mm</b> <b>Torque: 0.8-1.2 KgM (8-12Nm)</b></p>    

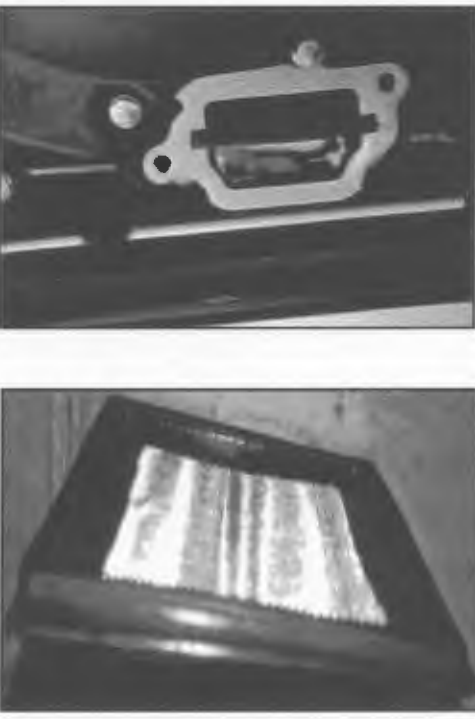
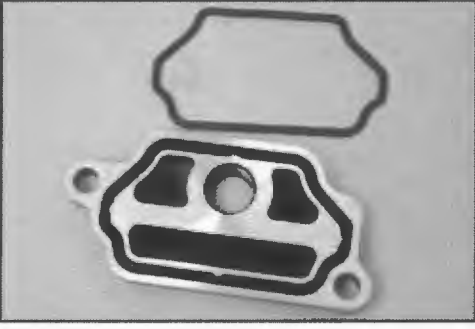
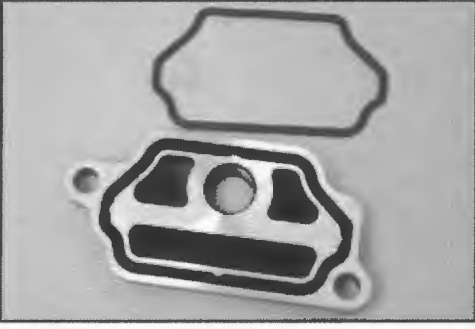

S. No.	Aggregate to Assemble / Instructions	Fastener, Size, Tool Usage, Precautions, Photos	
69.	<p><b>Oil Filter Assembly</b></p> <ul style="list-style-type: none"> <li>- 2 small Hex flange bolts at the top.</li> <li>■ Tighten all the three hex flange bolts uniformly to torque.</li> </ul>	<p><b>Hex flange bolts: M6X20</b></p>	
70.	<p><b>Oil Strainer on crankcase LH</b></p> <ul style="list-style-type: none"> <li>■ Locate strainer in crankcase LH, ensuring the thinner edge of the strainer is inserted into the crankcase.</li> </ul>	<p><b>NOTE:</b> The Oil strainer has a larger tapered face at one end as a mistake proofing for assembly. Ensure the thinner side of the strainer is inserted into crankcase for correct &amp; proper seating.</p>	
71.	<p><b>Oil Strainer cover</b></p> <ul style="list-style-type: none"> <li>■ Ensure 'O' ring is correctly positioned in oil strainer cover.</li> </ul>		

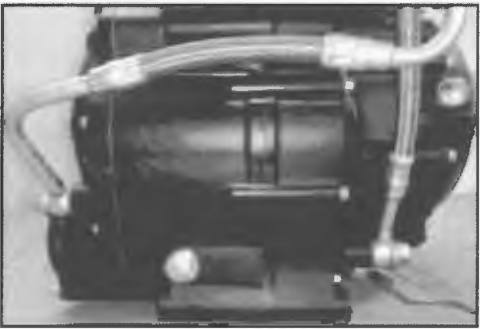
S. No.	Aggregate to Assemble / Instructions	Fastener, Size, Tool Usage, Precautions, Photos	
71.	<p><b>Oil Strainer cover</b></p> <ul style="list-style-type: none"> <li>Assemble cover such that the drain plug location is at the bottom &amp; tighten with 2 hex flange bolts.</li> </ul>	<p>Hex flange bolts: M6X20  Socket spanner: 8mm  Torque: 0.8-1.2KgM (8-12Nm)</p>	
72.	<p><b>Oil Drain Plug</b></p> <ul style="list-style-type: none"> <li>Assemble drain plug with copper washer on oil strainer cover.</li> </ul>	<p>Plug Hex: M14X12  Socket spanner: 21mm  Torque: 2-2.5KgM (20-25Nm)</p>	
73.	<p><b>Engine Oil Cooler</b></p> <ul style="list-style-type: none"> <li>Ensure the oil cooler is located correctly in the bracket in vehicle frame with 2 Hex flange bolts-</li> <li>Route the Inlet &amp; Outlet pipes between the frame &amp; engine and tighten to crankcase LH &amp; RH respectively with the 2 Banjo union bolts &amp; 4 washers.</li> </ul>	<p>Banjo Union bolts: M17  Socket Spanner: 23mm  Torque: 3.5-3.8 KgM(35-38Nm)</p> <p><b>NOTE:</b>  Ensure washers are located on both sides of the banjo unions of inlet &amp; outlet pipes before tightening.</p>	

# TROUBLE SHOOTING

It is very important for a competent and successful technician to be able to diagnose a fault correctly and first time right.

If the symptom is not diagnosed systematically and correctly, it will not only result in expensive and time consuming repairs BUT will end up with an unsatisfied customer as well. Also the fault will not be rectified, and will result in repetitive repairs.

In order to accurately troubleshoot and correctly a fault, the technician should be very thorough with:

- Each and every component of the motorcycle, its function and the effect it has on the overall performance of the motorcycle.
- Typical failures or symptoms that will occur in the event a component fails or is in the process of failure

The second most important aspect to be able to correctly troubleshoot a fault is to understand the exact nature of failure, conditions under which the failure occurs etc. Towards this it is very important to ask meaningful and correct questions to the rider of the motorcycle about the circumstances which caused the failure.

For Eg. If a motorcycle comes with a fault of engine misfiring, the technician should ask the correct questions to the rider such as

- Did the misfiring start immediately after fuel was refilled?
- Did the misfiring occur immediately after the motorcycle was water washed, used in water logged area etc.
- Was the motorcycle out of use for a prolonged period of time.
- Was the motorcycle attended to by any unauthorized / inexperienced free lance technical person/s

This will help analyze and pinpoint the most likely cause of the misfiring and help in rectifying the fault.

The third most important aspect is a careful and visual inspection with a "careful eye for detail", for any telltale signs of what could have caused the fault and then narrow down to the assembly/subassembly/ suspected part.

It is also very essential to be able to analyze and understand the nature of failure as:

- Failure due to not adhering to the periodical maintenance service schedule.
- Failure due to improper servicing by an unauthorized person
- Failure due to misuse/abuse of the motorcycle.
- Consequential failure (part failed due to malfunctioning of another part).
- New or unique failure (One off in nature)
- Premature failure of a part

Finally, a detailed and systematic inspection of the suspect assembly/subassembly/ part will help rectify the fault correctly and accurately.

The following table details symptoms, possible cause and remedy for some of the common faults that arise in a motorcycle engine. The list is not exhaustive and intended to be used only as a guide to help trouble shoot faults.

<b>1. ENGINE CRANKS BUT DOES NOT START</b>		
<b>Symptom</b>	<b>Probable Cause</b>	<b>Remedy</b>
<b>A. Ignition spark weak</b>	Battery voltage low	Recharge/ replace battery
	Spark plug cap / high tension wire loose / shorted / defective	Check & correct
	Spark plug incorrect	Replace with correct spark plug
	Spark plug sooty / wet	Check & clean spark plug
	Spark plug gap incorrect	Correct spark plug gap
	Spark plug insulator cracked	Replace spark plug
	No spark from Ignition coil	Check & Replace Ignition coil
	Pulsar coil defective	Check & Replace
	TCI Unit defective	Check & Replace
<b>B. No Ignition spark</b>	Battery dead	Recharge/ replace battery
	Spark plug cap / high tension wire shorted / defective / disconnected	Check & correct
	Spark plug insulator cracked	Replace spark plug
	No spark from Ignition coil	Check & Replace Ignition coil
	Pulsar coil defective	Check & Replace
	TCI Unit defective	Check & Replace
<b>C. Fuel related</b>	No Fuel in fuel tank	Fill fuel tank.
	Stale / adulterated fuel	Clean fuel tank Fill with fresh fuel
	Air vent blocked in fuel cap/carb.	Clean air vent/s
	Fuel filter clogged	Clean fuel filter
	Fuel line pinched	Check & correct fuel line
	Excess fuel going into induction chamber	Check & correct Float level setting
<b>D. Compression related</b>	Spark plug loose	Tighten spark plug to torque
	Tappets adjusted too tight	Check & adjust tappets to specn
	Cylinder head gasket blown	Check & replace
	Cylinder head nuts loose	Check & tighten to torque
	Cylinder head warped	Check & replace
	Valve stem bent, seating area burnt, excess carbon deposit on seating area, Valve springs broken	Check & replace
	Piston rings sticky/ worn-out	Check & replace
	Cylinder barrel / Piston excess clearance	Check & replace

<b>2. ENGINE DOES NOT CRANK</b>		
<b>Symptom</b>	<b>Probable Cause</b>	<b>Remedy</b>
<b>A. Starter motor does not rotate</b>	Ignition key not in ON position	Switch ON ignition key
	Engine Kill switch in OFF position	Switch ON engine Kill switch
	Gears not in neutral (neutral lamp not glowing)	Depress clutch / shift to correct neutral & start
	Battery voltage low	Check battery. Recharge replace battery
	Starter circuit Fuse blown	Check all fuses & replace blown fuse
	Starter motor connections loose	Check & tighten connections
	Starter relay connections loose	Check & tighten connections
	Ignition Switch defective	Check & replace Ignition switch
	Starter button defective	Check & replace RH switch.
	Starter relay failed	Check & replace starter relay
	Starter motor failed	Check & replace starter motor
Major short in Wiring harness	Check & correct wiring harness	
<b>B. Starter motor rotates BUT engine does not crank</b>	Motor rotates slowly due to low battery / worn out starter motor brush	Check & correct battery / starter motor
	Magneto rotor woodruff key broken	Check & replace woodruff key
	Starter clutch assembly slipping	Check & replace starter clutch assy
<b>C. Engine does not crank and sounds locked.</b>	Inlet/ Exhaust rocker arm seized in rocker shaft	Investigate cause of seizure, check & correct as required
	Cam shaft seized in cylinder head/cover	Investigate cause of seizure, check & correct as required
	Cam chain jammed in sprocket gears	Investigate cause of seizure, check & correct as required
	Piston Seized in cylinder barrel	Investigate cause of seizure, check & correct as required
	Piston Pin seized in connecting rod small end	Investigate cause of seizure, check & correct as required
	Big end bearing seized in Crank pin / connecting rod big end	Investigate cause of seizure, check & correct as required
	Crankshaft bearings in LH/RH crankcases seized	Investigate cause of seizure, check & correct as required

<b>3. IDLING ERRATIC / ENGINE MISFIRING AT LOW RPM</b>		
<b>Attribute</b>	<b>Probable Cause</b>	<b>Remedy</b>
<b>A. Ignition related</b>	Battery voltage low	Recharge/ replace battery
	Suppressor cap/ H T lead loose	Check & correct as required
	Suppressor cap/ H T lead defective	Check & correct as required
	Spark plug fouled / wet	Replace / clean spark plug
	Electrode gap too less/excessive	Check and correct electrode gap
	Spark plug wrong specifications	Replace with correct spark plug
	Ignition coil defective	Check & replace
	Pulsar coil / Magneto defective	Check & replace
<b>B. Fuel/ Induction related</b>	Adulterated / Bad fuel	Clean fuel tank. Fill with fresh fuel
	Air vent holes in Fuel tank cap	Check & clean air vents
	Fuel flow partially blocked	Check & clean fuel filter
	Air filter dirty / clogged	Check & clean / replace
	Inlet manifold loose	Check & correct
	Pilot Jet loose / partially blocked	Check & correct
	Pulse air valve pipe connections loose / cracked	Check & correct
<b>C. Compression related</b>	Spark plug loose	Check & tighten to torque
	Inlet / Exhaust tappets adjusted wrongly	Check & correct
	Cylinder head gasket blown	Check & correct
	Cylinder head studs loose	Check & tighten to torque
	Cylinder head seating area warped	Check & replace
	Cam shaft sticky rotation /seized in cylinder head	Check & correct
	Valve spring broken or weak	Check & replace
	Valve not seating properly (stem bent. Heavy carbon deposit on seating surface)	Check & replace
	Piston rings worn out/ broken / stuck in ring groove	Check & replace
	Cylinder / piston worn	Check & replace

#### 4. PICKUP POOR / SLUGGISH

Attribute	Probable Cause	Remedy
<b>A. Ignition related</b>	Suppressor cap/ H T lead defective	Check & correct as required
	Spark plug fouled / wet	Replace / clean spark plug
	Electrode gap too less/excessive	Check and correct electrode gap
	Spark plug wrong specifications	Replace with correct spark plug
	Ignition coil defective	Check & replace
	Pulsar coil / Magneto defective	Check & replace
<b>B. Fuel/Induction related</b>	Adulterated / Bad fuel	Clean fuel tank. Fill with fresh fuel
	Air vent holes in Fuel tank cap partially blocked	Check & clean air vents
	Fuel flow partially blocked	Check & clean fuel filter
	Air filter dirty / clogged	Check & clean / replace
	Fuel level bowl too high or too low	Check & correct float level
	Inlet manifold loose	Check & correct
	Pilot Jet loose / partially blocked	Check & correct
	Main jet clogged / wrong size	Check & replace
	Jet needle / needle jet worn out	Check & replace
	Diaphragm damaged	Check & replace
	Pulse air valve pipe connections loose / cracked	Check & correct
<b>C. Compression related</b>	Spark plug loose	Check & tighten to torque
	Inlet / Exhaust tappets adjusted wrongly	Check & correct
	Cylinder head gasket blown	Check & correct
	Cylinder head studs loose	Check & tighten to torque
	Cylinder head seating area warped	Check & replace
	Cam shaft sticky rotation / seized in cylinder head	Check & correct
	Valve spring broken or weak	Check & replace
	Valve not seating properly (stem bent. Heavy carbon deposit on seating surface)	Check & replace
	Piston rings worn out/ broken / stuck in ring groove	Check & replace
	Cylinder / piston worn	Check & replace
<b>D. Transmission related</b>	Rear chain tension too slack / tight	Check & correct
	No free play in clutch / clutch release sticky	Check & correct
	Engine oil quantity too high	Check & correct
	Engine oil wrong grade/ high viscosity	Check & correct
	Clutch plates worn out / warped / sticky release / burnt	Check & correct
<b>E. Others</b>	Front / rear brakes jamming	Check & correct
	Front / rear wheel bearing jammed	Check & correct

## 5. ENGINE MISFIRING AT HIGH SPEEDS/ HIGH RPM.

Attribute	Probable Cause	Remedy
<b>A. Ignition related</b>	Spark plug electrode gap too less/ excessive	Check and correct electrode gap
	Spark plug wrong specifications	Replace with correct spark plug
	Spark plug insulator cracked	Check & replace
	Suppressor cap/ H T lead loose	Check & correct as required
	Suppressor cap/ H T lead defective	Check & correct as required
	Ignition coil defective	Check & Replace
	TCI defective	Check & replace
	Pulsar coil / Magneto defective	Check & replace
<b>B. Fuel/Induction related</b>	Adulterated / stale fuel / water content in fuel	Check, Clean fuel tank/ Fill with fresh fuel
	Air vent holes in Fuel tank cap	Check and clean air vents
	Fuel flow partially blocked	Check & clean fuel filter
	Inlet manifold loose / cracked	Check & tighten / replace
	Fuel level bowl too high or too low	Check & correct float level
	Main jet clogged / wrong size	Check & replace
	Jet needle / needle jet worn out	Check & replace
<b>C. Compression Related</b>	Spark plug loose	Tighten spark plug to torque
	Tappets adjusted too tight	Check & adjust tappets correctly
	Cylinder head bolts loose	Check & tighten to torque
	Cylinder head gasket damaged	Check & Replace
	Cylinder head warped	Check & Replace
	Valve spring broken or weak	Check & Replace
	Valve not seating properly (valve bent, worn, carbon accumulation on the seating surface.)	Check & Replace
	Excessive Carbon in combustion chamber	Check & Clean
	Piston ring bad (worn, weak, broken, or sticking)	Check & Replace
	Piston rings clearance excessive	Check & Replace
Cylinder, piston worn	Check & Replace	

<b>6. EXHAUST SMOKE EXCESS</b>		
<b>Symptom</b>	<b>Probable Cause</b>	<b>Remedy</b>
<b>A. Blacksmoke</b>	Adulterated / Bad fuel	Clean fuel tank. Fill with fresh fuel
	Spark plug Electrode gap too less	Check and correct electrode gap
	Spark plug wrong specifications	Replace with correct spark plug
	Fuel level bowl too high (overflowing)	Check & correct float level in
	Air Filter element clogged	Check & Clean
	Pulse air valve pipe connections loose / cracked	Check & correct
	Main jet loose / too large	Check, correct / replace
	Jet needle worn out/ wrong size	Check & replace
	Ignition coil defective	Check & replace
<b>B. Brown smoke</b>	Adulterated / Bad fuel	Clean fuel tank. Fill with fresh fuel
	Fuel level bowl too low	Check & correct
	Air filter box poorly sealed / element partially clogged	Check & correct
	Main jet too small	Check & replace
<b>C. Bluish/Whitesmoke</b>	Engine oil level too high	Check & Maintain Oil level as Recommended
	Valve stem seal damaged	Check & correct
	Excess clearance between valve stem & guide	Check & correct
	Oil scrapper ring worn out	Check & correct
	Cylinder barrel / piston clearance high	Check & replace

<b>7. ENGINE HEAT EXCESSIVE</b>		
<b>Attribute</b>	<b>Probable Cause</b>	<b>Remedy</b>
<b>A. Driving/trafficrelated</b>	Prolonged driving in low gear at High speeds / High gear at Low speeds	Ride in appropriate gear as required by traffic conditions
	Engine in Idling RPM for prolonged periods	Switch off Engine if required to be in standstill traffic for more than 2 minutes.
	Vehicle in standstill with gear engaged and clutch depressed for prolonged periods	Shift to neutral & release clutch
	Engine RPM high when vehicle at standstill position	Allow engine to run in idling RPM when in neutral
	Riding in traffic with brakes partially engaged for prolonged periods	Release both brakes and drive at appropriate speeds
<b>B. Ignition Related</b>	Spark plug electrode gap too less/excessive	Check and correct electrode gap
	Spark plug wrong specifications	Replace with correct spark plug
	Spark plug insulator cracked	Check & replace
	Suppressor cap/ H T lead loose	Check & correct as required
	Suppressor cap/ H T lead defective	Check & correct as required
	Ignition coil defective	Check & Replace
	TCI defective	Check & replace
Pulsar coil / Magneto defective	Check & replace	
<b>C. Fuel/Inductionrelated</b>	Adulterated / Bad fuel	Clean fuel tank. Fill with fresh fuel
	Air filter dirty / clogged	Check & clean / replace
	Improper fuel level	Check & correct
	Inlet manifold loose	Check & correct
	Main jet clogged / wrong size	Check & replace
	Jet needle / needle jet worn out	Check & replace
<b>D. Compression Related</b>	Pulse air valve pipe connections loose / cracked	Check & correct
	Spark plug loose	Tighten spark plug to torque
	Tappets adjusted too tight	Check & adjust tappets correctly
	Excessive Carbon in combustion chamber	Check & Clean
<b>E. Others</b>	Poor compression due to cyl. head gasket blown, Valve seating improper, Piston rings worn out / broken, Piston/Cyl. worn out	Check & correct
	Engine oil less viscous / wrong specification / level too low	Check & correct
	Oil cooler fins dirty / blocked	Check & clean oil cooler fins
	Clutch slipping	Check & correct
	Front / Rear brakes jammed	Check & correct
	Engine oil pressure less	Check & correct
Silencer choked	Check & clean	

<b>8. ENGINE NOISY</b>		
<b>Attribute</b>	<b>Probable Cause</b>	<b>Remedy</b>
<b>A. Knocking noise</b>	Prolonged driving in low gear at High speeds / High gear at Low speeds	Ride in appropriate gear as required by traffic conditions
	Excessive Engine heat	Check & correct
	Adulterated / Bad fuel	Clean fuel tank. Fill fresh fuel
	Incorrect plug gap. Wrong spec spark plug	Check & correct gap
	Excessive carbon in combustion chamber	Check & correct
	Pulse air valve pipe connections loose / cracked	Check & correct
<b>B. Lubrication related</b>	Exhaust pipe & cylinder head joint not sealed correctly	Check & tighten exhaust flange nuts / replace gasket
	Engine oil less viscous/wrong specification / level too low	Check & correct
	Oil filter element blocked	Replace filter element
<b>C. TopEnd noise</b>	Oil pressure low	Check & correct
	Tappets clearance excessive correctly	Check & adjust tappets
	Camshaft sticky rotation	Check & correct
	Cam lobes in camshaft uneven wear	Check & replace
	Cylinder head gasket blown	Check & replace
	Valve spring broken / weak	Check & replace
	Valve stem squeaky noise	Replace stem seals
<b>D. Cylinder barrel/central portion noise</b>	Valve stem to guide clearance high	Check & replace
	Piston rings broken	Check & replace
	Cylinder / Piston scored / housing also for damages	Check & replace. Check air filter
	Excess clearance between piston / barrel (Piston slap)	Check & replace
	Cam chain pads worn out	Check & replace
	Auto chain tensioner jammed	Check & replace
	Excessive clearance between Cam chain / sprockets	Check & replace
	Connecting rod small end / piston pin clearance excess	Check & replace
<b>E. Bottom end noise</b>	Connecting rod bent	Check & replace crankshaft
	Excess clearance between connecting rod big end / crank pin	Check & replace crankshaft
	Crankshaft / balancer shaft support bearings worn	Check & replace
	Crankshaft run out excessive	Check & replace
	Balancer shaft / crankshaft gears backlash	Check & correct
<b>F. Transmission noise</b>	Clutch housing/friction plate clearance excessive	Check & replace
	Clutch housing gear / crank gear backlash	Replace matched gears
	Drive / counter gears backlash	Check & replace
	Drive / Countershaft bearings worn out	Check & replace
	Gears / bushes seized in drive /counter shaft	Check & replace

<b>9. GEAR SHIFTING HARD / SLIPS</b>		
<b>Attribute</b>	<b>Probable Cause</b>	<b>Remedy</b>
<b>A. Clutch cable related</b>	Routing improper	Check & correct
	Strapped too tight to frame	Check & correct
	Inner cable sticky	Check & replace
	Inner/outer cable damaged	Check & replace
	Free play excess	Correct free play to 2-3mm
<b>B. Oil related</b>	Oil less / more viscous. Wrong specification	Check & correct
	Oil level too high / too low	Check & correct
<b>C. Shift lever / linkage / shifting Mechanism related</b>	Gear lever position incorrect	Check & correct
	Shift lever sticky / jammed on pivot pin	Check, clean & lubricate pivot pin
	Gear shift linkage ball joint stuck/worn out	Check & correct
	Return spring weak / broken	Check & replace
	Indexing pawl pins worn out	Check & replace
	Shift forks sticky in pin / selector drum	Check & correct
	Shift forks / pins worn out	Check & replace
	Selector drum grooves worn out	Check & replace
<b>D. Clutch assembly related</b>	Clutch pad sticky / worn out	Check & replace
	Clutch plates movement sticky	Check & correct
	Springs weak / broken	Check & replace
	Friction plates worn out / burnt	Check & replace
	Steel plates warped	Check & replace
	No end float of clutch assembly in shaft	Check & correct
<b>E. Gears does not engage</b>	Shift forks sticky in pin / selector drum	Check & correct
	Selector drum rotation sticky	Check & correct
	Sliding gear movement sticky in shaft	Check & correct
	Gears / bushes partially seized in shaft	Check & correct
<b>F. Gear overshifts</b>	Shift forks / pins worn out	Check & replace
	Selector drum grooves worn out	Check & replace
	Sliding Gear dogs worn out	Check & replace
	Drive shaft / counter shaft splines worn out	Check & replace
	Drive / counter shaft bearings wornout	Check & replace

ROYAL ENFIELD

Royal Enfield Support : 1800-2100-007

Email : [support@royalenfield.com](mailto:support@royalenfield.com)

Twitter : [@RoyalEnfieldSupport](https://twitter.com/RoyalEnfieldSupport)

Web : [www.royalenfield.com](http://www.royalenfield.com)