

Harley-Davidson

SERVICE MANUAL

Early 1978

Electra Glide - FL/FLH - 1200

Super Glide - FX/FXE/FXS - 1200

1970 to

PART NO. 99482-78

FOREWORD

This service and repair manual has been prepared with two purposes in mind. First, it will acquaint the reader with the construction of the Harley-Davidson product and assist him in performing basic maintenance and repair. Secondly, it will introduce to the professional Harley-Davidson mechanic the latest field-tested and factory-approved major repair methods. We sincerely believe that this manual will make your association with Harley-Davidson products more pleasant and profitable.

HOW TO USE YOUR SERVICE MANUAL

Your Service Manual is arranged for quick, easy reference. This manual is divided into numbered sections entitled "Chassis," "Engine" and "Transmission." Sections are then divided into sub-sections. The Engine Section, for example is comprised of "Cylinder" and "Crankcase" sub-sections.

Use this manual as follows:

1. Check the Table of Contents located in the front of each section to find subject desired.
2. Page number is listed across from subject.
3. Each section is printed with section number for quick general location of subject. Page number consists of section number and page number.
4. Information is presented in a definite order as follows:
 - Minor adjustments
 - Minor maintenance or repair
 - Complete disassembly
 - Cleaning
 - Major maintenance or repair
 - Assembly

In figure legends the number following a name of a part indicates the quantity necessary for one complete assembly.

All information for servicing a part should be read before repair work is started to avoid needless disassembly.

SERVICE BULLETINS

In addition to the information given in this Service Manual, Service Bulletins are issued to Harley-Davidson Dealers from time to time, which cover interim engineering changes and supplementary information. Service Bulletins should be consulted for complete information on the models covered by this manual.

USE GENUINE REPLACEMENT PARTS

To insure a satisfactory and lasting repair job, follow the manual instructions carefully and use only genuine Harley-Davidson replacement parts. Behind the emblem bearing the words "Genuine Harley-Davidson" is more than half a century of designing, research, manufacturing, testing and inspecting experience.

This is your insurance that the parts you are using will fit right, operate properly and last longer. When you use genuine Harley-Davidson parts, you use the best.

WARNING — Gasoline is extremely flammable and highly explosive under certain conditions. Always stop engine, and do not smoke or allow open flame or sparks when refueling or servicing the fuel system, or when using gasoline as a cleaning solvent where specified in this manual.

1970 to Early 1978

**ELECTRA GLIDE
FL/FLH 1200**

**SUPER GLIDE
FX/FXE/FXS 1200**

**SERVICE
MANUAL**

PRODUCT

1

CHASSIS

2

ENGINE

3

TRANSMISSION

4

ELECTRICAL

5

MISCELLANEOUS

6

The maintenance and repair information in this manual applies to the 1970 through early 1978 (up to January 1, 1978 production) Electra Glide/Super Glide Models FL/FLH/FX/FXE/FXS-1200.

COPYRIGHT 1978 BY HARLEY-DAVIDSON MOTOR CO., INC. ALL RIGHTS RESERVED

PART NO. 99482-78

HG-5M 4/82-R

TABLE OF CONTENTS

	Page Number		Page Number		Page Number
PRODUCT		HANDLEBAR		ENGINE	
SPECIFICATIONS		Spiral Type	2-19	GENERAL	
Dimensions	1-1	Disassembling and Assembling	2-19	Specifications	3-1
Capacities	1-1	Drum Type	2-20	Description	3-1
Engine	1-1	Disassembling and Assembling	2-20	Lubrication	3-2
Transmission	1-1			Repair and Diagnostic Procedure	3-7
Sprockets and Gear Ratios	1-1	FRAME	2-21		
Tire Data	1-2			CYLINDER HEAD	
SERVICE		FORKS		Removing	3-11
Servicing a New Motorcycle	1-3	Changing Oil	2-23	Disassembling	3-11
TORQUE REQUIREMENTS		FL Front Fork	2-24	Cleaning and Inspection	3-11
Chassis Components	1-5	Inspection Procedure	2-24	Repairing Rocker Arms and Bearings	3-11
Engine Components	1-5	Adjusting and Disassembling	2-27	Valves, Valve Seats and Guides	3-11
Electrical Components	1-5	Repairing	2-27	Assembling Cylinder Head	3-14
Regular Service	1-6	Assembling	2-29	Adjusting Tappets	3-14
Lubricants	1-15	FX Front Fork	2-29		
LOCATING TROUBLES		Inspection Procedure	2-29	CYLINDER AND PISTON	
Engine	1-17	Disassembling	2-31	Disassembling	3-15
Lubrication System	1-18	Repair	2-31	Cleaning and Inspecting	3-15
Electrical System	1-18	Assembling	2-34	Refinishing Cylinders	3-16
Carburetor	1-18	Rear Shock		Fitting Piston Rings	3-17
Transmission	1-18	Absorbers	2-36	Connecting Rod Bushing	3-18
Clutch	1-19	Rear Fork	2-38	Straightening Connecting Rods	3-18
Brakes	1-19			Assembling Cylinder and Piston	3-19
CHASSIS		BRAKES		GEARCASE	
DRIVE		Front Drum Brake	2-39	Oil Pump	3-21
Chains	2-1	Adjusting	2-39	Disassembling	3-21
Front and Rear		Disassembling	2-39	Assembling	3-22
Chain Adjustment	2-1	Servicing	2-40	Valve Tappets and Guides	3-23
Rear Chain Lubrication	2-2	Assembling	2-40	Disassembling	3-23
Cleaning Chain Oiler	2-2	Rear Drum Brake	2-41	Cleaning and Inspecting	3-23
Removing and Installing		Adjusting	2-41	Hydraulic Units	3-23
Rear Chain	2-3	Disassembling	2-42	Assembling	3-23
Removing and Installing		Servicing	2-42	Gearcase Timing Gears	3-24
Front Chain	2-3	Assembling	2-43	Disassembling	3-24
WHEELS		Sidecar Wheel Brake	2-43	Cleaning and Inspecting	3-24
Removing and Installing		Disc Brake	2-43	Replacing Cover	
Front Wheels	2-5	Check List	2-43	Bushings	3-26
Rear Wheel	2-7	Disassembly and Reassembly	2-43	Assembling	3-26
Sidecar Wheel	2-8	Front Disc Brake		CRANKCASE	
Wheel Hub and Brake		Master Cylinder	2-48	General	3-29
Drum or Disc	2-9	Disassembling and Assembling	2-48	Disassembling Crankcase	3-29
Sprocket Replacement	2-13	Rear Brake Master Cylinder	2-49	Flywheels	3-30
Spoking Wheels - 16 Inch	2-13	Disassembling and Assembling	2-49	Assembling Crankcase	3-36
Spoking Front Wheel - 19 Inch	2-14	Hydraulic System	2-49		
Truing Wheels	2-15	SEAT	2-51		
Removing and Mounting		FIBERGLASS	2-55		
Tire on Rim	2-16	Body Care and Repairs	2-55		
Checking Tire Trueness	2-17	TOOLS	2-61		
Wheel Alignment	2-18				

TABLE OF CONTENTS (cont'd)

	Page Number		Page Number		Page Number
FUEL SYSTEM		KICK STARTER		1974 FX/FXE 1200	
Tillotson Carburetor -		Disassembling and		Wiring Diagram Key	5-14
1970 Models	3-39	Assembling	4-9	1974 FX/FXE 1200	
Description	3-39			Wiring Diagram	5-15
Operation	3-40	GEAR BOX		1975 FL/FLH 1200	
Adjusting	3-42	Adjusting Shifting		Wiring Diagram Key	5-16
Inspecting and Testing	3-43	Linkage	4-11	1975 FL/FLH 1200	
Disassembling	3-45	Main Drive Gear		Wiring Diagram	5-17
Cleaning and Repairing	3-45	Oil Seal	4-11	1975 FX/FXE 1200	
Assembling	3-47	Shifter Cover	4-12	Wiring Diagram Key	5-18
Troubleshooting	3-47	Shifter Cover (Hand		1975 FX/FXE 1200	
Bendix Carburetor -		Shift)	4-13	Wiring Diagram	5-19
1971-1975 Models	3-48	Shifter Cover (Foot		1976 to 1977	
Description	3-48	Shift)	4-13	FL/FLH 1200	
Operation	3-48	Shifter Forks	4-16	Wiring Diagram Key	5-20
Adjusting	3-49	Gear Box (Four Speed)		1976 to 1977	
Disassembling	3-50	Disassembling	4-17	FL/FLH 1200	
Cleaning and Inspection	3-50	Cleaning and Repair	4-20	Wiring Diagram	5-21
Assembling	3-50	Assembling	4-21	1976 to 1977	
Keihin Carburetor - 1976		Disassembling and		FX/FXE 1200	
and Later Models	3-52	Assembling Gear Box		Wiring Diagram Key	5-22
Description	3-52	(Three Speed and		1976 to 1977	
Operation	3-52	Reverse)	4-21	FX/FXE-1200	
Adjusting Carburetor	3-54	TOOLS	4-23	Wiring Diagram	5-23
Disassembling	3-54			1978 FL/FLH 1200	
Cleaning & Inspection	3-54	ELECTRICAL		Wiring Diagram Key	5-24
Assembling Carburetor	3-56	GENERAL		1978 FL/FLH 1200	
Installing Carburetor		Specifications	5-1	Wiring Diagram	5-25
on Motorcycle	3-56	WIRING		1978 FX/FXE 1200	
Keihin Carburetor		1970 FL/FLH		Wiring Diagram Key	5-26
Troubleshooting	3-57	Diagram Key	5-2	1978 FXS 1200	
Air Cleaner	3-59	1970 FL/FLH		Wiring Diagram Key	5-28
Fuel Tank	3-59	Diagram	5-3	1978 FXS 1200	
Fuel Supply Valve	3-59	1971 FL/FLH		Wiring Diagram	5-29
TOOLS	3-61	Diagram Key	5-4	SWITCHES	
TRANSMISSION		1971 FL/FLH		Ignition-Light Switch	5-30
GENERAL		Diagram	5-5	Handlebar Switch	
Specifications	4-1	1971 FX/FXE		1970-1971	5-31
Description	4-1	Diagram Key	5-6	Handlebar Switch	
Stripping Motorcycle for		1971 FX/FXE		1972 and Later	5-31
Transmission Repair	4-1	Diagram	5-7	Transmission Neutral	
CLUTCH		1972 FL/FLH		Switch	5-32
General	4-3	Diagram Key	5-8	Solenoid Switch	5-32
Controls	4-3	1972 FL/FLH		Starter Relay Switch	5-33
Disassembling	4-3	Diagram	5-9	Stop Lamp Front	
Cleaning and Inspection	4-6	1973-74 FL/FLH 1200		Brake Switch	5-33
Assembling	4-6	Wiring Diagram Key	5-10	Stop Lamp Rear	
ELECTRIC STARTER		1973-74 FL/FLH 1200		Brake Switch	5-33
General	4-7	Wiring Diagram	5-11	LAMPS	
Disassembling and		1973 FX 1200 Wiring		Headlamp	5-35
Assembling	4-7	Diagram Key	5-12	Adjusting Beam	5-35
		1973 FX 1200 Wiring		Bulb Chart	5-35
		Diagram	5-13		

TABLE OF CONTENTS (cont'd)

	Page Number		Page Number		Page Number
CHARGING SYSTEM		CHECKING CHARGING		BATTERY	
1975 & EARLIER	5-37	SYSTEM	5-44	General	5-55
Alternator	5-37	Disassembling, Cleaning		Care	5-55
Rotor	5-37	and Inspecting and		Charging	5-56
Stator	5-37	Assembling Alternator	5-45		
Rectifier-Regulator	5-37	CIRCUIT BREAKER		HORN	5-57
		Description	5-47		
		Operation	5-47		
CHECKING CHARGING		Troubleshooting	5-47	STARTER MOTOR	
SYSTEM	5-38	Adjusting Points	5-48	Troubleshooting	5-59
Disassembling Alternator	5-40	Ignition Timing	5-48	Prestolite	5-59
Cleaning and Inspecting		Disassembling	5-49	Disassembling and	
Alternator	5-40	Assembling	5-50	Assembling	5-59
Assembling Alternator	5-40	IGNITION COIL		Hitachi	
		Description	5-51	Disassembling and	
		Troubleshooting	5-51	Assembling	5-61
		Replacing Cables	5-51		
CHARGING SYSTEM		SPARK PLUGS		TOOLS	5-63
1976 & LATER	5-43	General	5-53		
Alternator	5-43	Removing Plugs	5-53		
Rotor	5-43	Cleaning, Inspection		MISCELLANEOUS	
Stator	5-43	and Repair	5-53	INSTRUMENTS	
		Setting Spark Gap	5-54	Speedometer	6-1
TYMPANIUM RECTIFIER-		Testing Spark Plugs	5-54	Tachometer	6-1
REGULATOR	5-43	Installing Spark Plugs	5-54		

TABLE OF CONTENTS

	PAGE
General	1-1
Service	1-3
Torque Requirements	1-5
Fluid Requirements	1-15
Locating Troubles	1-17

GENERAL

SPECIFICATIONS

NOTE

Model FL specifications also apply to model FLP unless otherwise stated.

DIMENSIONS

	FL/FLH	FX	FXS
Wheel Base	61.0 in.	63.0 in.	63.5 in.
Overall Length	89.0 in.	92.0 in.	92.0 in.
Overall Width	39.0 in.	34.0 in.	29.0 in.
Overall Height	43.5 in.	45.75 in.	41.75 in.

CAPACITIES

		Total	Reserve
Fuel Tanks:	FL/FLH	5 or 3.5	1.2 or 1
(U.S. Gal.)	FX/FXE 1973-74	3.6	0.7
	FX/FXE 1975 & Later	3.6	0.6
	FXS	3.5	1.0

Oil Tank	4 Quarts (U.S.)
Transmission	1-1/2 Pints (U.S.)

ENGINE

Model Designation Letters	FL - FLH
Number of Cylinders	2
Type	4 Cycle, 45 Degree V Type
Horsepower	FLH - 62.0 hp at 5400 rpm FL - 57.0 hp at 5200 rpm
Taxable Horsepower	9.44
Bore	(87.3 mm) 3.438 in.
Stroke	(100.8 mm) 3.968 in.
Piston Displacement	(1207 cc) 73.66 cu in.
Torque	FLH - 70 lb-ft at 3900 rpm FL - 64 lb-ft at 3600 rpm
Compression Ratio	FLH - 8 to 1 FL - 7.25 to 1
Spark Plug (Heat range for average use)	
1974 & Earlier	No. 3-4
1975 & 1976	No. 5-6
1977 & Later	No. 5A6 (Standard) No. 5R6 (Resistor)

NOTE

The Vehicle Identification Number (V.I.N.) is stamped on the right side of the engine crankcase and frame steering head. It consists of a model code, a serial number, a manufacturer's identification and model year as shown in the table.

Letters	Model No.	Serial No.	Mfr.	Year
FL or FLP	1A	10,000	H	8
FLH	2A	and up	Harley-	(1978)
FX	2C	(5 digits)	Davidson	
FXE	9D			
FXS	2F			

Always give this number when ordering parts or making an inquiry.

TRANSMISSION

Type Constant Mesh

Internal Ratios:

	4 Forward		3 Forward
	FX/FXE		1 Reverse
	1974 & Earlier	1975 & Later	
1st	3.00	3.00	2.45
2nd	1.82	1.82	1.50
3rd	1.23	1.23	1.00
4th or reverse	1.00	1.00	2.66

Engine Sprocket Teeth	24, 23, 22, 19
Clutch Sprocket Teeth	37
Transmission Sprocket Teeth	FL/FLH - 22 FX/FXE/FXS - 23
Rear Wheel Sprocket Teeth	51

SPROCKETS AND GEAR RATIOS

Overall Gear Ratios	Engine Sprocket											
	4 Speed						3 Speed					
	24		23		22		24	23	22	19		
	FL/FLH	FX	FL/FLH	FX	FL/FLH	FX	FLH	FL	FLH	FL		
1st (Low)	10.74	10.25 8.38	11.19	10.71 8.75	11.69	11.20 9.14	9.69	10.01	10.57	12.20		
2nd	6.50	6.24	6.79	6.51	7.09	6.80	5.36	5.60	5.84	6.75		
3rd	4.39	4.21	4.59	4.40	4.79	4.60	3.57	3.73	3.90	4.50		
4th or Reverse	3.57	3.42	3.73	3.57	3.90	3.73			10.37	11.97		

WARNING — Tires and tubes are correctly matched to wheel rims as specified below to provide a safe installation and must be used exclusively for replacement. The use of an incorrect tire or tube could cause damage resulting in tire deflation and/or affect motorcycle handling leading to an accident.

Tire identification numbers and size are given on the tire sidewall. Tube sizes are printed on the tube. Protective rubber rim strips must be used on spoked wheels.

Wheel	Wheel Description	Tube Size (Goodyear)	Tire Size (Goodyear)
16 Inch	Cast, 7 Spoke	MT90-16CV*	MT90-16T 5.00-16T 5.10-16T
	Laced		
FL/FLH Front & Rear FX/FXE/FXS Rear	Cast, 16 Spoke	G5.10-16	
	Cast, 9 Spoke		
19 Inch	Laced	V18/19	3.75-19T MM90-19T
	Cast, 7 Spoke Cast, 9 Spoke	V18/19	MJ90-19

* MT90-16CV is a center valve tube.

The following tire inflation pressures are based on rider and passenger weights of approximately 150 lbs each. For each 50 lbs extra weight, increase pressure of rear tire 2 lbs, front tire 1 lb, and sidecar tire 1 lb.

		Tire Pressure — PSI (Cold)		
		Front	Rear	Sidecar
Solo rider	FL/FLH	20	24	
	FX/FXE/FXS	24	26	
Rider and one passenger	FL/FLH	20	26	
	FX/FXE/FXS	24	28	
Rider and one sidecar passenger or 150 lbs.	(FL/FLH Only)	22	26	20

WARNING — The maximum cold inflation pressure of these tires is 32 lbs.

SERVICE

SERVICING A NEW MOTORCYCLE

PRE-DELIVERY

Service operations to be performed before delivery to customer are specified in the Pre-delivery and Setting Up Instructions and Important Instructions included with new vehicle.

CHECK AT FIRST 500 MILES

1. Drain oil tank through drain plug, flush with kerosene and refill with fresh oil.
2. Replace oil filter. Clean overhead valve/tappet oil supply screen.
3. Drain transmission through drain plug and refill to level of filler opening with fresh oil. Use same grade oil used in engine.
4. Lubricate all points indicated for 1000 mile attention in the regular service intervals chart.
5. Aim headlight.
6. Inspect and service air cleaner if needed.
7. Check adjustment of chains and readjust if necessary.
8. Check lubrication of rear chain and readjust chain oiler (if provided).
9. Check wheel and brake disc mounting bolts and tighten if needed. These bolts must be tightened to specified torque.
10. Check level of solution in battery and add distilled water if needed. See that terminals are clean and connections tight.
11. Check tightness of all cylinder head bolts and all cylinder base nuts, and tighten where necessary to specified torque.
12. Check brake adjustment, hydraulic fluid level and hydraulic line connections for leakage.
13. Check tire pressure and inspect tread.
14. Check front and rear fork bearing adjustment.
15. Check carburetor controls and adjustment.
16. Inspect brake pad linings and brake disc.
17. Check oil lines and fittings for leaks.
18. Inspect and clean spark plugs.
19. Check ignition timing and circuit breaker point condition and gap.

20. Check all nuts, bolts and screws, and tighten any found loose to specified torque.
21. Check and tighten wheel spokes.
22. Check clutch adjustment.
23. Change Model FX 1200 front fork with recommended oil.
24. Road test.

CHECK AT FIRST 1000 MILES







1. Drain oil tank and refill with fresh oil.
2. Replace oil filter.
3. Check level of oil in transmission and add oil if needed. Use same grade of oil used in engine.
4. Service air cleaner.
5. Check adjustment of chains and adjust if necessary.
6. Check lubrication and condition of front chain, and check chaincase vacuum with gage, Part No. 96950-68.
7. Check lubrication and condition of rear chain and readjust chain oiler if necessary.
8. Check level of solution in battery, and add distilled water if needed. See that terminals are clean and connections tight.
9. Check circuit breaker point gap and condition and adjust if necessary.
10. Check brake adjustment and hydraulic fluid levels.
11. Check clutch adjustment.
12. Check tire pressure and inspect tread.
13. Check all nuts, bolts and screws, and tighten any found loose to specified torque.
14. Check and tighten spokes.
15. Check carburetor controls and adjustment.
16. Lubricate all controls and fittings.
17. Inspect brake linings and discs.
18. Road test.

Above operations are described fully in section pertaining to particular part of motorcycle. See table of contents for location.

TORQUE REQUIREMENTS

GENERAL FASTENER TIGHTENING SPECIFICATIONS

Torque specifications for specific components are listed below. For all other fasteners, use the values listed in the table below. Torque figures are in ft-lbs except those marked with an asterisk (*) which are in in-lbs.

FASTENER	TYPE	MINIMUM TENSILE STRENGTH	MATERIAL	Body Size or Outside Diameter																	
				2	3	4	5	6	8	10	1/4	3/8	1/2	3/4	1	1 1/8					
	SAE 2 STEEL	74,000 PSI	LOW CARBON									6	12	20	32	47	69	96	155	206	310
	SAE 5 STEEL	120,000 PSI	MEDIUM CARBON HEAT TREAT							14*	22*	10	19	33	54	78	114	154	257	382	587
	SAE 7 STEEL	133,000 PSI	MEDIUM CARBON ALLOY									13	25	44	71	110	154	215	360	570	840
	SAE 8 STEEL	150,000 PSI	MEDIUM CARBON ALLOY									14	29	47	78	119	169	230	380	600	700
	SOCKET HEAD CAP SCREW	160,000 PSI	HIGH CARBON QUENCHED TEMPERED									16	33	54	84	125	180	250	400	640	970
	SOCKET SET SCREW	212,000 PSI	HIGH CARBON QUENCHED TEMPERED							9*	16*	30*	70*	140*	18	29	43	63	100	146	
	STUDS	Use SAE 2, 5 and 8 values when grade is known, with nut of sufficient strength.																			

SPECIFIC FASTENER TIGHTENING SPECIFICATIONS

The following is a list of torque specifications for specific components. The values given are in ft-lbs unless otherwise specified.

WHEELS	
Axle nuts	50
Sprocket mounting bolts or nuts	34 to 42
Brake disc mounting - 1978 16 in. wheel	21 to 27
1978 19 in. wheel	16 to 19
1974 to 1977	10
1972 and 1973	35
Wheel mounting bolts (drum brake)	50 to 55
BRAKES	
Rear brake anchor nuts	50
Caliper mounting bolts - FL front and rear	30 to 34
FX front 1978	115 to 120 in-lbs
1977 and earlier	30 to 34
FORKS	
Upper bracket pinch bolt	22 to 26
Lower bracket pinch bolts	22 to 26
Slider cap nuts	11
HANDLEBAR	
Throttle control clamp screws	12 to 16 in-lbs
Handlebar clamp screws	20
Riser mounting bolts - FL	40 to 45
FX	55 to 70

ENGINE

Sprocket shaft nut 1970 to 1971	170
1972 and later	400
Crank pin nuts	200
Pinion shaft nut	140 to 160
Pinion gear shaft nut	35 to 45
Oil pump cover bolt or nut	45 to 50 in-lbs
Cylinder head bolt	65
Cylinder base nut	32 to 36
Rocker arm cover nut	12 to 15
Upper engine mounting bracket nut	35 to 40
Stator mounting screw	30 to 40 in-lbs
Crankcase stud nut	12 to 15
Crankcase bolt	22 to 26
Tappet adjusting locknut	10

TRANSMISSION

Primary chain case bolts	18 to 22
Clutch hub nut	50 to 60
Starter cover nuts	13 to 16
Transmission sprocket locknut	140 to 150
Fork shaft nut	25
Shifter finger	50 to 60
Mainshaft ball bearing nut	6 to 9
Countershaft nut	55 to 65

ELECTRICAL

Timer plate screws	12 to 16 in-lbs
Cam bolt	20 to 24 in-lbs
Spark plugs	18 to 22 ft-lbs
Starter motor thru bolt	20 to 25 in-lbs

REGULAR SERVICE

The following chart outlines recommended Maintenance and Lubrication intervals after performance of service on a new motorcycle and the initial break-in period. Refer to Figure 1-1 when using the chart.

WARNING — For your personal welfare, all the listed service and maintenance recommendations should be followed, because they may affect the safe operation of your motorcycle.

IMPORTANT

To prevent over-greasing, use hand grease gun on all grease fittings.

REGULAR SERVICE INTERVALS CHART							
Regular Service Interval	Fig. 1-1 Index No.	Grease	Fig. 1-1 Index No.	Oil	Fig. 1-1 Index No.	Service	
Every 1000 miles	19	Rear brake pedal bearing	7	Rear chain (if chain oiler not used)	12	Air cleaner	
	9	Foot shift lever bearing	1	Clutch hand lever	11	Battery	
Every 2000 miles	26	Speedometer drive Foot clutch pedal bearing	14	Brake hand lever	27	Front and rear chain adjustment	
			3	Clutch control cable	17	Hydraulic brake fluid level	
			15	Front brake cable		Gasoline and oil valve, lines and fittings for leaks	
			13	Throttle control cable		Tighten nuts, bolts and fasteners	
			9	Shift control joints		Check wheel spokes, tire pressure and inspect tread	
			4	Seat post roller and bolt		Brake adjustment and lining wear	
			28	Seat suspension bushings		Clutch adjustment	
			4	Seat post		Oil filter	
			10	Seat bar bearing		Fuel strainer (if used)	
			23	Rear fork pivot bearing		Tappet oil screen	
Every 5000 miles or 1 year (whichever comes first)	13 18	Throttle control Circuit breaker cam and advance unit Speedometer and tachometer cables			8	Front chain adjustment	
					22	Rear chain oiler	
					18	Circuit breaker points and timing	
						Hydraulic brake fluid level	
					12	Check carburetor adjustment and idle speed	
					2	Inspect, clean and gap spark plugs	
						Tighten nuts, bolts and fasteners to specified torque	
						2	Replace spark plugs
						16,23	Time ignition
						6	Front and rear fork bearing adjustment
			24	Check shock rubber bushings			
			24	Change front fork oil			
			20	Check brake hydraulic fluid			
			20	Clean gas tank strainer screen and flush tank if dirty			

REGULAR SERVICE INTERVALS CHART (CONT)						
Regular Service Interval	Fig. 1-1 Index No.	Grease	Fig. 1-1 Index No.	Oil	Fig. 1-1 Index No.	Service
Every 10,000 miles	25	Repack wheel bearings and rear fork bearings every 10,000 miles or yearly if used for winter operation				
Weekly						Check tires Check battery

SERVICE INTERVAL ENGINE AND TRANSMISSION					
	300 Miles	1000 Miles	2000 Miles	5000 Miles or 1 Year	Spring and Fall
Engine Oil	Check	Check	Change		Change
Transmission Oil		Check		Change	Change

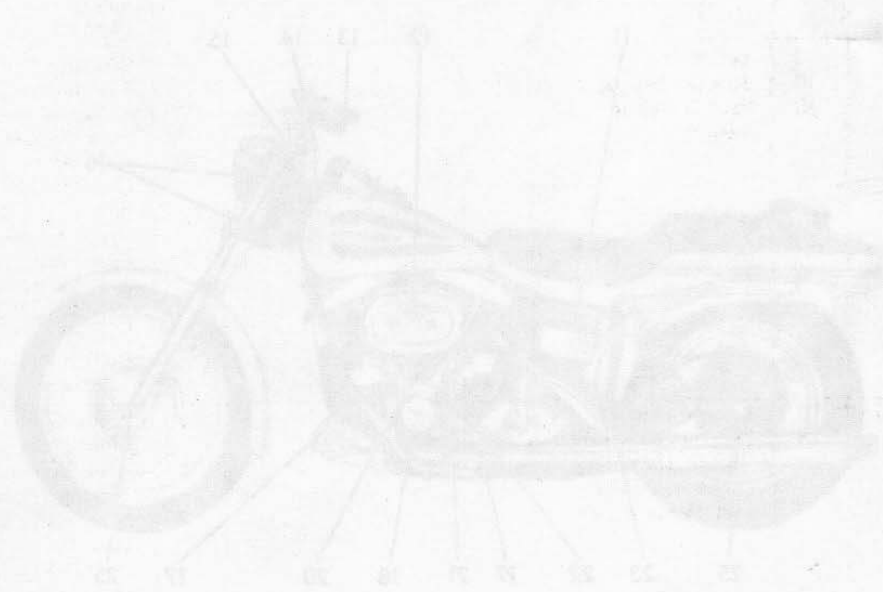

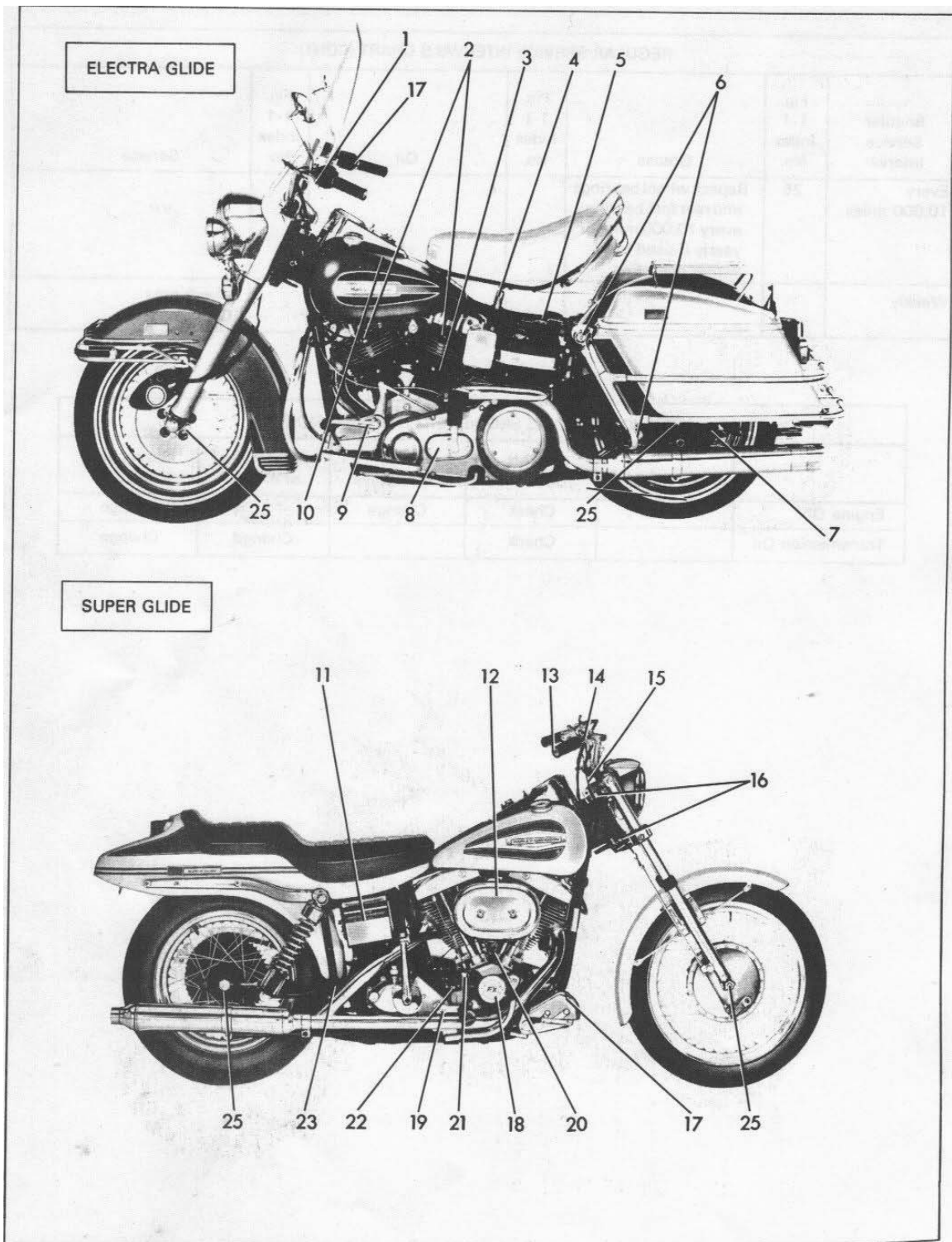
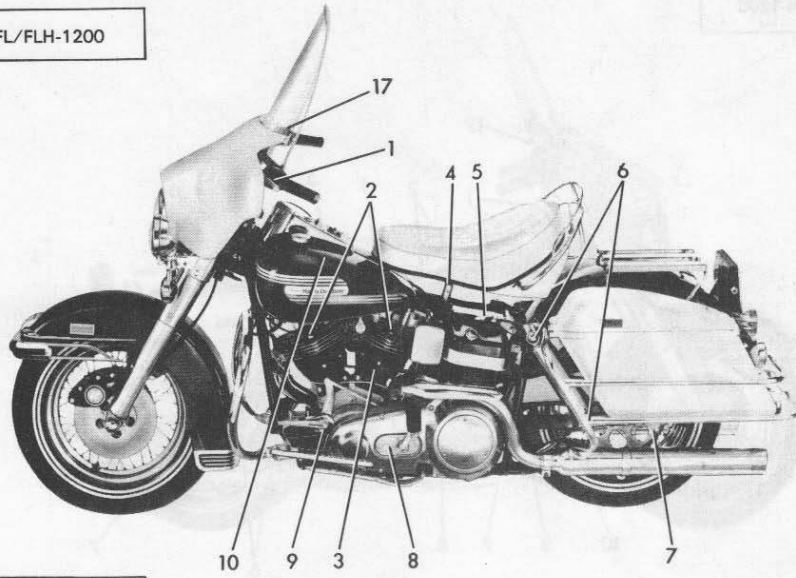

Figure 1-1. Lubrication and Service Chart - 1972

FL/FLH-1200



FX/FXE-1200

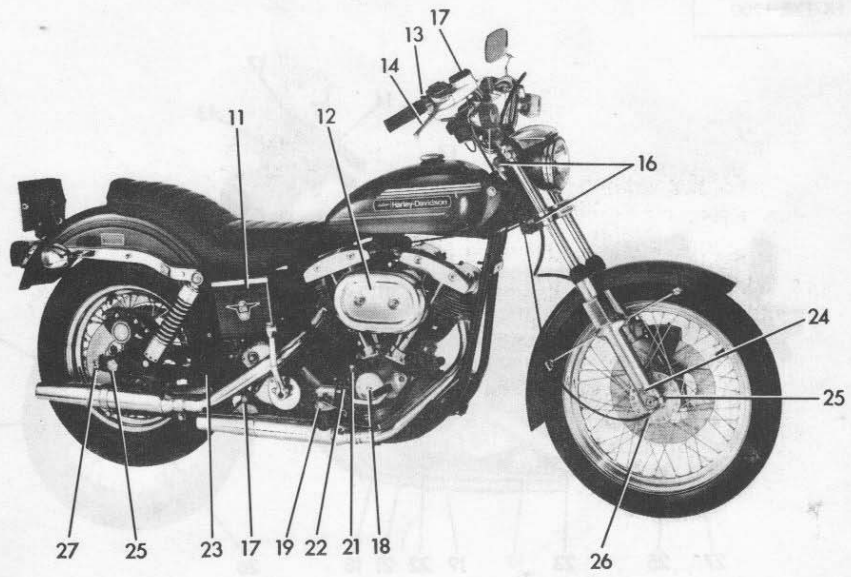

Figure 1-1A. Lubrication and Service Chart - 1974

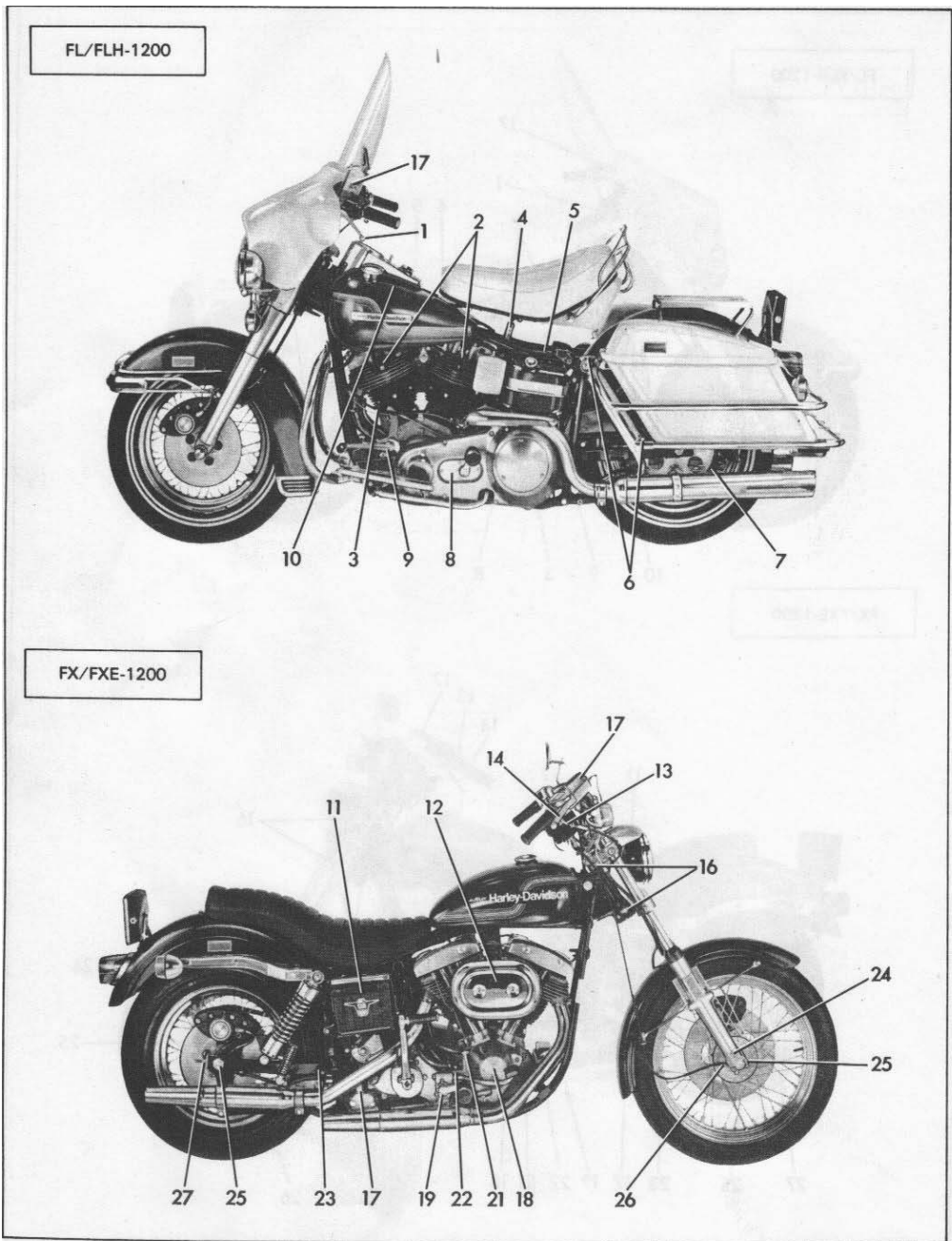
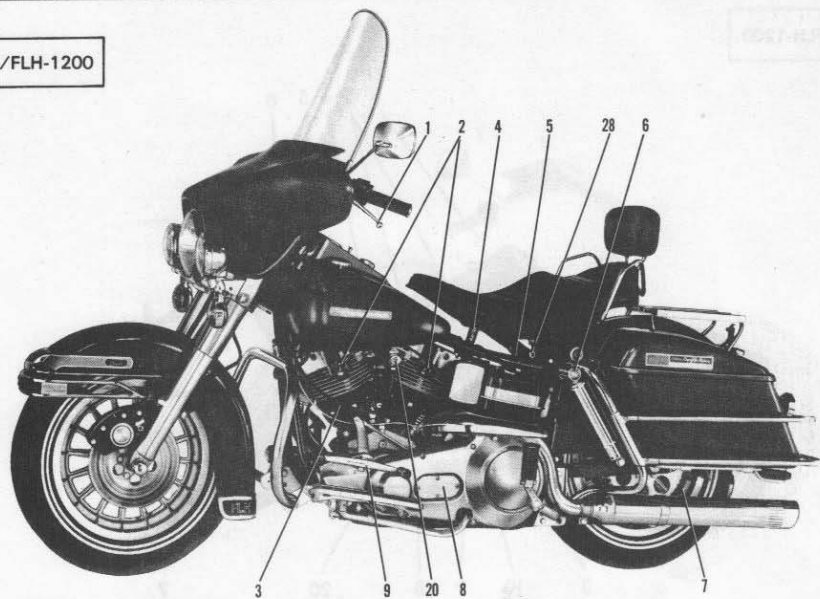

Figure 1-1B. Lubrication and Service Chart - 1975

FL/FLH-1200



FX/FXE-1200

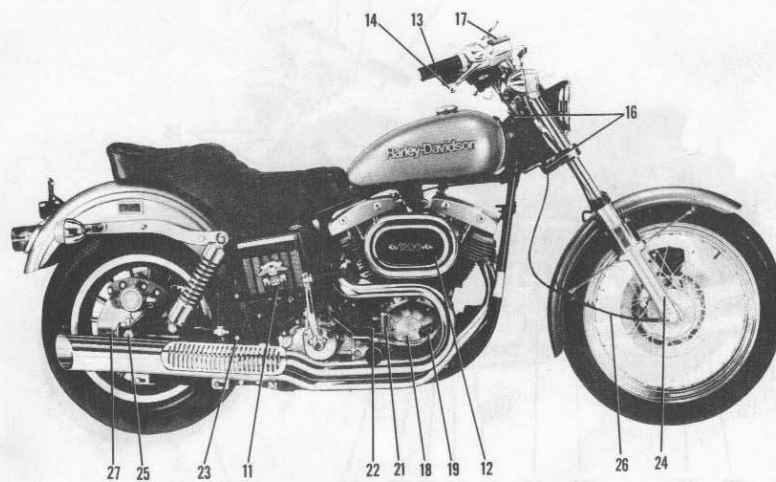

Figure 1-1D. Lubrication and Service Chart - 1977

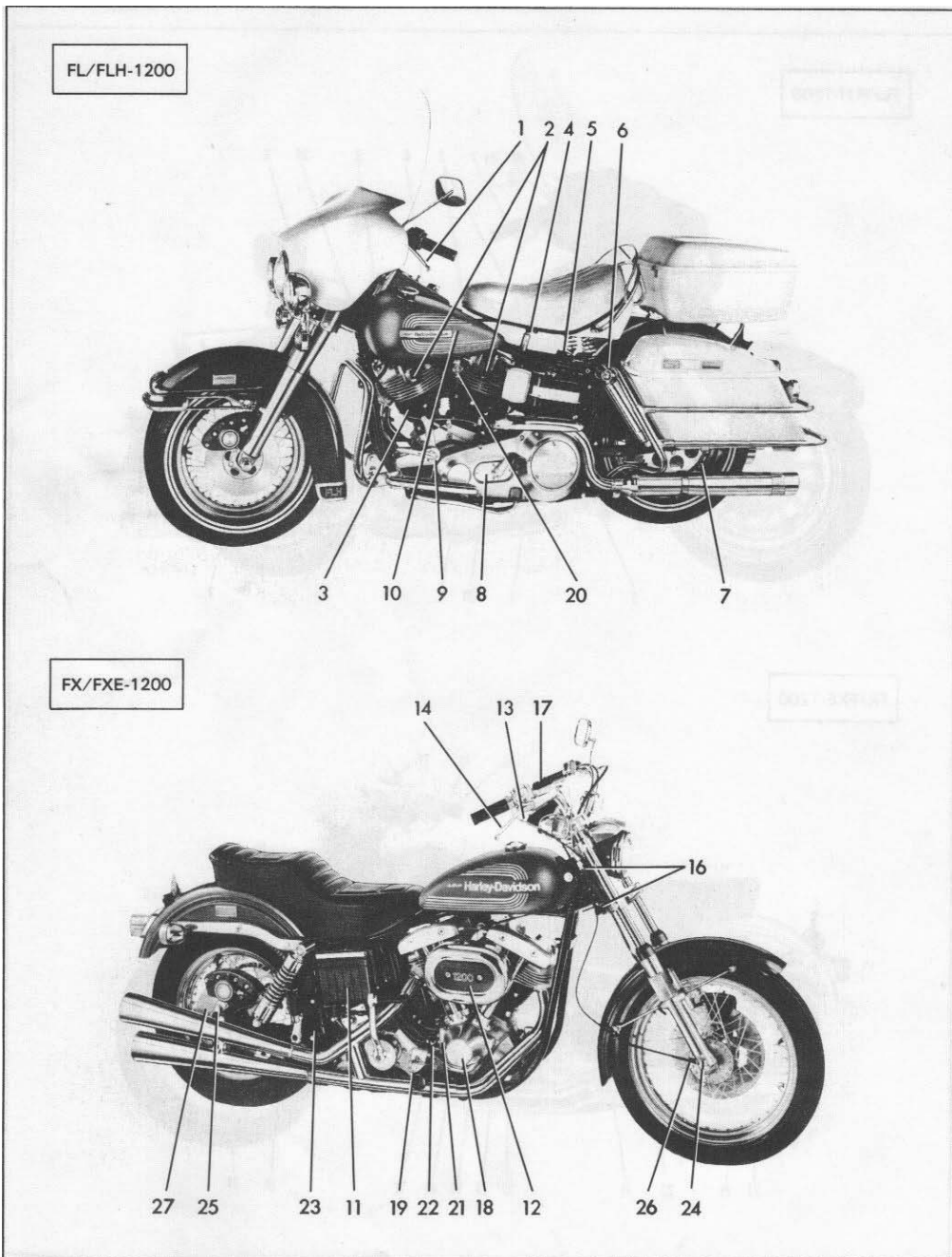
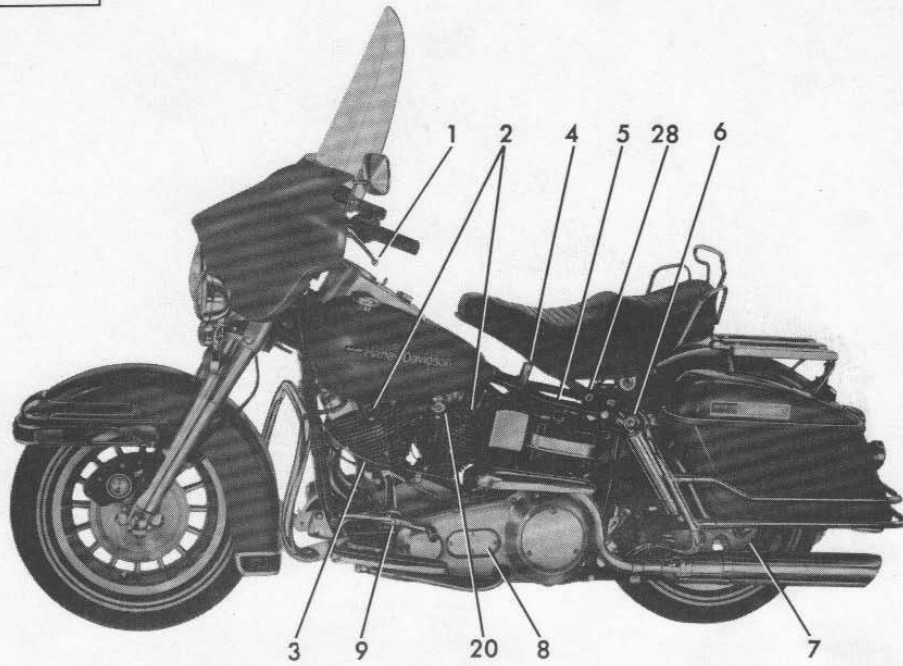

Figure 1-1C. Lubrication and Service Chart - 1976

FL/FLH-1200



FX/FXE/FXS-1200

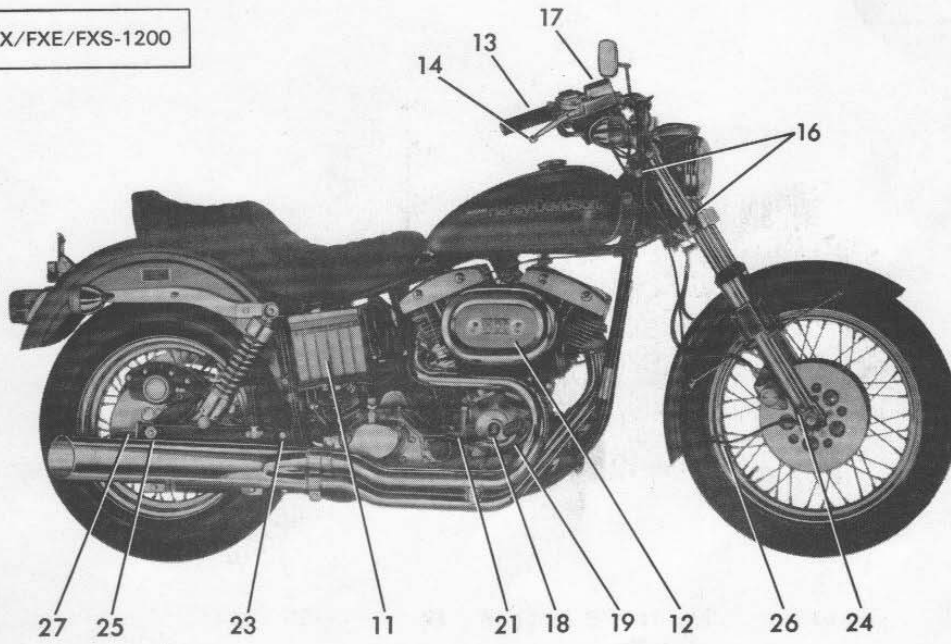

Figure 1-1E. Lubrication and Service Chart - Early 1978

FLUID REQUIREMENTS

LUBRICANTS TO USE

HARLEY-DAVIDSON OIL

Use proper grade of oil for the lowest temperature expected before next oil change period as follows:

Use Harley-Davidson Oil	Use Grade	Air Temperature (Cold Engine Starting Conditions)
Medium Heavy	75	Above 40°F
Special Light	58	Below 40°F
Regular Heavy	105	Severe operating conditions at air temperature above 90°F.

HARLEY-DAVIDSON GREASE-ALL GREASE

Use for all bearings on motorcycle, except where other special lubricants are recommended.

HARLEY-DAVIDSON CHAIN GREASE, CHAIN SAVER AND CHAIN SPRAY

Designed especially as a chain lubricant. Penetrates inner bearings for a long chain life.

GASOLINE

Use "Premium" grade leaded gasoline. Do not use "No-Lead" grades.

BRAKE FLUID

Use only D.O.T. 5 brake fluid.

HARLEY-DAVIDSON/LOCTITE PRODUCTS

The Harley-Davidson/Loctite products listed below are designed to increase the reliability of fasteners and to aid in minor repairs.

WARNING — Follow the directions listed on all Harley-Davidson/Loctite products. Read all labels, warnings and cautions carefully before using.

Application	Product	Part No.	Size
Lock fender braces, master cylinder bolts, brake anchors, exhaust flanges and general body hardware.	Lock N' Seal® Adhesive	99625-77	6 ml tube on card
Secure upper and lower fork assemblies, shock absorber mounts, fittings, axle nuts, shift lever screws, cylinder head and crankcase studs, and handle bar clamps.	Stud N' Bearing Mount Adhesive	99626-77	6 ml tube on card
Lock adjustment screws and assembled parts. Secure foot rests and kick starters.	Wick N' Lock™ Adhesive	99627-77	6 ml tube on card
Retain brake pedal bushings, main shaft sprockets, counter shafts, oil seals, drive train, linkage, clutch hub and sprocket assemblies.	Retaining Compound	99628-77	10 ml tube on card
Bond brake pedal and kick starter pads. Secure loose hand grips. Repair loose windshield moldings, and other rubber, vinyl and plastic parts.	SuperBonder® Adhesive	99629-77	3 ml tube on card
Seal threaded fuel line fittings, hydraulic brake line fittings and engine plugs.	Pipe Sealant with Teflon*	99630-77	6 ml tube on card
Make emergency gaskets on-the-spot. Seal crankcase covers, cylinder blocks to crankcase, fuel and oil pumps, and rocker arm covers.	Gasket Eliminator™ Sealant	99633-77	24 ml tube on card
Prevent galling, seizing and corrosion on oil drain plugs, spark plugs, front fork and shock assemblies and chain slides.	Anti-Seize Lubricant	99632-77	12 oz. aerosol can
Dissolve grease, dirt and oil from parts quickly and safely. Prepare mating surfaces for Loctite products.	Safety Solvent	99631-77	12 oz. aerosol can

*Reg. TM DuPont Corp.

LOCATING TROUBLES

The following check list will be helpful in locating most operating troubles. Refer to the appropriate sections in this service manual for detailed procedures.

ENGINE

CRANKING MOTOR DOES NOT OPERATE OR DOES NOT TURN ENGINE OVER

1. Engine run switch in "Off" position.
2. Ignition switch not on.
3. Discharged battery or loose or corroded connections. (Solenoid chatters.)
4. Starter control circuit, relay or solenoid defective.
5. Electric starter shaft pinion gear not engaging.

ENGINE TURNS OVER BUT DOES NOT START

1. Gas tank empty.
2. Gasoline valve turned off.
3. Gasoline line, valve or filter clogged.
4. Discharged battery or loose or broken battery terminal connections.
5. Fouled spark plugs.
6. Spark plug cables in bad condition and leaking or cable connections loose.
7. Badly oxidized circuit breaker points.
8. Circuit breaker points and/or ignition timing badly out of adjustment.
9. Loose wire connections at coil, at one of battery terminals or circuit breaker.
10. Defective ignition coil.
11. Defective condenser.
12. Sticking or damaged valve or tappets too tight.
13. Engine flooded with gasoline as a result of overchoking.
14. Engine and transmission oil too heavy (winter operation).
15. Overrunning clutch slipping.

STARTS HARD

1. Spark plugs in bad condition, have improper gap or are partially fouled.
2. Spark plug cables in bad condition and leaking.
3. Circuit breaker points in poor condition or out of adjustment.
4. Battery nearly discharged.
5. Loose wire connection at one of the battery terminals, at coil or circuit breaker.
6. Carburetor controls not adjusted correctly.

7. Defective ignition coil.
8. Defective condenser or condenser connection loose.
9. Engine and transmission oil too heavy (winter operation).
10. Circuit breaker cam sticking in advanced position.
11. Ignition not timed properly.
12. Gasoline tank cap bent or plugged, or carburetor fuel line closed off restricting fuel flow.
13. Water or dirt in fuel system and carburetor.
14. Choke disc stuck in open position.
15. Air leak in intake manifold.
16. Valves sticking.

STARTS BUT RUNS IRREGULARLY OR MISSES

1. Spark plugs in bad condition or partially fouled.
2. Spark plug cables in bad condition and leaking.
3. Spark plug gap too close or too wide.
4. Circuit breaker out of adjustment or in need of cleaning.
5. Condenser connections loose.
6. Defective ignition coil.
7. Defective condenser.
8. Battery nearly discharged.
9. Damaged wire or loose connection at one of battery terminals, or coil or circuit breaker.
10. Intermittent short circuit due to damaged wire insulation.
11. Water or dirt in fuel system and carburetor or filter.
12. Gasoline tank cap vent plugged or carburetor vent line closed off.
13. Carburetor controls misadjusted.
14. Weak or broken valve springs.
15. Air leak at intake manifold or air cleaner.
16. Damaged inlet or exhaust valve.
17. Incorrect valve timing.

A SPARK PLUG FOULS REPEATEDLY

1. Incorrect spark plug for the kind of service.
2. Piston rings badly worn or broken.
3. Fuel mixture too rich (see carburetor trouble chart).
4. Valve guides badly worn.

PRE-IGNITION OR DETONATION (Knocks or Pings)

1. Excessive carbon deposit on piston head or in combustion chamber.
2. Incorrect spark plug for the kind of service.

3. Defective spark plugs.
4. Ignition timing advanced.
5. Fuel octane rating too low.

OVERHEATING

1. Insufficient oil supply, or oil not circulating.
2. Leaking valves.
3. Heavy carbon deposit.
4. Carburetor adjustment too lean.
5. Ignition timing retarded.
6. Low power – circuit breaker cam sticking in retarded position.

VALVE TRAIN NOISE

1. Low oil pressure caused by oil feed pump not functioning properly or oil screen obstructed.
2. Hydraulic tappets not adjusted properly.
3. Defective hydraulic tappets.
4. Bent push rod.
5. Cam or cam gears worn.
6. Rocker arm binding on shaft.
7. Valve sticking in guide.

EXCESSIVE VIBRATION

1. Upper mounting bracket loose or broken.
2. Lower mounting bolts loose.
3. Broken frame.
4. Front chain badly worn or links tight as a result of insufficient lubrication.
5. Transmission and/or transmission sub-mounting plate loose in chassis.
6. Wheels and/or tires defective.
7. Internal engine problem.

LUBRICATION SYSTEM

OIL DOES NOT RETURN TO OIL TANK

1. Oil tank empty.
2. Scavenger pump gear key sheared.
3. Oil feed pump not functioning.
4. Restricted oil lines or fittings.

ENGINE USES TOO MUCH OIL OR SMOKES EXCESSIVELY

1. Breather valve incorrectly timed.
2. Piston rings badly worn or broken.
3. Chain oiler adjusting screw adjusted for an excessive amount of oil.

4. Insufficient chain case vacuum.
5. Valve guides worn.

ENGINE LEAKS OIL FROM CASES, PUSH RODS, HOSES, ETC.

1. Loose parts
2. Imperfect seal at gaskets, push rod cover, washers, etc.
3. Restricted oil return line to tank.
4. Restricted breather hose to air cleaner.

ELECTRICAL SYSTEM

ALTERNATOR DOES NOT CHARGE

1. Defective regulator-rectifier module.
2. Module not grounded.
3. Loose or broken wires in charging circuit.
4. Defective stator coils.
5. Defective rotor.

ALTERNATOR CHARGE RATE IS BELOW NORMAL

1. Defective regulator-rectifier module.
2. Defective stator coils.
3. Weak or defective battery.
4. Loose connections.

CARBURETOR

FLOODS

1. Inlet valve sticking.
2. Inlet valve and/or valve seat worn or damaged.
3. Dirt or other foreign matter between valve and its seat.
4. Excessive "pumping" of hand throttle grip.
5. Leaky or defective float.
6. Float misadjusted.

TRANSMISSION

SHIFTS HARD

1. Bend shifter rod.
2. Clutch dragging slightly.
3. Transmission oil too heavy (winter operation).
4. Shifter forks (inside transmission) sprung.
5. Corners worn off shifter clutch dogs (inside transmission).

JUMPS OUT OF GEAR

1. Shifter rod improperly adjusted.
2. Shifter forks (inside transmission) improperly adjusted.
3. Shifter engaging parts (inside transmission) badly worn and rounded.

CLUTCH

SLIPS

1. Clutch controls improperly adjusted.
2. Insufficient clutch spring tension.
3. Worn and/or soaked friction discs.

DRAGS OR DOES NOT RELEASE

1. Clutch controls improperly adjusted.
2. Clutch spring tension too tight.
3. Friction discs gummy.
4. Clutch shell keys or hub studs badly worn.
5. Clutch discs warped.

CHATTERS

1. Clutch hub friction disc rivets loose.
2. Clutch spring disc too flat.
3. Friction discs or steel discs worn or warped.

DRUM BRAKES

BRAKE DOES NOT HOLD NORMALLY

1. Master cylinder low on fluid.
2. Brake line contains air bubbles.

3. Master or wheel cylinder piston worn or parts defective.
4. Brake shoes improperly adjusted.
5. Brake controls binding.
6. Brake linings impregnated with grease as a result of over-lubrication.
7. Brake linings badly worn.
8. Brake drum disc badly worn or scored.
9. Brake shoes not centered.

DISC BRAKE

BRAKE DOES NOT HOLD NORMALLY

1. Master cylinder low on fluid.
2. Brake line contains air bubbles.
3. Master or wheel cylinder piston worn or parts defective.
4. Brake pads impregnated with grease or oil.
5. Brake pads badly worn (1/16 minimum lining thickness).
6. Brake disc badly worn or warped.
7. Brake fades due to heat build up – brake pads dragging or excessive braking.
8. Brake drags – insufficient brake pedal or hand lever free play.

TABLE OF CONTENTS

	PAGE
Drive	2-1
Wheels	2-5
Handlebar	2-19
Frame	2-21
Fork	2-23
Brakes	2-39
Seat	2-51
Fiberglass	2-55
Tools	2-61

DRIVE

CHAINS

GENERAL

Chain adjustment must be checked at regular intervals of 1000 miles for rear chain and 2000 miles for front chain. Rear chain requires more frequent attention than front, or primary chain. As chains stretch and wear, they run tighter at one spot than another. Always adjust free movement at tightest spot in chain to allow specified play midway between sprockets. Do not adjust tighter. Running chains too tight will result in excessive wear.

Inspect chains frequently for cracked, broken, or badly worn links. The rear chain may be taken apart for replacement or repair at the connecting, or master link. The front chain does not have a connecting link. It is necessary to remove the engine sprocket before the chain is removed for replacement. Repair of the front chain is not recommended. See "Stripping Motorcycle for Engine Repair," Section 3, for engine sprocket removal.

FRONT CHAIN ADJUSTMENT (Figure 2-1)

Remove rear pivot bolt from left footboard and swing rear end of footboard down, away from chain cover. Remove 8 cover attaching screws and remove cover. Front chain tension is adjusted by means of a shoe (1) which is raised or lowered underneath the chain to tighten or loosen it. The shoe support bracket (2) moves up or down in slotted backplate (3) after loosening center bolt (4) in backplate nut. Adjust shoe support as necessary to obtain specified up and

down free movement in upper strand of chain, midway between sprockets and retighten bolt securely.

Front chain adjustment:

5/8 to 7/8 in. chain slack with cold engine

3/8 to 5/8 in. chain slack with hot engine.

Shoe support bracket (2) and outer plate (5) have two sets of shoe attaching holes (A and B) so that entire assembly can be inverted to accommodate various sprocket sizes or chain lengths. To change over, remove center bolt (4), remove two shoe attaching capscrews (6) from set of holes (A), invert shoe and attach to alternate set of holes (B) with capscrews (6). Invert support bracket and outer plate and reattach with center bolt engaged in backplate nut.

REAR CHAIN ADJUSTMENT - 1972 AND EARLIER (Figure 2-2)

Remove the rear axle nut, lockwasher, and loosen brake sleeve nut (1) and brake anchor stud nut (4). Loosen the locknuts on wheel adjusting screws (2). Turn the adjusting screws as necessary to correctly adjust the chain. Turn each screw (3) an equal number of turns in order to keep wheel in alignment. Check correct alignment of the wheel to see that the tire runs in center of rear fork and also that the rear sprocket runs centrally in the chain. Specified rear chain play is 1/2 in. When readjustment is completed, be sure to securely tighten the sleeve nut, anchor stud nut, axle nut, and adjusting screw locknuts in that order.

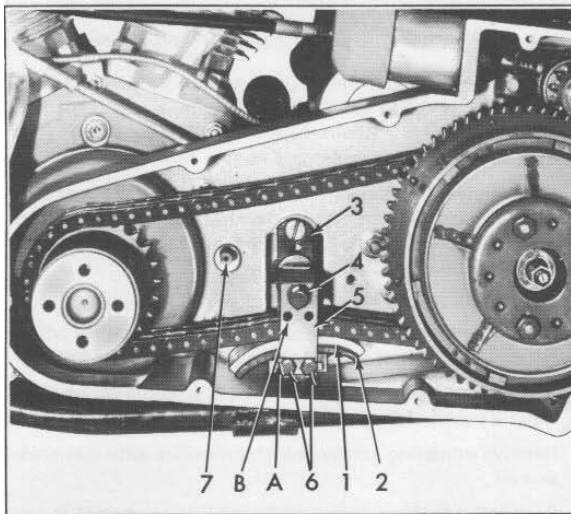

Figure 2-1. Adjusting Front Chain

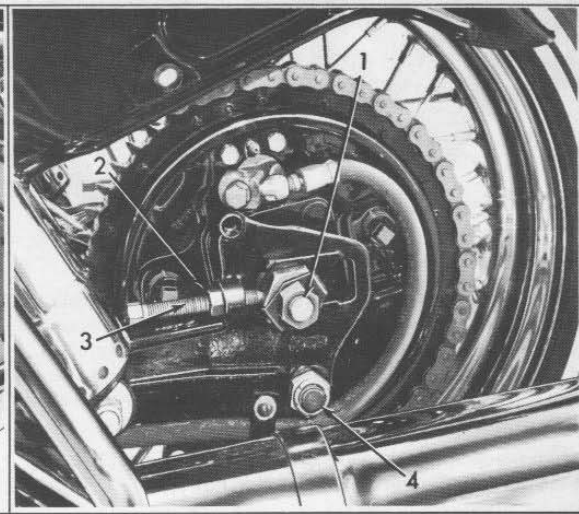
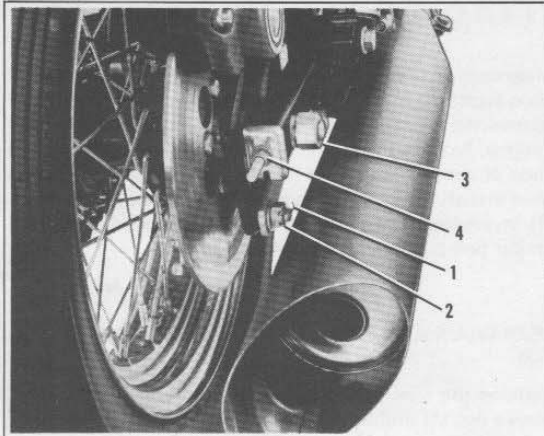

Figure 2-2. Adjusting Rear Chain (1972 and Earlier)

REAR CHAIN ADJUSTMENT - 1973 AND LATER (Figure 2-2A)

Remove cotter pin (1) and loosen brake anchor castle nut (2). Loosen axle nut (3). Turn adjusting nuts (4) as necessary to move axle and correctly readjust the chain. Turn each nut an equal number of turns in order to keep wheel in alignment. To move axle (5) forward it will be necessary to tap lightly on ends of studs.



- | | |
|---------------------|------------------------|
| 1. Cotter pin | 4. Axle adjusting nuts |
| 2. Brake anchor nut | 5. Rear axle |
| 3. Axle nut | 6. Rear chain |

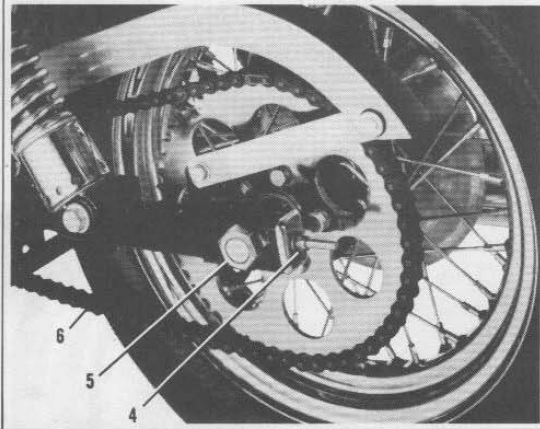

Figure 2-2A. Adjusting Rear Chain

A correctly adjusted rear chain should have 1/2 in. free play up and down movement half way between transmission sprocket and rear wheel sprocket. Check correct alignment of the wheel to see that the tire runs about midway between rear fork and also that the rear sprocket runs centrally in the chain.

When readjustment is completed, tighten axle nut (3) to 50 ft-lbs torque. Tighten brake anchor nut (1) to 50 ft-lbs torque. Install cotter pin (2).

FRONT CHAIN LUBRICATION

A fixed amount of oil is supplied through an oil line from metering orifice in the oil pump. Oil drops on front chain

from oiler outlet tube (7, Figure 2-1). Excess oil collects at rear of chain compartment and is drawn back into engine gearcase breather.

When the front chain adjustment is checked at 2000 mile intervals, also check to see that oil comes out of oiler tube when engine is running, when viewing through cover inspection hole. If oil does not come from oiler, the supply orifice at pump is probably blocked due to accumulation of dirt, and requires cleaning. To do this, remove orifice screw and washer from oil pump and blow out passage to chain compartment with compressed air.

REAR CHAIN LUBRICATION (Figure 2-3)

Motorcycle is equipped with a rear chain oiler. At regular 2000 mile intervals, make a close inspection of rear chain. If rear chain does not appear to be getting sufficient lubrication, or if there is evidence of an over-supply of oil, readjustment should be made with rear chain oiler adjusting screw. The rear chain oiler is located on the oil pump as shown below. Normally setting is 1/4 turn open which provides 2 or 3 drops per minute.

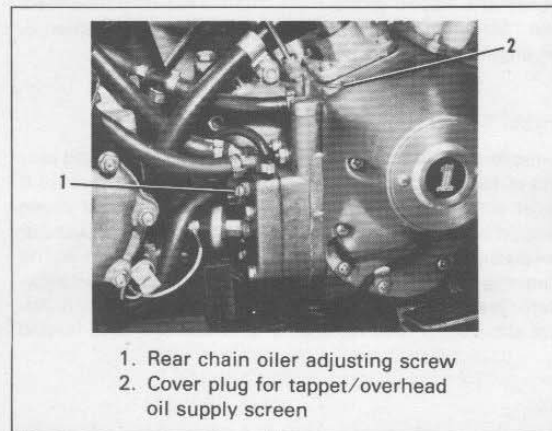

Figure 2-3. Rear Chain Oiler Adjustment

If chain oiler is not being used, brush dirt off chain and lubricate at 1000 mile intervals with Harley-Davidson "Chain Saver," "Chain Spray" or "Chain Grease" if available; if not available, use engine oil.

If the motorcycle is operated under extremely dusty or dirty conditions, thorough cleaning and lubrication of the rear chain may be advisable from time to time. Under these conditions, proceed as follows:

CLEANING CHAIN OILER

Normal setting of adjusting screw is 1/4 turn open. If orifice becomes blocked it will be necessary to clean as follows:

Turn adjusting screw inward until it bottoms on its seat. Keep a count of the number of turns.

Remove adjusting screw and clean orifice with compressed air.

Reinstall adjusting screw and turn it inward until it bottoms on its seat.

Turn adjusting screw outward the same number of turns determined in step 2.

LUBRICATION - UNUSUAL CONDITIONS

If motorcycle is operated under extremely dusty conditions, additional lubrication of the rear chain may be advisable from time to time. Under these conditions proceed as follows: remove chain from motorcycle. Soak and wash thoroughly in a pan of solvent such as kerosene. After removing chain from kerosene, allow kerosene to drain off or blow off with air hose. After chain is completely dry, apply Harley-Davidson chain spray, chain saver or chain grease following instructions or container label. Wipe all surplus lubricant from surface of chain. Install chain on motorcycle. Inspect connecting link and spring clip closely for bad condition. Replace if at all questionable. Be sure spring clip is correctly and securely locked on pin ends.

REMOVING AND INSTALLING REAR CHAIN

Locate and remove spring on connecting link. Free-fit connecting link used on early models can be removed by hand. Connecting link having press fit in side plate can be pressed apart with Chain Tool, Part No. 95020-38 which is supplied in accessory rider tool kit. A Shop Tool is available under Part No. 95021-29 for this purpose. To install new press fit connecting link, use Rear Chain Assembling Tool, Part No. 95020-66.

Be sure spring clip is securely locked on pin ends. Open end should be to the outside trailing direction of chain travel.

REPAIRING REAR CHAIN

To repair a chain, remove damaged link or links by pushing out pins with chain repair tool. Assemble new links and secure with connecting links.

GAUGING REAR CHAIN WEAR

When chain has been removed for cleaning, check it for elongation caused by wear as follows:

1. Lay chain on a flat surface.

2. Take up the play in the links by pushing the chain end toward each other, a few links at a time.

3. When the chain is fully compressed, measure its length. Stretch the chain to its full length and measure again. Replace rear chain if play exceeds 1 in.

GAUGING FRONT CHAIN WEAR

Front chain is not equipped with a connecting link so it cannot be opened for checking. Replace chain when you run out of shoe adjustment.

REMOVING AND INSTALLING FRONT CHAIN

Remove chain housing cover and lower front chain tensioner shoe as previously described under "Front Chain Adjustment." Then remove engine sprocket and clutch sprocket as described in "Disassembling Clutch," Section 4.

NOTE

Engine sprocket is aligned with clutch sprocket by a selection of spacers between sprocket and crankcase bearing. Reinstall same thickness of spacers as you removed, or determine correct spacer size as follows:

With clutch disassembled from clutch hub and compensating sprocket disassembled from sprocket shaft as shown, determine spacer (4, Figure 2-4) thickness as follows:

Example (refer to Figure 2-4):

1. Measure from chain cover surface to alternator rotor recess 1.750
2. Measure from chain cover surface to clutch disc friction surface 1.437
3. Subtract measurement (Step 2) from measurement (Step 1) (5/16 in.) .313
4. Spacer thickness from table120 in

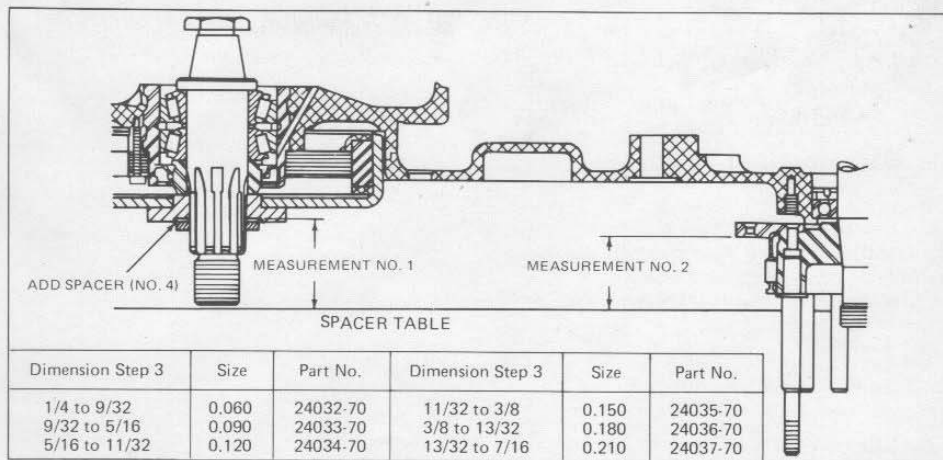

Figure 2-4: Determining Engine Sprocket Spacer Thickness to Secure Chain Alignment

WHEELS

GENERAL

Proper maintenance of the entire suspension system is necessary for safe handling and dependable motorcycle operation. Tire tread condition and inflation pressure are especially important among the many factors affecting handling given in the following check list.

CHECK LIST

At regular intervals of approximately 5000 miles or when a solo motorcycle develops handling irregularities at high speed, check the following list for possible causes:

1. Loose wheel axle nuts. Tighten to 50 ft-lbs maximum.
2. Excessive wheel hub bearing play.
3. Loosened spokes.
4. Rear wheel out of alignment with frame and front wheel.
5. Rims and tires out-of-true sideways (tire run-out should not be more than 3/64 in.).
6. Rims and tires out-of-round or eccentric with hub (tire run-out should not be more than 3/32 in.).
7. Irregular or peaked front tire tread wear. Replace tire if handling is affected.
8. Tires over-inflated. Check "Tire Data" Section. Do not over-inflate.
9. Tire and wheel unbalanced. Static balancing alone may be satisfactory if dynamic balancing facilities are not at hand, however both are recommended. See "Wheel and Tire Balancing."
10. Steering head bearings loose. Correct adjustment and replace pitted or worn bearings and races. See "Forks."
11. Shock absorber not functioning normally. Check possible causes. See "Forks."
12. Rear fork bearings loose. Check possible causes. See "Forks."
13. Heavy front end loading. Non-standard equipment on the front end such as heavy radio receivers, extra lighting equipment or luggage, tends to cause unstable handling. Extra equipment on the front end should be held down to a minimum.

In most every case, high speed handling faults are caused by one or more of the foregoing conditions being present on the motorcycle. The possible exception will be the case where there is serious frame or fork misalignment.

Keeping tires inflated to recommended pressure is of major importance. In many cases, this attention alone applied to a solo motorcycle will remedy faulty handling at high speeds.

It is advisable to rebalance wheels and tires, at least statically, whenever casing and/or tube is replaced.

FRONT WHEEL

FL - REMOVING AND INSTALLING

Block motorcycle under frame until front wheel is clear of ground. Disassemble in following order:

DRUM BRAKE MODELS (Figure 2-5)

Wheels may be removed as necessary for wheel or tire service. When removing a wheel, apply brake to hold drum securely while pulling wheel from drum. When detached from drums, Electra-Glide wheels are interchangeable.

Remove the cotter pin (1), axle nut (2) and flat washer (3). Remove the five wheel mounting socket screws (5). Loosen the two slider cap nuts (6) and remove axle (4). Remove front wheel, leaving the brake drum in its place over the brake shoes.

When replacing the wheel, assemble in reverse order. Important: Clamping faces on wheel hub and brake drum must be clean so that wheel will be true and tight against brake drum when socket screws are tightened. Securely tighten wheel mounting socket screws (5) to 35 ft-lbs torque. Tighten alternate screws so that brake drum is drawn evenly onto wheel. Tighten axle nut (2) to 50 ft-lbs torque, and then tighten the two slider cap nuts (6) to 11 ft-lbs torque. This will ensure correct alignment of fork sides.

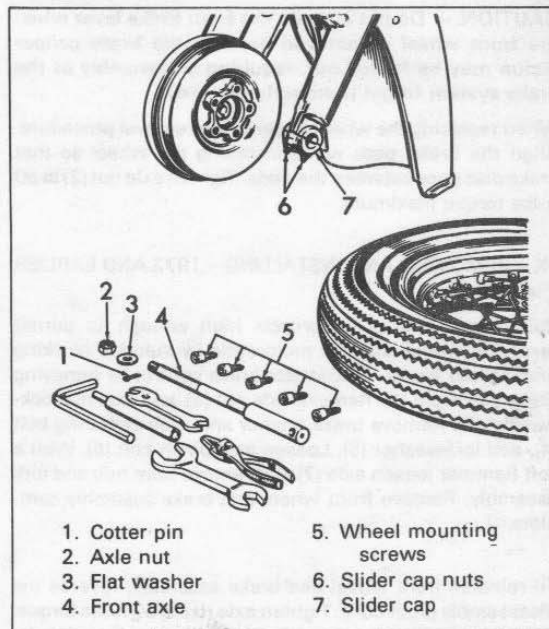
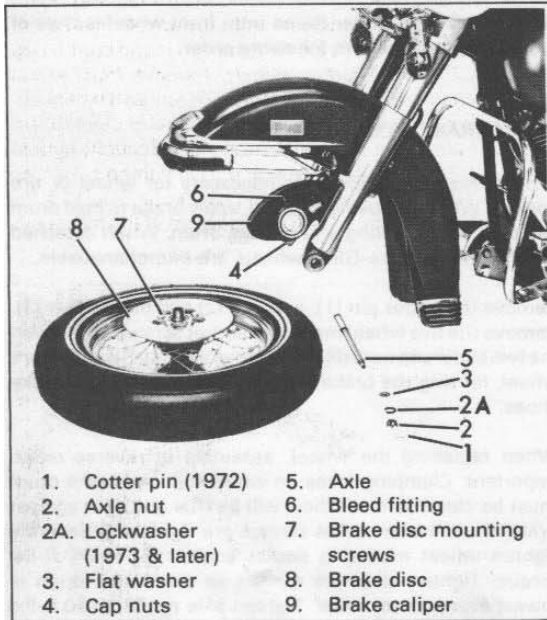

Figure 2-5. Front Wheel - FL (1971 and Earlier)

DISC BRAKE MODELS (Figure 2-6)

Remove the cotter pin (1) and castle nut (2) or nut (2) and lockwasher (2A). Remove flat washer (3). Loosen the two slider cap nuts (4) and remove axle (5). The front wheel is now free to come out.



- | | |
|-------------------------------|-------------------------------|
| 1. Cotter pin (1972) | 5. Axle |
| 2. Axle nut | 6. Bleed fitting |
| 2A. Lockwasher (1973 & later) | 7. Brake disc mounting screws |
| 3. Flat washer | 8. Brake disc |
| 4. Cap nuts | 9. Brake caliper |

Figure 2-6. Front Wheel - FL (1972 and Later)

CAUTION — Do not operate the front brake lever when the front wheel is removed because the brake caliper piston may be forced out, requiring disassembly of the brake system to get it properly resealed.

When replacing the wheel, reverse the removal procedure. Align the brake pads while installing the wheel so that brake disc goes between the pads. Tighten axle nut (2) to 50 ft-lbs torque maximum.

FX - REMOVING AND INSTALLING - 1972 AND EARLIER (Figure 2-7)

Raise front end of motorcycle high enough to permit removing wheel; support motorcycle by suitable blocking underneath frame. Disconnect brake control by removing brake clevis pin (1). Remove axle nut (2), and axle nut lockwasher (3). Remove brake anchor and shoe centering bolt (4), and lockwasher (5). Loosen axle pinch bolt (6). With a soft hammer loosen axle (7) and remove from hub and fork assembly. Remove front wheel and brake assembly complete.

To reinstall front wheel and brake assembly, reverse the disassembly procedure. Tighten axle nut to 50 ft-lbs torque. Center brake shoes as described in "Adjusting Front Wheel Brake." Inject one ounce of "Grease-All" grease into the wheel hub. Spin wheel, to make sure it turns freely.

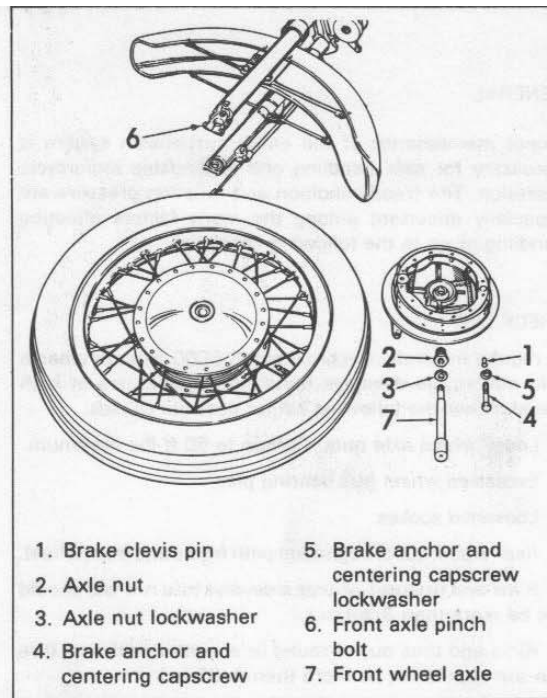

- | | |
|--|---|
| 1. Brake clevis pin | 5. Brake anchor and centering capscrew lockwasher |
| 2. Axle nut | 6. Front axle pinch bolt |
| 3. Axle nut lockwasher | 7. Front wheel axle |
| 4. Brake anchor and centering capscrew | |

Figure 2-7. Front Wheel - FX (1972 and Earlier)

FX - REMOVING AND INSTALLING - 1973 (Figure 2-8)

Support motorcycle underneath frame with front wheel raised. Remove axle nut (1) and axle nut lockwasher (2). Loosen slider cap nuts (3). With a soft hammer tap left end of axle (4) to loosen it and start it out. Pull axle (4) out of fork assembly. Remove front wheel assembly and speedometer drive. To reinstall, reverse above procedure. Align the brake pads while installing the wheel so that the brake disc goes between caliper (7) pads. Be sure speedometer drive (5) ear engages hole in wheel hub when installed. Securely tighten axle nut (1) (50 ft-lbs torque maximum) and then tighten the two slider cap nuts (3) to 11 ft-lbs torque. This will ensure correct alignment of the fork sides.

FX - REMOVING AND INSTALLING - 1974 TO 1977 (Figure 2-9)

Support motorcycle underneath frame with front wheel raised. Remove brake caliper mounting bolt (1), washers (2) and locknut (3). Remove axle nut (4), lockwasher (5) and washer (6). Loosen slider cap nuts (7). With a soft hammer tap left end of axle (8) to loosen it and start it out. Pull axle (8) out of fork assembly. Remove front wheel assembly and speedometer drive (9). To reinstall, reverse above procedure. Align the brake pads while installing the wheel so that the brake disc goes between caliper (10) pads. Be sure speedometer drive (9) ear engages hole in wheel hub when installed. Securely tighten axle nut (4) (50 ft-lbs) exercising care not to over-tighten, and then tighten the two slider cap nuts (7) to 11 ft-lbs torque. This will ensure correct alignment of the fork sides.

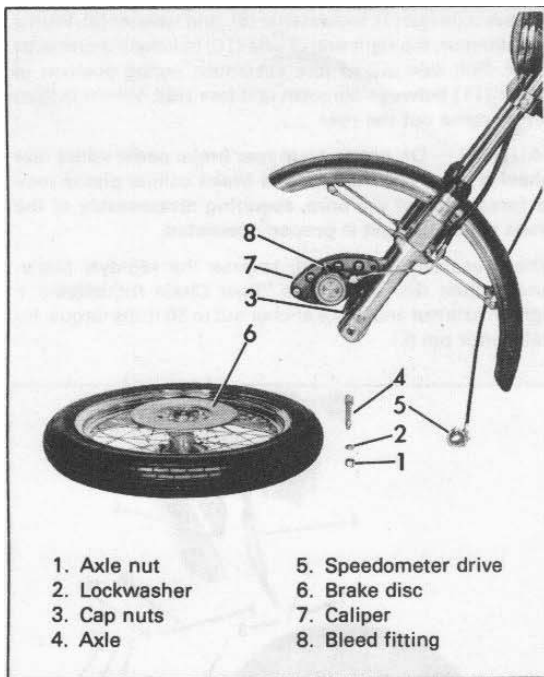

- | | |
|---------------|----------------------|
| 1. Axle nut | 5. Speedometer drive |
| 2. Lockwasher | 6. Brake disc |
| 3. Cap nuts | 7. Caliper |
| 4. Axle | 8. Bleed fitting |

Figure 2-8. Front Wheel - FX (1973)



- | | |
|--------------------------|-------------------------|
| 1. Caliper mounting bolt | 7. Axle slider cap nuts |
| 2. Washer (2) | 8. Axle |
| 3. Locknut | 9. Speedometer drive |
| 4. Axle nut | 10. Caliper |
| 5. Axle lockwasher | 11. Brake disc |
| 6. Axle washer | 12. Bleeder fitting |

Figure 2-9. Front Wheel - FX (1974 to 1977)

FX - REMOVING AND INSTALLING - 1978 (Figure 2-10)

Support motorcycle underneath frame with front wheel raised. Detach both the right and left caliper mounting hardware (3). Let caliper assemblies hang down loose out of the way as shown in figure. Remove axle nut (6), lockwasher (7) and washer (8). Loosen slider cap hardware (4). With a soft hammer tap left end of axle (5) to loosen it and start it out. Pull axle (5) out of fork assembly. Remove front wheel assembly and speedometer drive (9). To reinstall wheel, reverse above procedure. Be sure speedometer drive (9) ear engages hole in wheel hub when installed. Securely tighten axle nut (6) to 50 ft-lbs torque and then tighten slider cap hardware (4) and caliper mounting hardware (3) to 11 ft-lbs torque. This will ensure correct alignment of the fork sides.



- | | |
|---------------------------------------|----------------------|
| 1. Left side caliper | 5. Axle |
| 2. Right side caliper | 6. Axle nut |
| 3. Caliper mounting hardware (2 sets) | 7. Lockwasher |
| 4. Slider cap hardware (2 sets) | 8. Washer |
| | 9. Speedometer drive |
| | 10. Brake discs |

Figure 2-10. Front Wheel - FX (1978)

REAR WHEEL

REMOVING AND INSTALLING - 1972 AND EARLIER (Figure 2-11)

Elevate motorcycle rear end with service stand, or suitable blocking under frame so rear wheel is off the ground. Remove two rear screws from fender support, and raise end of fender. Remove the five socket screws (4) that secure wheel to brake drum. The socket screw wrench can be inserted only at the rear of axle; turn wheel to bring each screw to this position.

Remove axle nut (3) and axle nut lockwasher (2). Remove axle (1) from brake drum side of motorcycle and then remove spacer (5) from between wheel hub and right axle clip. Apply rear brake and remove wheel.

NOTE

Foot Brake Lever Locking Tool, Part No. 95875-58, can be used to lock brake. To use tool, raise right side foot board, slip tool over brake lever stop pin, depress brake pedal and rotate tool so that cam on tool end locks brake pedal in depressed position.

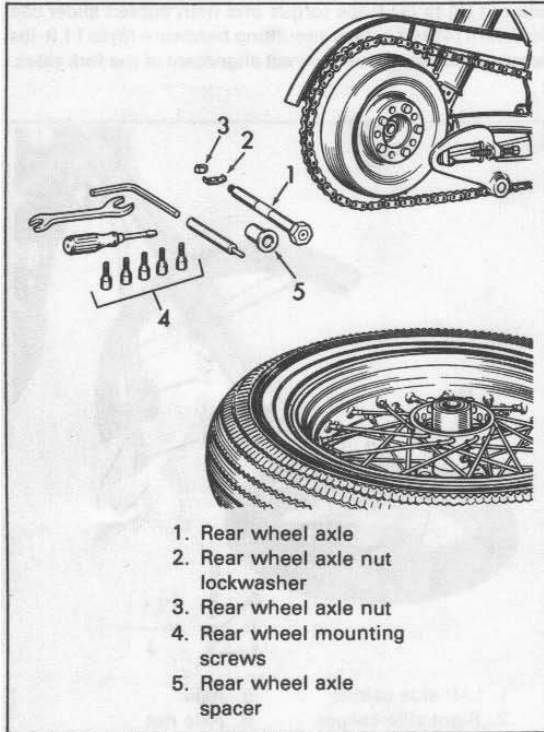

Figure 2-11. Removing Rear Wheel (1972 and Earlier)

When installing wheel, reverse the removal procedure. Important: Clamping faces on drum and wheel hub must be clean so that wheel will be true and tight against brake drum when socket screws are tightened. Securely tighten the five wheel socket screws to 35 ft-lbs torque before tightening the axle nut (3) to 50 ft-lbs. To avoid possibility of wheel working loose and damaging clamping flange, it is important that socket screws be tightened as specified.

REMOVING AND INSTALLING - 1973 AND LATER
(Figure 2-12)

Support rear end of motorcycle with rear wheel off the ground. Disconnect rear chain at connecting link (3) by removing spring clip (1) and side plate (2). Remove brake anchor nut cotter pin (5) and loosen castle nut (6).

Remove axle nut (7), lockwasher (8), and washer (9). With a soft hammer, tap right end of axle (10) to loosen it and start it out. Pull axle out of fork assembly, noting position of spacer (11) between sprocket and fork side. Wheel is then free to come out the rear.

CAUTION — Do not operate rear brake pedal when rear wheel is removed because the brake caliper piston may be forced out of the bore, requiring disassembly of the brake system to get it properly resealed.

When reassembling wheel, reverse the removal procedure. Adjust rear chain (see "Rear Chain Adjustment"). Tighten axle nut and brake anchor nut to 50 ft-lbs torque. Install cotter pin (5).



Figure 2-12. Removing Rear Wheel (1973 and Later)

SIDECAR WHEEL

REMOVING AND INSTALLING

Raise wheel by blocking up under sidecar chassis. Loosen the fender inner brace bracket nut. Remove outside axle nut, lockwasher and outer brace. Hinge fender forward, taking care to provide slack for tail lamp wiring. Remove extension nut, axle nut and washer. Pull wheel from axle with brake drum attached.

Detachment of wheel from brake drum is necessary only when wheel or brake drum is to be replaced or wheel interchanged. To detach wheel from brake drum, remove the five wheel mounting socket screws that secure wheel to brake drum.

To replace wheel, reverse removal procedure. Tighten wheel mounting socket screws to 35 ft-lbs torque to avoid possibility of wheel working loose and damaging hub flange.

WHEEL HUB AND BRAKE DRUM OR DISC

GENERAL

1972 and earlier front and rear wheels have permanently lubricated and sealed, retainer type ball bearings. FL front and rear wheels are identical and interchangeable when detached from brake drums or brake disc flange. Bearings require no interval attention.

1973 and later front and rear wheels have tapered roller bearings which should be repacked every 10,000 miles or yearly if operated in winter weather. Use Harley-Davidson Grease-All grease and new seals. FL front and rear wheels are identical and interchangeable when detached from brake discs and sprocket. Excessive looseness or roughness in the bearings when wheel is turned indicates worn bearings, and they must be replaced.

DISASSEMBLING AND ASSEMBLING 16 INCH WHEEL HUB - 1972 AND EARLIER (Figure 2-13)

Remove 5 wheel mounting socket screws (1) and remove brake drum (2) or brake disc flange (2A) from wheel hub (9). Remove bearing spacer (3) from wheel hub. Press bearing parts (8) or (8, 8A and 8B) out of brake drum with suitable plug from wheel hub side. On late 1970 and later models, remove retainer screws (10) and retainer (11). Wheel hub ball bearing locknut (4) has a left hand thread. Using tool, Part No. 94630-67 engage slot and turn to right to remove nut from hub. Remove seal (5), and spacer (6) from wheel hub. Press bearing (7) out of wheel hub with suitable plug from brake drum side.

Turn bearings by hand to check for roughness and check also for excessive looseness of the inner and outer race. Inspect seal lip for wear or damaged rubber. Replace defective parts.

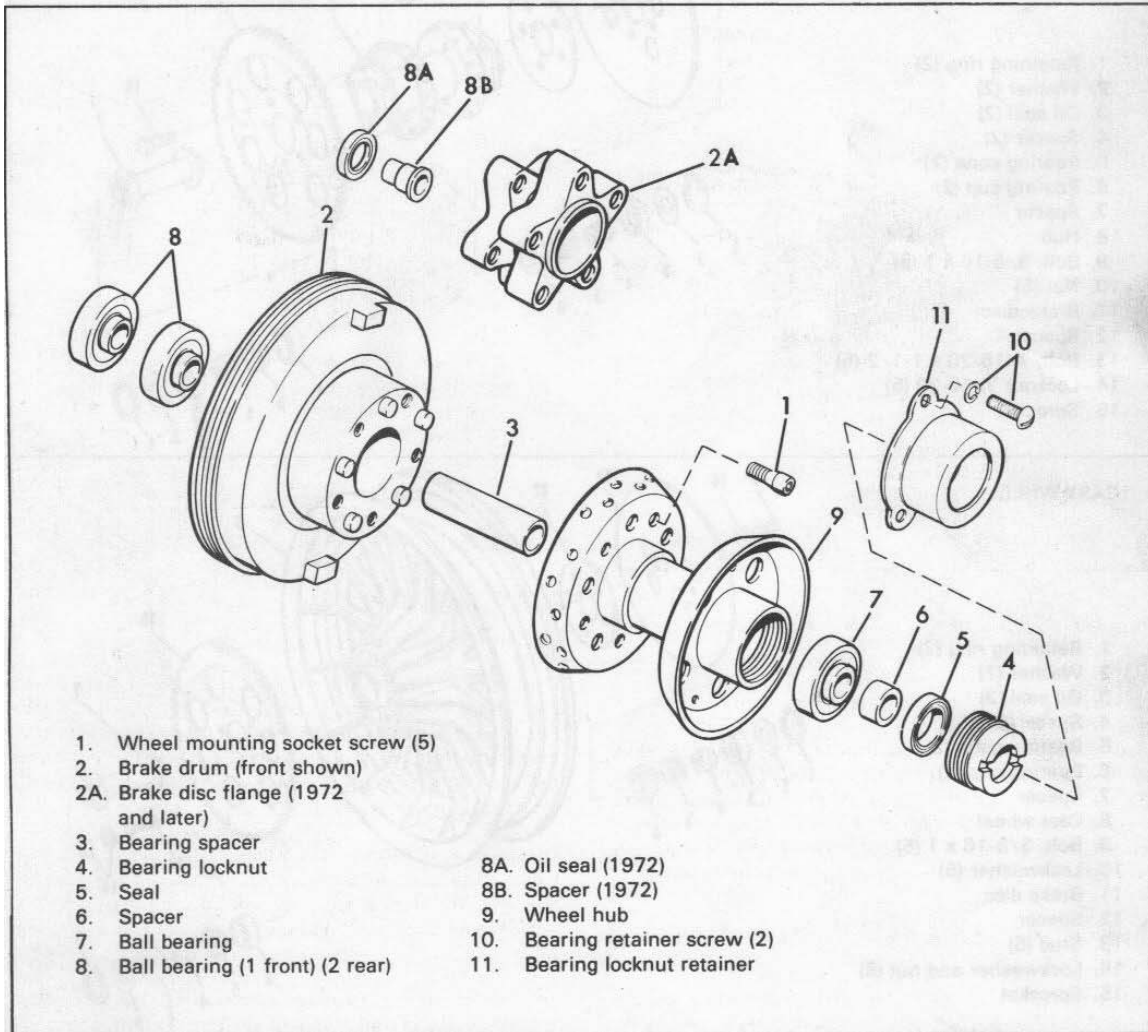

Figure 2-13. FL Wheel Hub - Front and Rear Wheel (1972 and Earlier)

Assemble hub and brake drum or brake disc flange components in reverse order of disassembly.

When assembling bearings, apply a liberal quantity of grease to fill space on both sides of bearing in wheel hub and on inside bearing of brake drum.

IMPORTANT

Tighten wheel bearing locknut (4) with tool, Part No. 94630-67. Turn to left and tighten securely by striking wrench handle with a mallet. After nut is tightened, stake hub in 4 places with a centerpunch at threads so that locknut cannot loosen and back out. Late 1970 and later models with wheel hub locknut retainer (11)

do not require hub staking. Instead, drive retainer into nut (4) slots with a chisel point to lock nut in place.

Clamping faces on drum and wheel hub must be clean so that wheel will be true and tight against brake drum or brake disc flange when socket screws are tightened. Tighten alternate screws to 35 ft-lbs torque so that brake drum or brake disc flange is drawn down evenly onto wheel.

DISASSEMBLING AND ASSEMBLING 16 INCH WHEEL HUBS - 1973 AND LATER (Figure 2-14)

Remove 2 retaining rings (1), washers (2), oil seals (3), spacers (4), and bearing cones (5).

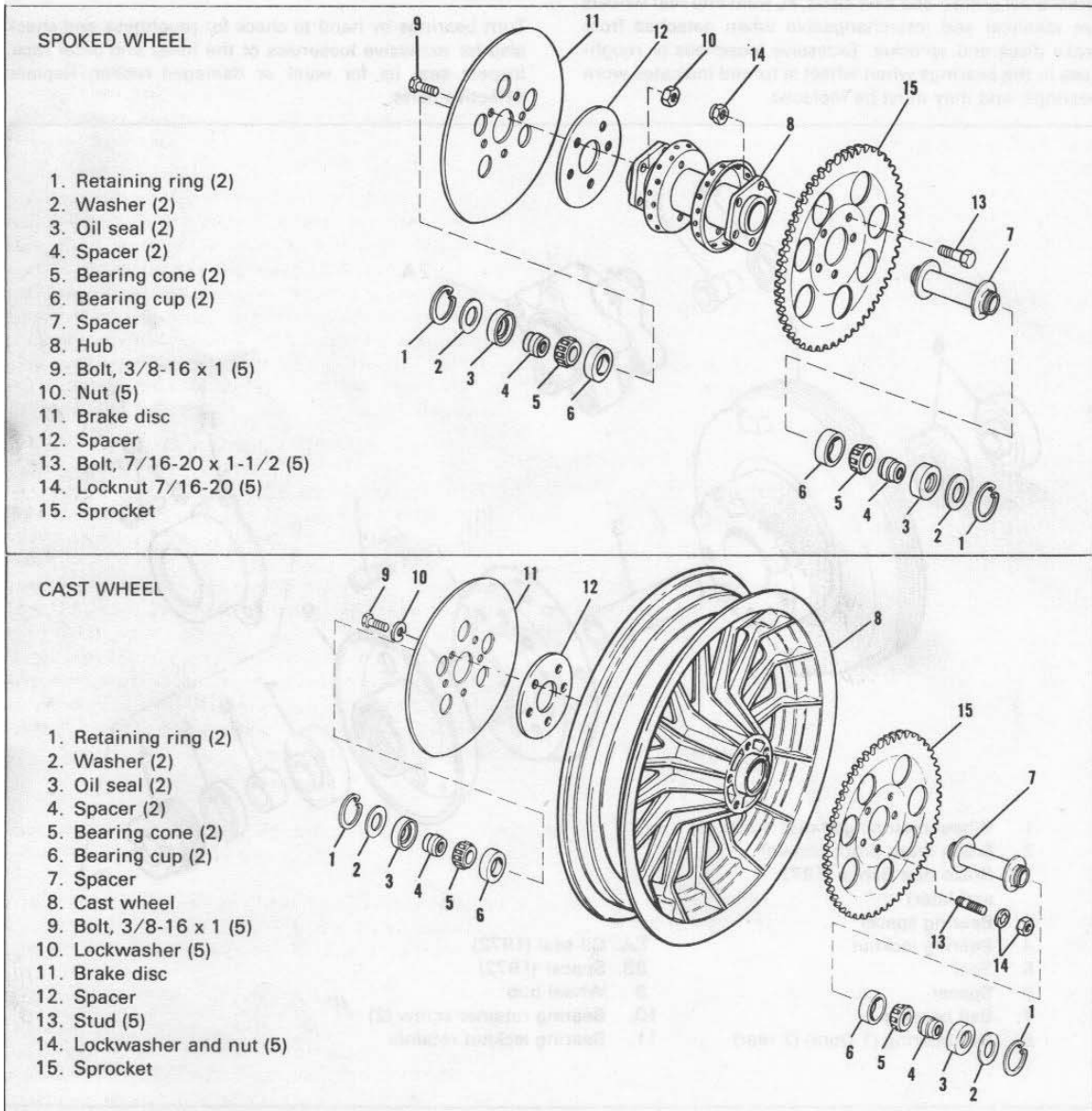

Figure 2-14. 16 Inch Wheel Hub (1973 and Later) - Exploded View

Clean all parts in solvent and inspect for damage or wear. Replace parts as necessary. If bearing cones or cups need replacing, replace as a set. Use a standard bearing puller to remove bearing cups (6) from hub (8). Inspect brake discs for warping, scoring or worn running surfaces. Replace as necessary. On spoked wheels, check spoke flanges for bent or damaged condition.

Reassembly is basically the reverse of disassembly with the following exceptions: Apply a liberal amount of Harley-Davidson Grease-All grease to bearing cones before assembly. Lubricate lip of oil seal (3) before assembly. Press oil seal (4) into hub until it is 3/16 to 1/4 in. below outside edge of hub. Bearing end play should be 0.004 to 0.018 in. when axle nut is tightened to 50 ft-lbs torque. If end play is not correct, substitute a slightly longer or shorter spacer (7) as necessary.

If brake disc (11), spacer (12) and sprocket (15) have been disassembled, make sure all mounting surfaces are clean and flat before reassembly. Tighten sprocket mounting nuts or bolts to 34 to 42 ft-lbs torque. Tighten brake disc mounting bolts to 21 to 27 ft-lbs torque.

FX - DISASSEMBLING AND ASSEMBLING 19 INCH WHEEL HUB - 1972 AND EARLIER (Figure 2-15)

Pry grease seal (1) from wheel hub. Remove retaining ring (2) with Tru-arc lock ring pliers. Tap ball bearing (3) inward all the way against its seat in hub. This will move bearing (4) out far enough so that spacer (5) can be moved away from bearing (4). Then use a drift to tap out bearing (4) from opposite end of hub. Bearing (3) can now be tapped out from opposite end.

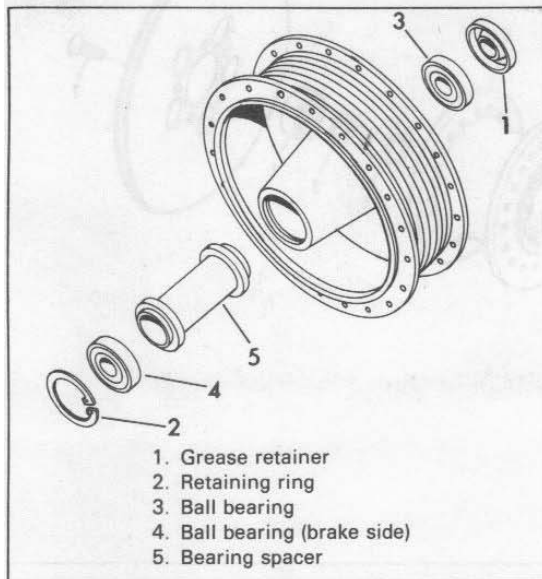

Figure 2-15. Front Wheel Hub - FX (1972 and Earlier)

Clean and pack both ball bearings with fresh Grease-All Grease. Press brake side ball bearing (4) against shoulder in hub, shielded side out. Install retaining ring (2) using Tru-arc lock ring pliers.

IMPORTANT

Flat side of retaining ring must be toward the bearing.

Install bearing spacer (5). Press ball bearing (3) against shoulder in hub and tap grease retainer (1) in place.

FX - DISASSEMBLING AND ASSEMBLING 19 INCH WHEEL HUBS 1978 (Figures 2-17, 2-17A)

Remove oil seals (1), spacer (2), and bearing cones (3). Use a bearing puller to remove bearing cups (4). Spacer (5) may now be removed. Brake disc (6 or 6A) is secured to hub (9 or 9A) with 5 bolts and lockwashers (8) or screws (8A).

Clean and inspect all parts, paying particular attention to the wheel hub bearings. If bearings have excessive side play or radial (up and down) play in the wheel hubs, they should be replaced. If ball bearings have been removed from the hubs, carefully examine for visible wear, heat discoloration or damage to inner and outer races. Inspect brake shells or brake disc for scoring, grooving and worn running surfaces. Check spoke flanges for bent or damaged condition. Recommended hub repair is replacement of worn or damaged parts.

Reassembly is basically the reverse of disassembly with the following exceptions: Apply a liberal amount of Harley-Davidson Grease-All to bearing cones (4) before assembly. Press oil seals (1) into hub flush with outer surface. Lubricate lip of oil seal before inserting spacer (2). If brake disc (6 or 6A) and brake disc spacer (7) have been disassembled make sure all mating surfaces are clean and flat before assembly. Apply Harley-Davidson "Stud and Bearing Mount," Part No. 99626-77 to threads and tighten bolts (8) to 35 ft-lbs torque or screws (8A) to 10 ft-lbs torque. When wheel is assembled to motorcycle, bearing end play should be .004 to .018 inch with axle nut tightened to 50 ft-lbs torque. If end play is not correct, substitute a slightly longer or shorter spacer (5) as necessary.

FX - DISASSEMBLING AND ASSEMBLING 19 INCH WHEEL HUBS 1978 (Figures 2-17, 2-17A)

Remove oil seals (1), spacer (2) and bearing cones (3). Use a standard bearing puller to remove bearing cups (4). Spacer (5) may now be removed. Brake discs (6) are secured to hub (8) with screws (7).

Clean all parts in solvent and inspect for damage or wear. Replace parts as necessary. If bearing cones or cups need replacing, replace as a set. Inspect brake discs for warping, scoring or worn running surfaces. Replace as necessary. On spoked wheels, check spoke flanges for bent or damaged condition.

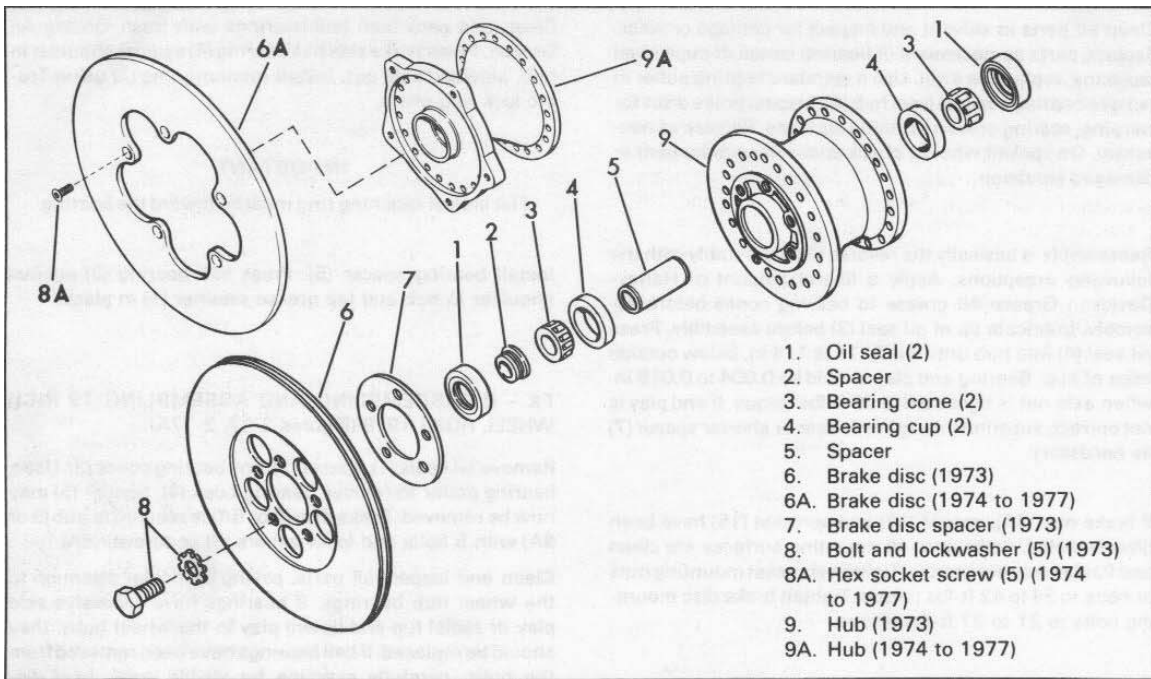

Figure 2-16. FX - Front Wheel Hub - Exploded View (1973 to 1977)

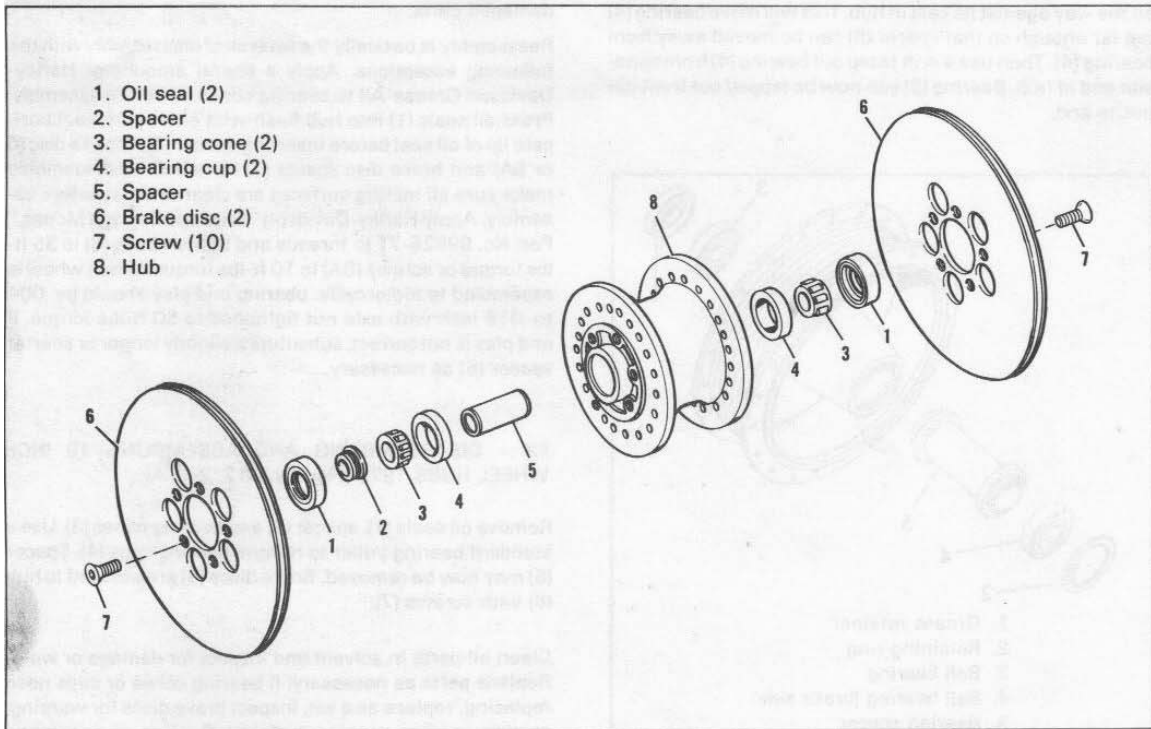

Figure 2-17. 19 Inch Spoked Wheel - FX Front (1978)

Reassembly is basically the reverse of disassembly with the following exceptions; Apply a liberal amount of Harley-Davidson Grease-All grease to bearing cones before assembly. Lubricate lip of oil seal (1) before assembly. Press oil seals (1) into hub flush with outer surface. If brake discs (6) have been disassembled, make sure all mating surfaces are clean and flat. Apply Harley-Davidson "Stud and Bearing Mount," Part No. 99626-77, to threads of screws (7) and tighten to 16 ft-lbs torque. When wheel is mounted to motorcycle and axle nut is tightened to 50 ft-lbs torque, bearing end play should be 0.004 to 0.018 in. If end play is not correct, substitute a slightly longer or shorter spacer (5) as necessary.

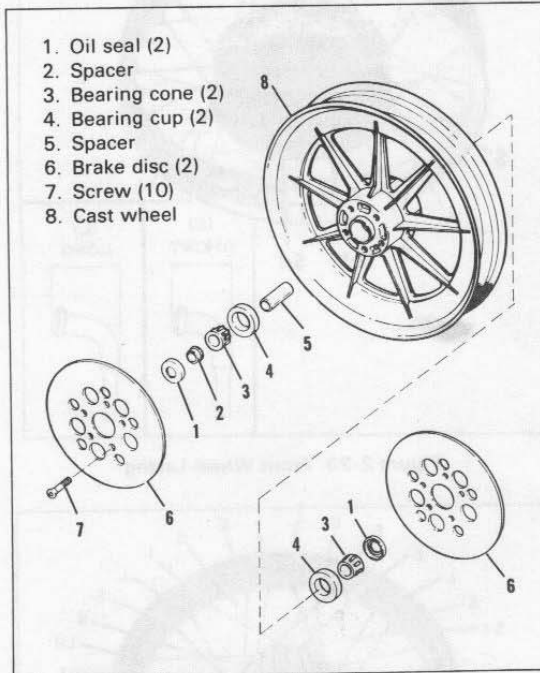

Figure 2-17A. 19 Inch Cast Wheel - FX Front (1978), FXS Front (Early 1977 and Later)

REAR WHEEL SPROCKET

REPLACING REAR WHEEL SPROCKET - 1972 AND EARLIER

To replace a worn rear wheel sprocket remove wheel from motorcycle as described in "Rear Wheel, Removal." Remove brake drum and place in a vise. Chisel heads off all rivets and dowel pins from brake shell side and punch them out. If the rivet holes are not worn, use the rivet holes again. If the rivet holes are found slightly worn or elongated and drum is in good condition, drill a new set of rivet holes in drum flange midway between original dowel and rivet holes.

To drill new rivet holes, proceed as follows using new sprocket as a template for locating holes.

1. Drill a 0.1935 in. (No. 10 drill) hole for a 3/16 in. rivet from the brake shell side.

2. Drill one hole and insert rivet (do not head rivet).
3. Drill a hole directly opposite first hole and insert rivet (do not head rivet).
4. Drill remaining 14 rivet holes.
5. Remove rivets and separate sprocket from drum.
6. Remove burrs from newly drilled holes.

Whenever a rear wheel sprocket is replaced it is very important to drill new dowel holes to ensure a press fit for the dowel pins. Use the new sprocket as a template and drill the four dowel pin holes 3/16 in. dia. for a press fit.

Position sprocket and drum on center support flange of Riveting Jig, Part No. 95600-33B. Proceed as follows, insert and seat dowel pins first, and then rivets.

1. Insert dowel pins and rivets from brake shell side.
2. Use hollow driver and seat dowel pins and rivets at the same time driving sprocket and hub flange together.
3. Use punch to flare dowel pin ends and rivet ends until heads extend 3/32 in. above sprocket face. Use concave end punch for small diameter rivets and dowel pins. Use flat end punch for larger diameter rivets.
4. Rivet opposite dowel pins and rivets until all are in place.

REPLACING REAR WHEEL SPROCKET - 1973 AND LATER (Figure 2-14)

To remove rear wheel sprocket (15), remove 5 bolts (13) and locknuts (14).

When assembling sprocket to hub, make sure clamping faces on hub and sprocket are clean. Tighten bolts to 35 ft-lbs torque.

SPOKING WHEELS - 16 INCH

GENERAL

Spoke holes in hub flanges are in two rows around flange, ten inner row holes and ten outer row holes in each flange. All spokes must be inserted from inside of flange.

ASSEMBLING SPOKES (Figures 2-18, 2-19)

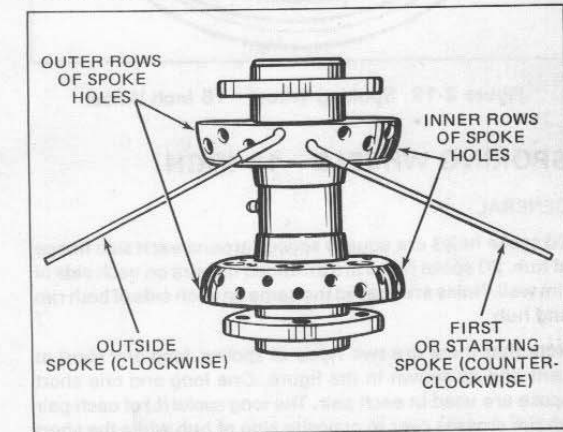

Figure 2-18. Starting Spokes in Wheel Hub - 16 Inch Wheel

1. Place hub on bench with one of the flanges up.
2. Insert spokes in ten inner spoke holes of hub flange (see Figure 2-18).
3. Swing loose end of spokes counterclockwise as far as hub will allow without turning hub.
4. Place rim over hub either side down and insert spokes in upper row of holes in rim that angle in same direction as spokes. Just start nipples on spokes as they are inserted in rim.
5. Insert spokes in outer ten holes of flange and swing spokes clockwise (see Figure 2-19).
6. Select any outer spoke, cross it over four inner spokes (A, B, C and D) and insert spoke in nearest upper rim hole and start nipple. Follow same procedure with balance of spokes.
7. Turn rim and hub over. Repeat operations 2, 3, 5 and 6, except in operation 3, swing spokes clockwise and in operation 5 swing spokes counterclockwise.

NOTE

Outer spokes on both sides point in same direction.

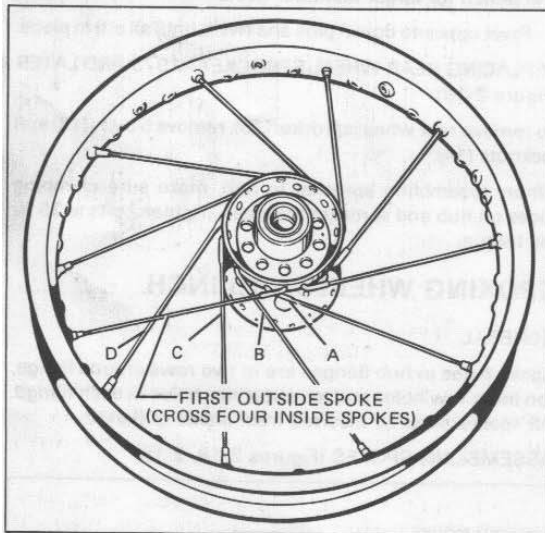

Figure 2-19. Spoking Wheel - 16 Inch Wheel

SPOKING WHEELS - 19 INCH

GENERAL

20 spoke holes are equally spaced around each side flange of hub. 20 spoke holes are arranged in pairs on each side of rim well. Holes are spaced the same on each side of both rim and hub.

Note that there are two types of spokes, long and short with bent end as shown in the figure. One long and one short spoke are used in each pair. The long spoke (L) of each pair on rim crosses over to opposite side of hub while the short spoke (S) of each pair on rim connects to same side of hub. Spoke arrangement is shown in Figures 2-20 and 2-21.

ASSEMBLING SPOKES (Figures 2-20 and 2-21)

1. Place hub on bench with one of the flanges up.
2. Insert 10 short spokes in every other hole from outside of flange.
3. Insert 10 long spokes in remaining holes.
4. Turn hub over on bench.

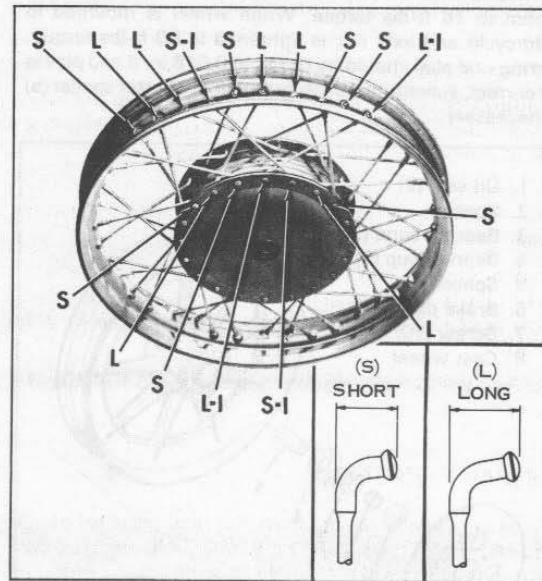

Figure 2-20. Front Wheel Lacing

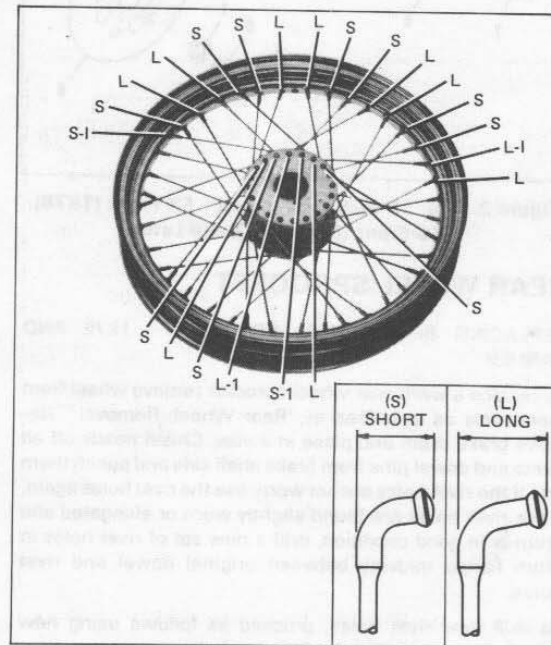

Figure 2-21. Wheel Lacing - 19 Inch Wheel (1973 and Later)

5. Locate a long spoke in the bottom flange. Use a straight edge and sight down across the flanges. Line up straight edge with the long spoke. Insert a short spoke in the first hole to the right of the straight edge. Insert remaining short spokes in alternate holes.

6. Insert 10 long spokes in remaining holes.

7. Swing short spokes counterclockwise and long spokes clockwise crossing underneath short spokes and forming pairs.

8. Place rim over hub (either side down).

9. Insert long spokes into right (clockwise hole) of each pair of holes that angles in same direction as spoke on opposite side of rim well. See L-1 in Figures 2-20 and 2-21.

10. Insert short spokes into right (clockwise hole) of each pair on near side of rim well that angles in same direction as spoke. See S-1 in Figures 2-20 and 2-21.

Short spokes will enter 14th hole to left of clockwise long spoke hole in rim. Repeat for remaining spokes. Start nipples on spokes as they are inserted in rim until all spokes are secured.

11. Turn wheel over and repeat procedure for spokes on the other side.

TRUING WHEELS

1. Install truing arbor in wheel hub and place wheel in Wheel Truing Stand, Part No. 95500-29A. Secure arbor nuts so that hub will turn on its bearings.

2. Turn each nipple on just far enough to cover spoke threads.

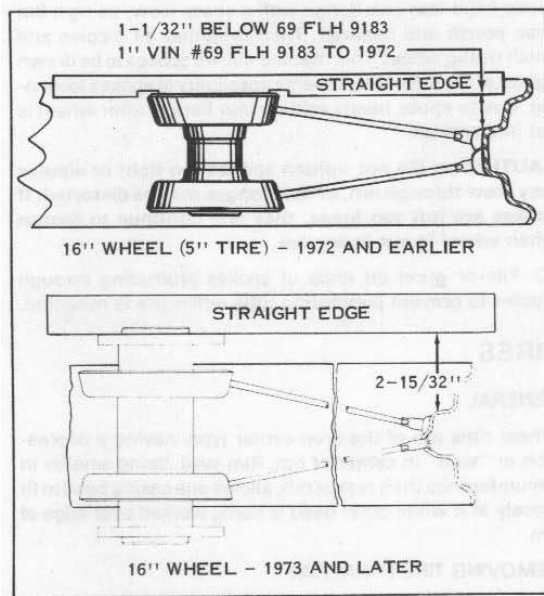

Figure 2-22. Centering Wheel Rim - 16 Inch

3. Start at valve hole and tighten all nipples three full turns each, using special Nipple Wrench, Part No. 94681-39. If further tightening is needed to pull spokes snug, tighten all nipples one full turn at a time until spokes are snug.

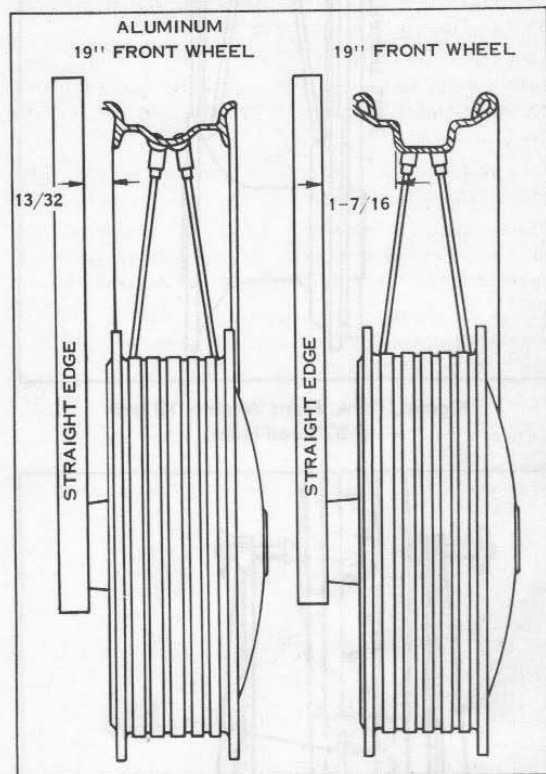

Figure 2-23. Front Wheel - 19 Inch (1972 and Earlier)

4. Check rim for centering sideways with hub, for running true sideways and concentricity. Centering rim sideways with hub and truing rim sideways must be done as one operation.

5. Rim must be properly centered sideways in relation to hub for correct alignment and "tracking" of front and rear wheels. Figures 2-22, 2-23 and 2-23A show method of using a straightedge to determine correct sideways centering of wheel rims as specified. Place straightedge across hub on brake side and measure the distance from straightedge to rim well as shown. Note that late 1969 to 1972 Electra Glide models have rim laced off center. Rims 1973 and later are centered on hub which includes cast wheels.

6. Adjust truing stand gauge to side of rim well as shown in Figure 2-24 so rim at highest point will strike gauge as wheel is rotated slowly. Loosen nipples at highest point of rim on gauge side and tighten nipples on opposite side the same amount. Repeat this operation until rim runs true sideways. Reverse loosening and tightening of nipples as explained above if rim moves too far away from gauge. After each loosening and tightening of spokes, check rim in relation to hub as explained in above paragraphs. Rim should be trued to within 1/32 in. sideways runout.

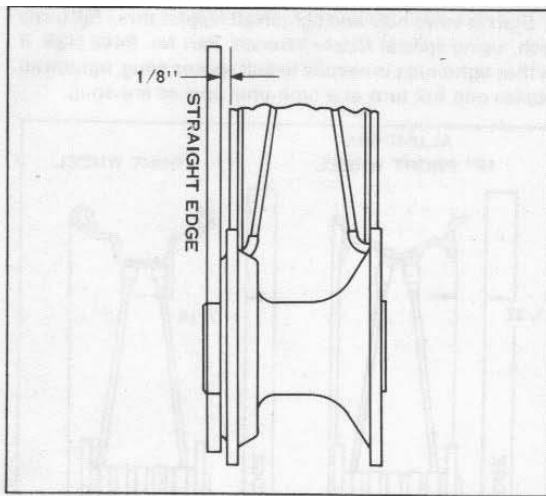

Figure 2-23A. Front Wheel - 19 Inch (1973 and Later)

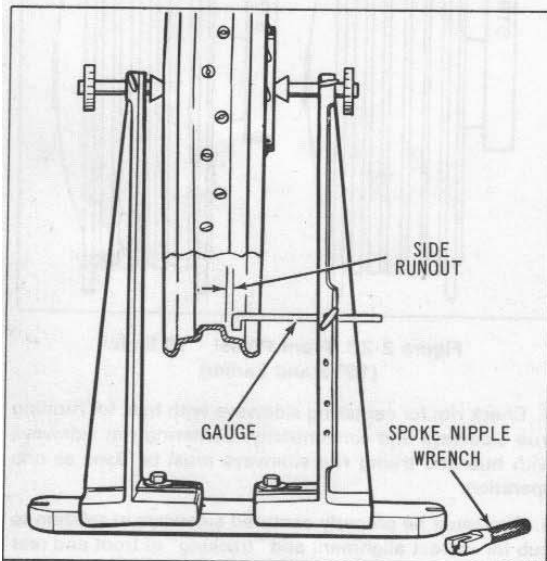

Figure 2-24. Truing Rim Sideways

7. After rim has been centered sideways with wheel hub and runs true sideways, check it for concentricity. Adjust truing stand gauge to rim tire bead seat as shown in Figure 2-25. If rim runs eccentric (radial runout), nipples must be loosened at points rim does not contact gauge, and nipples tightened at points rim contacts gauge. Amount nipples are to be loosened or tightened is determined by the amount rim is out of round. Rim should be trued to 1/32 in. or less radial runout.

8. After above operations have been checked and corrected, start at valve hole and tighten nipples one turn at a time all the way around rim until spokes are normally tight. While tightening nipples, repeatedly check rim with gauge according to instructions in steps 4 through 7.

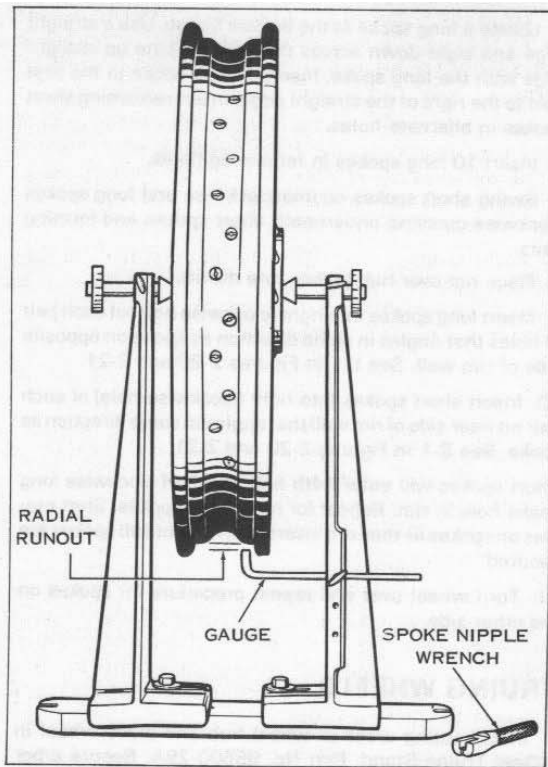

Figure 2-25. Truing Rim Concentric with Hub

9. After all nipples have been pulled up until spokes are normally tight and wheel is true, or nearly so, seat each spoke head into hub flange with a sharp blow, using a flat nose punch and hammer. Then retighten all nipples and finish truing wheel. This method allows spokes to be drawn tighter at the start and prevents possibility of spokes loosening, due to spoke heads seating into flange, after wheel is put into service.

CAUTION — Do not tighten spokes too tight or nipples may draw through rim, or hub flanges may be distorted. If spokes are left too loose, they will continue to loosen when wheel is put in service.

10. File or grind off ends of spokes protruding through nipples to prevent puncturing tube when tire is mounted.

TIRES

GENERAL

Wheel rims are of the drop-center type, having a depression or "well" in center of rim. Rim-well, being smaller in circumference than rest of rim, allows one casing bead to fit loosely in it while other bead is being worked over edge of rim.

REMOVING TIRE FROM RIM

1. Remove wheel; lay wheel on its side.
2. Remove valve cap and valve core to free all air from tube.

3. Loosen both beads from rim flanges by stepping on sides of tire or by using a tire tool. Stand or kneel on tire opposite valve to push bead into rim-well. Coat tire and rim with tire soap.

4. Using tire tools (not sharp instruments), start upper bead over edge of rim at valve. Don't use force when starting bead over edge of rim with tire iron, because bead wires may be broken or stretched and tire ruined. Carefully remove tube before attempting to remove second bead.

5. Push lower bead into rim-well on one side and insert tire iron on opposite side and pry bead over flange. After a portion of second bead is started over rim edge, tire can be further removed from rim without aid of tire iron.

NOTE

It is not always necessary to completely remove casing from rim. Removing one side allows tube to be removed and reinstalled and also allows inside of casing to be inspected.

MOUNTING TIRE ON RIM

Before installing tube in tire, all dust and dirt, particularly hard particles which might chafe an inflated tube, must be removed. Wipe tube and inside of tire thoroughly with clean, dry cloth. If rim is dirty or rusty, clean with a stiff wire brush. Be sure to examine a used tire carefully for fabric injuries that may damage tube.

Before mounting tire, see that rubber rim strip is in place in rim-well, and that rim strip valve hole registers with valve hole in rim.

WARNING — Use correct inner tube for tire size. See "Tire Data" Section 1.

1. Insert tube in tire (placing valve at tire balance mark). Swab thoroughly all around base of tube, between the tube and side walls of tire with a heavy suds solution of tire mounting compound and water. Bead seat of tire should not be coated. Inflate tube just enough to round it out. With wheel lying flat, place tire on rim and align valve with hole in rim. Mount tire so that arrow on sidewall points in direction of wheel rotation. If applicable, balance mark on tire sidewall should be at valve stem.

2. Push bottom bead into rim well near valve and hold in well while forcing remaining portion of bead over rim flange with a tire tool.

3. Spread tire and insert valve through hole in rim.

4. Force upper bead over rim flange and into well at point opposite valve. Stand or kneel on this side of tire to hole it in well and pry remaining portion of tire over rim flange. While forcing bead over rim flange, keep as much bead as possible in rim well. Be careful not to damage beads or pinch tube. Inflate tire to recommended pressure and check valve for leak. See tire inflation pressures in "Tire Data," Section 1A.

5. After inflating to recommended pressure, completely deflate to smooth out any wrinkles in tube and allow tube to find its place, free from strain or stress. Again inflate to recommended pressure and check valve for leak.

CHECKING TIRE TRUENESS SIDEWAYS (LATERAL RUNOUT)

1. Check runout by turning wheel on axle, measuring amount of sideways displacement from a fixed point near the tire (see Figure 2-26).

2. Tire tread runout should be no more than 3/64 in. If tire tread runout is more than 3/64 in., remove tire from rim and check rim bead side runout to see if rim is at fault (see "Truing Wheel").

3. If rim side runout is less than 1/32", tire is at fault and should be replaced. If rim side runout is more than 1/32", correct by tightening selected spoke nipples as outlined previously, reinstall old tire and recheck tire tread lateral runout.

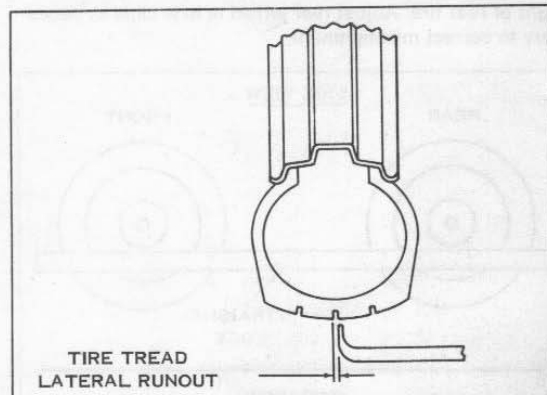

Figure 2-26. Checking Tire Lateral Runout

CHECKING TIRE ROUNDNESS (RADIAL RUNOUT)

1. Check runout by turning wheel on axle, measuring tread runout (see Figure 2-27).

2. Tire tread runout should be no more than 3/32". If tire tread runout is more 3/32", remove tire from rim and check rim bead runout to see if rim is at fault (see "Truing Wheel").

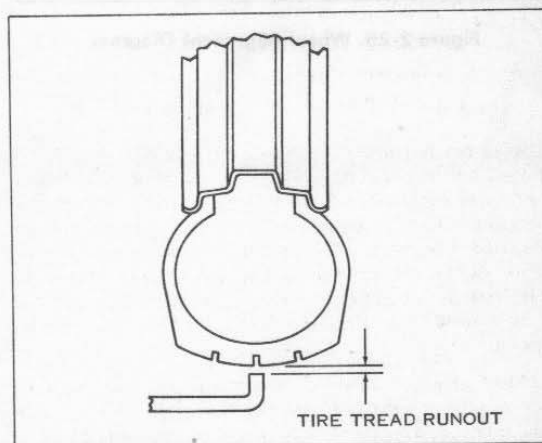

Figure 2-27. Checking Tire Radial Runout

3. If rim bead runout is less than 1/32", tire is at fault and should be replaced. If rim bead runout is more than 1/32" correct by tightening selected spoke nipples as outlined previously then reinstall tire and recheck tire tread runout.

WHEEL ALIGNMENT

NOTE

Rims and tires must be true before checking wheel alignment, as outlined in previous paragraphs.

Front and rear wheels should be in perfect alignment. This can be checked on the motorcycle with a straight wooden board or length of string by placing against rear tire sidewall as far up toward axles as possible. Straightedge should be parallel to tires (see Figure 2-28). On 1970 and later FL models, 5.10 x 16 size front tire should be offset 3/16 in. to right of rear tire. Adjust rear wheel in axle clips as necessary to correct misalignment.

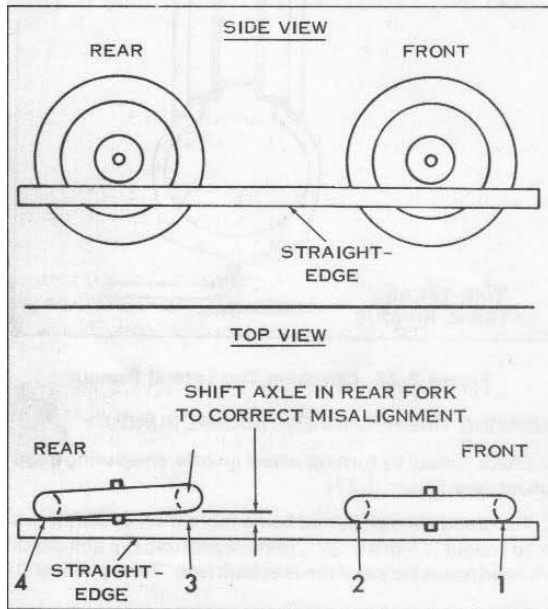

Figure 2-28. Wheel Alignment Diagram

WHEEL BALANCING

Wheel balancing is recommended to improve handling and reduce vibration, especially at high road speeds.

Harley-Davidson has made available the following spoke balance weights which press over the spoke nipple.

- 1 oz. weight, Part No. 95582-47
- 3/4 oz. weight, Part No. 95581-47
- 1/2 oz. weight, Part No. 95578-41



Cast aluminum wheels require the special self-adhesive weights listed below:

- Aluminum color
- 1 oz. weight, Part No. 95588-75
- 1/2 oz. weight, Part No. 95587-75



- Black
- 1 oz. weight, Part No. 95591-77
- 1/2 oz. weight, Part No. 95590-77

Self adhesive wheel weights should be applied to the flat surface of the rim. Make sure that area of application is completely clean, dry and free of oil and grease. Remove paper backing from weight and press firmly in place so that arrow on weight points in the direction of wheel rotation. If 1 oz. or more of weight must be added at one location, split the amount so that half is applied to each side of the rim. Wheel should not be used for 48 hours to allow adhesive to cure completely.

In most cases, static balancing using wheel truing stand, Part No. 95500-29A, will produce satisfactory results. However, dynamic balancing, utilizing a wheel spinner, can be used to produce finer tolerances for best high speed handling characteristics. Follow the instructions supplied with the balance machine you are using. The maximum weight permissible to accomplish balance is 3-1/2 oz. total weight applied to the rim. Wheels should be balanced to within 1/2 oz. at 60 mph.

HANDLEBAR

THROTTLE CONTROL - SPIRAL TYPE

GENERAL

Handlebar throttle control must operate freely. If a control becomes stiff and hard to adjust, parts must be removed and cleaned of caked grease, gum and dirt. A kinked control wire or cap must be replaced.

DISASSEMBLING (Figure 2-30)

1. Disconnect control coil and wire at carburetor.
2. Insert a large screwdriver through hole in end of grip (Figure 2-28) and loosen handlebar end screw (1). Handlebar end screw and spring (2) will remain inside grip. Remove grip sleeve assembly (3), exposing working parts.

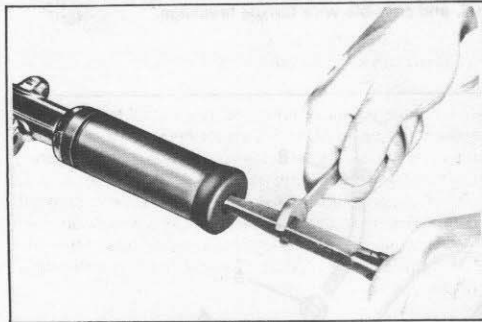

Figure 2-29. Removing Handlebar Control (Spiral Type)

3. Slip two rollers (5) off roller pin (4) and remove roller pin from plunger (6). Plunger with control wire (8) may be pulled through handlebar. If the control wire is broken, remove lower end at carburetor or circuit breaker. The control wire is fastened into the end of the plunger by means of set screw (7).

4. If control coil is to be removed, loosen the lock screw under the horn or starter button retainer on the handlebar that positions the coil end plug (9) in handlebar. The throttle end plug lock screw is exposed on the underside of the right handlebar. After loosening, control coils and end plugs may be pulled out of handlebar ends.

INSPECTION AND REPAIR

Clean all parts in solvent. Be sure they are free from rust, gum and dirt. Inspect all parts including inside of grip and replace all worn parts.

ASSEMBLING (Figure 2-30)

1. Slip control coil through handlebar and secure at end plug with lock screw through handlebar (screw must register in groove of end plug). Slip roller pin through plunger and assemble rollers to ends of roller pin, rounded side out. Attach control wire to plunger assembly by means of the set screw (7).

2. Apply a light coat of graphite grease or oil to control wire as it is inserted into coil. Lubricate remaining parts with grease. Turn grip onto handlebar with rollers following spiral grooves inside grip.

3. Handlebar end screw may be started without danger of crossing threads by holding grip sleeve assembly back slightly when starting screw in handlebar end. This squares screw with end of grip sleeve, aligning threads. Tighten screw securely.

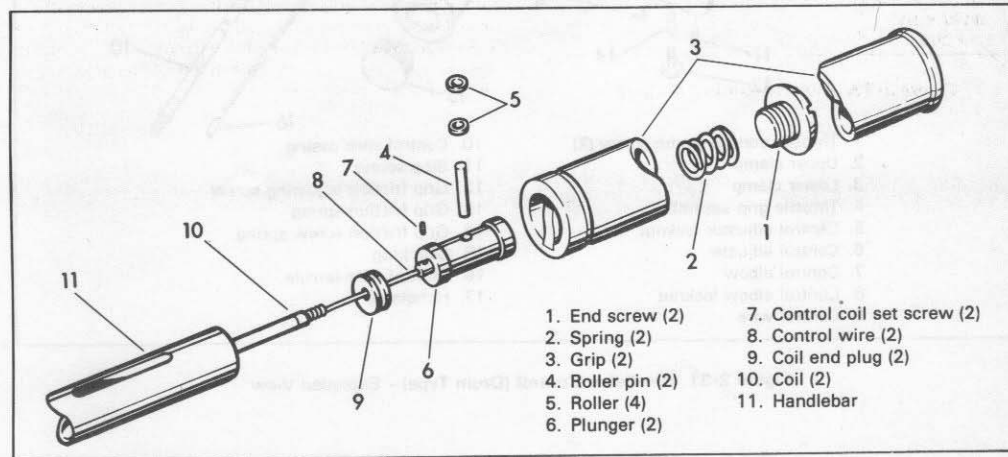

Figure 2-30. Handlebar Control (Spiral Type) - Exploded View

4. Connect throttle wire at carburetor throttle wire block. Adjust throttle control so throttle closes and opens fully with grip movement. Allow about 3/8 in. of throttle control coil to extend beyond carburetor control coil clip when throttle is in a closed position.

THROTTLE CONTROL - DRUM TYPE

GENERAL

Control must operate freely and carburetor throttle must return to closed (idle) position with friction adjusting screw (12, Figure 2-31) backed off. If control becomes stiff and does not return properly, it should be disassembled, cleaned and inspected.

DISASSEMBLING AND ASSEMBLING (Figure 2-31)

Remove two control coil clamp screws (1), upper clamp (2), lower clamp (3). Unhook ferrule end of control wire (9) from grip assembly (4) which is free to come off handlebar end (17).

To remove cable (9), disconnect it at carburetor throttle lever, unsolder or cut off ferrule (16) and pull wire out of lower clamp (3). Parts 5, 6, 7, 8 and 10 are now removable. Replace a worn or bent control wire with a new one through parts 5, 6, 7 and 8 and install in casing (10) applying graphite grease to wire. Solder ferrule on wire flush with end of wire.

Apply a light coat of graphite grease to handlebar (17) end and inside surfaces of clamps (2 and 3).

Connect ferrule end of wire to notch in drum and assemble grip (4) on handlebar between clamps. Be sure hole in friction spring (13) is in place on end of screw (12).

After assembling parts and connecting wire end to throttle lever, check for proper operation - that is, with friction screw (12) loosened, torsion spring on carburetor throttle shaft must return parts to closed throttle (idle) position.

With handgrip turned to throttle fully opened position, adjust stop screw (11) using 2 MM hex (Allen) wrench to limit travel. Important! This should be done to prevent excessive pull, and possible wire ferrule breakage.

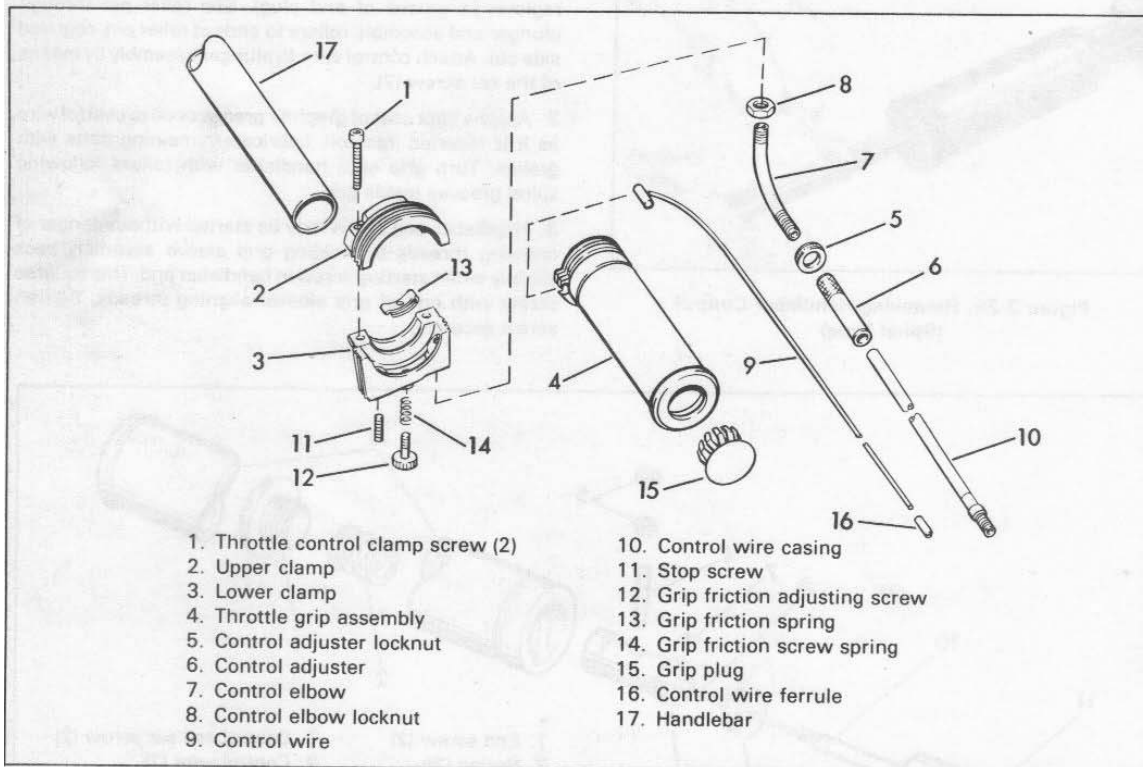

Figure 2-31. Handlebar Control (Drum Type) - Exploded View

FRAME

To rough check a frame for correct alignment, see Figure 2-32. The dimensions shown will provide basic information to determine whether a frame is enough out of alignment to require a major realigning job or replacement.

Because straightening a badly bent frame requires special tools and fixtures for holding, bending and gauging, this service is only offered by some of the larger dealerships.

Check entire frame for any signs of cracking and for signs of red oxide (rust) at frame connections. Frame should either be replaced or repaired by a certified welder.

NOTE

Replace all badly bent or broken frames. The cost of repair would be prohibitive.

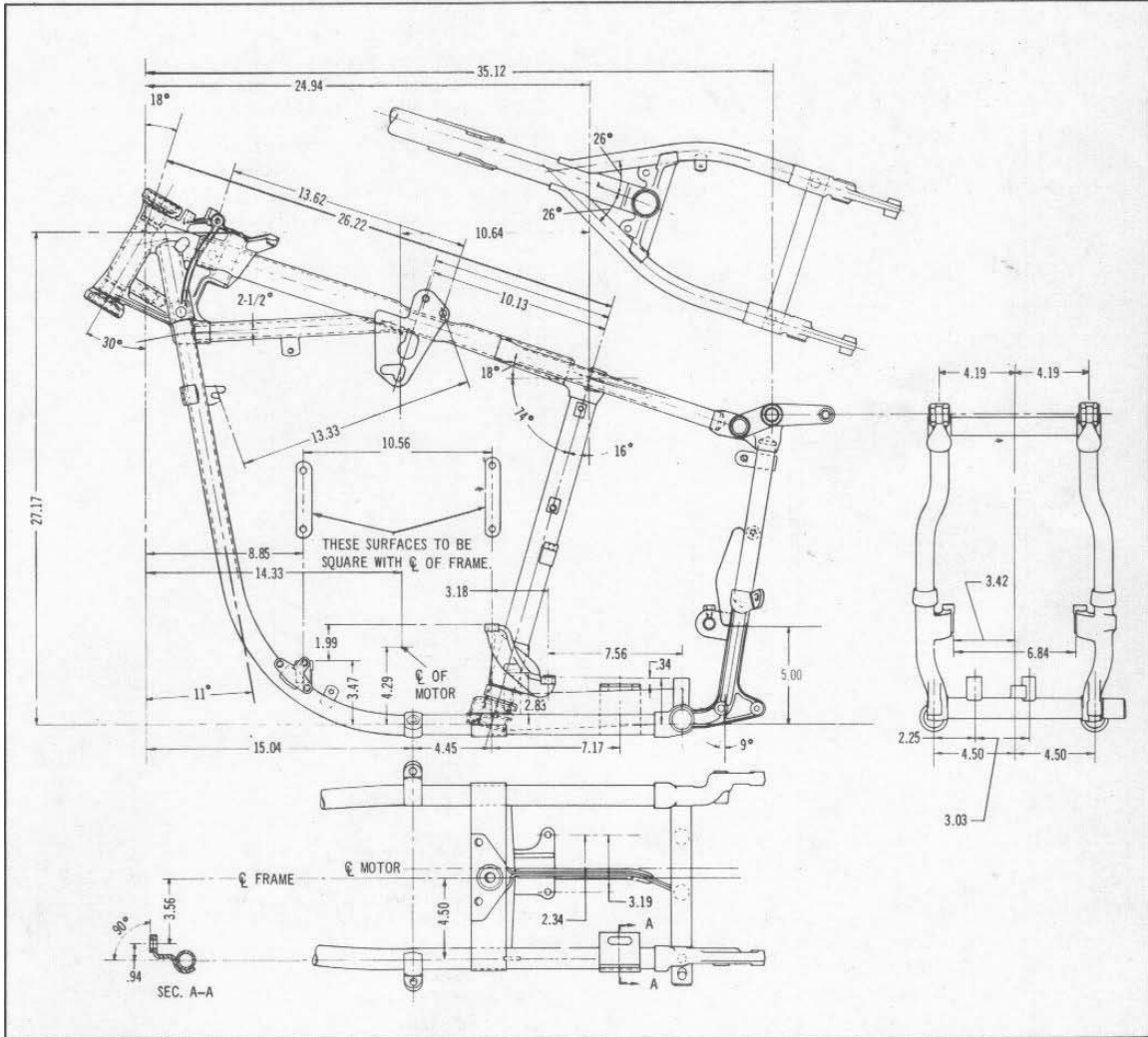

Figure 2-32. Frame with Basic Dimensions

FORKS

GENERAL

The front fork is comprised of two sets of telescoping tubes that work against springs, with an oil filled (hydraulic) dampening mechanism to control the action. The unit is engineered to give long service with a minimum of repair. Front fork oil should be changed at the initial 500 mile interval and at 5000 mile intervals thereafter.

NON-ADJUSTABLE

Non-adjustable forks are for use on a solo motorcycle. The fork "trail" (the distance, at ground level, from the fork stem axis to a perpendicular through the wheel axle) is set and cannot be adjusted.

ADJUSTABLE

The adjustable fork is for use on a motorcycle which operates with and without a sidecar. It is essentially the same as the non-adjustable fork except it has a two-position bracket that allows the trail to be changed for best solo or sidecar-equipped operation and a steering damper adjusting mechanism which dampens the steering for operation with sidecar. All other adjustments and repairs are made exactly as on the non-adjustable fork. This fork may be recognized by the reversible bracket bolt washers, bolt and stem design (18, 19, 20, Figure 2-36) as described in "Adjusting Front Fork Trail."

CHANGING OIL

Remove fork upper bracket bolt or filler screw and washer. Remove drain plug at the outside bottom of each slider tube and drain. Draining speed will be increased by gently flexing the fork as it empties. Replace drain plugs and pour specified amount of Harley-Davidson Type B Fork oil into each tube. Measure amount very carefully. Flow of oil into tubes will be increased if fork is worked up and down during filling operation. Replace upper bracket bolts and tighten securely.

Model	Year	Amount		Fork Oil Type
		Wet	Dry	
FX/FXE/ FXS	1972 and Earlier	5-1/2 oz.	6-1/2 oz.	Harley-Davidson Type B
	1973 and Later	5 oz.	6 oz.	Harley-Davidson Type B
FL/FLH	Mid 1977 and Earlier	6-1/2 oz.	7 oz.	Harley-Davidson Type B
	Late 1977 and Later	7-3/4 oz.	8-1/2 oz.	Harley-Davidson Type B

The fork filling device shown in Figure 2-33 will hasten and simplify the filling operation. The unit consists of a Neoprene (not rubber) stopper to fit the hole in the top of the fork, a length of flexible tubing, a funnel and an appropriate size can, soldered to the top of the funnel.

1. To make a filler can, drill a dozen 1/4 in. holes in the bottom of a one quart tin can (2), near the outside edge. Shape the bottom of the can with a light hammer so that it is dished upward to assure complete draining of oil through the holes.

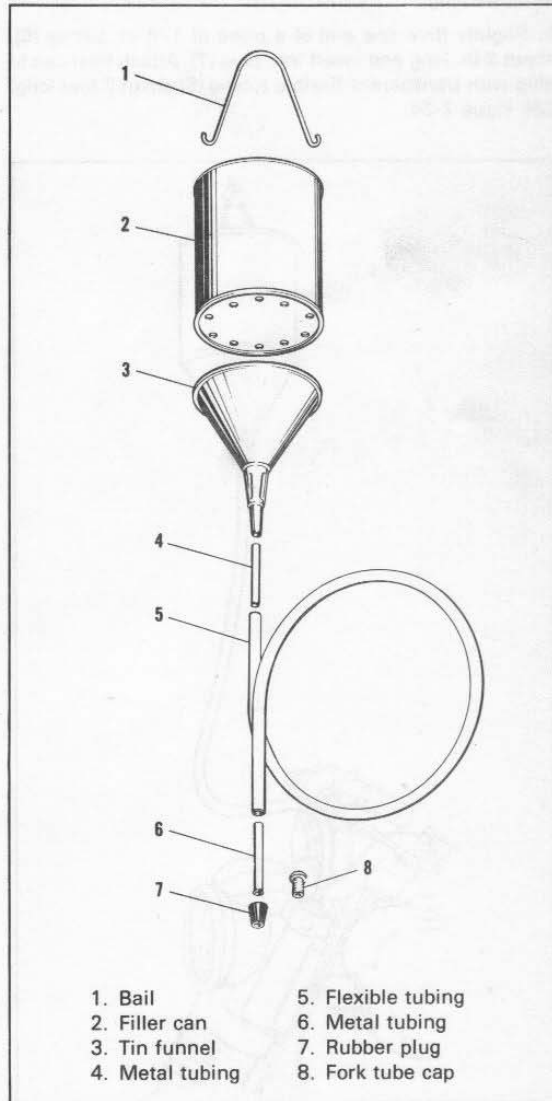

Figure 2-33. Fork Filler Can Components

2. Select a tin funnel (3) with the funnel mouth about the same size as the bottom of can (2). Swage and shape the funnel spout so that a piece of 1/4 in. metal tubing (4), about 2 in. long (a piece of fuel line is suitable) can be soldered into it. Solder (3) onto the bottom of (2). Improve and attach bail (1) to the filler can.

3. Make plug (7) from a rubber bottle stopper purchased from a drug store. Rubber stopper should be 1 in. to 1-1/8 in. long, and its largest diameter about 5/8 in.

4. Hold rubber stopper in vise and drill a 3/32 in. hole lengthwise through the center. Then enlarge the hole with a 1/4 in. drill. After hole is drilled in the stopper, insert a 1/4 in. rod through the hole and grind the stopper to a 5/8 in. diameter at the large end, and slightly under 1/2 in. diameter at the small end, straight taper between ends, to form the plug.

5. Slightly flare one end of a piece of 1/4 in. tubing (6), about 2 in. long and insert into plug (7). Attach filler can to plug with transparent flexible tubing (5) about 2 feet long. See Figure 2-34.

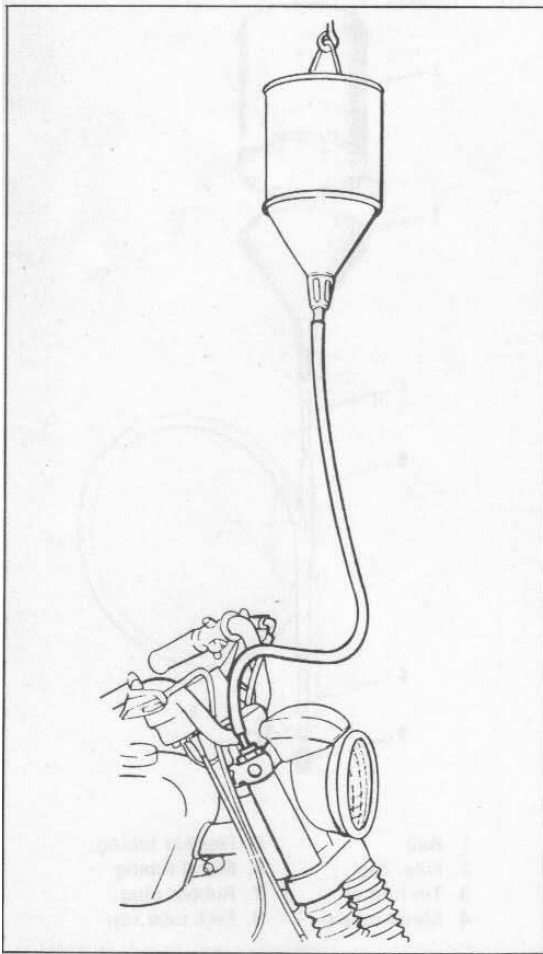

Figure 2-34. Filling Hydraulic Fork with Oil

6. Push the plug into the filler hole in fork top. Pour exact amount of oil into can. Work fork up and down. Air escaping through oil in filler can as fork is pushed downward will cause the oil to bubble violently, but because the bottom of the can serves as a baffle, no oil will be lost. Compressing the fork forces air out, releasing it draws oil into fork.

7. After the can appears to be empty, allow several minutes for can to completely drain, then work fork once more. This assures getting into fork side the full quantity of oil poured into can.

FL FRONT FORK

INSPECTION PROCEDURE (Early 1977 and Earlier)

If hydraulic fork does not work properly; that is, if it leaks oil or lacks original snubbing action, check the following before disassembling.

OIL LEAKS FROM VENT HOLE. If oil leaks from vent hole in upper bracket bolt (2, Figure 2-35) and filler screw (38, Figure 2-36) when fork flexes, check for over-filling. Drain and refill with exact amount of oil.

If oil leaks from vent hole in upper bracket bolt when fork tubes contain correct amount of oil, check breather valve in upper bracket bolt or hole. To replace breather valve, place bolt in vise and tap back three stake locks with small punch and hammer. Pry valve from recess with length of stiff wire. If unable to free valve, drill hole in valve larger and pry valve out with small pin or screwdriver. In some cases, it is necessary to drill and tap hole in valve and pull it out with tap. Insert new valve assembly and stake three spots on bolt lip.

If fork action is stiff or soft and spongy when breather valves are functioning and oil content is correct, damper valves in fork tubes are inoperative. Fork must be disassembled. If fork is submerged in water, oil must be replaced at once. Water will rust damper tube valve parts. In neglected cases, the valves may stick and result in almost no snubbing action.

If oil bypasses slider tube bushings and leaks at top of sliders, bushings are worn and must be replaced. To replace slider bushings, fork must be disassembled. If slider bushings are worn, water will contaminate oil. Oil will appear emulsified, aerated and light brown.

If fork slider has play on slider tubes, bushings are worn and must be replaced. Fork must be disassembled. However, it is not necessary to disassemble entire fork and steering head unless desired.

INSPECTION PROCEDURE (Late 1977 to 1978)

If the hydraulic fork does not work properly or an appreciable amount of oil leakage should develop, inspect the fork as follows:

Check the oil level in each fork side by completely draining and refilling fork as described in "Changing Fork Oil." Be sure correct amount of oil is used to refill fork tubes. An insufficient or excess supply of oil will result in faulty recoil action. When draining oil, check for signs of water in the oil. Oil will appear emulsified, aerated or light brown in color. Leakage of oil from forks would indicate replacement of seals and O-rings is needed. See "Disassembling Front Forks."

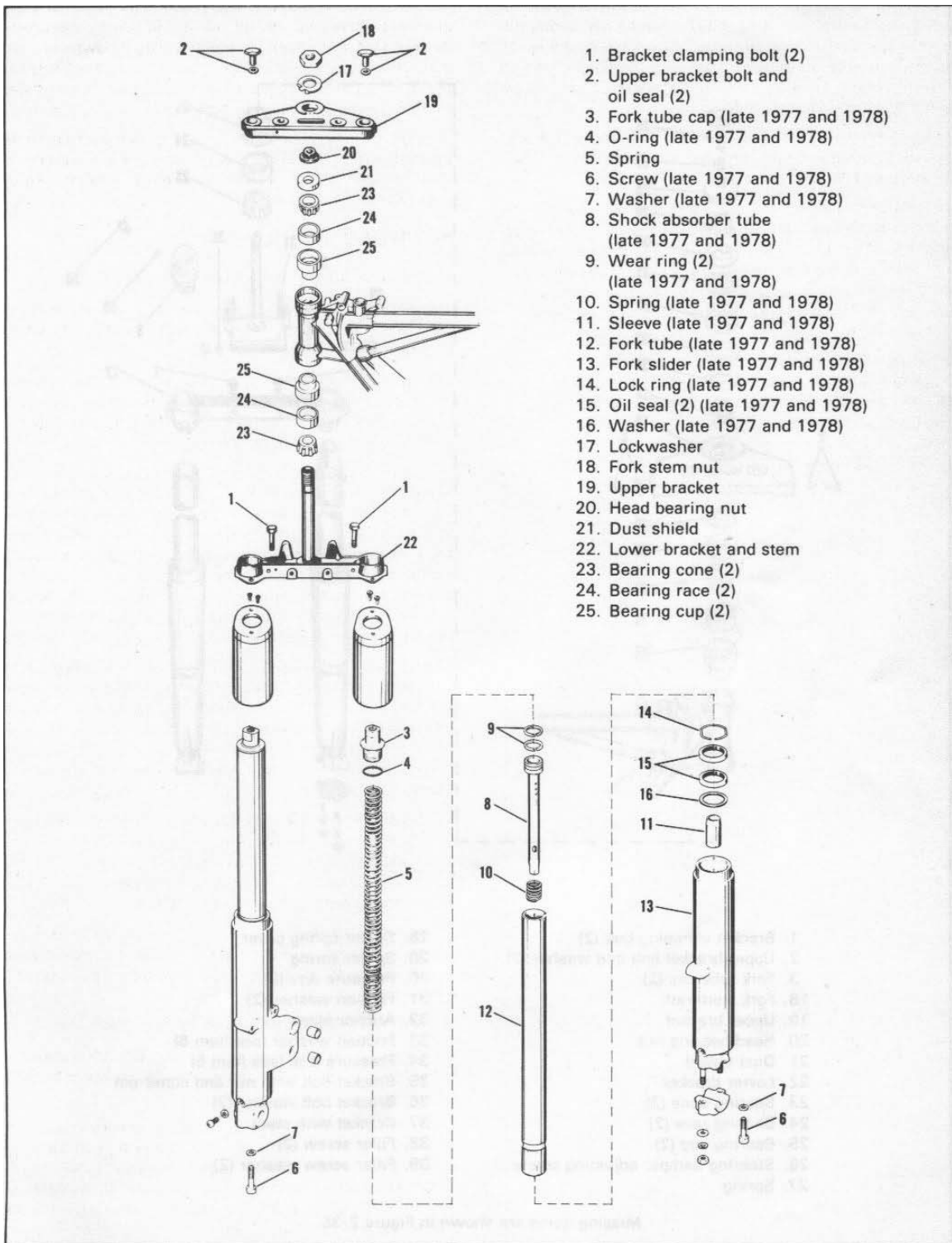
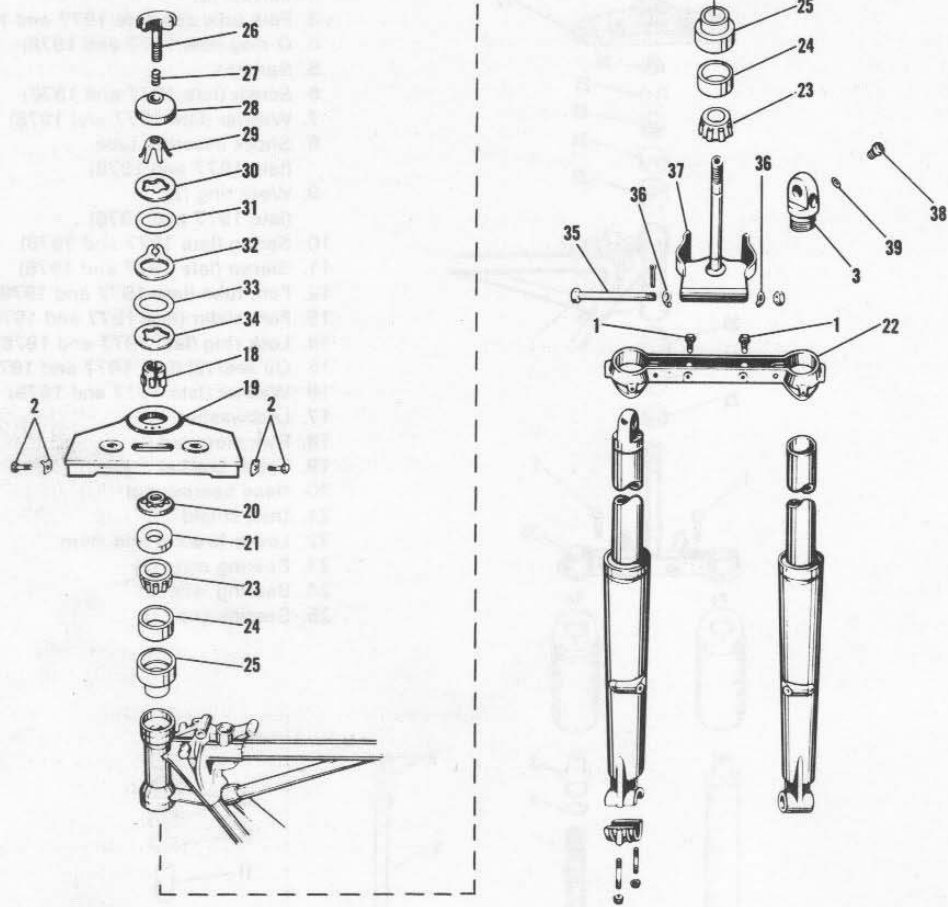

Figure 2-35. FL - Non-Adjustable Fork - Exploded View



- | | |
|--------------------------------------|--|
| 1. Bracket clamping bolt (2) | 28. Spider spring cover |
| 2. Upper bracket bolt and washer (2) | 29. Spider spring |
| 3. Fork tube cap (2) | 30. Pressure disc (2) |
| 18. Fork stem nut | 31. Friction washer (2) |
| 19. Upper bracket | 32. Anchor plate |
| 20. Head bearing nut | 33. Friction washer (see item 6) |
| 21. Dust shield | 34. Pressure disc (see item 5) |
| 22. Lower bracket | 35. Bracket bolt with nut and cotter pin |
| 23. Bearing cone (2) | 36. Bracket bolt washer (2) |
| 24. Bearing race (2) | 37. Bracket with stem |
| 25. Bearing cup (2) | 38. Filler screw (2) |
| 26. Steering damper adjusting screw | 39. Filler screw washer (2) |
| 27. Spring | |

Missing items are shown in Figure 2-35

Figure 2-36. FL - Adjustable Fork - Exploded View

If action of front forks remains unsatisfactory after oil change, completely disassemble and inspect forks.

ADJUSTING STEERING DAMPER

Turn steering damper adjusting screw (26, Figure 2-36) clockwise to apply dampening action and counterclockwise to reduce dampening action. Apply steering damper only when operating under conditions where some degree of dampening stabilizes steering. It is best to keep the damper set a little snug when operating with a sidecar.

ADJUSTING FRONT FORK TRAIL – ADJUSTABLE FORK (Figure 2-36)

To adjust fork trail for use with sidecar, turn off nut on bracket bolt (35). Tap bolt head back far enough to pry out washer (36). Grasp fork tubes and pull forward sharply. It may be necessary to loosen upper bracket bolts (2) to move fork forward or backward. Revolve bracket bolt washers 180 degrees until pin on washer is forward. Seat washer pin in slot in bracket (22) boss. Tap bracket bolt (35) into position and turn on nut.

To adjust fork for solo riding, follow same procedure except push fork tubes back and insert washer (36) so pins are rearward.

REMOVING FORK SIDES (Figures 2-35 and 2-36)

If necessary repairs involve only fork sides, the entire fork need not be disassembled.

To remove fork side, proceed as follows:

1. Remove the fairing, windshield, headlamp, headlamp housing, front wheel, brake caliper assembly, and front fender.
2. Loosen fork bracket clamping bolts (1). Remove fork upper bracket bolt and oil seal or bolt and washer (2). Pull fork side out bottom of lower fork bracket.

REMOVING FORK STEM AND BRACKET ASSEMBLY FROM STEERING HEAD

Non-Adjustable Fork (Figure 2-35)

Remove fork sides as described previously. Remove horn. Remove flasher mounting hardware.

Bend tab on lockwasher (17) down and remove fork stem nut (18). Lift up upper bracket (19) and handlebar assembly and set it aside. Use wrench, Part No. 96219-50 to remove head bearing nut (20). Remove dust shield (21). Pull lower fork bracket and stem (22) out bottom of frame steering head. Remove bearing cones (23).

Adjustable Fork (Figure 2-36)

Remove fork sides as described previously. Remove horn. Remove flasher mounting hardware.

Turn out steering damper adjusting screw (26) and lift out parts 27 through 34. Parts 30 and 34 may be loosened by inserting a screwdriver tip between parts and prying upward.

REPAIRING STEERING HEAD AND BEARINGS

Each steering head bearing consists of two pieces, the bearing outer race, and the roller bearing with inner race. The outer races are pressed into the steering head cups in the

frame head. The lower roller bearing is assembled over the fork stem and the upper roller bearing is held in place on the fork stem by the upper fork bracket and nut on the upper threaded end of the fork stem.

After fork is removed inspect bearings and races for pitting, roughness or wear. Roughness of the roller bearings can be determined by rolling the bearings on the bearing races by hand. If bearings or races require replacement it is best to replace them in sets.

To replace bearing races, knock head cup from steering head using a suitable drift. Press new bearing race in new head cup and then press assembly into frame head.

DISASSEMBLING FORK SIDE – EARLY 1977 AND EARLIER (Figure 2-37)

Turn out two slider tube plugs (1) and invert sliders to drain out oil and remove fork springs (2). Remove damper valve stud locknut (3) from bottom of slider and pull slider tube (4) out of slider (5). Pinch out snap ring (6) from lower end of slider tube and drop out damper tube lower bushing (8). Discard gaskets (7 and 9). Slide out damper valve assembly (10). Snap out spring ring (11), washer (12), felt washer (13) and pry out oil seal (14).

DISASSEMBLING FORK SIDE – LATE 1977 AND LATER (Figure 2-35)

Remove fork tube cap (3). Remove O-ring (4) from cap. Remove spring (5) and drain oil from fork side. Remove screw (6) and washer (7). Shock absorber tube (8) may now be pulled from fork side. Remove wear rings (9) from slots in shock absorber tube. Remove spring (10) and sleeve (11).

Separate fork tube (12) and fork slider (13) by pulling the two apart. Remove seals (15) only if they are to be replaced. Remove lockring (14) and then pry out seals (15). Discard the damaged seals. Remove washer (16).

Thoroughly clean and inspect each part. If inspection shows that any parts are bent, broken or damaged, those parts should either be replaced or repaired.

Inspect seals (15) for wear. If they were removed, they must be replaced. Inspect wear rings (9) on damper tube (8) and replace if excessively worn or damaged. Replace springs (5 and 10) if broken or distorted.

Inspect small hole in groove in lower end of fork tube (12) and see that it is not obstructed.

Make sure O-ring (4) is in good condition, without any irregularities, and that it provides proper sealing when in place.

Check washer (7) to see that it provides a good seal when used with its respective screw (6) to prevent oil leakage.

Repair bent or damaged fork tube (12) as described in "Straightening Fork Tubes" later in this section.

FRONT FORK SLIDER BUSHINGS – EARLY 1977 AND EARLIER

NOTE

Late 1977 and later forks do not have removable bushings. If slider is worn to excessive looseness on fork tube, slider must be replaced.

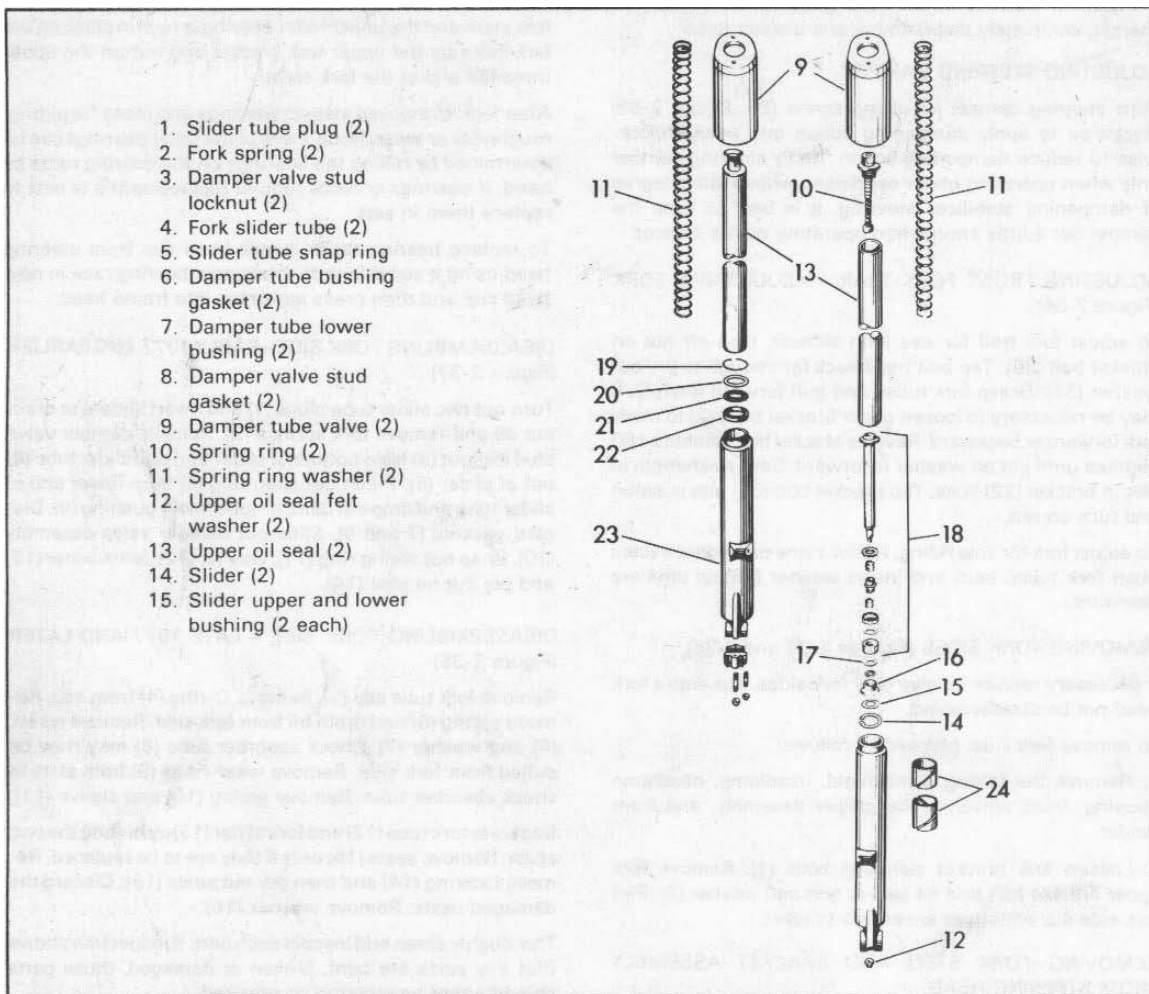

Figure 2-37. Fork Side (Early 1977 and Earlier)

The front fork slider bushings (15, Figure 2-37) may be replaced using four special tools.

1. Part No. 96255-50, Fork Slider Bushing Puller.
2. Part No. 96287-50A, Bushing Driver and Guide.
3. Part No. 96288-50, Guide.
4. Part No. 96300-50, Bushing Reamer and Pilots.

To remove upper fork slider bushings, position fork slider in vise as shown in Figure 2-43.

Remove spring ring, steel retaining washer and felt wiper from slider upper end. Pry out oil seal with large screwdriver.

Install Fork Slider Bushing Puller, Part No. 96255-50, so the three claws expand inside the tube under the upper, or shorter bushing. Place puller cap in oil seal counterbore, apply oil to screw threads and steel washer. Turn nut down against puller cap and use engine sprocket wrench on nut to extract bushing.

Remove lower bushing in the same manner.

New, replacement bushings are installed with Fork Slider Bushing Driver and Guide, Part Numbers 96287-50A and 96288-50.

Wash out fork slider and lubricate slider bore with engine oil. Position new lower bushing in bushing driver guide to compress bushing, then place driver guide with bushing in slider oil seal counterbore as shown in Figure 2-44.

Drive bushing through the driver guide into fork slider. Bushing is positioned correctly in slider bore when second groove from top on driver is flush with top edge of driver guide. Do not drive bushing deeper than specified, or it will collapse enough so it cannot be finish-reamed.

Install upper bushing in the same manner lower bushing was installed. Drive it into slider until lower groove on driver is flush with top of driver guide. This positions upper bushing 1/16 in. below slider oil seal counterbore.

The Fork Slider Bushing Reamer with pilots, Part No. 96300-50, is used to ream the bushings to finished size.

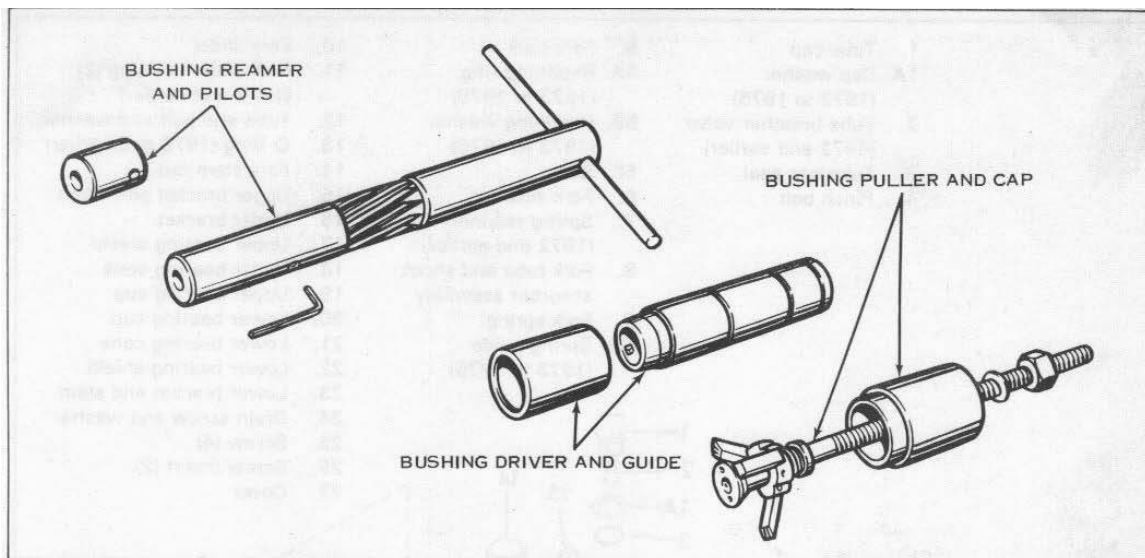

Figure 2-38. Fork Rebushing Tools

Attach long pilot to reamer as shown in Figure 2-45. The long pilot fits into the unfinished lower bushing, acting as a guide, while reaming the upper bushing. Do not drop reamer into bushing. Slowly lower reamer into cutting position and ream bushing, turning reamer clockwise. Continue turning reamer clockwise as it is being extracted when cut is finished.

Remove long pilot from reamer and attach short pilot. Finish lower bushing in same manner as upper bushing. Use caution when passing reamer cutters through the upper bushing.

ASSEMBLING FORK SIDES (Figures 2-35, 2-37)

Assembly is the reverse of disassembly with the following exception: Fill fork sides with specified amount of Harley-Davidson, Type B, fork oil.

INSTALLING FORK STEM AND BRACKET ASSEMBLY, FORK SIDES AND ADJUSTING STEERING HEAD BEARINGS (Figures 2-35, 2-36)

Assembly is the reverse of disassembly. Apply a heavy coating of grease to bearing cones.

After fork sides are assembled to upper and lower bracket, tighten fork bracket clamping bolts (1) to 22 to 26 ft-lbs torque.

Assemble front fender, brake caliper and wheel to motorcycle before checking head bearing adjustment.

Fork should have free movement to either side. There should be no noticeable shake or sideways movement of the front fork. To adjust steering head bearings, tighten or loosen head bearing nut (20) as required, while tapping on bracket (22).

When bearings are correctly adjusted, install fork stem nut (18) and bend up tab on lockwasher (17).

FX FRONT FORK

INSPECTION PROCEDURE (Figure 2-39)

If the hydraulic fork does not work properly or an appreciable amount of oil leakage should develop, inspect the fork as follows:

Check the oil level in each fork side by completely draining and refilling fork as described in "Changing Fork Oil." Insufficient oil in either fork side will result in faulty recoil action and excess oil will cause leakage from the top of fork tubes. When checking oil level in each fork side, also check for water in fork oil which will cause leakage from fork tube cap or oil to bypass fork slider bushings and seals. Oil will appear emulsified, aerated or light brown in color.

Check slider oil seals (5C) for wear or damage to lip which could cause oil leakage.

On 1972 and earlier models, if the fork does not function correctly after eliminating the possibility of water contamination or fork oil and incorrect oil level in fork sides, inspect the fork tube breather valve (2) for defective condition. Remove fork tube cap (1), submerge in water and blow compressed air through cap vent hole. Breather valve should not leak below 15 lbs air pressure. If breather valve is faulty, renew valve as described in "Replacing Breather Valve."

If snubbing action of the front fork remains unsatisfactory, bottoms on compression, stops suddenly on recoil and does not operate smoothly after eliminating malfunctions previously covered, disassemble fork as described in "Disassembling Front Fork Shock Absorber." Inspect shock absorber giving particular attention to the following parts (see Figure 2-40). Check fit of damper piston in fork tube and fit on shock absorber tube. Check seating of washer on upper and lower valve body faces. Replace worn or damaged parts.

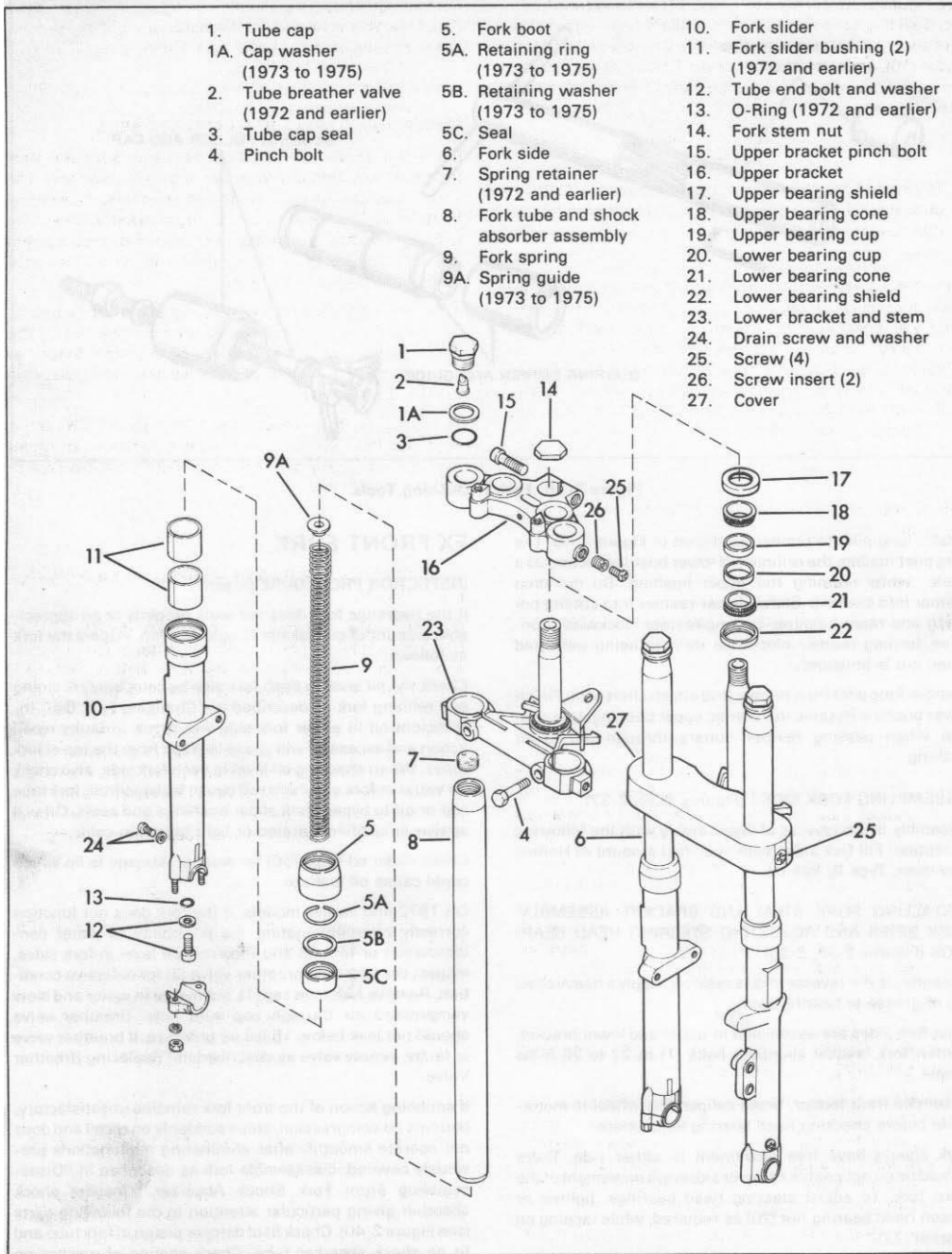

Figure 2-39. FX Front Fork - Exploded View

See Figure 2-39. Examine fork tube (8) for scoring and badly worn sliding surface. Inspect fork slider bushings (11) in fork slider (10) for wear and scoring. Insert tube (8) in fork slider (10), and work up and down. If tube has appreciable play in slider, replace slider bushings. See "Fork Slider Bushings."

NOTE

1973 and later sliders do not have removable bushings. If slider is worn to excessive looseness on fork tube, slider must be replaced.

If the front fork has been damaged, check the fork alignment. Inspect fork tubes and the fork stem and bracket assembly for bent or damaged condition. Tubes and fork stem and bracket assembly, that are badly damaged, must be replaced. If fork tube and fork stem and bracket assembly are only slightly damaged, they can be repaired as described in "Straightening Fork Tubes," and "Straightening Fork Stem and Bracket Assembly."

REPLACING BREATHER VALVE - 1972 AND EARLIER (Figure 2-39)

Remove fork tube cap (1). Place in vise and break three stake locks securing breather valve (2). Free valve from cap. When reassembling, coat breather valve seat with a light coat of Harley-Davidson "Gasket Eliminator," Part No. 99633-77, or a similar sealing agent. Seat rubber valve in cap and stake lock in three places.

REMOVING FORK SIDES (Figure 2-39)

Remove front wheel and brake assembly as described in "Wheel" section of this manual. Remove front fender. Remove bracket that attaches headlamp to the upper fork bracket and let hang loose by wiring harness.

Remove two screws (25) so cover (27) can be slid up out of the way, exposing the lower fork bracket. Loosen fork tube pinch bolts (4). Loosen screw (15) in upper fork bracket (16). Unscrew fork tube cap (1) from fork tube. Remove fork side (6) completely by sliding down and out of both upper and lower fork brackets. Drain oil from fork side.

REMOVING FORK STEM AND BRACKET ASSEMBLY FROM STEERING HEAD (Figure 2-39)

Remove fork sides as described under "Removing Fork Sides." Remove fork stem nut (14) and loosen fork upper bracket pinch bolt (15). Lift handlebar assembly from steering head with fork upper bracket (16) attached. Carefully position assembly away from working area. Be careful not to bend control wires more than necessary.

It is not necessary to disconnect clutch and brake hand-levers from handlebar, wiring harnesses or control cables from handlebar unless handlebar assembly is to be removed from motorcycle.

Remove upper bearing shield (17) and upper bearing cone (18). Drop fork stem and bracket assembly (23) and remove lower bearing cone (21) and lower bearing shield (22).

REPAIRING STEERING HEAD AND BEARINGS

Each steering head bearing consists of two pieces, the bearing outer race, and the roller bearing with inner race. The outer races are pressed into the steering head cups in the frame head. The lower roller bearing is assembled over the fork stem and the upper roller bearing is held in place on the fork stem by the upper fork bracket and nut on the upper threaded end of the fork stem.

After fork is removed inspect bearings and races for pitting, roughness or wear. Roughness of the roller bearings can be determined by rolling the bearings on the bearing races by hand. If bearings or races require replacement it is best to replace them in sets.

To replace bearing races (19 and 20, Figure 2-39), knock head cup from steering head using a suitable drift. Press new bearing race in new head cup and then press assembly into frame head.

DISASSEMBLING FORK SIDE - 1975 AND EARLIER (Figure 2-39)

On 1972 and earlier models, use Wrench, Part No. 94694-52, and disassemble retainer (7) from top of fork tube (8). Remove spring (9) and drain hydraulic fork oil from fork tube. Turn assembly upside down and remove bolt and washer (12). It may be necessary to insert Tool, Part No. 95991-69 or a long screwdriver into 3/32 wide x 1/2 long slot C (Figure 2-40) in upper end of shock absorber tube to keep it from turning while removing bolt (12). Free slider (10) from tube (8). On 1973 to 1975 models use Socket, Part No. 94556-73, with extension on upper end of shock absorber tube C (Figure 2-40) to keep it from turning.

DISASSEMBLING FRONT FORK SHOCK ABSORBER, 1971-1972 (Figure 2-40)

Shock absorber mechanism is part of fork tube (9). To disassemble, remove retaining ring (1) with Tru-arc pliers, Part No. 96215-49, and remove lower valve body (2), washer (3), upper valve body (4), and spring (5). Remove shock absorber tube (8) and remove retaining ring (6) and piston (7).

DISASSEMBLING FRONT FORK SHOCK ABSORBER - 1973 TO 1975 (Figure 2-40)

Remove retaining ring (1) from fork tube (13) with Tru-arc pliers, Part No. 96215-49. Remove valve parts as follows: lower piston (2), lower stop (3), orifice washer (4), valve (5), spring washer (6), valve body (7), remove retaining ring (8) with Tru-arc pliers. To disassemble upper stop (11), remove roll pin (10) from shock absorber tube (12).

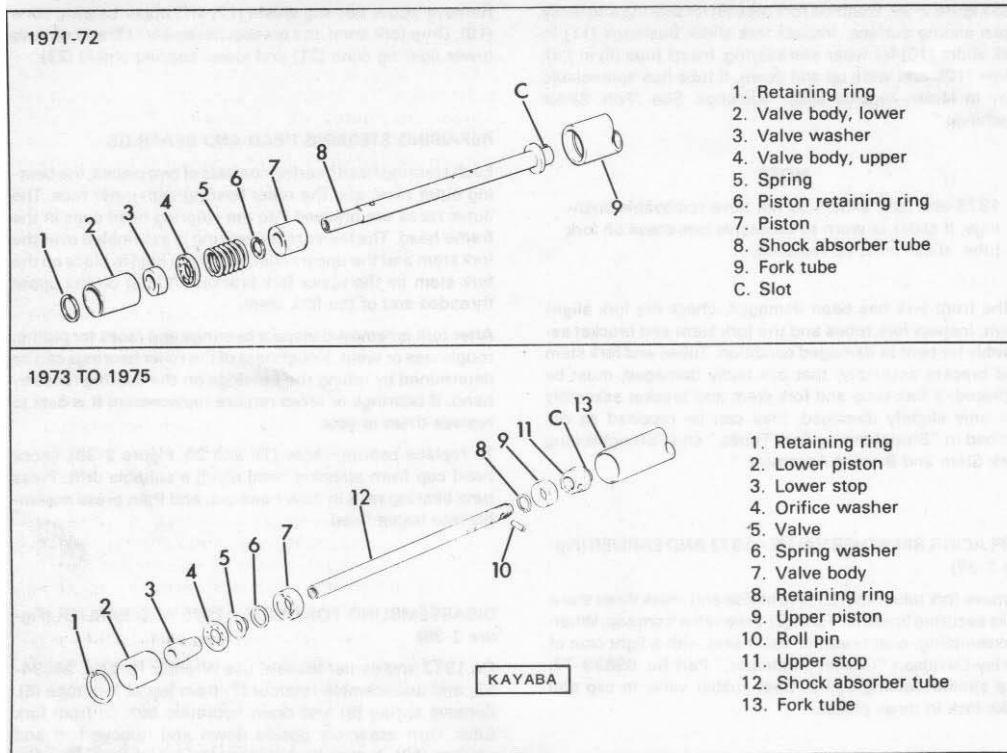

Figure 2-40. FX Front Shock Absorber - Exploded View

DISASSEMBLING FORK SIDE - 1976 TO 1978
(Figure 2-41)

Remove O-Ring (3) from inner groove in tube cap (1) and slide off washer (4). Pull spring (5) out of fork tube (2).

Check boot (11) where it rubs on fork tube (2). The tube should show a bright, shining surface, free of scoring or abrasions and the boot should present a good, continuous seal and not show excessive wear.

Replace spring (5) if broken.

Inspect small hole in groove in lower end of fork tube (2) and see that it is not obstructed.

Make sure O-ring (3) is in good condition, without irregularities, and that it provides proper sealing when in place.

Check both washers (7 and 16) to see that they provide a good seal when used with their respective screws (6 and 15) to prevent oil leakage.

Repair bent or damaged fork tube (2) as described in "Straightening Fork Tubes" later in this section. Reassemble parts in reverse order of disassembly.

FORK SLIDER BUSHINGS

NOTE

1973 and later forks do not have removable bushings. If slider is worn or excessive looseness on fork tube, slider must be replaced.

To remove upper fork slider bushings, insert the fork slider bushing puller and cap (1, Figure 2-42) into the fork slider a sufficient distance to allow the claws to extend below lower end of the upper fork slider bushing. Place puller cap into oil seal counterbore. Apply oil to screw threads and steel thrust washer and turn nut down against puller cap to remove all slack from puller assembly. Using a wrench, continue to turn nut against puller cap until bushing is removed (see Figure 2-43).

To remove lower fork slider bushing, follow same procedure used in removing upper fork bushing.

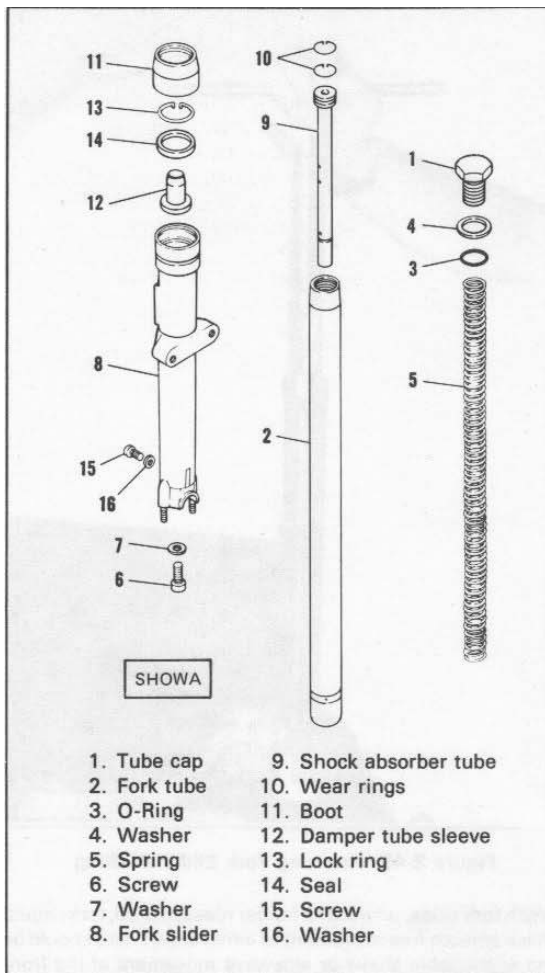

Figure 2-41. FX Front Fork - 1976 to 1978 - Exploded View

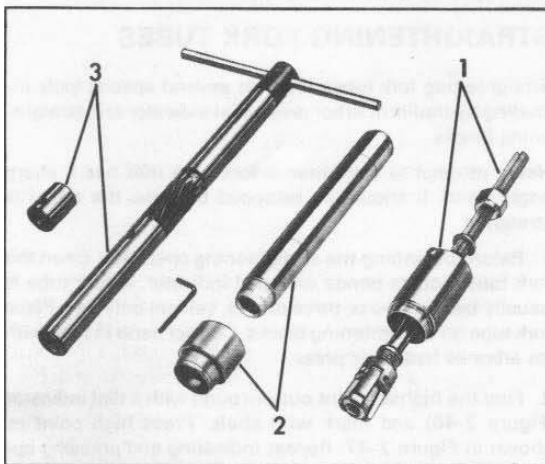

Figure 2-42. Fork Rebushing Tools

INSTALLING FORK SLIDER BUSHINGS
(Figure 2-44)

Before installing new fork slider bushings, thoroughly clean slider bore and lubricate with engine oil. Fork bushing driver and guide (2, Figure 2-42) is used to install fork slider bushings. Insert the bushing guide into the fork slider oil seal counterbore and insert the new lower fork slider bushing into the guide. The fork bushing driver has two grooves cut around its outside diameter which are used as depth gauges when driving in the bushings. The groove nearest the top of the driver is the depth gauge for the lower bushing, and the lower groove is the depth gauge for the upper bushing. The lower bushing is driven into the fork slider to the point where the upper groove on the bushing driver aligns with the top edge of the bushing guide.

NOTE

If the lower bushing is driven into the fork slider farther than specified, it will contact the bottom of the counterbore at lower end of fork bushing and bushing may be collapsed to the extent that it cannot be finish reamed.

When installing upper fork slider bushing, follow the same procedure used to install lower fork slider bushing. The upper fork slider bushing is driven into the fork slider the correct depth when the lower groove on the bushing driver is aligned with the top edge of the bushing guide.

Figure 2-45 shows reamer with long pilot attached as required for reaming upper bushings to finish size. The long pilot is of correct size to fit into the unfinished lower bushing and guide the reamer through the upper bushing.

CAUTION — Do not drop cutting edges of the reamer into bushing.



Figure 2-43. Removing Fork Slider Bushing



Figure 2-44. Installing Fork Slider Bushing

Slowly start cut, turning reamer clockwise. When removing reamer after bushing is reamed, continue turning clockwise and apply a slight upward pressure to remove reamer from the finished bushing. Install the short reamer pilot, shown under 3, Figure 2-42, on reamer to ream the lower bushing. The Allen wrench provided with the tool set is used to tighten or loosen reamer pilots on the reamer body.

ASSEMBLING FRONT FORK SIDES (Figures 2-39, 2-41)

Assembly is the reverse of disassembly with the following exceptions: Fill fork sides with specified amount of Harley-Davidson, Type B, fork oil.

INSTALLING STEM AND BRACKET ASSEMBLY, FORK SIDES AND ADJUSTING STEERING HEAD BEARINGS (Figure 2-39)

Assembly of the fork is the reverse of disassembly. Assemble the head cups, races, bearing cones and dust shields. Apply a heavy coating of Harley-Davidson Grease-All grease to bearing cones.

Insert fork lower bracket stem (23) up through steering head and assemble upper bracket (16) and stem nut (14) loosely. Install fork sides (6). With forks correctly aligned, tighten fork tube caps (1) with pinch bolts (4) loose. Install front fender and front wheel.

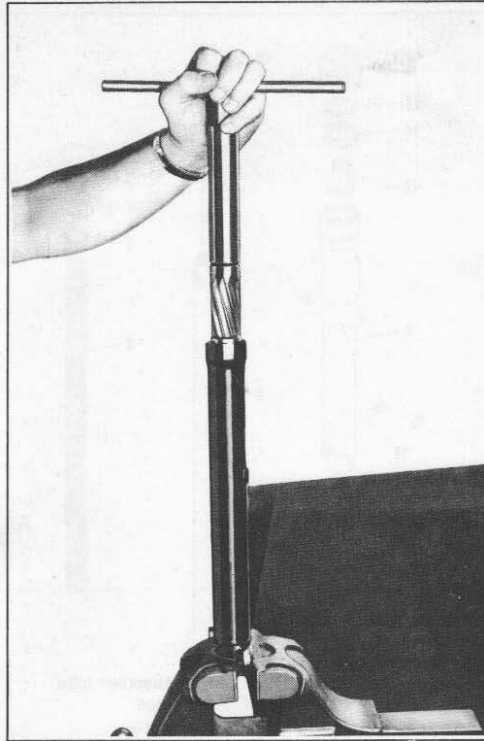

Figure 2-45. Reaming Fork Slider Bushing

With fork sides, wheel and fender reassembled, fork should have smooth free movement to either side. There should be no appreciable shake or sideways movement of the front fork. To adjust steering head bearings, tighten or loosen stem nut (14) as required, while tapping on bracket (16). When bearings are correctly adjusted, tighten pinch bolts (4 and 15) to 22 to 26 ft-lbs torque.

STRAIGHTENING FORK TUBES

Straightening fork tubes requires several special tools including hydraulic or arbor press, dial indicator and straightening blocks.

Never attempt to straighten a fork tube that has a sharp angle bend. It should be scrapped because the metal is stretched.

1. Before beginning the straightening operation, clean the fork tube. Locate bends with dial indicator. A fork tube is usually bent in two or three places, seldom only one. Place fork tube on straightening blocks. Correct bend in tube with an arbor or hydraulic press.

2. Find the highest point out-of-round with a dial indicator (Figure 2-46) and mark with chalk. Press high point as shown in Figure 2-47. Repeat indicating and pressing operations until tube is within 0.003 in. to 0.004 in. of being straight.

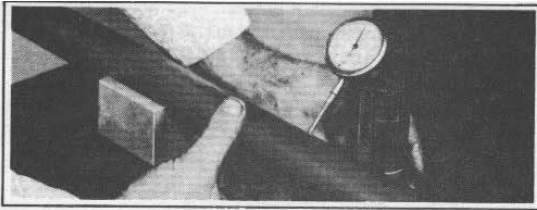

Figure 2-46. Indicating High Point

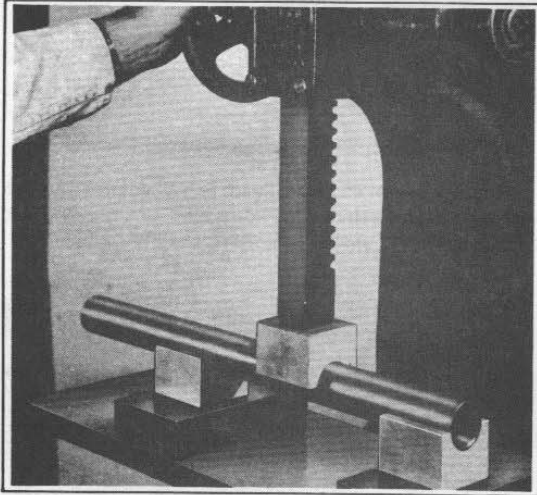

Figure 2-47. Pressing High Point

3. Sometimes fork tubes are out-of-round, especially at the point it is clamped in the fork bracket. Place tube in straightening blocks and press until perfectly round as shown in Figure 2-48, checking with dial indicator and micrometer. Finally, check tube by inserting in new fork slider. Work tube up and down. If it does not bind, it is straight.

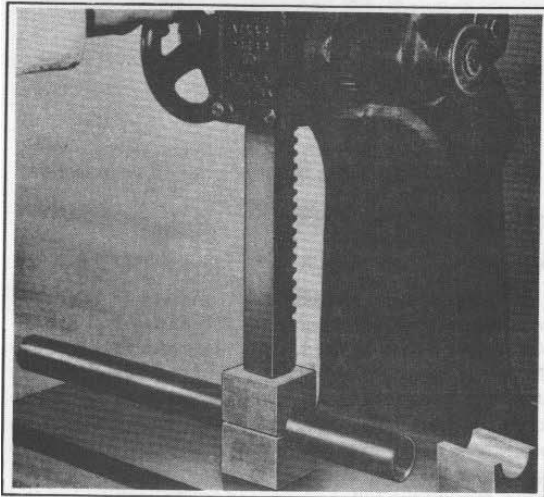

Figure 2-48. Pressing Fork Tube Round

STRAIGHTENING FORK STEM AND BRACKET ASSEMBLY

Straightening a fork stem and bracket assembly requires a great deal of skill, experience and several tools and fixtures. Special tools necessary include Fork Tube Straightening blocks, Part No. 96246-50, four blocks are needed; Bending Bar, Part No. 96806-40; Fork Stem and Bracket Aligning Gauge, Part No. 96245-51. In addition, the following pieces of bar stock are needed: Two bars, 1-5/8 in. diameter, about 12 in. long; two bars 1 in. x 4 in. x 12 in. (approximately); assorted pieces of rectangular bar stock to use in transmitting arbor press pressure to unit to be straightened.

To straighten stem and bracket, proceed as follows:

1. Insert the two 1-5/8 in. x 12 in. bars in fork bracket and secure with two clamping studs. Sometimes the bracket is so badly bent that the bars cannot be inserted. In this case, press the bars into place with an arbor press, then press on the front edge of bracket to correct the "bow" distortion as shown in Figure 2-49.
2. A bracket assembly is usually out of alignment along the horizontal centerline, with one or both legs bent.

NOTE

Reference to vertical and horizontal centerlines applies to bracket and fork stem as positioned on arbor press (see Figure 2-49).

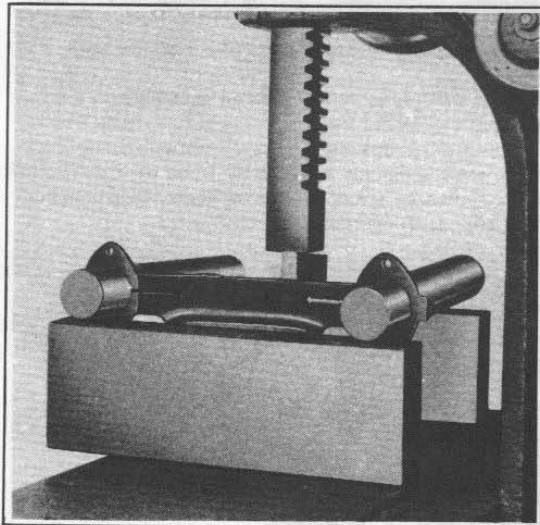

Figure 2-49. Correcting Bracket Bow

If both legs are twisted, place bracket assembly on arbor press as shown in Figure 2-50 with blocks placed under two low legs only (A and B). With press block placed across bracket and bar assembly, press until high legs (C and D) are in alignment.

3. If one leg is bent, place bracket and bar assembly on three straightening blocks, two blocks under straight leg and one block under low end of other leg. Place press block diagonally across bracket assembly to high leg until high leg is forced down and into alignment with the other three leg ends.

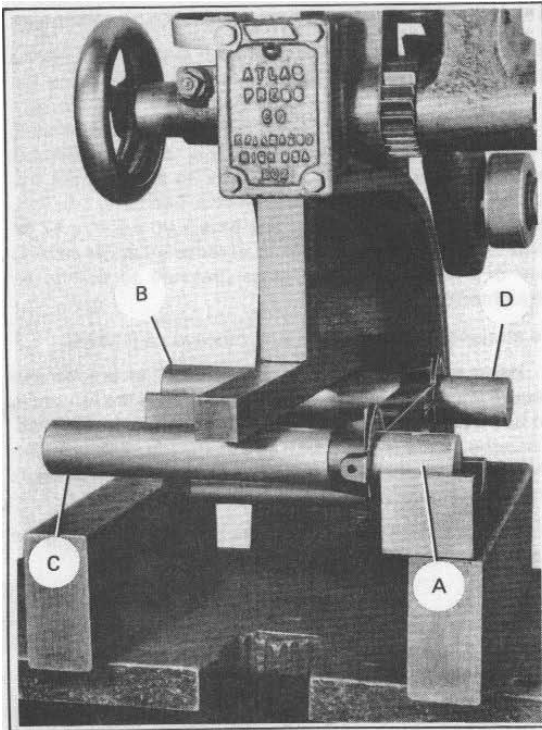

Figure 2-50. Straightening Two Twisted Legs

4. Place the fork stem and bracket assembly on the four straightening blocks located on the surface plate (see Figure 2-51). If the legs rest squarely on straightening blocks, the bracket assembly is correctly trued on a horizontal plane. If bracket is not true, press again, checking alignment after each operation.

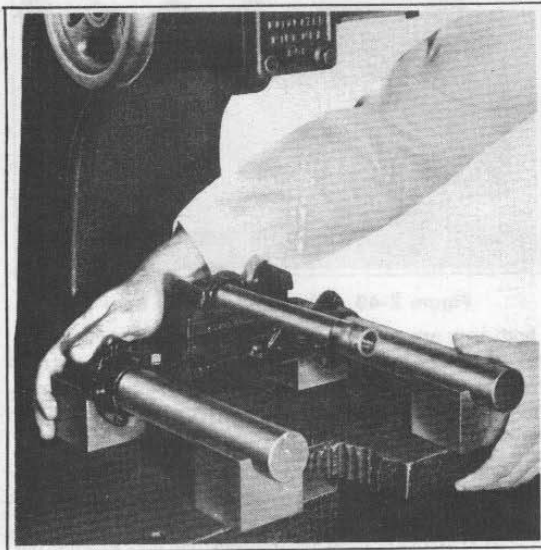

Figure 2-51. Checking Bracket Alignment

5. Use a square to check if bracket assembly is bent, distorted or out of parallel on a horizontal plane as shown in Figure 2-52. Place bracket and bar assembly in a heavy vise and straighten using the Bending Bar.

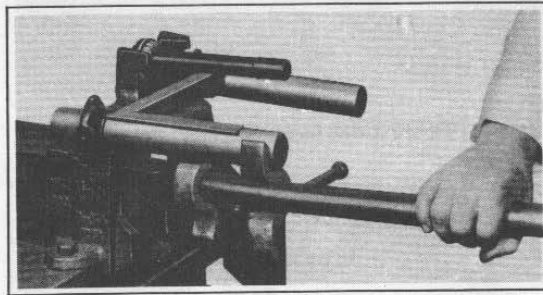

Figure 2-52. Bending Bracket Legs Parallel

6. Check fork stem alignment with Fork Stem and Bracket Aligning Gauge as shown in Figure 2-53. Use Bending Bar to bring stem into position. Recheck the fork completely.

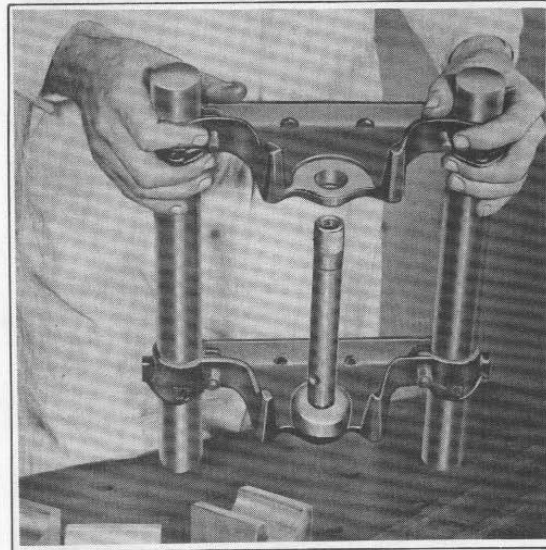

Figure 2-53. Checking Stem Alignment with Gauge

REAR SHOCK ABSORBER

ADJUSTING REAR SHOCK ABSORBER SPRING

1. The rear shock absorber springs can be adjusted to three positions for the weight the motorcycle is to carry. The average weight solo rider would use the extended spring position (off cam); when in low position (off cam), the cam lobes should be next to each other: that is, single lobes and double lobes matched. If necessary, rotate the cam to line them up properly. A heavy solo rider might require the position with springs slightly compressed (first cam step); buddy seat riders require the fully compressed spring position (second cam step).

2. To adjust the rear shock absorber springs, turn cushion spring adjusting cam to desired cam position with Spanner Wrench, Part No. 94700-52B. Both cushion spring adjusting cams must be adjusted to the same position. Always back off cam in opposite direction when releasing spring tension to intermediate or solo position.

NOTE

If shock cam is turned too far so that it falls off top position, it will not be matched correctly with other cam. To correct this condition, continue 180 degrees in same direction until it falls off again and then adjust to desired position.

DISASSEMBLING REAR SHOCK ABSORBER
(Figure 2-54)

Position motorcycle on Service Stand, Part No. 96810-63, or suitable blocking.

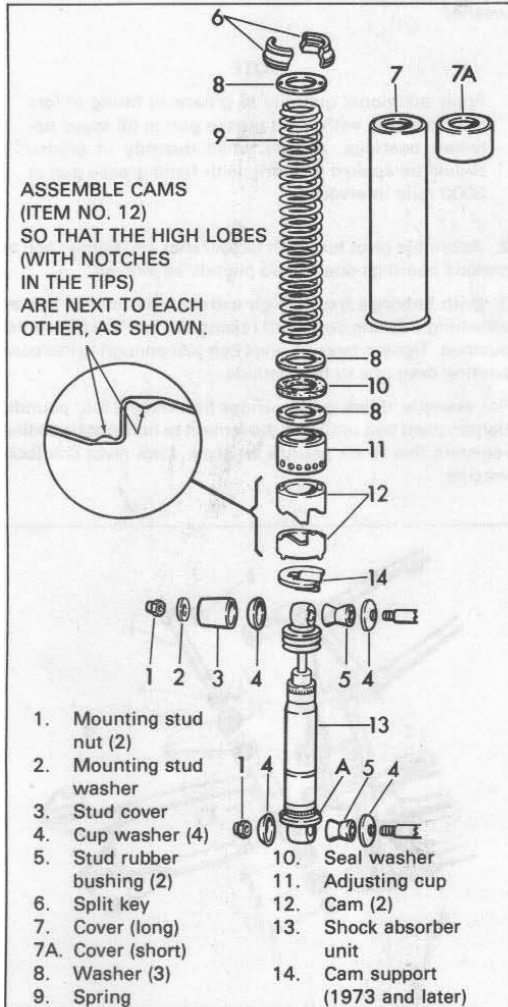

Figure 2-54. Rear Shock Absorber - Exploded View

Remove top and bottom mounting stud nut (1), mounting stud washer (2), upper stud cover (3) and cup washer (4). Slip shock absorber assembly off upper and lower studs. Push rubber bushings (5) from shock absorber mounting eyes. Place shock absorber in Rear Shock Absorber Tool, Part No. 97010-52A with split key (6) up. Compress absorber spring enough to remove each half of split key (6) from flange on shock eye as shown in Figure 2-55. Release spring compression and remove absorber assembly from tool. Remaining items can be removed in order shown in Figure 2-54.

INSPECTING

1. Examine absorber unit for traces of fluid leaking, especially at upper end. Unit should have no leaks and should compress slightly easier than it extends. If possible, compare action with unused unit. Shock absorbers cannot be repaired. Faulty units must be replaced.

2. Clean and examine all other parts for wear and damage, paying particular attention to the condition of the stud rubbers, the ride control adjustment cams, dirt seal and spring.

ASSEMBLING REAR SHOCK ABSORBER

Rear shock absorber assembly is essentially the reverse of disassembly.

Apply a thin coat of grease to all surfaces of both cams. Note that cams (12) are identical and be sure to position cam lobes correctly as shown in Figure 2-54 inset. Place assembly in compressor tool and compress spring enough to install key halves (6). Release spring compression. Keys will lock into place in inside diameter of covers 7 or 7A.

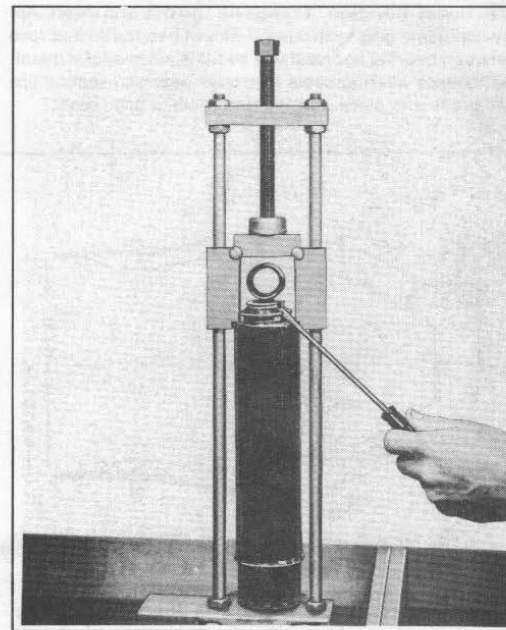

Figure 2-55. Disassembling Shock Absorber

IMPORTANT

Install each shock absorber on motorcycle with slot in cam support (A, Figure 2-54) facing toward wheel.

REAR FORK

DISASSEMBLING REAR FORK (Figure 2-56)

To disassemble rear fork, first remove following assemblies:

1. Rear wheel (see "Wheels").
2. Rear brake side cover with connecting control linkage (see "Brakes").
3. Rear shock absorbers (see "Shock Absorbers").
4. See Figure 2-56. Turn back locking ear on pivot bolt lockwasher (2) and turn out pivot bolt (1). Remove fork (3) from frame. With appropriate size arbor pin, push out bearing spacer (4), bearing seal (5) and bearing with outer race (6) from each side of fork pivot bearing.

INSPECTING AND SERVICING

1. Clean pivot bolt hole in fork and bearing parts. Check for wear of bearing, bearing race and bearing seal.
2. Rough check the rear fork for correct alignment. Dimensions shown in Figure 2-56 will provide enough information to determine if fork is far enough out of alignment to require realigning or replacement. Straightening a badly bent fork requires special tools and fixtures for holding, bending and gauging.

ASSEMBLING REAR FORK

1. Press outer bearing races into fork. Grease bearings with Harley-Davidson "Grease-All" grease and insert. Apply additional grease to outside face of bearing so that race between bearing and seal will be filled when seal is installed. Grease bearing seals in groove between sealing lips and press into place. Put bearing spacers over seals.

NOTE

Apply additional quantity of grease to fitting in fork pivot housing with hand grease gun to fill space between bearings. A very small quantity of grease should be applied to fitting with hand grease gun at 2500 mile intervals.

2. Assemble pivot bolt with lockwasher and tighten bolt to preload bearings one to two pounds as follows:
3. With bearings free, weigh extreme rear end of fork by attaching a spring scale and raising the fork to a horizontal position. Tighten bearing pivot bolt just enough to increase bearing drag one to two pounds.

For example, if fork with bearings free weighs four pounds, tighten pivot bolt until fork movement to horizontal position registers five to six pounds on scale. Lock pivot bolt lockwasher.

NOTE

Apply additional quantity of grease to fitting in fork pivot housing with hand grease gun to fill space between bearings. A very small quantity of grease should be applied to fitting with hand grease gun at 2000 mile intervals.

2. Assemble pivot bolt with lockwasher and tighten bolt to preload bearings one to two pounds as follows:
3. With bearings free, weigh extreme rear end of fork by attaching a spring scale and raising the fork to a horizontal position. Tighten bearing pivot bolt just enough to increase bearing drag one to two pounds.

For example, if fork with bearings free weighs four pounds, tighten pivot bolt until fork movement to horizontal position registers five to six pounds on scale. Lock pivot bolt lockwasher.

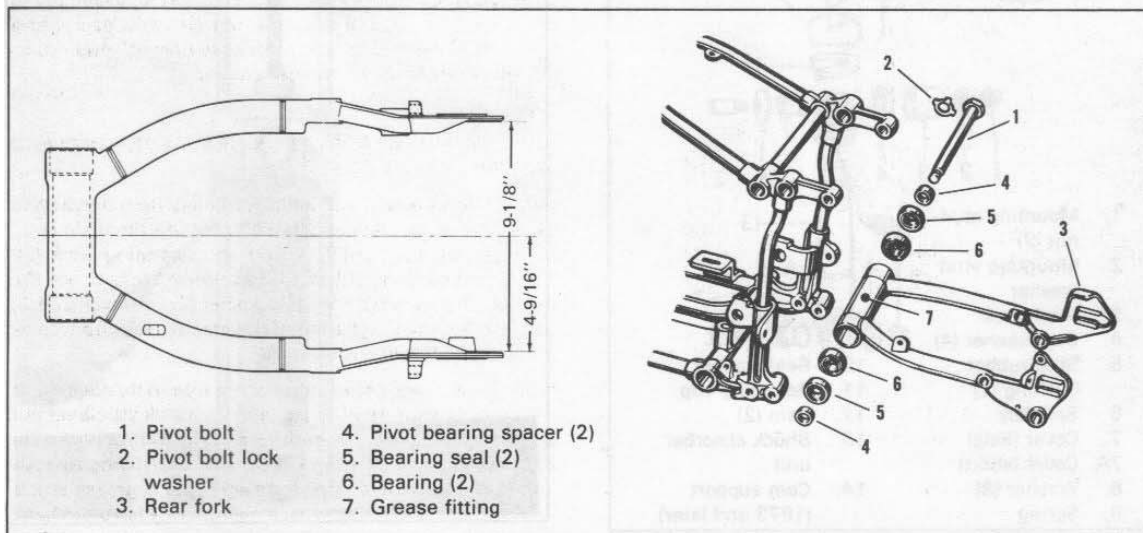

Figure 2-56. Rear Fork - Exploded View

BRAKES

GENERAL

The front wheel brake is operated by a hand lever on right handlebar, and the rear wheel brake is operated by a foot pedal on the right side of the motorcycle. To keep drum type brakes in proper operating condition, it is essential to check adjustment of brakes at regular service intervals of 5000 miles, or sooner, depending on wear of brake linings and drums. See adjustment of brakes and centering brake shoes. If brakes do not operate satisfactorily after adjustment of linkage and recentering brake shoes in drums, disassemble and service brakes and connecting linkage. Hydraulic disk brakes are self-adjusting. Brake fluid level in both front and rear brake master cylinders should be checked every 1000 miles.

FRONT MECHANICAL DRUM BRAKE

ADJUSTING FRONT BRAKE SHOES - FL, FX

Raise front wheel off ground so it may be rotated. Loosen brake shoe pivot stud nut (5, Figure 2-57) and loosen axle sleeve nut. Apply brake. With brake pressure applied, tighten axle sleeve nut and pivot stud nut. This procedure centers shoes against drum so full lining length contacts drum on brake application.

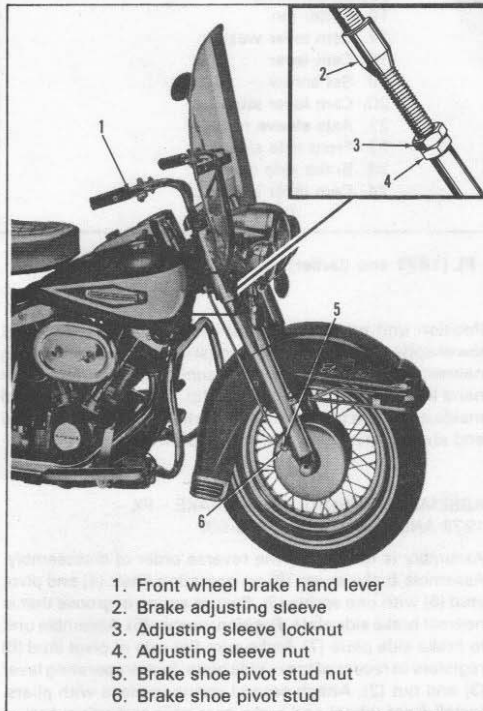

Figure 2-57. Adjusting Front Brakes - Drum Type

ADJUSTING FRONT BRAKE CABLE - FL, FX (Figure 2-57)

Front brake cable may be adjusted as follows:

Loosen adjusting sleeve locknut (3) and turn adjusting sleeve nut (4) to obtain desired amount of hand lever (1) free movement; clockwise for less movement and counter-clockwise for more movement. About 3/16 in. of brake cable movement should be free, or about 1/4 of the full lever movement. Tighten adjusting sleeve locknut.

DISASSEMBLING FRONT BRAKE - FL - 1971 AND EARLIER (Figure 2-59)

Remove wheel with brake drum from fork as described in "Wheels." Spring brake shoes out and away from side cover (23) at top to free shoes (2 and 4) and springs (1 and 3) from pivot stud (8) and cam lever (18).

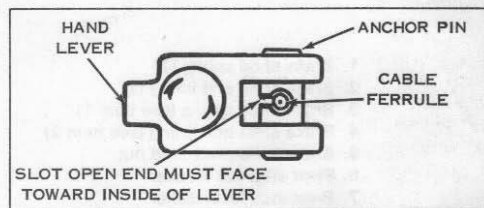

Figure 2-58. Correct Handlebar Control Cable Assembly

Remove cotter pin (16), cam lever washer (17) from cam lever stud (20). Disconnect cable ferrule from anchor pin in hand lever by loosening clamp nut (10) and depressing brake hand lever. Slip cam lever assembly off stud. Make complete disassembly in order shown.

DISASSEMBLING FRONT DRUM BRAKE - FX - 1972 AND EARLIER (Figure 2-60)

Remove front wheel and brake assembly from motorcycle as described in "Removing and Installing Front Wheel." Remove operating shaft nut (2) and operating lever (3). Lightly tap operating shaft (4) to remove brake shoes (8), springs (9), operating shaft (4), washer (5) and pivot stud (6) as a unit from brake side plate (7). Remove shoes from operating shaft (4) and pivot stud (6).

If the front wheel brake cable is not free in its housing, is frayed or broken, replace cable. Remove clevis clamp nut and clamp. Free cable from clevis and pull from upper end of coil. Install new cable from upper end of housing as positioned on motorcycle, applying a light coat of grease as it is inserted into coil. When reassembling cable ferrule in hand lever anchor pin with side slot, be sure slot is toward inside as shown in Figure 2-58.

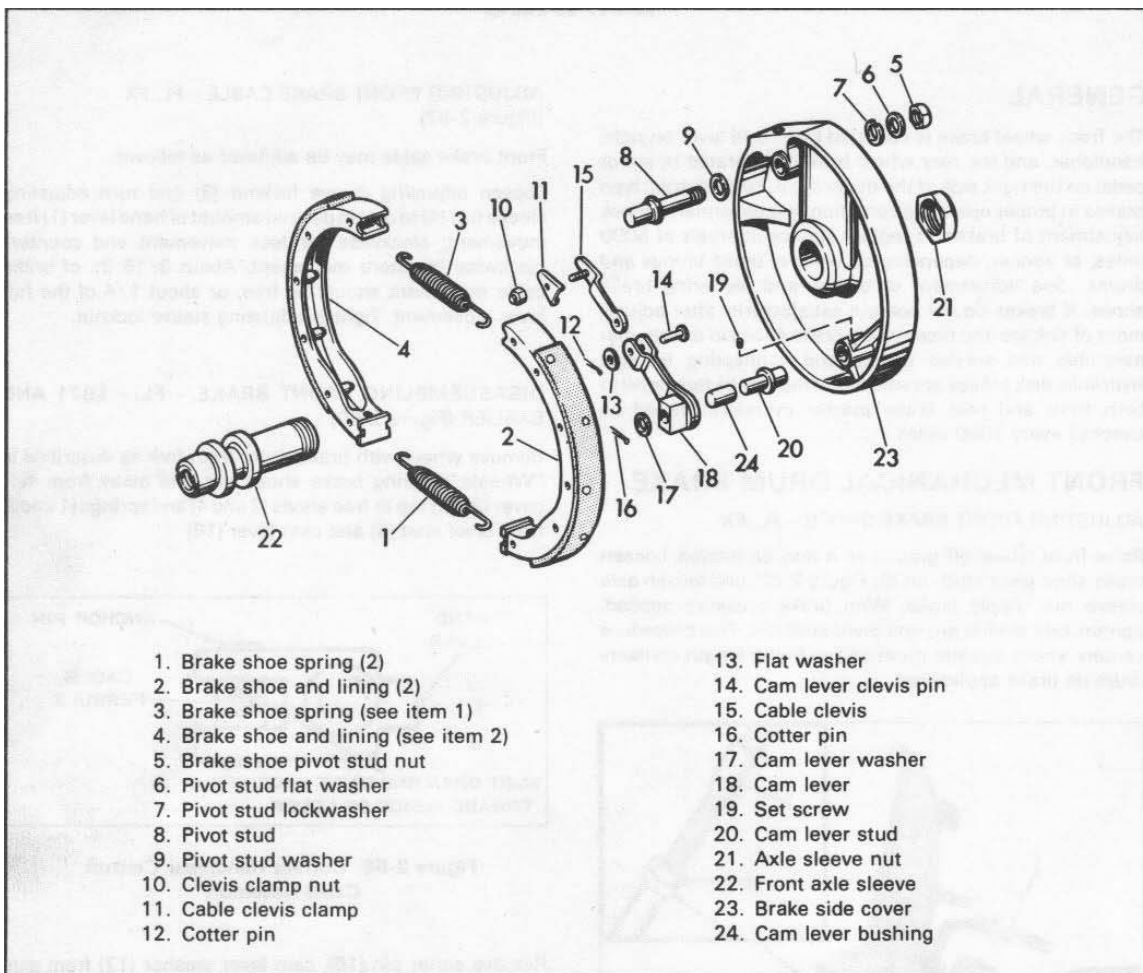

Figure 2-59. Front Brake - FL (1971 and Earlier)

INSPECTING AND SERVICING

If linings are worn down to rivet heads, impregnated with grease as a result of over-greasing wheel hubs, cracked or ridged badly, they must be replaced. When relining a shoe, start at one end and work to the other to make linings bear tightly against shoe. If a riveting machine is not available, set rivets with hand tools and bevel lining ends.

Examine drums for ridging and scoring. Surface must be reasonably smooth and flat. If ridged, turn down drums to clean up. Wash cam lever and cam lever stud and check fit. If play exists on FL, force out cam lever bushing (24) and install new part.

ASSEMBLING FRONT DRUM BRAKE - FL - 1971 AND EARLIER (Figure 2-59)

Assemble in reverse order of disassembly except, for ease of assembly, connect two shoes with top return spring (3).

Position unit on pivot stud (8) and cam lever (18). Insert lower spring (1). Spring hooks must be in shoe spacer notch nearest side cover. When reassembling cable ferrule in hand lever anchor pin with side slot, be sure slot is toward inside as shown in Figure 2-58. Earlier type pin with slotted end should have open end facing downward.

ASSEMBLING FRONT DRUM BRAKE - FX - 1972 AND EARLIER (Figure 2-60)

Assembly is essentially the reverse order of disassembly. Assemble brake shoes (8) on operating shaft (4) and pivot stud (6) with one spring (9). Secure spring in groove that is nearest brake side plate. Position washer (5). Assemble unit to brake side plate (7). Make sure flat side of pivot stud (6) registers in recess of brake side plate. Install operating lever (3) and nut (2). Attach second spring in place with pliers. Install front wheel and brake assembly and adjust brakes and center brake shoes.

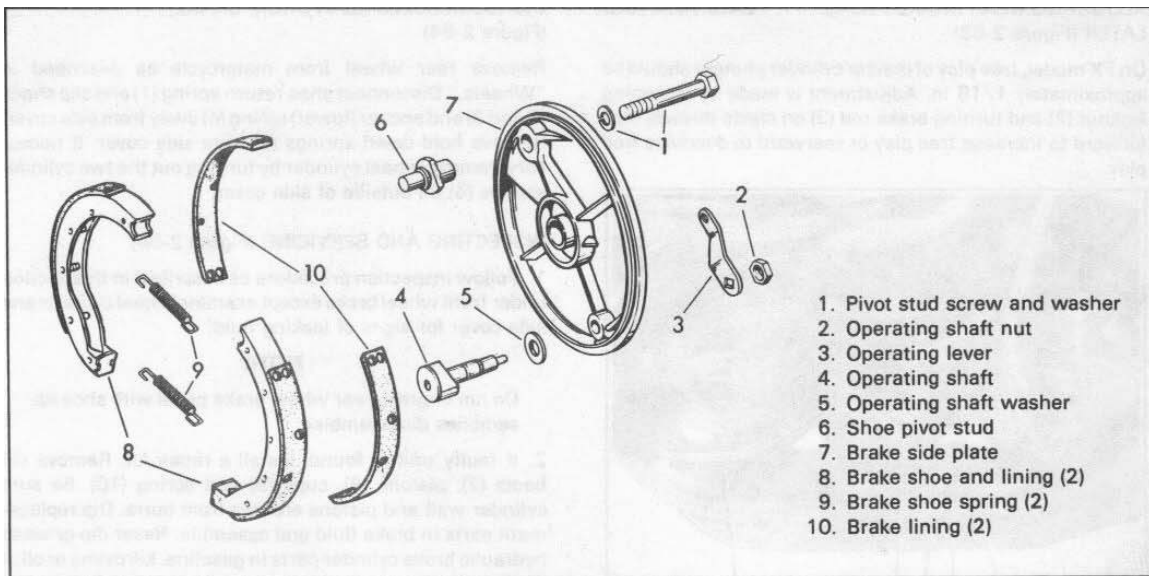

Figure 2-60. Front Brake - FX (1972 and Earlier)

REAR HYDRAULIC DRUM BRAKE

ADJUSTING REAR BRAKE SHOES (Figure 2-61)

Raise rear wheel so it can be turned freely by hand. Brakes are adjusted by means of two adjusting cams located on outside of brake side cover. Turn front adjusting cam nut (1) counterclockwise until wheel has noticeable drag. Spin wheel forward and backward to center shoes. Slowly turn cam nut clockwise until wheel turns freely. Repeat process on rear cam nut (2) which spreads shoes with a clockwise rotation and retracts shoes with a counterclockwise rotation.

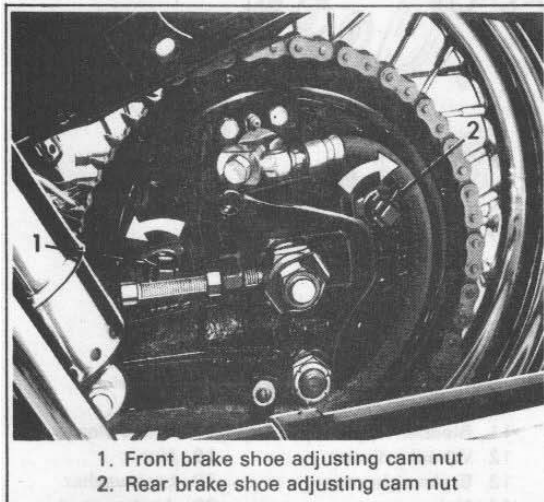

Figure 2-61. Adjusting Rear Brake (1972 and Earlier)

ADJUSTING REAR BRAKE PEDAL - FL (Figure 2-62)

Work brake pedal (1) back and forth by hand to determine free play before push rod contacts piston in master cylinder. Free play of push rod should be approximately 1/16 in. Adjustment is made by loosening master cylinder rear bolt (4) and brake pedal stop plate bolt (2). Move front end of plate (3) down to decrease free play, or up to increase free play.

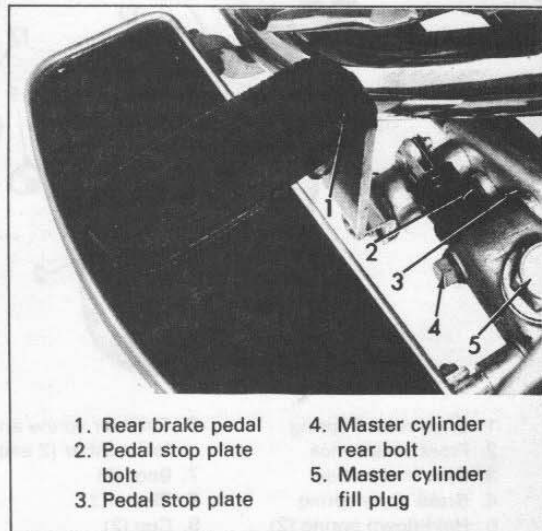
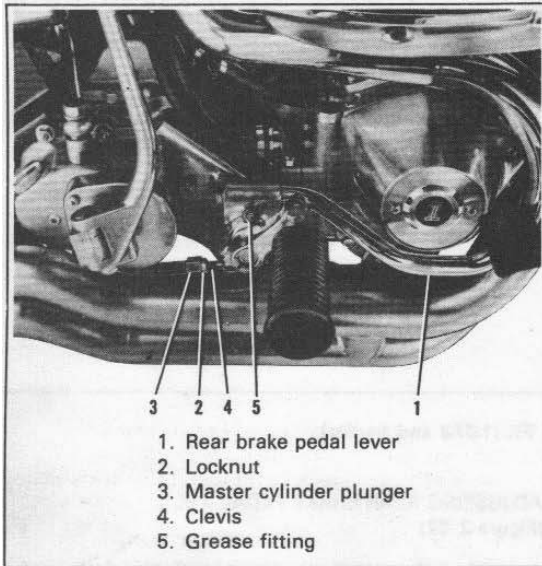

Figure 2-62. Adjusting Rear Brake Pedal - FL

ADJUSTING REAR BRAKE PEDAL - FX - LATE 1972 AND LATER (Figure 2-63)

On FX model, free play of master cylinder plunger should be approximately 1/16 in. Adjustment is made by loosening locknut (2) and turning brake rod (3) on clevis threads (4) - forward to increase free play or rearward to decrease free play.



1. Rear brake pedal lever
2. Locknut
3. Master cylinder plunger
4. Clevis
5. Grease fitting

Figure 2-63. Adjusting Rear Brake Pedal - FX (Late 1972 and Later)

DISASSEMBLING REAR DRUM BRAKE (Figure 2-64)

Remove rear wheel from motorcycle as described in "Wheels." Disconnect shoe return spring (1) and slip shoes (2 and 3) and anchor (lower) spring (4) away from side cover. Remove hold-down springs (5) from side cover. If necessary, remove wheel cylinder by turning out the two cylinder screws (6) on outside of side cover.

INSPECTING AND SERVICING (Figure 2-64)

1. Follow inspection procedure as described in this section under front wheel brake except examine wheel cylinder and side cover for signs of leaking fluid.

NOTE

Do not depress rear wheel brake pedal with shoe assemblies disassembled.

2. If faulty unit is found, install a repair kit. Remove old boots (7), pistons (8), cups (9) and spring (10). Be sure cylinder wall and pistons are free from burrs. Dip replacement parts in brake fluid and assemble. Never dip or wash hydraulic brake cylinder parts in gasoline, kerosene or oil. If necessary to clean parts use denatured alcohol.

NOTE

When linings are worn down at any point so rivet heads come close to contacting drum surface, shoes or linings should be replaced.

NOTE

Replace bonded type drum brake linings when worn down to 0.100 in. minimum thickness.

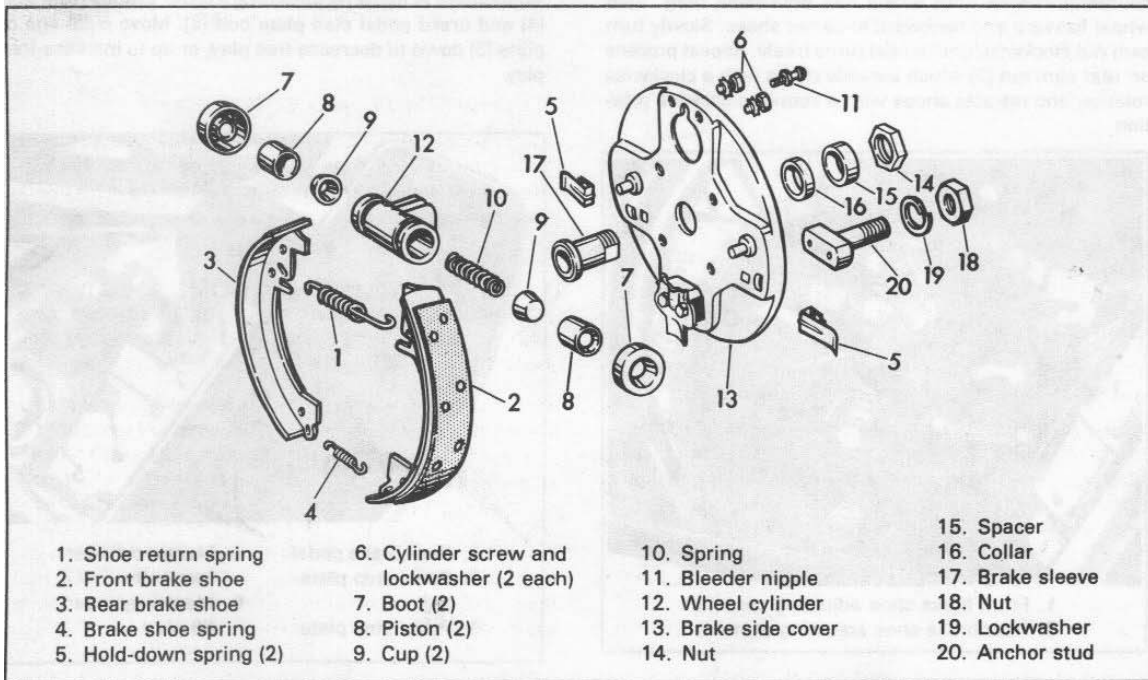

- | | | | |
|-------------------------|---|----------------------|------------------|
| 1. Shoe return spring | 6. Cylinder screw and lockwasher (2 each) | 10. Spring | 15. Spacer |
| 2. Front brake shoe | 7. Boot (2) | 11. Bleeder nipple | 16. Collar |
| 3. Rear brake shoe | 8. Piston (2) | 12. Wheel cylinder | 17. Brake sleeve |
| 4. Brake shoe spring | 9. Cup (2) | 13. Brake side cover | 18. Nut |
| 5. Hold-down spring (2) | | 14. Nut | 19. Lockwasher |
| | | | 20. Anchor stud |

Figure 2-64. Rear Drum Brake (1972 and Earlier) - Exploded View

3. Scored or grooved brake drums should be refinished before installing new shoes or linings. Brake Drum turning arbor, Part No. 97280-60A can be used to refinish brake drum inside diameter on a lathe as necessary to clean up.
4. Use standard size shoe or lining set for brake drums refinished up to 8.040 in. maximum on inside diameter.
5. Use a .030 in. oversize shoe or lining set for brake drums refinished over 8.060 in. but not more than 8.100 in. maximum on inside diameter.

ASSEMBLING REAR DRUM BRAKE (Figure 2-64)

1. Assemble rear wheel brakes in reverse order of disassembly except: Apply a light coat of grease on hold-down springs (5) and spots on side cover (13) where shoes touch when in operating position.

CAUTION — Front shoes (2) and rear shoe (3) are of different widths. Narrow shoe must be in rear position and wide shoe in front position.

2. Assemble shoes (2 and 3) to lower return spring (4), position shoe assembly on plate anchor block at bottom of side cover and install top spring (1). Short hook is inserted in elongated hole on front shoe. Reassemble wheel.

SIDECAR WHEEL DRUM BRAKE

1. Remove wheel with brake drum as described in "Wheels."
2. Procedure for servicing sidecar wheel brake is the same as for rear wheel brake as given in preceding paragraphs.

DISC BRAKE

OPERATION

NOTE

Two types of calipers are used. The following description applies to Figure 2-65. Brakes shown in Figures 2-65 and 2-66 operate in a similar manner.

The front brake master cylinder is an integral part of the brake hand lever assembly on the right handlebar. The rear brake master cylinder is located on right side of motorcycle and is operated by a foot pedal. A hydraulic hose connects the master cylinder to the brake cylinder located in the outer caliper half. Brake pads in the caliper halves apply pressure to each side of disc mounted on the wheel hub.

When the brake lever is operated, the hydraulic fluid forces the piston against the brake pads which contact the disc. The wave spring is compressed between the backing plate (6) and the adjusting ring. The press-fit adjusting ring (7) moves as necessary, to take up excess clearance as friction material wears away. The press-fit adjusting ring takes up a new position in the cylinder and is now located correctly to maintain running clearance when brake is released and makes brake self-adjusting. The action of the wave spring pulls the brake piston away from the disc to create a small pad-to-disc running clearance. Late 1974 and later front calipers do not have a wave spring. Retraction is accomplished by the piston O-ring.

Every 1000 miles, check the rear master cylinder plunger to see that it has 1/16 in. free play.

CHECK LIST

When the disc brake is not operating properly use the following list for possible causes.

1. Excessive hand lever or pedal travel or spongy feel.
 - Air in system – bleed brake.
 - Master cylinder low on fluid – fill master cylinder with approved brake fluid.
2. Chattering or scraping sound when brake is applied.
 - Worn or defective pads – replace brake pads.
 - Loose mounting bolts – tighten bolts.
 - Warped disc – replace disc.
3. Ineffective brake – lever or pedal travels to the limit.
 - Low fluid level – fill master cylinder with D.O.T. 5 brake fluid.
 - Piston seal defective – replace piston cup O-ring in brake piston.
 - Brake dragging fades due to heat.
4. Ineffective brake – lever or pedal travel normal.
 - Distorted disc – replace brake disc.
 - Distorted or contaminated brake pads – replace brake pads.
5. Brake pads drag on disc – will not retract.
 - Piston binding in adjusting ring – replace brake piston and adjusting ring.
 - Piston in master cylinder not uncovering relief port – check master cylinder.
 - Rear brake pedal linkage out of adjustment – readjust.

REAR BRAKE PEDAL ADJUSTMENT

Rear brake pedal on FL and FX models must be adjusted so that master cylinder push rod has approximately 1/16 in. free play. Follow procedure described in "Rear Hydraulic Brake" section.

DISASSEMBLING DISC BRAKE CALIPERS – 1972 AND LATER FL/FLH FRONT AND REAR, 1973 FX FRONT AND REAR, 1974 AND LATER FX/FXE/FXS REAR ONLY (Figure 2-65)

If only the caliper assembly is to be removed, it is not necessary to remove the wheel. To remove the caliper assembly proceed as follows: Remove hose clamp. Remove 4 bolts (1) and washers (2). Remove outer caliper half (3) and damper spring (3A). Remove mounting pin (4) and inner caliper half (5). Remove brake pad mounting pins (6) and brake pads (7). Check the friction pads for wear, damage, and looseness. Replace both pads if thickness of friction material is less than 1/16 in. Check to see that the metal backing plate is flat. If it is at all bowed replace the brake pad.

NOTE

Brake pads should only be replaced as a set.

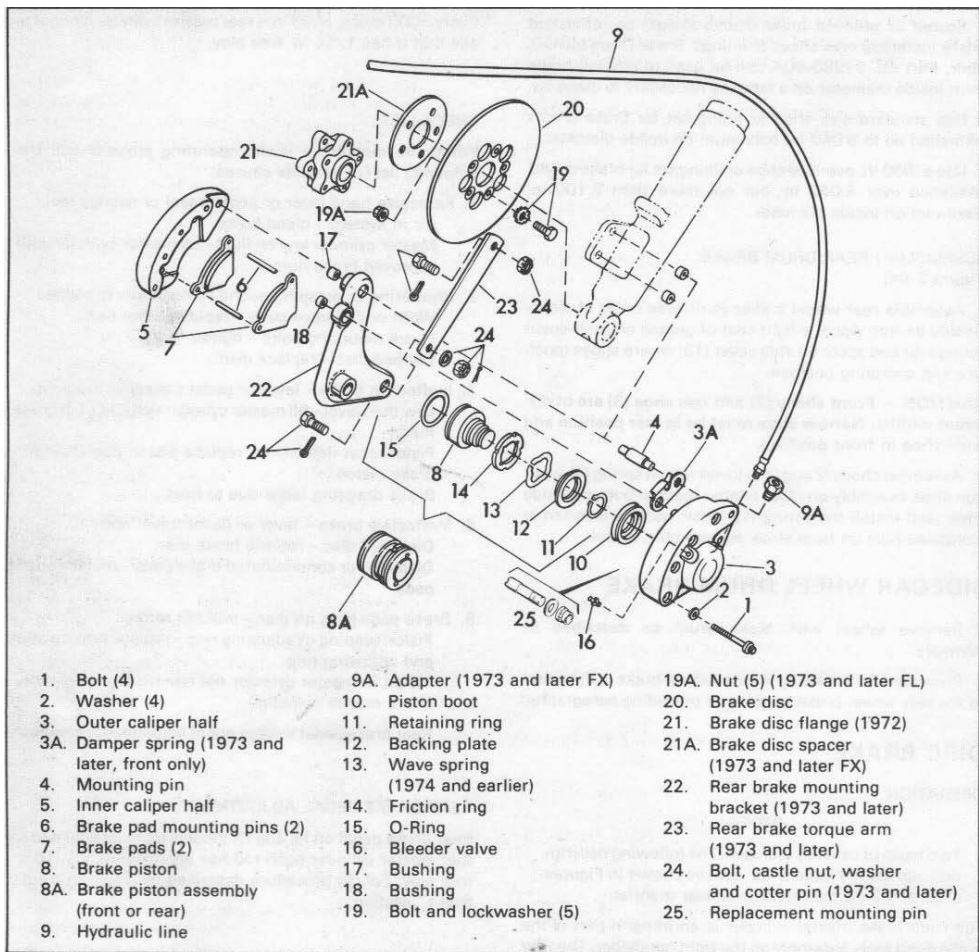

Figure 2-65. Disc Brake - Exploded View, 1972 and Later FL/FLH Front and Rear, 1973 FX Front and Rear, 1974 FX/FXE/FXS Rear Only

With hydraulic system connected to outer caliper half assembly (3), use a dial indicator to check piston retraction. Mount dial indicator on back of outer caliper with indicator plunger on the piston face. Apply brake. Set dial indicator on zero. Release brake. Front brake piston (stamped "F") should retract .020 to .025 in. Rear brake piston (stamped "R") should retract .033 to .038 in. If it does not, replace piston assembly (8A). Do not remove piston assembly unless there are signs of hydraulic fluid leakage or if piston is not operating properly.

To remove piston (8 or 8A), pump brake hand lever until piston will move no farther. Remove hydraulic line (9). Push piston boot (10) back from groove in piston and pull piston the rest of the way out.

Remove the retaining ring (11, if used) using external retaining ring pliers, Harley-Davidson Part No. 95017-61. Backing plate (12), wave spring (13), adjusting ring (14), and O-ring (15) may now be removed. Remove bleeder valve (16). Clean all parts in solvent and inspect. Replace any parts that are worn, or damaged. Inspect cylinder bore. If it is badly scored replace outer caliper half (3). When reassembling use new O-ring (15) and adjusting ring (14).

Inspect the brake disc (20). If it is warped, or badly scored it must be replaced. If disc is worn excessively, it must be replaced. See "Removing and Installing Brake Disc." Minimum brake disc thickness is stamped on side of disc.

Clean and inspect bushings (17) and (18) in fork slider or caliper mounting bracket. Install new bushings if worn or damaged. Coat inside of bushings with Harley-Davidson "Anti-Seize" before installing caliper.

Riveted type mounting pin can be replaced with threaded type (25) if loose or damaged.

REASSEMBLING DISC BRAKE CALIPERS - 1972 AND LATER FL/FLH FRONT AND REAR, 1973 FX FRONT AND REAR, 1974 AND LATER FX/FXE/FXS REAR ONLY (Figure 2-65)

Reassembly is basically the reverse of disassembly. Make sure all parts are clean and in good condition before assembly. Dip the piston assembly (items 8 or 8A, 11, 12, 13, 14 and 15) and piston boot (10) in hydraulic fluid.

Assemble piston boot to caliper bore. Piston boot has a small hole in it to allow drainage of accumulated moisture. Assemble boot so that hole will point downward when caliper is assembled to motorcycle. Press piston assembly into caliper bore keeping it square to avoid scoring the bore. Push it firmly all the way in.

CAUTION — Be careful not to get brake fluid on brake light switch contacts. If brake fluid contaminates contacts, switch failure may occur.

NOTE

Piston assembly must be pressed all the way into the bore when new brake pads have been installed to assure proper clearance when calipers are reassembled to motorcycle.

For best braking efficiency, brake disc on wheel must be parallel with brake pads in caliper assembly. This is achieved by bending bracket (22), which mounts caliper assembly, until it aligns properly with disc.

Insert Alignment Gauge, Part No. 97168-77 into holes in bracket (22). Check to see that all three gauge pins either touch or are within 1/16 in. of surface of brake disc (20). If one or more pins do not fall within these limits, note which ones and remove gauge. Insert Bending Tool, Part No. 97169-77, into bracket holes. Using tool, bend bracket until all three gauge pins either touch or are within 1/16 in. of surface of brake disc (20).

Install bleeder valve (16). Apply "Anti-Seize" to 4 bolts (1) before assembly. Assemble caliper unit to fork side. Tighten 4 bolts (1) to 35 ft-lbs torque. Coat threads with Harley-Davidson "Pipe Sealant with Teflon" and connect hydraulic line (9). Assemble hose clamp to front fender or rear fork. Fill master cylinder reservoir with hydraulic brake fluid. Use only D.O.T. 5 hydraulic brake fluid which is approved for use in hydraulic brake systems. On front brake master cylinder fill to gasket surface.

NOTE

Turn handlebar to the left so that top of reservoir is level. Check for leaks. If leaks persist at hydraulic fittings, coat surfaces with Harley-Davidson "Pipe Sealant with Teflon." Bleed brake to purge system of air. See "Bleeding Hydraulic System." If after a short period of operation brake feels spongy, repeat bleeding procedure.

DISASSEMBLING FRONT DISC BRAKE CALIPER - 1974 TO 1977 FX/FXE (Fig. 2-66)

If only the caliper assembly is to be removed, it is not necessary to remove the wheel. To remove caliper assembly, proceed as follows: remove socket head screw (1), locknuts (2), and washers (3). Pull outer caliper half (4) and inner caliper half (5) apart. Remove pressure plate (6) with brake pad (7) attached. Check brake pads for wear, damage and looseness. Replace pads if worn down to indicator groove on bottom of pad. If pads need replacing, drill out rivets (8) with a 9/64 in. drill. Replace pads as a set only. Check to see that pressure plate (6) is flat. If it is at all bowed, replace it. Rivet new pads in place using a hollow rivet set. Before reassembling caliper halves push piston all the way into caliper bore. Also make sure that bushings in torque arm (9) are free of dirt and corrosion.

Do not remove piston from outer caliper half unless there are signs of hydraulic fluid leakage, or if piston is not operating properly.

To remove piston (10) disconnect and plug hydraulic hose (11). Pull off rubber boot (12). Using two screw drivers, carefully pry piston (10) from caliper bore. If friction ring (13) is damaged remove it from piston and replace it. Remove O-ring (14) from caliper bore. Remove bleeder valve cap (15) and bleeder valve (16). Clean all parts in solvent and inspect. Replace all parts that are worn or damaged. Inspect cylinder bore. If it is badly scored, replace outer caliper half. At this time check brake disc (17) for wear and damage. Replace brake disc if it is worn to .188 in. or less or if it is badly scored or warped. See "Wheels."

REASSEMBLING FRONT DISC BRAKE CALIPER - 1974 TO 1977 FX/FXE (Figure 2-66)

Reassembly is basically the reverse of disassembly with the following exceptions. Make sure all parts are clean and in good condition. Lubricate piston, friction ring, and O-ring with brake fluid. When assembling piston and friction ring assembly to caliper half and O-ring assembly, make sure piston is square with the bore. Tap it in place with a soft hammer while rotating it so that O-ring is not damaged. When assembling boot make sure both lips engage their respective grooves.

Make sure bosses on torque arm are clean and free from corrosion before mounting caliper. When mounting caliper halves, tighten socket head bolts to 130 in-lbs torque. Make sure caliper floats freely on torque arm.

Torque five brake disc mounting screws (18) to 10 ft-lbs torque.

Connect hydraulic line (11) to caliper. Fill front brake master cylinder with approved D.O.T. 5 hydraulic fluid. Check system for leaks and seal with Harley-Davidson "Pipe Sealant with Teflon," Part No. 99630-77 if necessary. Bleed brake to purge system of air. See "Bleeding Hydraulic System."

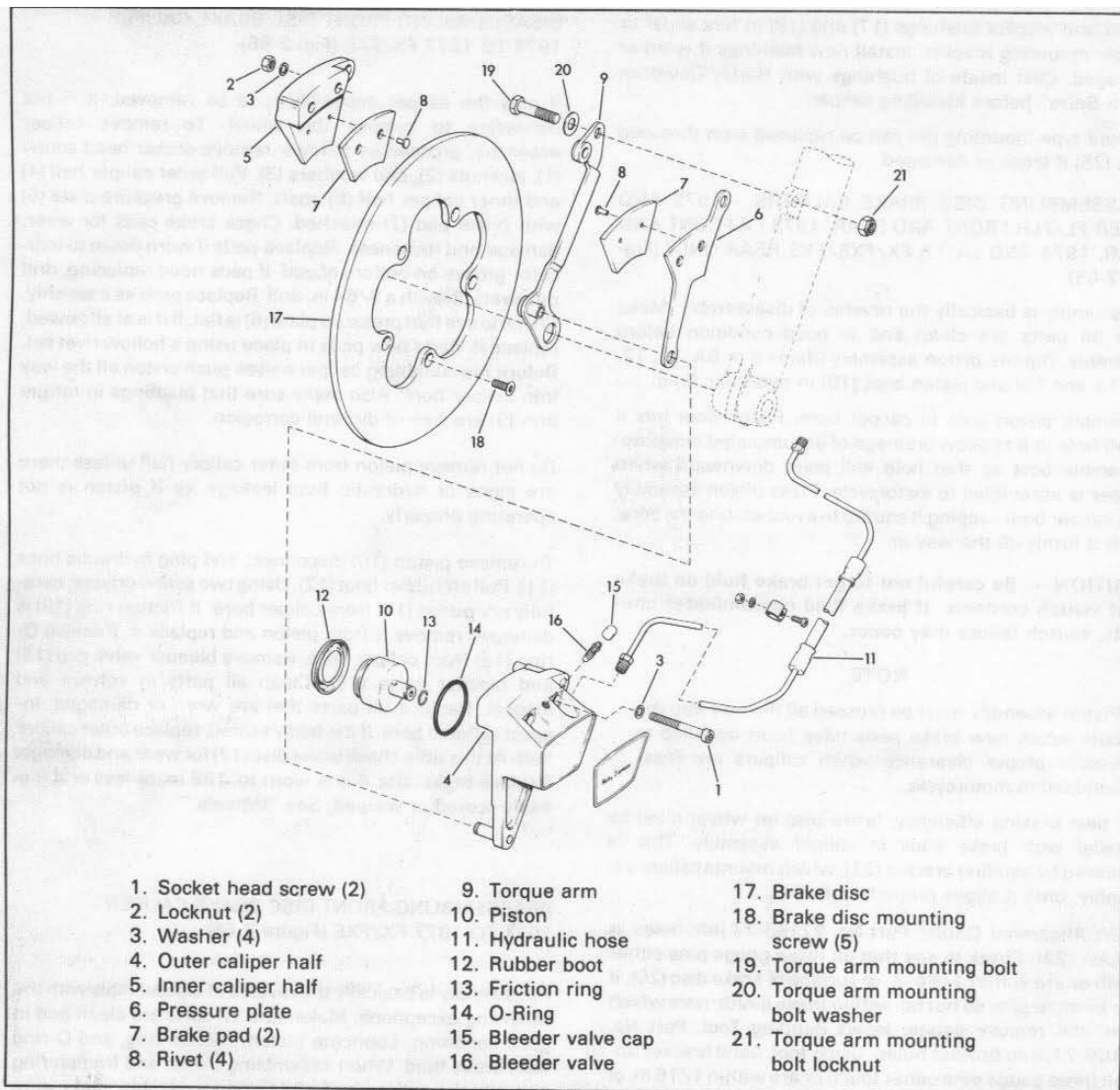

Figure 2-66. Front Disc brake, 1974 to 1977 FX/FXE

DISASSEMBLING FRONT DISC BRAKE CALIPER - 1977 & 1978 FXS, 1978 FX/FXE (Figure 2-66A)

If the brake disc must be replaced, it will be necessary to remove the wheel. See "Wheel" section. To remove and disassemble one caliper assembly, use the following procedure.

Remove the two mounting screws (1) and nuts (2) to release caliper assembly from front fork. Turn handlebar until top of master cylinder is nearly level. Remove cover and gasket. Disconnect hydraulic fitting at brake caliper and hose line. Be careful brake hose seat (3) is not lost.

Remove bolt (4) and washer (5) to disassemble caliper halves. Remove seal (6), piston boot (7), piston (8) outer plate (9), brake pad set (10) and inner plate (11) from pins (12). Pull pins from inner caliper (13) for complete disassembly.

INSPECTION AND CLEANING

If brake pads are worn to 1/16 in. or less, replace set (10). Clean all metal parts in a non-flammable cleaning solvent. Blow dry with compressed air. Rubber parts must be cleaned in denatured alcohol or brake fluid.

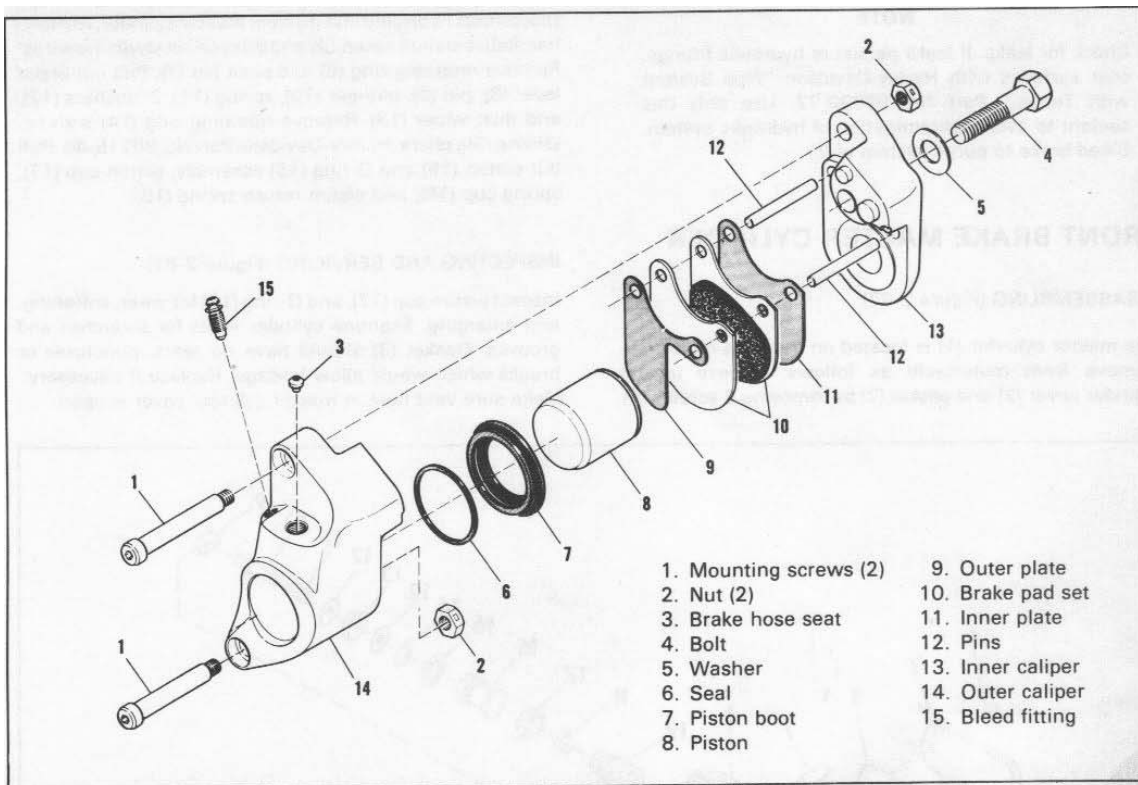

Figure 2-66A. Front Brake Caliper - 1977 and 1978 FXS, 1978 FX/FXE

WARNING — Always clean brake system rubber parts by washing in denatured alcohol or brake fluid. DO NOT use mineral base cleaning solvents such as gasoline or paint thinner. Use of mineral base solvents will cause deterioration of the part and would continue to deteriorate after assembly which could result in component failure.

Inspect all components carefully for excessive wear or damage. Discard old seal (6) and replace with a new one.

Inspect brake discs bolted to wheel assembly and replace if warped or badly scored. See "Wheels" for disassembly procedure.

WARNING — The front brake and the rear brake pads must be replaced in pairs only for correct and safe brake operation.

ASSEMBLING FRONT DISC BRAKE CALIPER - 1977 AND 1978 FXS, 1978 FX/FXE

Place the two pins (12) in the inner caliper (13). Slide the inner plate (11), brake pad set (10) and outer plate (9) onto the pins.

Dip the seal (6), piston boot (7) and piston (8) into brake fluid before assembly. Use silicone base D.O.T. 5 type fluid. Place the seal, boot and piston into the outer caliper (14).

NOTE

Piston assembly must be pressed all the way into the bore when new brake pads have been installed to assure proper clearance when calipers are reassembled to motorcycle.

Position the outer caliper on the pins (12) and secure to inner caliper assembly with washer (5) and bolt (4). Tighten to 45 to 50 ft-lbs torque.

Install bleed fitting (15), if removed, and brake hose seat (3) into outer caliper. Connect brake hose to caliper. Install front wheel, if removed. See "Wheels."

Mount the caliper assembly to the front fork with two mounting screws (1) and locknuts (2). Torque screws to 115 to 120 in-lbs.

NOTE

New locknuts should be used as this type of nut tends to lose its holding power when reused. If new locknuts are not available, "Lock and Seal," Part No. 99625-77 should be used on threads.

Turn handlebar until top of master cylinder is nearly level. Slowly fill reservoir with D.O.T. 5 type hydraulic brake fluid, to gasket level. Reservoir may be filled with pressurized equipment, see "Bleeding Hydraulic System."

NOTE

Check for leaks. If leaks persist at hydraulic fittings, coat surfaces with Harley-Davidson "Pipe Sealant with Teflon," Part No. 99630-77. Use only this sealant to avoid contamination of hydraulic system. Bleed brake to purge system of air.

Disconnect hydraulic line (5) from master cylinder. Remove handlebar switch assembly and disconnect stoplamp wires. Remove retaining ring (6) and pivot pin (7). Pull out brake lever (8), pin (9), plunger (10), spring (11), 2 washers (12), and dust wiper (13). Remove retaining ring (14) with retaining ring pliers, Harley-Davidson Part No. 96215-49. Pull out piston (15) and O-ring (16) assembly, piston cup (17), spring cup (18), and piston return spring (19).

FRONT BRAKE MASTER CYLINDER

DISASSEMBLING (Figure 2-67)

The master cylinder (1) is located on the right handlebar. Remove from motorcycle as follows: remove master cylinder cover (2) and gasket (3) by removing 2 screws (4).

INSPECTING AND SERVICING (Figure 2-67)

Inspect piston cup (17), and O-ring (16) for wear, softening, and enlarging. Examine cylinder walls for scratches and grooves. Gasket (3) should have no tears, punctures or breaks which would allow leakage. Replace if necessary. Make sure vent hole in master cylinder cover is open.

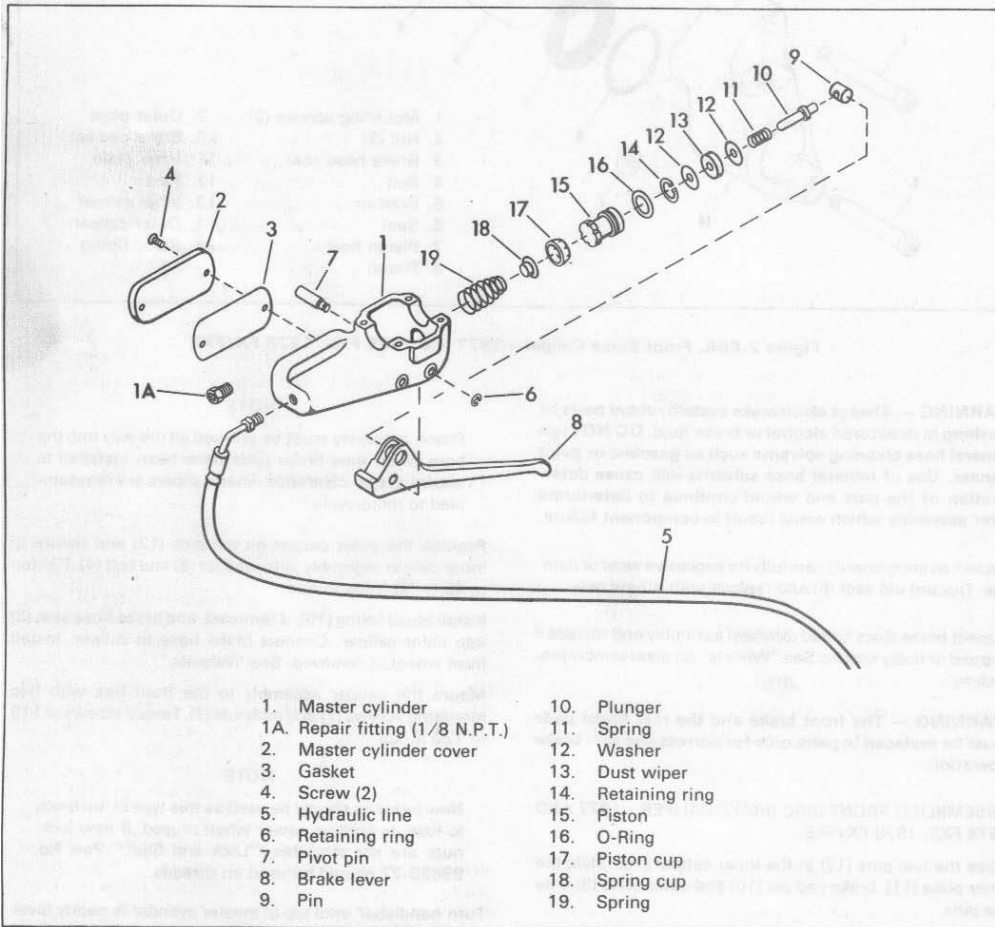

Figure 2-67. Front Disc Brake Master Cylinder, 1972 and Later FL, 1973 and Later FX/FXE/FXS - Exploded View

ASSEMBLING (Figure 2-67)

Assemble master cylinder in reverse order of disassembly. If repair kit is installed, use all new parts, not just those that look worn. Dip all internal parts in brake fluid before assembly. Lightly grease pivot pin (7) and pin (9) before assembly. Fill system with new approved hydraulic brake fluid and bleed brake system. See "Bleeding Hydraulic System." Install gasket (3) with flat side down.

IMPORTANT

Before adding hydraulic fluid, check to see that relief port in master cylinder is uncovered when brake lever is released.

Bleed system carefully to purge all air. Test ride motor-cycle. If brake feels spongy, repeat bleeding procedure.

NOTE

Hydraulic brake fluid pressure equipment can be used to fill front brake master cylinder at the bleeder fitting providing master cylinder cover is removed so that system cannot pressurize. Do not use pressure bleeding equipment when the front hydraulic system is sealed with master cylinder cover and gasket in place.

REAR BRAKE MASTER CYLINDER

DISASSEMBLING (Figure 2-68)

It is not necessary to remove master cylinder from motor-cycle to remove piston assembly if replacement is required. Remove rear brake rod clevis pin (1). Pull out plunger (4) and remove boot (5), stop wire (6), stop washer (7), piston assembly (8), cup (9), spring (10), valve (12), and valve seat (13).

NOTE

1973 and later rear brake master cylinder does not have valve (12) and valve seat (13). 1973 and later master cylinder is identified by a paint spot.

INSPECTING AND SERVICING (Figure 2-68)

Inspect cup (9) and piston rubber parts for wear, softening and enlarging. Examine cylinder walls for scratches and grooves.

ASSEMBLING (Figure 2-68)

Assemble master cylinder in reverse order of disassembly. If repair kit is installed, use all new parts, not just those that look worn. Dip all internal parts in D.O.T. 5 brake fluid before assembly. Replace fluid and bleed brake system. Adjust brake pedal as described under "Adjusting Rear Brake Pedal."

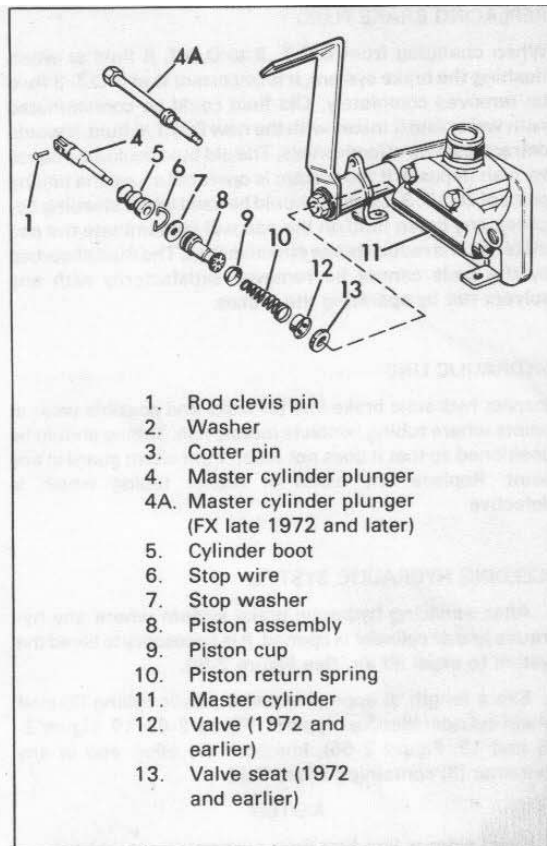

Figure 2-68. Rear Brake Master Cylinder - Exploded View

HYDRAULIC SYSTEM

BRAKE FLUID

Inspection of brake fluid level in the master cylinder reservoir should be made every 1000 miles. The master cylinder cover should be level, when removed, and fluid level should be checked without changing the position of the master cylinder. If fluid level is below the cover gasket surface or below the cap threads, fluid should be added. (A small air space is acceptable.) If D.O.T. 3 brake fluid is used, the brake system should be drained, flushed, and refilled with new brake fluid every year to eliminate any contamination such as sludge. This yearly service can be eliminated when D.O.T. 5 silicone fluid is used. We recommend you use D.O.T. 5 silicone fluid for improved performance. All motor-cycles produced since September, 1976 use D.O.T. 5 fluid.

WARNING — Brake fluid can cause irritation of eyes and skin and may be harmful if swallowed. If fluid is swallowed, induce vomiting by administering two tablespoons of salt in a glass of warm water. Call a doctor. In case of contact with skin or eyes, flush with plenty of water. Get medical attention for eyes. KEEP BRAKE FLUID OUT OF THE REACH OF CHILDREN.

REPLACING BRAKE FLUID

When changing from D.O.T. 3 to D.O.T. 5 fluid or when flushing the brake system, it is important that D.O.T. 3 fluid be removed completely. Old fluid could be contaminated with water and if mixed with the new D.O.T. 5 fluid, it would detract from its effectiveness. The old fluid could also cause varnish deposits if the system is operated above the boiling point of D.O.T. 3. Caution should be used when bleeding because any brake fluid on the pad will contaminate the pad material and reduce brake effectiveness. The fluid absorbed by the pads cannot be removed satisfactorily with any solvent nor by operating the brakes.

HYDRAULIC LINE

Inspect hydraulic brake line for leaks and possible wear at points where tubing contacts motorcycle. Tubing should be positioned so that it does not touch front chain guard at any point. Replace any metal or rubber tubing which is defective.

BLEEDING HYDRAULIC SYSTEM

1. After servicing hydraulic brake system where any hydraulic line or cylinder is opened, it is necessary to bleed the system to expel all air. See Figure 2-69.
2. Slip a length of appropriate size plastic tubing (2) over wheel cylinder bleeder nipple (1, Figure 2-69; 16, Figure 2-65 and 15, Figure 2-66). Immerse the other end in any container (3) containing brake fluid.

NOTES

Bleed sidecar line first then motorcycle rear wheel.

When bleeding front disc brake, turn handlebars to the right to position bleeder fitting as nearly vertical as possible.

When bleeding rear disc brake, it may be necessary to remove torsion arm to allow brake caliper to be rotated to bring bleeder fitting to a vertical position.

3. Open bleeder nipple by rotating counterclockwise about one-half turn. With master cylinder full of fluid at all times, slowly operate brake repeatedly until fluid flows from bleeder nipple free of air bubbles. Add fluid to master cylinder to bring to original level. Close bleeder nipple and tighten to 35 in-lbs torque. Do not reuse fluid unless it is clear and free from sediment. If it is impossible to bleed all air from system, the master cylinder check valve is faulty and a master cylinder repair kit must be installed.

IMPORTANT

Free play of rear brake plunger (4/4A, Figure 2-68) should be approximately 1/16 in. to be sure rear brake cylinder hydraulic pressure is relieved. Adjustment should be made starting with linkage excessively loose, then working toward tightening direction until the 1/16 in. free play is attained.

Front brake lever should have free play up to 1/4 in. measured at end of lever. After adjusting free play, check for pressure relief indication by removing master cylinder fill plug and watching for fluid bubble when pedal or lever is activated.

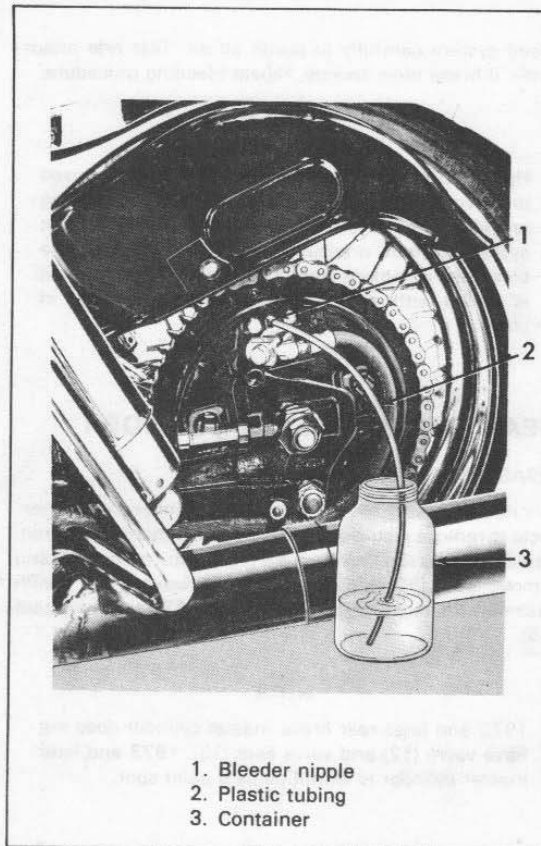

Figure 2-69. Bleeding Hydraulic Brake System

SEAT

SOLO SADDLE

SEAT POST SPRINGING

Two seat post spring arrangements are available for this model. A standard spring set is suitable for rider weighing up to 220 pounds. A heavy spring set for weights over that amount include heavier springs and longer guide collars. The heavy set is indicated by a letter "D" stamped on the upper end of the seat post plunger. See Figure 2-70 for cutaway view of seat post springing arrangement.

DISASSEMBLING SEAT POST (Figure 2-71)

Remove rod locknut (1) and washer (2) from bottom of frame seat post tube. Pull back of seat upward sharply to break loose seat post rod nut (5) at the base of the seat post tube. Unsnap clevis pin spring (3) and pull out clevis pin (4). Tip seat forward and lift out seat post assembly. Disassemble remaining parts in order indicated.

INSPECTING AND SERVICING

Wash and air dry all parts. Inspect for broken or "set" springs. New spring length appears in Figure 2-71 listing. Replace seat bar bushings (19) if worn appreciably.



Figure 2-70. Cutaway of Seat Post Springing

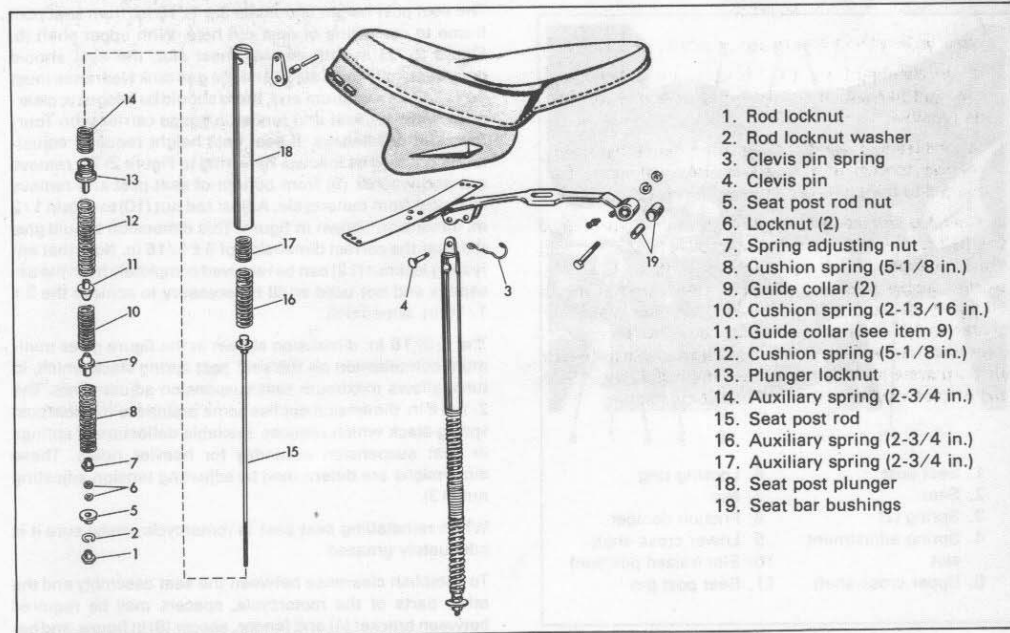

Figure 2-71. Seat Post - Exploded View

ASSEMBLING SEAT POST (Figure 2-71)

Seat post assembly is reverse of disassembly. Apply liberal coating of "Grease-All" grease to parts, working it into the springs.

For correct spring preloading, draw up spring adjusting nut to compress total visible spring length to 11 in. for standard spring and 10-1/2 in. for "D" heavy springs. Lock with one locknut (6). Turn on other locknut. Position rod nut (5) on rod so bottom end of rod extends through rod nut exactly 3/4 in. Lock adjustment with second locknut.

COMFORT FLEX SEAT - 1977 & LATER FL/FLH

GENERAL

The Comfort Flex seat is adjustable for seat spring firmness and seat spring damping. In addition, a raised position is provided for access to the oil tank and battery located under the seat.

SEAT SPRING FIRMNESS ADJUSTMENT (Figure 2-72)

Seat firmness is adjustable to accommodate varying amounts of rider weight by moving upper cross-shaft (5) either forward or rearward into spring adjustment slots (4). Five different slots apply varying amounts of preload to seat springs (3). The front slot provides the greatest firmness - suitable for the heaviest rider/passenger combination. The rear slot provides the least firmness - suitable for the lightest rider without passenger.

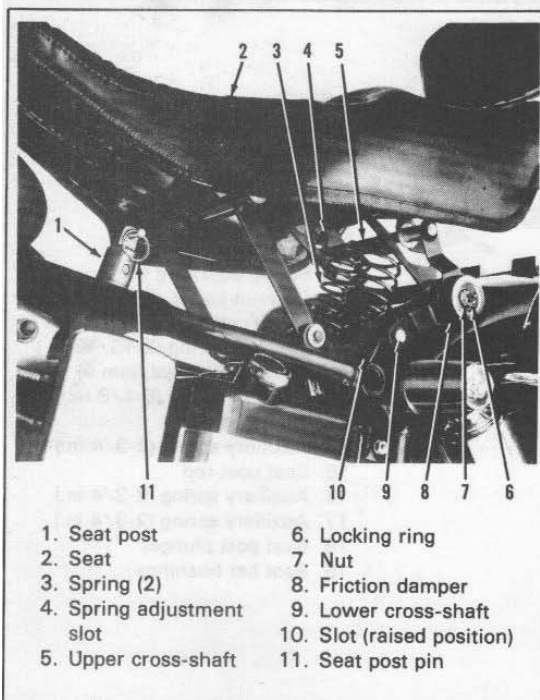

Figure 2-72. Comfort Flex Seat - Models FL and FLH

SEAT SPRING DAMPING ADJUSTMENT

Seat spring damping is controlled by friction damper (8) located on left side of seat. The tightness of nut (7) determines the loading on the damper friction washer. Tightening nut (7) increases damping; loosening nut decreases damping. It is recommended that nut (7) be set "finger tight" initially and increased as necessary to prevent any objectionable spring rebounding when traveling over rough surfaces. Remove locking ring (6) to make adjustments and replace when finished.

RAISING SEAT

To place seat in raised position for access to oil tank and battery, remove seat post pin (11), lift seat up toward rear and place lower cross-shaft (9) into upper position of slot (10). The seat is in the raised position in the figure.

REMOVING AND INSTALLING SEAT ASSEMBLY (Figure 2-73)

Referring to Figure 2-73, pull out pin (1) from seat post (2). Lift seat up into raised position. Remove two bolts (3), nuts and washers which attach bracket (4) to fender through holes (5). Remove two clamps (6) which attach seat to frame cross tube (7). The seat will now be freed and can be lifted off the motorcycle.

To reinstall seat assembly, reverse the procedure given above for removal while observing for correct clearances. The seat post height should be $3 \pm 1/16$ in. from seat post frame to centerline of post pin hole. With upper shaft (5, Figure 2-72) in fifth or rear most slot, the seat should compress fully to its stops and the gas tank clearance must be 1-1/2 in. minimum and, there should be adequate clearance between seat and fender, luggage carrier with Tour-Pak, and saddlebags. If seat post height requires adjustment, proceed as follows. Referring to Figure 2-73, remove nut and washer (9) from bottom of seat post and remove seat post from motorcycle. Adjust rod nut (10) to obtain 1/2 in. dimension shown in figure. This dimension should give the seat the correct dimension of $3 \pm 1/16$ in. Note that adjusting locknut (12) can be removed completely from the assembly and not used at all if necessary to achieve the $3 \pm 1/16$ in. dimension.

The 1-5/16 in. dimension shown in the figure gives minimum compression on the seat post spring stack which, in turn, allows maximum seat suspension adjustments. The 2-1/16 in. dimension applies some preload to the seat post spring stack which reduces available deflection of springs in seat suspension assembly for heavier riders. These dimensions are determined by adjusting tension adjusting nut (13).

When reinstalling seat post in motorcycle, make sure it is adequately greased.

To establish clearance between the seat assembly and the other parts of the motorcycle, spacers may be required between bracket (4) and fender, spacer (8) in figure, and between cross tube (7) and seat base. Minor changes can be made by simply adding shim stock at these two locations.

DISASSEMBLY AND ASSEMBLY

After removal from motorcycle, the seat assembly is partially disassembled by removing items 14 through 20 in the order shown in Figure 2-73. Reassemble in reverse order.

MAINTENANCE

Every 2000 miles, lubricate the seat suspension pivot bushings.

Periodically, check mounting bolts and clamps for tightness.

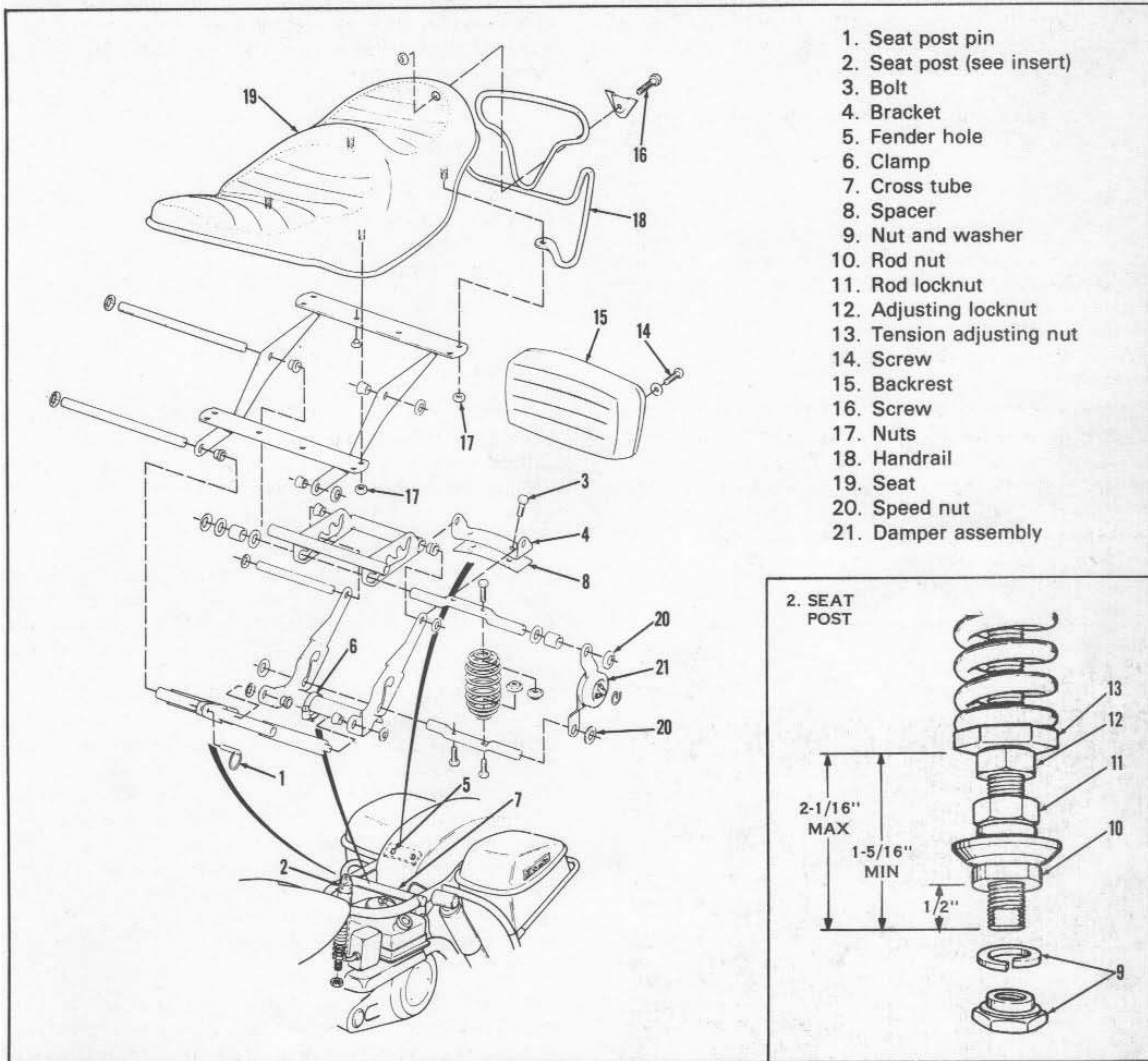

Figure 2-73. Comfort Flex Seat - Exploded View

FIBERGLASS

BODY CARE

GENERAL

Parts are made of molded fiberglass. There are 3 types of fiberglass material finishes:

1. **Gel Coat finish:** This finish is made of a special pigment and blended polyester resin several thousandths of an inch thick.
2. **Molded-in-Color finish:** This finish is molded into the fiberglass material which is the same color throughout its thickness.
3. **Painted finish:** This finish is painted on the natural color fiberglass material using standard painting procedure.

The Gel Coat and molded-in-color finishes require minimum care and can be kept new looking by following these easy maintenance rules:

Clean, buff and wax the exterior periodically to renew finish.

An automotive wax type cleaner containing fine rubbing compound is suitable for removing minor scratches and scuffs. Scratches which are not removed by the rubbing compound can be removed by wet sanding with 400 grit sandpaper. Then wet sand with 600 grit sandpaper, rebuff and apply wax polish.

Care should be taken not to cut through the gel coat surface when buffing. A power buffer may be used with care or the surface may be buffed by hand, using a rubbing compound.

REPAIRS

GENERAL

Patch and fill in deep scratches, scars and small breaks.

Repair any major breaks as soon as possible, to avoid any additional damage.

For damage to the gel coat finish, a can of Gel Coat of the same color and a small amount of catalyst is needed. For damage to the molded-in-color surface, a can of Filler Coat of the same color and a small amount of catalyst is needed. For deeper holes, breaks, or gouges, some fiberglass mat and pre-accelerated polyester resin will also be required. Gel Coat and Filler Coat with catalyst are available in kit form from the Harley-Davidson Motor Co. The other materials including fiberglass mat, and pre-accelerated polyester resin are supplied in fiberglass repair kits which are available at most marine or automotive supply stores.

Damage to the painted type finish can be repaired by sanding, priming and painting using regular painting procedure.

SURFACE FINISHING

This type of damage may be classified as damage to the gel coat only, or a hole or gouge that is deep enough to slightly penetrate fiberglass material. Repair as follows:

1. To be sure that the area to be patched is dry, clean and free of any wax or oil, wash with lacquer thinner.
2. Roughen the bottom and sides of the damaged area, using a power drill with a burr attachment. Feather the edge surrounding the scratch or gouge, being careful not to undercut this edge. See Figure 2-74.

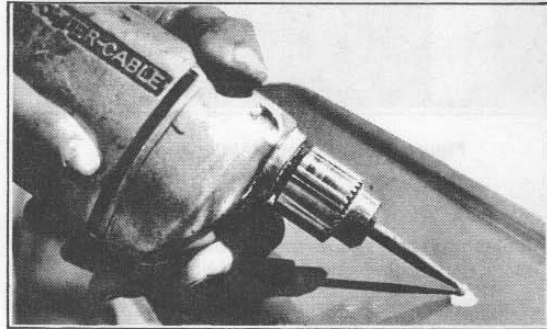

Figure 2-74. Roughing Damaged Area

3. A small amount of gel coat, the same color as the finish should be placed in a small can lid or on a piece of cardboard. Use just enough to fill the damaged area. If damage has penetrated through to fiberglass material, an equal amount of fibers, which can be taken from glass mat and shredded into small fibers, should be mixed with the gel coat – using a putty knife or flat stick. Add three drops of catalyst per teaspoon of gel coat using any eye dropper. Be sure to mix the catalyst thoroughly for maximum working time. Maximum working time (pot life) will be about 15 to 20 minutes in which time it begins to “gel.” See Figure 2-75.



Figure 2-75. Mixing Gel Coat Glass Fibers

4. Fill the scratch or hole above the surrounding undamaged area about 1/16 in., working the material into the damaged area with the sharp point of a knife. Be careful to puncture and eliminate any air bubbles which may occur. See Figure 2-76.

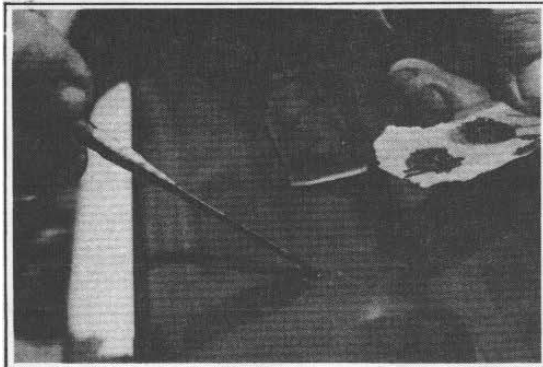

Figure 2-76. Filling Hole or Scratch

NOTE

If fiberglass fibers have not been used in mixture, skip steps 5 through 7 and proceed with step 8.

5. When the patch feels rubbery to touch (10-15 minutes), trim the patch flush with the surface, and then allow to cure completely (30-60 minutes). Patch will shrink slightly as it cures, making a depression. See Figure 2-77.

6. Carefully roughen up the bottom and edges of the depression, using the electric drill with burr attachment, as in Step 2. Feather into surrounding gel coat; do not undercut.

7. Again mix a small amount of gel coat with catalyst - do not use glass fibers. Using your finger or putty knife, fill the depression with gel coat 1/16 in. above the surrounding surface.

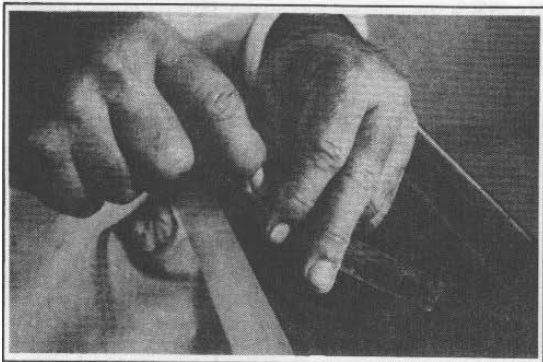

Figure 2-77. Trimming Patch

8. Spread the gel coat level with the surrounding area and allow to cure (30-60 minutes). See Figure 2-78. Gel coat can be covered with cellophane, if desired, to aid in spreading evenly. Remove cellophane after gel coat has cured.

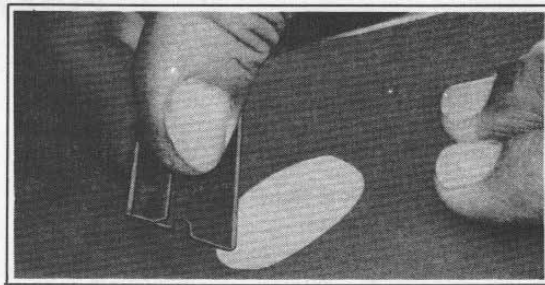

Figure 2-78. Spreading Gell Coat Evenly

9. Sand the patched area, using a sanding block with 600-grit wet sandpaper. Finish by buffing with fine rubbing compound such as DuPont #606 and waxing. Weathering will aid to blend touch-up if a slight color difference can be observed. See Figure 2-79.

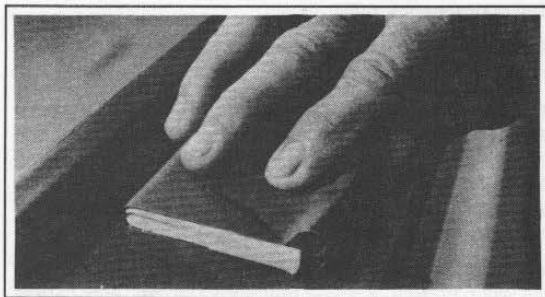

Figure 2-79. Sanding Patch

NOTE

Where surface color of part has changed due to weathering, color match of patch may not be satisfactory. In this case, entire panel must be sprayed.

Thin Gel coat with acetone (1 to 1 ratio) and spray panel, blending sprayed area into a radius or corner on the part. Use a touch-up spray gun such as the Binks Model 15. After Gel coat is hard, buff and polish sprayed area.

MOLDED-IN-COLOR SURFACE REPAIRS

This type of damage consists of a scratch, hole or gouge that is deep enough to slightly penetrate fiberglass material.

Repair as follows:

1. To be sure that the area to be patched is dry, clean and free of any wax or oil, wash with lacquer thinner.
2. Roughen the bottom and sides of the damaged area, using a power drill with a burr attachment. Feather the edge surrounding the scratch or gouge, being careful not to undercut this edge. See Figure 2-74.

3. A small amount of Filler coat, the same color as the finish should be placed in a small can lid or on a piece of cardboard. Use just enough to fill the damaged area. Add three drops of catalyst per teaspoon of Filler coat using an eye dropper. Be sure to mix the catalyst thoroughly for maximum working time. Maximum working time (pot life) will be about 15 to 20 minutes at which time it begins to "gel."

4. Fill the scratch or hole slightly above the surrounding undamaged area, working the Filler coat into the damaged area with a putty knife. Be careful to puncture and eliminate any air bubbles which may occur. Patch can be covered with cellophane to aid in spreading evenly (see Figure 2-78). Allow to cure completely before removing cellophane.

5. Sand smooth with 220-grit sandpaper; then use 600-grit for finish sanding. Blend into surrounding area using 600-grit sandpaper. Buff with polishing compound such as DuPont #600 and finish with paste wax.

NOTE

Where surface color of part has changed due to weathering, color match of patch may not be satisfactory. In this case, entire panel must be sprayed.

Thin Gel Coat with acetone (1 to 1 ratio) and spray panel, blending sprayed area into a radius or corner on the part. Use a touch-up spray gun such as the Binks Model 15. After Gel Coat is hard, buff and polish sprayed area.

PATCHING OF HOLES, PUNCTURES AND BREAKS

If possible, work in shaded spot or in a building where the temperature is between 70° and 80°F.

1. Be sure surface is clean and dry where repair is to be made. Remove all wax and dirt from the damaged area.
2. Prepare injured area by cutting back fractured material to the sound part of the material. A keyhole or electric saber saw can be used to cut out the ragged edges. See Figure 2-80.

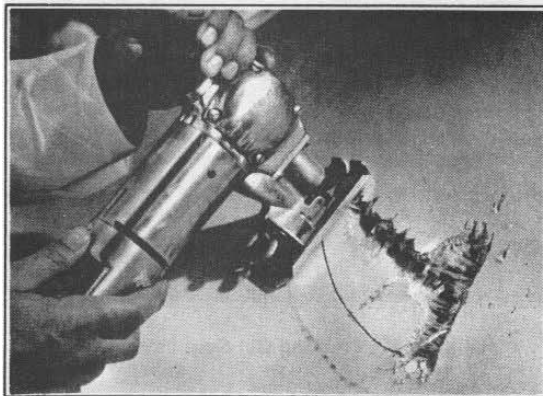

Figure 2-80. Sawing Out Damaged Area

3. Rough sand the inside surface, using 80-grit dry sandpaper, feathering back about two inches all around the hole in the area the patch will touch. See Figure 2-81.

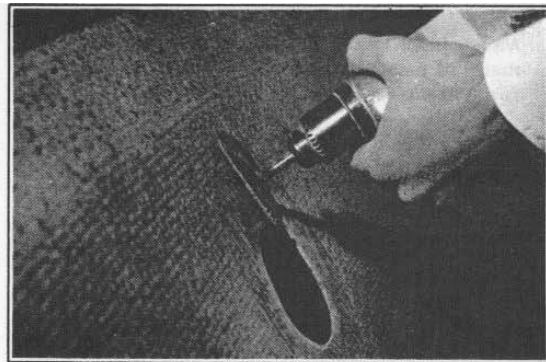

Figure 2-81. Rough Sanding Inside Surface

4. Cover a piece of cardboard or aluminum with cellophane and tape it to the outside surface with the cellophane facing toward the hole. Aluminum is used as backing where contour is present. The aluminum should be shaped the same as the contour. See Figure 2-82.

5. Cut glass mat to shape of hole, about 2 in. larger than hole.

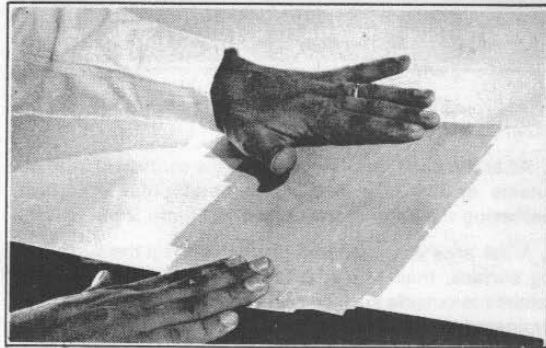

Figure 2-82. Taping on Backing

6. Mix a small amount of pre-accelerated resin and catalyst and daub resin on mat, thoroughly wetting it out. This may be done on a piece of cellophane or wax paper. See Figure 2-83.

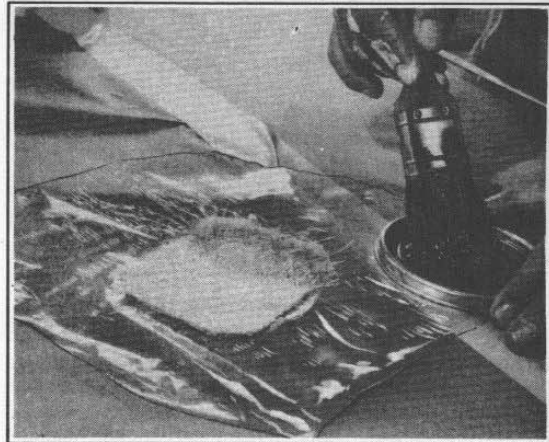

Figure 2-83. Applying Resin to Mat

NOTE

Mix resin 100 parts to 1 part catalyst for an approximate 30 minutes working time. Only mix enough resin for a given patch.

7. Lay patch over hole, cover with cellophane and squeegee out air bubbles. Allow one to two hours to cure, then remove cellophane. See Figure 2-84.

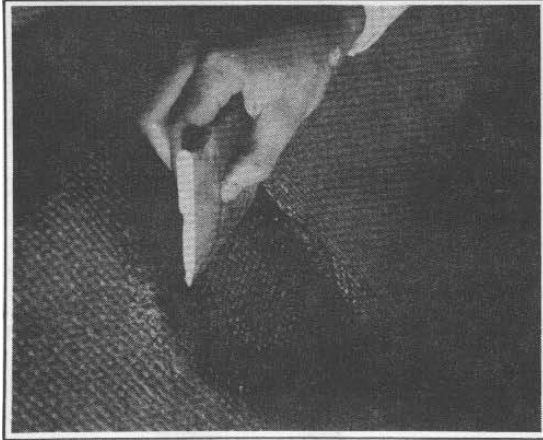

Figure 2-84. Squeegeeing Patch

8. After the patch is cured, remove the cardboard from the outside of the hole and rough sand outside surface, feathering the edge of the hole. See Figure 2-85.

9. Mask area with tape and paper to protect the surrounding surface; then repeat B Steps 5, 6, 7 and 8, applying patches to outside surface until enough material has been laminated to re-establish the original thickness of the section.

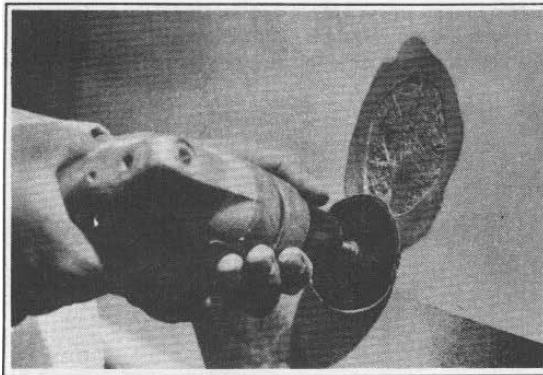

Figure 2-85. Rough Sanding Outside Surface

10. Allow the patch to cure overnight; then sand with dry 80-grit paper on power sander. Smooth the patch and blend it with surrounding surface. If air pockets are present, puncture and fill with catalyzed resin. Let cure and resand. See Figure 2-86.

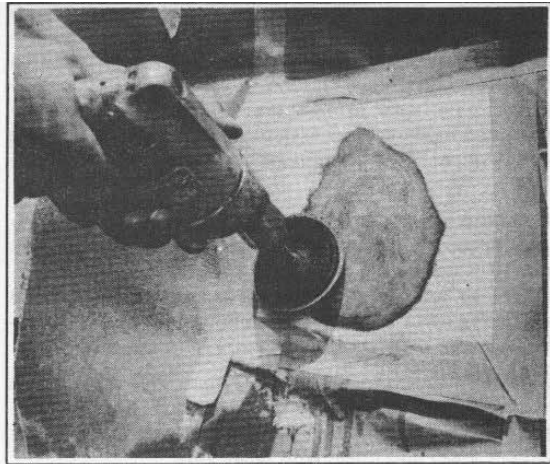

Figure 2-86. Blending Patch with Sander

11. Mix gel coat or filler coat with catalyst. Work Gel Coat into patch with fingers. See Figure 2-87. Filler Coat should be filled into patch with a putty knife.

12. Cover with cellophane and squeegee smooth. Allow to cure completely before removing cellophane.

13. Sand the patch with 220-grit wet sandpaper; then use 600-grit for finish sanding. On painted type surface, paint can be applied at this time. Buff with polishing compound and wax.

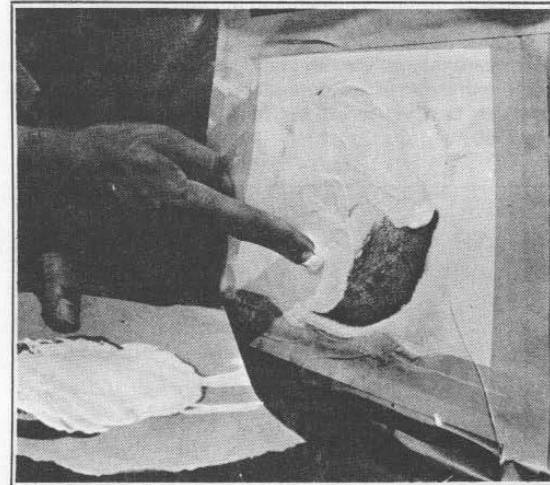

Figure 2-87. Working Gel Coat into Patch

NOTE

On Gel Coat finish, it may be necessary to repeat Steps 12 and 13 to ensure a smooth, even gel coat surface. See Figure 2-88.



Figure 2-88. Buffing Finish

For large areas the gel coat can also be sprayed.

Where surface color of part has changed due to weathering, color match of patch may not be satisfactory. In this case, entire panel must be sprayed.

Thin Gel Coat with acetone (1 to 1 ratio) and spray panel, blending sprayed area into a radius or corner on the part. Use a touch-up spray gun such as the Binks Model 15. After Gel Coat is hard, buff and polish sprayed area.

Heat lamps may be used if working conditions are cold.

CAUTION — Do not place lamp bulb closer than 14 inches to surface or the resin may blister.

TOOLS

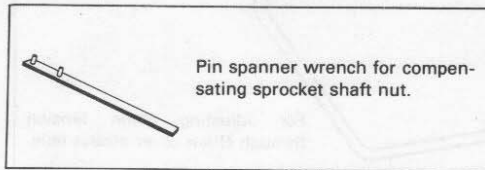

Pin spanner wrench for compensating sprocket shaft nut.

Part No. 94557-55 Compensating Sprocket Shaft Nut Wrench

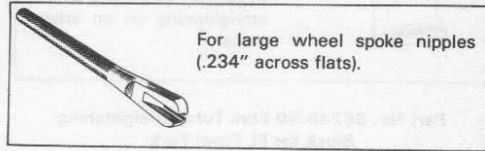

For large wheel spoke nipples (.234" across flats).

Part No. 94681-39 Spoke Nipple Wrench

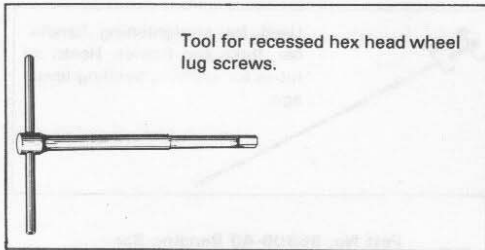

Tool for recessed hex head wheel lug screws.

Part No. 94619-35 Wheel Lug Wrench

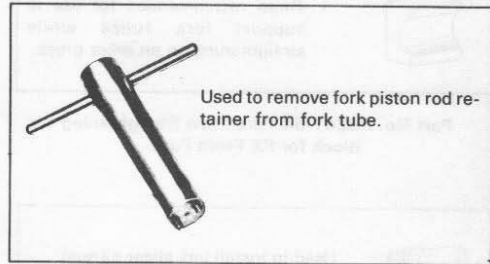

Used to remove fork piston rod retainer from fork tube.

Part No. 94694-52 Fork Piston Rod Retainer Wrench for FX Front Fork (1972 & Earlier)

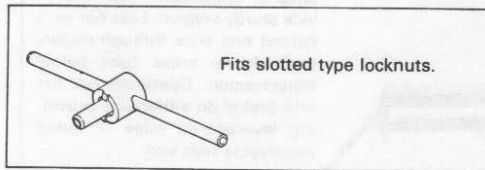

Fits slotted type locknuts.

Part No. 94630-67 Wheel Hub Bearing Locknut Wrench

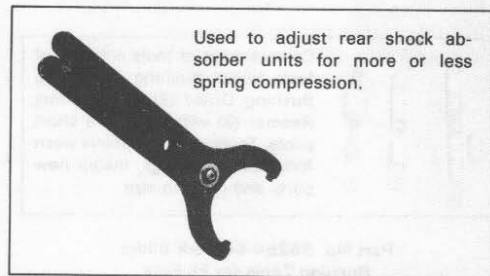

Used to adjust rear shock absorber units for more or less spring compression.

Part No. 94700-52B Rear Shock Spanner Wrench



For small wheel spoke nipples (.203" or .218" across flats)

Part No. 94682-61 Spoke Nipple Wrench

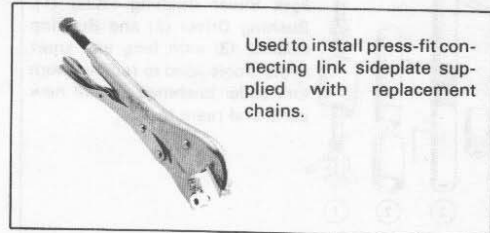

Used to install press-fit connecting link sideplate supplied with replacement chains.

Part No. 95020-66 Rear Chain Connecting Link Press Tool



Three recommended for use to support fork tubes while straightening on an arbor press.

Part No. 96246-50 Fork Tube Straightening Block for FL Front Fork



Three recommended for use to support fork tubes while straightening on an arbor press.

Part No. 96247-54 Fork Tube Straightening Block for FX Front Fork



Used to install fork slider oil seal.

Part No. 96250-50 Fork Slider Oil Seal Driver

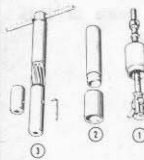

Complete set of tools consists of Fork Slider Bushing Puller (1), Bushing Driver (2) and Bushing Reamer (3) with long and short pilots. Tools used to remove worn fork slider bushings, install new parts and ream to size.

Part No. 96254-50 Fork Slider Bushing Tools for FL Fork

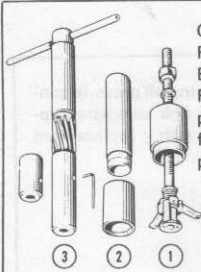

Complete set of tools consists of Fork Slider Bushing Puller (1), Bushing Driver (2) and Bushing Reamer (3) with long and short pilots. Tools used to remove worn fork slider bushings, install new parts and ream to size.

Part No. 96254-54 Bushing Tools for FX Front Fork (1972 & Earlier)

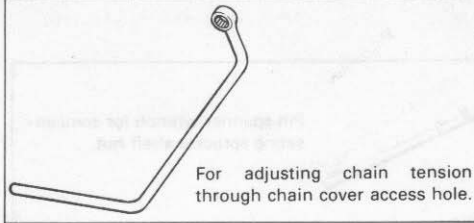

For adjusting chain tension through chain cover access hole.

Part No. 94644-65 Chain Adjuster Shoe Bolt Wrench

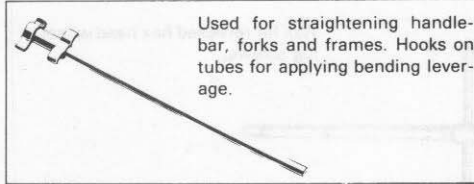

Used for straightening handlebar, forks and frames. Hooks on tubes for applying bending leverage.

Part No. 96806-40 Bending Bar

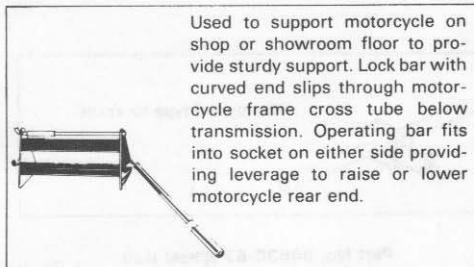

Used to support motorcycle on shop or showroom floor to provide sturdy support. Lock bar with curved end slips through motorcycle frame cross tube below transmission. Operating bar fits into socket on either side providing leverage to raise or lower motorcycle rear end.

Part No. 96810-63 Motorcycle Shop Stand

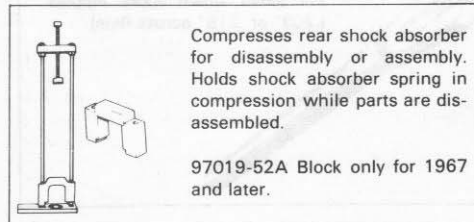

Compresses rear shock absorber for disassembly or assembly. Holds shock absorber spring in compression while parts are disassembled.

97019-52A Block only for 1967 and later.

Part No. 97010-52A Rear Shock Absorber Tool

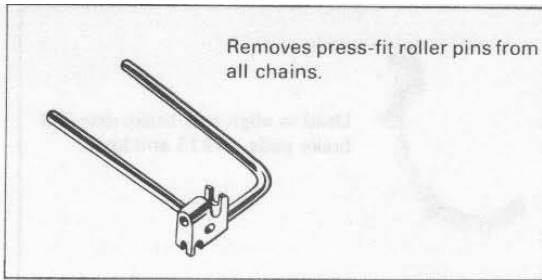

Removes press-fit roller pins from all chains.

Part No. 95021-29 Disassembling Chain Tool

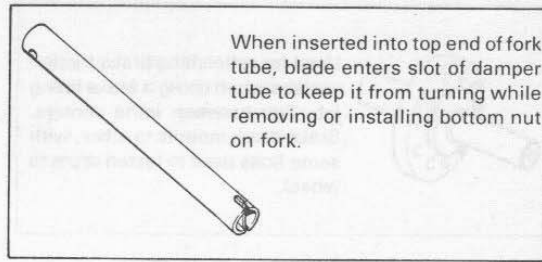

When inserted into top end of fork tube, blade enters slot of damper tube to keep it from turning while removing or installing bottom nut on fork.

Part No. 95991-69 Fork Damper Holding Tool for FX Front Fork (1972 & Earlier)

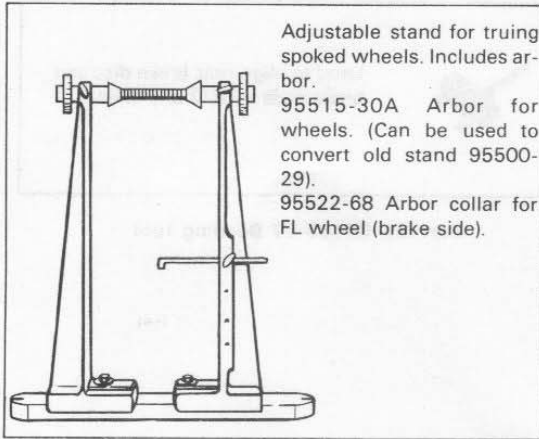

Adjustable stand for truing spoked wheels. Includes arbor.
 95515-30A Arbor for wheels. (Can be used to convert old stand 95500-29).
 95522-68 Arbor collar for FL wheel (brake side).

Part No. 95500-29A Wheel Truing Stand

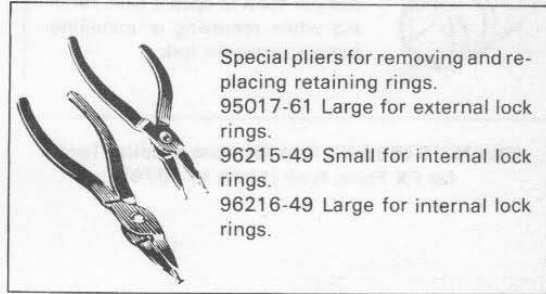

Special pliers for removing and replacing retaining rings.
 95017-61 Large for external lock rings.
 96215-49 Small for internal lock rings.
 96216-49 Large for internal lock rings.

Lock Ring Pliers

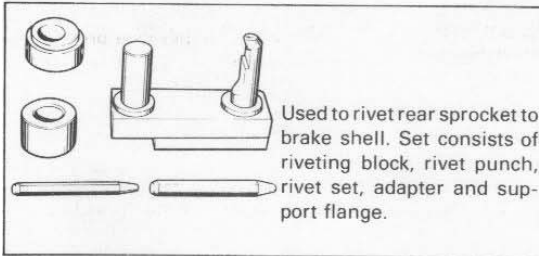

Used to rivet rear sprocket to brake shell. Set consists of riveting block, rivet punch, rivet set, adapter and support flange.

Part No. 95600-33B Sprocket Riveting Set

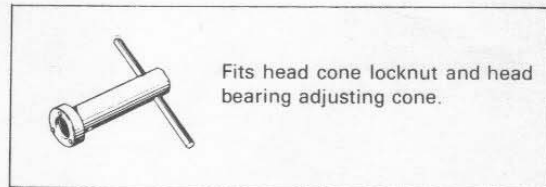

Fits head cone locknut and head bearing adjusting cone.

Part No. 96219-50 Frame Head Bearing Adjusting Cone, and Locknut Wrench

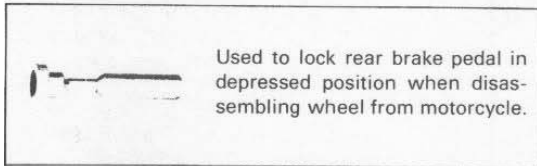

Used to lock rear brake pedal in depressed position when disassembling wheel from motorcycle.

Part No. 95875-58 Brake Pedal Locking Tool

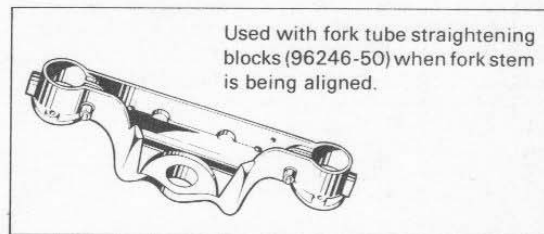

Used with fork tube straightening blocks (96246-50) when fork stem is being aligned.

Part No. 96245-51 Fork Stem and Cross Member Aligning Gauge

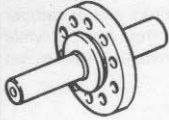

Used for refinishing brake friction surface when doing a brake lining job. Fits between lathe centers. Brake drum mounts to arbor, with same bolts used to fasten drum to wheel.

Part No. 97280-60A Brake Drum Turning Arbor



When inserted into top end of fork tube, socket fits over flats on damper tube to keep it from turning while removing or installing bottom screw on fork.

Part No. 94556-73 Fork Damper Holding Tool for FX Front Fork (1973 to 1976)



Used to align rear brake disc and brake pads - 1973 and later.

Part No. 97168-77 Alignment Gauge



Used to align rear brake disc and brake pads - 1973 and later.

Part No. 97169-77 Bending Tool

TABLE OF CONTENTS

	PAGE
General	3-1
Cylinder Head	3-11
Cylinder and Piston	3-15
Gearcase	3-21
Crankcase	3-29
Fuel System	3-39
Tools	3-61

GENERAL

SPECIFICATIONS

VALVES

Fit in guide (EX)0035-.0055 in.
Fit in guide (IN)0018-.0038 in.
Spring	
(Outer)	104-120 lbs at 1-3/8 in. (closed) 179-195 lbs at 1 in. (open)
Free length	1-31/32 in.
(Inner)	26-32 lbs at 1-3/16 in. (closed) 69-81 lbs at 51/64 in. (open)
Free length	1-23/64 in.
Tappet adjustment ...	Hydraulic tappet unit compressed 1/8 in. from fully extended position

ROCKER ARM

Fit in bushing0005-.002 in. loose
End clearance004-.025 in.

PISTON

Fit in cylinder001-.002 in. loose
Ring gap010-.020 in.
Compression ring side clearance004-.005 in.
Oil ring side clearance003-.005 in.
Piston pin fit	Light hand press at 70° F.

CONNECTING ROD

Piston pin fit0008-.0012 in. loose
End play between flywheels005-.025 in.
Fit on crankpin001-.0015 in. loose

OIL PUMP PRESSURE

At normal operating temperature (2000 rpm) oil pressure should be	12-35 psi
--	-----------

IGNITION TIMING

Breaker point setting018 in. gap
Ignition Timing	
(Retarded)	5° BTC (1/64 in. before piston T.C.)
(Automatic	
Advance)	35° BTC (7/16 in. before piston T.C.)
Spark plug gap setting028 to .033 in.

TAPPETS

Guide fit0025 tight - .0025 loose
Fit in guide001-.003 in. loose
Roller fit0005-.001 in.
Roller end clearance008-.010 in.

GEARCASE

Timer gear end play003-.007 in.
Idler gear end play003-.020 in.
Breather gear end play001-.005 in.
Cam gear shaft in bushing0008-.0018 in.
Cam gear shaft in bearing0005-.0030 in.
Cam gear end play001-.005 in.
Intermediate and idler gear (on shafts)001-.0015 in.
Oil pump drive shaft (crankcase bushing)0008-.0012 in.

FLYWHEEL ASSEMBLY

Gear shaft nut torque	170 ft-lbs
Sprocket shaft nut torque 1970-71	170 ft-lbs
Sprocket shaft nut torque 1972 & later	400 ft-lbs
Crank pin nuts torque	200 ft-lbs
Runout (flywheels)003 in. maximum at rim
Runout (mainshafts)001 in. maximum

SPROCKET SHAFT BEARING

Cup fit in crankcase0012-.0032 in. tight
Cone fit on shaft0002-.0015 in. tight
End play001-.006 in.

PINION SHAFT BEARINGS

Roller bearing fit0004-.0008 in. loose
Cover bushing fit0005-.0012 in. loose

DESCRIPTION

The engine is a two-cylinder, four-cycle, air cooled, overhead-valve, V-type engine. It has three major component assemblies: cylinder, crankcase and gearcase.

Cylinder assemblies include cylinder head, valves, rocker arms and piston. Cylinders mount on the engine crankcase in a 45 degree "V," with both connecting rods connected to a single crank pin.

The reciprocating, linear motion of the piston in the cylinder is converted to circular motion in the crankcase. The built-up crankshaft consists of an off-center crank pin interposed between two counterweighted flywheels which rotate on two end shafts (pinion and sprocket shafts) supported by antifriction roller bearings. The lower end of the rear cylinder connecting rod is forked to fit around the single-end front cylinder connecting rod, allowing a single connecting rod-crankpin connection to the flywheel.

Flywheel rotation is clockwise (viewing engine from right side). Using the front cylinder firing position as a starting point, the rear cylinder fires at 315 degrees rotation (360 degrees minus the 45 degrees between cylinders). The front fires in an additional 405 degrees (360 degrees plus the 45 degrees between cylinders), completing the 720 degrees of flywheel rotation necessary for the four piston strokes.

The gearcase is located on the right side of the crankcase and houses a gear train which operates and times the valves and crankcase breather. The rotary crankcase breather valve is located between crankcase and gearcase compartments and functions to relieve crankcase pressure caused by downstroke of pistons, and controls the flow of oil in the lubrication system.

A single camshaft with four cam lobes is gear driven. The engine valves are opened and closed through the mechanical linkage of tappets, push rods and rocker arms. Tappets serve to transmit the cam action to the valve linkage. Hydraulic lifters installed in the tappets automatically compensate for heat expansion to maintain a no-lash fit of parts. Valve and breather timing are obtained by meshing gearcase gears with timing marks aligned.

Ignition spark is produced by operation of circuit breaker, ignition coil and spark plugs. The breaking of circuit breaker points by a cam on the camshaft determines the spark timing.

Ignition spark is produced through operation of a single set of circuit breaker points by a double-lobe cam on the circuit breaker shaft. The narrow lobe times the front cylinder. The wide lobe times the rear cylinder. Both spark plugs fire each crankshaft revolution. However, the spark in one cylinder occurs ineffectually during its exhaust stroke.

Most other engine components function similar to usual internal combustion engine design. For further description of part function, see pertinent manual sections.

GASOLINE

CAUTION — Use a good quality "Premium" grade leaded gasoline. If "Premium" grade is unavailable, "Regular" grade may be used temporarily. Do not use unleaded grades such as "No-Lead."

LUBRICATION

The engine is lubricated by a pressure system circulating oil from the tank through the moving parts and back to tank. For adequate lubrication the tank must contain an ample supply of clean oil at all times.

Oil consumption varies from 250 to 500 miles per quart depending on the nature of service, solo or sidecar, fast or moderate driving, and how well the engine is kept tuned. If mileage is not within this range, see following engine overhaul section.

Remove tank cap and check oil supply at not more than 300 miles after each complete refill. If level is down near "Refill" mark on gauge rod, add oil. When level is down to "Refill" mark, add two quarts. Engine will run cooler and usage will be less with oil level well up in tank.

The oil tank capacity is one gallon. The tank is full when the oil level is about one inch from top. Do not fill above this level. The tank needs some air space. Tighten the cap securely to prevent leakage.

Change oil in new engine after first 500 and 1000 miles, and at about 2000 mile intervals thereafter. Completely drain oil tank of used oil and refill with fresh oil. If service is extremely hard, hot, on dusty roads or in competition, drain and refill at shorter intervals. Clean or replace oil filter as specified in maintenance schedule. Draining should be done while oil is hot. It is not necessary to drain the crankcase for it does not accumulate more than about 5 oz. of oil at any time. At the time of the first oil change, and along with at least every second oil change thereafter, thoroughly flush and clean out tank with kerosene to remove any sediment and sludge that may have accumulated.

OIL COOLER (Model FXS)

The model FXS-1200 is equipped with an oil cooler as standard equipment. Oil cooler does not require periodic maintenance. When operating the motorcycle in temperatures below 50°F (10°C), it is recommended that the oil cooler cover, provided with your motorcycle, be installed otherwise engine will not warm up to proper operating temperature.

WINTER LUBRICATION

Combustion in any engine generates water vapor. When starting and warming up in cold weather, especially in freezing or cold weather, the vapor that gets into the crankcase condenses to water before the crankcase is hot enough to exhaust the vapor through the outside breather. If engine is run often enough to get the crankcase thoroughly warmed up, most of this water is again vaporized and blown out through the breather. A moderately driven engine, making short runs and seldom allowed to thoroughly warm up, will accumulate increasing amounts of water in the oil tank. This water will, in freezing weather, become slush or ice and if allowed to accumulate will block oil lines and damage the engine. Water mixed with oil for some time forms sludge that is harmful to the engine and causes rapid wear of various working parts. In winter the oil should be changed more often than in normal weather. Any engine used for short runs, particularly in commercial service, must have oil changed frequently and tank thoroughly flushed to remove water and sludge, before new oil is put in tank. The farther below freezing the temperature drops, the shorter the oil change interval should be.

CHANGING OIL

Run engine until it is fully warm. Remove oil tank plug and allow all oil to drain. Replace plug. Pour a quart of kerosene into tank and agitate by rocking motorcycle from side to side. Remove plug and drain. Replace plug and fill with recommended grade oil as follows:

Use Harley-Davidson Oil	Use Grade	Air Temperature (Cold Engine Starting Conditions)
Medium Heavy	75	Above 40°F
Special Light	58	Below 40°F
Regular Heavy	105	Severe operating conditions of high air temperatures (above 90°F).

OIL PRESSURE SIGNAL LIGHT

The oil signal light, located above ignition switch on instrument panel, indicates oil circulation.

If the oil signal light fails to go off at speeds above idling, it is usually due to low or a diluted oil supply. In freezing weather the oil feed pipe may clog with ice and sludge, preventing circulation of oil. A grounded oil signal switch wire, faulty signal switch, or trouble with oil pump will also cause the light to stay on. If the oil signal light fails to go off, always check the oil supply first. Then, if oil supply is normal, look inside the oil tank to determine if oil returns to the tank from the oil return pipe outlet located at front of oil tank near filler hole when the engine is running. If it is returning to the tank there is some circulation, and engine may be run a short distance if necessary. If no oil returns, shut off engine until trouble is located and corrected.

OPERATING OIL PRESSURE

Operating oil pressure may be checked as follows:

Fill oil tank to proper level. Disconnect oil pressure switch wire at top of switch and remove switch. Install Oil Pressure Gauge, Part No. 96921-52. Attach gauge bracket to motorcycle and road run or simulate road running until engine is completely warmed. A full operating temperature is essential for accurate gauging. Oil pressure should be 12-35 psi at 2000 rpm with oil at normal operating temperature.

OIL FILTER (Figure 3-1)

The tank is equipped with a large mouth filler opening and a screw cover with oil filter attached.

Oil filter element (3) should be replaced at every oil change. To service filter element, remove cap from oil tank, remove

retaining clip (1) and washer (2) and pull out filter. Make certain O-ring is positioned against filter cup flange (7) when filter is installed in tank.

SERVICING OIL TANK CAP AND FILLER OPENING

To disassemble, follow order shown in Figure 3-1. Assembly is reverse order of disassembly. Clean and inspect all parts. Replace any that are worn or damaged.

If oil leak should occur between the tank cap and the filler opening, with cap and gasket in serviceable condition, check the lip of the filler opening. A cap drawn too tight will bend the lip of the filler opening resulting in an imperfect seal between gasket and lip.

Drain oil from tank. Using a mallet as a driver and a block of wood as a cushion, bend the lip down until flush with sealing surface of tank cap. Remove nicks and rough spots with emery cloth. Flush tank before refilling.

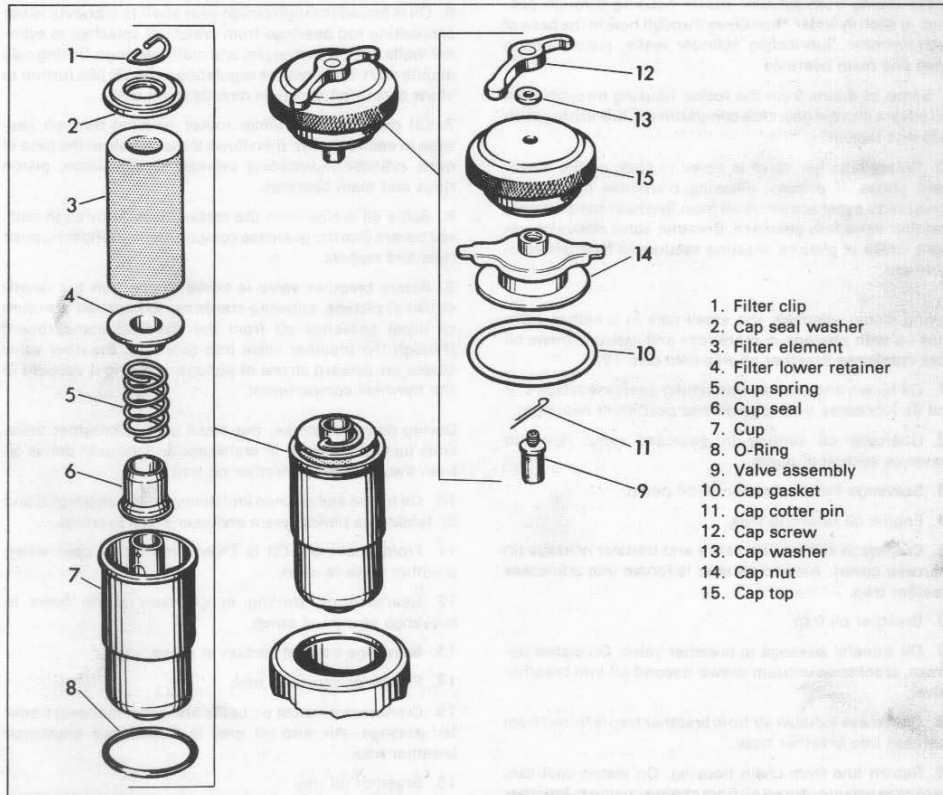

Figure 3-1. Oil Tank Filter - Exploded View

FL/FLH ENGINE OILING AND BREATHER SYSTEM – 1972 AND EARLIER (The following steps are called out on Figure 3-2)

1. Gravity feed from tank to feed pump.
2. Feed (pressure) section of oil pump.
3. Check valve prevents gravity oil drainage from tank to engine.
4. Oil pressure regulating valve limits maximum pressure. Surplus oil is dumped back into gearcase in front of breather valve.
5. Oil is forced through pinion gear shaft to lubricate lower connecting rod bearings from which oil splashes to cylinder walls, piston, piston pin and main bearings.
6. Oil is filtered through oil screen and forced through passages or external oil lines to lubricate rocker arm bushings, shafts, valve stems, valve springs and push rod sockets. A branch passage supplies oil to the hydraulic lifters.
7. Oil is bled from bypass oil for front chain lubrication.
8. Oil drains from cylinder rocker housing through passage in each cylinder, then flows through hole in the base of each cylinder, lubricating cylinder walls, piston, piston rings and main bearings.
9. Some oil drains from the rocker housing through push rod covers into the gearcase compartment, lubricating push rods and tappets.
10. Rotary breather valve is timed to open on the downward stroke of pistons, allowing crankcase exhaust air pressure to expel scavenge oil from flywheel compartment breather valve into gearcase. Breather valve closes on upward stroke of pistons, creating vacuum in flywheel compartment.

During piston upstroke, the small port in breather valve lines up with passage in crankcase and vacuum draws oil from crankcase breather oil trap (see step 17).

11. Oil blown and drained into timing gearcase (steps 6, 8 and 9), lubricates timing gears and gear shaft bearings.
12. Gearcase oil settling in gearcase sump flows to scavenge section of pump.
13. Scavenge (return) section of oil pump.
14. Engine oil return to tank.
15. Crankcase exhaust air baffle and transfer passage (in gearcase cover). Air and oil mist is forced into crankcase breather trap.
16. Breather oil trap.
17. Oil transfer passage to breather valve. On piston upstroke, crankcase vacuum draws trapped oil into breather valve.
18. Crankcase exhaust air from breather trap is forced from gearcase into breather hose.
19. Return line from chain housing. On piston upstroke, crankcase vacuum draws oil from chain housing to breather valve. On piston downstroke, oil in breather valve is forced into gearcase.

3-4

20. Vent line to oil tank and chain housing.

21. Rear chain oiler.

22. Pressure switch fitting.

FL/FLH/FX ENGINE OILING AND BREATHER SYSTEM – 1973 AND LATER (The following steps are called out on Figure 3-2A)

1. Gravity feed from oil tank to feed pump.
2. Feed (pressure) section of pump.
3. Check valve prevents gravity oil drainage from tank to engine.
4. Oil is filtered through oil screen and forced through passages or external oil lines to lubricate rocker arm bushings, shafts, valve stems, valve springs and push rod sockets. A branch passage supplies oil to the hydraulic lifters.
5. Pressure regulating valve maintains correct pressure in system. When oil reaches rocker arms and lifters, regulating valve lifts and allows pressurized oil to flow to pinion gear shaft.
6. Oil is forced through pinion gear shaft to lubricate lower connecting rod bearings from which oil splashes to cylinder walls, piston, piston pin, and main bearings. During cold engine start-up, pressure regulating valve (5) lifts further to allow excess oil to return directly to oil tank.
7. Oil drains from cylinder rocker housing through passage in each cylinder, then flows through hole in the base of each cylinder, lubricating cylinder walls, piston, piston rings and main bearings.
8. Some oil drains from the rocker housing through push rod covers into the gearcase compartment, lubricating push rods and tappets.
9. Rotary breather valve is timed to open on the downstroke of pistons, allowing crankcase exhaust air pressure to expel scavenge oil from the flywheel compartment through the breather valve into gearcase. Breather valve closes on upward stroke of pistons, creating a vacuum in the flywheel compartment.

During piston upstroke, the small port in breather valve lines up with passage in crankcase and vacuum draws oil from the crankcase breather oil trap.

10. Oil blown and drained into timing gearcase (steps 8 and 9), lubricates timing gears and gear shaft bearings.
11. Front chain oil. Oil is blown into chain case when breather valve is open.
12. Gearcase oil settling in gearcase sump flows to scavenge section of pump.
13. Scavenge (return) section of pump.
14. Engine oil return to tank.
15. Crankcase exhaust air baffle and gearcase cover transfer passage. Air and oil mist is forced into crankcase breather trap.
16. Breather oil trap.
17. Oil transfer to breather valve. On piston upstroke crankcase vacuum draws trapped oil into breather.

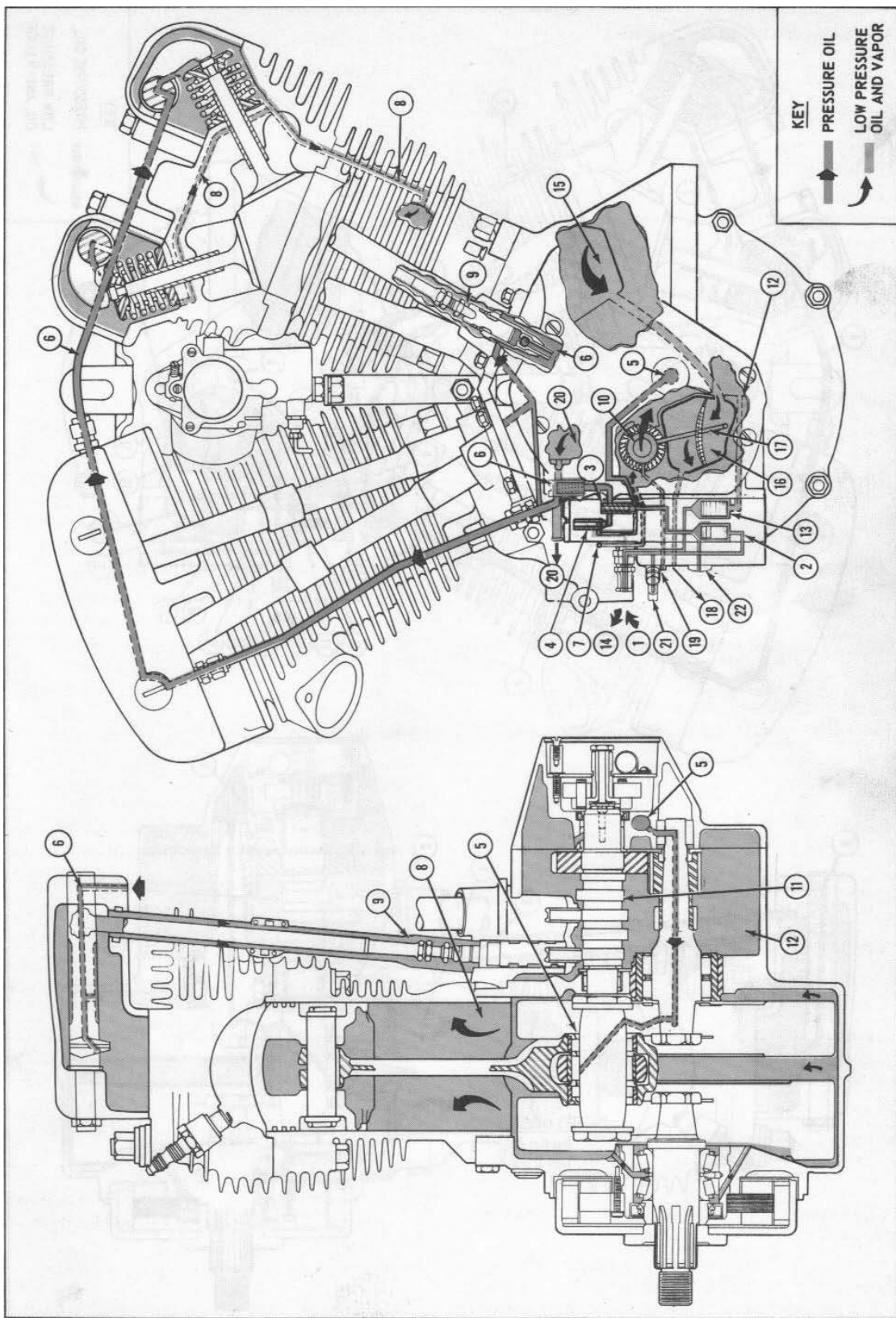

Figure 3-2. FL/FLH/FX Lubrication (1972 and Earlier)

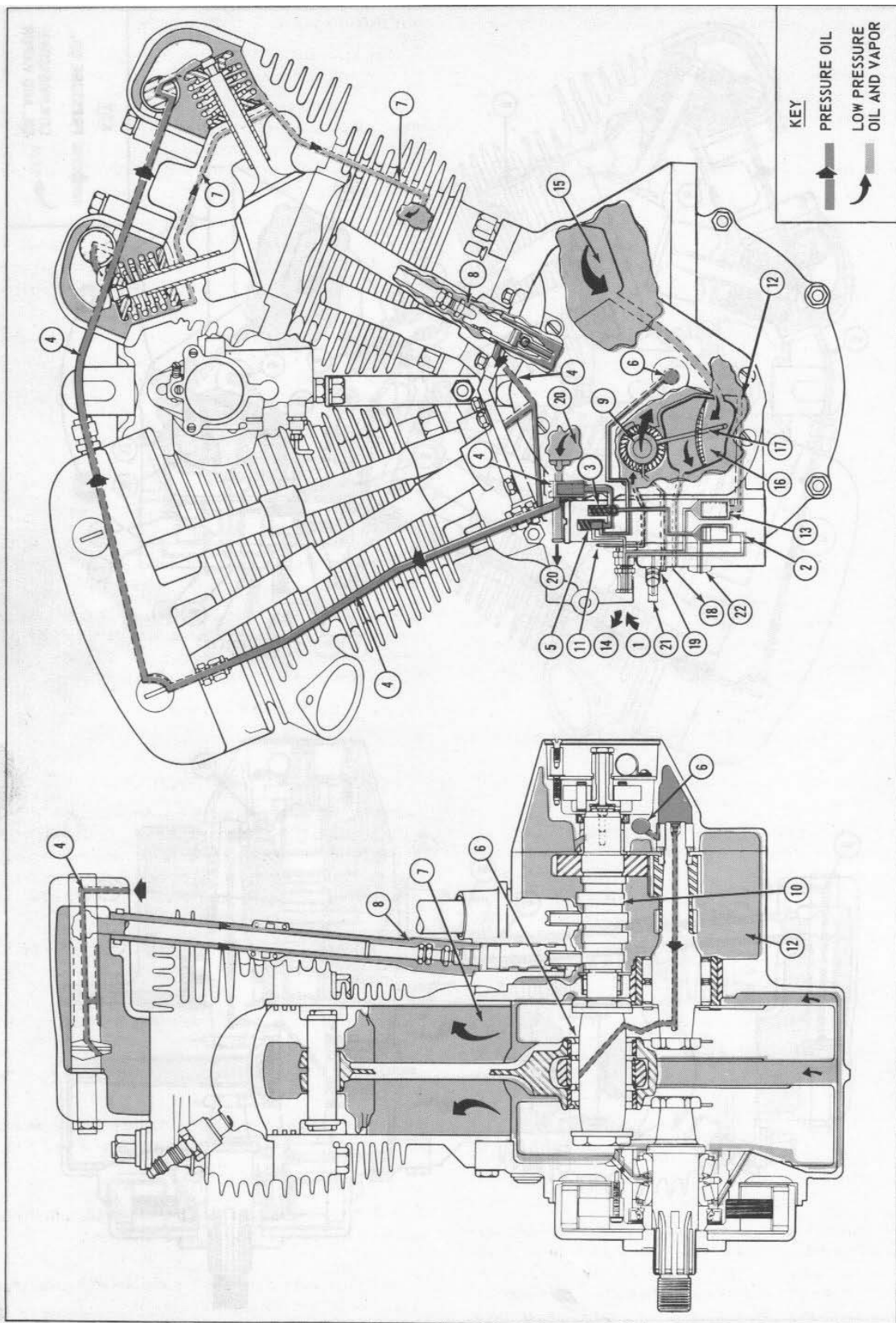

Figure 3-2A. FL/FLH/FX 1200 Lubrication System (1973 and Later)

18. Crankcase exhaust air escapes from gearcase through outside breather tube.
19. Return line from chain housing. On piston upstroke, crankcase vacuum draws oil from chain housing to breather valve. On piston downstroke, oil in breather valve is forced into gearcase.
20. Vent line to oil tank and chain housing.
21. Rear chain oiler.
22. Pressure switch fitting.

REPAIR AND DIAGNOSTIC PROCEDURE

GENERAL

When an engine needs repair, it is not always possible to definitely determine beforehand whether the engine can be repaired by disassembling only cylinders and heads, only gearcase; or whether engine must be completely disassembled for crankcase repair.

Usually, only upper-end repair is needed and it is recommended procedure to first strip motorcycle for cylinder head, cylinder and piston repair as described in "Stripping Motorcycle for Engine Repair," steps 1 through 9.

After disassembling cylinder head and cylinder it may be found that lower end repair is necessary. This requires removal of engine crankcase from frame as described in steps 9 through 16 in "Stripping Motorcycle for Engine Repair."

In cases where it has been definitely determined beforehand that the lower portion of engine (crankcase) is in need of repair, remove complete engine from chassis before starting disassembly as described in steps 1 through 16 of "Stripping Motorcycle for Engine Repair."

Symptoms indicating a need for engine repair are often misleading, but generally if more than one symptom is present, possible symptom causes can be narrowed down to make at least a partial trouble diagnosis. An above normal consumption of oil, for example, could be caused by several mechanical faults (see "Locating Troubles," Section 1). But when accompanied by a blue-gray smoke from the exhaust, and when low compression is present, it indicates the rings need replacing. Low compression by itself, however, indicates improperly seated valves, but worn rings.

A noisy engine is usually caused by loose bearings. Main bearings are generally more durable than rod bearings or bushings so the latter should be suspected first. Certain "knocking" noises may be caused by loose bearings, others by piston slap, a condition where piston or cylinder or both are worn out of round and loose fitting, allowing the piston to slap from front to rear of cylinder as it moves up and down.

Most frequently, valves, rings, pins, bushings and bearings need attention at about the same time. If the symptoms can be narrowed down through the process of elimination to indicate if any one of the above components is worn, it is best to give attention to all of the cylinder head and cylinder parts.

DIAGNOSING VALVE TRAIN NOISE

To diagnose and correct noisy hydraulic lifters and valve train components, use the following procedures:

1. With engine and oil at normal operating temperature, check oil pressure at 3000 rpm. If oil pressure is above 50 psi or below 5 psi, inspect oil pump, crankcase passages and oil hoses for restrictions or blockage. Repair or replace parts as necessary.
2. With engine running, raise push rod cover at the noisy lifter and check to see that oil is reaching the tappet. If oil is not reaching the tappet, inspect the passages in the tappet, tappet block and right crankcase for restrictions or blockage.

If oil is reaching the tappet, remove the hydraulic unit and inspect per procedure listed under "Valve Tappets and Guides." Clean tappet bore of all foreign material.

Replace hydraulic unit if necessary.

3. Examine push rod, hydraulic unit, tappet and tappet block for proper fits and any signs of unusual wear. Replace parts as necessary.
4. Visually inspect camshaft lobes for abnormal wear.
5. Remove camshaft and pinion gear, clean and inspect for wear and fit. Measure pitch diameters and check for out of round condition. Replace parts as necessary.
6. Remove cylinder head and rocker box assemblies. Check rocker arm end play and check for binding. Inspect valve stems for scuffing and check stem to guide clearance. Check valve seats for signs of looseness or shifting.
7. Grind valves and valve seats.

COMPRESSION TESTING PROCEDURE

Satisfactory engine performance depends upon a mechanically sound engine. In many cases, unsatisfactory performance is caused by combustion chamber leakage. A compression test can help determine the source of cylinder leakage. Use a compression tester such as the Sun model UTC-48 that has a screw-in type adapter.

A proper compression test should be performed with the engine at normal operating temperature when possible. Proceed as follows:

1. Disconnect spark plug wires, clean around plug base and remove plugs.
2. Connect compression tester to front cylinder per manufacturer's instructions.
3. With choke and carburetor throttle plates in wide open position, crank engine continuously until 5 to 7 full compression strokes are completed.

CAUTION — Make sure that throttle plate is in the closed position before starting engine after test.

4. Note gauge readings at the end of the first and last compression strokes. Record test results.
5. Repeat steps 2 through 4 on rear cylinder.

6. If the final readings are 90 psi or more and if the final readings do not indicate more than a 30 psi variance between cylinders, compression is considered normal. If compression does not meet specifications, see diagnostic chart below.

7. Inject approximately 1/2 oz. of SAE 30 oil into each cylinder and repeat the compression tests on both cylinders. Readings that are considerably higher during the second test indicate worn piston rings.

Diagnosis	Test Results
Ring Trouble	Compression low on first stroke, tends to build up on following strokes but does not reach normal. Improves considerably when oil is added to cylinder.
Valve Trouble	Compression low on first stroke, does not build up much on following strokes. Does not improve considerably with the addition of oil. Check tappet adjustment.
Head Gasket Leak	Same reaction as valve trouble.

STRIPPING MOTORCYCLE FOR ENGINE REPAIR

Use the following procedure to strip the motorcycle for either cylinder head and cylinder removal for repair with engine in chassis, or for engine removal for complete overhaul.

1. Remove seat.
2. Drain gas tank. Disconnect fuel line and remove gas tank.
3. To remove instrument cover take out mounting base center screw and pry off cover side plate located at trip mileage set screw.
4. Release seat clevis spring, pull clevis pin and tip seat forward.
5. Remove upper cylinder head bracket. Note washers between bracket and frame lug, use same washer when bracket is assembled.
6. Remove spark plugs to avoid damaging. Disconnect ground wire at battery.
7. Remove air cleaner cover, filter element, air cleaner back plate and air cleaner back plate support bracket from carburetor body.
8. Remove carburetor intake manifold clamps.
9. Disconnect throttle and choke controls from carburetor. Remove carburetor.
10. Remove exhaust pipes.

At this stage, the cylinder heads and cylinders may be removed.

To remove engine crankcase or complete engine, continue stripping motorcycle as follows:

11. Remove pivot bolt from left foot board and swing rear end of foot board down away from chain guard cover. Remove chain guard cover. Remove compensating sprocket shaft nut.

Remove clutch and sprocket assemblies as described in "Disassembling Clutch," Section 4.

Remove alternator magnet ring (rotor) using puller tool, Part No. 95960-52A. See "Alternator," Section 5.

12. Remove four bolts, attaching inner chain housing at engine. See "Removing and Repairing Inner Chain Housing," Section 2. Note that rear 2 bolts are safety wired to prevent loosening.

Loosen the 4 inner chain guards to transmission attaching bolts.

Remove chain oiler hose at oil pump. Remove other hoses from connections at back of chain housing.

13. Disconnect timer wire at coil; alternator plug from crankcase and remove rectifier/regulator.

14. Remove footboard rear stud nut from inside of frame member and front footboard mounting stud bolts from brake master cylinder by removing nut and lockwasher on back side. Remove brake master cylinder attaching stud bolt which passes through master cylinder and frame with a lockwasher and nut on back side of frame member. Remove brake master cylinder sideplate bolt located behind master cylinder plunger boot. Master cylinder and sideplate assembly is free to swing down away from engine crankcase. For FX models, remove footrest, brake, pedal assembly.

15. Remove exhaust system.

16. Disconnect wire from oil pressure switch. Drain oil tank and remove oil lines from oil pump. Remove crankcase breather pipe.

17. Remove two front and two rear engine mounting bolts. Engine is now completely stripped and may be removed from right side of motorcycle.

Assembly is essentially the reverse order of disassembly.

1. Install engine in chassis. Tighten mounting bolts to 35-40 ft-lbs torque.

2. Loosen transmission mounting bolts.

3. Install new O-ring on crankcase.

4. Check inner chain case housing bearing. Replace if necessary using Harley-Davidson "Stud and Bearing Mount," Part No. 99626-77 in bearing recess. Install new oil seal.

5. Connect chain case hose and install inner chain case on transmission mainshaft.

6. Loosely assembly chain case mounting bolts (finger tight) to crankcase.

7. Install chain housing four nuts on transmission studs and tighten to 30-35 ft-lbs torque.

8. Tighten chain case to engine mounting bolts to 18-22 ft-lbs torque.

9. Tighten transmission mounting nuts to 18-22 ft-lbs torque.
10. Install new safety wire on chain case to engine two rear mounting bolts.
11. Pack chain case bearing recess with grease.
12. Install clutch, compensating sprocket, primary chain and chain adjuster.
13. Install chain case cover, using a new gasket.
14. Assemble remainder of components in reverse order of disassembly.

IMPORTANT

After reassembly, mounting bracket bolts (32, Figure 3-3) must be tightened to 35-40 ft-lbs torque, chain housing must be air tight. Check using Vacuum Gauge, Part No. 96950-68. Remove one of the four screws securing the front chain inspection cover and in its place screw in the threaded fitting of the gauge. Then, with engine running, check gauge to see that there is a reading indicating 20 inches water pressure or more at 1500 rpm. Perform check with vent hose to tank pinched closed with a pliers. A lower reading indicates an air leak into chain housing either at gasket, solenoid, starter shaft, or hoses.

CYLINDER HEAD

REMOVING (Figure 3-3)

Before removing cylinder head assembly, strip motorcycle as described in "Stripping Motorcycle For Engine Repair." Free carburetor and manifold assembly from motorcycle by removing two manifold clamps and carburetor support bracket nut at crankcase.

Disconnect overhead oil feed line (1) and cylinder interconnecting oil line (4) at fittings.

Remove spring cap retainers (8) on push rod covers by prying down on cover spring cap with screwdriver wedged between cylinder cooling fins and pulling spring cap retainers out. Crank engine until valves are closed.

Remove five head bolts and washers (5) from each head. Lift cylinder head enough to slip out push rods (6) and push rod covers (7). Mark push rods so that they will be reassembled in same position. Remove cylinder head (9). Remove cylinder head gasket (10).

DISASSEMBLING (Figure 3-3)

Free the rocker arm cover (13) and gaskets (14) from cylinder head by removing stud nuts (11). Before further disassembly, carefully check the rocker arm pads and ball sockets for pitting and excessive wear. Also, check the rocker arm shaft (17) for proper end play.

Remove rocker arm shaft screw and O-ring (18), acorn nut and washer (15). Discard shaft screw O-ring. Tap rocker arm shaft (17) from cover and remove rocker arm (20) and spacer (16). Mark rocker arm shaft and arm in some manner so all parts may be returned to respective locations during assembly. Rocker arms are not interchangeable.

Compress valve springs using Valve Spring Compressor, Part No. 96600-36, and remove valve keys (23) from ends of valve stems as shown in Figure 3-4. Mark keys to identify them with their respective valves. Remove valve spring collars (24 and 27), springs (25 and 26) and valves (28). It is customary to reassemble valves in same cylinder head from which they were removed; therefore, before removing, mark them in some manner to identify them with front and rear cylinder head.

CLEANING AND INSPECTION

Clean outside of cylinder head with a wire brush. Bead blast or scrape carbon from head, top of cylinder, top of bore above ring path, and inlet and exhaust valve ports. When scraping carbon, be careful to avoid scratching or nicking cylinder head and cylinder joint faces or bore. Blow off loosened carbon or dirt with compressed air.

Wash all parts in Harley-Davidson "Gunk Hydro-Seal." Blow out oil passages in head. Be sure they are free of sludge and carbon particles. Remove loosened carbon from valve head and stem with a wire wheel. Never use a file or other hardened tool that will scratch or nick valve. Polish valve stem with very fine emery cloth or steel wool. Check valve stem for excessive wear.

Valve head should have a seating surface about 1/16 in wide, it should be free of pit marks and burn spots. Exhaust valves should contain carbon that is black or dark brown. White or light buff carbon indicates excessive heat and burning.

Valve seats are also subject to wear, pitting and burning. They should be resurfaced whenever valves are refinished. Clean valve guides with an expansion reamer and check for wear and valve stem clearance.

Inspect spark plug port threads for damage. Replace Heli-coil (30, Figure 3-3) if necessary with special inserting tool. If threads in head are damaged, a special plug type insert can be installed using a standard spark plug port repair kit.

Inspect valve springs for broken or discolored coils. Check free length or check tension of each spring. If a spring is more than 1/8 in. shorter than a new spring, or tension shows spring to be below low limit tension of new spring, replace it with a new spring. Check valve spring compression with valve spring tester against tolerances shown in "Engine Specifications."

Examine push rods, particularly the ball ends. Replace any rods that are bent, worn, discolored or broken. Check cup at end of rocker arm to make certain there are no chips broken out.

Blow out oil passages in rocker arms, rocker arm bearings and rocker arm covers.

If the rocker arm pads show uneven wear or pitting, dress on a grinder, maintaining original curve. If possible, compare with a new unit during this operation to ensure a correctly contoured surface.

Carefully check the rocker arm and shaft for wear. Replace rocker arm bushings if shaft is over .002 in. loose in bushings, as described in "Repairing Rocker Arms and Bearings."

REPAIRING ROCKER ARMS AND BEARINGS (Figure 3-3)

To replace worn bushings (19), press or drive them from the rocker arm. If bushing is difficult to remove, insert a 5/8-11 tap into bushing. From opposite side of rocker arm, drive out bushing and tap. Press replacement bushing into rocker arm, flush with arm end, oil hole correctly aligned and split portion of bushing towards top of arm. Using remaining old bushing as a pilot, line ream new bushing Harley-Davidson Reamer Tool, Part No. 94804-57. Repeat for other end of rocker arm. When reassembling rocker arm housing, install new O-rings (18).

REPLACING VALVE GUIDES

Replacing valve guides if necessary, must be done before valve seat and face are ground since the valve stem hole in valve guide is the basis from which all face and seat grinding is done. Valve stem-valve guide clearance is as follows: Exhaust valves, .004 in. to .006 in. loose; intake valves, .002 in. to .004 in. loose. If valve stems and/or guides are worn to exceed the maximum tolerances by more than .002 in., new parts must be installed.

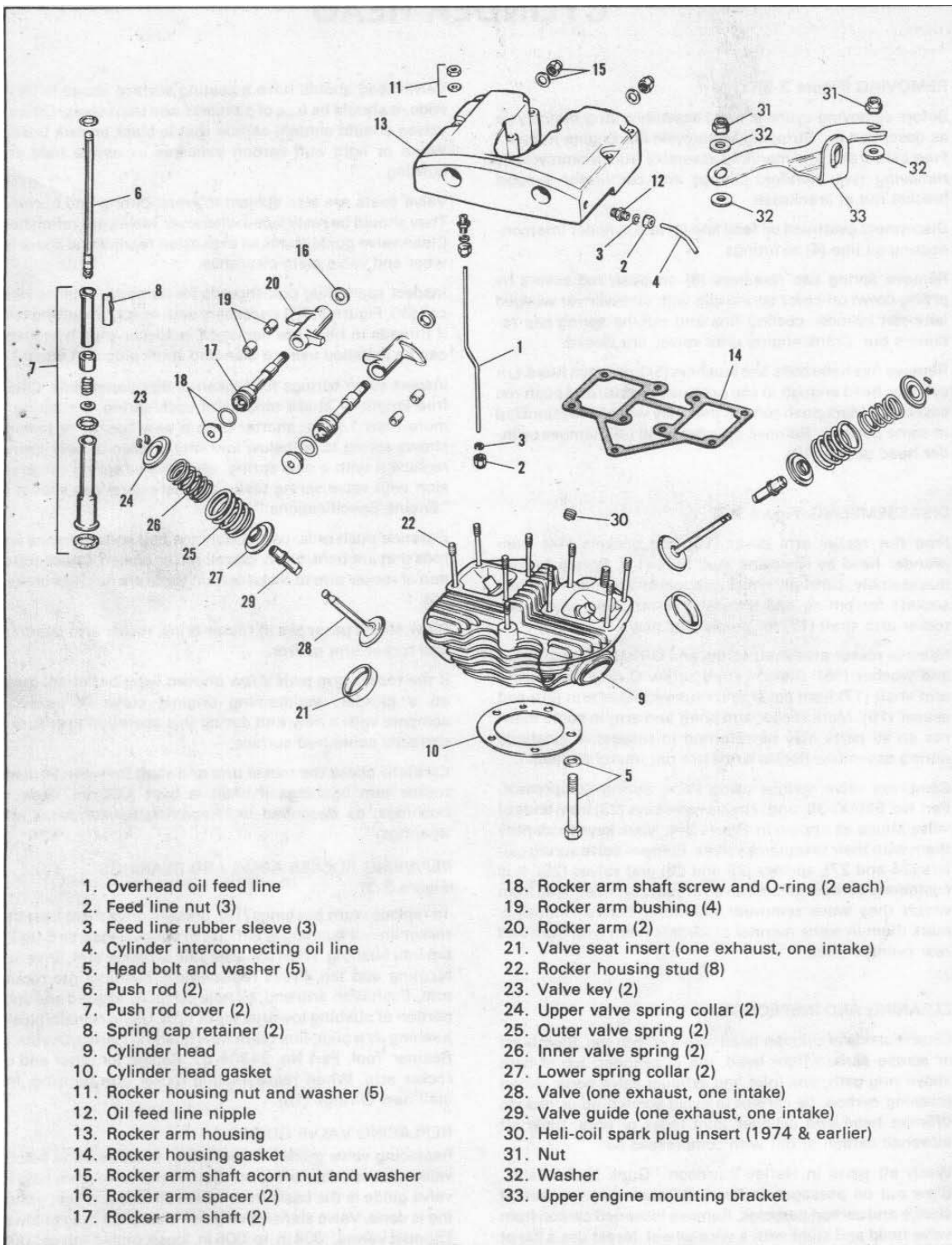

Figure 3-3. Cylinder Head - Exploded View

Tap out valve guides with shouldered drift pin (from chamber side) and insert replacement guide on arbor press. Be particularly careful to press replacement guide squarely into hole.

New valve guides are reamed to correct size. However, when guides are pressed into cylinder heads, they may close up slightly; also the ends may be burred. Therefore, after new guides are in place, they should be sized and cleaned with an expansion reamer.

It is of prime importance that valve guides fit tightly in cylinder heads, or valves may not seat properly. If original guide or new standard guide is not a tight press fit, an oversize guide must be installed. Oversize guides can be obtained .001 in. to .008 in. oversize. The number of grooves on O.D. indicates number of thousandths of an inch press diameter is oversize.

RECONDITIONING OR REPLACING VALVE SEATS

After installing valve guides, valve seats must be refaced to true them with guides.

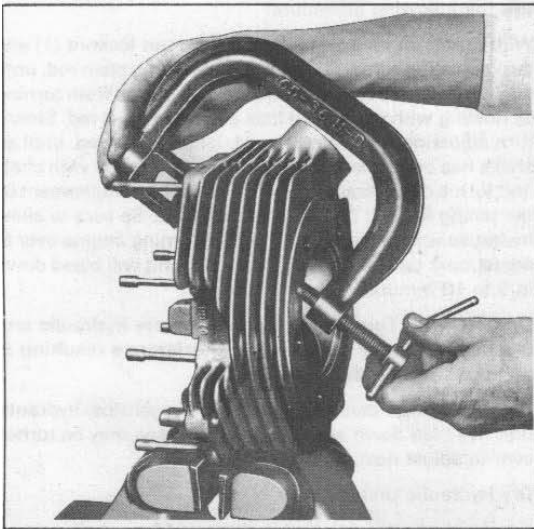

Figure 3-4. Compressing Valve Spring

If valves have been resealed several times, valve seats may have become too wide and/or valve may be seating itself too deeply in head. When valve seat becomes wider than 1/16 in. (see Figure 3-5) valve seat relief must be counter-bored or ground to reduce seat to 1/16 in. Counterbore dimensions are shown. Tools for this purpose are available commercially. To determine if valve is seating itself too deeply in head, measure distance from shoulder of valve guide to end of valve stem. See dimension in Figure 3-5. When valve stem extends through guide excess of maximum shown valve seat inserts must be replaced.

A special gauge is available under Part No. 96490-59A which is used to measure this dimension. The tool consists of gauge valves and gauge which is placed over the valve stem as shown. If top end of gauge valve stem is between steps on gauge, the valve seat location is satisfactory.

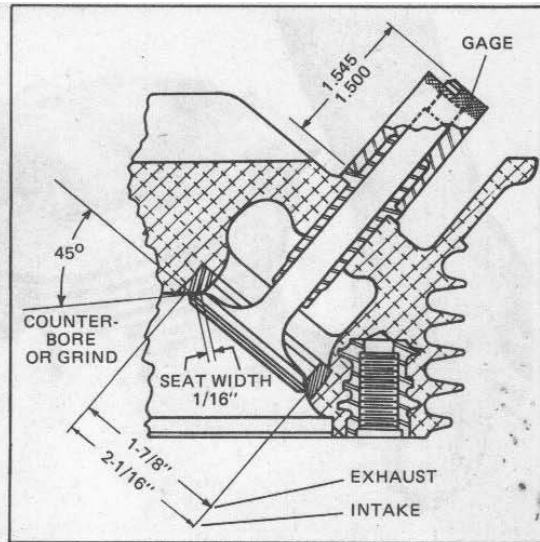

Figure 3-5. Valve Seat

Replacement inserts are available from the factory. Installation requires accurate boring equipment to machine correct counterbore in head for installation with .004 to .006 in. interference fit.

GRINDING VALVE FACES AND SEATS

Valve seat tools and fixtures are available commercially. Seat each valve in same port from which it was disassembled.

Valve face angle is 45° for both intake and exhaust valves, and if a valve refacing grinder is used, it must be adjusted exactly to this angle. It is important to not remove any more metal than is necessary to clean up and true valve face. If grinding leaves the edge of valve very thin or sharp, install a new valve. A valve in this condition does not seat normally, will burn easily and may cause pre-ignition. There is also danger of cracking. Valves that do not clean up quickly are probably warped or too deeply pitted to be used. If end of valve stem shows uneven wear, true end of stem on a valve refacing grinder equipped with suitable attachment.

Intake valves are marked "IN" on head; exhaust valves are marked "EX."

LAPPING VALVE FACES AND SEATS

If valve faces and seats have been smoothly and accurately refaced, very little lapping will be required to complete seating operation. Apply a light coat of fine lapping compound to valve face, insert valve in guide and give it a few oscillations with Valve Grinding Tool, Part No. 96550-36. Lift valve and rotate it about 1/3 of a turn. Repeat lapping procedure as shown in Figure 3-6. After full turn, remove valve, wash valve face and seat, and dry with cloth that is immediately discarded so grinding compound cannot be transferred to engine parts. If inspection shows an unbroken lapped finish of uniform width around both valve and seat, valve is well seated. If lapped finish is not complete, further lapping, or grinding and lapping is necessary.

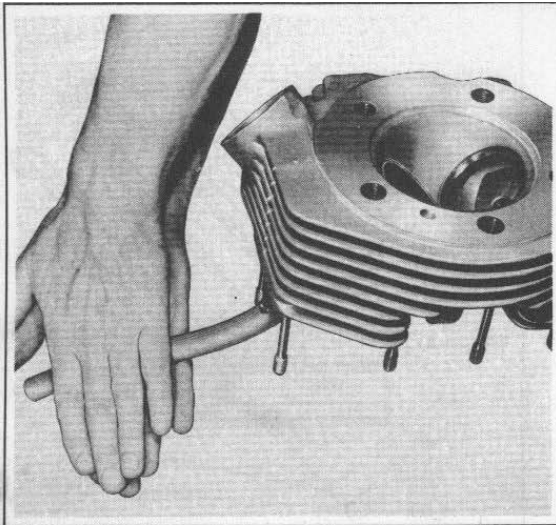

Figure 3-6. Lapping Valves

ASSEMBLING CYLINDER HEAD

Replace valve and valve spring assemblies using Valve Spring Compressor, Part No. 96600-36. Position valve keys so spaces between key halves are equal. Spaces between key halves must face front and rear of engine on intake valves.

Replace rocker arm assemblies. Rocker arms must be free or hydraulic lifters will not fill with oil.

Replace rocker arm cover. New cover gaskets (14) should be used and cover nuts (11) tightened evenly to 15 ft-lbs.

IMPORTANT

Be sure to see that rocker arm ends do not jam against valve stems as rocker box is installed on head studs. Use a screwdriver to raise valve end of arm when cover assembly is installed.

Install new cylinder head to cylinder gasket and position rear head. Start cylinder head bolts. Turn engine until front cylinder exhaust tappet is just starting upward. Install rear cylinder exhaust push rod and push rod cover. Make certain both push rod ends are properly seated in rocker arm and tappet.

Rotate engine until front cylinder intake tappet is just starting upward. Install rear cylinder intake push rod in same manner as exhaust push rod. Tighten head bolts evenly to ensure a proper seal. First turn bolts snug, then using a torque wrench tighten each 1/4 turn at a time until all are drawn to 65 ft-lbs.

Repeat procedure to install front cylinder head.

ADJUSTING TAPPETS (Figure 3-7)

When adjusting tappets, the engine must be cold and push rod must be at its lowest position (valve closed). Lowest position may be found by rotating engine until like tappet (intake or exhaust) in other cylinder is at highest point (valve fully open). Tappets can be adjusted under wet or dry conditions.

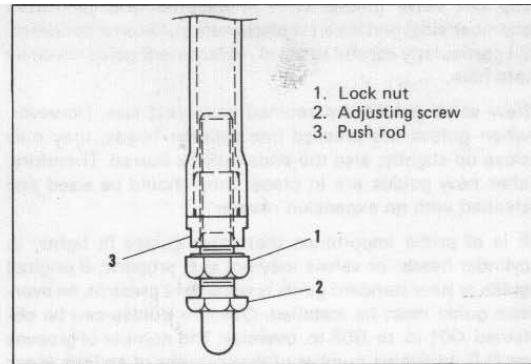

Figure 3-7. Adjusting Tappets

Wet Hydraulic Unit

If the push rod hydraulic unit is under oil supply conditions, that is, has not been removed from the engine and cleaned, use the following procedure:

With tappet in its lowest position, loosen locknut (1) and turn adjusting screw (2) upward, shortening push rod, until push rod has noticeable shake. Keep push rod from turning by holding with wrench on flats at base of push rod. Slowly turn adjusting screw downward, lengthening rod, until all shake has been taken up. Mark adjusting screw with chalk and turn it down exactly four full turns. Lock adjustment by tightening locknut (1) to 10 ft-lbs torque. Be sure to allow hydraulic unit to bleed down before turning engine over to adjust next tappet. Usually, hydraulic unit will bleed down in 5 to 10 minutes.

CAUTION — Turning engine over before hydraulic unit bleeds down may cause valve interference resulting in damaged push rods or valves.

When push rod can be rotated with finger tips, hydraulic unit has bled down sufficiently and engine may be turned over to adjust next tappet.

Dry Hydraulic Unit

If hydraulic unit is dry, that is clean and free of oil, set tappet at its lowest point before inserting dry hydraulic unit.

Install push rod and turn adjusting screw (2) downward until hydraulic unit piston bottoms in its bore. Turn adjusting screw (2) upward exactly 1-3/4 turns. Lock adjustment by tightening locknut (1) to 10 ft-lbs torque. When using this method, bleed down is not required before proceeding to next tappet.

Turn engine over until next tappet is at its lowest point before inserting next dry hydraulic unit. Adjust push rod length as described above. Continue in this manner until all tappets are adjusted. Make sure hydraulic unit is clean and dry before adjusting push rod length.

Install push rod cover spring cap retainers.

Always use new push rod cover gaskets at all joints. Clean gasket surfaces with greaseless solvent. Greasy gaskets or surfaces will cause gaskets to adhere to joint surfaces and become difficult to remove without damaging joint surfaces.

CYLINDER AND PISTON

DISASSEMBLING CYLINDER AND PISTON (Figure 3-8)

Strip motorcycle as described in "Stripping Motorcycle for Engine Repair."

Remove cylinder head as described in "Disassembling Cylinder Head."

Remove all cylinder base stud nuts and washers (1) except one on rear cylinder using Cylinder Base Nut Wrench, Part No. 94585-30. Raise front cylinder and piston enough to permit placing a cloth over crankcase opening. This will prevent dirt or pieces of broken ring from falling into crankcase.

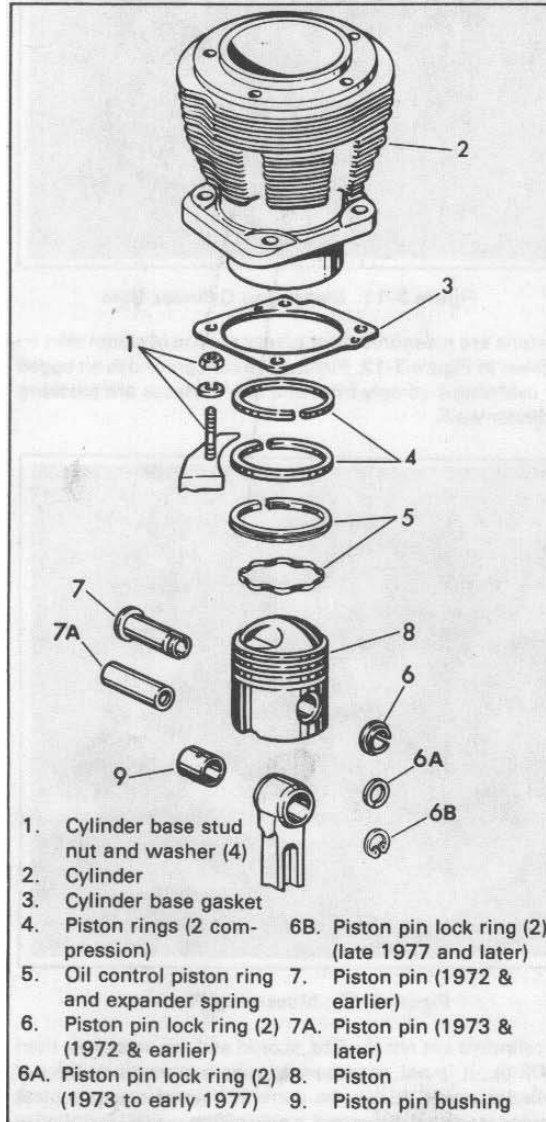

Figure 3-8. Cylinder - Exploded View

With piston at bottom of stroke, remove cylinder (2). Remove remaining stud nut from rear cylinder. Remove rear cylinder in same manner. Discard cylinder to crankcase gasket (3).

Spring piston rings (4) outward until they clear ring grooves in piston and lift off. Use a commercial ring expander if necessary. On 1972 and earlier models, pry right piston pin lock ring (6) off piston pin using the Piston Lock Ring Tool, Part No. 96780-32A and screwdriver as shown in Figure 3-9. Right end of piston pin has slots for this purpose. On 1973 to early 1977 models, pry piston pin lock rings (6A) from piston groove using two sharp pointed instruments such as awls. On late 1977 and later models use Internal Lock Ring Pliers, Part No. 96215-49 to remove lock rings. Support piston and tap out piston pin (7A) with a suitable drift.

CAUTION — Do not use retaining ring, Part No. 22588-78, in early style pistons, it will fit too loose. Use only in late style pistons marked with the number "7" or "77" on top.

Remove piston pin bushing (9) if necessary (see "Cleaning and Inspecting"), using Piston Pin Bushing Tool, Part No. 95970-32A.



Figure 3-9. Removing Piston Pin Lock Ring (1972 and Earlier)

CLEANING AND INSPECTING

Place cylinders and pistons in "Gunk Hydro-Seal" or other carbon and gum dissolving agent until deposits are soft. Scrub piston dome and outside of cylinder to remove deposits. Where carbon deposit is thick and hard, it is advisable to scrape carbon before cleaning. Use a putty knife or ground tip on an old file. Use care to keep from scraping into aluminum of piston.

Wash all parts in solvent and blow dry with compressed air. Force air through feed and return oil passages in cylinder. Clean piston ring grooves with a piece of compression ring ground to a chisel shape.

Examine piston pin to see that it is not pitted or scored. Check the piston pin bushing to see that it is not loose in connecting rod, grooved, pitted or scored. A piston pin, properly fitted, is a light hand press fit in piston and has .001 in. clearance in connecting rod upper bearing. If piston pin to bushing free fit exceeds .002 in., replace worn parts, (see "Connecting Rod Bushings").

If piston pin is to be used again, examine lock ring on unslotted end of pin. If ring is tight in its groove it is not necessary to remove it. When a new ring is required, clean ring groove and install ring before pin is installed in piston. The piston pin included with new piston assembly will have lock ring already installed on unslotted end.

Examine piston and cylinder for cracks, burrs, burned spots, grooves and gouges.

Check rods for up and down play on lower bearings. See Figure 3-10. When up and down play is detected and male rod has more than $3/64$ in. side shake at extreme upper end and female rod has $1/64$ in. side shake at extreme upper end, lower bearing should be refitted. This requires removing and disassembling engine crankcase.

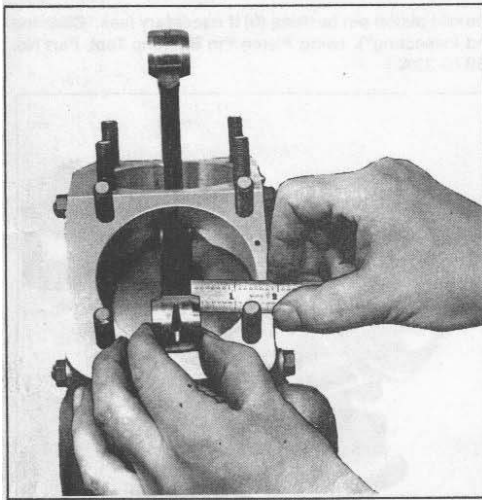

Figure 3-10. Checking Connecting Rod Fit

REFINISHING CYLINDERS

Gauge pistons and cylinders to see if they are worn to the point where cylinders must be rebored and oversize pistons installed. Inside and outside micrometers used for piston to cylinder fitting should be checked together to be sure they are adjusted to read exactly the same. Subtract piston measurement from bore measurement to obtain clearance. Bore measurement of a cylinder should be taken in ring path, starting about $1/2$ in. from the top of cylinder, measuring front to rear then side to side. Repeat procedure at the center and at the bottom of ring travel (see Figure 3-11). This process will determine if cylinder is out of round or "egged" and will also show any cylinder taper or bulge.

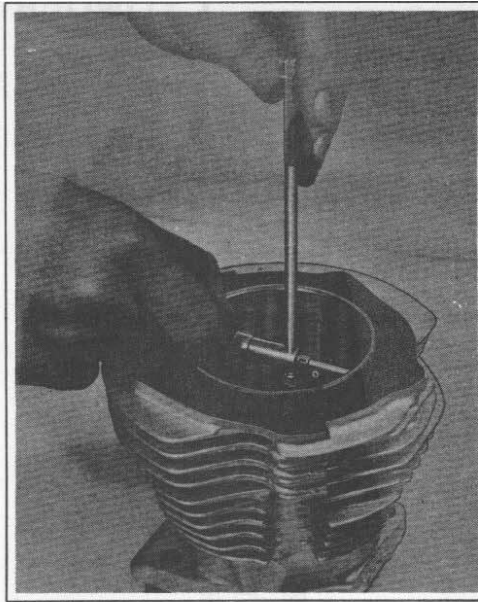

Figure 3-11. Measuring Cylinder Bore

Pistons are measured front to rear at base of piston skirt as shown in Figure 3-12. Pistons are cam ground to an egged or oval shape so only front and rear surfaces are touching cylinder wall.

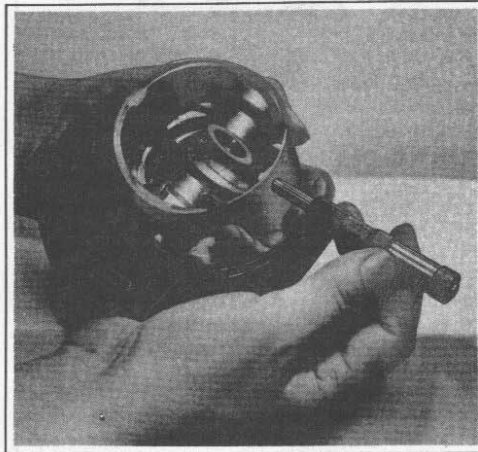

Figure 3-12. Measuring Piston

If cylinders are not scuffed, scored and are worn less than .002 in., it is not necessary to reboresize at time of cylinder repair. It may be done at time of next complete engine overhaul. If desired, a new piston may be installed to reduce clearance for more quiet operation.

If cylinders show more than .002 in. wear, they should be rebored and/or honed to next standard oversize and refitted with corresponding pistons and rings.

Pistons are regularly supplied in the following oversizes: .010, .020, .030, .040, .050, .060 and .070 in. Oversize pistons have their oversize stamped on head; 10, 20, etc.

Cylinders can be refinished oversize with a hone only, or with a boring bar followed by a finishing hone. In general practice only cylinders not scored and not badly worn are refinished entirely with a hone. Cylinders badly worn or deeply scored are first rebored to nearly the required oversize and then are finish-honed to exact size. Exact final size of the cylinder bore is determined by size of the piston to be used in that cylinder. Measure piston diameter accurately as described previously, then add desired piston clearance in cylinder. This will equal the exact final size to which cylinder bore should be refinished, example: the .020 in. oversize piston to be used measures 3.4575 in., adding .001 in. (desired clearance) equals 3.4585 in. (finish-honed size). When cylinders require reboring to beyond .070 in. oversize to clean up, their oversize limit has been exceeded and the cylinders must be replaced.

When cylinders are worn less than the .022 in. maximum, and reboring is unnecessary, unless they are scuffed or grooved the same pistons may be used with the replacement of rings and the roughing of cylinder walls to facilitate ring seating. Use No. 150 carborundum emery cloth to rough walls.

FITTING PISTON RINGS

Piston rings are of two types – compression (plain face) and oil control ring. The two compression rings are positioned in the two upper piston ring grooves with the stamped word "TOP" or a dot (.) upward. Rings are regularly supplied in the following oversizes to fit standard oversize pistons: .010, .020, .030, .040, .050, .060 and .070 in.

Compression rings must have proper side clearance in ring grooves. Check with thickness gauge as shown in Figure 3-13. Ring gap (space between ends) must also be as specified, see "Specifications," Section 3.

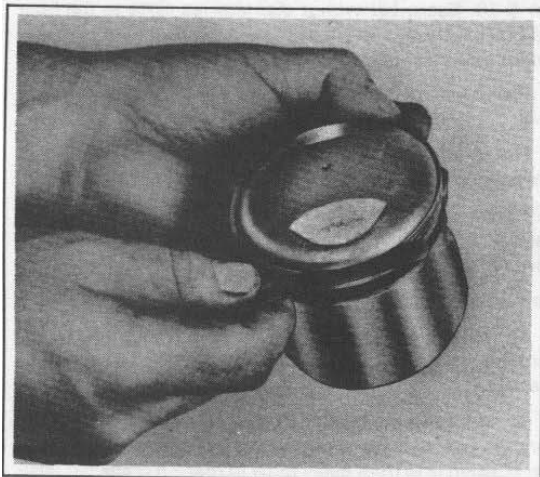

Figure 3-13. Measuring Ring Side Clearance

The oil ring is a full width slotted oil control ring using a spring expander.

To check ring gap, place a piston in cylinder with top end of piston about 1/2 in. from top of cylinder. Place ring in cylinder bore squarely against piston and check gap with thickness gauge (see Figure 3-14).

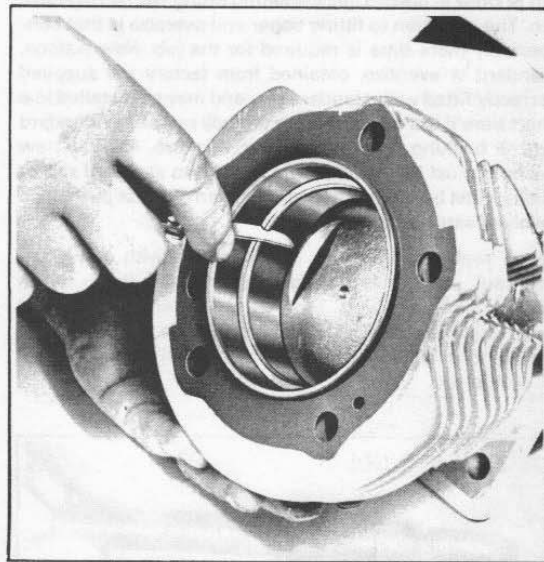

Figure 3-14. Checking Ring Gap

Use only standard size rings and piston in standard bore, and only matching oversize rings and piston in the same oversize bore.

If gap is less than specified, ring ends may butt under expansion, and be scored or broken. Compression ring gap may be increased by filing with fine-cut file.

Use a commercially available piston ring expander (Figure 3-15) to guide and slip rings over the piston into their respective grooves without over expanding or twisting rings and damaging the finely finished piston surface.



Figure 3-15. Assembling Rings with Ring Expander

CONNECTING ROD BUSHING

When connecting rod bushing is tight in rod but is worn to excessive pin clearance (.002 in. or more) it is possible to service by reaming oversize and fitting an oversize pin. However, it is recommended that a new bushing be installed and reamed to fit a standard pin, except when piston to be used had previously been fitted with oversize pin, or pin is loose in bosses, necessitating fitting with an oversize pin. The objection to fitting upper end oversize is that considerably more time is required for the job. New pistons, standard or oversize, obtained from factory are supplied correctly fitted with standard pin, and may be installed in a short time if the rod bushing is already reamed to standard size. If bushing has been reamed oversize, either a new bushing must be installed and reamed to standard size or piston must be reamed oversize to fit an oversize pin, which involves extra time.

When replacing bushings in connection with only a top overhaul, use Harley-Davidson special tools as shown in Figure 3-16, Bushing Tool, Part No. 95970-32A and Connecting Rod Clamping Fixture, Part No. 95952-33. Be careful to start new bushing with oil slot in alignment with oil slot in rod.

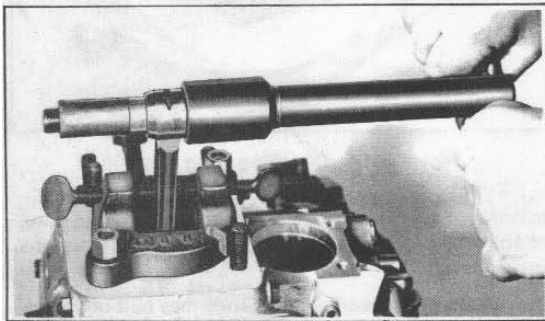

Figure 3-16. Replacing Rod Bushing

Ream new bushing to size with Special Reamer, part No. 94800-26. A properly fitted pin should have .001 in. clearance; with this clearance, pin will have just noticeable shake in bushing. Fitting tighter is likely to result in a seized pin or bushing loosened in rod. A .004 in. oversize pin is available for use with worn bushing. Ream old bushing to correct size for oversize pin.

STRAIGHTENING CONNECTING RODS

In refitting and reassembling connecting rods, and finally fitting pistons, rods may be bent or twisted, throwing upper bearing and lower bearing out of alignment with each other.

After pistons have been installed, rods must be checked and realigned as necessary. If a rod is bent or twisted, piston has a "cocked" relation to cylinder bore and the result is excessive noise and rapid wear.

Check rod alignment with Piston Squaring Plate, Part No. 96179-18, as shown in Figure 3-17. Be sure crankcase face is clean and free from burrs so that squaring plate seats fully.

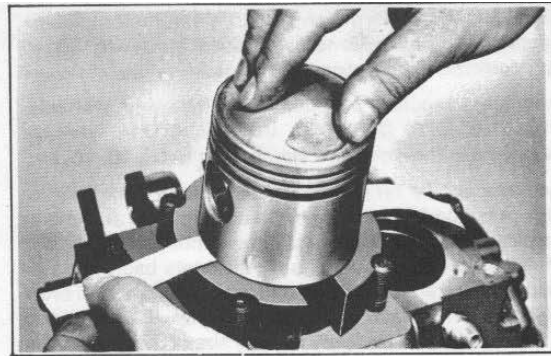

Figure 3-17. Checking Rod Alignment

NOTE

Piston skirt is cut away at bottom (below piston pin) for flywheel clearance, therefore, it cannot be used with squaring plate for checking rod alignment. Temporarily install special piston with flat bottom skirt, Part No. 96180-76, to check rod alignment.

If a rod is in perfect alignment piston bottom will rest squarely on plate when flywheels are turned so that crank pin is in forward and rear position. This check, to be accurate, depends upon checking with crank pin alternately in both forward and rear positions. It is the change of rod angle, resulting from changing crank pin from one position to the other that influences the seat of piston on squaring plate and thus indicates whether or not rod is in alignment.

Insert narrow strips of paper of equal thickness underneath piston, one on each side, below piston pin, as shown in Figure 3-17. Press piston down lightly with finger tips resting on center of piston head and pull first one paper, then the other, partially from underneath piston. If piston is perfectly square (rod in alignment), both will have the same amount of drag.

If rod proves to be out of alignment, it can be straightened by means of a bar inserted through piston pin, as shown in Figure 3-18. Use a bar with a diameter as close to the hole diameter in the piston pin as possible. The manner in which piston seats on squaring plate indicates as follows:

1. Piston high on same side, both crank pin positions; rod is bent.
2. Piston high on opposite sides as crank pin position is changed; rod is twisted.
3. Piston square or nearly square with crank pin in one position and high on one side with crank pin in other position; rod is bent and twisted.

Correct as follows:

1. To straighten a bent rod, insert straightening bar through piston pin hole on low side of piston and apply upward force.
2. To straighten a twisted rod, insert straightening bar through piston pin hole on high side of piston, and if crank pin position is to front apply force to rear - if crank pin position is to the rear apply force to front.

3. To straighten a bent and twisted rod (combination of a bend and twist) remove bend first and then remove twist. After rods have been aligned check to see that pistons center in crankcase cylinder opening, without side pressure on upper rod ends. If further realigning is necessary to center pistons, correct by dressing off end of rod bushing on interfering side with a file. This allows the piston to shift slightly on rod to find a more suitable alignment of rod, piston, and cylinder bore.



Figure 3-18. Straightening Connecting Rod

ASSEMBLING CYLINDER AND PISTON

Attach piston to connecting rod with a piston pin. Position piston so lug on piston pin boss inside piston skirt is to right side of engine. See Figure 3-19.

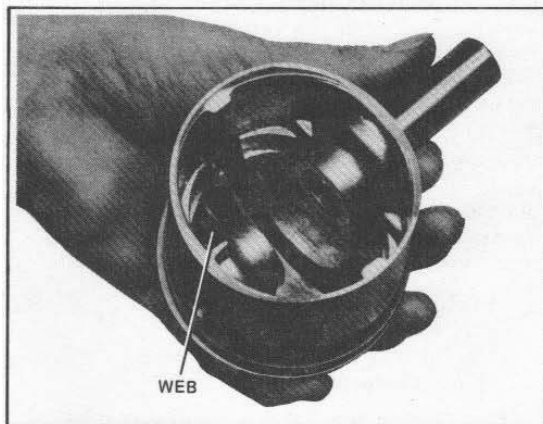

Figure 3-19. Piston with Web on Right Side

1972 and earlier models: Clean lock ring groove and install lock ring on end of pin that is not slotted if it was removed. Start slotted end of pin into piston boss from left side and drive through in the same manner in which pin was removed.

If the piston is heated in boiling water, the pin may be inserted into piston as a slip fit.

After pin is in place, clean lock ring groove and install the other lock ring (see Figure 3-20). It is important that special Lock Ring Tool, Part No. 96780-32A be used for installing lock rings on 1972 and earlier models. Use Lock Ring Tool, Part No. 96280-58A on 1973 to early 1977 models. On later 1977 and later models, use Lock Ring Pliers, Part No. 96215-49.

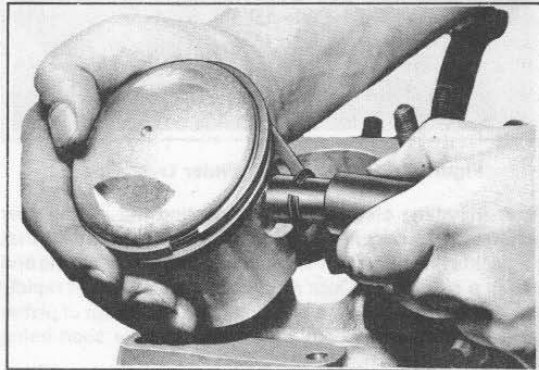

Figure 3-20. Inserting Piston Pin Lock Ring (1973 to Early 1977)

NOTE

Lock ring is expanded just enough to go over end of pin. Other means of installing may over-expand ring and possibly crack it. Make sure ring groove is clean and that ring seats firmly in groove.

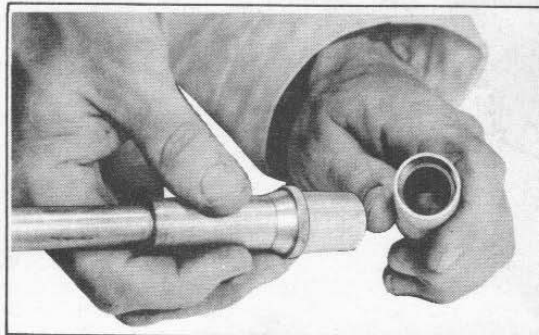

Figure 3-21. Inserting Piston Pin Lock Ring in Tool (1973 to Early 1977)

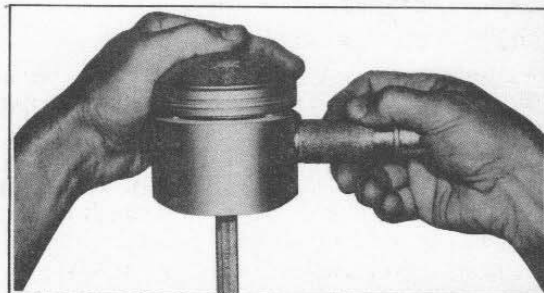

Figure 3-22. Installing Piston Pin Lock Ring (1973 to Early 1977)

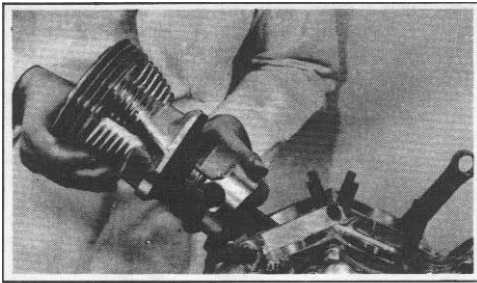

Figure 3-23. Slipping Cylinder Over Piston

After installing piston pin to connecting rod, install new piston pin lock ring. Make sure ring groove is clean and that ring seats firmly in groove. If it doesn't, discard the ring and install a new one. A lock ring loosely installed will rapidly loosen further in service and finally will come out of piston groove, resulting in both piston and cylinder soon being damaged beyond repair.

Never install a used lock ring or a new one if it has been installed and then removed for any reason, always use a new lock ring.

Lubricate cylinder walls, pistons, pins and rod bushings with engine oil. Rotate rings until gaps are equidistant around rear piston. Turn engine until crank pin is at bottom center. Install new cylinder base gasket. Position Piston Inserter Ring Tool, Part No. 96333-51A on rear piston and slip rear cylinder down over piston as shown in Figure 3-19.

Install lockwashers and nuts and pull them down evenly. Tighten nuts to 32-36 ft-lbs torque. Repeat process to assemble front cylinder.

Assemble cylinder heads and remaining portions of motorcycle as indicated in "Assembling Cylinder Heads," and reverse order of "Stripping Motorcycle for Engine Repair."

GEARCASE

OIL PUMP

GENERAL

The oil feed pump and scavenger (oil return) pump are gear type pumps housed on one pump body and located on rear of gearcase on right side of motorcycle. The feed pump incorporates an automatic bypass valve that reroutes surplus oil (above the amount needed to lubricate the engine) directly to the gearcase or oil tank. A ball check valve is located ahead of the pressure regulating valve to prevent oil drainage from tank, and to operate the pressure switch.

Under normal operating conditions, the pump is a comparatively trouble free unit. The most common trouble with pump operation is the introduction into the pump of a metal or hard carbon chip. If either gets between the gear teeth, it is possible to shear a key, fracture a gear or break off a gear tooth.

If oil fails to return to the tank, check the scavenger pump gear drive shaft key. When the engine receives no

lubrication (oil remains in tank), the drive shaft key on the feed pump drive gear may be sheared. Both conditions together could be caused by shearing of the oil pump (gearcase) drive gear key. In cold weather slush ice formed from moisture condensation in oil may block oil passages and cause any of above troubles.

DISASSEMBLING (Figure 3-24)

The oil pump may be removed from the motorcycle as a unit after gearcase cover is removed. The oil pump may be disassembled, piece-by-piece without removing gearcase cover, with engine in chassis as follows:

Disconnect oil lines and oil pressure switch (1) from pump. Remove bolts and lockwashers (2) from gearcase studs, that hold oil pump cover in place. Remove oil pump cover (3) and gasket (4). Remove lock ring (5), drive gear (6), gear key (7) and idler gear (8). Remove two oil pump body mounting stud nuts (9) and slip pump body (10) off studs and gear drive shaft (11). Remove drive gear (12), key (13), and idler gear (14).

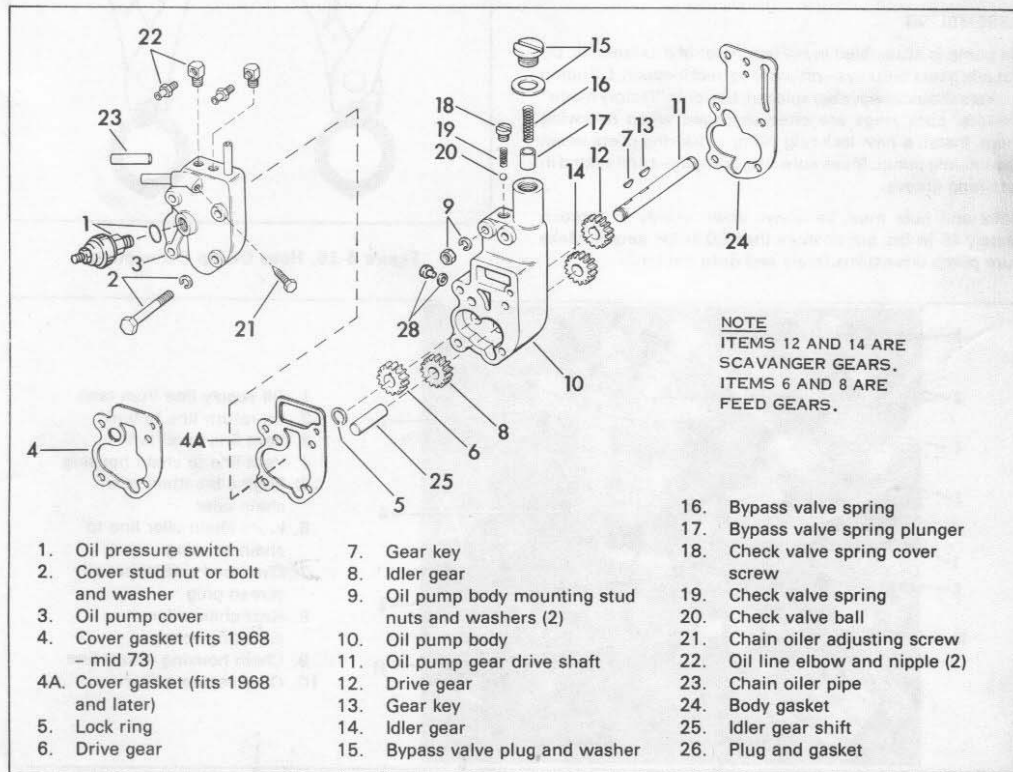

Figure 3-24. Oil Pump - Exploded View

Turn relief valve plug (15) out of pump body and remove relief valve spring (16) and valve (17). Remove check valve spring cover screw (18), valve spring (19) and ball (20). Turn in adjusting screw (21). Count the turns necessary to bottom screw then remove. Bottom and turn out same number of turns when assembling. Oil pump elbows (22) may be turned out of pump cover to facilitate cleaning.

To remove oil pump unit from gearcase with gearcase cover removed, remove ignition circuit breaker parts, gearcase cover screws, cover and gasket. (See "Gearcase Timing Gears".) Use a right angle lock ring pliers to remove lock ring from groove in pump drive gear shaft and remove drive gear and key. Remove pump body nuts and bolts (2 and 9) and slip pump with drive shaft (11) out of gearcase. Pump is then disassembled as above.

CLEANING AND INSPECTING

Thoroughly clean all parts in cleaning solvent and blow pump body passages clear with compressed air. Inspect valves and valve seats for pitting and wear. Replace pump having worn or damaged valve seat. Inspect keys and keyways. Inspect scavenger and feed pump gear teeth for gouging or cracking caused by foreign materials going through pump. Pump shafts and bushings normally last lifetime of engine.

ASSEMBLING

Oil pump is assembled in reverse order of disassembly. Do not mix gears and keys - return to correct location. Oil pump gaskets should always be replaced. Use only "factory made" gaskets. Lock rings are often damaged when removing them. Install a new lock ring using a lock ring pliers when assembling pump. Make sure ring is engaged and seated in retaining groove.

Bolts and nuts must be drawn down evenly to approximately 45 in-lbs, but no more than 50 in-lbs torque. Make sure pump drive turns freely and does not bind.

This is important because the oil pump cover gasket and body gasket are made from plastic material. If overtightened, the plastic material will be squeezed out of place and eliminate pump gear side clearance which may seize and damage the pump parts.

If a leakage problem exists, disassemble pump and inspect all gasket surfaces making sure they are flat and smooth. Install new gaskets and reassemble pump, tightening four bolts and two nuts evenly to 45 to 50 in-lbs torque.

Oil hose connections have one piece band type clamps and must be replaced each time hoses are connected. Use Hose Clamp Tool, Part No. 97087-65 to squeeze clamps tight as shown in Figure 3-25.

NOTE

Certain changes were made to the oil pump during the 1973 model season requiring different parts. As an aid in identifying parts for proper assembly, consult service Bulletin No. 647.

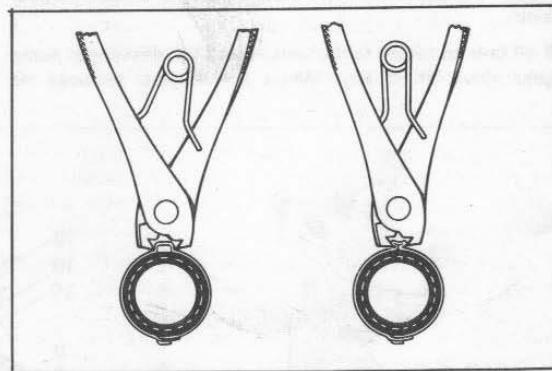
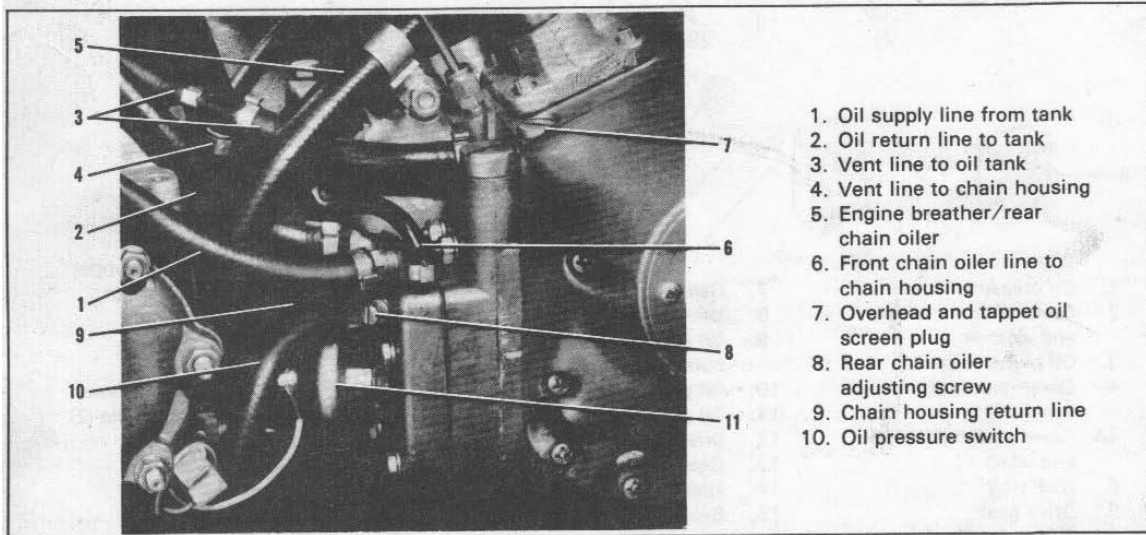

Figure 3-25. Hose Clamp Connection



1. Oil supply line from tank
2. Oil return line to tank
3. Vent line to oil tank
4. Vent line to chain housing
5. Engine breather/rear chain oiler
6. Front chain oiler line to chain housing
7. Overhead and tappet oil screen plug
8. Rear chain oiler adjusting screw
9. Chain housing return line
10. Oil pressure switch

Figure 3-26. Oil Pump and Connecting Lines

VALVE TAPPETS AND GUIDES

GENERAL

The tappet assembly consists of tappet, roller and hydraulic unit. The tappet and roller, under compression force from valve spring, follow the surface of the revolving cam. The linear motion produced is transmitted to the valve stem by the hydraulic unit, push rod and rocker arm. The hydraulic unit contains a piston or plunger and cylinder plus a ball check valve which allow the unit to pump itself full of engine oil to take up all play in the entire valve train.

When hydraulic units are functioning properly the assembly operates with no tappet clearance. The units automatically compensate for heat expansion to maintain a no-clearance condition.

It is normal for tappets to click when engine is started after standing for some time. Hydraulic units have a definite "leak down" rate which permits the oil in the hydraulic unit cylinder to escape. This is necessary to allow units to compensate for various expansion conditions of parts and still maintain no-clearance operation. Hydraulic units are functioning properly if they become quiet after a few minutes of engine operation.

DISASSEMBLING TAPPETS (Figure 3-27)

If engine cylinder head is not disassembled, remove push rod cover spring cap retainer. Lift push rod covers and retract push rod adjusting screw until push rod may be lifted out of ball sockets.

Turn out tappet guide screws (1). Lift out hydraulic units (2). Loosen tappet guides by tapping gently with rawhide or soft metal hammer. Insert thumb and forefinger into push rod opening in tappet guide and press tops of tappets against side of guides.

Remove tappet and guide assembly. Be careful to avoid dropping a tappet through guide mounting hole and into gearcase. Slip push rod cover cork washers (3) out of top of tappet guide (4). Pull tappet and roller (5) out bottom of tappet guide and remove tappet guide gasket (6).

CLEANING AND INSPECTING

Wash all parts except hydraulic units and gaskets in grease solvent. Hydraulic unit parts are selectively fitted and may not be interchangeable so they must be individually and separately washed. Twist and pull hydraulic piston and spring from cylinder and wash parts.

Blow out oil passages in tappets, tappet guides and hydraulic units with compressed air. Insert a length of wire into oil channel openings in tappet guide to make sure passages are open. Air dry all parts.

Examine cams through tappet guide holes in gearcase for nicked, grooved or chipped condition. Examine tappet-guide matching surfaces for scuffing or grooving.

When tappet fit in guide exceeds maximum tolerance shown in "Engine Specifications" by .001 in. or more, replace worn parts. If roller is loose, force out pin on arbor press, insert new parts and peen or stake pin ends.

Check roller end clearance. Replace all units exceeding tolerances listed in specifications.

CHECKING HYDRAULIC UNITS (2, Figure 3-27)

Hydraulic units may be checked as follows: Wash and air dry piston and cylinder. Blow out cylinder from bottom to make sure ball and seat are dry. Insert piston in cylinder. Hold in an upright position without covering hole in bottom of cylinder. Press piston down until spring touches cylinder, then release the piston. If piston bounces back, unit is serviceable. If piston does not bounce back, cover hole in bottom of cylinder and repeat above process. If piston does not bounce back, unit is worn and must be replaced. If piston bounces back, ball is not seating, and unit should be replaced. Before replacing hydraulic units, check possibility of plugged or partially plugged screen under large capscrew located near rear tappet guide. Remove screen as described in "Disassembling Gearcase," and clean or replace if dirty.

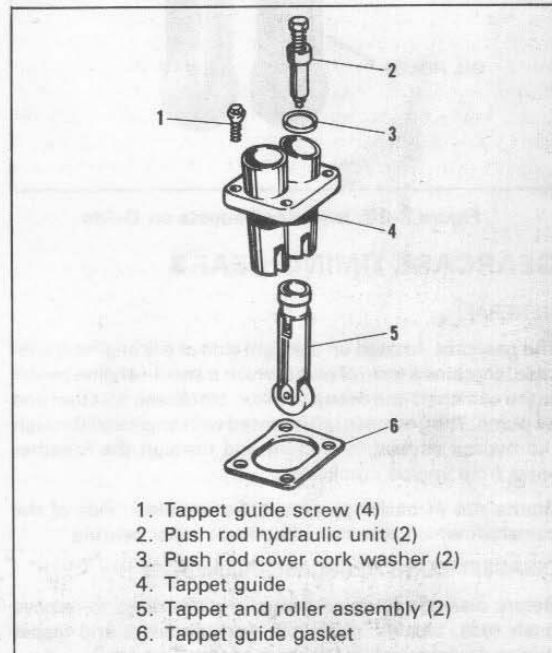

Figure 3-27. Tappet Assembly - Exploded View

ASSEMBLING TAPPETS (Figure 3-27)

Assemble tappets as follows: Slip tappets (5) into guide (4) so flat surfaces on tappets are toward center of guide as shown in Figure 3-28. If flat surfaces with holes are not toward center of guide, engine oil will not feed across and one hydraulic unit cannot fill with oil. Assemble tappet guide gasket dry and insert tappet assembly in place on gearcase, holding tappets in place with thumb and forefinger as when unit was removed.

Assemble push rod cover cork washers, push rod hydraulic units and tappet guide screws. Tighten tappet guide screws 10 ft-lbs torque.

Assemble remainder of push rod assembly in same order disassembled.

Adjust tappet clearance as described in "Cylinder Head."

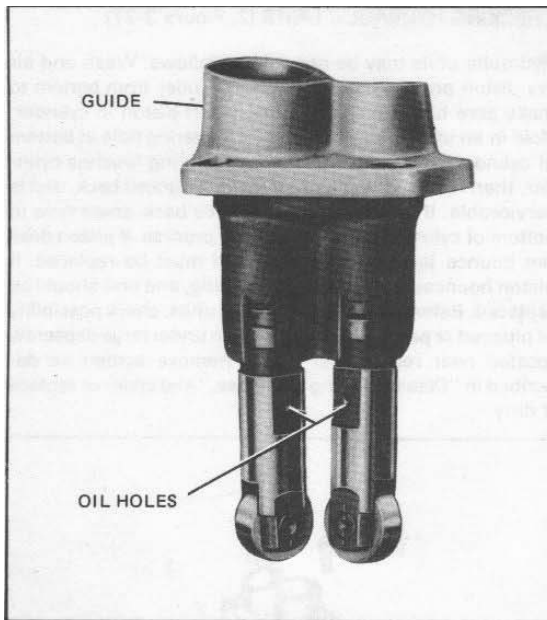

Figure 3-28. Inserting Tappets on Guide

GEARCASE TIMING GEARS

GENERAL

The gearcase, located on the right side of the engine crankcase, contains a train of gears which transmit engine power to the camshaft and circuit breaker, crankcase breather and oil pump. The gearcase is lubricated with engine oil through the bypass circulatory system and through the breather valve from engine crankcase.

Shafts run in bushings except the crankcase side of the camshaft which operates in a needle roller bearing.

DISASSEMBLING GEARCASE (Figure 3-29)

Before disassembling gearcase, it is advisable to remove push rods, tappets, push rod hydraulic units and tappet guides as described in "Disassembling Tappets."

1. Remove oil screen cap (1), O-ring (2), screen spring (3) and screen (4).
2. Remove two circuit breaker cover screws (5), cover (6) and gasket (7) from gearcase cover (17).
3. Remove circuit breaker cam assembly bolt (8). Remove screws (9, 9A or 9B), lockwashers and washers (10) or retainer (10A) and circuit breaker plate assembly (11).
4. Remove circuit breaker cam (12) and circuit breaker advance assembly (13)
5. Remove gearcase cover screws (14, 15 and 16).
6. Tap gearcase cover with wood or rawhide mallet to loosen and remove gear cover (17 or 17A) and gearcase cover gasket (18 or 18A). Note that 1973 and later parts are different than earlier parts and must not be interchanged.
7. Remove breather valve spacing washer (19) and breather gear (20).

8. Remove cam gear (21), spacing washer (22), and thrust washer (23).

9. Remove pinion gear shaft nut (24) which has a lefthand thread. Use Gear Shaft Nut Socket Wrench, Part No. 94555-55. Pull pinion gear (25) using Pinion Gear Puller and Installer, Part No. 96830-51 as shown in Figure 3-30. Tool has lefthand threads.

10. Remove key (26), gear shaft pinion spacer (27), oil pump pinion shaft gear (28) and key (29).

11. Use a lock ring pliers such as Snap-On No. PR129A, and remove oil pump drive gear shaft lock ring (30), drive gear (31) and drive gear key (32).

12. If necessary, remove oil pump stud nuts and washers and remove oil pump from gearcase. See "Disassembling Oil Pump."

CLEANING AND INSPECTING (Figure 3-29)

1. Wash and air-dry all parts. Wash inside of case. If crankcase is to be disassembled, wash parts after complete disassembly. If it is not to be repaired, be careful not to get any grease or solvent into crankcase when washing gearcase.

2. Inspect oil screen (4) carefully to make sure mesh is open. Holding screen to light is not an absolute check. It is possible for oil screen to be plugged or partially plugged with tiny lint-like fibers and still permit light to pass. Replace plugged or partially plugged screen.

3. Inspect cam gear and pinion gear bushings (33 and 34) in gearcase cover for pitting, scuffing and grooving. Determine amount of pinion and camshaft wear in cover bushings. If it exceeds maximum tolerance shown in "Engine Specifications," by .001 in., install new bushings.

4. Inspect cam gear oil seal (35) in cover to see that lip is in good condition.

5. Attach dial indicator to gearcase cover mounting screw hole and determine amount of pinion shaft play in right main roller bearing. When tolerance in "Engine Specifications" is exceeded by .001 in., bearings should be replaced.

6. Inspect needle bearing (36) for wear, broken or gouged bearings. If end of camshaft shows any appreciable wear (.003 in. or more), needle bearing is probably worn to a point where replacement of bearing and camshaft are advisable.

7. Needle bearing can be removed and installed in crankcase without disassembling crankcase with Puller Tool, Part No. 95760-69 as shown in Figure 3-34. Press needle roller bearing into crankcase with Tool, Part No. 97272-60 as shown in Figure 3-34. Press from heavier end having the manufacturer's name only. Pressing from opposite end will crush roller race and bind rollers. Pinion shaft main roller bearing may be replaced only when crankcase is disassembled (see "Disassembling Crankcase.")

8. Inspect gears for wear. Assemble pinion and cam gear to respective positions in gearcase. Omit cam gear end spacer in assembly for purposes of this check and attach cover with at least three cover screws. Mesh is considered ideal when no play between gears can be felt and cam gear can be moved back and forth along shaft axis without restriction.

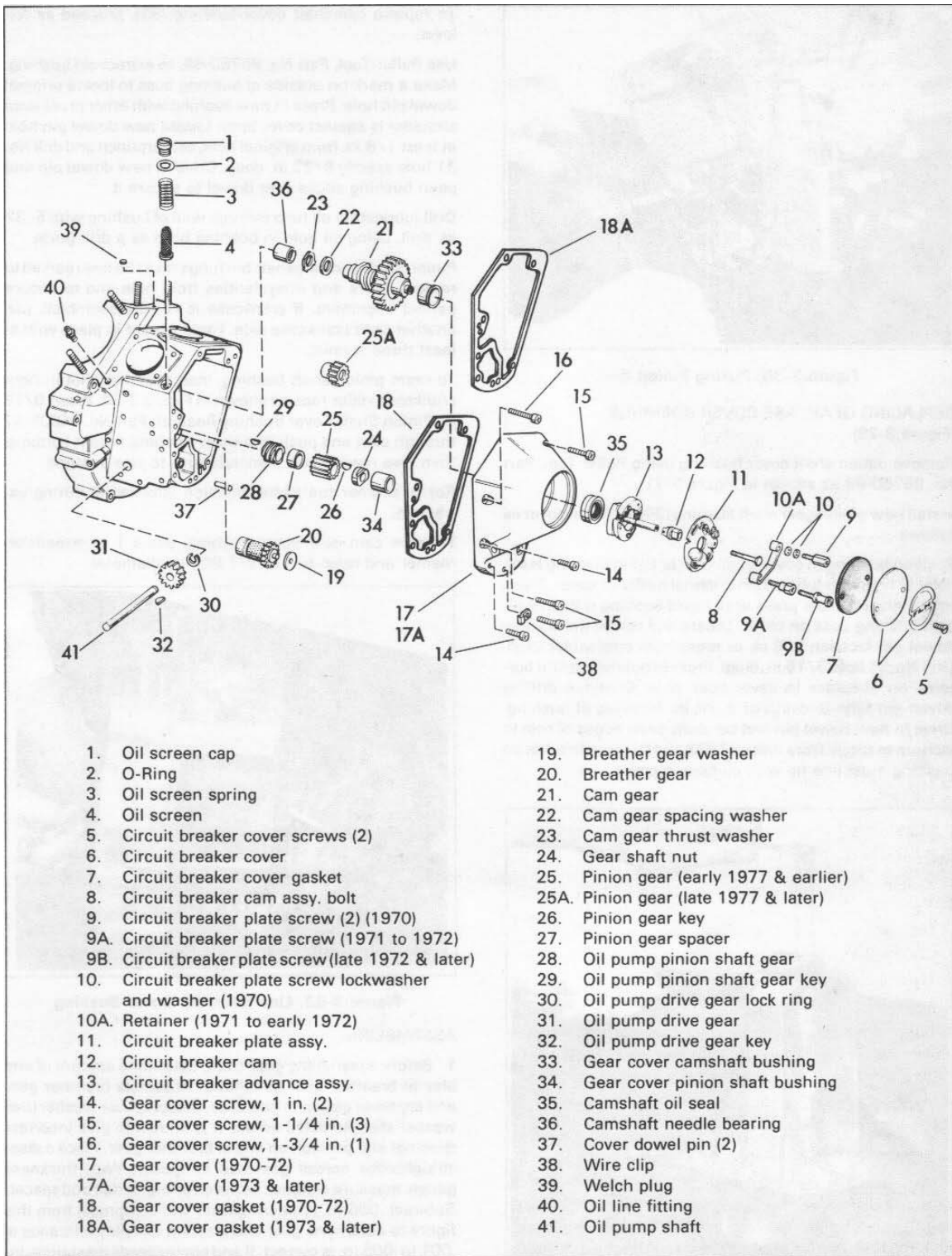

Figure 3-29. Gearcase - Exploded View

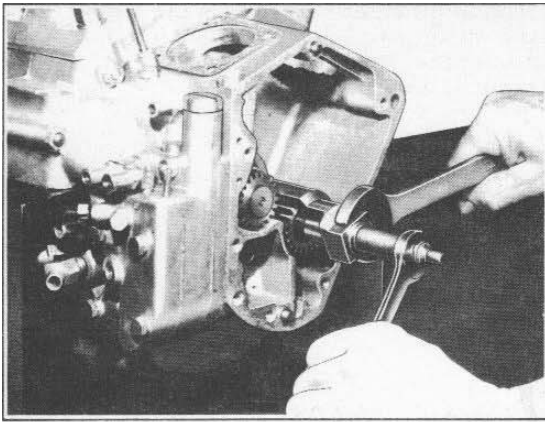

Figure 3-30. Pulling Pinion Gear

REPLACING GEARCASE COVER BUSHINGS (Figure 3-29)

Remove pinion shaft cover bushing using Puller Tool, Part No. 95760-69 as shown in Figure 3-31.

Install new pinion gear shaft bushing (34) in hole in cover as follows:

Position bushing in cover so oil hole or flat in bushing is exactly in line with lubrication channel outlet in cover. Press in bushing on arbor press until top of bushing is flush with cast bushing boss on cover. Locate and center punch new dowel pin location 1/8 in. or more from original location. Drill No. 31 hole 3/16 in. deep. Press in bushing until it bottoms on shoulder in cover boss hole. Continue drilling dowel pin hole to depth of 9/32 in. from top of bushing. Drive in new dowel pin and carefully peen edges of hole to lock pin in place. Note that on 1973 and later models, flat on bushing must line up with oil hole in cover.

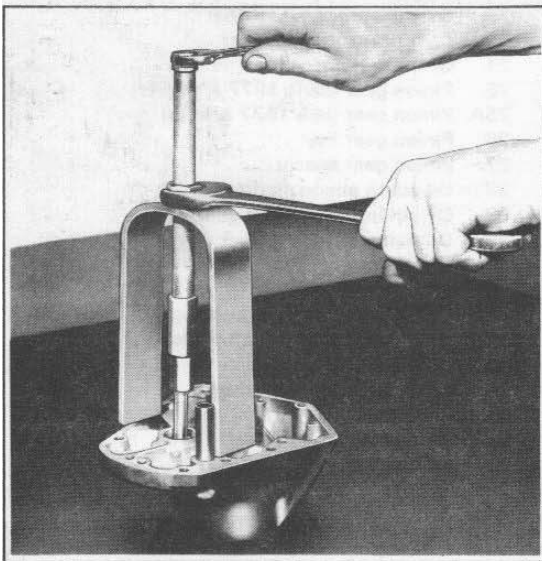

Figure 3-31. Removing Pinion Shaft Cover Bushing

To replace camshaft cover bushing (33), proceed as follows:

Use Puller Tool, Part No. 95760-69, to extract old bushing. Make a mark on outside of bushing boss to locate original dowel pin hole. Press in new bushing with arbor press until shoulder is against cover boss. Locate new dowel pin hole at least 1/8 in. from original hole, centerpunch and drill No. 31 hole exactly 9/32 in. deep. Drive in new dowel pin and peen bushing edges over dowel to secure it.

Drill lubrication oil hole through wall of bushing with 5/32 in. drill, using oil hole in bushing boss as a drill guide.

Pinion shaft and camshaft bushings must be line reamed to remove burrs and irregularities from hole and to ensure perfect alignment. If crankcase is not disassembled, use another right crankcase side. Fasten cover in place with at least three screws.

To ream pinion shaft bushing, insert reamer pilot in right crankcase roller race as shown in Figure 3-32. Insert 9/16 in. Pinion Shaft Cover Bushing Reamer, Part No. 94805-57 through pilot and push into cover bushing until it bottoms, then give reamer one complete turn to size bushing.

Rotate reamer the same direction (clockwise) during extraction.

To ream cam gear cover bushing, use a 1 in. expansion reamer and ream to 1.003/1.002 in. diameter.

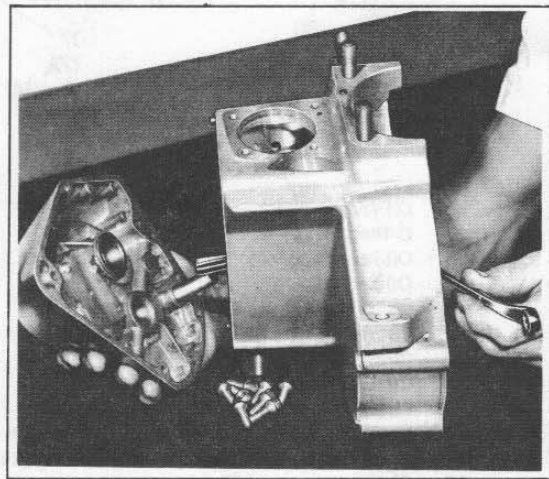

Figure 3-32. Line Reaming Cover Bushing

ASSEMBLING

1. Before assembling gear train, determine amount of end play in breather gear as follows: Assemble breather gear and dry cover gasket to gearcase. Select spacer washer (use washer disassembled unless it is known to give incorrect spacing) and position on end of breather gear. Place a steel straightedge across gearcase at spacer. With thickness gauge, measure distance between straightedge and spacer. Subtract .006 in. (amount gasket will compress) from this figure to determine gear end play. An end play tolerance of .001 to .005 in. is correct. If end play exceeds maximum, insert thicker spacer. Breather valve and gear spacer washers are available .110, .115, .120 and .125 in. thick.

2. Establish proper cam gear end play as follows: Install thrust washer, spacing washer and cam gear. Position cover gasket and secure cover with at least four screws. Measure camshaft end play between cam gear and cover bushing with thickness gauge through tappet guide hole in gearcase. End play should be from .001 to .005 in. If measurement is under or over tolerance, remove cover and replace spacing washer with one to give suitable clearance. Cam gear spacing washers are available .050, .055, .060, .065, .070 and .075 in. thick.

3. Make final gearcase assembly including all parts in approximate reverse of disassembly order. Make sure that chamfer on oil pump pinion shaft gear (28) is toward the inside. Tighten pinion gear shaft nut (24, Figure 3-29) to 35-45 ft-lbs and check to see that gearshaft pinion spacer has noticeable end play. Breather, cam and pinion gears contain timing marks which must be aligned or matched as shown in Figure 3-33. Rotate gear train and note if it revolves freely. A bind indicates gears are meshed too tightly.

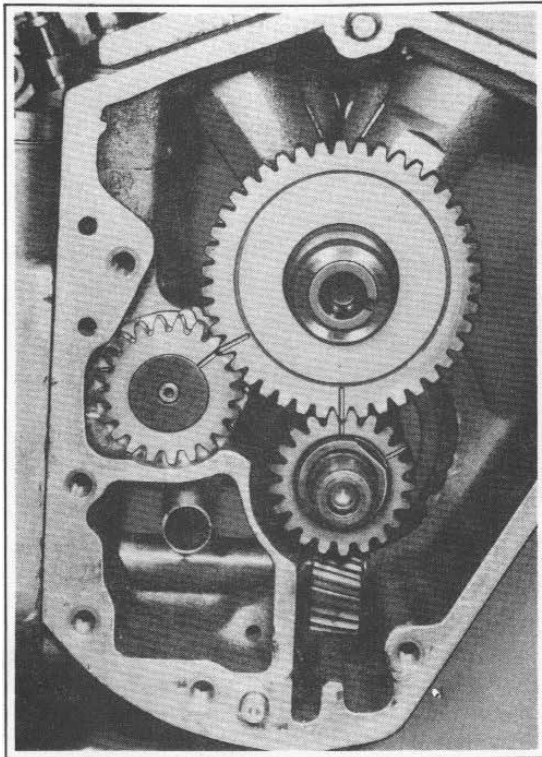

Figure 3-33. Timing Gears with Timing Marks Aligned

4. Apply a coat of non-hardening gasket sealer to crankcase and cover gasket surface. Position new cover gasket and secure cover with all cover screws. Pour about 1/4 pint of engine oil over gears to provide initial lubrication before securing cover.

5. Assemble remainder of gearcase, and circuit breaker in reverse of order removed. When assembling circuit breaker, set circuit breaker contact gap and ignition timing as described in "Circuit Breaker," Section 5.

NOTE

On late 1977 and later engines, the pitch diameter on the camshaft, pinion gear and breather valve gear was changed. These components are not interchangeable with earlier style components unless replaced in sets only. Late 1977 and later gear sets are identified by a circular groove machined in the outer face of the cam gear. Pinion and cam gears are color coded according to their pitch diameter. When replacing single gears, replacement gears should be matched according to the same color code. If gears are not matched, lifter noise or gear whine may result.

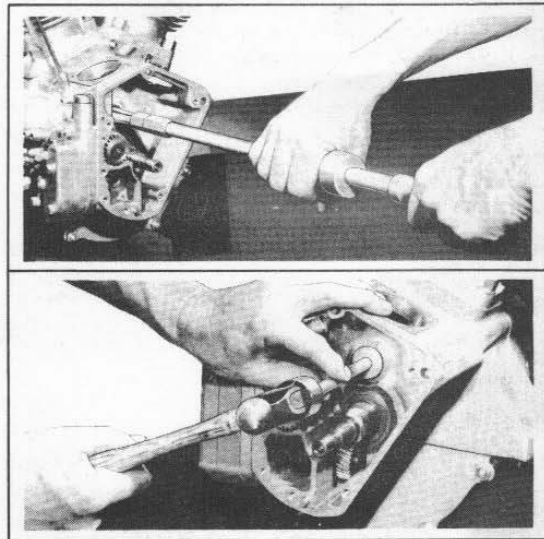

Figure 3-34. Removing and Installing Cam Gear Needle Bearing

CRANKCASE

GENERAL

When rod bearings, pinion shaft bearings or sprocket shaft bearings are in need of repair, the engine must be removed from the motorcycle as described in "Stripping Motorcycle for Engine Repair." It is recommended procedure to check and make repairs to cylinder heads, cylinders and gearcase at the same time, or in other words, perform an entire engine overhaul.

Flywheel End Play Check:

After engine has been removed from motorcycle and before removing crankcase bolts, assemble sprocket shaft bearing tool, Part No. 97225-55, tightly against bearing inner race (60 ft-lbs). Remove gear side cover, fasten dial indicator to gear side crankcase and place dial indicator stem on end of gear shaft. Securely fasten engine base to stand and workbench. Find flywheel end play in bearing by rotating tool while pushing, and pulling on tool, and reading dial indicator at extremes of travel. This operation is shown in Figure 3-51. If play exceeds .006 maximum allowable end play bearings must be replaced if found worn or damaged. If not worn, shimming can be used to take up end play as described on page 3-37.

The sprocket shaft bearing is locked in place with a combination lock ring spacer which is located in a groove between the two bearing outer races. If any part of the bearing set requires replacement the entire bearing assembly, including bearings, races, lock ring and inner race spacer, must be replaced as a set.

DISASSEMBLING CRANKCASE

1. Remove cylinder heads as described in "Disassembling Cylinder Head."

2. Remove cylinders as described in "Disassembling Cylinder and Piston."

3. Remove gearcase parts as described in "Disassembling Gearcase." Check flywheel end play as described above.

Refer to Figure 3-35 and proceed as follows:

4. Remove crankcase bolts (1) and studs (2, 3, 4 and 5). It is necessary to remove only one stud nut and slip stud and other nut out opposite side of crankcase.

Refer to Figure 3-36 and continue disassembly:

5. Position crankcase with gearcase (right side) up. Tap crankcase with rawhide or soft mallet to loosen top half. Lift right crankcase half (1) off pinion shaft main bearings. Remove spiral lock ring (2) from pinion shaft with tip of screwdriver. Lift bearing washers (3 and 5) with bearings and bearing retainers (4) off pinion shaft.

6. Mount flywheel and left case assembly on press table supporting case on parallel bars (Figure 3-38) and press on end of sprocket shaft with arbor press until flywheel assembly (8) drops out, freeing sprocket side bearing half (9), spacer (6) and spacer (10). Remove seal (7).

7. If left main bearing is to be replaced, tap out bearing races (11 and 13) from opposite sides of crankcase hole, using a brass drift and hammer. If bearing set is being replaced, remove lock ring spacer (12) using a 1/8 in. pin punch or similar tool. Rotate lock ring in groove so that one edge covers oil hole. Insert tool into oil hole with tapered end underneath lock ring. Tap on tool to force one end out of groove as shown in Figure 3-39. Starting at this free end, push ring out of bearing bore.

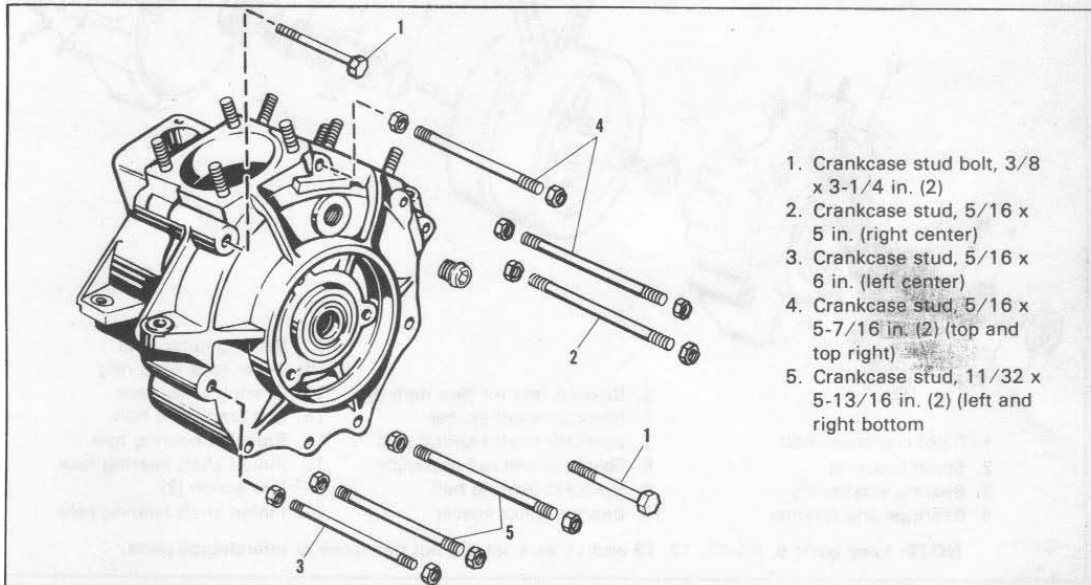

Figure 3-35. Crankcase Studs - Exploded View

1. Crankcase stud bolt, 3/8 x 3-1/4 in. (2)
2. Crankcase stud, 5/16 x 5 in. (right center)
3. Crankcase stud, 5/16 x 6 in. (left center)
4. Crankcase stud, 5/16 x 5-7/16 in. (2) (top and top right)
5. Crankcase stud, 11/32 x 5-13/16 in. (2) (left and right bottom)

WARNING — When removing lock ring (12), there is a possibility that it will spring from the groove with enough force to cause personal injury. To prevent this, wrap rag around crankcase and through lock ring.

8. If flywheels are to be disassembled, grip pinion shaft in vise and pull bearing from sprocket shaft using claw puller and wedge attachment. Place wedge halves behind bearing and pull bearing off by tightening puller screw against sprocket shaft center as shown in Figure 3-40. Keep bearings in a set with proper bearing outer races.

DISASSEMBLING FLYWHEELS (Figure 3-41)

1. Grip pinion shaft in copper covered vise jaws so shafts are in vertical position. Insert a rod about 5 in. long and 1/2 in. in diameter through holes in flywheels to keep them from turning. Remove lock plate screw (1), lock plate (2) and crank pin nut (3) with Flywheel Nut Wrench, Part No. 94546-41. Strike left flywheel with soft metal mallet at about 90 degrees from crank pin hole on wheel periphery to loosen. Lift left flywheel (4) off crankpin.

2. Hold down bearing assembly with a short length of pipe or tubing so connecting rods (5) may be slipped off bearings. Remove bearings (6). Hold together in set until bearings are washed and refitted to crank pin.

3. Remove lock plate screw (7), lock plate (8) and gear shaft nut (9). Tap pinion shaft (11) out of flywheel (10). Remove key (12) from shaft.

4. Clamp crank pin in vise. Remove lock plate screw (13), lock plate (14) and crank pin locknut (15). Tap crank pin (16) out of flywheel and remove key (17).

5. Grip sprocket shaft in vise and remove lock plate screw (18), lock plate (19) and sprocket shaft nut (20). Use Part No. 94546-41 Wrench for 1971 and earlier 1-5/16 in. hex nut. Use Snap-on Part No. S6202 Socket for 1972 and later 1-5/8 in. hex nut. Remove sprocket shaft (21) by tapping it out of flywheel, and remove key (22) where applicable.

CLEANING AND INSPECTING FLYWHEELS

1. Wash all parts in grease solvent and blow dry with compressed air. Examine crank pin for wear, grooving and pitting. If the surface is at all worn, replace with new pin. Examine flywheel washers (23 and 24). If either washer is worn and grooved, it should be replaced.

2. Examine connecting rod lower races. If they appear slightly grooved or shouldered where edge of bearing rollers ride, they may be lapped out and oversize bearing rollers installed. If they appear badly worn, grooved or pitted, new rods should be installed, preferably as an assembly with new bearings and crank pin.

3. Examine pinion shaft and right crankcase bearing race (see 17, Figure 3-36) for pitting, grooving and gouging at point where right main roller bearings ride. A shaft that is worn must be replaced. If bushing is worn beyond repair, replace as described in "Truing and Sizing Pinion Shaft Main Bearing."

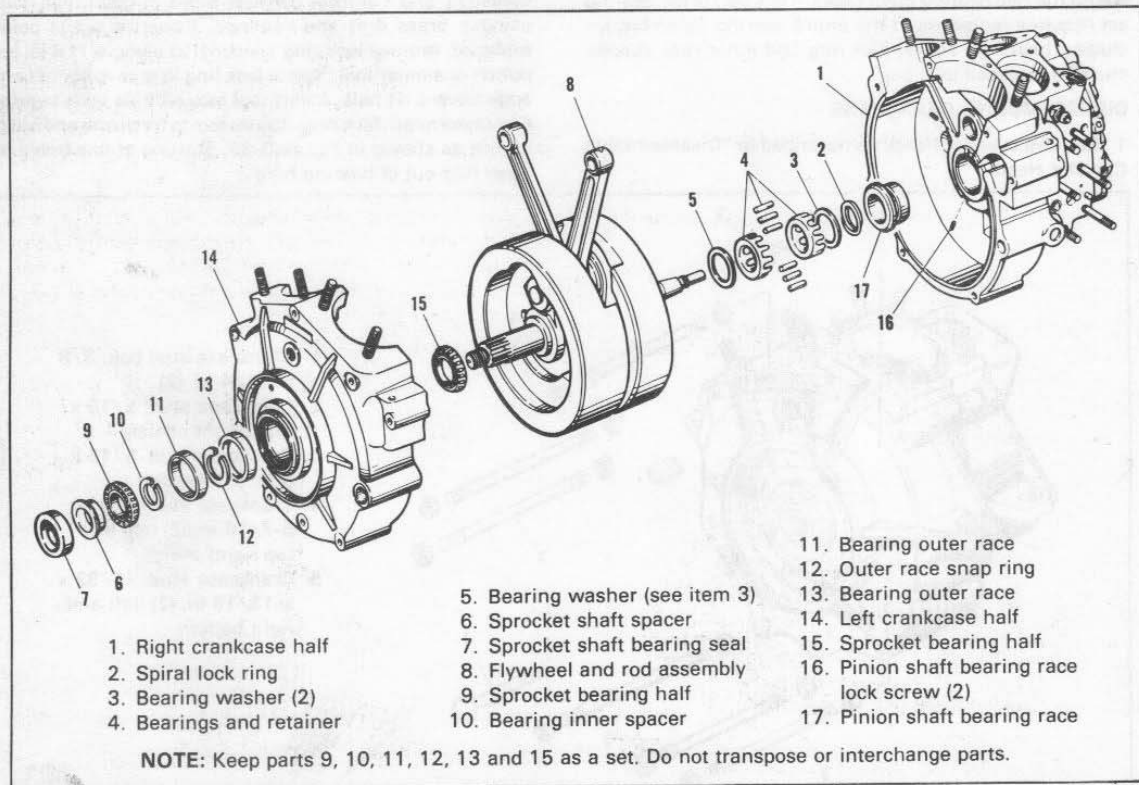

Figure 3-36. Crankcase - Exploded View

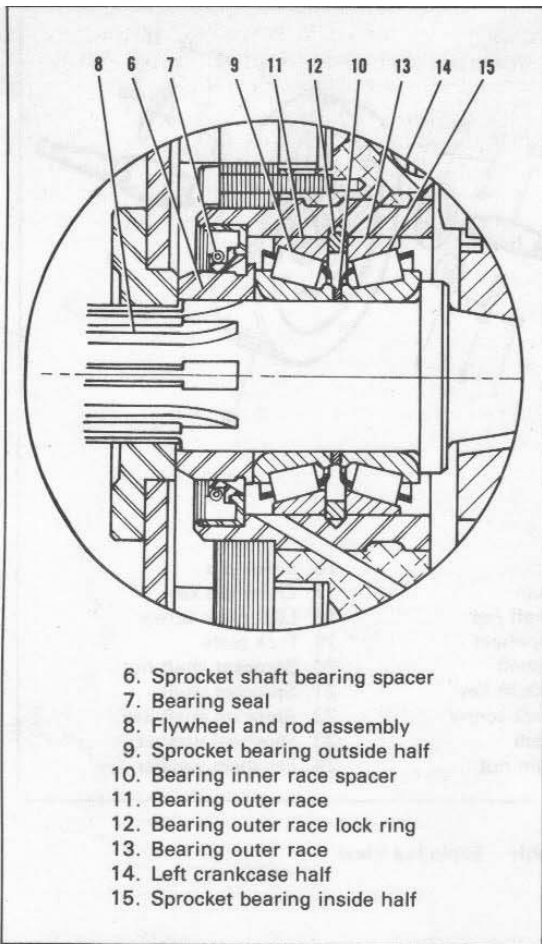

Figure 3-37. Sprocket Shaft Bearing Assembly - Section View

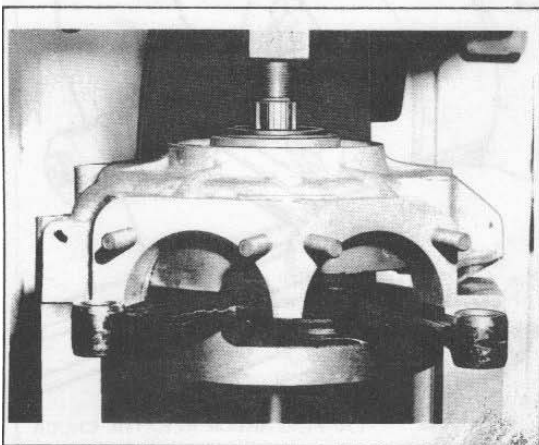

Figure 3-38. Pressing Flywheels Out of Crankcase

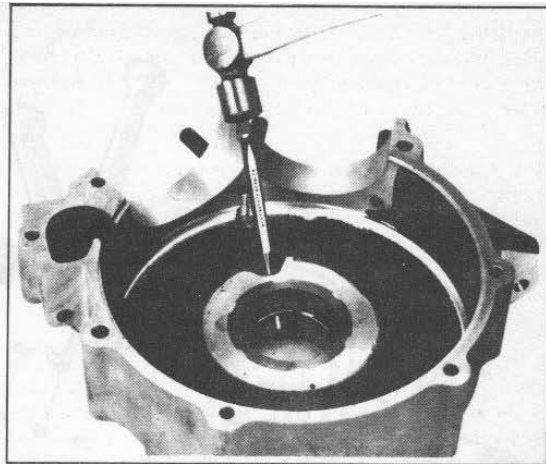

Figure 3-39. Removing Lock Ring

4. Examine sprocket shaft outer races for wear, grooving and pitting. Examine bearing rollers for wear, pitting, grooving and heat discoloration. The sprocket shaft Timken tapered roller bearings are manufactured in selectively fitted sets. The same serial number appears on all parts. If any part is unusable, the complete set must be replaced.

REPLACING FLYWHEEL WASHERS

Replace worn flywheel washers as follows:

1. Washer is a close fit in recess in flywheel and is secured originally by punching flywheel metal tight against the washer at several points. It is usually necessary to drill a small hole (1/8 in. or smaller) at the outer edge of the washer to permit getting a pointed tool underneath to pry it out. The hole is drilled out slightly deeper than the thickness of the washer to avoid removing more metal than necessary.

2. Before installing new washer, scrape outer edge of washer recess where metal was punched against it so new washer may seat fully against recess bottom. If washer does not seat fully, forked rod is not likely to have necessary clearance for side play.

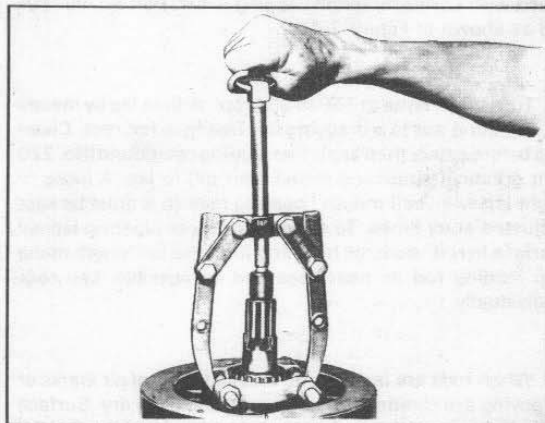

Figure 3-40. Pulling Bearing from Sprocket Shaft

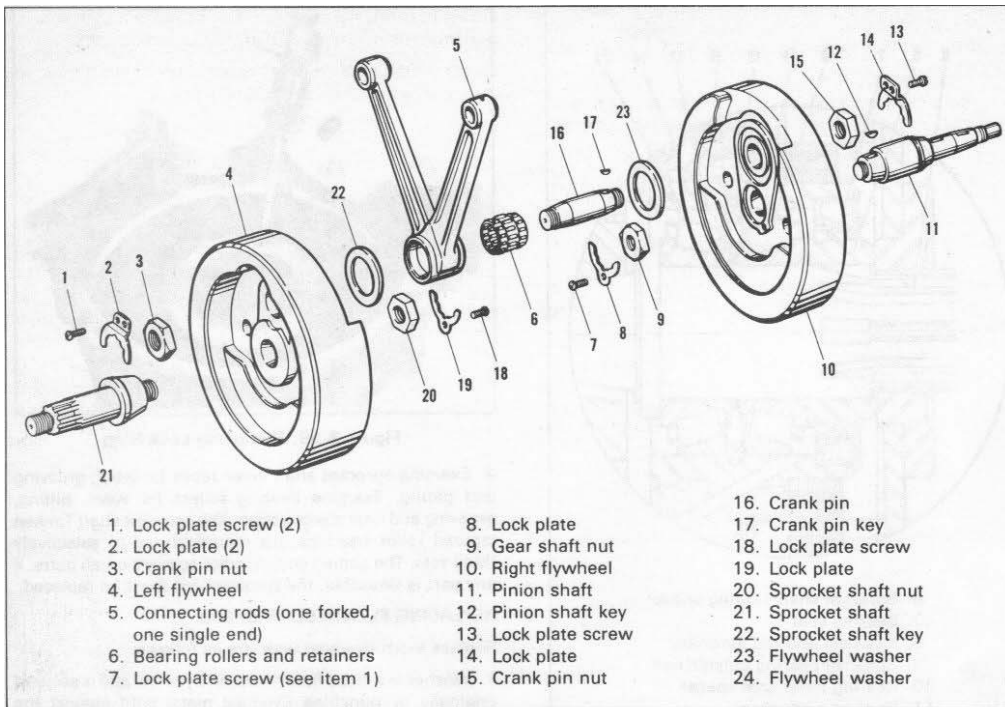

Figure 3-41. Flywheel Assembly - Exploded View

LAPPING CONNECTING ROD RACES

1. Connecting rod lower races that are likely to clean up within the range of oversize bearing rollers and are otherwise in serviceable condition, should be trued and sized with Connecting Rod Lapping Arbor, Part No. 96740-36 as shown in Figure 3-42.

2. Turn lap in lathe at 150 to 200 rpm. Adjust lap by means of adjusting nut to a dragging but free fit in rod race. Clean lap before using, then apply fine lapping compound (No. 220 grit grinding compound mixed with oil) to lap. A loose or right lap will "bell mouth" bearing race so it must be kept adjusted at all times. To avoid grooving or tapering lapped surface in rod, work rod back and forth the full length of the lap holding rod as near race end as possible. Lap rods individually.

3. When rods are lapped true and all traces of pit marks or grooving are cleaned up, wash rods and blow dry. Surface should have a soft velvety appearance and be free of shiny spots.

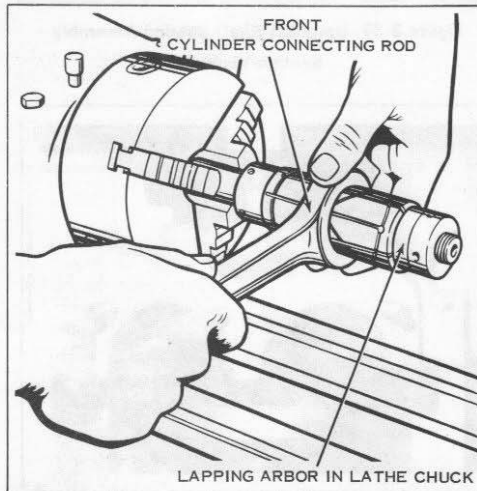

Figure 3-42. Lapping Connecting Rod Bearing Race

FITTING ROD BEARINGS

Oversize rollers are available in .0002, .0006, .0008 and .0010 in.

There are three ways to determine oversize rollers to use. All will result in properly fitted bearings if applied correctly.

1. Use a micrometer to measure the outside diameter of the crank pin at its center. Use an inside micrometer or telescoping hole gauge to measure the inside diameter of the rod races. Subtract the diameter of the crank pin from the inside diameter of the bearing race. Subtract from this figure the standard allowance for bearing running fit size. This answer, divided by two will give proper roller size. To find oversize amount of bearing, subtract from this figure the diameter of a standard roller.

Example:

The rod bearing race measure 1.6263 in. after lapping and truing. The crank pin is slightly worn and measures 1.2485 in. Subtract 1.2485 in from 1.6263 in. The answer, .3778 in., represents the diameters of both rollers (one on each side) plus clearance for running fit. Subtract minimum clearance for running fit (.001 in.). The answer (.3768 in.) is then divided by two to get the diameter of each oversize roller. In this case it would be .1884 in. To find how much oversize each roller must be, subtract from this figure the diameter of a standard roller, or .1875 in. Rollers must be .0009 in. oversize.

2. Install any new set of oversize rollers to bearing races and position on crank pin. Slip rods over bearings. If they will not fit, it is obvious rollers are too large and a smaller size must be tried. If they fit and spin freely, install a larger set of rollers. Try various roller sizes until the rods will turn with a very slight drag. This is a plug fit. Determining running fit is merely a matter of subtracting one half the desired running fit clearance (.0005 in.) from the roller size to find the running fit roller size.

It may be easier to gauge a plug fit as follows:

3. Fit any size rollers into races. Position bearings in rods. Support rods and bearings with left hand. Drop crank pin (not attached to flywheel) through crank pin hole. Plug fit has been achieved when crank pin will slide slowly through hole from its own weight. Running fit is then determined by subtracting one half running clearance from oversize of rollers used to make plug fit.

Example:

Plug fit is achieved with .0009 in. oversize rollers. By subtracting from this one half the minimum clearance (.0005 in.) it is determined that a .0004 in. oversize roller set will give desired running fit.

If lower end race of one rod is found to be slightly larger than the other, select rollers to fit the larger rod race and lap smaller rod race to same size as larger race rather than fitting rollers of two sizes.

When rods are correctly fitted with required bearing clearance, extreme upper end of female (forked) rod will have 1/64 in. side shake while the upper end of the male rod will have 3/64 in. side shake. All fitting and checking must be made with bearings, rods and crank pin clean and free of oil.

Fitting bearings tighter than described may result in seizing and bearing damage when heat expands parts.

Check overall width of roller retainer assembly. It must be less than width of female rod end.

ASSEMBLING FLYWHEELS (Figure 3-41)

1. After correct connecting rod bearing fit has been attained, clean and assemble parts as follows:

Wipe all tapers perfectly clean and free from oil. Install sprocket shaft (21) to left flywheel (4). For 1970 and 1971 models, make sure key (22) is in position. See "Engine Specifications" for proper torque. Assemble pinion shaft (11) and crank pin (16) to right flywheel making sure keys (12 and 17) are in proper position. Install lock plates (8 and 19). Tighten mounting screws (7 and 18) to 20-24 in-lbs torque. If corners of nuts do not align with notches in lock plate, tighten (do not loosen) shaft nuts to achieve alignment.

For 1972 and later models with 1-5/8 in. sprocket shaft nut, Snap-on Socket, Part No. IM-522 with Handle, Part No. L-52BH and a pipe extension is recommended to obtain 400 ft-lbs torque (4 ft x 100 lbs) required. To obtain maximum nut engagement, end of socket should be forced off in a lathe. Check to make sure oil passages through pinion shaft, right flywheel and crank pin are clear by blowing compressed air into hole near end of pinion shaft.

2. Position right flywheel assembly in vise, crank pin up. Wipe crank pin taper clean. Slip bearings and connecting rods over crank pin with forked rod to rear cylinder. Wipe crank pin hole in left flywheel clean and dry. Install left flywheel and tighten nut lightly. Hold steel straightedge along outer face of wheel rims at 90 degrees from crank pin as shown in Figure 3-43. Tap outer rim of top wheel until wheels are concentric. Tighten nut, recheck with straightedge at frequent intervals. Use soft metal hammer to realign wheels. To prevent flywheel assembly from turning in vise while tightening nut, insert a rod 5 in. long and about 1/2 in. in diameter through holes in flywheels and between vise jaws so that rod bears against some part of the vise.

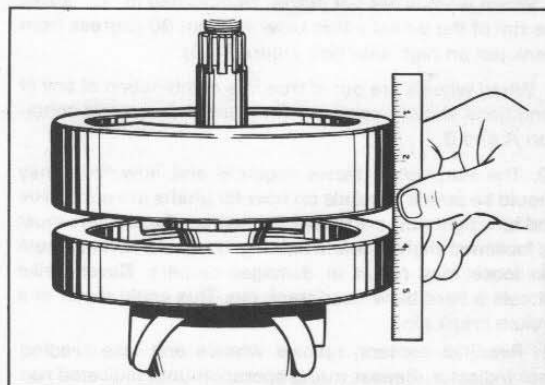

Figure 3-43. Squaring Flywheel Faces

3. When nut is fairly tight, install flywheel assembly in Flywheel Truing Device, Part No. 96650-30. Adjust so centers are snug. Wheels must turn freely but shafts may not be loose in centers. If flywheel assembly is either loose or squeezed, indicators will not indicate accurately. Adjust indicators to take reading as near to flywheels as possible, so pointers read at about the middle of the scales.

4. Turn flywheels slowly and observe the movement of indicator pointers. Movement toward flywheels indicate high points of shafts. Find highest point of each shaft and chalk-mark flywheel rims at those points. Loosen centers slightly, just enough so looseness may be detected, and make corrections as follows:

5. Flywheels may be out of true three ways, A, B and C, Figure 3-44 or a combination of two of the three ways.

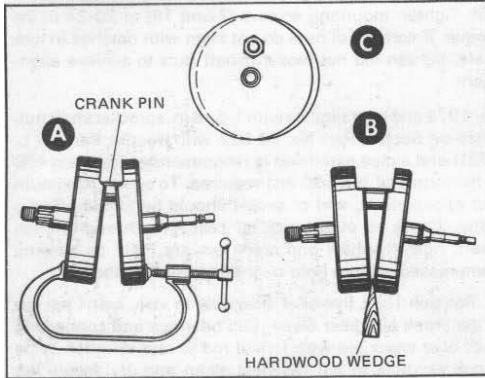

Figure 3-44. Correcting Flywheel Alignment

6. When wheels are both out of true as indicated in "A," tighten a C-clamp on rims of wheels opposite crank pin and lightly tap the rim at the crank pin with lead or copper mallet.

7. When wheels are both out of true as indicated in "B," drive a hardwood wedge between the wheels opposite the crank pin and lightly tap the rims near the crank pins with a mallet.

8. When wheels are out of true as indicated in "C," strike the rim of the wheel a firm blow at about 90 degrees from crank pin on high side (see Figure 3-45).

9. When wheels are out of true in a combination of any of conditions shown, correct C first, and then correct condition A and B.

10. The number of blows required and how hard they should be struck depends on how far shafts are out of true and how tight nuts are drawn. Remember that centers must be loosened slightly before striking flywheels. Making them too loose may result in damaged centers. Never strike wheels a hard blow near crank pin. This could result in a broken crank pin.

11. Readjust centers, revolve wheels and take reading from indicator. Repeat truing operation until indicated run out does not exceed .001 in. (each graduation on indicator is .002 in.).

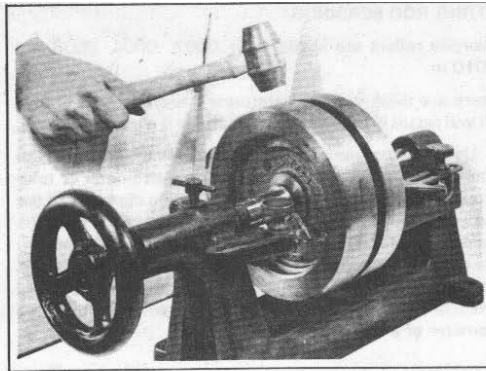

Figure 3-45. Truing Flywheels on Truing Stand

12. If it is impossible to true wheels, check for a cracked flywheel, damaged or enlarged tapered hole, or a sprocket or pinion shaft worn out-of-round at surface where indicator reading is being taken. When wheels are true, position in vise and draw crank pin nuts very tight using Crank Pin and Flywheel Nut Wrench, Part No. 94546-41, or use torque wrench and tighten to foot-pound reading given in "Engine Specifications." Check connecting rod side play with thickness gauge as shown in Figure 3-46. If it is greater than tolerance shown in "Engine Specifications," draw up crank pin nuts until within tolerance. Insufficient play between rods and flywheel face is caused by one of the following conditions:

- Flywheels and crank pin assembled with oil on tapers and nuts over-tightened. Disassemble, clean, reassemble.
- New flywheel washers installed and not fully seated. Disassemble, inspect, replace deepest seating flywheel or exchange crank pin. As last resort, grind down width of forked rod.
- Taper holes enlarged as a result of having been taken apart several times. Replace wheel seating deepest.
- Cracked flywheel at tapered hole. Replace flywheel.

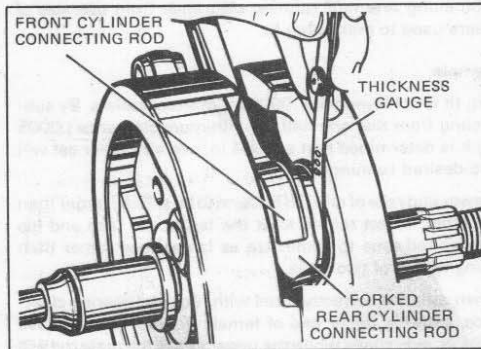

Figure 3-46. Checking Connecting Rod Sideplay

If sides of forked rod are ground to get desired clearance, backs of bearing retainers must be ground down to remain narrower than width of female rod.

After rod side play is checked and adjusted, crank pin nut tightened to specified torque, and lock plate and screw installed, again recheck wheel trueness on truing device. Correct any run-out as above.

TRUING AND SIZING PINION SHAFT MAIN BEARING

Before fitting new pinion shaft main bearings, lap bearing race in crankcase to true it and remove traces of wear shoulder at sides of roller paths. Using Crankcase Main Bearing Lap, Part No. 96710-40 consisting of lapping shaft, handle, lapping arbor and guide sleeve (Figure 3-47).

A race that is worn beyond limits of oversize bearings must be replaced. To remove worn bearing race, remove two bearing race lock screws (17, Figure 3-36) from inside of case. Heat case to 275-300 degrees F. Heating expands case and makes it possible to remove bearing race using less force. Press worn race (18, Figure 3-36) out and new race in. New race must be lapped slightly to true and align with left case bearing, and to attain a size compatible with roller sizes available.

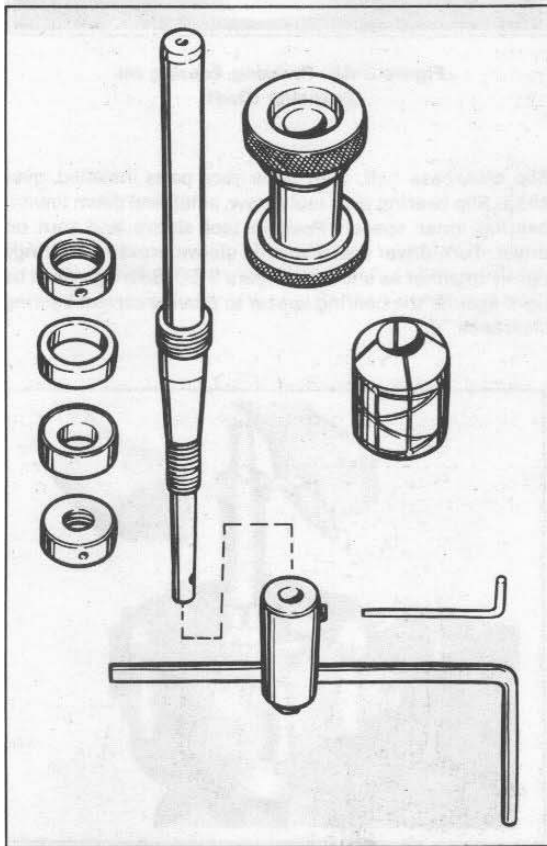

Figure 3-47. Main Bearing Lapping Tools

LAPPING ENGINE MAIN BEARINGS (Figure 3-48). Secure right and left crankcase halves with three crankcase stud bolts (top center and bottom left and right). The sprocket shaft bearing outer races and large spacer must be installed in left crankcase.

Assemble lapping arbor to lapping handle and assemble guide sleeve to sprocket shaft bearing bushing. Sleeves for use with tapered bearing, are assembled to case with bearings and small spacer collar. Turn sleeve parts finger tight.

Insert lap shaft with arbor assembled through pinion bearing bushing and into guide sleeve. Tighten arbor expansion collars using a length of 5/32 in. rod as spanner until arbor begins to drag. Do not adjust arbor snug in bushing or bushing will "bell," a condition where hole is larger at ends than it is in the center.

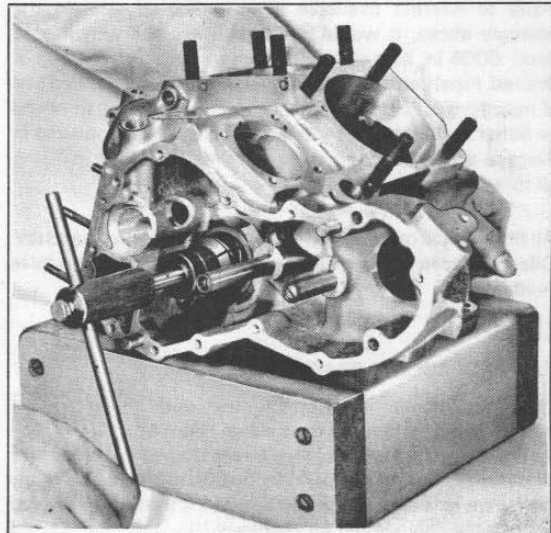

Figure 3-48. Lapping Pinion Shaft Main Bearing Race

Withdraw arbor far enough to coat lightly with fine lapping compound. Do not apply a heavy coat. Reposition lap in bushing and turn handle at moderate hand speed. Work lap back and forth in bushing as it is revolved to avoid grooving and tapering.

At frequent intervals, remove lap from crankcase, wash and inspect bushing. Lapping is completed when entire bushing surface has a dull, satin finish rather than a glossy, smooth appearance. If necessary, flush off lap in cleaning solvent, air dry and apply fresh, light coat of fine lapping compound.

FITTING PINION SHAFT BEARING

The fitting of pinion shaft bearing is done in much the same way as fitting lower rod bearings (see "Fitting Rod Bearings"). A plug fit is first determined using the pinion shaft that will be used on engine being overhauled, or spare shaft of exactly same size. When a plug fit has been found, pinion shaft will enter bearing slowly under its own weight, will turn with only a very light drag and will have no perceptible shake.

A running fit is determined from a plug fit by subtracting one half the desired running fit clearance from the size of the plug fit rollers.

Example:

Running fit clearance is .0005 to .001 in. loose. See "Engine Specifications," Section 3. If a plug fit was achieved with .0006 in. oversize rollers, subtract one half running fit clearance from plug fit roller oversize. Use figure representing middle or average of tolerance span, .00075 or .0008 in. One half the average of tolerance (.0004 in.), subtracted from roller oversize (.0006 in.), indicates that .0002 in. oversize rollers should be used to produce a suitable running fit.

Oversize rollers are available in .0002, .0004, .0006, .0008 and .001 in. sizes. All calculations should therefore be made to nearest available even-numbered size. In the example above, it would be possible to arbitrarily decide upon .0006 in. as a running fit rather than the .0008 in. if desired. Final decision would rest largely upon intended use of motorcycle. For high speed work, the more free fit would be better, while the closer tolerance is suited to road use at average speeds. This consideration may be made in fitting all tolerances.

All fitting must be done with bearings that are clean and dry. Oiled surfaces will take up some clearance and give a false reading.

FITTING SPROCKET BEARING

If flywheel end play is within tolerance and Timken tapered roller bearings and races pass visual check and have no apparent wear, the same set may be reinstalled. Make certain all parts of bearing are installed in exactly the same order they were removed. If any part of bearing assembly is worn, entire assembly should be replaced.

ASSEMBLING CRANKCASE (Figure 3-34)

Install flywheel side outer race snap ring (12) in case. When properly installed, oil hole in snap ring groove will be centered in snap ring gap. Use arbor press and Outer Race Press Plug, Part No. 97194-57 to press outer race parts into crankcase bushing one at a time as shown in Figure 3-37. Press the races into the case, one from each side, with widest ends outward to match taper of bearings. Be sure each race bottoms on the snap ring.

Position flywheel assembly in vise with sprocket shaft up. Press bearing (15) on sprocket shaft using Bearing Installing Tool, Part No. 97225-55. Sprocket shaft spacer 24036-66 may be needed with bearing installing tool as shown in Figure 3-49. Press the parts on using sprocket shaft spacer as a pressing spacer only. Turn tool screw onto sprocket shaft thread and tighten securely. Remove tool handle and slip the bearing small end up over sprocket shaft, starting it squarely. Install the small bearing spacer (10) and tool sleeve and press bearing against flange on flywheel using the tool as shown in Figure 3-49.



Figure 3-49. Pressing Bearing on Sprocket Shaft

Slip crankcase half, with outer race parts installed, over shaft. Slip bearing over tool screw, small end down toward bearing inner spacer. Position tool sleeve and turn on driver. Turn driver down against sleeve pressing bearings tightly together as shown in Figure 3-50. Bearings must be tight against the bearing spacer to provide correct bearing clearance.

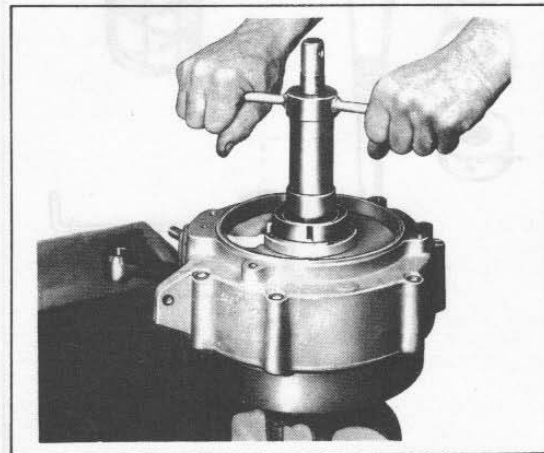

Figure 3-50. Pressing Flywheel into Crankcase

Before loosening tool, check to see that the bearing is not preloaded by shaking crankcase half and feeling for a slight amount of play of crankcase half on bearing. Note: If there is no noticeable shake, or if flywheel assembly does not rotate freely in bearing, disassemble bearing and add a .003 Shim, Part No. 23741-55, on one side of inner race spacer (10, Figure 3-37). Again install bearing with tool and re-check for slight play in bearing.

Remove assembly from vise and install bearing washer (5), bearings (4) and bearing washer (3) on pinion shaft. Install new spiral lock ring (2) on groove in pinion shaft. Slip right case half over bearing and against left case half after applying a coat of non-hardening gasket sealer to parting surfaces.

See Figure 3-35. Align case halves and tap crankcase studs (5) into holes. These two studs properly align the case halves and must be installed before remaining studs. Insert remaining studs, bolts and nuts. Tighten nuts on studs to 12 to 15 ft-lbs torque. Tighten nuts on bolts to 22 to 26 ft-lbs torque.

Check exact amount of flywheel end play with a dial indicator as directed at the beginning of this Section to determine if within specified limits. See Figure 3-51.

Install spacer (6, Figure 3-36). Press seal (7) into crankcase with lip toward outside (see Figure 3-37).

Install compensating sprocket shaft extension or solid sprocket, see Section 3, "General."

NOTE

Sprocket must be aligned with rear sprocket through use of correct thickness sprocket spacers. Method for checking and determining correct spacer thickness is given in Section 2, "Drive."

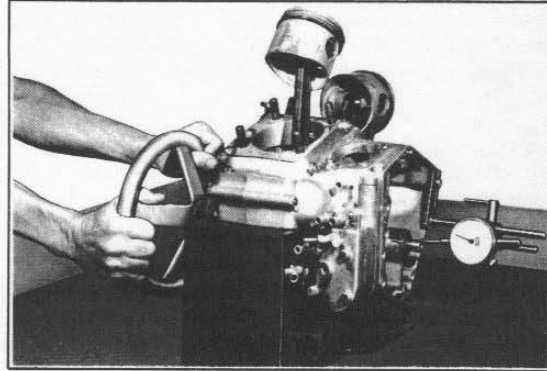

Figure 3-51. Checking Flywheel End Play

FUEL SYSTEM

TILLOTSON CARBURETOR - 1970 MODELS

DESCRIPTION (See Figure 3-52)

The Model HD carburetor is a dual-venturi, diaphragm-type carburetor with an automatic economizer and accelerating pump.

The fuel inlet needle is operated through a compression spring balanced lever that is controlled by the diaphragm to regulate the flow of fuel into the metering chamber. The amount of fuel going into the carburetor metering chamber is exactly equal to the amount of fuel being used by the engine.

This type of fuel supply control operates at any tilt angle and is resistant to any vibration which could cause a poor fuel-air mixture or flooding.

The small primary venturi is offset to the bottom of the large secondary venturi where the main nozzle outlet protrudes

from the metering chamber. The accelerating pump discharges into the small venturi to take advantage of the venturi pressure drop that breaks up the solid stream of accelerating pump fuel.

The accelerating unit is a positive acting plunger type pump that is connected to the throttle shaft through a cam lever. The pump plunger is a spring loaded leather cup that operates in a smooth plastic cylinder, and draws its fuel directly from the metering chamber to provide extra fuel for accelerating.

The automatic economizer is a hydraulically operated enrichment valve that controls the main nozzle fuel mixture at very low engine speeds. The valve opens an auxiliary fixed main jet as the venturi air flow decreases, allowing the fuel mixture to be maintained at a full power richness. As the air flow through the carburetor increases, or as the engine speed increases, the valve closes to prevent an overrich mixture at intermediate speeds.

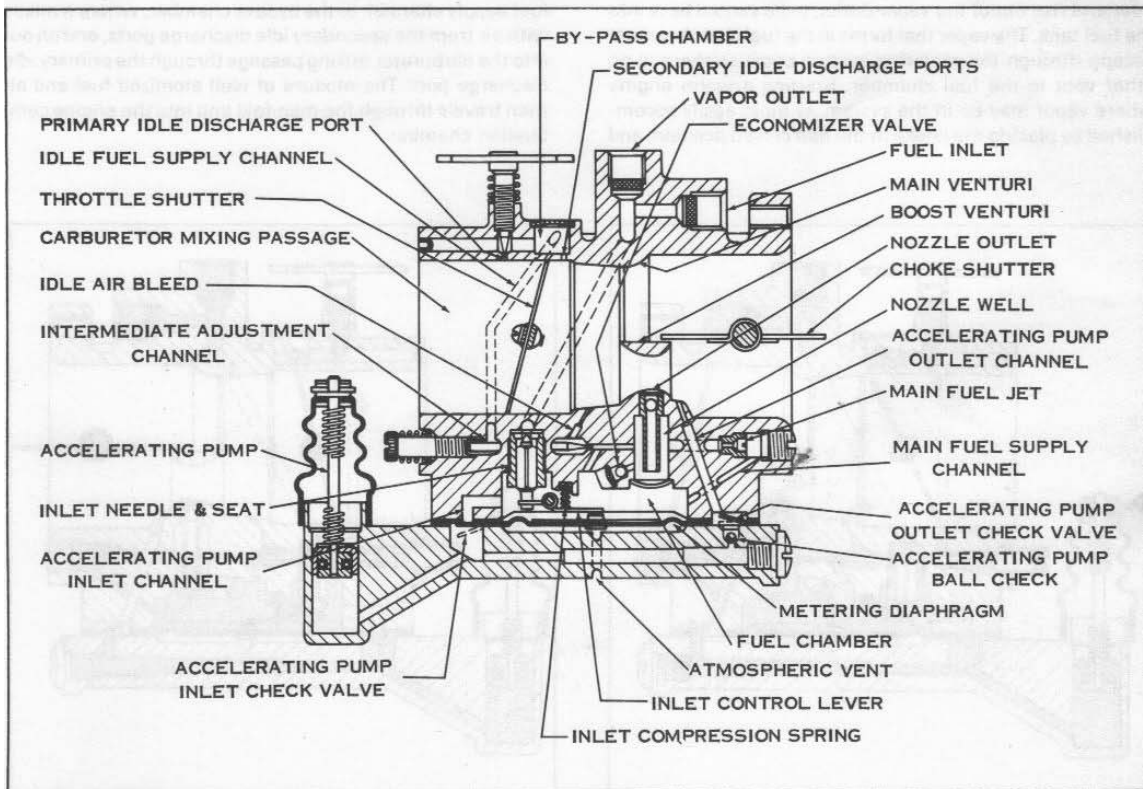

Figure 3-52. Carburetor Cross Section - Model HD

STARTING OPERATION (Figure 3-53)

Choke is in the closed position and the throttle in a slightly open position. As the engine is cranked, the entire metering system - idle, intermediate, and nozzle - is subjected to engine suction which is transmitted to the fuel chamber via the metering channels, creating a low pressure on the fuel side of the metering diaphragm. Atmospheric pressure from the atmospheric vent moves the metering diaphragm toward the inlet control lever to allow fuel to enter the carburetor through the inlet needle and seat. The fuel is then forced through the metering system, out into the carburetor mixing passage, and into the manifold and engine. When the engine fires and starts to run, the volume of air drawn through the carburetor increases, and the spring-loaded top half of the choke shutter opens to provide the additional air required by the engine, to prevent an over-rich mixture. The choke can then be moved to a half open position for engine warm-up.

During hot weather, or after an engine has been run long enough to reach stable operating temperatures, and then shut off for a short period of time, a small amount of fuel vapor may form in the fuel lines or in the fuel chamber of the carburetor. The vapor in the fuel lines will enter the fuel inlet and rise out of the vapor outlet, to be vented back into the fuel tank. The vapor that forms in the fuel chamber must escape through the metering system because there is no other vent to the fuel chamber. Starting a warm engine where vapor may be in the system, is most easily accomplished by placing the choke in the half closed position, and

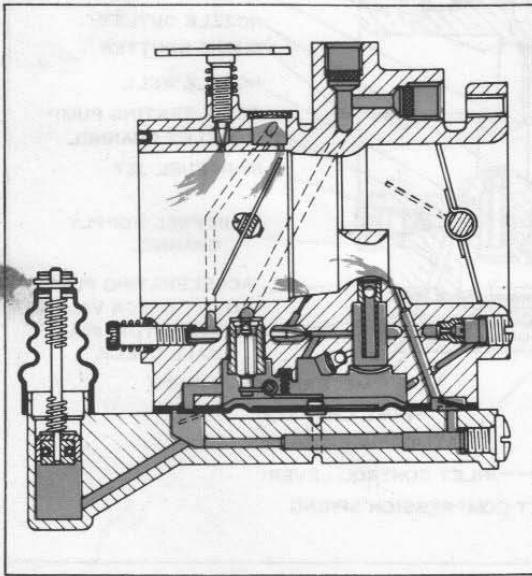

Figure 3-53. Starting

starting as described above. The choke helps to get the vapor quickly out of the fuel system so that the fuel flowing through the carburetor and fuel line can cool the system to a normal temperature.

Starting is always more easily accomplished using the choke - full choke for a cold engine, and half choke for a warm engine.

IDLE OPERATION (Figure 3-54)

The throttle shutter is slightly open when the engine is idling and the carburetor mixing passage on the engine side of the throttle shutter is exposed to engine suction, while the mixing passage between the throttle shutter and the air cleaner is at nearly atmospheric pressure. The engine suction is transmitted through the primary idle discharge port to the fuel chamber side of the metering diaphragm via the bypass chamber, idle fuel supply channel, intermediate adjustment channel, nozzle well, main fuel jet, and main fuel supply channel, creating a sub-atmospheric pressure, in the fuel chamber. The metering diaphragm is forced upward by atmospheric pressure, moving the inlet control lever to overcome the inlet compression spring pressure, allowing fuel to enter the fuel chamber through the inlet needle and seat. The fuel flows through the main fuel supply, main fuel jet, nozzle well, intermediate adjustment channel (where it mixes with air from the idle air bleed) idle fuel supply channel, to the bypass chamber, where it mixes with air from the secondary idle discharge ports, and on out into the carburetor mixing passage through the primary idle discharge port. The mixture of well atomized fuel and air then travels through the manifold and into the engine combustion chamber.

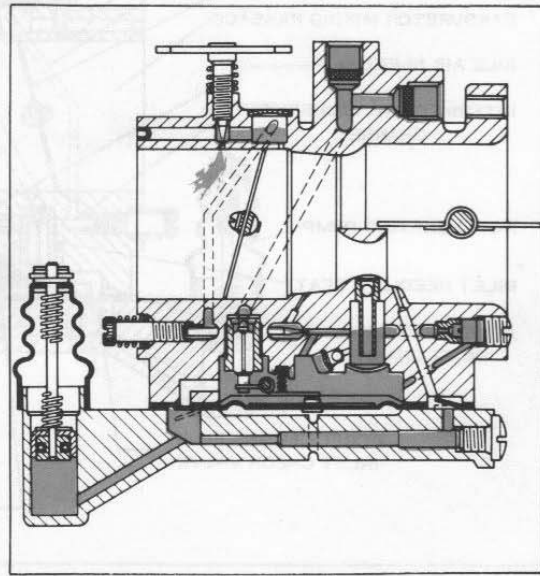

Figure 3-54. Idle

ACCELERATION (Figure 3-55)

Acceleration is accomplished by the use of a positive action accelerating pump that is actuated from the throttle shaft by a cam lever. The pump cylinder is filled when the pump is raised to the top of its stroke. Fuel is drawn from the fuel chamber, through the accelerating pump inlet channel, past the inlet check valve. The outlet check valve is closed to prevent air from being drawn into the accelerating pump system. As the accelerating pump is depressed, the pressure of the fuel closes the inlet check valve, the fuel flows through the pump channels, past the outlet check valve, through the accelerating pump outlet channel, and through the boost venturi into carburetor mixing passage.

INTERMEDIATE OR CRUISE OPERATION (Figure 3-56)

Fuel is delivered into the carburetor as described in idle operation, and the same fuel channels are in use. As the throttle shutter opens to increase engine speed, the secondary idle discharge ports are exposed to engine suction, and fuel is delivered from both the primary and secondary idle discharge ports to supply the additional fuel demanded by the engine. As the throttle shutter is opened farther, the air velocity through the boost venturi increases, creating a low pressure area at the nozzle outlet. Fuel flows from the fuel chamber through the nozzle outlet via the nozzle well, main fuel jet, main fuel supply channel, and economizer valve when the pressure at the nozzle outlet is less than the pressure in the fuel chamber. At the idle and lower intermediate speeds, the check ball in the economizer valve is away from the valve seat, allowing free flow from the fuel chamber through the economizer valve to the nozzle well and nozzle outlet. Fuel flow from the primary and secondary idle ports decreases as fuel flow from the nozzle outlet increases.

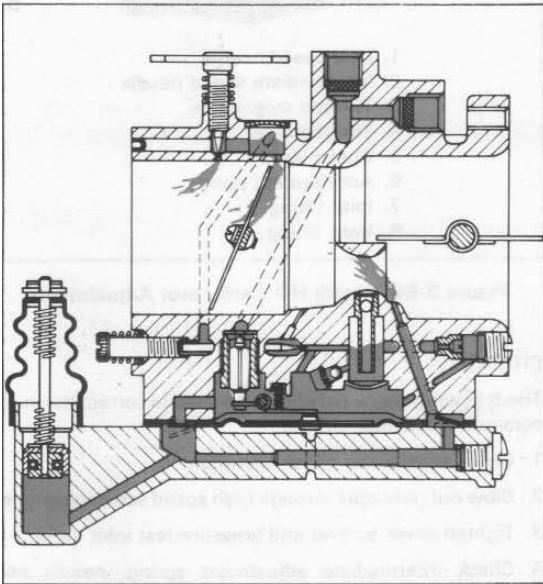

Figure 3-55. Accelerating

HIGH SPEED OPERATION (Figure 3-57)

Fuel flow from the nozzle outlet increases as the shutter is opened past the intermediate position to the fully open position. The fuel is delivered through the nozzle outlet from the fuel chamber via the main fuel supply channel and the main fuel jet. The increased pressure difference between the small venturi and the metering chamber, plus the force of fuel flowing through the economizer valve, causes the check ball to seat, stopping the flow of fuel from this part of the main metering system. This gives increased economy at high speeds. The diaphragm action and the method of fuel delivery to the fuel chamber is the same as previously described.

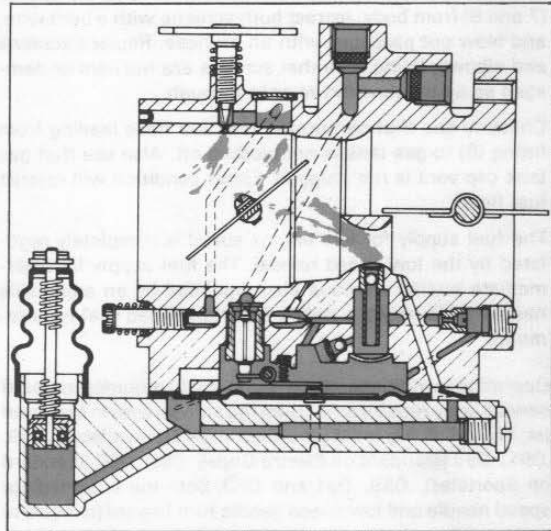

Figure 3-56. Intermediate Speed

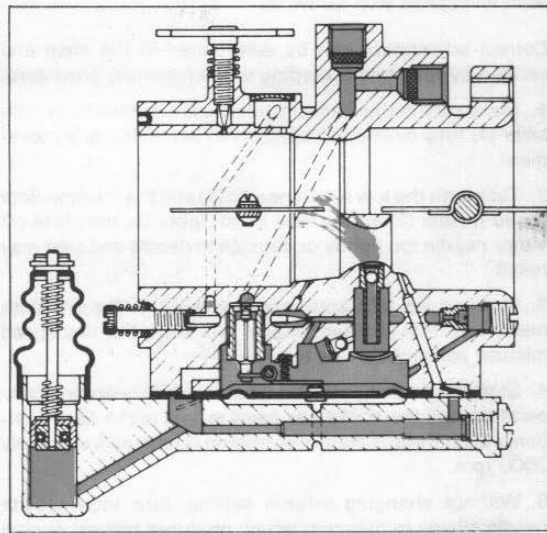

Figure 3-57. High Speed

ADJUSTING CARBURETOR (Figure 3-58)

The carburetor, once properly adjusted, requires little if any readjustment. It should not be necessary to adjust the low speed needle (1) more than 1/8 turn and the intermediate speed needle (2) more than 1/4 turn, richer or leaner, to correct the mixture for a change in weather conditions.

Before attempting to correct faulty engine performance through carburetor adjustment, check over "Locating Operating Troubles," Section 1C. In addition be sure air cleaner element is not blocked with dirt and check manifold connections to be sure they are tight and not leaking air.

Inlet fitting (7) and vent fitting (8) have strainer screens located in threaded holes in carburetor body. If faulty carburetion indicates fuel flow is restricted, remove elbow fittings (7 and 8) from body, extract both screens with a bent wire, and blow out passages with an air hose. Replace screens and elbows, being sure that screens are not bent or damaged so as to allow dirt to pass through.

Check to see that carburetor vent line hose leading from fitting (8) to gas tank is not blocked off. Also see that gas tank cap vent is not plugged. Either condition will restrict fuel flow.

The fuel supply for low engine speed is completely regulated by the low speed needle. The fuel supply for intermediate engine speed is also regulated by an adjustable needle. A fixed jet supplies the high speed fuel requirements.

Operating conditions, such as at high altitudes or hard service, may require other than the standard main fuel fixed jet. The following main jet orifice sizes are available: .049, .051, .053 (standard on Electra Glide), .055, .057 (standard on Sportster), .059, .061 and .063. Both the intermediate speed needle and low speed needle turn inward (to right) to make mixture leaner at the respective speeds for which they adjust. Blocking them out (to left) makes mixture richer. Closed throttle idling speed of engine is adjusted with idle speed stop screw (3).

Correct adjustment can be determined in the shop and verified by road test according to the following procedure.

1. Make sure carburetor control wire is adjusted so throttle lever (4) fully closes and opens with handlebar grip movement.
2. Turn both the low speed needle (1) and the intermediate speed needle (2) all the way in (to right). Do not close off either needle too tightly or damage to needle and seat may result.
3. Back up (to left) both needles about 7/8 turn. With needles in this position, engine will start, but low speed mixture will probably be too rich.
4. Start the engine and after it has reached operating temperature and the choke has been moved to the open position, adjust throttle control so engine runs at approximately 2000 rpm.
5. Without changing throttle setting, turn intermediate needle slowly in direction which produces highest engine speed (rpm). Engine should not miss or surge at this adjustment position.

3-42

6. Back of intermediate needle 1/8 turn to slightly richer mixture. This is the correct intermediate needle adjustment.

7. Readjust idle needle and idle speed stop screw to produce a smooth idle at desired idle speed (900 to 1100 rpm or 700 or 900 with heavy springs).

NOTE

Use of an electric tachometer is recommended.

8. Changing either mixture setting also affects the other setting to some degree. Therefore, it will be necessary to recheck the low speed mixture after the intermediate mixture final setting is obtained.

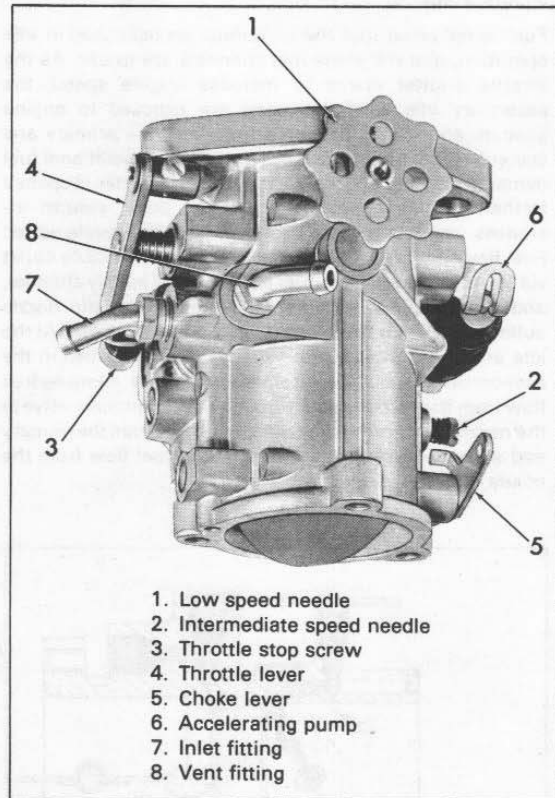

Figure 3-58. Model HD Carburetor Adjustments

CHECK LIST

The following check list should be used to correct the most common carburetor defects.

1. Check accelerator pump operation.
2. Blow out passages through high speed screw plug hole.
3. Tighten cover screws and pressure test inlet valve.
4. Check intermediate adjustment spring, needle and needle seating.
5. Test main nozzle ball check valve with tool.

6. Inspect idle needle and seat.
7. Inspect choke relief disc.
8. Inspect and clean discharge ports, diaphragms and gaskets, screens and passages. Diaphragm plate must not turn.
9. Check inlet lever setting – must be flush to 1/64 in. above floor of casting. Lever and needle must be the shackled type.
10. Test economizer ball check valve with tool.
11. Check assembly order – gasket next to body, then diaphragm, last cover.

NOTE

A more detailed guide is given at the end of this Section.

INSPECTING AND TESTING

(Checks and tests for carburetor performance)

NOTE

All inspections and tests should be performed, in the sequence shown below, before further disassembly or repairs are made.

PRIOR TO REMOVAL OF CARBURETOR FROM ENGINE
(Figure 3-59)

1. The accelerator pump should be inspected for proper operation first. Remove air cleaner, prime carburetor by inserting a toothpick through small hole in bottom of plastic pump cover and gently working diaphragm several times. Operate the throttle lever both rapidly and slowly several times, with the fuel valve turned on. The pump should deliver a strong and constant jet of fuel with each stroke. Failure to do so indicates diaphragm valves or pump plunger as being defective.
2. In cleaning of high, intermediate and low speed channels, the following procedure, most likely, will dislodge any loose dirt lodged in the passages.

Remove high speed screw plug located on rear side of carburetor, opposite intermediate adjustment needle. Lightly seat intermediate needle and apply air hose pressure (90 pounds maximum) to screw plug hole. Open intermediate and idle needles three or four turns and again apply 90 pounds maximum air pressure. Reset both adjustment screws (see Adjusting Carburetor). Evaluate carburetor's performance by road testing.

3. Check inlet needle and seat for leakage, as follows:

See that all plastic cover screws are tight. Remove fuel and vent lines, install bulb tester, Part No. 94750-68, to carburetor fuel inlet fitting, plug vent fitting with finger and pressurize tester noting any leakage. A moistened needle and seat should hold 1 to 1-1/2 lbs approximately, and release at approximately 3 to 5 lbs. A dry needle and seat will not hold as well as a moist one. See Figure 3-59.

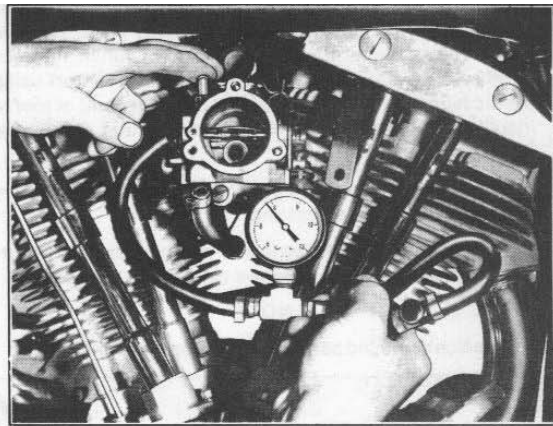

Figure 3-59. Checking Inlet Needle and Seat for Leakage

REMOVE CARBURETOR BUT DO NOT DISASSEMBLE (Figure 3-60)

4. Inspect intermediate adjustment needle and spring to see if spring coils are binding before needle seats. If needle does not seat grind a small amount of material from each end of spring. You can check to see if needle is seating by applying blue dye to needle taper and screwing down lightly into seat and noting mark on needle taper.

5. Check main nozzle ball check valve for leakage, as follows:

Seal one side of venturi with finger and apply alternate pressure and vacuum by mouth using grommet end of tool, Part No. 96960-68, sealed in venturi as shown in Figure 3-60.

Vacuum should release ball, and pressure should seat ball in nozzle assembly.

If leakage is evident, carburetor must be disassembled and main nozzle check valve assembly replaced.

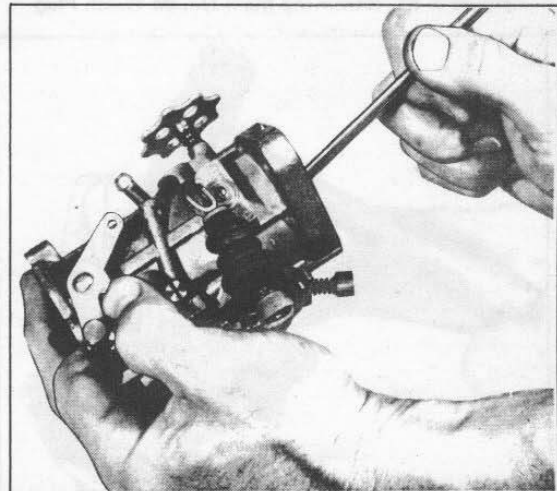

Figure 3-60. Checking Main Nozzle Ball Check Valve for Leakage

To replace main nozzle, puncture welch plug with pointed tool, avoiding center, as shown in Figure 3-61. Remove nozzle welch plug and use stepped end of punch, Part No. 96962-68, on nozzle, tapping it through into venturi using plastic hammer. See Figure 3-62. Use larger end of tool to install the new check valve in the same manner. See Figure 3-63.

6. Inspect idle needle and seat in carburetor bore for any distortion or a cracked casting.

7. Inspect choke relief disc (upper half of choke) for distortion or stress cracks at the area rotating on choke shaft.

NOTE

Replace damaged parts only after completing all tests.

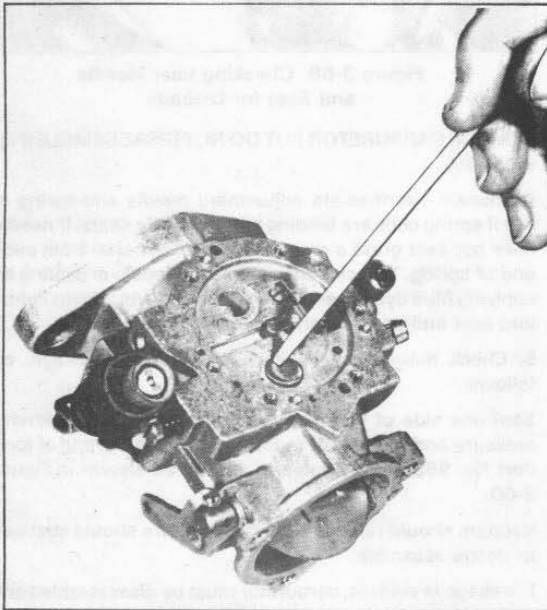

Figure 3-61. Removing Main Nozzle Welch Plug

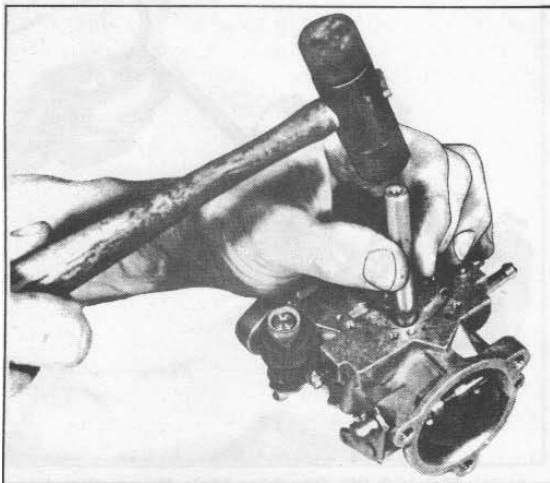

Figure 3-62. Removing Main Nozzle

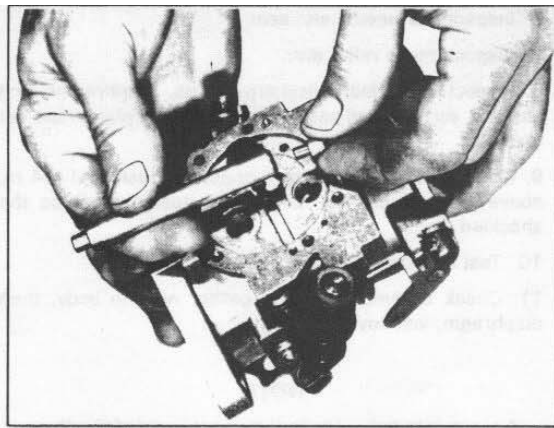

Figure 3-63. Installing Main Nozzle

8. Remove plastic diaphragm cover. Inspect accelerator pump leather for fold over or coil spring out of correct position.

Check accelerator pump outlet ball check valve to see that ball is free.

Inspect gasket and diaphragm for distortion or misplacement on carburetor body. Diaphragm must not be stretched or have a rippled appearance particularly within the valley portion which should be uniform in shape. (Gasket should be assembled next to body.)

Lightly make attempt to rotate metal diaphragm washer, riveted to upper side of diaphragm. If diaphragm plate rotates freely with no drag, replace diaphragm assembly. Diaphragm plate should not be loose.

Prior to removal of the inlet lever the initial needle seat leakage test should be performed 10 to 12 times with the bulb tester, as follows: Close bulb valve. Apply pressure to the inlet, sealing the vent fitting. Open bulb valve and again apply pressure. This repetition checks the sealing of the needle in the seat ensuring that it is not sticking open at lever pin or at groove in needle.

9. Inspect inlet needle lever for correct adjustment. It should be flush with surrounding floor of carburetor body. If not equipped with shackled needle, replace with Kit No. 27588-66. Tighten seat to 45 in-lbs torque. See Figure 3-64.

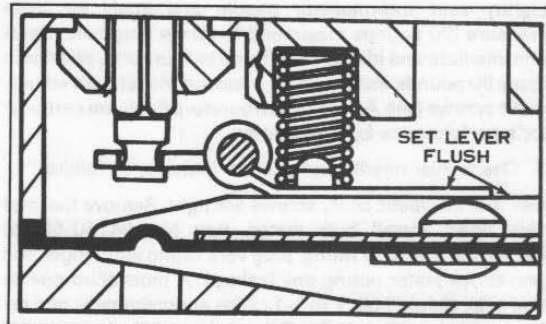

Figure 3-64

10. Test economizer ball check for leakage and correct operations as follows:

Using hose end of tool, Part No. 96960-68 place it over economizer welch plug hole so it seals off surrounding area. With alternate pressure and vacuum applied with mouth, as shown in Figure 3-65, ball check should release and seal. Replace any defective parts.

After plastic cover has been removed, remove welch plug at idle adjuster, all gaskets, diaphragms, needle and seat, and high speed nozzle before cleaning carburetor in a caustic carburetor cleaner, since the caustic cleaner will damage gasket material and the high speed nozzle plastic check ball. Only gaskets which are in perfect condition should be re-used. The metal parts may also be cleaned in lacquer thinner with a small brush and blown dry.

Inspect by attempting to rotate, or move all welch plugs in body. A close inspection of wall area around welch plugs can disclose a leaking condition. Whenever a welch plug is removed, a new one should be reinstalled. If leakage is suspected due to rough or damaged welch plug seat in casting, apply a small amount of seal-all to edge of welch plug after installing it in recess.

After carburetor has been reassembled, recheck accelerator pump per item 1 under "Tests."

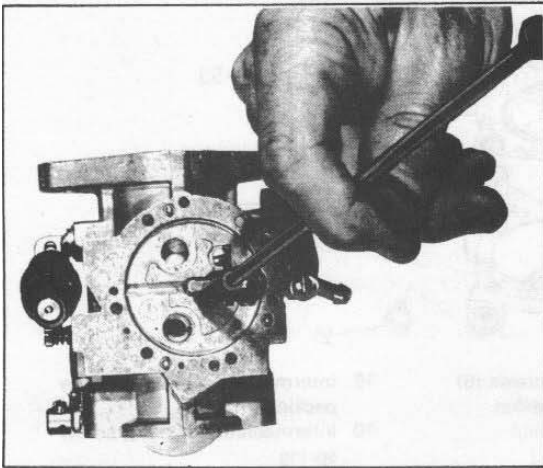

Figure 3-65. Checking Economizer Ball Check Valve for Leakage

DISASSEMBLING CARBURETOR (Figure 3-66)

Remove idle (26) and intermediate (38) fuel adjustments.

Remove two throttle shutter screws (52) and the throttle shutter (51). The sides of the shutter are tapered 15° to conform to the throttle bore. Observe the direction of this taper and the position of the shutter so that it can be reassembled later in the correct position.

Remove the accelerating pump lever retaining screw (3) and pull the throttle shaft assembly (46) out of the carburetor body. Remove compression spring (50), washers (49), and shaft dust seals (48).

Remove six screws and washers (22) and the body cover (18).

Remove accelerating pump plunger assembly (1).

Remove channel plug screw (21).

Remove metering diaphragm (17).

Remove metering diaphragm gasket (23). Note that the gasket is assembled next to the body casting.

Remove fulcrum pin retaining screw (34), fulcrum pin (33), inlet control lever (32), and metering spring (37).

Remove the inlet needle (32).

Remove the inlet seat and cage assembly (35), using a 3/8 in. thin wall hex socket wrench. Note the position of the inlet seat insert with the contoured side toward the outside of the cage and the smooth side toward the inside of the cage.

Remove the inlet seat gasket (36), using a small tap or bent wire.

Remove plug screw (44).

Remove fixed main jet (42) and gasket (43).

Remove main nozzle welch plug (6) by drilling 1/8 in. diameter hole off center and just breaking through the welch plug. Do not drill deeper than the welch plug because this would probably damage the nozzle assembly. Pry out the welch plug with a small punch, being careful not to damage the casting counterbore edges around the plug.

Remove idle port welch plug (6), using the same procedure described above.

Remove welch plug (8) and economizer check ball (24). Pry out the welch plug carefully, using a small punch.

Remove two choke shutter screws (16) and the bottom half of the choke shutter (15).

Pull the choke shaft assembly (13) out of the body. This will release the top half of the choke shutter (11), the spring (12), the choke friction ball (9), and friction ball spring (10).

Remove the choke shaft dust seal (14).

CLEANING, INSPECTION AND REPAIR (Figure 3-66)

The carburetor body can be cleaned in commercial carburetor solvent such as Hydroseal to remove varnish from the channels and metering chamber.

NOTE

All gaskets, rubber gaskets, seals and plastic parts, including items 18, 24 and 45, should be removed and only metal parts cleaned in Gunk Hydroseal cleaning solution.

All channels and orifices in the carburetor and pump body castings should be cleaned with compressed air. **DO NOT** use wires or drills to clean small holes. These might cause burrs or change the size of the holes.

Inspect all parts for wear or damage paying particular attention to the following:

Examine pump body casting for breaks and cracks.

The inlet control lever must rotate freely on the fulcrum pin and forked end must engage slot in inlet needle (see Figure 3-64). The spring (37) should not be stretched or distorted.

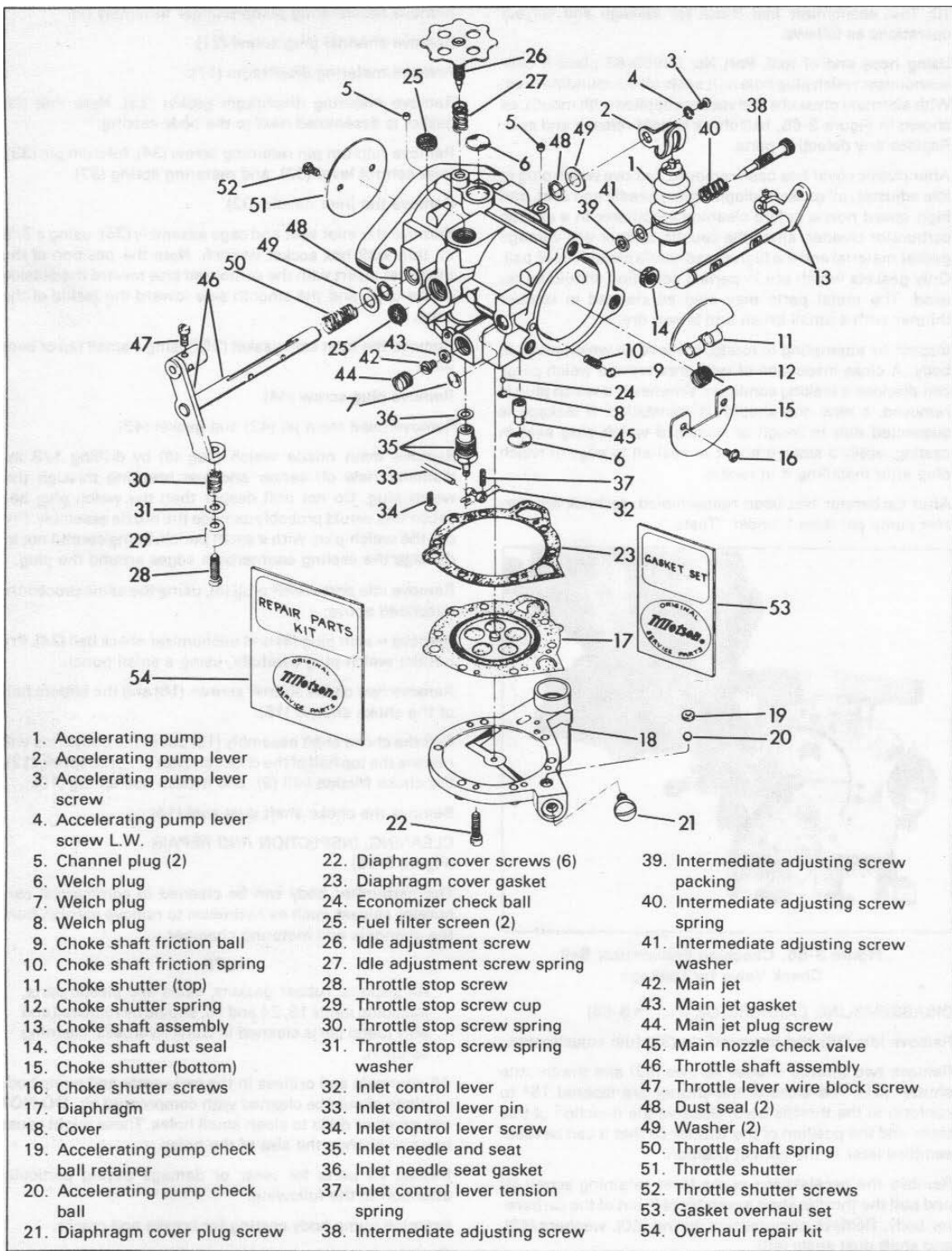

Figure 3-66. Model HD Carburetor - Exploded View

Inspect the inlet needle (35) cone point for wear and scratches. Inspect the lever (32) contact end for burrs and wear.

ASSEMBLING CARBURETOR (Figure 3-66).

Make certain that all parts are kept clean during reassembly. Do not use cloths to wipe or dry parts. Lint or threads can easily block small orifices. Welch plugs should be seated with a flat end punch of a slightly smaller diameter than the welch plug. The seated plug should be flat, not concave, to assure a tight fit around the circumference.

The metering spring (37) should be seated into the counterbore in the body casting, and located on the protrusion on the inlet control lever (32). The lever should be adjusted flush with the floor of the metering chamber by bending diaphragm end of lever as necessary.

Two torque values are important: (1) the inlet seat assembly (35) should be tightened to 40-45 in-lbs; and (2) the accelerating pump channel plug (21) should be tightened to 23-28 in-lbs.

TROUBLESHOOTING GUIDE (Figure 3-66)

The following symptoms and possible causes with corrective service can be used as a guide in servicing the carburetor.

A. Idle System

1. Idle operation too lean.

- a. Dirt in idle fuel channels – blow out with compressed air.
- b. Intermediate adjustment (38) closed or adjusted too lean – readjust.
- c. Welch plug (6) or channel plugs (5) missing or not tightly sealed – reseal or replace plugs.
- d. Nozzle check valve (45) not sealing – blow out with compressed air, or replace. (See "Check List" No. 5.)

2. Idle operation too rich.

- a. Carburetor flooding – see Item E.
- b. Idle adjustment screw (26) point damaged – replace the adjustment screw.
- c. Idle adjustment hole damaged, forced oversize, or casting cracked in the idle port area – replace carburetor.

B. Intermediate System

1. Lean operation at steady speeds between 15 and 65 mph.

- a. Intermediate adjustment (38) adjusted too lean – readjust.
- b. Dirt in intermediate fuel ports or supply channels – remove welch plug (6) and channel plugs (5) and blow out with compressed air.
- c. Welch plug (6) or channel plugs (5) not tightly sealed – reseal or replace plugs.
- d. Nozzle check valve (45) not sealing – blow out with compressed air, or replace. (See "Check List" No. 5.)
- e. Intermediate adjustment packing (39) missing or damaged – replace.

- f. Economizer check ball (24) stuck closed – remove welch plug (8) and check ball (24) and blow out channel with compressed air. (See "Check List" No. 10.)

2. Rich operation at steady speeds between 15 and 65 mph.

- a. Intermediate adjustment (38) adjusted too rich – readjust.
- b. Fixed main jet (42) too large, not tightly in place or missing – seat firmly, or replace jet.
- c. Carburetor flooding – see Item E.
- d. Nozzle check valve welch plug (6) not tightly sealed – reseal or replace.
- e. Choke valve partially closed – see that choke friction spring (10) and choke friction ball (9) are correctly assembled.

C. Nozzle System

1. Lean operation at speeds above 60 mph.

- a. Dirt in nozzle system – remove main fuel jet plug screw (44) and blow channels out with compressed air.
- b. Main fuel jet (42) too small or damaged – replace.
- c. Main fuel jet plug screw (44) not tightly sealed – tighten to stop air leak.
- d. Nozzle check valve (45) damaged – replace. (See "Check List" No. 5.)
- e. Nozzle check valve (45) not seated correctly in casting – reseal flush with nozzle well surface.

2. Rich operation at speeds above 60 mph.

- a. Main jet (42) too large, not tightly in place or missing – seat firmly or replace.
- b. Carburetor flooding – see Item E below.
- c. Economizer check ball (24) not seating – remove welch plug (8) and check ball (24) and blow channel out with compressed air. (See "Check List" No. 10.)

D. Accelerating Pump System

1. Lean acceleration.

- a. Incorrect carburetion adjustment – readjust idle (26) and intermediate adjustments (38).
- b. Dirt in acceleration fuel channels – blow out all channels in diaphragm cover (18) and the accelerating pump discharge channel in the body casting. (See "Check List" No. 1.)
- c. Accelerator pump assembly (1) damaged or worn – replace assembly. (See "Check List" No. 1.)
- d. Diaphragm cover plug screw (21) loose or missing – tighten or replace.
- e. Diaphragm (17) flap check valves damaged or worn – replace diaphragm.
- f. Economizer check ball (24) stuck closed – remove welch plug (8) and check ball (24) and blow channel clean with compressed air. (See "Check List" No. 10.)

E. Carburetor Flooding

1. Dirt in inlet needle and seat assembly (35) – remove and clean, or replace. (See "Check List" No. 3.)
2. Inlet seat gasket (36) missing or damaged – replace.
3. Inlet control lever (32) not correctly adjusted – readjust lever flush with metering chamber wall. (See "Check List" No. 9.)
4. Diaphragm (17) incorrectly installed – replace or correct installation.
5. Inlet control lever pin (33) loose or not correctly installed – tighten retaining screw (34) and correct installation.
6. Inlet control lever (32) tight on lever pin (33) – replace damaged part, or clean dirt from these parts.
7. Inlet needle or seat (35) damaged or worn – replace the assembly.

F. General Operation

1. Lean operation in all speed ranges.
 - a. Filter screens (25) plugged or dirty – clean or replace.
 - b. Inlet control lever (32) incorrectly adjusted – readjust lever flush with wall of metering chamber. (See "Check List" No. 9.)
 - c. Diaphragm cover plate (18) loose – tighten six screws (22).
 - d. Air leak in metering system – all channel plugs, plug screws, and lead plugs to be tightly sealed.
 - e. Inlet tension spring (37) stretched or damaged – replace.
2. Rich operation in all speed ranges.
 - a. Carburetor flooding – see Item E.
 - b. Choke valve not staying fully open – see that choke friction spring (10) and friction ball (9) are assembled correctly.
 - c. Inlet control lever (32) incorrectly adjusted – readjust lever flush with wall of metering chamber. (See "Check List" No. 9.)

BENDIX CARBURETOR - 1971 TO 1975 MODELS

DESCRIPTION

The Model 16P12 carburetor is a horizontal plain tube type with a fuel bowl, a single ring-shaped float, an accelerating pump, idle mixture adjusting needle and a throttle stop screw for idle speed adjustment.

The throttle body casting contains an integral venturi and a fuel valve seat that is pressed into the body. The underside of the throttle body contains a long boss. The main jet and discharge tube assembly screws into the boss with the end of the tube projecting up into the venturi.

3-48

OPERATION

Fuel Supply System, Figure 3-65

Fuel under pressure enters the float chamber through the fuel inlet and fuel valve (needle and seat). The fuel level in the bowl is automatically maintained by the float which opens and closes the needle valve to supply the varying fuel flow demands of the engine as shown in Figure 3-65. A clip attached to the end of the needle valve engages a tab of the float assembly.

Accelerating system, Figure 3-67

The accelerating pump controls the amount of additional fuel that is discharged into the air stream upon sudden throttle opening.

The accelerating system consists of a pump assembly, accelerating jet, a check valve and the mechanical linkage that connects to the throttle shaft.

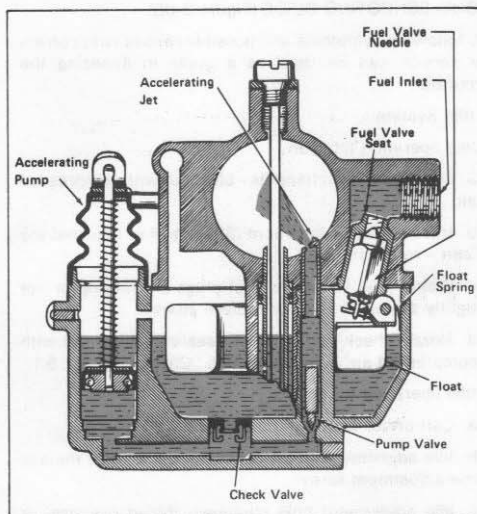

Figure 3-67. Fuel Supply and Accelerating Systems

Idle System, Figure 3-68

The fuel for idle is drawn from the main metering well through the idle tube and is mixed in the channel leading to the idle discharge holes with air entering through the idle air bleed. At slow idle speed, the throttle plate is positioned as shown in Figure 3-68 to expose only the No. 1 idle discharge hole to engine vacuum. Air is admitted to the idle channel through the No. 2, 3 and 4 (late 1972) idle holes. This air mixes with the fuel-air mixture in the channel and is discharged through the No. 1 idle hole.

As the throttle plate is opened, the idle holes progressively discharge fuel-air mixture to supply the increased fuel required at the higher engine speeds.

The idle adjusting needle regulates the fuel-air mixture flowing through the No. 1 idle discharge hole. Turning the needle IN (clockwise) results in a leaner mixture. Turning it OUT (counterclockwise) provides a richer mixture. The idle speed is set by adjusting the throttle stop screw – not the idle adjusting needle.

Choke System, Figure 3-68

Before cranking the engine, the throttle should be opened to expose all three idle holes. The choke plate should be held fully closed during the cranking. After the engine starts, open the choke slightly. A hole in the choke plate helps to prevent over-choking when the engine is started. The choke should be moved to wide open when the engine is partially warmed up.

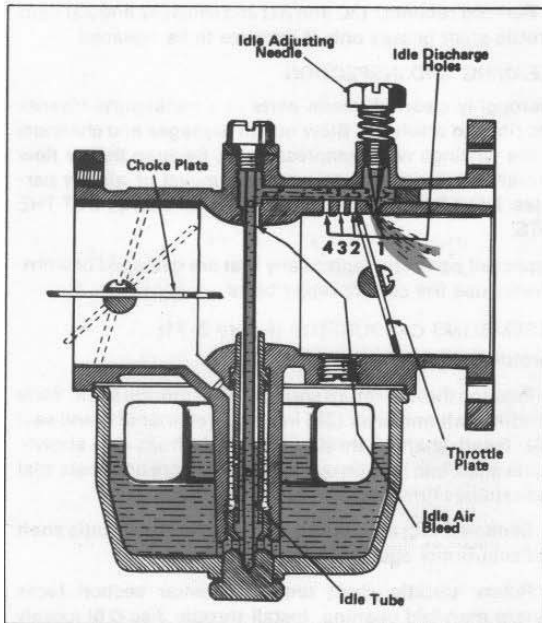

Figure 3-68. Idle and Choke Systems

High Speed (Main Metering) System, Figure 3-69.

The fuel for engine operation from off idle to full throttle range is supplied from the fuel bowl through the main metering jet, metering well and discharge tube. As the fuel flows through the metering well and tube, it mixes with air entering through the well vent to provide the correct fuel air mixture ratio for all engine speeds and loads. A series of air bleed holes in the discharge tube permits the air from the well vent to enter the bowl below the level of the fuel in the float chamber. This reduces the average density of the fuel and enables it to flow freely at low suction. At high engine speeds (and high suction), the proportion of air to fuel through the main metering system is reduced to provide the richer mixture needed for peak performance.

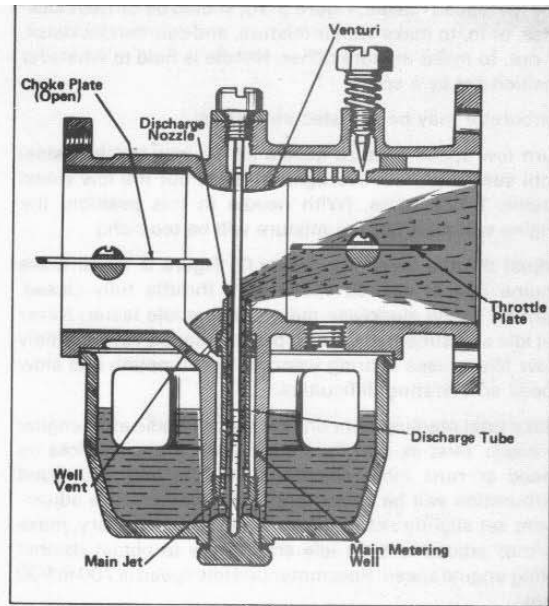
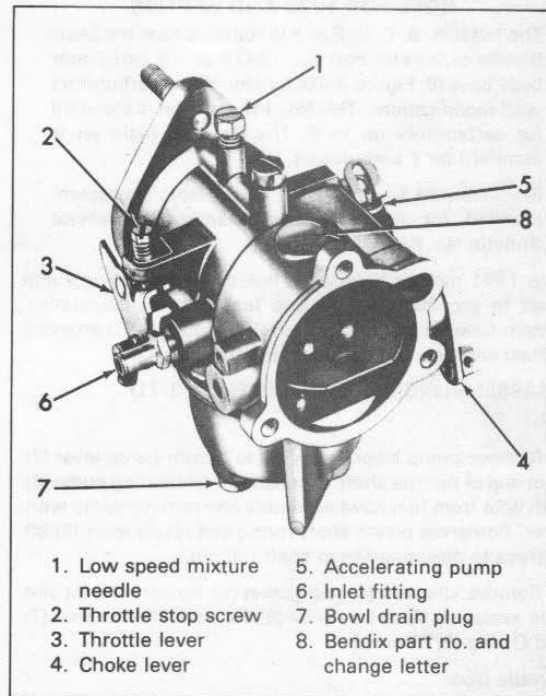

Figure 3-69. High Speed System

ADJUSTING CARBURETOR (Figure 3-70)

Before attempting to correct faulty engine performance through carburetor adjustment, check over "Locating Troubles," Section 1. In addition, be sure air cleaner element is clean, and check carburetor and manifold connections to be sure they are tight and not leaking air.



- | | |
|-----------------------------|--------------------------------------|
| 1. Low speed mixture needle | 5. Accelerating pump |
| 2. Throttle stop screw | 6. Inlet fitting |
| 3. Throttle lever | 7. Bowl drain plug |
| 4. Choke lever | 8. Bendix part no. and change letter |

Figure 3-70. Bendix Carburetor Adjustments

The low speed needle, Figure 3-70, should be turned clockwise, or in, to make leaner mixture, and counterclockwise, or out, to make mixture richer. Needle is held to whatever position set by a spring.

Carburetor may be adjusted as follows:

Turn low speed mixture needle all the way in (clockwise) until seated (do not overtighten). Back out the low speed needle 1-1/2 turns. (With needle in this position, the engine will start but the mixture will be too rich.)

Adjust throttle lever stop screw (2, Figure 3-70) to make engine idle at desired speed with throttle fully closed. Turning screw clockwise makes engine idle faster. Never set idle adjustment to slowest possible speed. An extremely slow idle causes bearing wear, oil consumption and slow speed accelerating difficulties.

Make final readjustment on low speed needle after engine is warm. First in, and then out, to see if engine picks up speed or runs more smoothly. Starting and all around carburetion will be better with low speed mixture adjustment set slightly rich rather than lean. If necessary, make further adjustment on idle stop screw to obtain desired idling engine speed. Recommended idle speed is 700 to 900 rpm.

During high speed operation, fuel is metered by a fixed jet which has no adjustment.

Operating conditions, such as high altitudes or hard service, may require other than the standard main fuel fixed jet. The following main fuel jet orifice sizes are available: No. 90, No. 95, No. 100, No. 105, No. 110, No. 115, No. 120 and No. 125.

NOTE FOR 1973 AND EARLIER

The letter A, B, C, D, E or F is stamped near the basic Bendix carburetor Part No. 13479 on the carburetor body boss (8, Figure 3-70) for identifying carburetors with modifications. The No. 115 main jet is standard for carburetors up to E. The No. 110 main jet is standard for F carburetors.

Modifications to early 1971 carburetors are recommended for improved performance per Service Bulletin No. 614A.

Late 1971 models have extra holes in accelerating pump shaft to provide more or less fuel upon acceleration - bottom hole for pump shaft pin (37, Figure 3-71) provides richest setting - top hole, leanest setting.

DISASSEMBLING CARBURETOR (Figure 3-71)

Bowl

1. Remove pump lever screw (1) to loosen pump lever (2) from end of throttle shaft. Disengage accelerating pump (3) with boot from fuel bowl assembly and remove pump with lever. Compress piston shaft spring and rotate lever (2) 90 degrees to disengage from shaft roll pin.

2. Remove idle tube (4) and gasket (5). Remove the jet and tube assembly (6) to free bowl (9). Remove fiber washer (7) and O-ring (8) from tube.

Throttle Body

1. Use scribe or heavy wire to press float pin (11) out of float hinges.

2. Remove float assembly (12), float spring (13) and float valve assembly (14) from throttle body.

3. Remove bowl to body gasket (15).

4. Remove idle mixture needle (16) and spring (17). Then remove throttle stop screw (18) and spring (19).

5. Close choke disc (20) and remove screws (21). Remove disc from air intake opening and slide choke shaft and lever (22) out of shaft hole, plunger and spring (22A and 22B) will be released.

6. Remove seal retainer (23) and seal (24) from inside choke shaft opening only if they are to be replaced. Do not remove cup plug (25) from other choke shaft opening unless the plug is damaged and is to be replaced.

7. Close throttle disc (26) and remove two small screws (27). Then remove throttle disc and shaft and lever (28). Remove spring (29) from throttle shaft.

8. Remove retainers (30 and 31) and seals (32 and 33) from throttle shaft bosses only if they are to be replaced.

CLEANING AND INSPECTION

Thoroughly clean all metal parts in a metal parts cleaner and rinse in a solvent. Blow out all passages and channels in the castings with compressed air. Reverse the air flow through each passage to ensure removal of all dirt particles. NEVER USE A WIRE OR DRILL TO CLEAN OUT THE JETS.

Inspect all parts and replace any that are damaged or worn. Always use the correct repair parts.

ASSEMBLING CARBURETOR (Figure 3-71)

Throttle Body

1. Position throttle return spring (29) on throttle shaft. Slide throttle shaft and lever (28) into seal retainer (31) and seal (33). Insert shaft in throttle shaft hole from side shown. Guide shaft into hole on opposite side of bore and press seal and retainer firmly against shaft hole boss.

2. Slide seal (32) and retainer (30) over end of throttle shaft and seat firmly against shaft hole boss.

3. Rotate throttle shaft until flat center section faces toward manifold opening. Install throttle disc (26) loosely with screws (27). Snap disc open and shut several times to center disc, and then tighten screws holding the throttle disc seated in the casting. Be sure the disc is held tightly closed.

4. Insert seal (24) and retainer washer (23) in choke shaft hole. Use a small punch to stake retainer in place.

5. Slide choke shaft and lever (22) through retainer and seal and seat shaft in hole on opposite side of air intake. Install plunger and spring (22A and 22B) at this time.

6. Rotate choke shaft until flat center section faces toward intake opening. Install choke disc (20) loosely with screws (21). Snap disc open and shut, and then tighten screws using the same procedure as for throttle.

7. If choke cup plug (25) was removed, install new plug in choke shaft hole on opposite side of throttle body.

8. Place throttle body with fuel bowl side up and install bowl to body gasket (15).

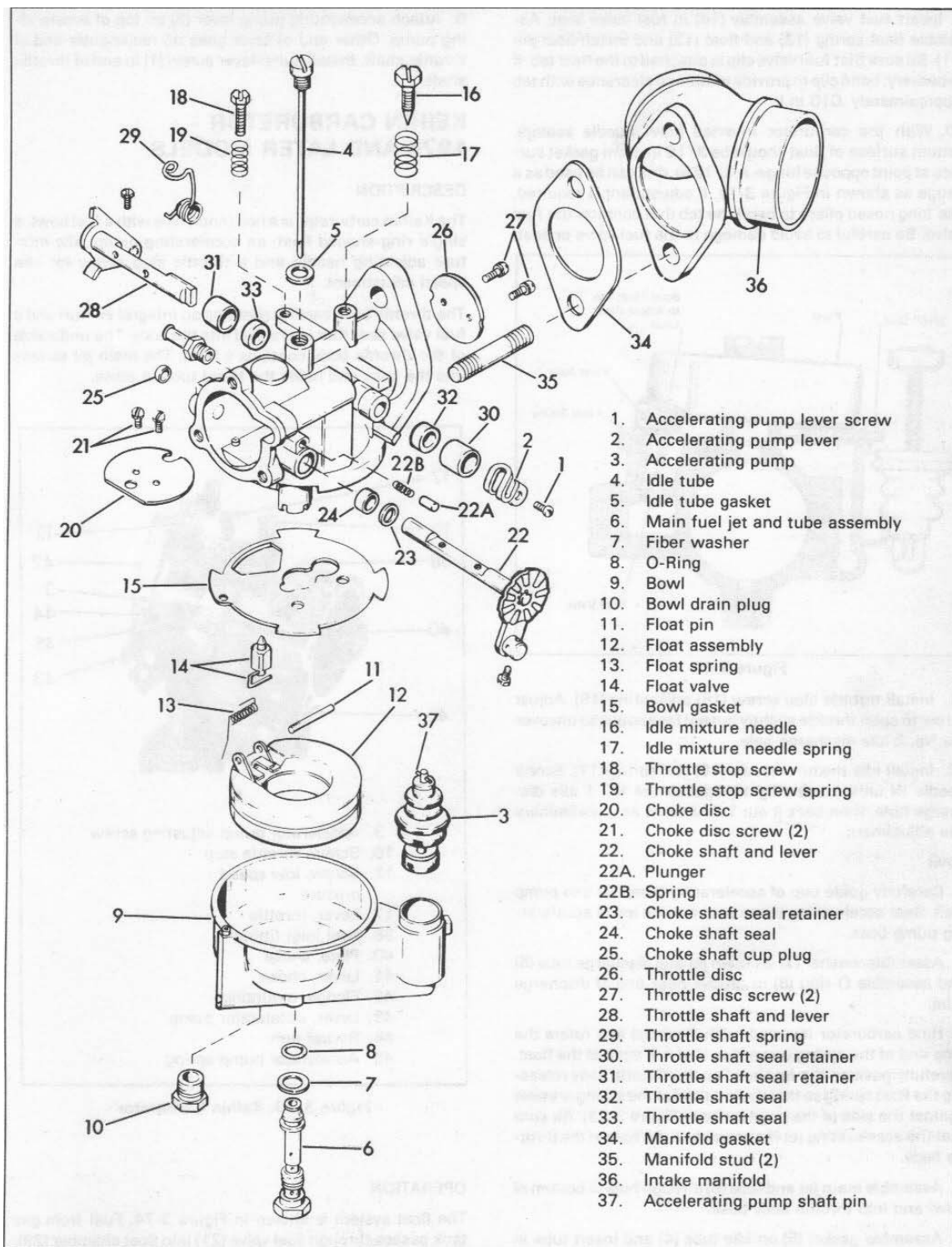

Figure 3-71. Bendix Carburetor - Exploded View

9. Insert fuel valve assembly (14) in fuel valve seat. Assemble float spring (13) and float (12) and install float pin (11). Be sure that fuel valve clip is attached to the float tab. If necessary, bend clip to provide minimum clearance with tab (approximately .010 in.).

10. With the carburetor inverted (inlet needle seated), bottom surface of float should be 3/16 in. from gasket surface at point opposite hinge. A 3/16 in. drill can be used as a gauge as shown in Figure 3-72. If adjustment is required, use long nosed pliers to bend the tab that contacts the fuel valve. Be careful to avoid damage to the fuel valve or seat.

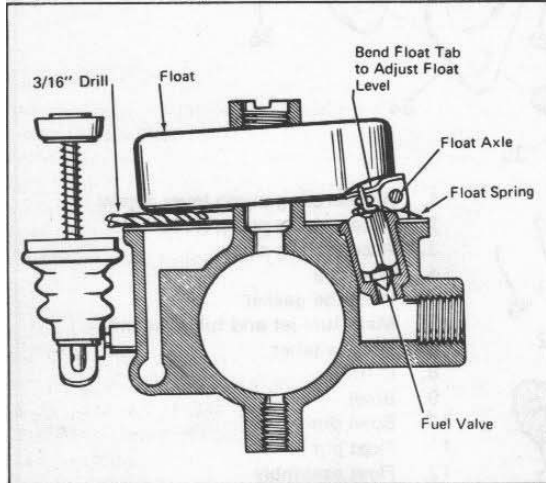

Figure 3-72

11. Install throttle stop screw (18) and spring (19). Adjust screw to open throttle slightly but not far enough to uncover the No. 2 idle discharge hole.

12. Install idle mixture needle (16) and spring (17). Screw needle IN until it seats lightly against the No. 1 idle discharge hole, then back it out 1-1/2 turns as a preliminary idle adjustment.

Bowl

1. Carefully guide cup of accelerating pump (3) into pump well. Seat accelerating pump boot around top of accelerating pump boss.

2. Assemble washer (7) on main jet and discharge tube (6) and assemble O-ring (8) in groove near end of discharge tube.

3. Hold carburetor inverted (with float up) and rotate the long end of the spring upward so that it is against the float. Carefully position the fuel bowl on the throttle body releasing the float spring so that the long end of the spring presses against the side of the bowl (refer to Figure 3-72). Be sure that the accelerating jet fits properly in the hole in the throttle body.

4. Assemble main jet and tube (6) through hole in bottom of bowl and into throttle body boss.

5. Assemble gasket (5) on idle tube (4) and insert tube in throttle body. Carefully guide tube through bore and into discharge tube on opposite side of venturi. Tighten idle tube and main jet.

3-52

6. Attach accelerating pump lever (2) on top of accelerating pump. Other end of lever goes on rectangular end of throttle shaft. Install pump lever screw (1) in end of throttle shaft.

KEIHIN CARBURETOR - 1976 AND LATER MODELS

DESCRIPTION

The Keihin carburetor is a horizontal type with a fuel bowl, a single ring-shaped float, an accelerating pump, idle mixture adjusting needle and a throttle stop screw for idle speed adjustment.

The throttle body casting contains an integral venturi and a fuel valve seat that is pressed into the body. The underside of the throttle body contains a boss. The main jet screws into the boss and holds the bleed tube in place.

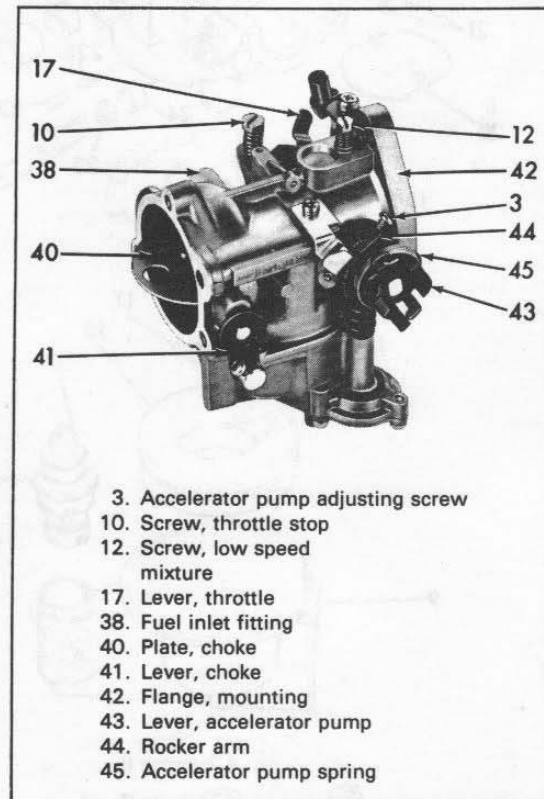

Figure 3-73. Keihin Carburetor

OPERATION

The float system is shown in Figure 3-74. Fuel from gas tank passes through fuel valve (21) into float chamber (29). The fuel entering causes float to rise until it shuts off fuel valve, stopping flow at a level pre-determined by float level setting.

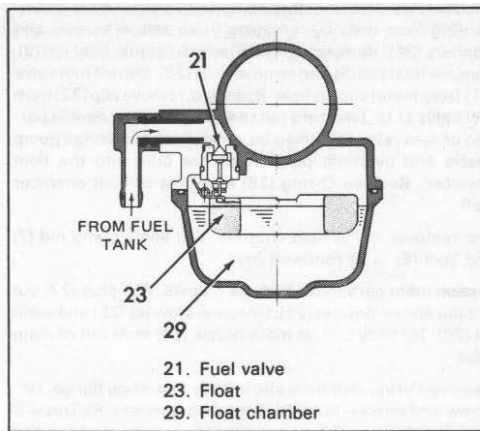

Figure 3-74. Carburetor Float System

The slow system is shown in Figure 3-75. It functions at idle, low and intermediate speeds when throttle valve is closed or only partially open. At idle, fuel enters main jet (26) and, after being metered there, enters slow jet (25) where it is metered again. The fuel from jet (25) enters bleed tube portion of slow jet where it mixes with air from slow air passage. The fuel mixture is regulated by adjusting screw (12). When throttle valve is closed, fuel mixture flows into venturi almost entirely through idle port. As throttle valve gradually opens, fuel mix discharge is transferred to bypass. Note that slow jet bleed tube is actually a part of slow jet (25).

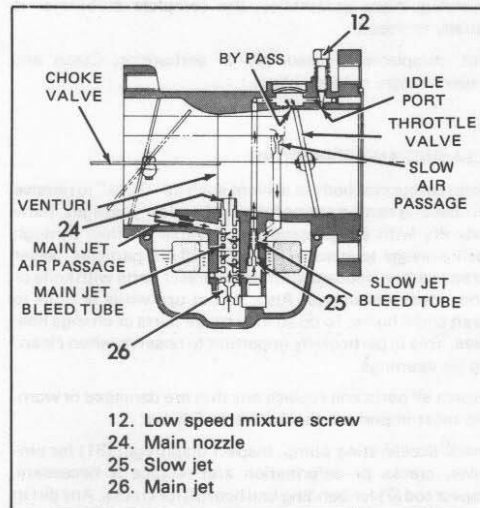

Figure 3-75. Carburetor Slow and Main System

The main system also is shown in Figure 3-75. The main system functions at intermediate and high speeds as the throttle valve opens further. The fuel is metered by main jet (26) and enters main jet bleed tube portion of main nozzle where it mixes with air entering through main jet air passage. This fuel air mixture then exits from main nozzle (24) into venturi.

The accelerating pump system is shown in Figure 3-76. It works with sudden throttle openings (rapid accelerations) to quickly inject fuel into carburetor to provide extra fuel for accelerating.

Rapid throttle action pushes pump rod (7) down, flexing diaphragm (31). This flexing action compresses fuel underneath diaphragm, forcing it up past check valve and out pump nozzle into venturi. The check valve prevents back-flow while pump nozzle meters flow. Spring action then returns diaphragm to its original position. As diaphragm returns, a new supply of fuel flows in under diaphragm so system will be ready to repeat cycle with next rapid throttle action.

The choke system, composed of choke valve and associated parts, is shown in Figure 3-75. The choke is manually set by pulling choke button out. By adjusting choke button, choke valve can be positioned either completely closed (fully choked for cold engine), partially open, or fully open (off for warm engine).

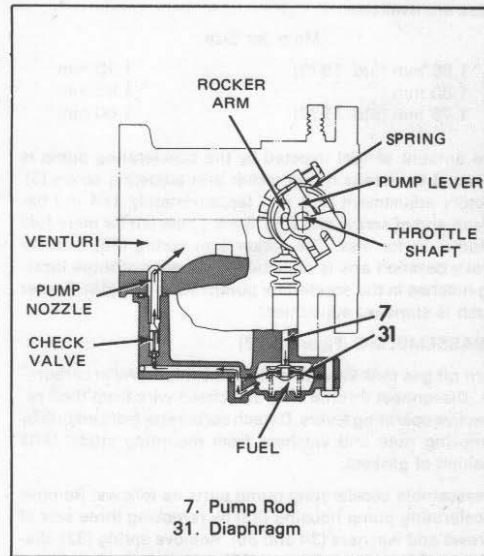

Figure 3-76. Carburetor Accelerating Pump System

ADJUSTING CARBURETOR

Refer to Figure 3-73 while performing carburetor adjustment.

Adjust carburetor as follows. Turn low speed mixture screw (12) all the way in, clockwise, until just seated. Do not over-tighten. For 1976 to early 1977 models back out $7/8$ turn. For later models, back screw out 1- $1/2$ turns. With screw in this position, the engine will start but the mixture will be too rich.

NOTE

Low speed mixture screw (12) is turned clockwise, or in, to make leaner mixture, and counterclockwise, or out, to make mixture richer. Screw is held in position by a spring (13).

Adjust throttle stop screw (10) to make engine idle at desired speed with throttle closed. Turning screw clockwise opens throttle plate for faster idle. Never set idle adjustment to slowest possible speed. An extremely slow idle causes bearing wear, oil consumption, and slow speed accelerating difficulties. Recommended idle speed is 900 rpm.

Make final readjustment on low speed mixture screw (12) after engine is warm. First turn screw in, then out, to see if engine picks up speed or runs more smoothly. Starting and all around performance will be better with mixture adjustment set slightly richer than leaner. If necessary, make further adjustment on throttle stop screw (10) to obtain correct engine idling speed.

During high speed operation, fuel is metered by a main jet (26) which has no adjustment. Operating conditions, such as high altitudes or hard service, may require a different size main jet other than the standard. The following main jet sizes are available:

Main Jet Size	
1.85 mm (Std. 1976)	1.70 mm
1.80 mm	1.65 mm
1.75 mm (Std. 1977)	1.60 mm

The amount of fuel injected by the accelerating pump is adjusted by means of the rocker arm adjusting screw (3). Factory adjustment is 6 mm (approximately $1/4$ in.) between end of screw and stop. Back screw out for more fuel volume; in for less. The rocker arm spring (45) controls stroke duration and is adjustable by means of three locating notches in the accelerator pump rocker arm (44). Center notch is standard adjustment.

DISASSEMBLING (Figure 3-77)

Turn off gas tank valve and disconnect fuel line at carburetor. Disconnect throttle wire and choke wire from their respective operating levers. Detach carburetor from engine by removing nuts and washers from mounting studs. Note position of gaskets.

Disassemble accelerating pump parts as follows: Remove accelerating pump housing (33) by removing three sets of screws and washers (34 and 35). Remove spring (32), diaphragm (31) and two O-rings (30), taking care when lifting off housing (33) to catch spring (32). Also, be careful not to damage housing mounting surface to prevent fuel leakage when reassembled.

Disassemble float chamber as follows. Detach float chamber (29) from body by removing three sets of screws and washers (34). Remove screw (6) which retains float pin (5). Remove float pin (5) and remove float (23). Slip off fuel valve (21) from metal clip on float. If needed, remove clip (22) from fuel valve (21). Take care not to damage rubber needle portion of fuel valve (21). Also be careful not to damage pump nozzle and overflow pipe which are built into the float chamber. Remove O-ring (28) from slot in float chamber wall.

The removal of the float chamber will allow pump rod (7) and boot (8) to be removed next.

Disassemble carburetor body as follows. Pull plug (27) out of tube above slow jet (25). Unscrew slow jet (25) and main jet (26). Tip body and let main nozzle (24) slide out of main tube.

Remove O-ring (20) from slot in body mounting flange. Unscrew and remove nut (19) along with washer (18). This will free throttle lever (17) and spring (16) so they can be pulled off throttle shaft.

Unscrew throttle stop screw (10) and low speed mixture screw (12) along with associated springs (11) and (13), respectively.

As required, remove brackets (2) and (15) by removing screws and washers (1) and (14), respectively.

The throttle valve assembly and choke valve assembly (shaft, valve, plate and associated parts) usually are not disassembled. These parts are matched to the individual carburetor during manufacture. In both cases, screws securing plates to shafts have peened ends, the threads of which would be destroyed if screws are removed. In the case of throttle assembly, the position of bypass hole was positioned precisely to match lip of valve and would be changed if taken apart and reassembled. If problems arise involving these assemblies, the complete carburetor is usually replaced.

This completes disassembly of carburetor. Clean and inspect before reassembling.

CLEANING AND INSPECTING

Clean carburetor body in solvent such as "Gunk" to remove varnish and carbon stains from fuel and air passages. Blow body dry with compressed air. Reverse air flow through each passage to ensure removal of all dirt particles. Never scrape carbon deposits from carburetor parts with knife or other steel instrument. Also, do not use wires or drills to clean small holes. To do so may cause burrs or change hole sizes. This is particularly important to observe when cleaning jet openings.

Inspect all parts and replace any that are damaged or worn. The most important checks are as follows:

Check accelerating pump. Inspect diaphragm (31) for pinholes, cracks or deformation and replace if necessary. Inspect rod (7) for bending and boot (8) for cracks. Any dirt in accelerating pump passage should be blown out from side opposite nozzle or check valve will close, making cleaning impossible.

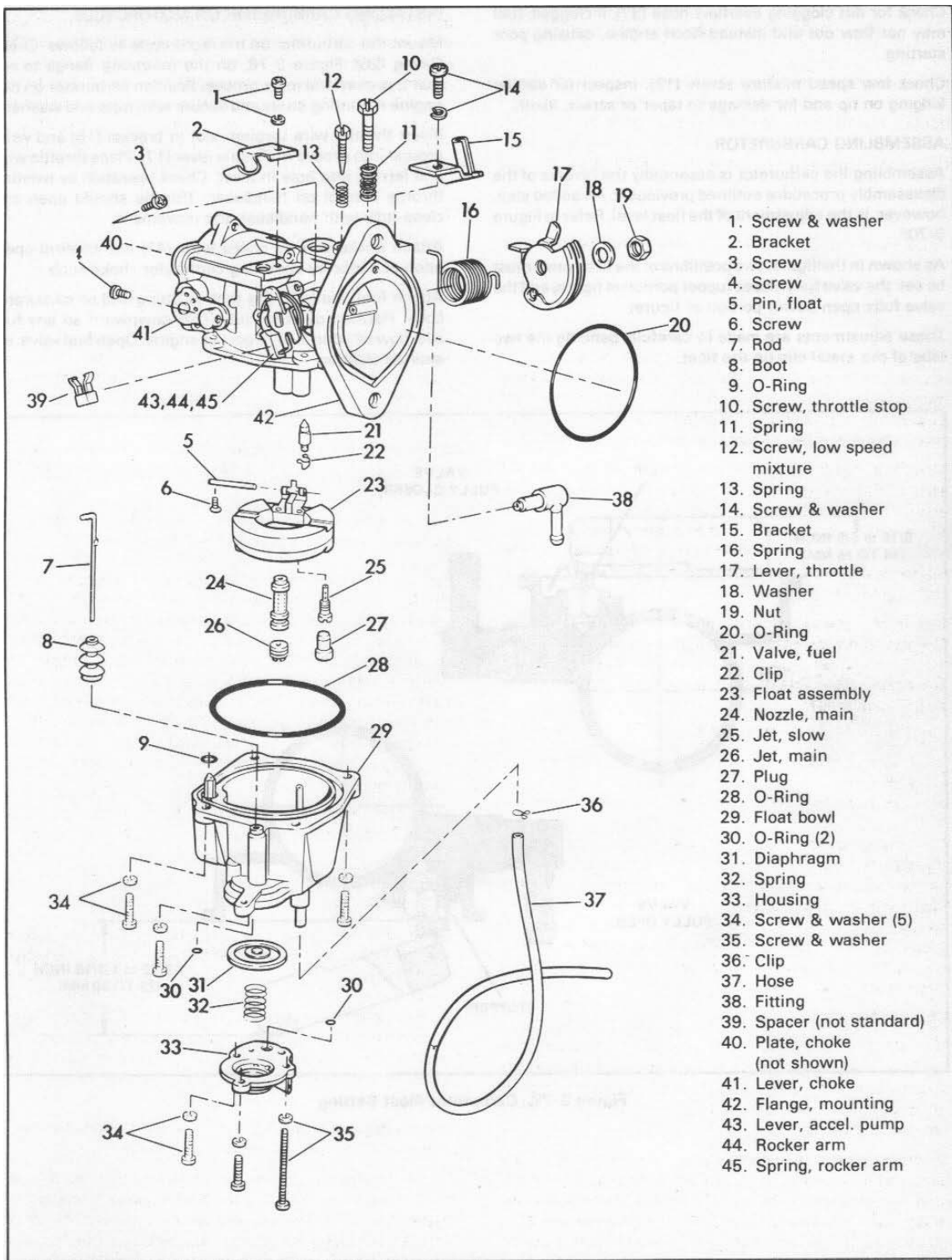

Figure 3-77. Keihin Carburetor - Exploded View

Check for dirt clogging overflow hose (37). If clogged, fuel may not flow out and instead flood engine, causing poor starting.

Check low speed mixture screw (12). Inspect for carbon lodging on tip and for damage to taper or screw, itself.

ASSEMBLING CARBURETOR

Assembling the carburetor is essentially the reverse of the disassembly procedure outlined previously. An added step, however, is the adjustment of the float level. Refer to Figure 3-70F.

As shown in the figure, two positions of the float valve must be set: the valve fully closed (upper portion of figure) and the valve fully open (lower portion of figure).

These adjustments are made by carefully bending the two tabs of the metal clip on the float.

INSTALLING CARBURETOR ON MOTORCYCLE

Mount the carburetor on the motorcycle as follows. Check O-ring (20), Figure 3-78, on the mounting flange to see that it is okay and in its groove. Position carburetor on two engine mounting studs and secure with nuts and washers.

Insert throttle wire through slot in bracket (15) and wrap around into groove in throttle lever (17). Place throttle wire end ferrule into hole in lever. Check operation by twisting throttle control on handlebar. Throttle should open and close fully with handlebar grip movement.

Attach choke wire to choke lever (41) and confirm operation of choke by operating carburetor choke knob.

Attach fuel line from gas tank to fitting (38) on carburetor body. Position overflow tube (37) downward so any fuel overflow will drip away from hot engine. Open fuel valve. Install air cleaner.

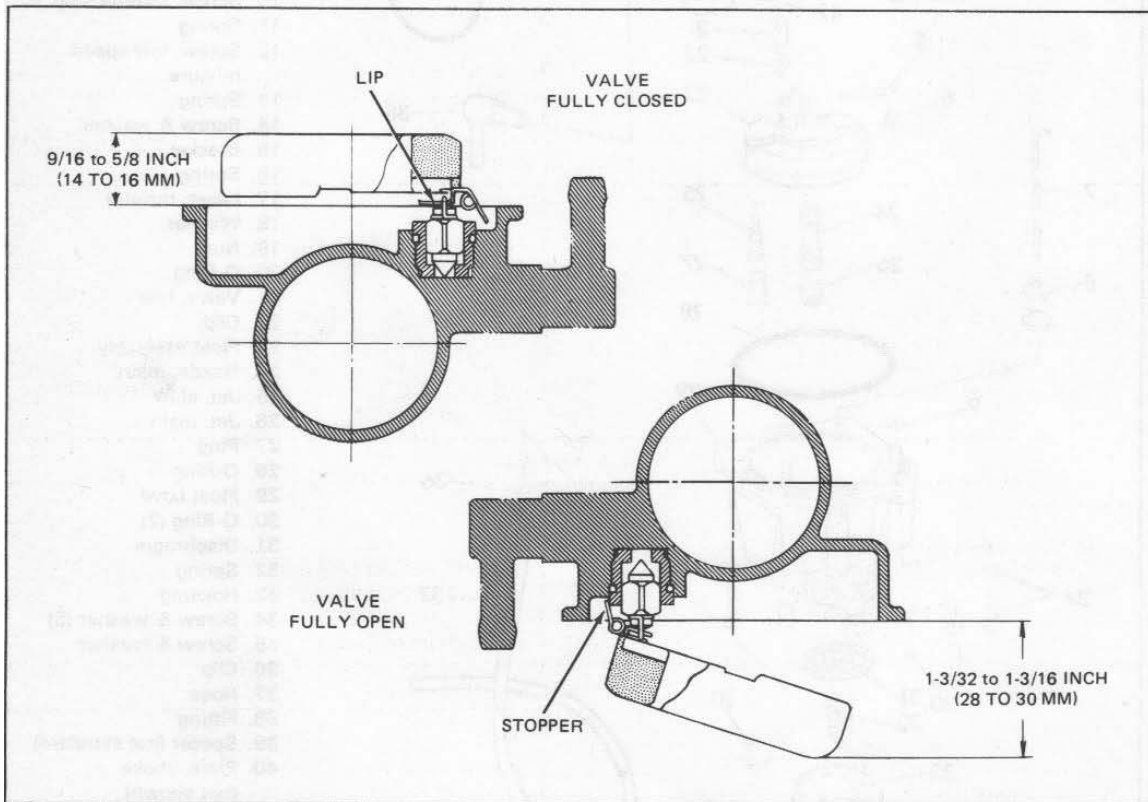

Figure 3-78. Carburetor Float Setting

KEIHIN CARBURETOR TROUBLE CHART

Overflow	
<p>Check for:</p> <ol style="list-style-type: none"> 1. Worn fuel valve (21) or dirty fuel valve seat. 2. Improper fuel level in float chamber (29). 3. Worn float (23) mounting tabs. 4. Worn float pin (5) or loose screw (6). 5. Damaged float chamber O-ring (28). 6. Loose float chamber screws (34). 7. Deformed float (23). 	<p>Remedy:</p> <ol style="list-style-type: none"> 1. Replace valve (21) or clean valve seat. 2. Adjust float (29) mounting tabs for correct fuel level. 3. Replace float (23). 4. Replace pin (5) or tighten screw (6). 5. Replace O-ring (28). 6. Tighten screws (34). 7. Replace float (23).
Poor Idling	
<p>Check for:</p> <ol style="list-style-type: none"> 1. Idling improperly adjusted. 2. Damaged low speed mixture screw (12). 3. Clogged bypass or idle port. 4. Clogged slow jet (25). 5. Loose slow jet (25). 6. Air leaking into system. 7. Excessive fuel from accelerating pump. 	<p>Remedy:</p> <ol style="list-style-type: none"> 1. Adjust idle. 2. Replace screw (12). 3. Clean. 4. Clean jet (25). 5. Tighten jet (25). 6. Replace O-ring (20) and tighten mounting screws. 7. Check accelerating pump rod (7) length.
Poor Fuel Economy	
<p>Check for:</p> <ol style="list-style-type: none"> 1. Fuel level too high. 2. Clogged bleed tubes (24) and (25). 3. Loose jets. 4. Idling improperly adjusted. 5. Choke not opening fully. 6. Dirty air cleaner. 7. Excessive fuel from accelerating pump. 	<p>Remedy:</p> <ol style="list-style-type: none"> 1. Adjust level of float (23). 2. Clean. 3. Tighten. 4. Adjust idle. 5. Inspect choke and choke wire and adjust. 6. Clean. 7. Adjust fuel flow. Check accelerating pump rod (7) length.
Poor Acceleration	
<p>Check for:</p> <ol style="list-style-type: none"> 1. Clogged accelerating system. 2. Damaged accelerating pump diaphragm (31). 3. Slow system improperly adjusted. 4. Clogged slow jet (25) or bleed tube. 5. Fuel level too low. 	<p>Remedy:</p> <ol style="list-style-type: none"> 1. Clean. 2. Replace diaphragm (31). 3. Adjust slow system. 4. Clean. 5. Adjust level of float (23).
Hard Starting	
<p>Check for:</p> <ol style="list-style-type: none"> 1. Choke valve (41) not operating properly. 2. Idling improperly adjusted. 3. Generally dirty carburetor. 4. Loose carburetor mounting nuts. 5. Fuel overflow. 	<p>Remedy:</p> <ol style="list-style-type: none"> 1. Adjust choke system. 2. Adjust idle. 3. Disassemble and clean. 4. Tighten mounting nuts. 5. Inspect float (23) and fuel valve (21) and adjust or replace.

KEIHIN CARBURETOR TROUBLE CHART (CONT.)

Poor Performance On Road	
<p>Check for:</p> <ol style="list-style-type: none"> 1. Idling improperly adjusted. 2. Fuel overflow. 3. Main jet (26) loosened. 4. Damaged O-ring (20). 5. Faulty operation of accelerating pump. 6. Air leak in intake system. 	<p>Remedy:</p> <ol style="list-style-type: none"> 1. Adjust idle. 2. Inspect float (23) and fuel valve (21) and adjust or replace. 3. Inspect main jet (26) and tighten. 4. Replace O-ring (20). 5. Correct rod (7) length. 6. Check air cleaner backing plate and manifold mounting.
Poor High Speed Performance	
<p>Check for:</p> <ol style="list-style-type: none"> 1. Loose main jet (26). 2. Improper fuel level in float chamber (29). 3. Dirt lodged in strainer in fuel tank. 4. Clogged main jet (26) or main jet air passage. 	<p>Remedy:</p> <ol style="list-style-type: none"> 1. Inspect main jet (26) and tighten. 2. Adjust float (23) mounting tabs for correct fuel level. 3. Clean strainer. 4. Clean.
Abnormal Combustion (Fuel Mixture)	
<p>Check for:</p> <ol style="list-style-type: none"> 1. Incorrect fuel mixture. 2. Generally dirty carburetor. 3. Dirty or clogged fuel line. 4. Air leaking into system. 	<p>Remedy:</p> <ol style="list-style-type: none"> 1. Adjust carburetor. 2. Disassemble and clean. 3. Clean fuel line or replace. 4. Check mounting nuts for tightness or replace O-ring (20).
Loss of Power (Fuel Insufficient)	
<p>Check for:</p> <ol style="list-style-type: none"> 1. Generally dirty carburetor. 2. Clogged fuel line. 3. Dirty fuel tank. 4. Air leaking into system. 5. Accelerating pump not working. 6. Clogged fuel strainer in fuel tank. 	<p>Remedy:</p> <ol style="list-style-type: none"> 1. Disassemble and clean. 2. Clean. 3. Clean. 4. Check mounting nuts for tightness or replace O-ring (20). 5. Repair and adjust. 6. Clean strainer.
Loss of Power (Air Insufficient)	
<p>Check for:</p> <ol style="list-style-type: none"> 1. Dirty air cleaner. 2. Throttle cable not working. 	<p>Remedy:</p> <ol style="list-style-type: none"> 1. Clean air cleaner. 2. Check and repair throttle cable.

AIR CLEANER

The air cleaner consists of a backing plate, filter element and cover, arranged so all air drawn into carburetor passes through the filter. A mesh element traps all airborne dust to keep it from entering carburetor and engine.

METAL MESH TYPE FILTER ELEMENT

In normal service on hard surfaced roads, remove air cleaner mesh, wash in a non-flammable petroleum solvent or detergent and water, and saturate with engine oil at least every 1000 miles, or oftener under dusty service conditions. In extremely dusty service, clean and oil filter mesh every 100 miles or at least once a day.

PLASTIC FOAM TYPE FILTER ELEMENT

Carburetor air cleaner (1972 and later) is equipped with a plastic foam air filter element which is oil saturated.

Remove air cleaner cover and inspect filter element at least every 1000 miles, or oftener under dusty service conditions. The need for servicing is indicated by the appearance of the outside surface of the filter. Filter should be cleaned and recoiled if a film of dirt has built up covering the surface pores, or if light spots show on the surface which means that dust is drying out the oil. A dirty, dark appearance is normal, as long as pores in the filter remain open and covered with an oil film.

To clean filter, remove it from screen and wash it in a non-flammable petroleum solvent or detergent and water. Allow to dry thoroughly and saturate with same weight oil as recommended for engine crankcase. Apply oil to element liberally working in with hands and fingers until element is uniform in color indicating uniform saturation. After excess oil has drained off, replace element on screen so that three grooves are toward screen, and reinstall in engine.

FUEL TANK

GENERAL

The fuel tanks are of welded steel construction.

Fuel tanks are treated to resist rusting. However, when motorcycle stands unoperated for any length of time (e.g. over Winter), tanks should be drained and the tank interior bathed with an oil fuel mixture of equal proportions. The fuel will evaporate leaving a protective oil film on tank walls. Moisture formation and subsequent damage may also be avoided by using only "good grade" anti-knock ethyl fuels with moisture absorbing additives.

REPAIRING LEAKING TANKS

Many tank leaks may be repaired with epoxy type materials. Follow manufacturers instructions.

Tank leaks may be arc welded, gas welded or soldered. However, only firms or persons qualified to make such repairs should be entrusted with the operation.

WARNING — If ALL traces of fuel are not purged, an open flame repair may result in a tank explosion. Extreme caution in all tank repair is recommended.

FUEL SUPPLY VALVE

The fuel supply valve is located under the fuel tank. Two types are used: type A (1974 & Earlier) and type B (1975 & Later). Both are covered below under separate headings.

TYPE A VALVE (1974 & Earlier) (Figure 3-79)

The valve has two handles: one is marked "reserve" and the other is unmarked. Fuel to carburetor is shut off when both handles are in horizontal position. Turning the unmarked handle to vertical position turns on main fuel supply; turning "reserve" handle to vertical position turns on reserve supply.

If the handle is too loose, add enough .006 in. thick shims, Part No. 6160P, to provide only slight clearance when valve is closed.

The fuel strainer is located on top of the supply valve inside the fuel tank. If the supply of fuel is impeded, as indicated by irregular carburetion, remove the supply valve from the tank and thoroughly clean the strainer. Be sure to drain the tank before removing the supply valve.

Before installing supply valve, coat threads with a fuel sealer.

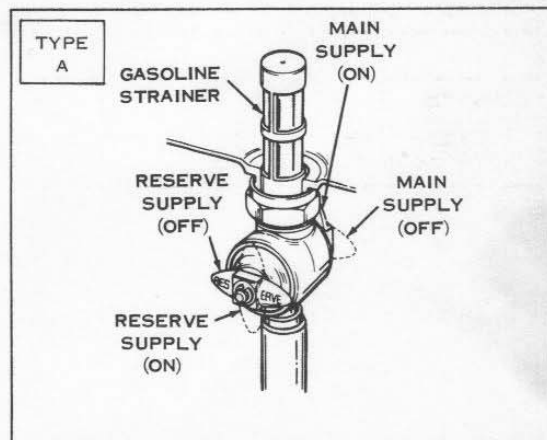

Figure 3-79. Diaphragm Type Fuel Supply Valve and Strainer

TYPE B VALVE (1975 & Later) (Figure 3-80)

The fuel supply valve is located under the fuel tank. Gasoline to carburetor is shut off when the handle is in a horizontal position. Turning the handle down to vertical position turns on the main gasoline supply; turning the handle up to the vertical position turns on the reverse supply. Valve should always be in the off position when the engine is not running.

A fuel strainer is located on top of the supply valve inside the fuel tank. When fuel flow restriction is suspected, remove hose at carburetor and open valve to the reserve position to drain fuel into a suitable container.

WARNING — Gasoline is extremely flammable and highly explosive under certain conditions. Do not smoke or allow open flame or sparks when refueling or servicing the fuel system.

Remove fitting from tank, clean or replace screen and flush tank to remove all dirt. Before reinstalling, coat threads with Harley-Davidson Pipe Sealant with Teflon, Part No. 99630-77.

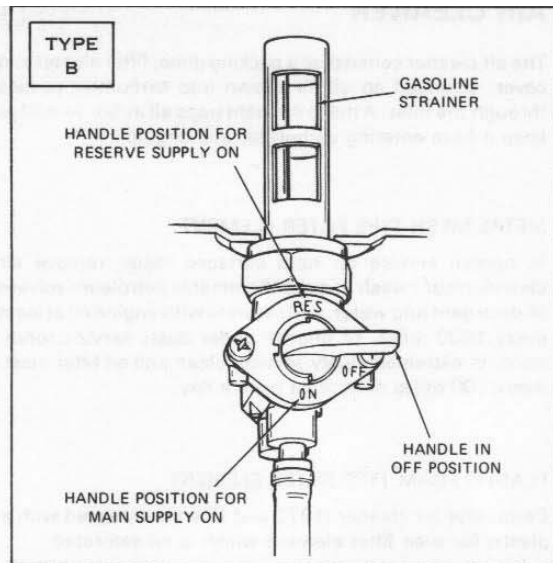
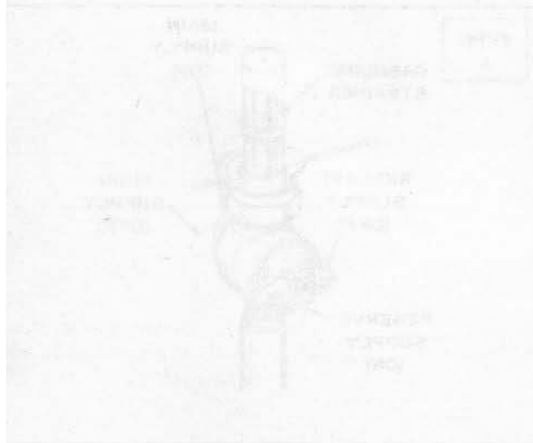
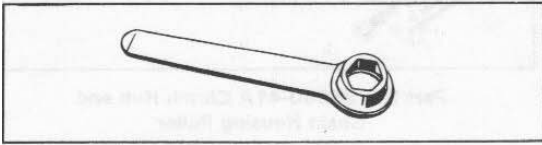

Figure 3-80. Single Handle Type Fuel Supply Valve and Strainer



TOOLS



Part No. 94545-26 Sprocket Nut Wrench

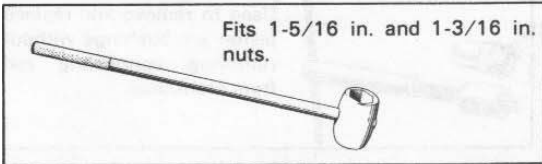

Fits 1-5/16 in. and 1-3/16 in. nuts.

Part No. 94546-41 Flywheel Shaft Nut Wrench

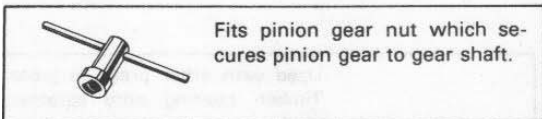

Fits pinion gear nut which secures pinion gear to gear shaft.

Part No. 94555-55 Gear Shaft Nut Socket Wrench

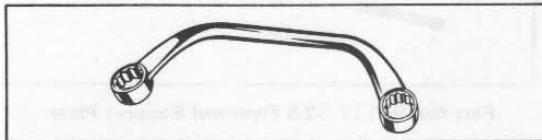

Part No. 94585-30 Cylinder Base Nut Wrench (5/8 in.)

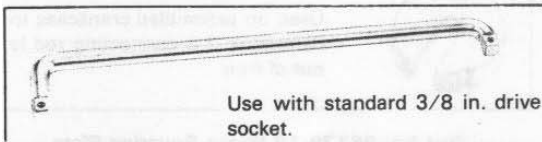

Use with standard 3/8 in. drive socket.

Part No. 94590-73 Cylinder Head Bolt Socket Handle (3/8 in. Square Drive)

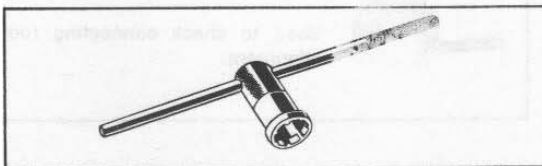

Part No. 94645-41 Clutch Hub Nut Wrench

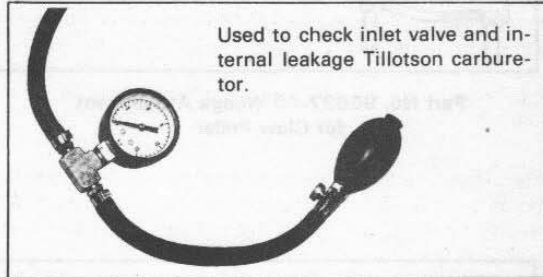

Used to check inlet valve and internal leakage Tillotson carburetor.

Part No. 94750-68 Carburetor Leakage Tester

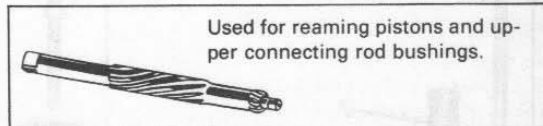

Used for reaming pistons and upper connecting rod bushings.

Part No. 94800-26 Spiral Expansion Reamer

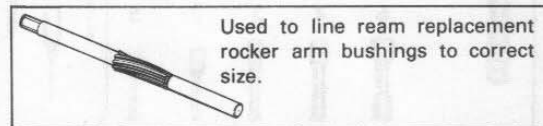

Used to line ream replacement rocker arm bushings to correct size.

Part No. 94804-57 Rocker Arm Bushing Reamer

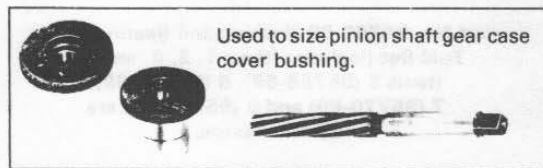

Used to size pinion shaft gear case cover bushing.

Part No. 94805-57 Pinion Shaft Bushing Reamer and Pilots

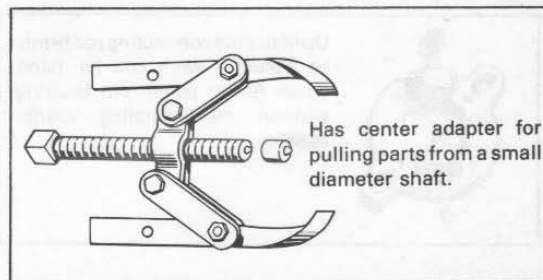

Has center adapter for pulling parts from a small diameter shaft.

Part No. 95635-46 All Purpose Claw Puller

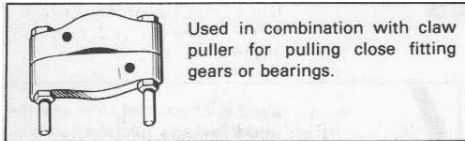

Used in combination with claw puller for pulling close fitting gears or bearings.

Part No. 95637-46 Wedge Attachment for Claw Puller

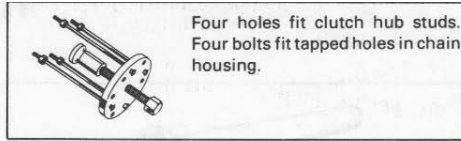

Four holes fit clutch hub studs. Four bolts fit tapped holes in chain housing.

Part No. 95960-41A Clutch Hub and Chain Housing Puller

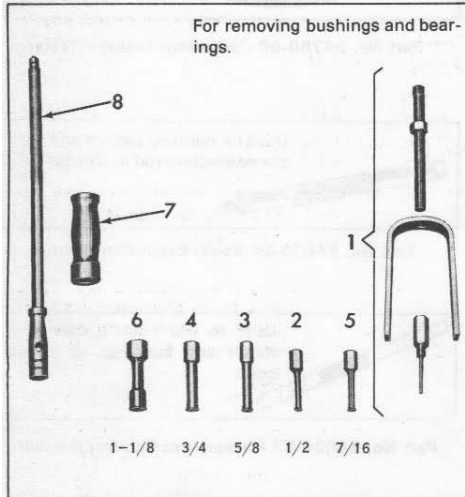

For removing bushings and bearings.

Part No. 94760-69 Bushing and Bearing Puller Tool Set (Includes items 1, 2, 3, and 4). Items 5 (95768-69), 6 (95769-69), 7 (95770-69) and 8 (95771-69) are optional extras.

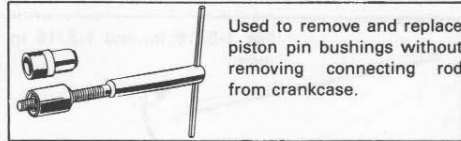

Used to remove and replace piston pin bushings without removing connecting rod from crankcase.

Part No. 95970-32A Piston Pin Bushing Tool

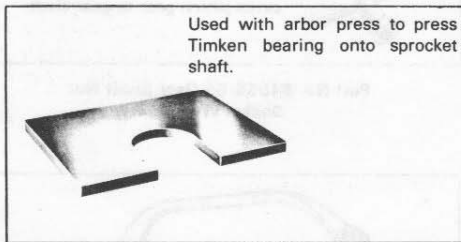

Used with arbor press to press Timken bearing onto sprocket shaft.

Part No. 96137-52A Flywheel Support Plate

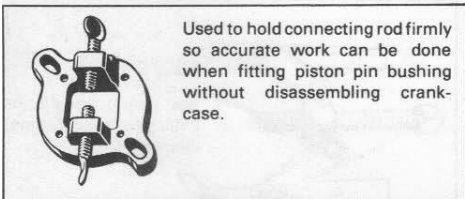

Used to hold connecting rod firmly so accurate work can be done when fitting piston pin bushing without disassembling crankcase.

Part No. 95952-33 Connecting Rod Clamping Tool

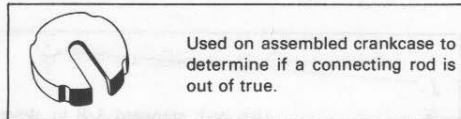

Used on assembled crankcase to determine if a connecting rod is out of true.

Part No. 96179-18 Piston Squaring Plate

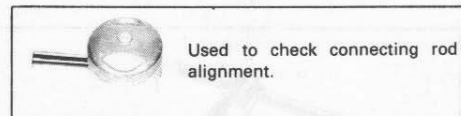

Used to check connecting rod alignment.

Part No. 96180-76 Special Piston with Pin

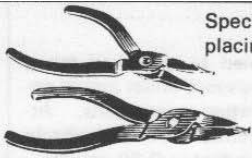

Special pliers for removing and replacing retaining rings.

96215-49 Small
96216-49 Large

Internal Lock Ring Pliers

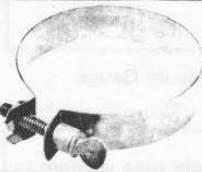

Used to insert pistons with rings into cylinders. Tool compresses rings to bore size.

Part No. 96333-51A Piston Inserter Ring Tools

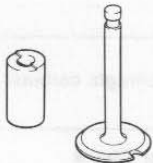

For checking valve seat location on 74-OHV models. Tool consists of two valves and gauge having a step to show limits to which valve seat should be ground.

Part No. 96490-59A Valve Seating Gauge Seat

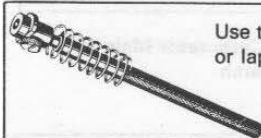

Use to rotate valve when grinding or lapping seat surfaces.

Part No. 96550-36 Valve Lapping Tool

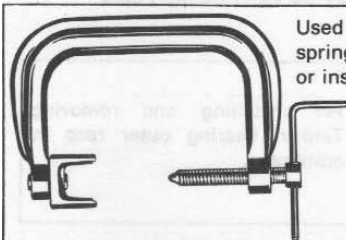

Used to compress valve springs while removing or installing valves.

Part No. 96600-36 Valve Spring Compressor

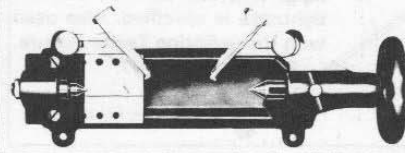

Used to true flywheel shaft alignment. Measures and indicates alignment of .001 in.

Part No. 96650-30 Truing Stand

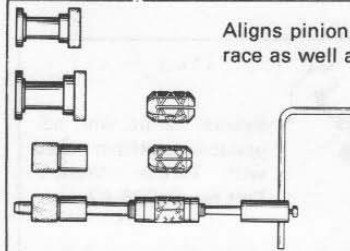

Aligns pinion shaft main bearing race as well as lapping to size.

Part No. 96710-40 Crankcase Main Bearing Lap

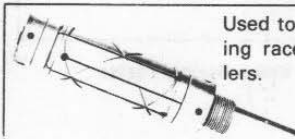

Used to lap connecting rod bearing races when fitting new rollers.

Part No. 96740-36 Connecting Rod Lapping Arbor

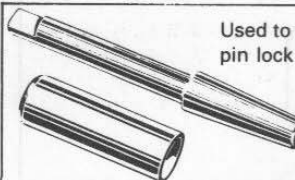

Used to remove and install piston pin lock rings (1972 and earlier).

Part No. 96780-32A Piston Lock Ring Tool

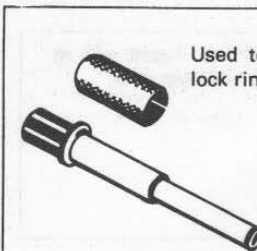

Used to install spiral piston pin lock rings (1973 and early 1977).

Part No. 96780-58A Piston Pin Lock Ring Tool

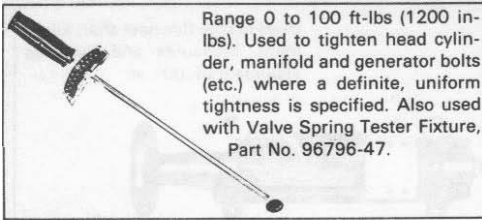

Range 0 to 100 ft-lbs (1200 in-lbs). Used to tighten head cylinder, manifold and generator bolts (etc.) where a definite, uniform tightness is specified. Also used with Valve Spring Tester Fixture, Part No. 96796-47.

Part No. 96795-47 Torque Wrench

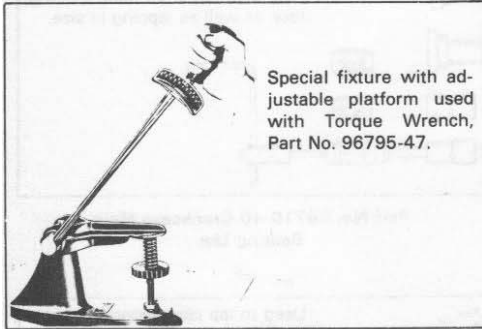

Special fixture with adjustable platform used with Torque Wrench, Part No. 96795-47.

Part No. 96796-47 Valve Spring Tester

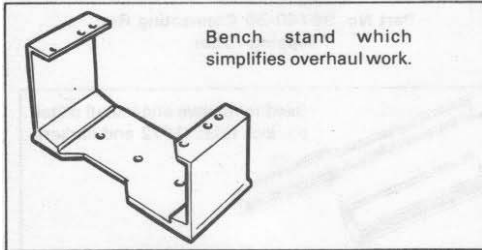

Bench stand which simplifies overhaul work.

Part No. 96815-46 Engine Repair Stand

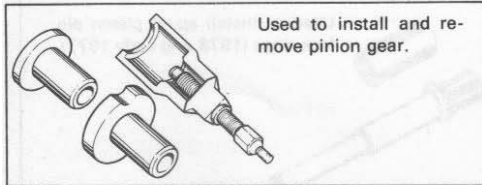

Used to install and remove pinion gear.

Part No. 96830-51 Pinion Gear Puller and Collars

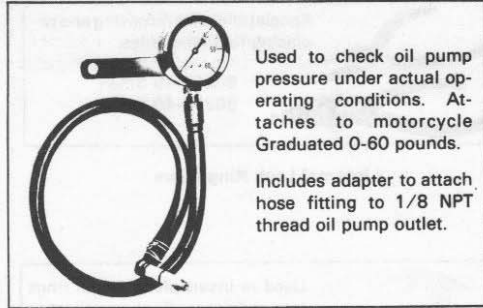

Used to check oil pump pressure under actual operating conditions. Attaches to motorcycle Graduated 0-60 pounds.

Includes adapter to attach hose fitting to 1/8 NPT thread oil pump outlet.

Part No. 96921-52 Oil Pressure Gauge

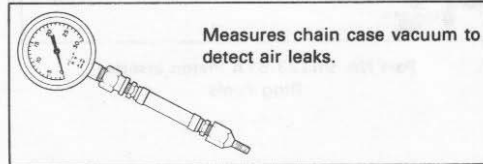

Measures chain case vacuum to detect air leaks.

Part No. 96950-68 Vacuum Gauge, 30 in. Water

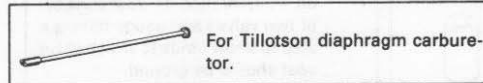

For Tillotson diaphragm carburetor.

Part No. 96960-68 Carburetor Check Valve Tool

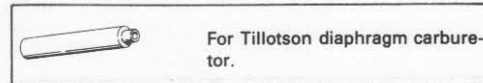

For Tillotson diaphragm carburetor.

Part No. 96962-68 Carburetor Main Nozzle Patch

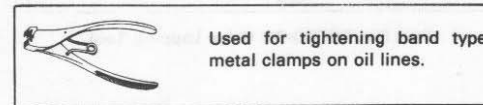

Used for tightening band type metal clamps on oil lines.

Part No. 97087-65 Hose Clamp Pliers

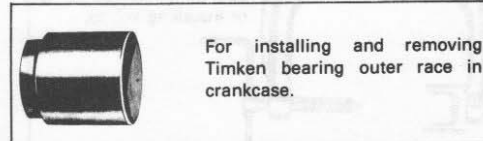

For installing and removing Timken bearing outer race in crankcase.

Part No. 97194-57 Timken Bearing Outer Race Press Plug

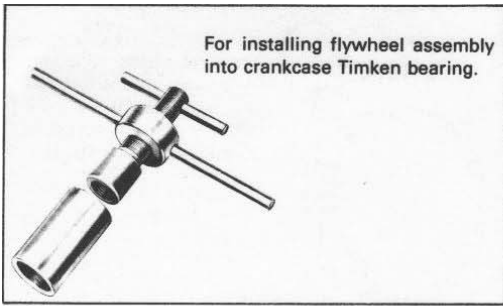

Part No. 97225-55 Sprocket Shaft Bearing Tool

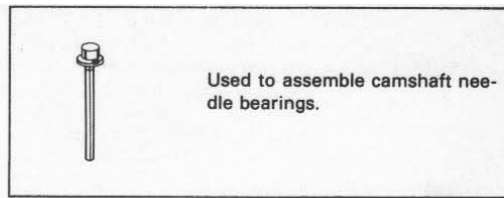

Part No. 97272-60 Needle Bearing Tool

TABLE OF CONTENTS

	PAGE
General	4-1
Clutch	4-3
Electric Starter	4-7
Kick Starter	4-9
Gear Box	4-11
Tools	4-23

GENERAL

SPECIFICATIONS

CLUTCH

Type	Dry-multiple disc
Capacity	206 ft-lb torque
Spring pressure (total)	315 lbs
Roller bearing fit002-.003 in. loose
Spring adjustment	1-1/32 in. from spring collar edge to outer disc surface

CHAIN

Type (primary)	1/2 in. pitch, double
Looseness	1/2 to 15/16 in. slack (cold engine)

MAINSHAFT MAIN DRIVE GEAR

Roller bearing0005-.0019 in. loose
Inner bearing00175-.00325 in. loose
Drive gear end play0025-.0135 in.

MAINSHAFT

Low gear end bearing	
In housing0013 in. loose-.0001 in. press
On shaft001 in. loose-.0007 in. press
Housing in case0005 in. loose-.0010 in. press
Third gear	
End play000 to .017 in.
Bushing on shaft0012-.0023 in. loose
Bushing in gear	Press fit

COUNTERSHAFT

Drive gear end bearing0005-.0019 in. loose
Low gear end bearing0005-.0019 in. loose
Gear end play007-.012 in.
Second gear	
End play003-.017 in.
Bushing on shaft000-.0015 in. loose
Bushing in gear0005-.0025 in. loose
Low gear	
Bushing on shaft000-.0015 in. loose
Bushing in gear0005-.0025 in. loose
Shifter clutch	
Low and second080-.090 in.
Third and high100-.110 in.
Sliding reverse gear060-.070 in.
Gear backlash003-.006 in.

SHIFTER CAM

End play0005-.0065 in.
----------------	-----------------

DESCRIPTION

The transmission has four major assemblies, the clutch, gear box, gear shifter and starter. Each is a part of power transmission from engine to rear wheel or a means of power control.

CLUTCH

The clutch is made up of a drum or shell which is integral with the rear primary drive chain sprocket and which has inside a series of alternately positioned lined and unlined discs. The lined discs are doweled to the clutch hub which is keyed to the transmission shaft while the steel (unlined) discs are keyed to the clutch shell. When the clutch pressure plate is seated, a group of springs press the steel and lined discs together making a non-slipping connection between the engine and transmission.

GEAR BOX

The gear box contains a series of gears on a mainshaft and countershaft which may be powered in a selection of ratios according to speed and load requirements.

GEAR SHIFTER

The gear shifter is a unit mounted to the gear box which shifts the gear box components into desired ratios by means of shifting forks that slide shifter clutches into and out of mesh along shafts.

STARTER

Electric starter motor and Bendix type drive unit engages a ring gear on the clutch. The primary chain transmits the force through the front sprocket.

REPAIR PROCEDURE

When operating troubles develop in a transmission component, it is recommended procedure to first check following adjustments. If adjustments do not remedy the trouble, then proceed to disassembly and repair procedures.

1. Adjusting Clutch Control
2. Adjusting Clutch
3. Adjusting Shifting Linkage
4. Adjusting Foot Shifter Cover

If above adjustments do not correct trouble, disassemble and repair as described in repair sections. See "Locating Operating Troubles," Section 1, for aids to diagnosing trouble. It is not necessary to remove transmission from chassis to disassemble clutch, starter, transmission mainshaft, ball bearing, main drive gear oil seal or clutch release mechanism. However, extensive repairs are often easier and more quickly made if transmission unit is removed to bench as described in following section, "Stripping Motorcycle for Transmission Repair."

STRIPPING MOTORCYCLE FOR TRANSMISSION REPAIR

1. Remove battery ground wire and battery. Remove foot shifter lever and cover plate. Remove chain housing cover. Remove compensating sprocket nut.
2. Remove clutch as described in "Disassembling Clutch."

3. Remove mainshaft key. Loosen the five transmission base mounting nuts. Remove the four bolts attaching chain housing to engine crankcase and four bolts attaching housing to transmission. Remove the two chain housing stud nuts attaching starter housing to chain guard. Remove wires connected to starter solenoid terminals. Pull inner chain housing loose from mainshaft using Puller, Part No. 95960-41A, which has four screws to fit tapped holes in chain housing. Care must be taken to be sure housing moves out squarely as front end is snug fit on shoulder of crankcase. As housing is pulled out, shake starter assembly shaft to free it from gear in starter motor housing. Remove chain oiler hose at oil pump. Remove chain housing oil return hose at rear of chain guard and vent hose at T-connection and move housing away. On FX, remove foot shifter lever linkage from chain housing and shifter pawl lever on transmission cover. Remove battery carrier bracket from right side of transmission. Remove right Buddy Seat foot-rest bracket. Remove starter motor bracket and pull starter motor out left side.

4. Disconnect clutch cable from clutch release arm.
5. Disconnect shifter rod from transmission cover by removing nut and bolt or cotter pin and clevis pin.
6. Remove exhaust pipe.
7. Disconnect speedometer drive cable and housing from transmission. Disconnect neutral indicator switch wire clip.
8. Remove rear chain connecting link and chain. Remove bolt which secures transmission to support bracket on right side of frame.

9. Remove bolts and cap screws, which secure transmission mounting plate to chassis.

10. Remove complete transmission with mounting plate.

Reassembly is the reverse of disassembly with the following exceptions:

The four nuts securing the transmission to mounting plate as well as the bolt which secures transmission to frame support bracket should be left loose to facilitate easy alignment of the chain housing with engine crankcase and transmission bolts.

Primary chain case bolts on engine and transmission should be tightened evenly to 18 to 22 ft-lbs torque so housing does not bind on transmission mainshaft or shoulder on engine crankcase. Final tightening should start at three bolts at engine crankcase, then four bolts at transmission, then four base mounting nuts and bolts securing transmission to chassis bracket.

IMPORTANT

After reassembly, chain housing must be air tight. Check using Vacuum Gauge, Part No. 96950-68. Remove one of the four screws securing the front chain inspection cover and in its place screw in the threaded fitting of the gauge. Then, with engine running, check gauge to see that there is a reading indicating 20 inches water pressure or more at 1500 rpm. Perform check with vent hose to tank pinched closed with a pliers. A lower reading indicates an air leak into chain housing either at gasket, solenoid, starter shaft, or hoses.

CLUTCH

GENERAL

The clutch or clutch control mechanism needs attention when the clutch slips under load, or drags in released position. For causes of slipping clutch see "Locating Operating Troubles," Section 1. Before disassembling clutch when repair is indicated, readjust gear shifter control and clutch spring tension. It is not necessary to remove transmission from chassis to adjust or repair clutch.

ADJUSTING FOOT CLUTCH CONTROL (Figure 4-2)

With foot pedal in fully disengaged position (heel down), the clutch lever should strike the transmission case cover. Adjust length of the foot pedal rod to just clear the foot pedal bearing cover so the rod is not bent down by the bearing cover.

Move the foot pedal to a toe down or fully engaged position, loosen the locknut (4) and readjust the push rod adjusting screw (5) with a screwdriver so that the end of the clutch lever (8) has about 1/8 in. free movement before clutch disengages. Turn screw (5) right for less movement and left, for more.

ADJUSTING HAND CLUTCH CONTROL (Figure 4-2)

Adjust control cable sleeve (1) as required to maintain approximately 1/4 in. free hand lever movement before clutch starts to disengage. To adjust, loosen adjusting sleeve locknut (2) turn threaded sleeve out for less hand lever free play or into bracket (3) for more hand lever free play and re-tighten locknut.

If sleeve adjustment has been all taken up or there are other indications of incorrect clutch operation such as slipping clutch, gear clash due to dragging clutch when shifting, the following adjustments should be made in the order shown.

Move end of lever on transmission forward until it becomes firm indicating that all slack in the actuating mechanism has been taken up.

Measure clearance between starter motor (7) and clutch release lever (8) which should be 3/8 to 5/8 in. If not within this range, adjust as follows:

Loosen control coil adjusting sleeve locknut (2) (Figure 4-2) and turn control coil adjusting sleeve (1) all the way into bracket. Remove chain housing cover, loosen clutch push rod screw locknut (4) and turn screw (5) in (clockwise) to remove lever (8) to the rear, or outward (counterclockwise) to move end of lever forward. When 1/2 in. clearance between lever and starter motor has been attained, tighten locknut (4) and reinstall chain housing cover.

IMPORTANT

Chain housing must be airtight with cover reinstalled
- use new cover gasket and gasket sealer.

Adjust clutch hand lever for 1/4 in. free movement as described above.

To disassemble cable from hand lever at anchor pin, turn sleeve into bracket (3) and remove cable from side slot as shown in Figure 4-1. When reassembling cable ferrule in hand lever anchor pin with side slot, be sure slot is toward inside as shown.

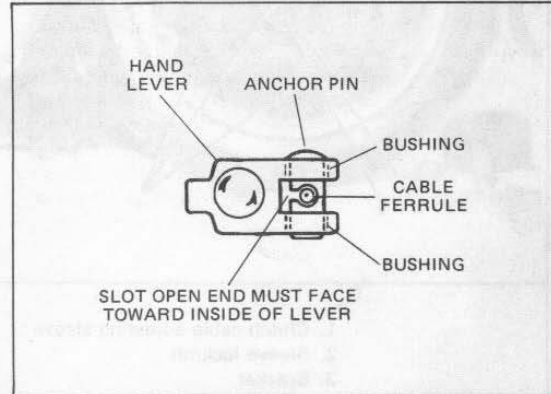

Figure 4-1. Clutch Hand Lever Cable

ADJUSTING CLUTCH

If the clutch slips after adjusting clutch control, increase spring tension on the three clutch spring guide stud nuts (6, Figure 4-2). Remove clutch cover and tighten all three nuts one-half turn at a time until clutch holds. Test after each half turn by cranking the engine. Usually a clutch that holds without noticeable slipping when cranking the engine will hold under normal road conditions. Do not increase spring tension any more than is necessary to make clutch hold.

A new clutch is assembled so the distance from inner edge of spring collar (2, Figure 4-3) to the surface of the outer disc (8) is exactly 1-1/32 in. If springs are compressed so this distance is 7/8 in. or less, the clutch probably cannot be fully disengaged. Check the dimension at several points to make sure that releasing disc is parallel with plates.

When clutch will not hold without tightening beyond this limit, disassemble the clutch for inspection of the clutch discs. Discs may be worn or oil soaked and in need of replacement or washing.

DISASSEMBLING CLUTCH (Figure 4-4)

Remove primary chain housing cover.

Remove push rod adjusting screw locknut (1). Place a flat washer about 1/8 in. thick with 1-3/4 in. outside diameter and 3/8 in. hole over the adjusting screw (2). Replace locknut and turn down until three spring tension adjusting nuts (3) are free. The nuts may then be removed and the spring collar, springs, outer disc assembly (4, 5 and 6) may be slipped off clutch hub dowels and studs as shown in Figure 4-3. Do not disassemble these parts unless necessary for spring, spring collar or outer disc replacement.

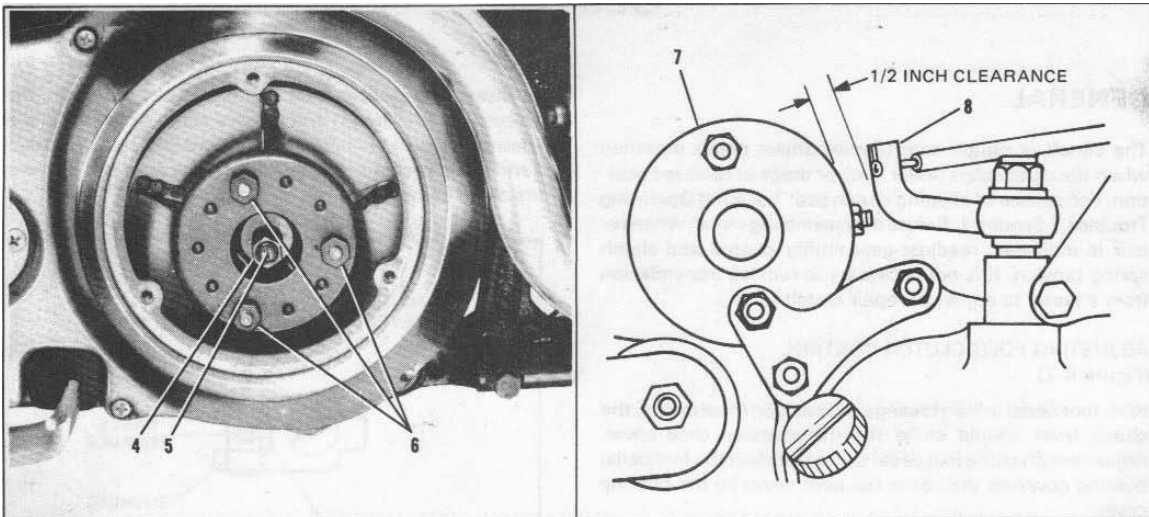

- | | |
|---|---------------------------------|
| 1. Clutch cable adjusting sleeve | 5. Clutch adjusting screw |
| 2. Sleeve locknut | 6. Clutch spring adjusting nuts |
| 3. Bracket | 7. Starter motor |
| 4. Clutch push rod adjusting screw lock | 8. Clutch release lever |

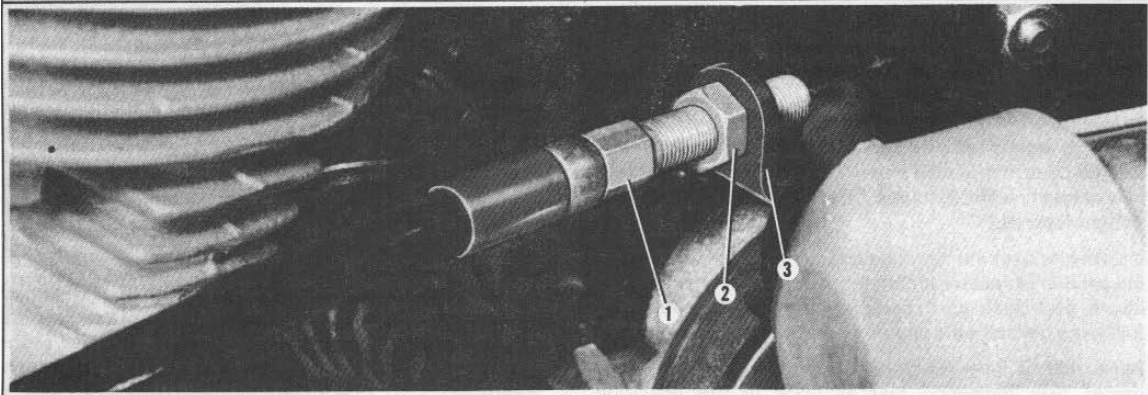

Figure 4-2. Adjusting Clutch

Remove steel discs (7) and lined friction discs (8).

Remove primary chain adjuster.

Remove engine compensating sprocket nut.

Remove clutch shell (9), compensating sprocket and primary chain from clutch hub.

Pry back ear on clutch hub nut lockwasher. Remove clutch hub nut (10) using Clutch Hub Nut Wrench, Part No. 94645-41. Thread is left hand. Remove clutch hub nut lockwasher (11).

4-4

NOTE

When disassembling clutch on 1976 and later, it is not possible to remove clutch push rod (4, Figure 4-6A) from clutch side of transmission, because it is retained by a lock ring (3E, Figure 4-6A). Therefore, on these models, it is necessary to use puller 95900-41A to remove clutch hub to protect the clutch push rod end from damage.

Remove clutch hub (12) using Clutch Hub Puller, Part No. 95960-41A. Turn tool center bolt back until puller plate may be slipped over clutch hub studs and against ends of clutch hub pins. Secure puller plate with the three clutch spring guide stud nuts. Turn down tool center screw until clutch hub breaks free from gear box shaft taper. Remove clutch hub key (13).

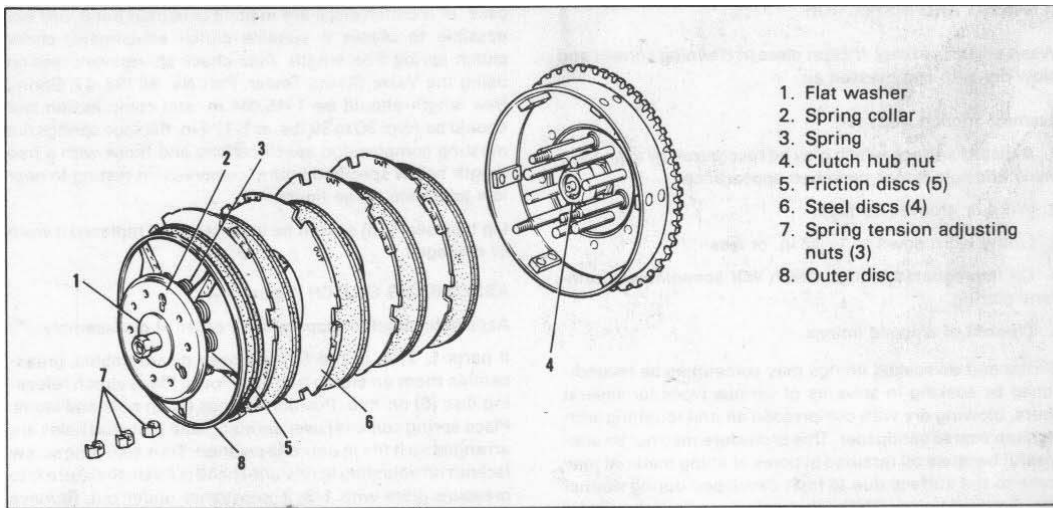

Figure 4-3. Removing Clutch

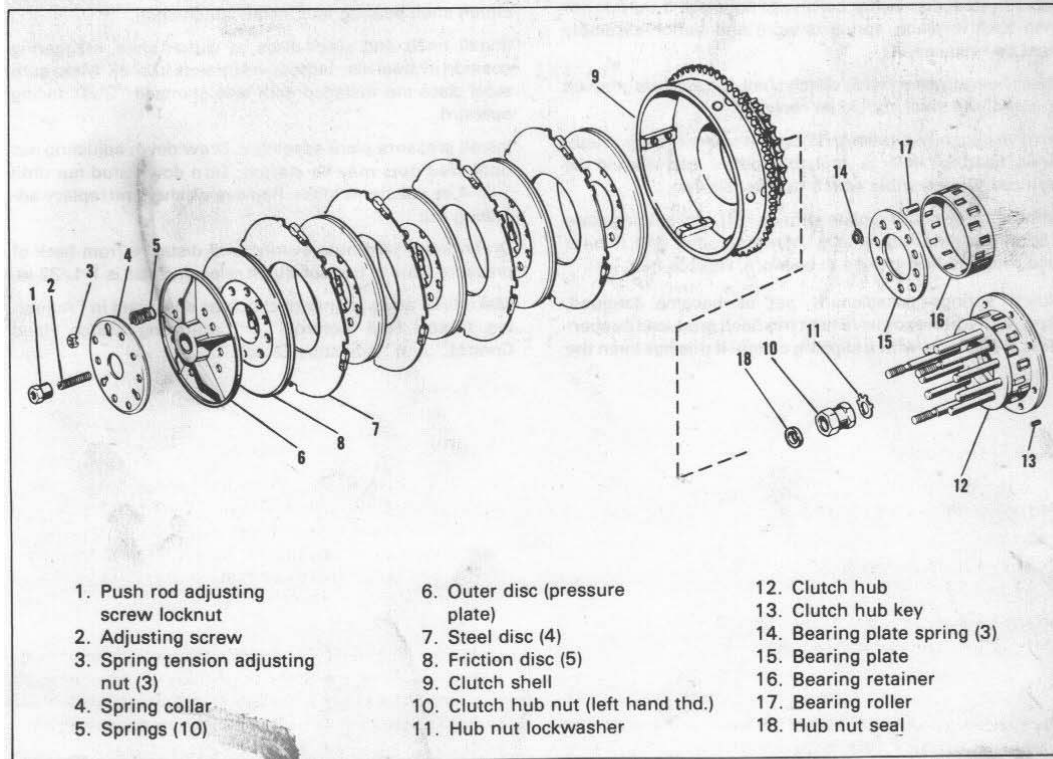

Figure 4-4. Clutch Assembly - Exploded View

CLEANING AND INSPECTION

Wash all parts except friction discs in cleaning solvent and blow dry with compressed air.

Examine friction discs for:

1. A glazed surface which may be recognized by a smooth, shiny and sometimes darkened appearance.
2. Worn or grooved surface.
3. Lining worn down to 1/32 in. or less.
4. Oil impregnated linings which will sometimes accompany glazing.
5. Cracked or chipped linings.

Glazed and oil soaked linings may sometimes be reconditioned by soaking in solvents of various types for several hours, blowing dry with compressed air and roughing with medium coarse sandpaper. This procedure may not be successful because oil retained in pores of lining material may come to the surface due to heat developed during normal use. Grooved linings and excessively worn linings must be replaced. Chipped or cracked linings must also be replaced. Badly glazed and burned linings are probably beyond reconditioning and should be replaced.

Steel discs that are grooved or warped should be replaced. Depress steel disc buffer balls with fingertip. If they do not snap back in place, spring is worn and buffer assembly must be replaced.

Check bearing race inside clutch shell. If it appears grooved or pitted, the shell should be replaced.

Revolve clutch hub roller bearing. If it sticks or feels rough, inner bearing race is probably pitted and should be replaced. Disassemble clutch hub as follows:

Remove three bearing plate springs (14), slip bearing plate (15) off hub pins and remove bearing retainer (16). If inner race thus exposed proves to be worn, replace hub.

Clutch springs occasionally set or become fatigued, especially when excessive heat has been produced by operating motorcycle with a slipping clutch. If this has been the

case, or if clutch discs are in good condition but it was not possible to obtain a suitable clutch adjustment, check clutch spring free length. Also check spring compression using the Valve Spring Tester, Part No. 96797-47. Spring free length should be 1-45/64 in. and compression test should be from 30 to 38 lbs. at 1-1/4 in. Replace springs not meeting compression specifications and those with a free length below specified figure, compression testing to near low tolerance range figure.

Lip type seal (18) should be inspected and replaced if worn or damaged.

ASSEMBLING CLUTCH (Figure 4-4)

Assemble clutch in approximate order of disassembly.

If parts 1, 2, 4, 5 and 6, have been disassembled, preassemble them on clutch hub as follows: Place clutch releasing disc (6) on hub. Position springs (5) on pins and studs. Place spring collar (4) over springs. Note that stud holes are arranged so it fits in only one position. Turn adjusting screw locknut on adjusting screw until head is flush, then turn into pressure plate with 1-3/4 in. washer under nut. Remove this assembly from hub.

Place key in slot in mainshaft. Slip clutch hub onto shaft. Install new oil seal in clutch hub nut. Position lockwasher followed by hub nut. Tighten nut to 50 to 60 ft-lbs torque. Bend over the ear on washer matching hub nut flat. Grease clutch shell bearing and install clutch shell.

Install lined and steel discs in clutch shell, staggering position of steel disc buffers in key slots in shell. Make sure steel discs are installed with side stamped "OUT" facing outward.

Install pressure plate assembly. Draw down adjusting nut until stud nuts may be started. Turn down stud nut until 1-3/4 in. washer is loose. Remove washer and replace adjusting nut.

Draw down stud nuts evenly until distance from back of pressure plate to front of clutch releasing disc is 1-1/32 in.

Make final adjustments to clutch as described in "Adjusting Clutch Foot Control," or "Adjusting Clutch Hand Control," and "Adjusting Clutch."

ELECTRIC STARTER

GENERAL

The Bendix type drive shaft and gear assembly, located in starter housing between starting motor (Figure 4-5) and clutch ring gear, provides automatic means of engaging the starter shaft drive pinion with the ring gear on the clutch sprocket for cranking the engine and for disengaging the drive pinion from the ring gear after the engine starts.

When the starter motor is not operating, the drive shaft worm pinion is disengaged from the ring gear.

When the starter switch button closes starting circuit, the solenoid armature shaft (1) pulls shifter lever (2). Fingers on lever engage groove in shifting collar (3) which forces pinion gear (4) into engagement with clutch ring gear (5). At the same time, solenoid also closes starter motor circuit thus turning the ring gear and cranking the engine. After the engine starts and switch button is released spring return on solenoid shaft returns lever so that pinion gear disengages from ring gear and starter motor shuts off. There are matching spiral threads on starter shaft (6) and pinion gear (4) so pinion will shift if mating teeth do not line up for going into mesh. If starter button is not released after engine starts, pinion gear will turn freely by means of over-running clutch (7) to prevent damage to starter.

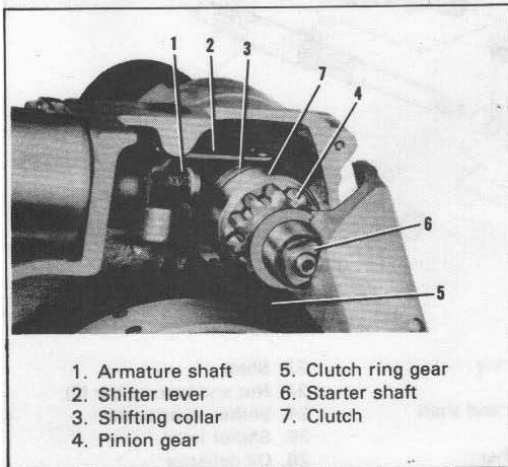

Figure 4-5. Starter Drive

DISASSEMBLING STARTER AND SOLENOID (Figure 4-6)

Remove solenoid as follows:

Disconnect battery ground wire from battery terminal post. Remove cover (1) and disconnect wires from starter solenoid terminals held by nuts and lockwashers (2) and (3).

Remove chain housing cover.

WARNING — Whenever primary chain cover is removed, first disconnect battery cable to prevent accidental starter operation and possible injury.

Depress retainer cap (4), remove pin (5) from hole in plunger (11) shaft. Remove spring (6).

Remove solenoid attaching bolts and lockwasher (7) and spacer bar (8). Remove solenoid (13) with boot (9), gasket (10), plunger (11), and plunger spring (12).

Rotate starter shifter lever (25) end forward and disengage lever fingers from pinion gear shifting collar (20). Pull pinion gear and shaft assembly (14) from housing. Note drive gear (28) will remain in drive shaft housing (29).

To disassemble pinion gear and shaft assembly (14), remove thrust washer (15). Place nut (16) between copper jaws in a vise and unscrew from shaft which has a left hand thread. Remove pinion gear assembly (17). Remove lock ring (18) to separate gear (19), shifter collar (20), and spacer (21) from shaft (22).

To remove starter shifter lever (25), it is necessary to either remove inner chain housing (see "Stripping Motorcycle for Transmission Repair") or remove oil tank.

Remove screw (24) and lever (25) from chain housing.

Remove starter shaft housing from chain housing studs as follows:

Remove starter motor and housing as an assembly by removing nuts and lockwashers (23) from chain housing studs. See "Starter Motor," Section 5.

Remove oil deflector (26) and gear (28) from starter shaft housing (29). Needle bearings (30) and (31) are pressed into housings at shaft ends.

To service starter motor see Section 5.

ASSEMBLING STARTER AND SOLENOID (Figure 4-6)

Assembly is essentially the reverse of disassembly except as follows:

Clean needle bearings (30 and 31) and repack with grease. If replaced, needle bearing (31) should be pressed in flush with outside of housing. Pinion (19), spacer (21) and shaft (22) should be assembled with no lubrication on worm threads.

Shaft nut (16) should be secured to shaft with Harley-Davidson "Stud and Bearing Mount," Part No. 99626-77 after cleaning parts with "Safety Solvent."

Connect battery cable to longest solenoid terminal stud.

CAUTION — If cables are reversed, the solenoid will remain in battery circuit.

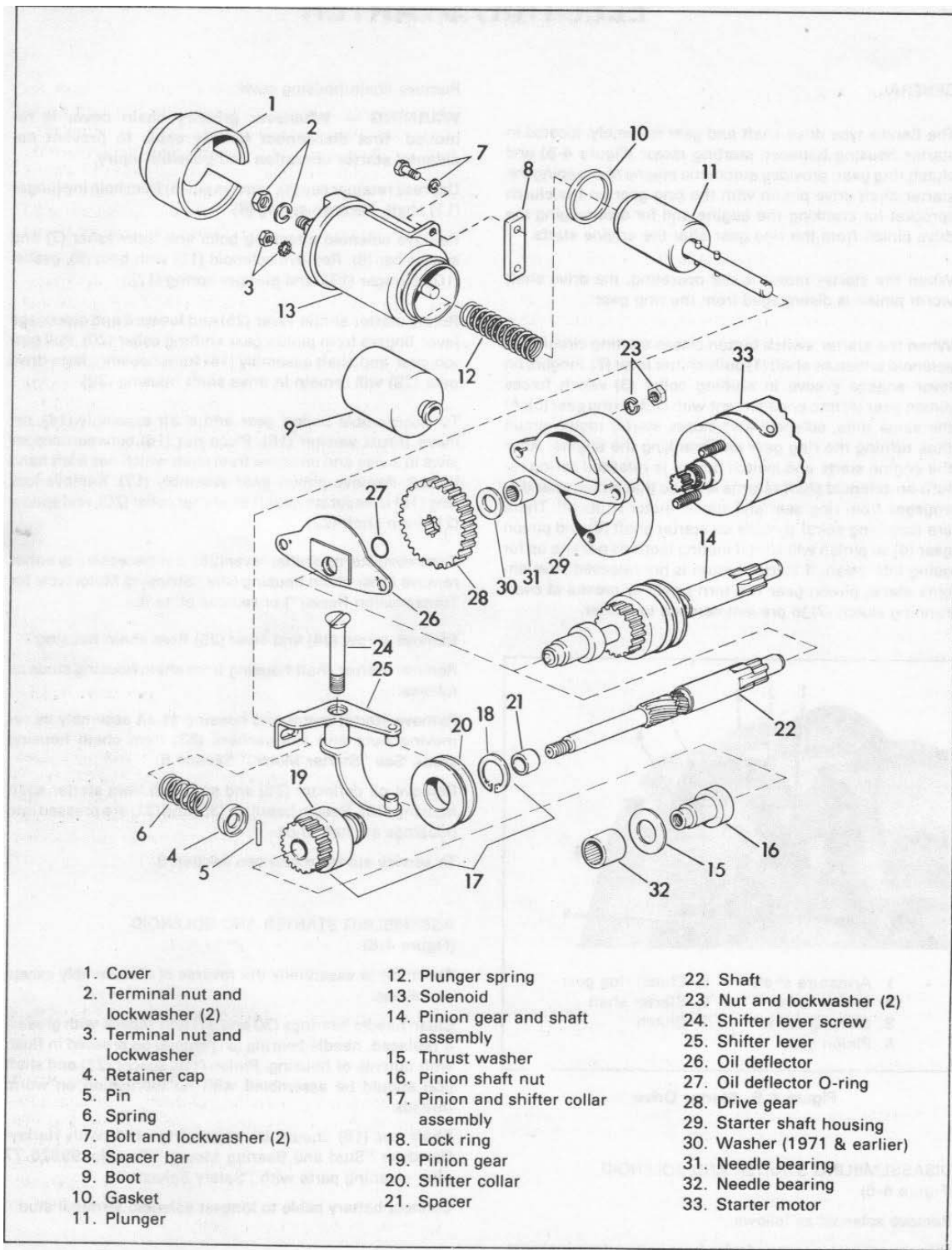

Figure 4-6. Starter Shaft, Housing and Solenoid - Exploded View

KICK STARTER

DISASSEMBLING KICK STARTER (Figure 4-6A)

Place oil drain pan under transmission. Remove starter cover nuts (1) and plain washers (2). Loosen clutch adjusting screw (2, Figure 4-4). If transmission is in chassis, remove clutch lever rod from left end of clutch release lever. Remove exhaust pipe and other components mounted on transmission cover studs. Cover assembly with clutch release lever, assembly is then free to be pulled off mounting studs. Clutch push rod assembly (3) will come off with cover. If starter cover binds, push rod is binding on starter clutch. Pry push rod off starter clutch. Do not pry cover for it will damage bearing. With starter cover removed, push rod (4) is free to be pulled out of mainshaft.

Clamp crankshaft (8) in vise, bend ear of lockwasher (6) away from flat of starter crank nut (5) and remove nut and lockwasher (6). Remove starter gear (7) using the Harley-Davidson All Purpose Claw Puller, Part No. 95635-46. If puller is not available, remove starter crank from vise, and drive starter crank out of starter gear with rawhide mallet. Be sure to hold starter crank and cover from swinging when shaft is free from gear.

With starter gear removed, crankshaft (8) can be pulled out of cover. Thrust washer (9) is installed between starter crank spring (10) and cover (11) with chamfered side of washer facing spring.

Remove nut (12) and lockwasher (13), and pull release lever (14) from end of clutch release lever shaft (15) using All Purpose Claw Puller.

Remove cotter pin (16) and plain washer (17) from lower end of release lever shaft, which can then be pulled out of cover, freeing release finger (18) and thrust washer (19).

Wash all parts in a grease solvent and blow dry.

Insert starter crankshaft in starter cover and check play. If play is appreciable, press out bushings (20) and install new parts. If transmission was leaking oil out starter crank, install new oil seal (21). Bushings are pressed in with outside ends just flush with bushing boss and outer surface of cover.

Bushings (22 and 23) rarely need replacement. However, check fit of release lever shaft and press out old bushings and install replacement parts if shake is considerable.

Check clutch push rod bearing for wear. Replace unit that grinds, feels rough or loose when rotated.

Check starter crank gear cam plate and gear pin to be sure they are in good condition, especially if starter crank bushings were replaced.

ASSEMBLING STARTER (Figure 4-6A)

Install release lever shaft (15) and release finger (18) in cover with thrust washer (19) located between finger and bushing (23), and plain washer (17) and cotter pin (16) on end of shaft.

Install starter crank spring (10) and thrust washer (9) on starter crankshaft (8) with chamfer side facing spring. Apply a film of light grease on oil seal (21) and starter crankshaft before installing. Install starter crank gear. When viewing end of gear, notch on crankshaft (8) should be in 12 o'clock position and dowel pin on gear should be in 7 o'clock position. Install lockwasher (6) and nut (5) and tighten nut to 50 to 60 ft-lbs torque. Bend tab on washer up against flat on nut.

Before starter cover is installed, push rod assembly (3) is inserted into cover. Insert small diameter end of push rod into mainshaft. With oil slinger (3A) in cover and using push rod as a guide, move cover assembly into place. Dowel pin on starter gear must clear front of starter crank stop (33). Tighten all cover nuts (1) to 13 to 16 ft-lbs torque. Install starter crank (8A) and tighten crank bolt (8B) to 25 to 30 ft-lbs torque. Wind spring by turning it with a pliers clockwise and hooking end onto starter crank stud (32).

Refill unit with 1-1/2 pints of same grade of oil used in engine.

Adjust clutch.

Adjust rear brake pedal.

DISASSEMBLING STARTER CLUTCH (Figure 4-6A)

Remove starter cover assembly as described in "Disassembling Starter," and proceed as follows:

Bend ear of lockwasher away from flat of starter clutch nut (25) and remove nut and washer (26). Pull starter clutch (27) from mainshaft taper with Starter Clutch Puller, Part No. 95650-42. With starter clutch removed, starter clutch keys (28), starter mainshaft gear (29) and starter clutch spring (30) are free to be removed from mainshaft.

CLEANING, INSPECTION AND REPAIR (Figure 4-6A)

Wash all parts except gasket (24) in grease solvent and blow dry with compressed air.

Examine teeth on starter clutch and starter gear (29), ratchet teeth on mainshaft gear and starter clutch. Teeth should be sharp edged. If teeth are rounded or mushroomed and rider has experienced ratchet slip, replace worn parts. If starter clutch nut has previously been drawn down too tight, starter clutch may be cracked. If cracked, it is usually difficult to get the starter clutch out of clutch release bearing when disassembling starter cover.

Position mainshaft gear (29) on shaft and check play. If obviously loose, replace bushing (31).

ASSEMBLING STARTER CLUTCH (Figure 4-6A)

Coat gasket (24) with gasket sealer and position on gear box. Lubricate mainshaft with engine oil and slip spring (30) and mainshaft gear over shaft. Bushing should be loose enough on mainshaft to allow gear to slide under force of compressed starter clutch spring. If necessary, line ream bushing to achieve free fit.

Position starter clutch, drive in starter clutch keys and assemble remainder of parts in reverse order of disassembly.

Tighten nut (25) to 50 to 60 ft-lbs torque.

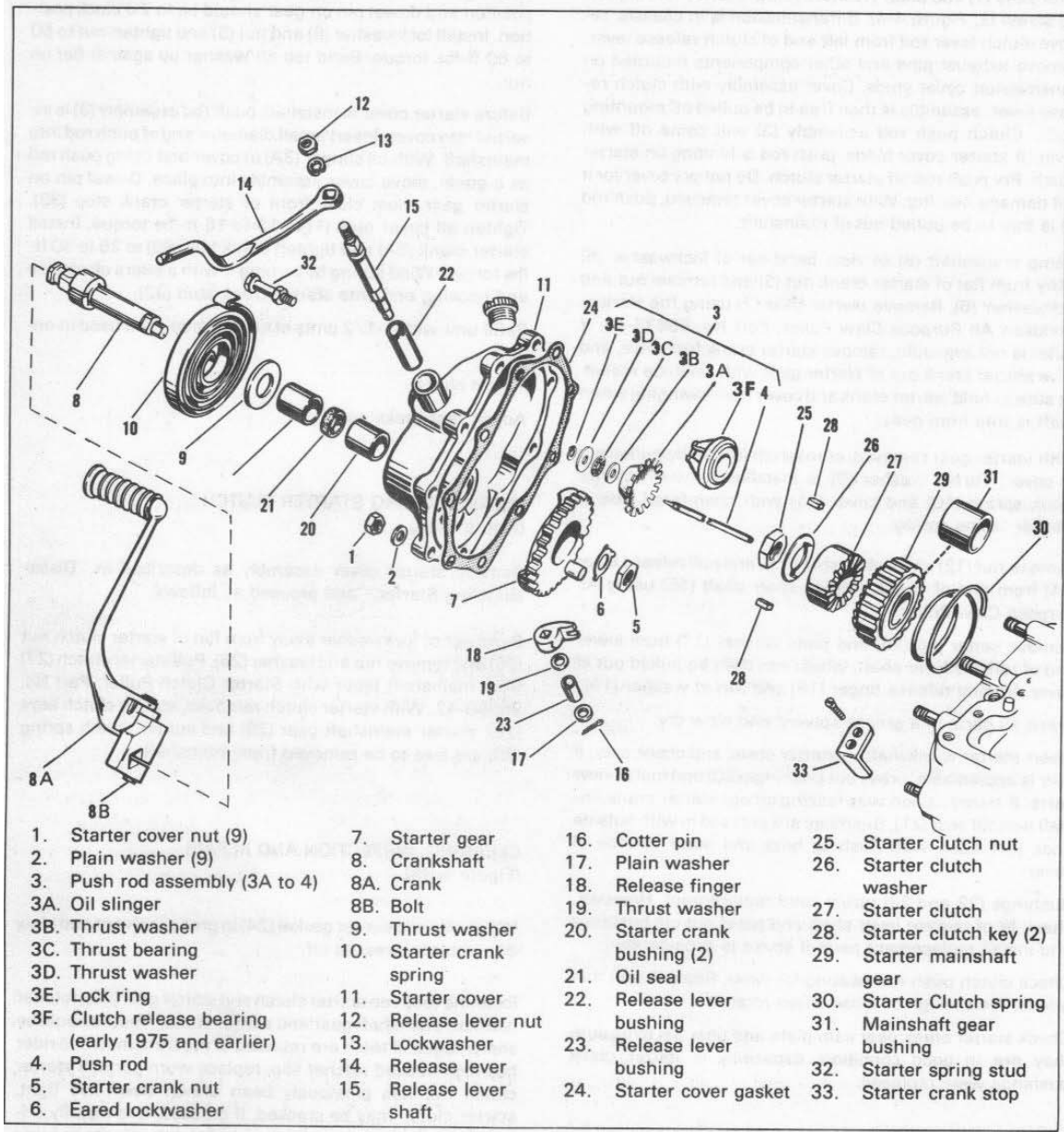

Figure 4-6A. Kick Starter and Clutch Release Assembly - Exploded View

GEAR BOX

SHIFTING LINKAGE

ADJUSTING HAND SHIFT

The hand shift normally requires adjustment only to compensate for wear or when transmission has been moved. Only the shifter rod needs adjustment to maintain correct hand shift lever position.

To adjust hand shift move the shifting lever to third position on four-speed transmissions and to second position on three-speed transmissions.

Disconnect shifter rod from shifter lever; with slight backward and forward movement carefully "feel" the transmission lever into exact position where the shifter spring plunger (inside transmission) seats fully in its retaining notch.

By turning the clevis in or out, carefully refit the shifter rod to the shifting lever without disturbing the shifting lever's exact positioning.

ADJUSTING FOOT SHIFT

The foot shift linkage normally requires adjustment only to compensate for wear or when transmission has been moved. Only the shifter rod needs adjustment to maintain correct foot lever pedal position and prevent interference with the crankcase.

On FL models, mark on end of foot shifter lever shaft should be lined up with slot in foot lever and clamped. No alignment mark is provided on FX model.

On all but FX models, length of rod is adjusted by removing shifter rod end bolt, loosening shifter rod end locknut, and turning rod end farther on or off rod. On FX models, remove retainer clip and adjust the threaded ends on rod. Adjustment is important, as any interference will prevent full movement of foot lever and full engagement of shifting parts inside transmission. Securely tighten locknuts after adjustment is made.

ADJUSTING FOOT SHIFTER COVER

When it is impossible to shift foot shifting mechanism into all gears, adjust as follows:

Disassemble shifter cover parts 1 through 12 as described in "Disassembling Shifter Cover (Foot Shift)," see Figure 4-11. Time shifter notches as illustrated in Figure 4-13. Loosen screw (14, Figure 4-11) and rotate adapter plate (16) until timing notch (Figure 4-13) in adapter plate, located at bottom of shifter gear hole, lines up with notch between two shifter gear teeth. Make alignment exact, then tighten adapter plate bracket screw to lock in position. This adjustment can be made with shifter in any gear (not neutral).

Assemble shifter cover in reverse order of disassembly.

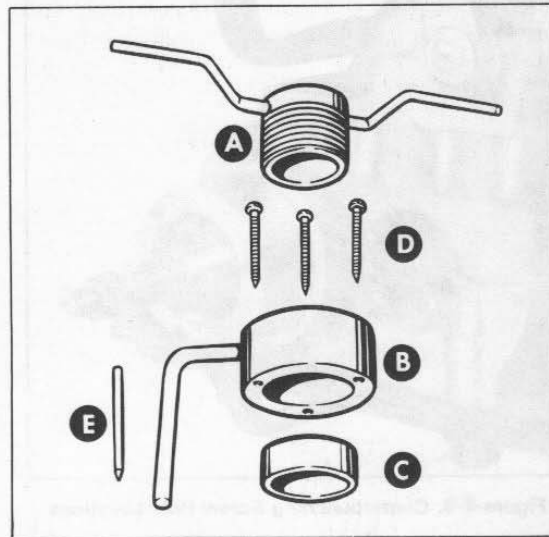

Figure 4-7. Main Drive Gear Oil Seal Tool

MAIN DRIVE GEAR OIL SEAL

GENERAL

Main Drive Gear Oil Seal Tool, Part No. 95660-42, (Figure 4-7) enables removing worn or damaged oil seal and installing new seal without removing or disassembling transmission. It may be used on transmission removed from chassis as well. To use, transmission must be assembled with the exception of clutch and countershaft sprocket.

REMOVING OIL SEAL

Shift transmission into low gear and lock rear wheel brake to prevent parts from turning while disassembling.

Remove outer front chain guard, engine sprocket, front chain, clutch assembly, inner chain guard, transmission sprocket and rear chain.

Place sleeve (C, Figure 4-7) on end of main drive gear. Slide body (B) over sleeve with body stop rod downward. Turn body clockwise until stop bears against transmission case or mounting plate. Hold body in this position and insert center punch (E) through each of the three holes in body and center punch oil seal as shown in Figure 4-8.

Remove body and drill a 3/32 in. hole through metal face of oil seal at each punch mark. Replace body and insert the three self-tapping screws (D) through body and into oil seal. Tighten screws until body is against oil seal.

Turn actuating screw (A) into body and continue turning as shown in Figure 4-10 until oil seal is free. Discard oil seal and oil seal cork washer found behind seal.

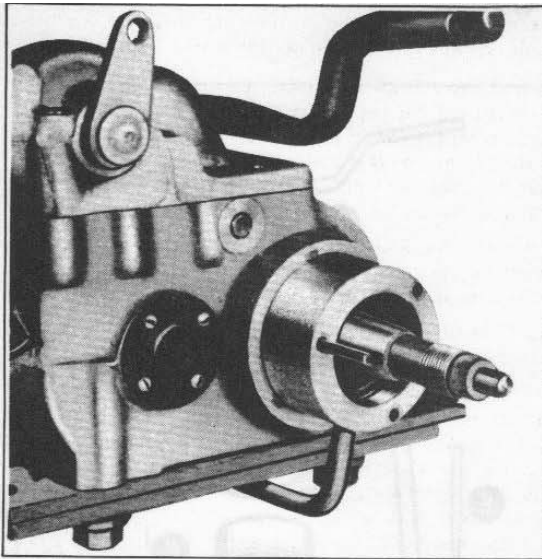

Figure 4-8. Centerpunching Screw Hole Locations

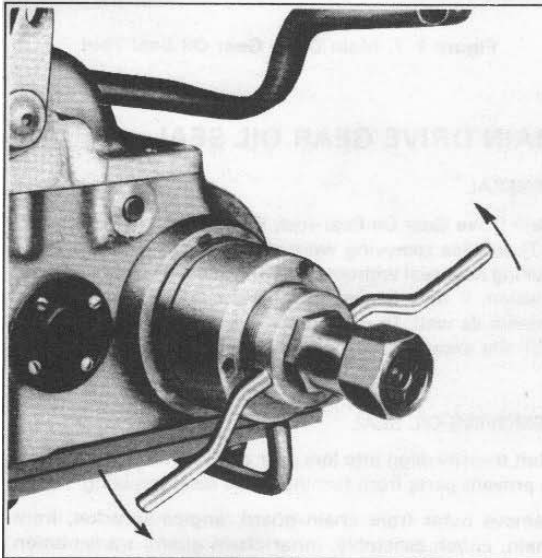

Figure 4-9. Installing Oil Seal

INSTALLING OIL SEAL

Remove burrs with scraper from outer edge of oil seal recess in transmission where metal was staked to secure seal. Position new cork gasket.

Apply a light coat of Harley-Davidson "Gasket Eliminator Sealant," Part No. 99633-77 to the outside diameter of the new seal. Coat lip of oil seal with oil or grease to prevent damage to new seal.

Insert sleeve (C, Figure 4-7) into oil seal. Place sleeve and seal on main drive gear with lip side of seal toward transmission case. Turn seal so it will not stake at same points old seal was staked.

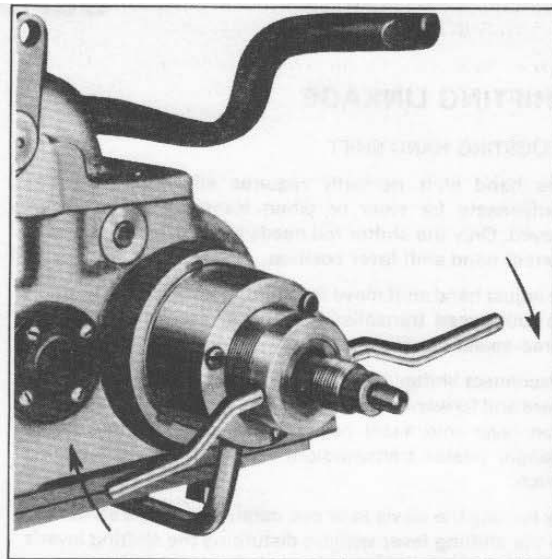

Figure 4-10. Pulling Oil Seal

Place body on sleeve and turn actuating screw into body as far as it will go without pulling body away from seal. Install mainshaft clutch hub nut and turn it in against actuating screw as shown in Figure 4-9. Back out actuating screw until body has pushed oil seal into place and body is tight against end of gear box.

Take care not to plug the oil hole at the base of recess with sealant.

Remove tool and stake case into notches in seal.

After assembly is complete, check clutch control adjustment.

REPLACING MAINSHAFT BALL BEARING

Transmission mainshaft ball bearing (6, Figure 4-19) may be replaced without removing transmission from motorcycle by using the following procedure: Remove transmission side cover (36, Figure 4-18) as described under "Disassembling Kick Starter." Remove 1 through 5 in Figure 4-19. Using a screwdriver, pry out bearing shield. Use hooked end of Puller, Part No. 95650-42, to pull bearing out by engaging hooks of puller to bearing inner race. Use centering button to avoid damaging shaft. Carefully tip in new bearing using care not to damage bearing shield.

SHIFTER COVER

REMOVING SHIFTER COVER

Remove transmission from chassis as described in "Stripping Motorcycle for Transmission Repair."

Remove the 12 screws securing shifter cover to gear box. Shifter cover is registered on two dowel pins. Two of the screws are extra long. Notice that the screw in hole nearest the dowel pin on right side of transmission is vented to relieve gear box heat expansion pressure. This screw must be installed in the same hole when assembling shifter cover or transmission oil may be forced out into clutch.

**DISASSEMBLING SHIFTER COVER
(HAND SHIFT)** (Figure 4-11)

Remove neutral indicator switch (1) and washer (2) from cover. Bend back ear on lockwasher (3) and remove cam follower retainer (4), lockwasher (3), spring (5) and cam follower (6).

Remove camshaft lock screw (7) from left side of shifter cover joint face. Use a suitable drift to tap camshaft (8) from cover. Shifter cam (10) may now be lifted out of cover.

Remove cotter pin (11) from end of shifter shaft. Remove shifter gear (12) and spring (13) from end of shifter shaft. Pull shifter shaft (14) and leather washer (15) out of cover (16).

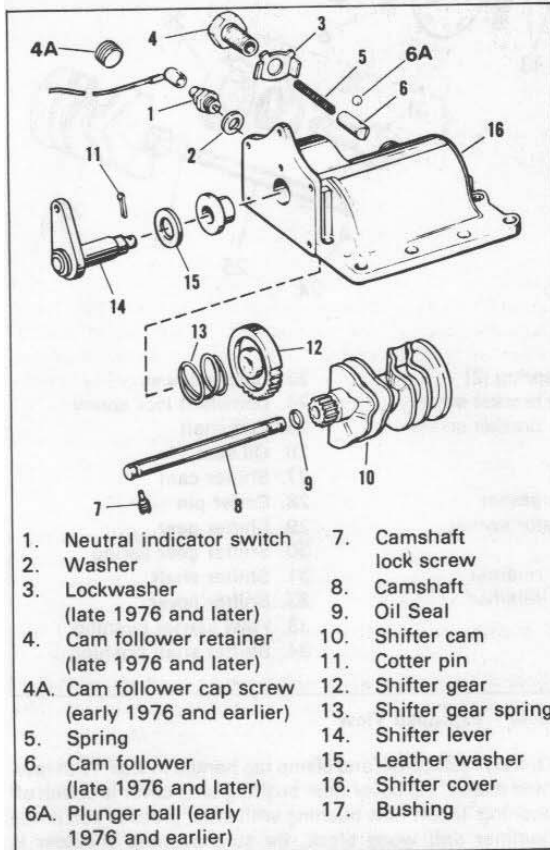

Figure 4-11. Hand Shifter Cover - Exploded View

CLEANING, INSPECTION AND REPAIR
(Figure 4-11)

Clean all parts except camshaft oil seal (9) and leather washer (15) in solvent and blow dry with compressed air.

Inspect shifter lever fit in bushing (17). If there is considerable side play, replace bushing as follows. Thread a 5/8 in. tap into bushing about 1/2 in. deep. Remove tap and heat case around bushing to about .300 degrees F. Replace tap and clamp in vise. Tap cover with rawhide mallet or block of wood and hammer until cover is driven off bushing. Press in new bushing.

Inspect gear teeth on shifter cam and shifter gear. If wear is deep, replace parts. Slightly worn parts may be used safely with no impairment to proper function.

Inspect neutral indicator switch. Depress plunger in base of body. It should spring back without a bind. If neutral indicator light fails to light in neutral position, plunger is sticking. Switch cannot be repaired, it must be replaced. Do not test switch by passing current through it without having a neutral indicator bulb in the circuit series.

Inspect spring and cam follower. If tip of cam follower is rounded, replace it. To function properly, cam follower must have a reasonably sharp tip.

ASSEMBLING SHIFTER COVER (HAND SHIFT)
(Figure 4-11)

It is necessary to time shifter lever gear (12) to gear on shifter cam (10). Install shifter gear spring (13) and shifter gear (12) in cover with spring located over gear hub and timing mark between gear teeth to outside (facing cover bushing). Install shifter cam (10) so notch in gear tooth is aligned with timing mark on shifter gear. Install shifter lever and shaft assembly (14), with square end of shaft in hole in gear with shifting lever pointed toward left, front screw hole in cover, and leather washer (15) between lever and cover bushing.

Insert cotter pin (11) in shaft hole.

Place shifter cam in cover with timing mark on tooth registered with timing mark between teeth on side of shifter lever gear.

Install shifter camshaft (8) and secure with lock screw (7). Be sure oil seal is in place with widest groove in right end of shaft. Shifter cam end play should be 0.0005 in. to 0.0065 in. If greater, install shim washer of desired thickness. If less than desired amount, file boss in case until recommended play has been achieved.

Install cam follower (6), spring (5), lockwasher (3) and cam follower retainer (4). Bend ear of lockwasher against flat on retainer.

DISASSEMBLING SHIFTER COVER (FOOT SHIFT)
(Figure 4-12)

Remove three shifter lever screws (1), and remove lever (2) and dust shield (3). Remove five long shifter cover screws (4) and one short screw (5) by removing nut (6) located on rear of adapter plate (16). The pawl carrier cover (7), gasket (8), and pawl carrier (9) are then free to be removed. The pawls (10 and 11), pawl spring (12), and pawl carrier springs (13) are under compression and will pop out when pawl carrier is removed. Remove adapter plate bracket screw (14) and washer (15) to free adapter plate (16) and gasket (17).

Remove neutral indicator switch (18) and washer (19) from cover. Bend back ear on cam follower retainer washer (21) and remove retainer (20), washer (21), spring (22) and cam follower (23).

Remove shaft lock screw (24) from left side of shifter cover joint face. Using a suitable drift, tap camshaft (25) from cover. Tap toward O-ring end of shaft. Shifter cam (27) may be lifted out of cover.

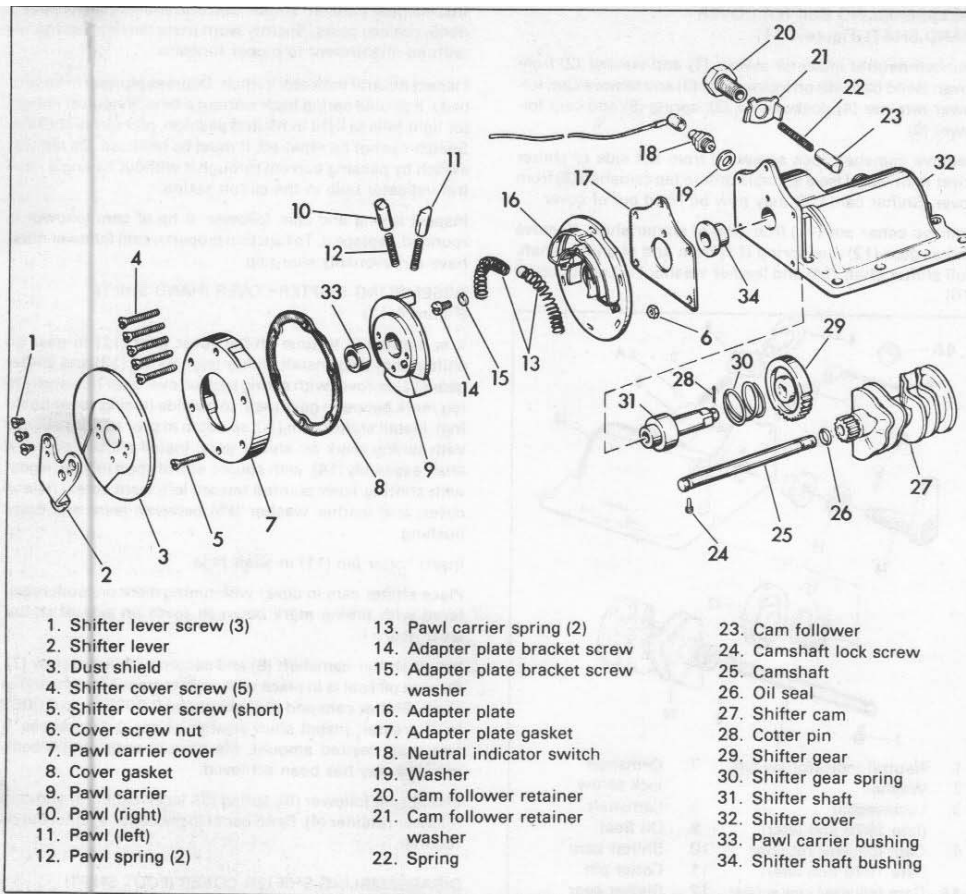

Figure 4-12. Foot Shifter Cover - Exploded View

Remove cotter pin (28) from end of shifter shaft. Remove shifter gear (28) and spring (30) from shaft and pull shaft (31) out of cover (32).

CLEANING, INSPECTION AND REPAIR
(Figure 4-12)

Clean all parts except gaskets (8 and 17), and neutral indicator switch (18) in grease solvent. Clean switch with "Gunk" or solvent.

Inspect fit of shaft (31) in bushings (33 and 34). If there is considerable side play, replace bushings. Pawl carrier bushing (33) may be pressed out of carrier on arbor press. Shifter shaft bushing (34) is removed as follows: Thread 5/8 in. tap into bushing about 1/2 in. deep. Remove tap and heat shifter cover around bushing to about 300 degrees.

Quickly replace tap and clamp tap handle in vise. With rawhide mallet, tap cover near bushing until cover is driven off bushing. Insert new bushing with arbor press or soft metal hammer and wood block. Be sure bushing shoulder is seated against cover.

Inspect teeth on shifter gear and cam. Replace badly worn parts.

Inspect neutral indicator switch. Depress plunger in base of body. It should spring back without a bind. If panel light fails to light in neutral position, plunger is sticking. Switch cannot be repaired, it must be replaced. Do not test switch by passing current through it without having a neutral indicator panel light bulb in the circuit in series.

Inspect all springs. Inspect tips of cam follower (23) and shift pawls (10 and 11). If tips are rounded and worn, replace parts. To function properly these parts must have reasonably sharp tips.

Inspect all parts generally for cracks, bent parts and any wear that would impair intended functions. If hole in pawl carrier is elongated, bushing (33) must be replaced or mechanism will not shift properly.

ASSEMBLING SHIFTER COVER (FOOT SHIFT) (Figure 4-12)

It is necessary to time the shifter shaft (31) to the shifter gear (29), and the shifter gear to the cam gear on the shifter cam (27). If this is not done correctly, it will be impossible to shift into all gears.

Note position of the timing mark (Figure 4-13). This is the proper timing alignment.

Refer to Figure 4-12. Position shifter gear (29) and spring (30) in case, so side of gear with timing mark is toward case. Insert shifter shaft (31) so parts are timed as shown in Figure 4-13 and tap parts together. Insert cotter pin (28).

Install shifter cam (27) in cover so ground timing mark on top of a tooth or short tooth registers with timing mark on shifter gear. Slip oil seal (26) on the inner of two grooves on end of camshaft (25) and insert in cover, passing it through shifter cam. Secure shaft with lock screw (24).

Install cam follower (23), spring (22), retaining washer (21) and retainer (20). Install neutral indicator switch (18), washer (19) and check to make sure button on shifter gear contacts plunger in base of switch.

Position cover (32) in vise with shifter mechanism end upward. Place gasket (17) and adapter plate (16) over cover. Insert adapter plate bracket screw (14) and washer (15) in hole directly above end of shifter gear but do not tighten. Shift cam to any position but neutral. Rock cam back and forth to make sure spring loaded cam follower is seating exactly in one of the indexing notches, or "V's," that determine cam position for one of the four gears.

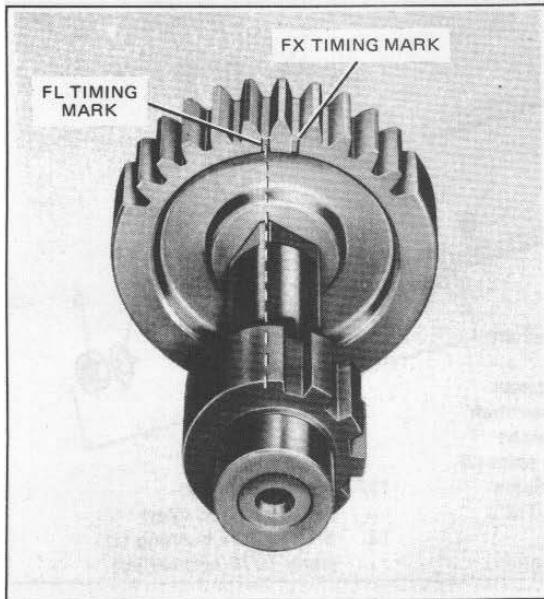

Figure 4-13. FLH Timing Shifter Gear

Rotate adapter plate until timing notch (Figure 4-14) in adapter plate, located at bottom of shifter gear hole, lines up with notch between two shifter gear teeth. Make alignment exact, then tighten adapter plate bracket screw (14).

Rotate shifter drum making sure that at each index point, timing notch on adapter plate aligns exactly between two shifter teeth. If alignment is correct, tighten screw (14) to 6-9 ft-lbs torque. If alignment is not correct, drum is not properly timed to shifter gear. Disassemble and align marks as explained above.

Apply "Grease-All" grease to curved springs (13) and insert them in slots on adapter plate. Grease ratchet end of shifter shaft. Lubricate pawls (10 and 11) with light oil after checking to see if they are free in holes in pawl carrier (9). Install pawl springs (12) and pawls in pawl carrier so notches in ends of pawls face inward or toward each other.

Install pawl carrier with pawls over end of shifter shaft with lug on pawl carrier inserted between ends of pawl carrier springs.

Lubricate back of pawl carrier with "Grease-All" grease and install cover gasket (8) and cover (7) so notches at top line up with corresponding notch on adapter plate. Apply Harley-Davidson "Stud and Bearing Mount," Part No. 99626-77, to threads of shorter screw (5) and insert through bottom hole. Secure with nut (6) on back of adapter plate. Apply "Stud and Bearing Mount" to threads of five long screws (4) and tighten all screws.

Position cover dust shield (3) over dowel pins on pawl carrier. Position shifter shaft lever (2) over dowel pins and secure with three shifter shaft lever screws (1). Also treat the threads of these screws with "Stud and Bearing Mount" before inserting.

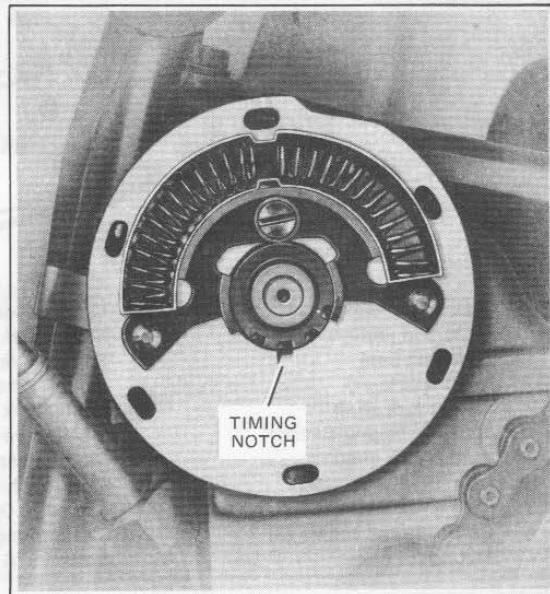

Figure 4-14. Timing Shifter Notches

REPLACING SHIFTER COVER

Before replacing shifter cover, check shifter fork spacing described under "Assembling Shifter Forks."

Coat shifter cover gasket with gasket sealer and position on gear box. Install assembled shifter cover over gear box opening and secure with twelve screws. Note that two screws are longer. They are inserted in holes adjacent to bulge in cover over shifter gear. The short cover screw with vent hole is inserted in hole nearest locating dowel pin on right side of gear case. Use "Stud and Bearing Mount" on all screw threads except the single vent screw.

SHIFTER FORKS

REMOVING SHIFTER FORKS (Figure 4-15)

Remove shifter cover and transmission side cover as described in "Removing Shifter Cover."

On early 1976 and earlier models, shifter fork shaft (2) is held in position by lock screw (1) which may be found in gear box cover joint surface in line with right end of shaft. On late 1976 and later models, shaft is held in place with a lock ring (1A). With lock screw or ring (1 or 1A) removed, shaft may be driven out by means of a drift inserted in hole in starter cover joint face of gear box. Notice that a rubber oil seal (3) is assembled in groove on left end of shifter fork shaft.

Shifter fork assemblies (A and B) are not interchangeable. Note exactly the arrangement of parts and components in each. Keep parts separate to avoid needless adjusting when reassembling. If inspection shows fork assemblies are not damaged, worn or bent, it may not be necessary to disassemble them unless shifter clutches are replaced. Adjustments are described in "Assembling Shifter Forks."

DISASSEMBLING SHIFTER FORKS (Figure 4-15)

If it is necessary to disassemble shifter forks, lift off shifter finger rollers (4), pry back ear on lockwasher (6) and turn off nut (5). Remove washer (6), shift forks (7, 8 or 8A), 5/64 in thick standard spacing shim (9), more .007 in. or .015 in spacing shims (10), Shifting fingers (11) and shifter fork bushings (12).

CLEANING, INSPECTION AND REPAIR

Clean all parts in cleaning solvent and blow dry with compressed air.

If shifter forks are bent or worn, replace them. Straightened forks are weak. They may break and cause extensive damage to gear box parts.

Check fit of shifter fork bushings on shaft. If bushings are loose enough to give fork action lash, replace them. Check replacement part fit on shaft.

Lap out bushings or shifting fingers if they bind. Shifting will be difficult unless they work freely on shaft.

ASSEMBLING SHIFTER FORKS

Assemble shifter forks in reverse of disassembly order making sure parts are not transposed. Tighten nuts (5) to 25 ft-lbs torque.

Place shifter forks in gear box and install shifter fork shaft. Fork with narrow opening is for high gear shifter clutch.

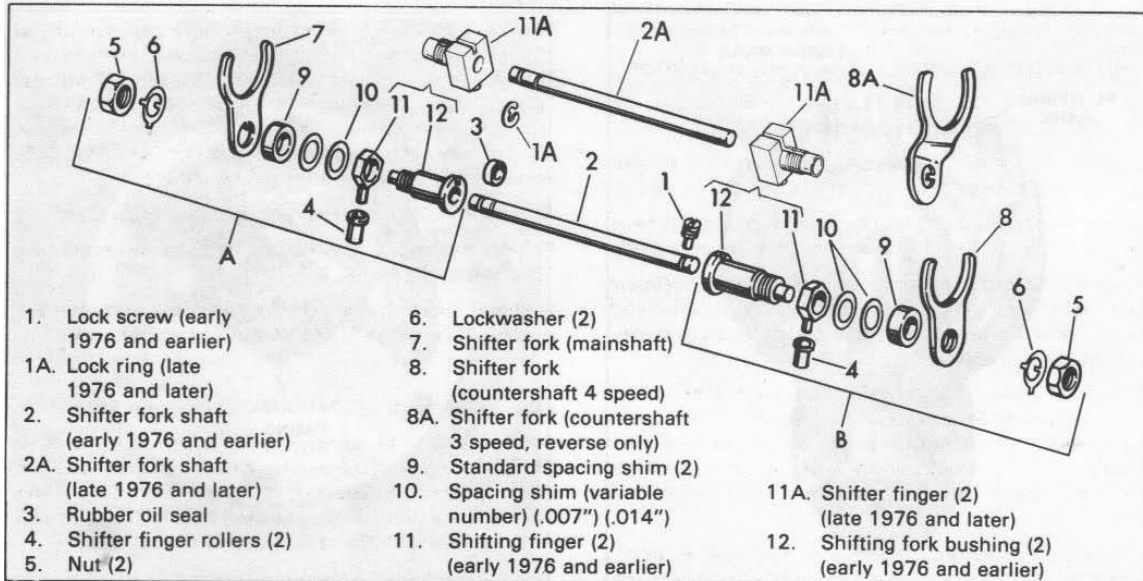

Figure 4-15. Shifter Fork - Exploded View

Check adjustment of shifter forks with Fork Shifter Gauge, Part No. 96384-39, by placing shifter gauge on shifter cover as shown in Figure 4-16. With the 3/8 in. gauge rod furnished, set tool gauge blocks in exact alignment with straight sections of cam slots in shifter cam. Lock gauge blocks in place with thumb screws. Rotate shifter cam and repeat for other cam slot.

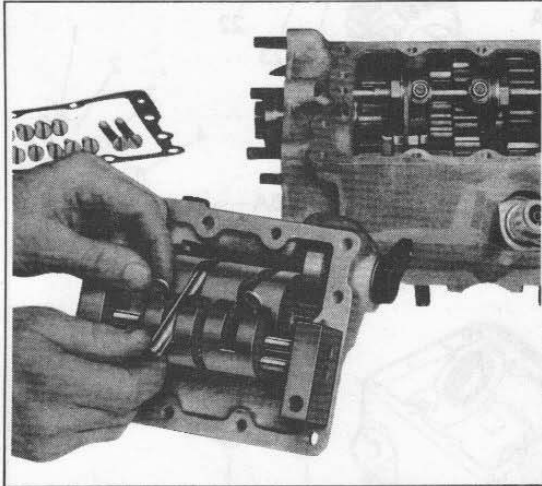

Figure 4-16. Adjusting Shifter Gauge

Remove tool from cover, turn it over, and place it on transmission case with shifter fingers engaged in slots on gauge blocks as shown in Figure 4-17. Be sure shifter finger rollers are in place on shifter fingers.

With thickness gauges, check clearance on both sides of shifting clutches. All shifting clutches must be centered.

Clearances between shifter clutch and gear are as follows:

Low and second gear: When centered between gears to have .080-.090 in. clearance on both sides.

Third and high gear: When centered between gears to have .100-.110 in. clearance on both sides.

Sliding reverse gear: When centered between gears to have approximately .060-.070 in. clearance between gear teeth.

Where shifter clutch engagement is with dogs protruding from face of gear, turn gear so dogs on shifter clutch and dogs on gear are overlapping each other about 1/8 in. before checking clearance.

When clearances are not equal and correct, shifting fork assemblies must be corrected by increasing or decreasing the number of shims between shifter fork and shifter finger. To make this adjustment, remove shifter fork assemblies from transmission. Shims are available .007 in. and .014 in. thick.

After taking out or adding shims, be sure fork assembly locknut is tight. However, excessive tightening may close up hole in bushing so it is no longer a free, sliding fit on shaft.

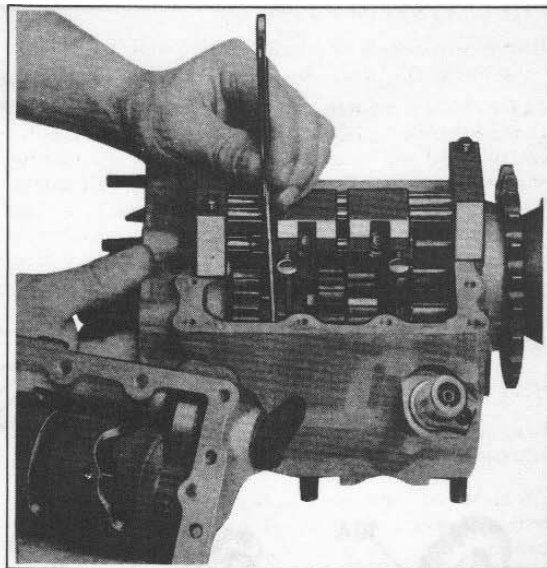

Figure 4-17. Checking Shifter Clutch Clearance

Install shifter shaft lock screw or lock ring.

Assemble shifter cover to gear box as described in "Replacing Shifter Cover."

GEAR BOX (FOUR SPEED)

DISASSEMBLING GEAR BOX

Remove transmission from chassis as described in "Stripping Motorcycle for Transmission Repair."

Remove shifter cover. Slide shifter forks together so that two gears engage, locking transmission. Remove kick starter clutch as described under "Disassembling Kick Starter." If main drive gear is to be removed from transmission, remove rear chain sprocket nut (left hand thread) and sprocket while transmission is locked. Remove shifter forks as described under "Removing Shifter Forks."

Remove clutch as described in "Disassembling Clutch."

Remove starter assembly and starter clutch as described in "Disassembling Starter."

Remove shifter cover and shifting forks as described in "Removing Shifter Cover" and "Removing Shifter Forks."

DISASSEMBLING COUNTERSHAFT (Figure 4-18)

Bend tabs on lockwasher (6) flat. Remove countershaft nut (5). Tap countershaft (8) part way through countershaft gear (25 or 25A) with a suitable drift. Using a short piece of wire shaped like a hook, lift countershaft washer (9) out of case. Push countershaft the rest of the way out of case.

Remove low gear (10), low gear bushing (11), low gear bearing washer (12) and shifter clutch (13) off splined countershaft (8).

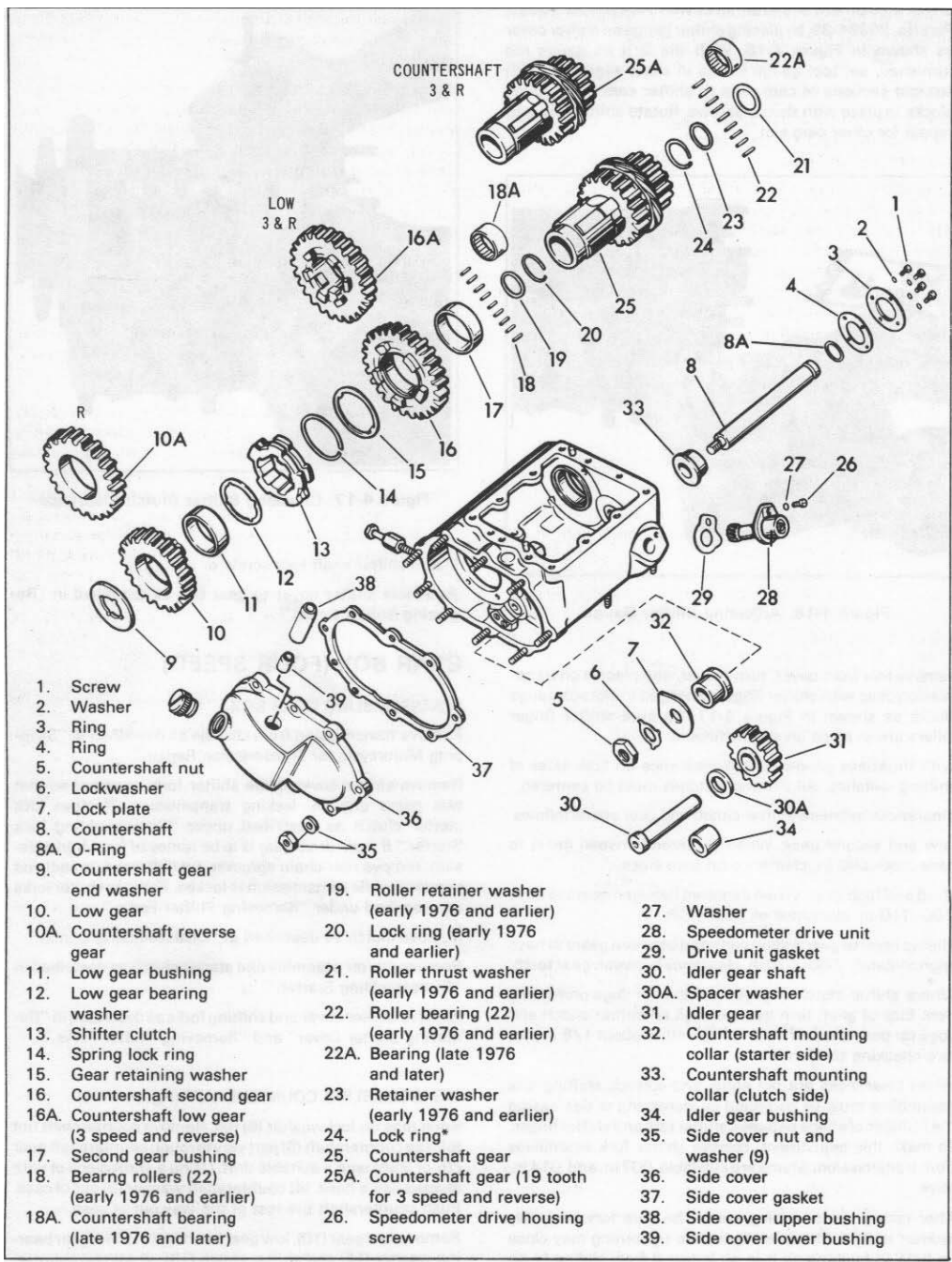

Figure 4-18. Countershaft and Case Assembly - Exploded View

Remove spring lock ring (14), gear retaining washer (15), countershaft second gear (16) and second gear bushing (17).

Remove the bearings (18 or 18A) and lock ring (20).

Remove roller thrust washer (21), bearings (22 or 22A), retaining washer (23) and lock ring (24) from opposite end of countershaft gear (25).

CAUTION — On early 1976 and earlier models, when disassembling countershaft assembly, be sure all rollers (18 or 22) are accounted for and roller set from each end of gear is wrapped separately in paper or cloth. Mark each roller set for end of gear from which it was removed. If any of the rollers are lost or if sets become mixed, both sets will have to be replaced with new parts even though in serviceable condition.

Remove speedometer drive housing screw (26) and washer (27) and lift out speedometer drive unit (28) and gasket (29) from gear case.

DISASSEMBLING MAINSHAFT (Figure 4-19)

Remove the four bearing housing retaining plate screws (1), oil deflector (2) and retaining plate (3).

Drive mainshaft assembly toward right side of case with rawhide mallet or block of wood and hammer until mainshaft third gear (10) contacts boss in bottom of case. With screwdriver or other suitable tool, pry lock ring (12) out of groove in mainshaft and slide it onto mainshaft splines. Drive mainshaft (9) out right side of case, slipping third gear (10), retaining washer (11), spring lock ring (12) and shifter clutch (13) off left end of mainshaft and out through shifter cover opening in case.

Disassemble the mainshaft gear and ball bearing assembly only if inspection shows a need for replacing worn or damaged parts.

Clamp mainshaft in copper-faced vise jaws. Bend ear of lockwasher (5) away from flat of nut (4) and remove nut and washer. Bearing (6) and gear (8) may then be removed with the All Purpose Claw Puller, Part No. 95635-46 or an arbor press. If using claw puller, insert center Adapter, Part No. 95636-46 into end of shaft to prevent damage to shaft. Bearing and gear are removed separately.

DISASSEMBLING MAIN DRIVE GEAR (Figure 4-20)

Position gear box in vise and nail or bolt length of rear chain to bench. Engage chain on sprocket teeth to keep sprocket from turning.

Bend ear of lockwasher away from flat of nut and remove sprocket locknut (1) and washer (2) with special Wrench, Part No. 94660-37. Nut has left hand thread. Remove sprocket (3) from gear. Push main drive gear (4) into case and withdraw it from top. Thrust washer (6) usually comes out with gear. Remove the 44 roller bearings (7) or needle bearings (7A). Be sure all rollers are accounted for and wrap them in paper or cloth. If any of these rollers are lost or if rollers from another bearing become mixed with them, the entire set must be discarded and a new set fitted, even though the old rollers are in serviceable condition.

Remove main drive gear oil seal (8) and main drive gear spacer (10).

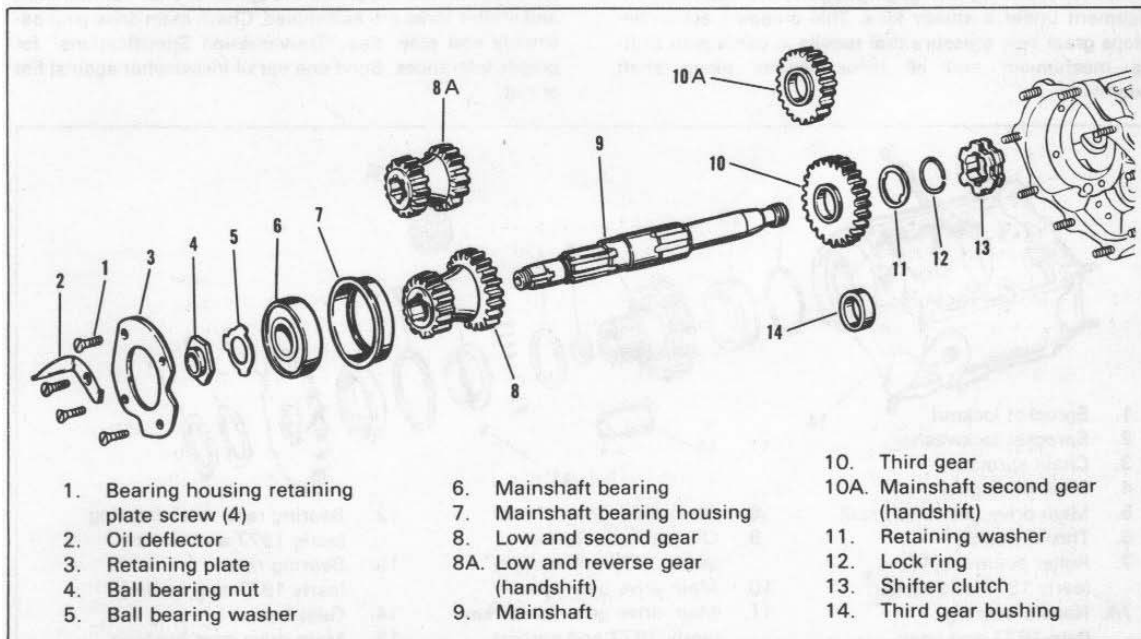

Figure 4-19. Mainshaft Assembly - Exploded View

CLEANING, INSPECTION AND REPAIR

Clean all parts except gaskets (all gaskets should be replaced) with cleaning solvent and blow dry with compressed air.

Inspect all gears. If teeth are pitted, scored, cracked, chipped or if case hardening is worn through, replace with new gears. Replace sprocket if worn.

Inspect all bushings, bearing races and shafts. If bent or worn, install new parts. If mainshaft ball bearing (6, Figure 4-19) is worn to point where play is obviously too great, install new bearing.

To install main drive gear bearing race (13, Figure 4-20), heat case to about 300 degrees and press out old race with arbor press after removing bearing race retaining ring (12). Reheat case and press in new race until flange is seated against case. Install new bearing race retaining ring.

Oil seal (5), cork washer (9) and oil seal (8) should not be reinstalled if they have been removed. An oil leak will probably develop. Use new parts.

Press new mainshaft seal (5) into drive gear recess, use a piece of 1 in. dia. thin wall tubing using mainshaft as a pilot. Before installing, apply a coat of Harley-Davidson "Retaining Compound," Part No. 99628-77 in recess to prevent any oil leakage.

Carefully check shifter clutches (13, Figures 4-18 and 4-19) and engaging dogs on gears. If they are rounded or battered appearing, they must be replaced.

Worn shifter clutch and gear dogs result from shifting abuses or from out-of-adjustment clutch that does not release fully. Damaged engaging dogs try to creep out of engagement under a steady load. This creeping action develops great side pressure that results in damage to shifting mechanism and all thrust points along shaft assemblies.

Check bearings (7 and 7A, Figure 4-20 and 18, 18A, 22 and 22A, Figure 4-18) for proper fit in races according to tolerances shown in "Transmission Specifications." Replacement rollers are available standard, .0004 in. and .0008 in. oversize.

ASSEMBLING MAIN DRIVE GEAR

(Figure 4-20)

Assuming that main drive gear oil seal (8), oil seal cork washer (9) and gear spacer (10) are assembled in case (replacing these parts must be done before gear box is disassembled or after it is repaired and assembled as described in "Installing Oil Seal"), install rollers (7) in bearing outer race (13), holding rollers in place with a light coat of grease, or install needle bearing (7A).

On early 1977 and earlier models, install main drive gear thrust washer (6) on main drive gear. Insert main drive gear (4) into gear box. Be sure rollers stay in place as gear is inserted. Install main drive gear spacer key (11), registering longer section of key in any splineway on main drive gear and shorter section of key in outer edge of main drive gear spacer.

On late 1977 and later models, press needle bearing (7A) into case. Press on lettered side of bearing only and install bearing flush with the case.

Install sprocket (3) with flat side outward. Install lockwasher (2) and sprocket locknut (1). Hold sprocket as outlined in disassembly procedure and tighten nut to 140-150 ft-lbs torque with Wrench, Part No. 94660-37. On 1974 and later FX models, assemble the sprocket after countershaft and shifter forks are assembled. Check main drive gear assembly end play. See "Transmission Specifications" for proper tolerances. Bend one ear of lockwasher against flat of nut.

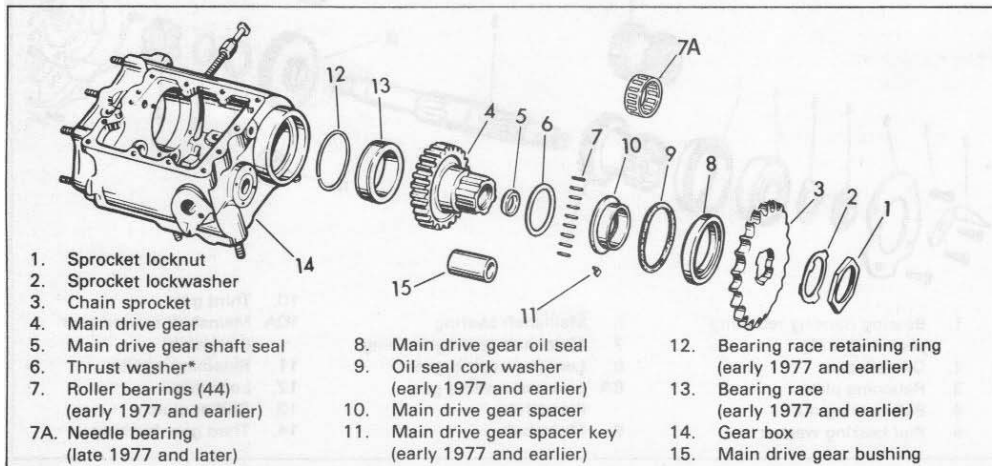

Figure 4-20. Main Drive Gear - Exploded View

ASSEMBLING MAINSHAFT (Figure 4-19)

Assemble parts 4 through 8 to mainshaft before installing mainshaft in gear case. Position gear (8) on shaft splines. Press or fit ball bearing housing (7) over ball bearing (6) and press onto shaft. Assemble lockwasher (5) and nut (4) to shaft and tighten to 50-60 ft-lbs torque. Bend over one ear of lockwasher against flat of nut.

Insert mainshaft assembly into gear box far enough to install gear (10), thrust washer (11), lock ring (12) and shifter clutch (13) over shaft. Always install new lock rings and make sure they are properly seated in lock ring groove. One side of mainshaft shifter clutch is stamped "HIGH." Make sure this side faces main drive gear.

With a suitable tool, work lock ring onto shaft splines. Use tool wedged against shifter clutch to force lock ring into seat in shaft. Use care not to distort lock ring.

With a soft metal hammer or brass drift, tap mainshaft assembly into case until flange on ball bearing housing is shouldered against case. Install retaining plate (3), oil deflector (2) and four screws (1). Tighten screws to 6-9 ft-lbs torque.

If working on three-speed transmission, install reverse idler gear (31, Figure 4-18) and shaft before installing retaining plate.

ASSEMBLING COUNTERSHAFT (Figure 4-18)

Before installing countershaft gear train to shaft and case, it is necessary to check bearing fit and shaft end play.

If countershaft mounting collars (32 and 33) were removed for replacement, press or drive old parts out and new parts in after gear case has been heated to approximately 300 degrees to expand case and facilitate pressing.

On early 1976 and earlier models, install roller sets (18 and 22) in countershaft gear (25), holding them in place with a coat of grease. Be sure lock rings (20 and 24) and bearing retaining washers (19 and 23) are in place before installing bearings. Install bearing thrust washer (20) in its recess in left end of countershaft gear. Install countershaft temporarily to check bearing fit. See "Transmission Specifications" for tolerances.

On late 1976 and later models, install needle bearings (18A and 22A) in countershaft gear. Coat bearings with grease.

Install countershaft gear in case holding end play adjusting washer (9) in place with daub of heavy grease. Install countershaft.

Check end play with feeler gauge between end play adjusting washer and end of countershaft gear. Consult transmission specifications for tolerances. Increase or decrease end play as necessary by fitting end play adjusting washer of required thickness. Washers are available in thicknesses of .074, .078, .082, .085, .090, .095 and .100 in.

When correct gear end play has been established, remove countershaft and gear from case. Set aside adjusting washer until needed for assembly.

Install gear bushing (17), gear (16), thrust washer (15) and gear lock ring (14) on countershaft gear (25).

Install shifter clutch (13), thrust washer (12), gear bushing (11) and gear (10) on countershaft gear. Check to make sure all rollers are in place in gear.

Place end play adjusting washer (9) on end of countershaft gear, holding in position with daub of grease. Position assembly in case and insert countershaft (8) with O-ring (8A) and lock plate (7). Straight edge of lock plate fits against edge of bearing retaining plate (3, Figure 4-4). Install lockwasher (6) and nut (5). Tighten nut to 56-65 ft-lbs torque and bend over one ear of lockwasher against flat of nut.

Install gasket (29), drive unit (28), washer (27) and screw (26).

ASSEMBLING GEAR BOX

Install shifter forks as described under "Assembling Shifter Forks" and check spacing. Slide shifter forks together to lock transmission and install sprocket (if not on), lockwasher and nut. Tighten nut to 140-150 ft-lbs torque and bend tab on lockwasher against flat on nut. Install starter clutch and check shifter spacing. Install side cover and shifter cover. Install all above items as described in pertinent sections.

Assemble transmission to motorcycle and connect controls in reverse order of stripping procedure described in "Stripping Motorcycle for Transmission Repair."

GEAR BOX (THREE SPEED AND REVERSE)

DISASSEMBLING AND ASSEMBLING GEAR BOX

A three forward speed and reverse transmission cannot be installed on a foot shift model motorcycle, and a three-speed transmission cannot be assembled in a four-speed gear case.

The disassembly, repair and assembly procedures for a three-speed and reverse transmission are the same as for a four-speed transmission except for the following differences:

Refer to Figure 4-18. In three-speed and reverse countershaft assembly, omit shifter clutch (13), lock ring (14), thrust washer (15) and gear bushing (17).

Substitute gear 10A for 10, 16A for 16, and 25A for 25.

Refer to Figure 4-19. Substitute 8A for 8 and 10A for 10.

Refer to Figure 4-15. Substitute 8A for 8.

Idler gear shaft (30), spacer washer (30A) and idler gear (31) are removed by threading a 1/4-20 tap or screw into end of shaft, grasp screw head in pliers and pull shaft out of case. It may be necessary to heat the case to facilitate pulling the shaft.

TOOLS



Part No. 94557-55 Compensating Sprocket Shaft Nut Wrench

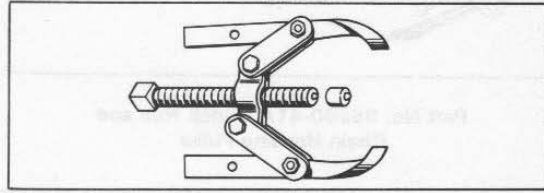

Part No. 95635-46 All Purpose Claw Puller



Part No. 94635-41 Mainshaft Ball Bearing Locknut Wrench

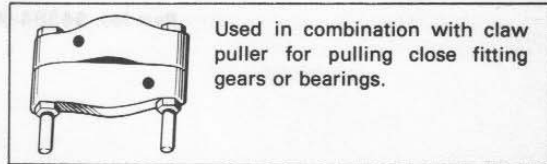

Used in combination with claw puller for pulling close fitting gears or bearings.

Part No. 95637-46 Wedge Attachment for Claw Puller

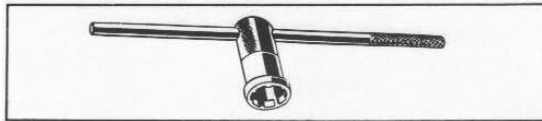

Part No. 94645-41 Clutch Hub Nut Wrench

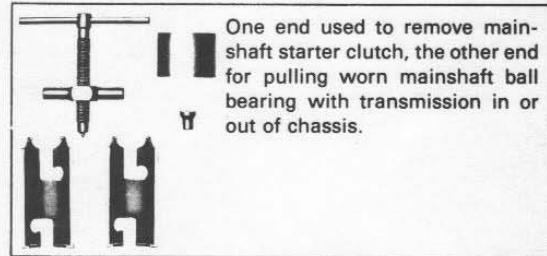

One end used to remove mainshaft starter clutch, the other end for pulling worn mainshaft ball bearing with transmission in or out of chassis.

Part No. 95650-42 Transmission Mainshaft Starter Clutch and Bearing Puller

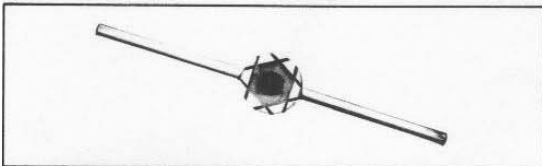

Part No. 94660-37 Countershaft Sprocket Locknut Wrench

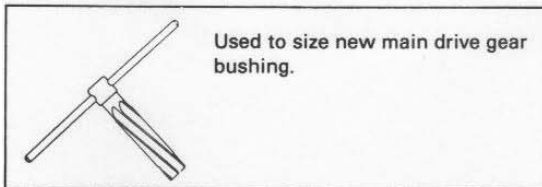

Used to size new main drive gear bushing.

Part No. 94825-31 Transmission Main Drive Gear Bushing Reamer

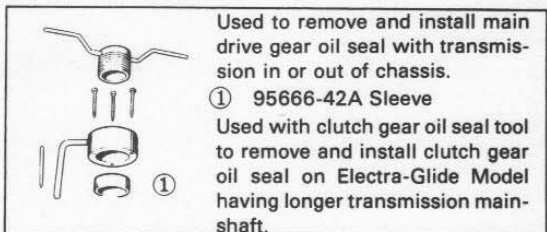

Used to remove and install main drive gear oil seal with transmission in or out of chassis.

① 95666-42A Sleeve
Used with clutch gear oil seal tool to remove and install clutch gear oil seal on Electra-Glide Model having longer transmission mainshaft.

Part No. 95660-42 Main Drive Gear Oil Seal Tool

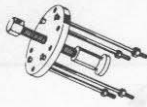

Four holes fit clutch hub studs. Four bolts fit tapped holes in chain housing.

Part No. 95960-41A Clutch Hub and Chain Housing Puller

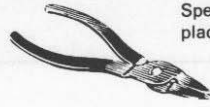

Special pliers for removing and replacing lock ring.

Part No. 96216-49 Internal Lock Ring Pliers Large

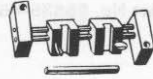

Used to accurately set and align transmission shifter forks.

Part No. 96384-39 Fork Shifter Gauge

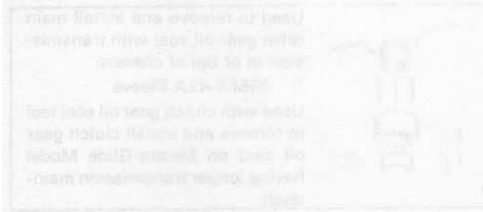
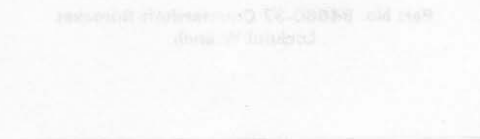
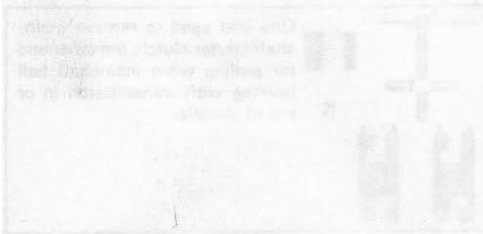
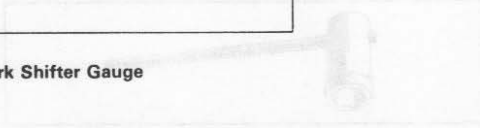

TABLE OF CONTENTS

	PAGE
General	5-1
Wiring	5-2
Switches	5-30
Lamps	5-35
Charging System (1975 and Earlier)	5-37
Charging System (1976 and Later)	5-43
Circuit Breaker	5-47
Ignition Coil	5-51
Spark Plugs	5-53
Battery	5-55
Horn	5-57
Starter Motor	5-59
Tools	5-63

GENERAL

SPECIFICATIONS

Ignition Coil, double secondary outlet

Spark timing

Breaker points setting018 in. gap
Spark occurs at 34° to 36° BTC fully advanced
Approx. 5° BTC fully retarded
Cylinder variance Not to exceed 3°

Spark plug

Type (1974 and earlier) Harley-Davidson No. 3-4
Type (1975 and later) Harley-Davidson No. 5-6
Harley-Davidson No. 5R6 (Resistor type)
Size 14 mm
Gap028-.033 in.
Tightening torque 18-22 ft-lbs

Battery

FL/FLH 12 volt, 32 amp hr.
FX 12 volt, 7 amp hr.
FXE/FXS 12 volt, 19 amp hr

Starter

FL/FLH/FXE/FXS Electric, 12 volt
Bendix drive

FX Manual

Rectifier-regulator Voltage control with
ambient compensation

Alternator Integral permanent magnet design -
225 watts

Horn Electric vibrating

Lights

Headlight (sealed beam)

FL/FLH 50W lower, 60W upper
FX 35W lower, 45W upper

Stop light 32 C.P.

Tail light 4 C.P.

WIRING

1970 FL/FLH WIRING DIAGRAM KEY

- | | |
|---|---------------------------------------|
| 1. Front terminal board (terminals 1 to 13) | 38. Speedometer light |
| 14. Switch tail lamp terminal | 39. Headlamp |
| 15. Switch ignition terminal | 40. Neutral indicator light |
| 16. Switch terminal (not used with standard wiring) | 41. Neutral switch |
| 17. Switch headlamp terminal | 42. Starter button |
| 18. Switch supply terminal | 43. Oil signal light |
| 19. Regulator-rectifier module | 44. Horn |
| 20. Alternator to module connector plug | 45. High beam indicator lamp |
| 21. Alternator stator | 46. Overload circuit breaker |
| 22. Tail and stop lamp | 47. Starter relay |
| 23. Battery positive terminal | 48. Direction signal switch |
| 24. Battery negative terminal | 49. Direction signal flasher |
| 25. Oil pressure signal switch | 50. Left front direction lamp |
| 26. Handlebar headlamp switch | 51. Right front direction lamp |
| 27. Horn switch | 52. Left rear direction lamp |
| 28. Ignition circuit breaker | 53. Right rear direction lamp |
| 29. Stop lamp switch - rear | 54. Left direction signal pilot lamp |
| 30. Starter solenoid | 55. Right direction signal pilot lamp |
| 31. Starter motor | 56. Stop lamp switch - front |
| 32. Ignition coil | 57. Connector |
| 33. Rear terminal board terminal - top | 58. Terminal board mounting screw |
| 34. Rear terminal board terminal | 59. Transmission stud |
| 35. Rear terminal board terminal | 60. Frame lug bolt |
| 36. Rear terminal board terminal | 61. Handlebar |
| 37. Rear terminal board terminal - bottom | |

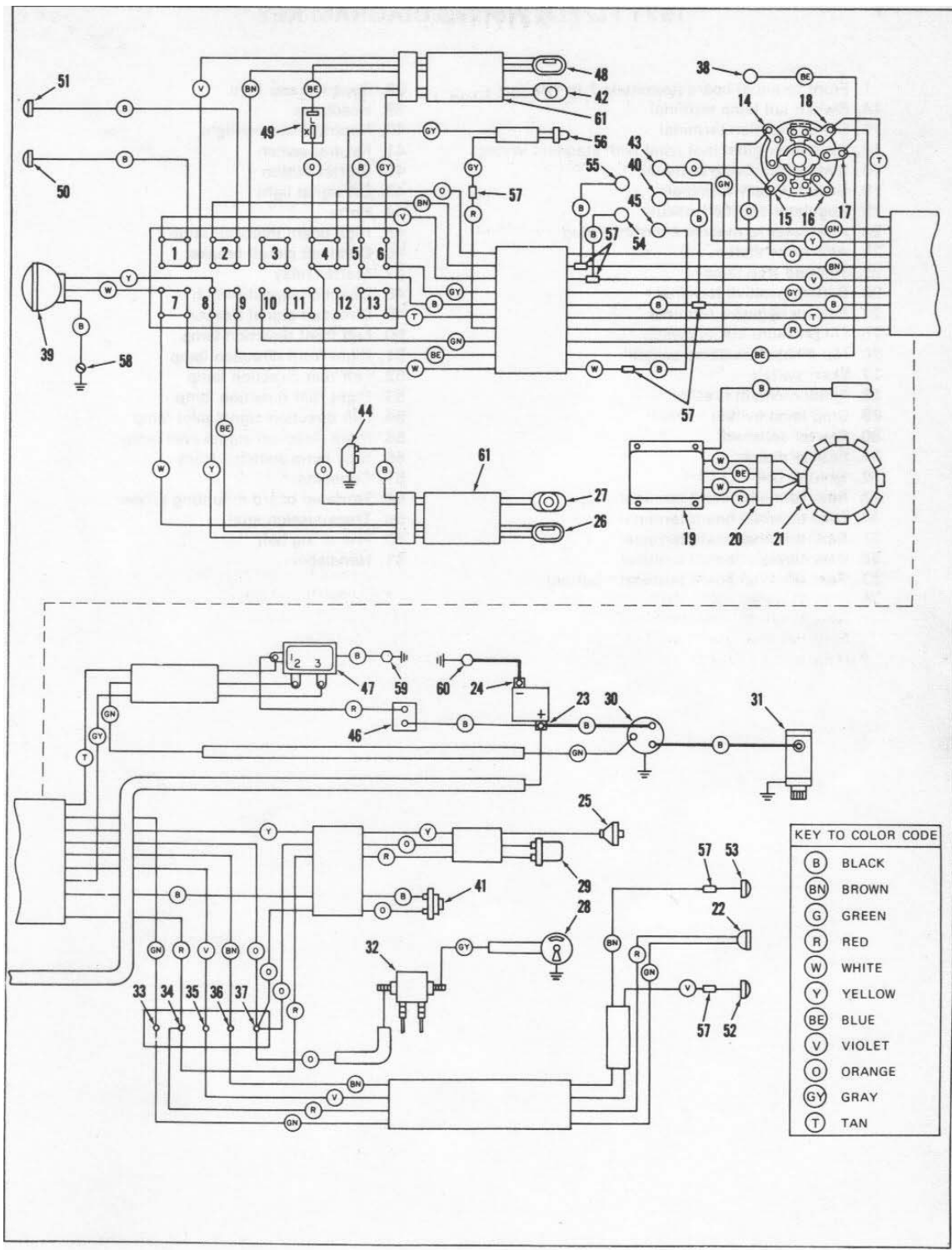
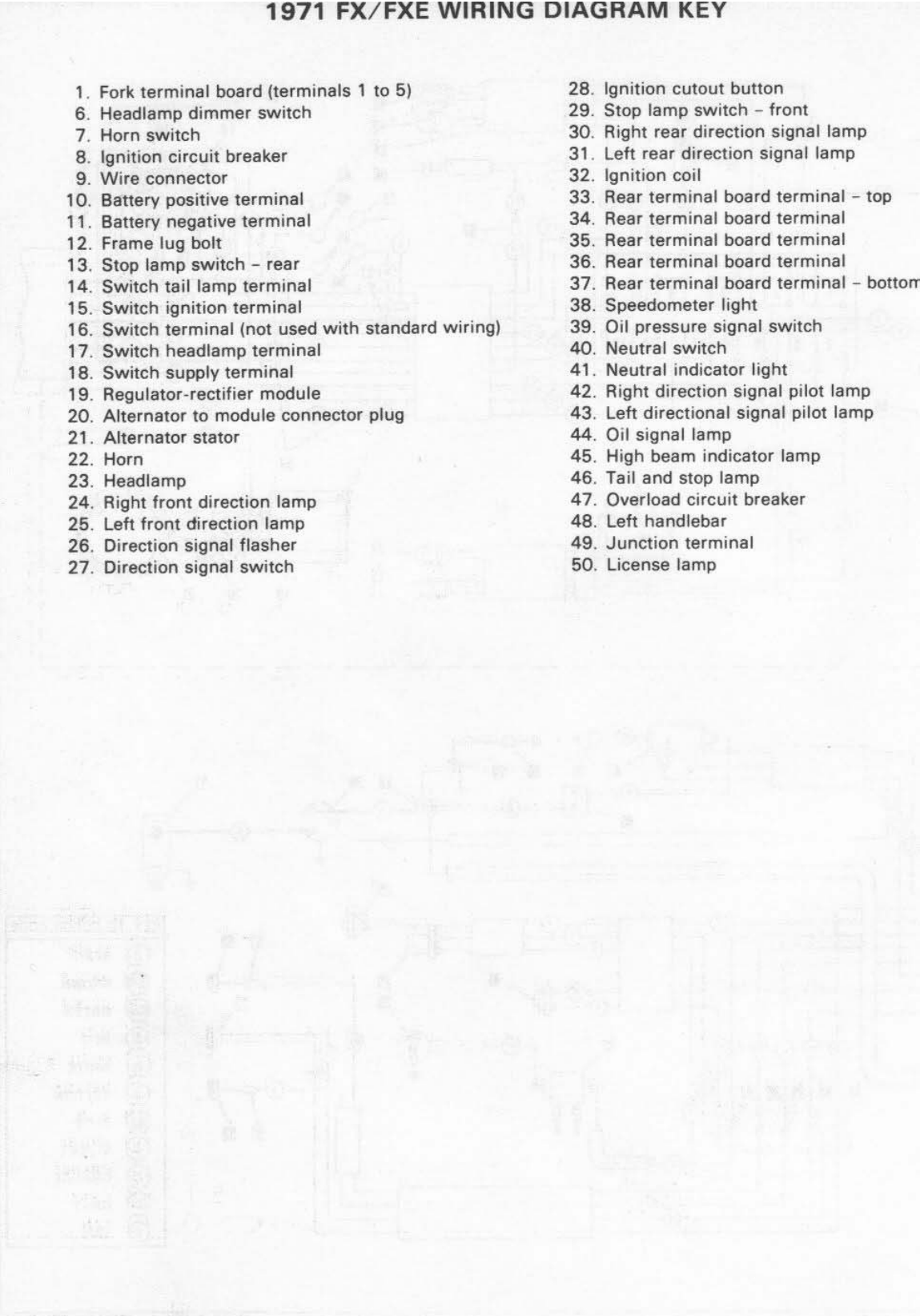

Figure 5-1. 1970 FL/FLH 1200 Wiring Diagram

1971 FL/FLH WIRING DIAGRAM KEY

-
- | | |
|---|---------------------------------------|
| 1. Front terminal board (terminals 1 to 13) | 38. Speedometer light |
| 14. Switch tail lamp terminal | 39. Headlamp |
| 15. Switch ignition terminal | 40. Neutral indicator light |
| 16. Switch terminal (not used with standard wiring) | 41. Neutral switch |
| 17. Switch headlamp terminal | 42. Starter button |
| 18. Switch supply terminal | 43. Oil signal light |
| 19. Regulator-rectifier module | 44. Horn |
| 20. Alternator to module connector plug | 45. High beam indicator lamp |
| 21. Alternator stator | 46. Overload circuit breaker |
| 22. Tail and stop lamp | 47. Starter relay |
| 23. Battery positive terminal | 48. Direction signal switch |
| 24. Battery negative terminal | 49. Direction signal flasher |
| 25. Oil pressure signal switch | 50. Left front direction lamp |
| 26. Handlebar headlamp switch | 51. Right front direction lamp |
| 27. Horn switch | 52. Left rear direction lamp |
| 28. Ignition circuit breaker | 53. Right rear direction lamp |
| 29. Stop lamp switch - rear | 54. Left direction signal pilot lamp |
| 30. Starter solenoid | 55. Right direction signal pilot lamp |
| 31. Starter motor | 56. Stop lamp switch - front |
| 32. Ignition coil | 57. Connector |
| 33. Rear terminal board terminal - top | 58. Terminal board mounting screw |
| 34. Rear terminal board terminal | 59. Transmission stud |
| 35. Rear terminal board terminal | 60. Frame lug bolt |
| 36. Rear terminal board terminal | 61. Handlebar |
| 37. Rear terminal board terminal - bottom | |

1971 FX/FXE WIRING DIAGRAM KEY

- 
1. Fork terminal board (terminals 1 to 5)
 6. Headlamp dimmer switch
 7. Horn switch
 8. Ignition circuit breaker
 9. Wire connector
 10. Battery positive terminal
 11. Battery negative terminal
 12. Frame lug bolt
 13. Stop lamp switch - rear
 14. Switch tail lamp terminal
 15. Switch ignition terminal
 16. Switch terminal (not used with standard wiring)
 17. Switch headlamp terminal
 18. Switch supply terminal
 19. Regulator-rectifier module
 20. Alternator to module connector plug
 21. Alternator stator
 22. Horn
 23. Headlamp
 24. Right front direction lamp
 25. Left front direction lamp
 26. Direction signal flasher
 27. Direction signal switch
 28. Ignition cutout button
 29. Stop lamp switch - front
 30. Right rear direction signal lamp
 31. Left rear direction signal lamp
 32. Ignition coil
 33. Rear terminal board terminal - top
 34. Rear terminal board terminal
 35. Rear terminal board terminal
 36. Rear terminal board terminal
 37. Rear terminal board terminal - bottom
 38. Speedometer light
 39. Oil pressure signal switch
 40. Neutral switch
 41. Neutral indicator light
 42. Right direction signal pilot lamp
 43. Left directional signal pilot lamp
 44. Oil signal lamp
 45. High beam indicator lamp
 46. Tail and stop lamp
 47. Overload circuit breaker
 48. Left handlebar
 49. Junction terminal
 50. License lamp

1972 FL/FLH WIRING DIAGRAM KEY

- | | |
|---|---|
| <ul style="list-style-type: none"> 1. Front terminal board (terminals 1 to 13) 14. Switch tail lamp terminal 15. Switch ignition terminal 16. Switch terminal (not used with standard wiring) 17. Switch headlamp terminal 18. Switch supply terminal 19. Regulator-rectifier module 20. Alternator to module connector plug 21. Alternator stator 22. Tail and stop lamp 23. Battery positive terminal 24. Battery negative terminal 25. Oil pressure signal switch 26. Handlebar headlamp switch 27. Horn switch 28. Ignition circuit breaker 29. Stop lamp switch - rear 30. Starter solenoid 31. Starter motor 32. Ignition coil 33. Rear terminal board terminal - top 34. Rear terminal board terminal 35. Rear terminal board terminal 36. Rear terminal board terminal 37. Rear terminal board terminal - bottom | <ul style="list-style-type: none"> 38. Speedometer light 39. Headlamp 40. Neutral indicator light 41. Neutral switch 42. Starter button 43. Oil signal light 44. Horn 45. High beam indicator lamp 46. Overload circuit breaker 47. Starter relay 48. Right direction signal switch 49. Direction signal flasher 50. Left front direction lamp 51. Right front direction lamp 52. Left rear direction lamp 53. Right rear direction lamp 54. Left direction signal pilot lamp 55. Right direction signal pilot lamp 56. Stop lamp switch - front 57. Connector 58. Terminal board mounting screw 59. Transmission stud 60. Frame lug bolt 61. Handlebar 62. Left direction signal switch |
|---|---|



Wiring Diagram 1972 FL/FLH

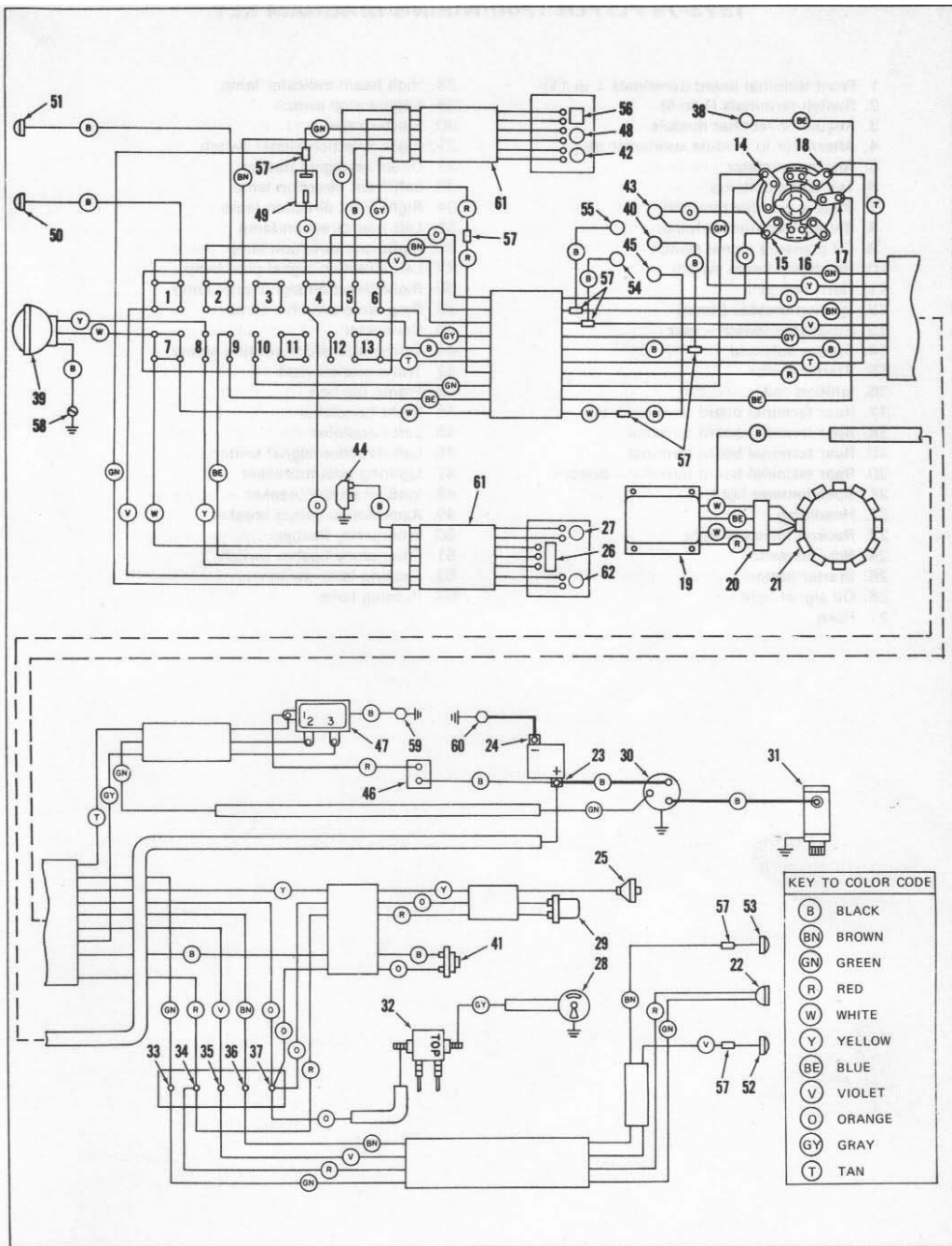

Figure 5-1C. 1972 FL/FLH 1200 Wiring Diagram

1973-74 FL/FLH 1200 WIRING DIAGRAM KEY

- | | |
|---|--|
| <ol style="list-style-type: none"> 1. Front terminal board (terminals 1 to 11) 2. Switch terminals (1 to 6) 3. Regulator-rectifier module 4. Alternator to module connector plug 5. Alternator stator 6. Tail and stop lamp 7. Battery positive terminal 8. Battery negative terminal 9. Oil pressure signal switch 10. Headlamp beam switch 11. Horn switch 12. Ignition breaker (timer) 13. Stop lamp switch - rear 14. Starter solenoid 15. Starter motor 16. Ignition coil 17. Rear terminal board terminal - top 18. Rear terminal board terminal 19. Rear terminal board terminal 20. Rear terminal board terminal - bottom 21. Speedometer light 22. Headlamp 23. Neutral indicator light 24. Neutral switch 25. Starter button 26. Oil signal light 27. Horn | <ol style="list-style-type: none"> 28. High beam indicator lamp 29. Engine stop switch 30. Starter relay 31. Right direction signal switch 32. Direction signal flasher 33. Left front direction lamp 34. Right front direction lamp 35. Left rear direction lamp 36. Right rear direction lamp 37. Left direction signal pilot lamp 38. Right direction signal pilot lamp 39. Stop lamp switch - front 40. Connector 41. Terminal board mounting screw 42. Transmission stud 43. Frame lug bolt 44. Right handlebar 45. Left handlebar 46. Left direction signal switch 47. Lighting circuit breaker 48. Ignition circuit breaker 49. Accessories circuit breaker 50. Emergency flasher 51. Emergency flasher switch 52. Passing lamp switch 53. Passing lamp |
|---|--|

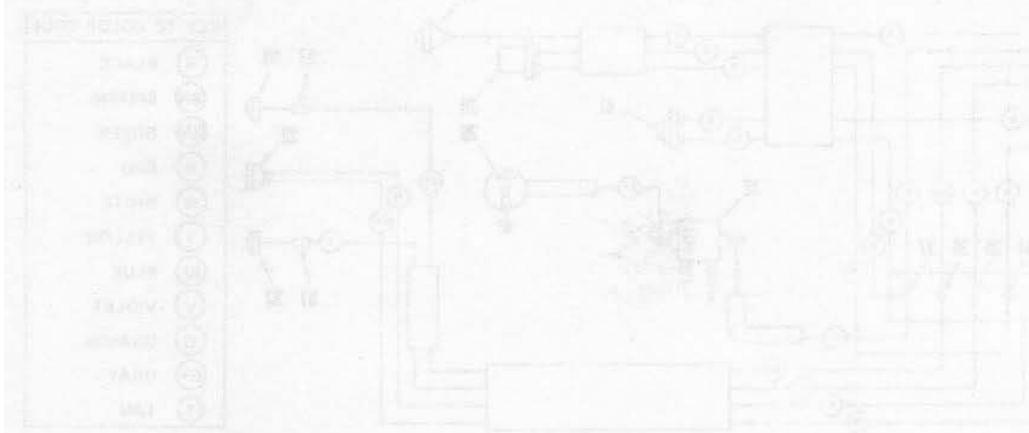

Figure 8-10 1973 FL/FLH 1200 Wiring Diagram

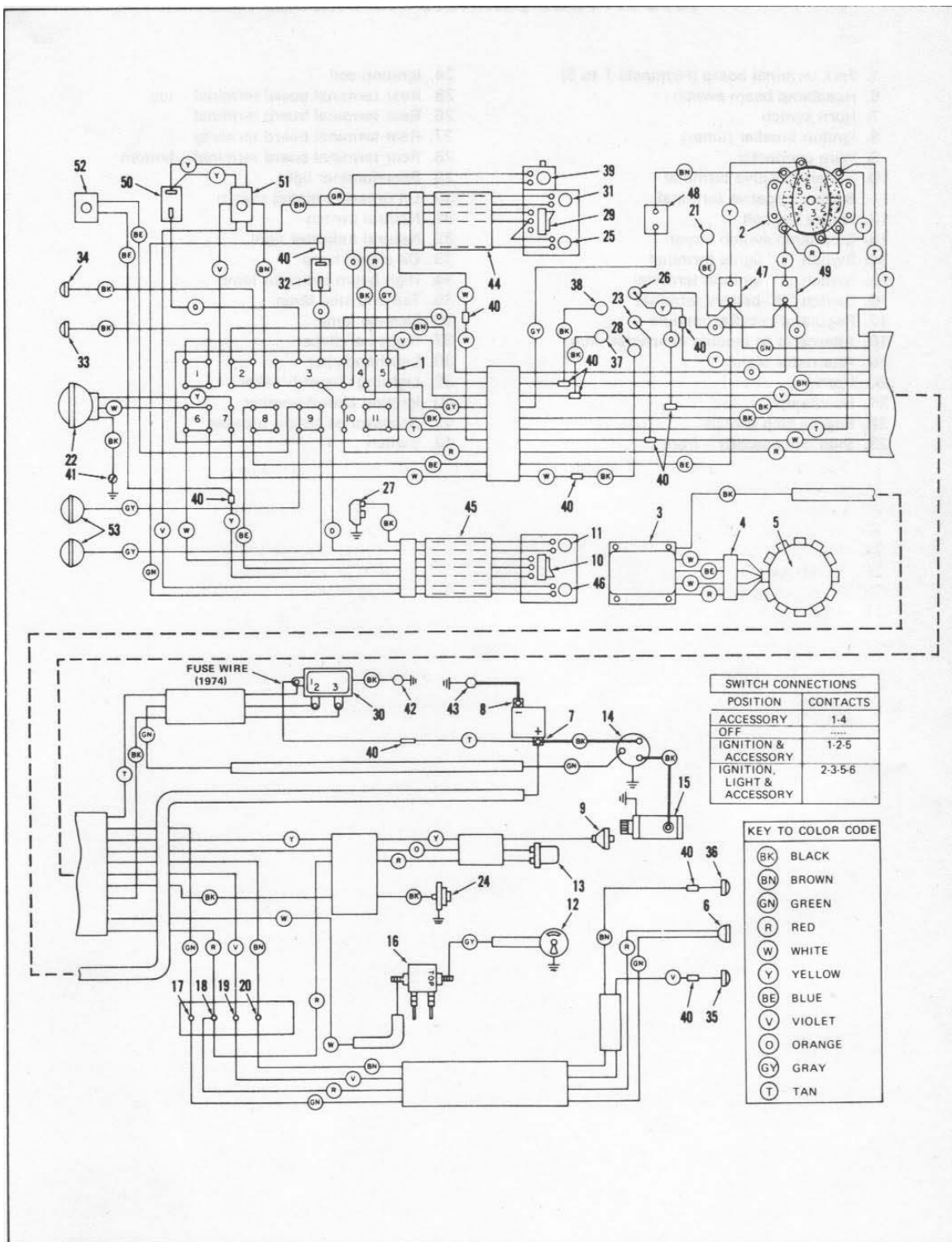

Figure 5-1D. 1973-74 FL/FLH 1200 Wiring Diagram

1973 FX 1200 WIRING DIAGRAM KEY

1. Fork terminal board (terminals 1 to 5)
6. Headlamp beam switch
7. Horn switch
8. Ignition breaker (timer)
9. Wire connector
10. Battery positive terminal
11. Battery negative terminal
12. Frame lug bolt
13. Stop lamp switch - rear
14. Switch "L" lights terminal
15. Switch "I" ignition terminal
16. Switch "B" battery terminal
17. Regulator-rectifier module
18. Alternator to module connector plug
19. Alternator stator
20. Horn
21. Headlamp
22. Engine stop switch
23. Stop lamp switch - front
24. Ignition coil
25. Rear terminal board terminal - top
26. Rear terminal board terminal
27. Rear terminal board terminal
28. Rear terminal board terminal - bottom
29. Speedometer light
30. Oil pressure signal switch
31. Neutral switch
32. Neutral indicator light
33. Oil signal lamp
34. High beam indicator lamp
35. Tail and stop lamp
36. License lamp
37. Right handlebar
38. Left handlebar
39. Lighting circuit breaker
40. Ignition circuit breaker
41. Accessories circuit breaker
42. Switch

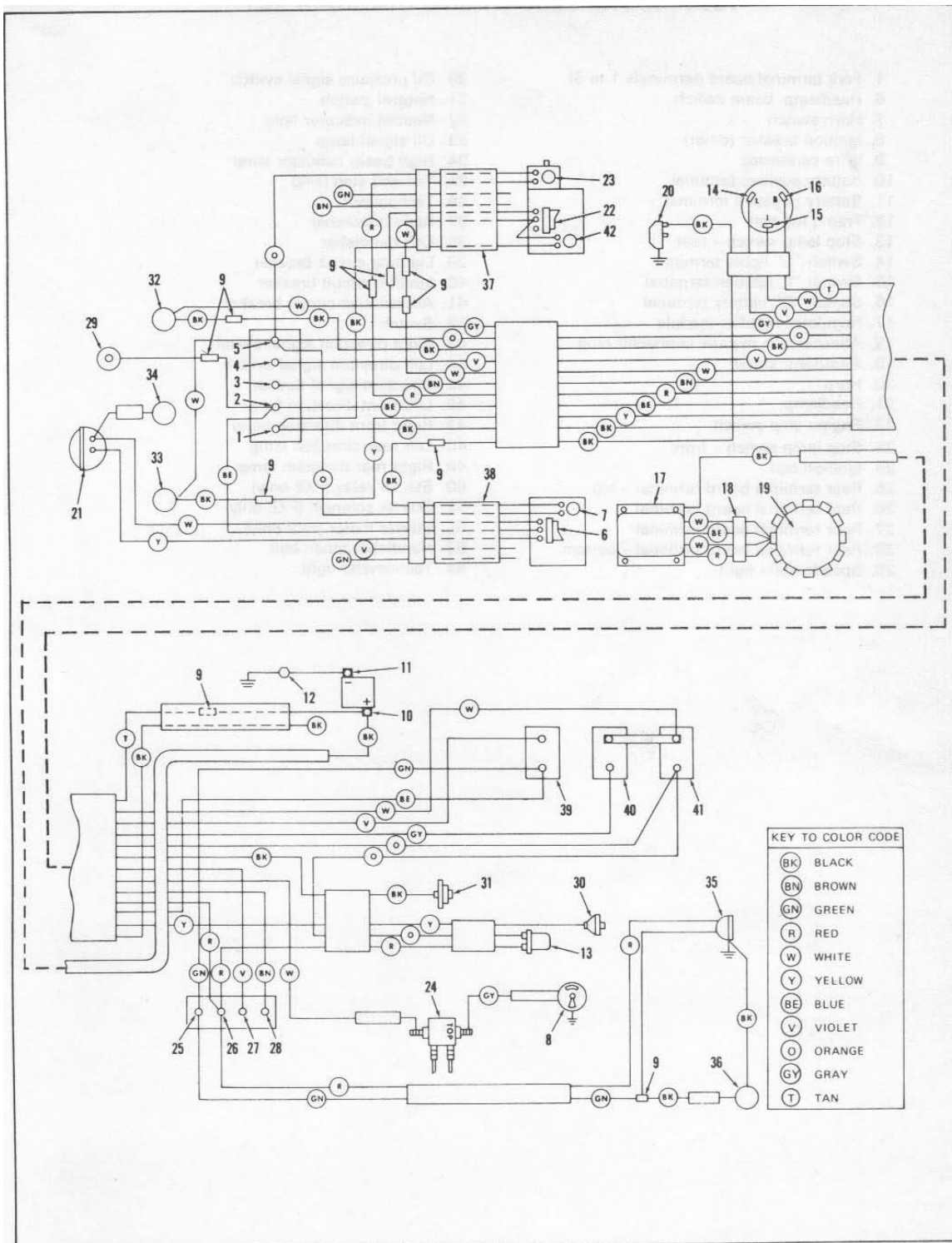
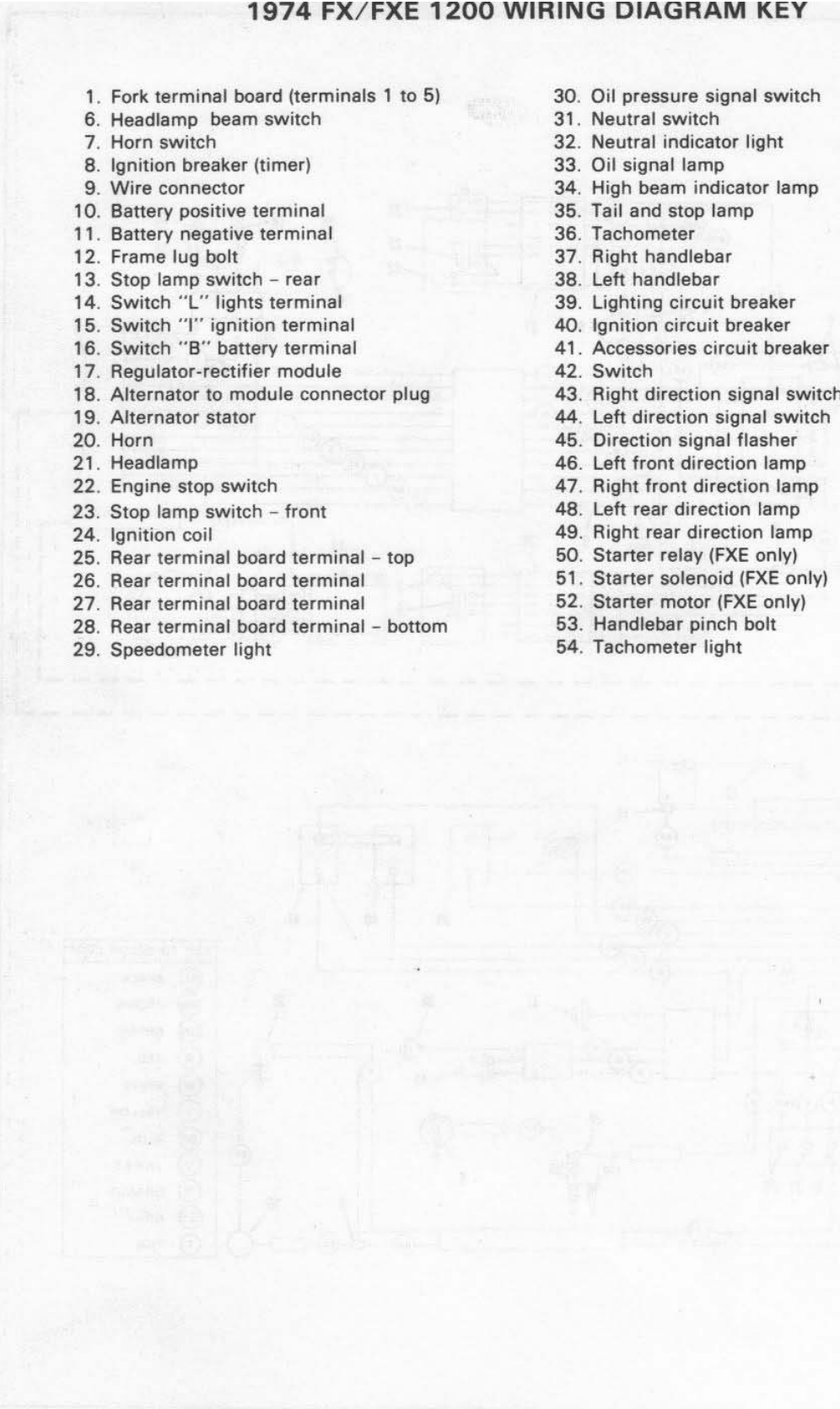

Figure 5-1E. 1973 FX 1200 Wiring Diagram

1974 FX/FXE 1200 WIRING DIAGRAM KEY

- 
1. Fork terminal board (terminals 1 to 5)
 6. Headlamp beam switch
 7. Horn switch
 8. Ignition breaker (timer)
 9. Wire connector
 10. Battery positive terminal
 11. Battery negative terminal
 12. Frame lug bolt
 13. Stop lamp switch - rear
 14. Switch "L" lights terminal
 15. Switch "I" ignition terminal
 16. Switch "B" battery terminal
 17. Regulator-rectifier module
 18. Alternator to module connector plug
 19. Alternator stator
 20. Horn
 21. Headlamp
 22. Engine stop switch
 23. Stop lamp switch - front
 24. Ignition coil
 25. Rear terminal board terminal - top
 26. Rear terminal board terminal
 27. Rear terminal board terminal
 28. Rear terminal board terminal - bottom
 29. Speedometer light
 30. Oil pressure signal switch
 31. Neutral switch
 32. Neutral indicator light
 33. Oil signal lamp
 34. High beam indicator lamp
 35. Tail and stop lamp
 36. Tachometer
 37. Right handlebar
 38. Left handlebar
 39. Lighting circuit breaker
 40. Ignition circuit breaker
 41. Accessories circuit breaker
 42. Switch
 43. Right direction signal switch
 44. Left direction signal switch
 45. Direction signal flasher
 46. Left front direction lamp
 47. Right front direction lamp
 48. Left rear direction lamp
 49. Right rear direction lamp
 50. Starter relay (FXE only)
 51. Starter solenoid (FXE only)
 52. Starter motor (FXE only)
 53. Handlebar pinch bolt
 54. Tachometer light

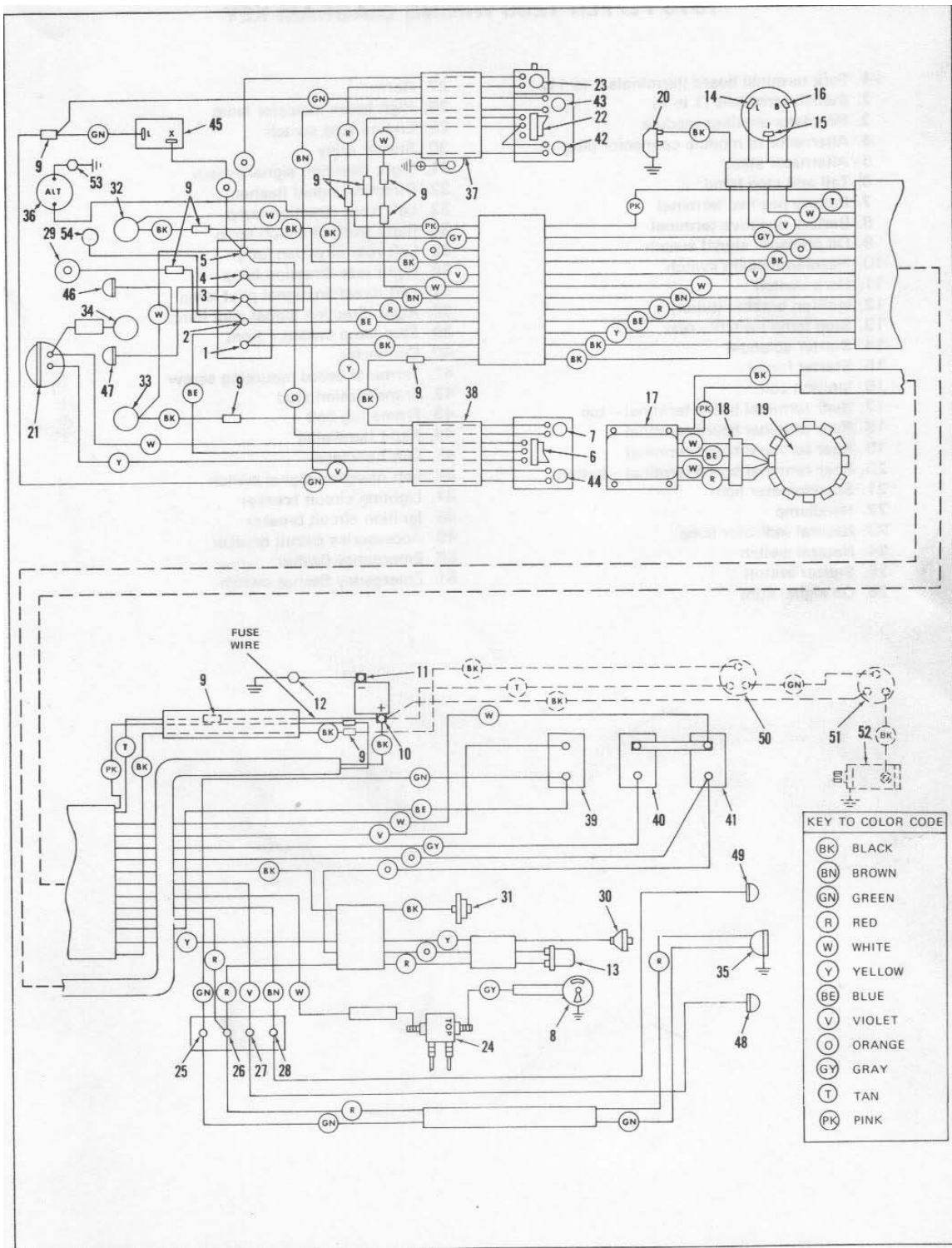
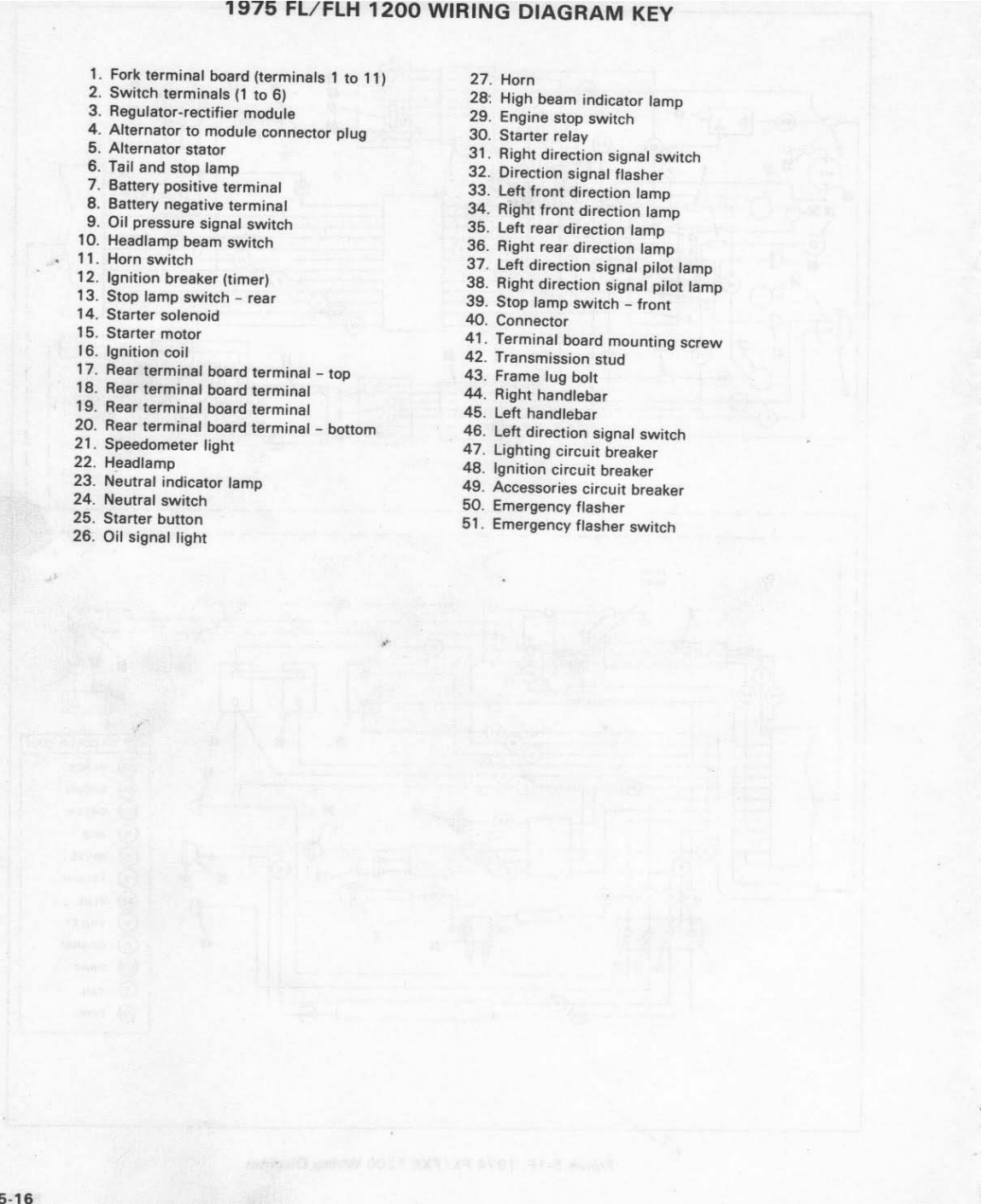

Figure 5-1F. 1974 FX/FXE 1200 Wiring Diagram

1975 FL/FLH 1200 WIRING DIAGRAM KEY

- 
1. Fork terminal board (terminals 1 to 11)
 2. Switch terminals (1 to 6)
 3. Regulator-rectifier module
 4. Alternator to module connector plug
 5. Alternator stator
 6. Tail and stop lamp
 7. Battery positive terminal
 8. Battery negative terminal
 9. Oil pressure signal switch
 10. Headlamp beam switch
 11. Horn switch
 12. Ignition breaker (timer)
 13. Stop lamp switch - rear
 14. Starter solenoid
 15. Starter motor
 16. Ignition coil
 17. Rear terminal board terminal - top
 18. Rear terminal board terminal
 19. Rear terminal board terminal
 20. Rear terminal board terminal - bottom
 21. Speedometer light
 22. Headlamp
 23. Neutral indicator lamp
 24. Neutral switch
 25. Starter button
 26. Oil signal light
 27. Horn
 28. High beam indicator lamp
 29. Engine stop switch
 30. Starter relay
 31. Right direction signal switch
 32. Direction signal flasher
 33. Left front direction lamp
 34. Right front direction lamp
 35. Left rear direction lamp
 36. Right rear direction lamp
 37. Left direction signal pilot lamp
 38. Right direction signal pilot lamp
 39. Stop lamp switch - front
 40. Connector
 41. Terminal board mounting screw
 42. Transmission stud
 43. Frame lug bolt
 44. Right handlebar
 45. Left handlebar
 46. Left direction signal switch
 47. Lighting circuit breaker
 48. Ignition circuit breaker
 49. Accessories circuit breaker
 50. Emergency flasher
 51. Emergency flasher switch

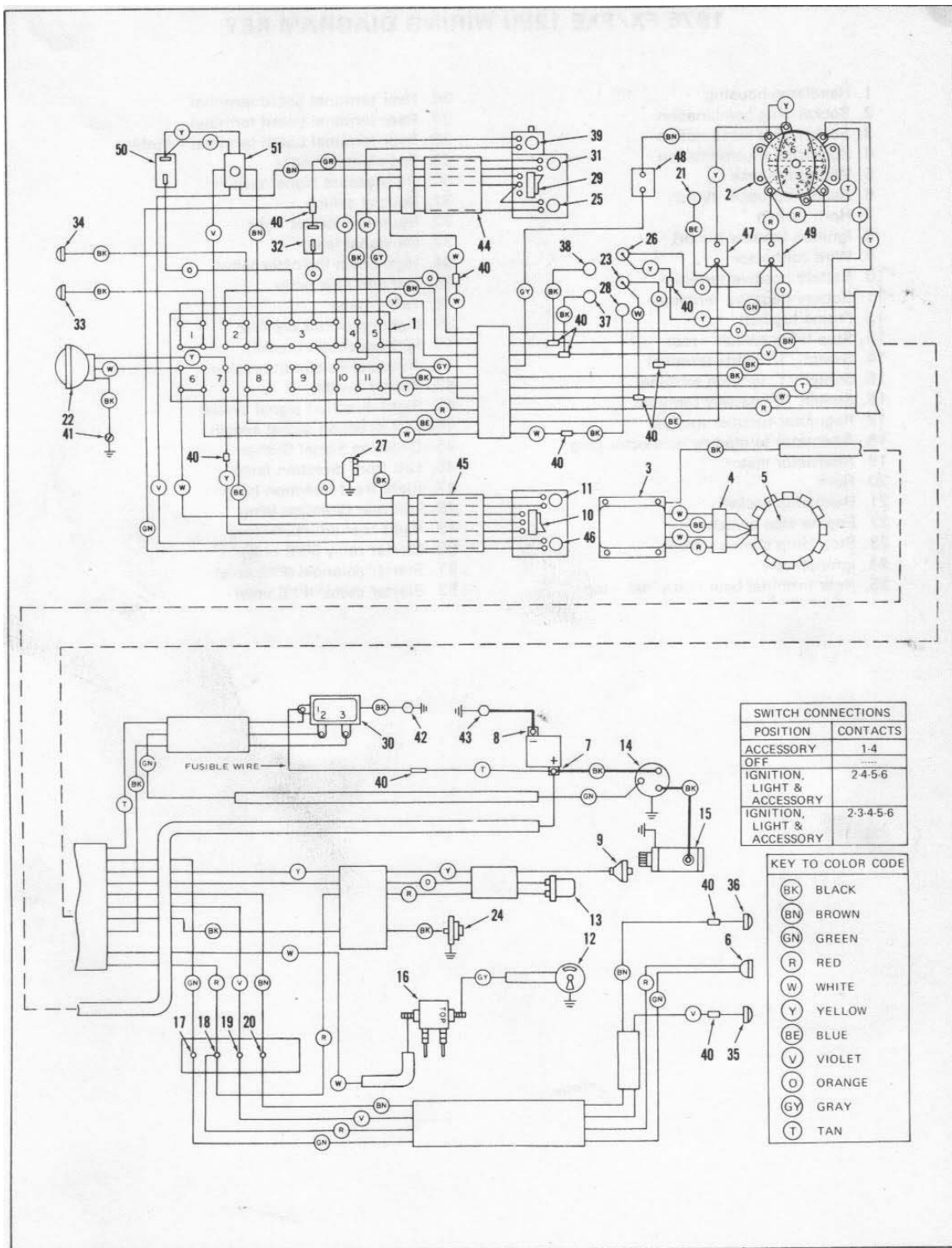

Figure 5-1G. 1975 FL/FLH 1200 Wiring Diagram

1975 FX/FXE 1200 WIRING DIAGRAM KEY

1. Headlamp housing
2. Socket-plug combination
3. Socket-plug combination
4. Socket-plug combination
5. Wiring harness
6. Headlamp beam switch
7. Horn switch
8. Ignition breaker (timer)
9. Wire connector
10. Battery positive terminal
11. Battery negative terminal
12. Frame lug bolt
13. Stop lamp switch - rear
14. Switch "L" lights terminal
15. Switch "I" ignition terminal
16. Switch "B" battery terminal
17. Regulator-rectifier module
18. Alternator to module connector plug
19. Alternator stator
20. Horn
21. Headlamp socket
22. Engine stop switch
23. Stop lamp switch - front
24. Ignition coil
25. Rear terminal board terminal - top
26. Rear terminal board terminal
27. Rear terminal board terminal
28. Rear terminal board terminal - bottom
29. Speedometer light
30. Oil pressure signal switch
31. Neutral switch
32. Neutral indicator light
33. Oil signal lamp
34. High beam indicator lamp
35. Tail and stop lamp
36. Tachometer
39. Lighting circuit breaker
40. Ignition circuit breaker
41. Accessories circuit breaker
42. Starter switch
43. Right direction signal switch
44. Left direction signal switch
45. Direction signal flasher
46. Left front direction lamp
47. Right front direction lamp
48. Left rear direction lamp
49. Right rear direction lamp
50. Starter relay (FXE only)
51. Starter solenoid (FXE only)
52. Starter motor (FXE only)

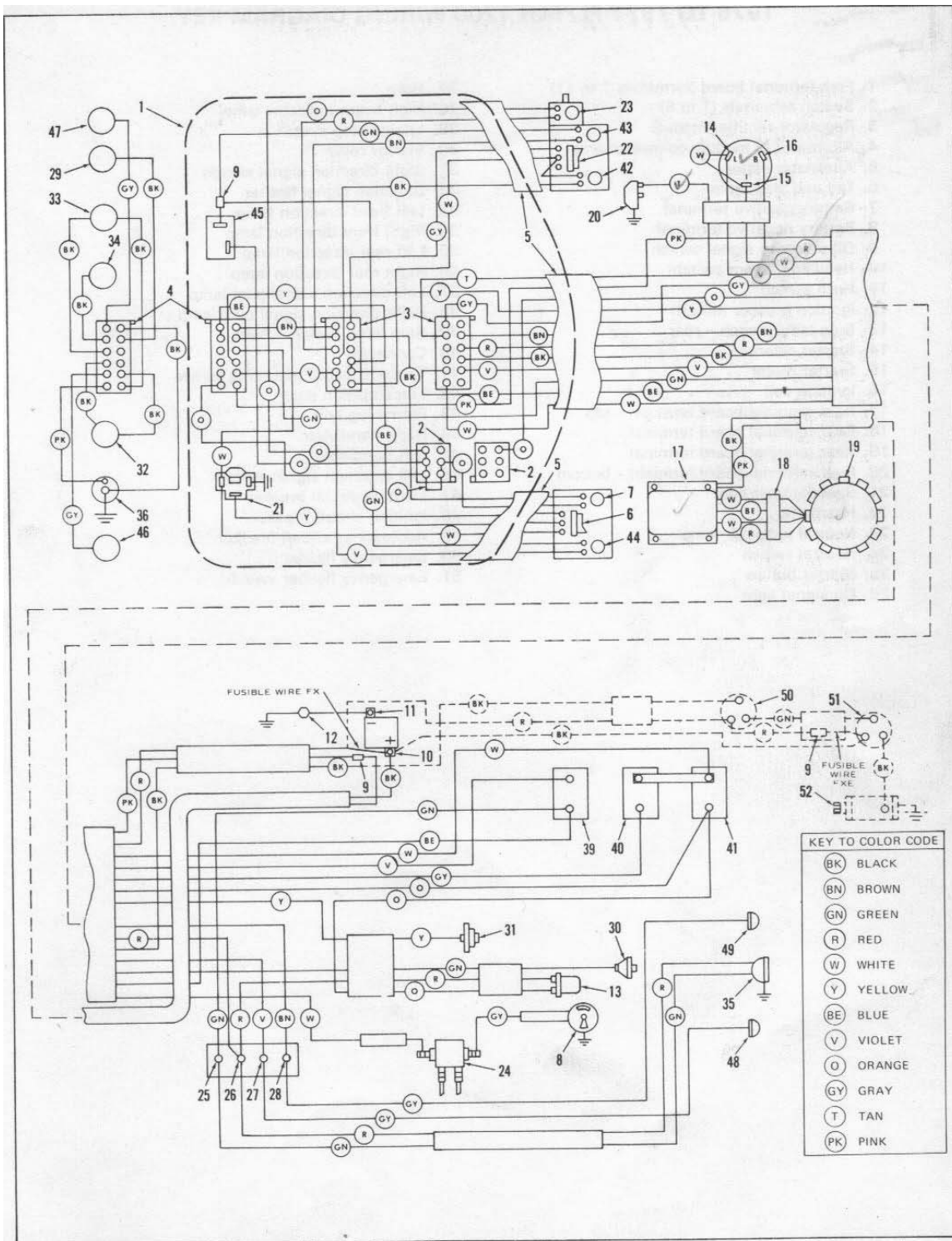

Figure 5-1H. 1975 FX/FXE 1200 Wiring Diagram

1976 TO 1977 FL/FLH 1200 WIRING DIAGRAM KEY

1. Fork terminal board (terminals 1 to 11)
2. Switch terminals (1 to 6)
3. Regulator-rectifier module
4. Alternator to module connector plug
5. Alternator stator
6. Tail and stop lamp
7. Battery positive terminal
8. Battery negative terminal
9. Oil pressure signal switch
10. Headlamp beam switch
11. Horn switch
12. Ignition breaker (timer)
13. Stop lamp switch - rear
14. Starter solenoid
15. Starter motor
16. Ignition coil
17. Rear terminal board terminal - top
18. Rear terminal board terminal
19. Rear terminal board terminal
20. Rear terminal board terminal - bottom
21. Speedometer light
22. Headlamp
23. Neutral indicator lamp
24. Neutral switch
25. Starter button
26. Oil signal light
27. Horn
28. High beam indicator lamp
29. Engine stop switch
30. Starter relay
31. Right direction signal switch
32. Direction signal flasher
33. Left front direction lamp
34. Right front direction lamp
35. Left rear direction lamp
36. Right rear direction lamp
37. Left direction signal pilot lamp
38. Right direction signal pilot lamp
39. Stop lamp switch - front
40. Connector
41. Terminal board mounting screw
42. Transmission stud
43. Frame lug bolt
44. Right handlebar
45. Left handlebar
46. Left direction signal switch
47. Lighting circuit breaker
48. Ignition circuit breaker
49. Accessories circuit breaker
50. Emergency flasher
51. Emergency flasher switch

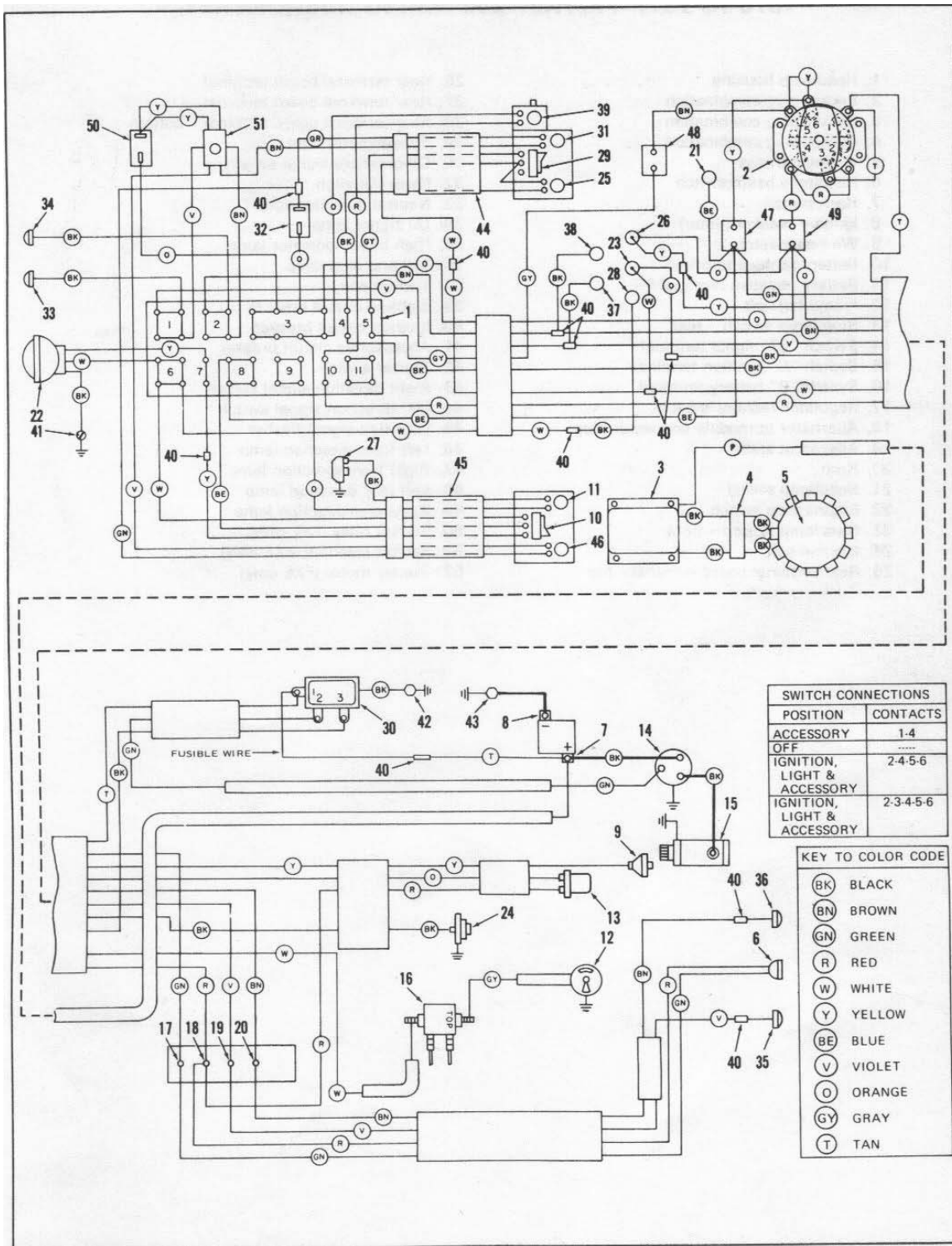

Figure 5-11. 1976 to 1977 FL/FLH 1200 Wiring Diagram

1976 TO 1977 FX/FXE 1200 WIRING DIAGRAM KEY

- | | |
|---|---|
| 1. Headlamp housing | 26. Rear terminal board terminal |
| 2. Socket-plug combination | 27. Rear terminal board terminal |
| 3. Socket-plug combination | 28. Rear terminal board terminal - bottom |
| 4. Socket-plug combination | 29. Speedometer light |
| 5. Wiring harness | 30. Oil pressure signal switch |
| 6. Headlamp beam switch | 31. Neutral switch |
| 7. Horn switch | 32. Neutral indicator light |
| 8. Ignition breaker (timer) | 33. Oil signal lamp |
| 9. Wire connector | 34. High beam indicator lamp |
| 10. Battery positive terminal | 35. Tail and stop lamp |
| 11. Battery negative terminal | 36. Tachometer |
| 12. Frame lug bolt | 39. Lighting circuit breaker |
| 13. Stop lamp switch - rear | 40. Ignition circuit breaker |
| 14. Switch "ST" lights terminal | 41. Accessories circuit breaker |
| 15. Switch "G" ignition terminal | 42. Starter switch |
| 16. Switch "B" battery terminal | 43. Right direction signal switch |
| 17. Regulator-rectifier module | 44. Left direction signal switch |
| 18. Alternator to module connector plug | 45. Direction signal flasher |
| 19. Alternator stator | 46. Left front direction lamp |
| 20. Horn | 47. Right front direction lamp |
| 21. Headlamp socket | 48. Left rear direction lamp |
| 22. Engine stop switch | 49. Right rear direction lamp |
| 23. Stop lamp switch - front | 50. Starter relay (FXE only) |
| 24. Ignition coil | 51. Starter solenoid (FXE only) |
| 25. Rear terminal board terminal - top | 52. Starter motor (FXE only) |

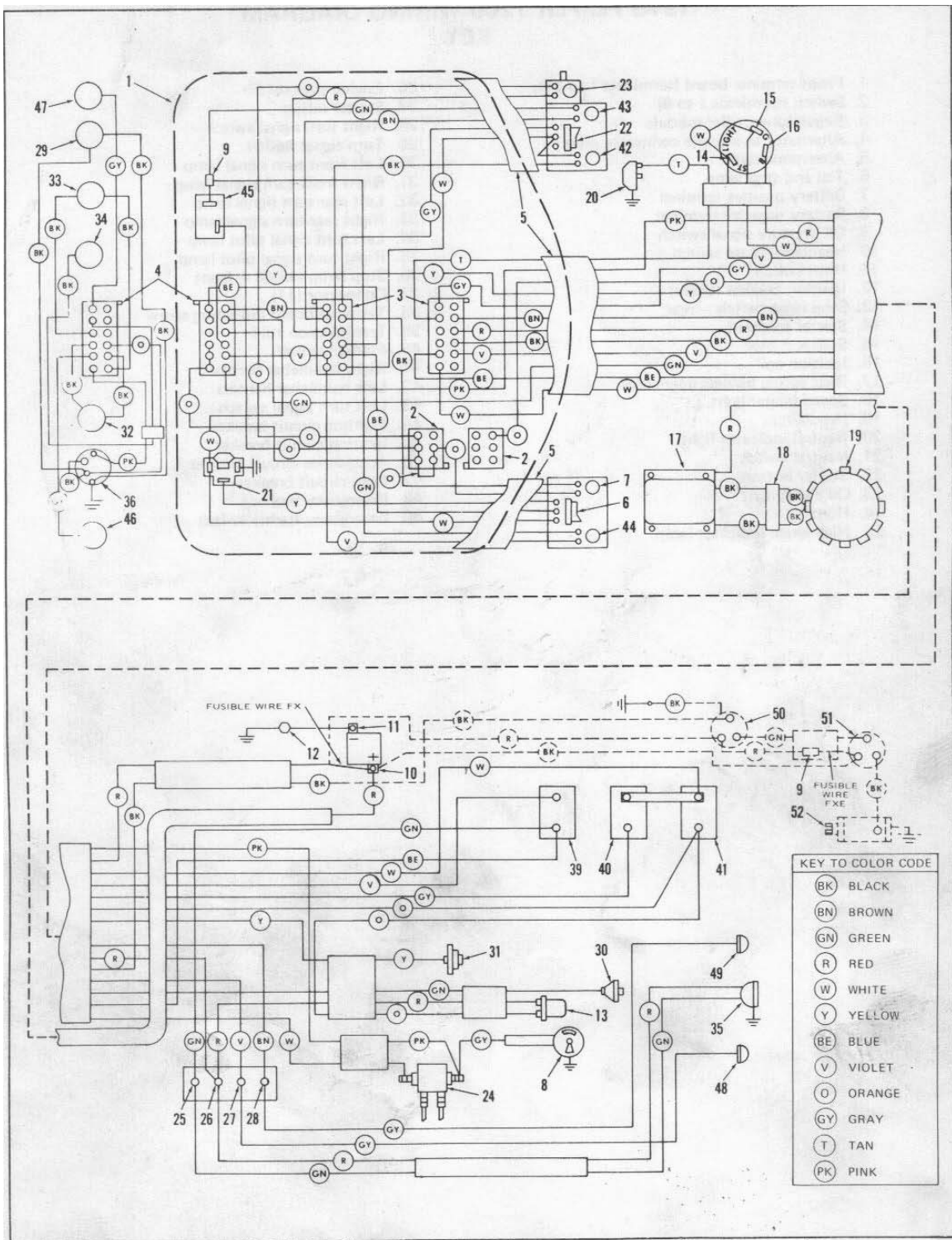
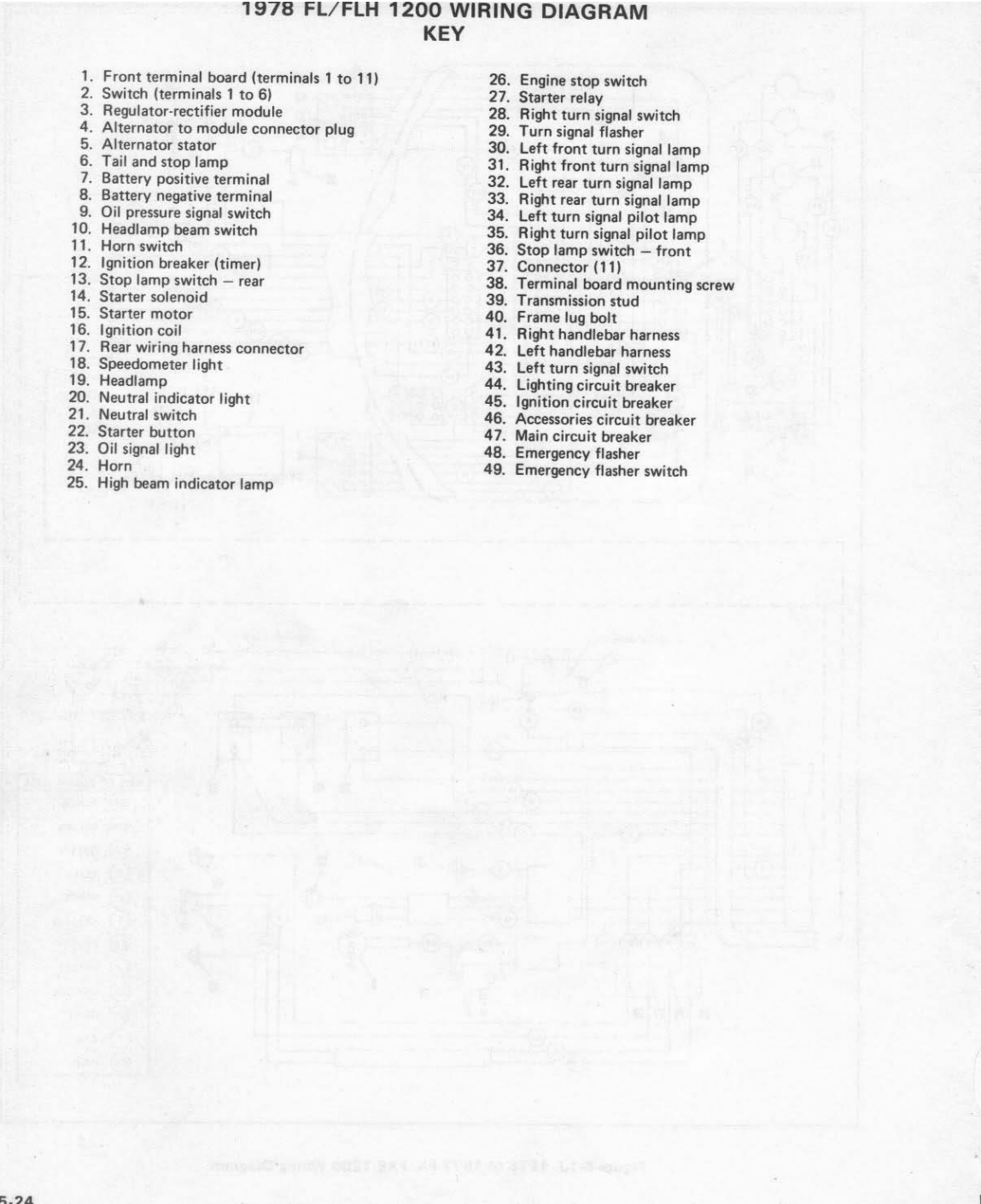

Figure 5-1J. 1976 to 1977 FX/FXE 1200 Wiring Diagram

1978 FL/FLH 1200 WIRING DIAGRAM
KEY

- 
1. Front terminal board (terminals 1 to 11)
 2. Switch (terminals 1 to 6)
 3. Regulator-rectifier module
 4. Alternator to module connector plug
 5. Alternator stator
 6. Tail and stop lamp
 7. Battery positive terminal
 8. Battery negative terminal
 9. Oil pressure signal switch
 10. Headlamp beam switch
 11. Horn switch
 12. Ignition breaker (timer)
 13. Stop lamp switch - rear
 14. Starter solenoid
 15. Starter motor
 16. Ignition coil
 17. Rear wiring harness connector
 18. Speedometer light
 19. Headlamp
 20. Neutral indicator light
 21. Neutral switch
 22. Starter button
 23. Oil signal light
 24. Horn
 25. High beam indicator lamp
 26. Engine stop switch
 27. Starter relay
 28. Right turn signal switch
 29. Turn signal flasher
 30. Left front turn signal lamp
 31. Right front turn signal lamp
 32. Left rear turn signal lamp
 33. Right rear turn signal lamp
 34. Left turn signal pilot lamp
 35. Right turn signal pilot lamp
 36. Stop lamp switch - front
 37. Connector (11)
 38. Terminal board mounting screw
 39. Transmission stud
 40. Frame lug bolt
 41. Right handlebar harness
 42. Left handlebar harness
 43. Left turn signal switch
 44. Lighting circuit breaker
 45. Ignition circuit breaker
 46. Accessories circuit breaker
 47. Main circuit breaker
 48. Emergency flasher
 49. Emergency flasher switch

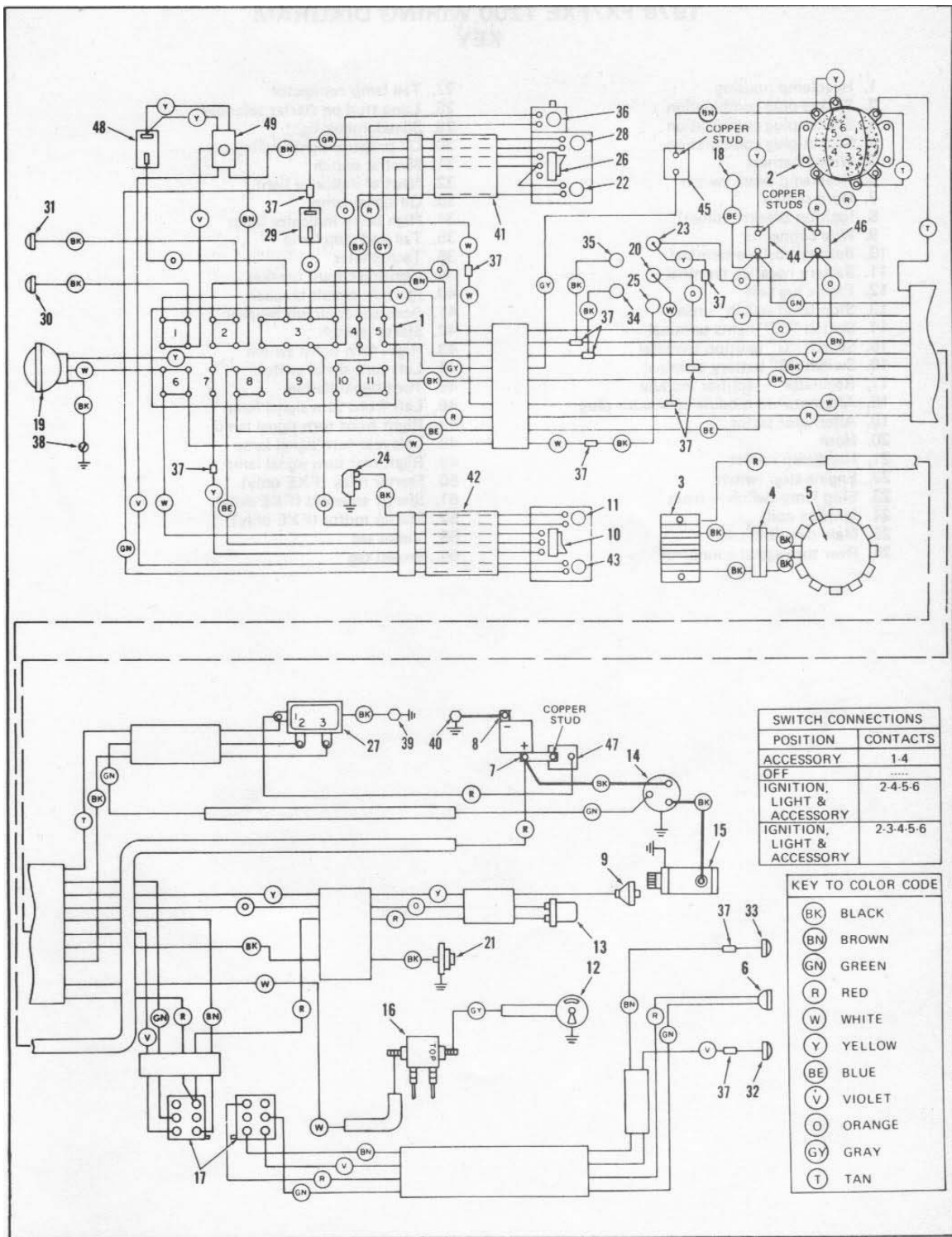
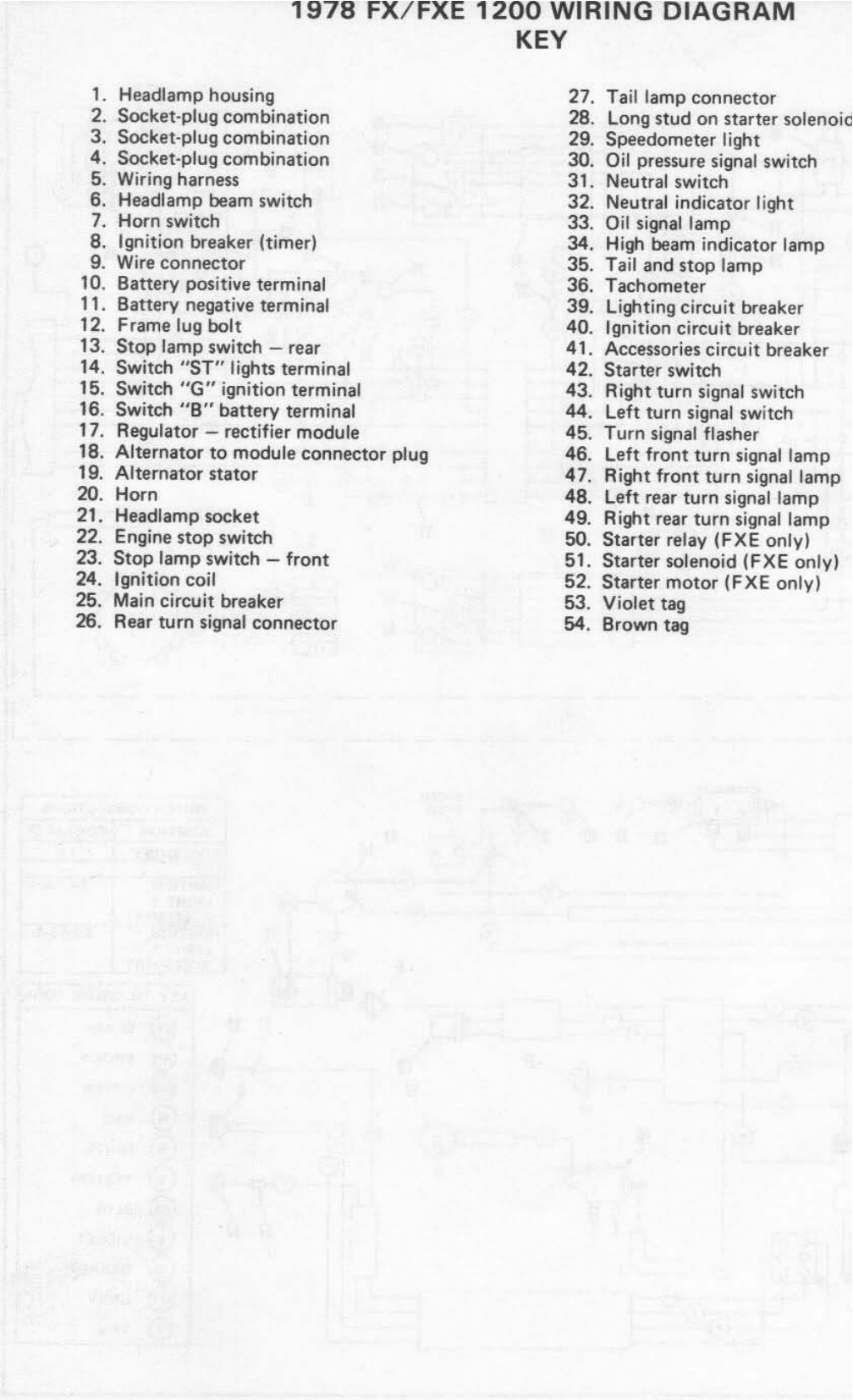

Figure 5-1K. 1978 FL/FLH 1200 Wiring Diagram

1978 FX/FXE 1200 WIRING DIAGRAM KEY

- 
1. Headlamp housing
 2. Socket-plug combination
 3. Socket-plug combination
 4. Socket-plug combination
 5. Wiring harness
 6. Headlamp beam switch
 7. Horn switch
 8. Ignition breaker (timer)
 9. Wire connector
 10. Battery positive terminal
 11. Battery negative terminal
 12. Frame lug bolt
 13. Stop lamp switch – rear
 14. Switch “ST” lights terminal
 15. Switch “G” ignition terminal
 16. Switch “B” battery terminal
 17. Regulator – rectifier module
 18. Alternator to module connector plug
 19. Alternator stator
 20. Horn
 21. Headlamp socket
 22. Engine stop switch
 23. Stop lamp switch – front
 24. Ignition coil
 25. Main circuit breaker
 26. Rear turn signal connector
 27. Tail lamp connector
 28. Long stud on starter solenoid
 29. Speedometer light
 30. Oil pressure signal switch
 31. Neutral switch
 32. Neutral indicator light
 33. Oil signal lamp
 34. High beam indicator lamp
 35. Tail and stop lamp
 36. Tachometer
 39. Lighting circuit breaker
 40. Ignition circuit breaker
 41. Accessories circuit breaker
 42. Starter switch
 43. Right turn signal switch
 44. Left turn signal switch
 45. Turn signal flasher
 46. Left front turn signal lamp
 47. Right front turn signal lamp
 48. Left rear turn signal lamp
 49. Right rear turn signal lamp
 50. Starter relay (FXE only)
 51. Starter solenoid (FXE only)
 52. Starter motor (FXE only)
 53. Violet tag
 54. Brown tag

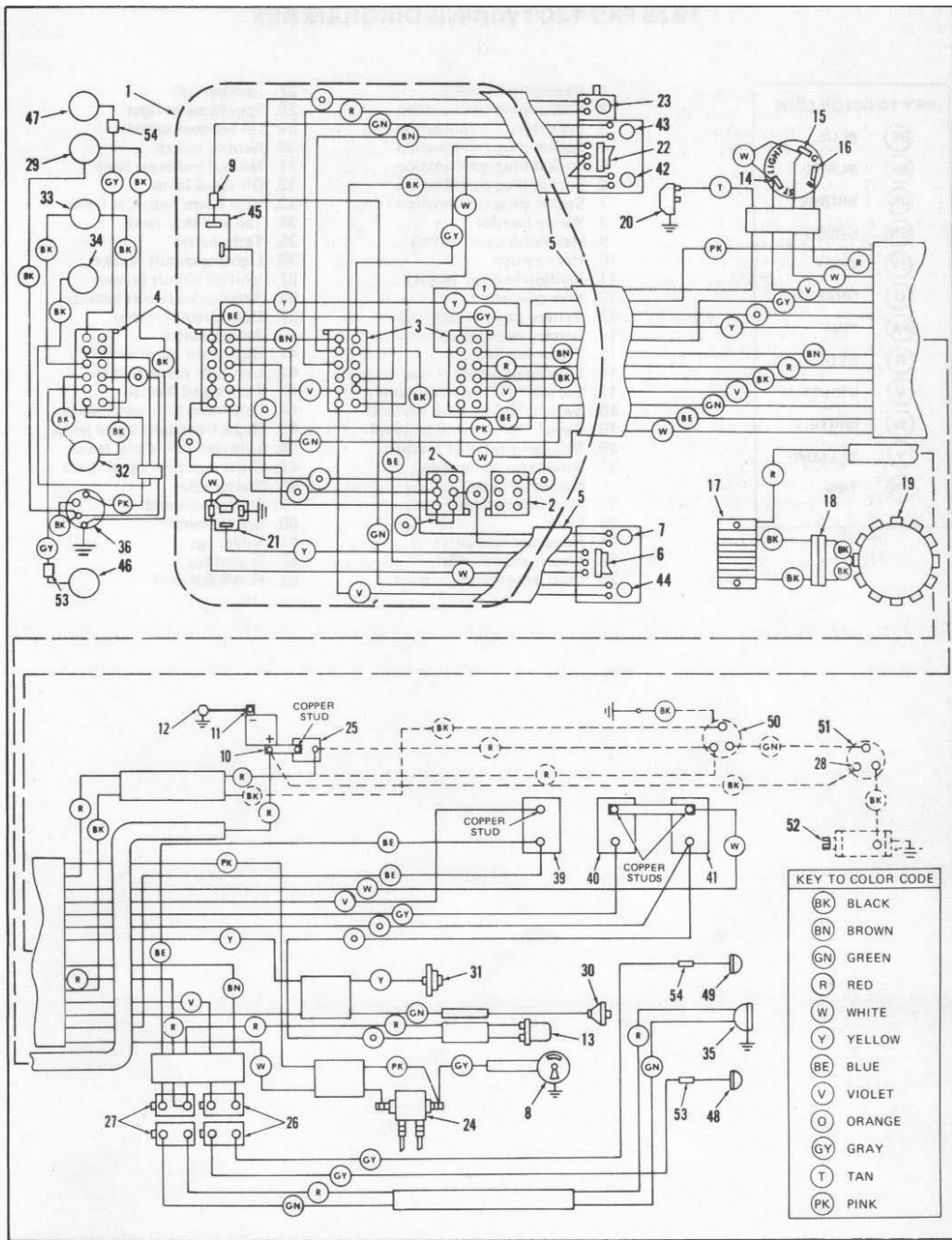

Figure 5-1L. 1978 FX/FXE 1200 Wiring Diagram

1978 FXS 1200 WIRING DIAGRAM KEY

KEY TO COLOR CODE

(BE)	BLUE
(BK)	BLACK
(BN)	BROWN
(GN)	GREEN
(GY)	GRAY
(O)	ORANGE
(PK)	PINK
(R)	RED
(V)	VIOLET
(W)	WHITE
(Y)	YELLOW
(TN)	TAN

- | | |
|--|----------------------------------|
| 1. Headlamp housing | 27. Ignition coil |
| 2. Socket-plug combination | 28. Speedometer light |
| 3. Socket-plug combination | 29. Oil pressure switch |
| 4. Socket-plug combination | 30. Neutral switch |
| 5. Socket-plug combination | 31. Neutral indicator lamp |
| 6. Socket-plug combination | 32. Oil signal lamp |
| 7. Socket-plug combination | 33. High beam indicator lamp |
| 8. Wiring harness | 34. Tail and stop lamp |
| 9. Headlamp beam switch | 35. Tachometer |
| 10. Horn switch | 36. Lighting circuit breaker |
| 11. Ignition breaker (timer) | 37. Ignition circuit breaker |
| 12. Wire connector | 38. Accessories circuit breaker |
| 13. Battery positive terminal | 39. Main circuit breaker |
| 14. Battery negative terminal | 40. Starter switch |
| 15. Frame lug bolt | 41. Right turn signal switch |
| 16. Stop lamp switch – rear | 42. Left turn signal switch |
| 17. Switch "ST" lights terminal | 43. Turn signal flasher |
| 18. Switch "G" ignition terminal | 44. Left front turn signal lamp |
| 19. Switch "B" battery terminal | 45. Right front turn signal lamp |
| 20. Regulator-rectifier module | 46. Left rear turn signal lamp |
| 21. Alternator to module
connector plug | 47. Right rear turn signal lamp |
| 22. Alternator stator | 48. Starter relay |
| 23. Horn | 49. Starter solenoid |
| 24. Headlamp socket | 50. Starter motor |
| 25. Engine stop switch | 51. Violet tag |
| 26. Stop lamp switch – front | 52. Brown tag |
| | 53. Handlebar bolt |

SWITCHES

IGNITION-LIGHT SWITCH

GENERAL

FL

The ignition-light switch is located on the instrument panel. Lift lock cover and use the key to lock or unlock. It is not necessary to keep the key inserted in the lock to operate this switch after it has been unlocked. The center position of the switch is the "OFF" position for both lights and ignition. The left (counterclockwise) of center position is for accessories only. There are two positions to the right (clockwise) of center position. For U.S.A. operation, both positions operate ignition and lights, with standard wiring. The switch can be locked only in the "OFF" and "ACCESSORIES" positions. The FL ignition switch may be disassembled for repair.

FX

The ignition-light switch is located below the gas tank on left side of motorcycle. From the "OFF" vertical position there are two positions to the right for ignition and lights. For U.S.A. operation, both positions operate ignition and lights, with standard wiring. Key can only be removed in the "OFF," locked position. The FX ignition switch is not repairable. It must be replaced if it is defective.

FXS

The ignition switch is located at the rear of the oil tank, under the seat on the left side of the motorcycle. Operation is identical to the FX models.

DISASSEMBLING IGNITION LIGHT SWITCH

Remove instrument panel cover by prying out side cover clip located at trip mileage set knob and turning out mounting base center screw located in the center of instrument panel below speedometer.

Disconnect all wires connected to switch terminals and remove four switch mounting screws.

See Figure 5-2. All directions for disassembly apply with switch in an inverted position. Switch must be in "OFF" position and unlocked.

Grasp end of roller contact retainer with pliers and simultaneously move it upward and away from roller contact (1). Lift off roller contact and switch mounting plate assembly (2). Notice that this plate is positioned with the three terminal side away from lock cover hinge.

Reinforcing plate (3) with contact bar holder (4) and roller contact retainer (5) can be removed from switch cover by slipping part assembly sideways until one set of tabs clears slot in switch cover, then lifting and sliding assembly the opposite direction to clear other tab.

Switch base (7) and lock plate (6) can be removed from switch cover. Note that narrow end of elongated hole in lock, and lug on switch lock (8) which fits into hole in lock plate, are toward lock cover hinge.

Lock assembly (8) can now be lifted out of switch cover (9). Avoid separating switch cylinder from its case unless lock is faulty. On some models the lock cylinder and case are a single unit.

CLEANING, INSPECTION AND REPAIR

Wash all parts in cleaning solvent and dry with compressed air.

Inspect all parts, particularly roller contact and plate assembly for excessive wear of contacting brass buttons and roller surfaces. Extreme wear of these parts may allow head of roller contact retainer to short against switch lock plate. Loosened terminals on switch mounting plates may also cause a short or an inconsistent positive contact. Replace all worn or rusted parts.

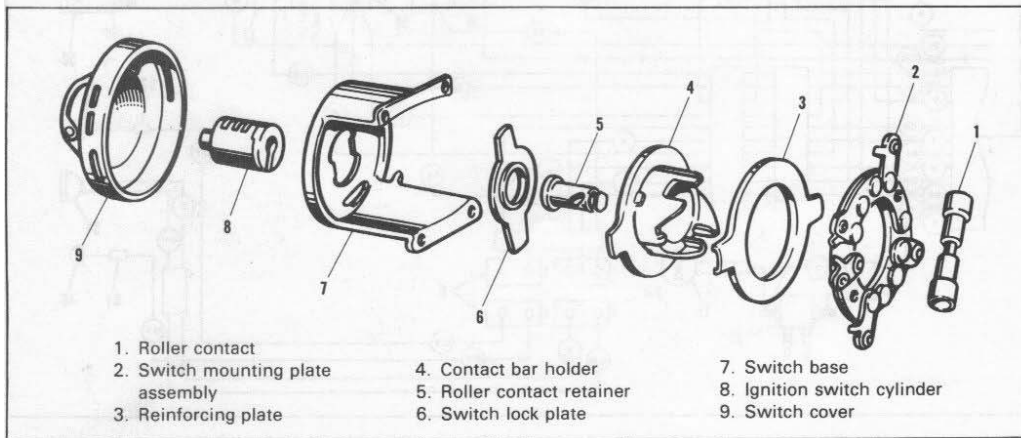

Figure 5-2. Ignition Light Switch

ASSEMBLING IGNITION LIGHT SWITCH

Apply a light coat of grease to head of roller contact retainer, lock plate, roller contact and contact buttons on switch mounting plate.

Assemble parts in reverse order of disassembly. If lock cylinder had to be removed from case for repair or replacement, it must be replaced in correct position or switch cannot be locked. To reassemble correctly, insert lock cylinder into housing with tumblers in any one of the four registers. While pressing cylinder into housing with fingertip, insert key and turn clockwise as far as possible. Remove key and complete assembly.

HANDLEBAR SWITCH - 1970 AND 1971

This type switch is used for momentary closing of circuits to horn, or starting motor and is located on handlebar. Terminal has either one or two wires. See Figure 5-2A.

DISASSEMBLING

To disassemble the switch, remove screws (1) from housing. Pull remaining parts from housing as an assembly.

REPLACING

1. To replace the switch wires, unsolder or cut wires from contacts. The wire ends should have about 1/4 inch of insulation stripped off.

2. Lead one wire through cup, lower contact, plastic washer and spring to upper contact. Be sure parts are arranged as shown. Insert one wire end through center of upper contact, spread strands out flat over contact and solder. Lead second wire through cup and solder to lower contact.

3. Insert button and assembled parts in housing and reinstall switch on handlebar.

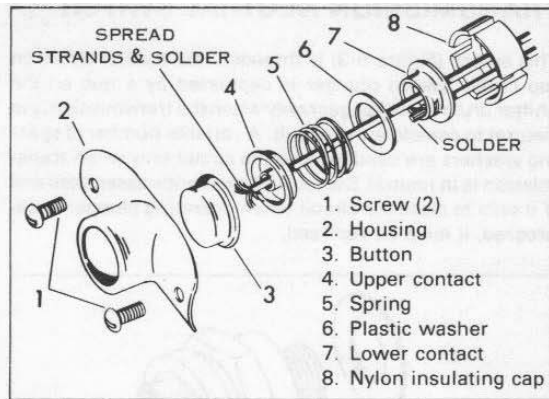

Figure 5-2A. Button Switch - Exploded View

HANDLEBAR SWITCH - 1972 AND LATER

The left handlebar switch assembly, Figure 5-2B, contains a rocker arm switch (headlamp HI-LO beam) and two pushbutton switches (horn and left turn signal). The right handlebar switch assembly contains a rocker arm switch (RUN-OFF) and two pushbutton switches (engine start and right turn signal). Individual rocker arm and pushbutton switches can be replaced if defective.

To replace individual switches, remove four screws (1, Figure 5-2B) and pull off cover (2) assemblies. Remove screws (3) and rocker switches (4) and (5) or screws (6), retainer (7) and pushbutton switch (8) as needed. Reassembly is the reverse of disassembly.

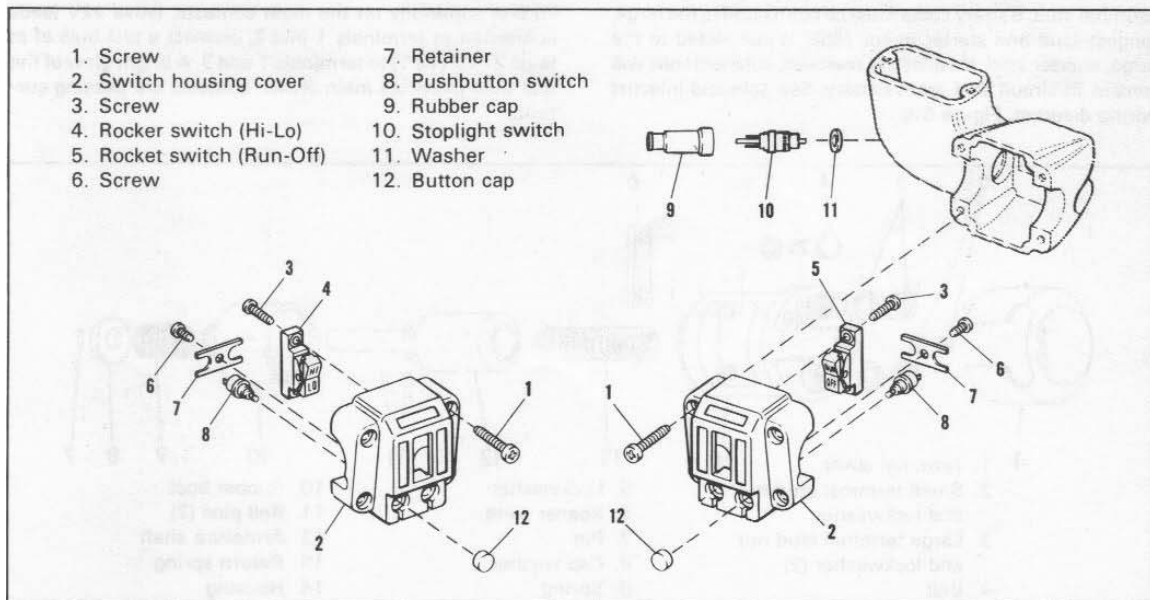

Figure 5-2B. Handlebar Switch Assemblies

TRANSMISSION NEUTRAL SWITCH

This switch (Figure 5-3) is threaded into the transmission top cover. Switch plunger is depressed by a nub on the shifter drum or shifter gear only when the transmission is in neutral to complete the circuit. A variable number of spacing washers are used to close the circuit only when transmission is in neutral. Switch is permanently assembled and if it fails to close the circuit when operating plunger is depressed, it must be replaced.

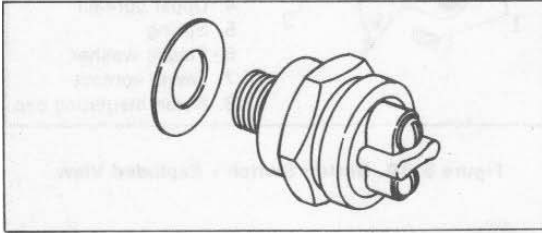

Figure 5-3. Neutral Switch

SOLENOID SWITCH

Solenoid switches are designed to close and open electrical circuits electro-magnetically. Switches of this type consist basically of contacts and a winding around a hollow cylinder containing a movable plunger. When the winding is energized by the battery through an external control circuit, the magnetism produced pulls the plunger into the coil. The contact disc attached to the plunger moves against two main switch contacts closing the circuit.

The solenoid switch individual parts are replaceable as shown in exploded view, Figure 5-4. The control circuit wire from handlebar starter button is connected to small terminal stud. Battery cable must be connected to the large, longest stud and starter motor cable is connected to the large, shorter stud. If cables are reversed, solenoid coils will remain in circuit and drain battery. See solenoid internal wiring diagram, Figure 5-6.

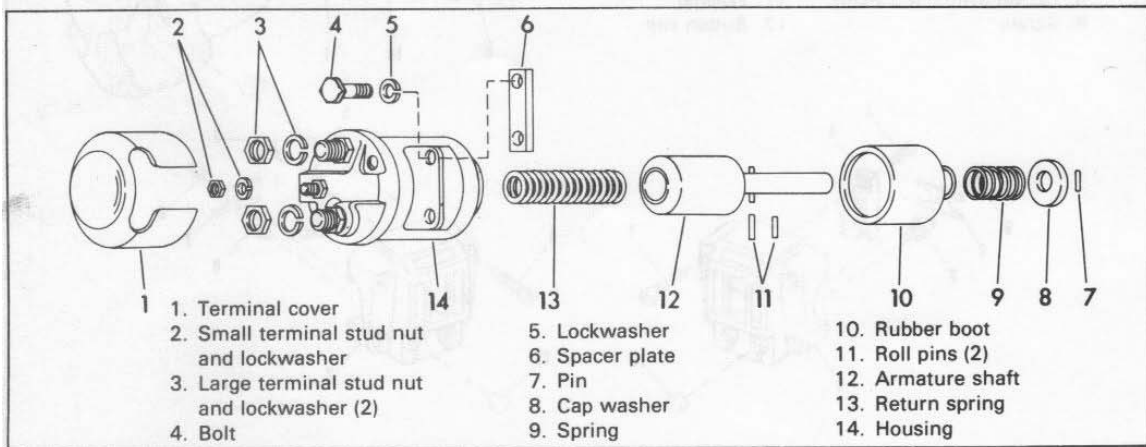

Figure 5-4. Solenoid Switch - Exploded View

TESTING SOLENOID SWITCHES

When it is suspected that a solenoid switch is defective, tests should be made of the solenoid coil winding and continuity through the main switch when contacts are in closed position. Using the test circuit described, these two tests can be made simultaneously.

With solenoid disconnected from control circuit, battery and motor, make test circuit connections as follows: (See Figure 5-5).

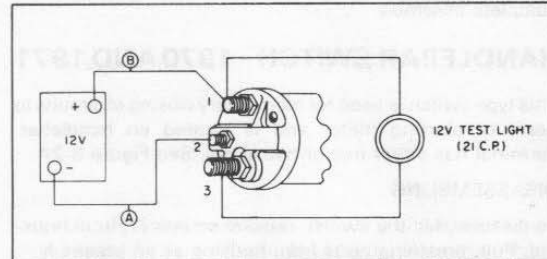

Figure 5-5. Test Circuit for Solenoid

Since solenoid coil requires 12V to actuate plunger closing main switch contacts, use a 12-volt battery. Leads A and B are connected to terminals 1 and 2 (coil terminals) to actuate solenoid. A sharp click should be heard from the solenoid switch when making this connection. No click or a heavy spark at the terminals when connecting wires would indicate either an open or short in the solenoid winding and solenoid switch must be replaced. If the solenoid winding checks good and plunger does close main switch contacts, there is still a possibility contacts are badly burned or eroded and will not pass heavy current. (See Figure 5-6).

To test continuity on the main contacts, leave 12V leads connected to terminals 1 and 2, connect a test bulb of at least 21 CP (12 V) to terminals 1 and 3. A bright glow of the test bulb indicates main switch contacts are passing current.

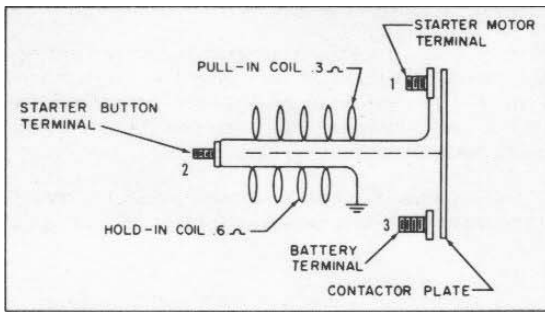

Figure 5-6. Solenoid Internal Wiring Diagram

STARTER RELAY SWITCH

Figure 5-7 shows a test circuit using a 12-volt battery and stop lamp bulb. Contacts should close and bulb should light when connection is made at positive post of battery and should go out when connection is broken.

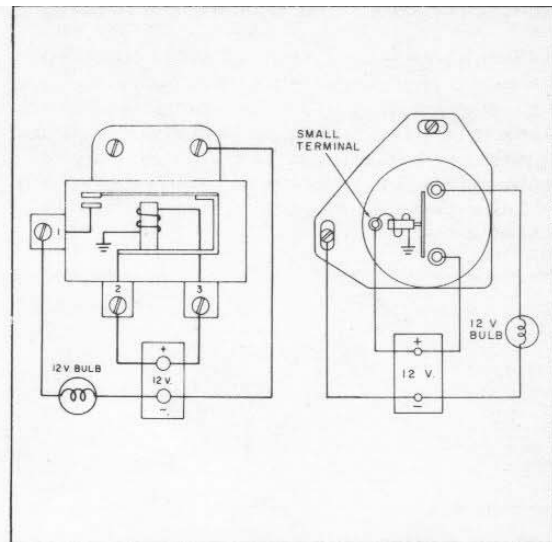

Figure 5-7. Starter Relay Internal Wiring Diagram and Test Circuit

STOP LAMP FRONT BRAKE SWITCH

This is a mechanical, normally-closed plunger type switch which closes the stoplight circuit when the front brake hand lever is operated. Repair parts for the switch are not available; it must be replaced as a unit.

STOP LAMP REAR BRAKE SWITCH

This is a hydraulic, normally-open switch, which is located in the rear hydraulic brake line, and closes the circuit when the rear brake is applied.

LAMPS

HEADLAMP

The headlamp is a sealed beam type, specially designed and made for Harley-Davidson motorcycles. When replacement is required, use only the prescribed sealed beam unit. Do not attempt to use an automobile sealed beam unit because the current requirements for a motorcycle are much less than for an automobile and damage to battery or generator will result. If either filament burns out, or the lens breaks, the entire unit must be replaced.

REPLACING HEADLAMP

1. Loosen door screw enough to remove headlamp door. Remove three retaining ring screws and retaining ring.
2. The sealed beam unit is now free from the headlamp body, and connector block can be removed from the unit by pulling connector block from the unit prongs.
3. Assembly is the reverse order of disassembly. Make sure connector block contacts are clean to ensure good electrical contact.

ADJUSTING BEAM

To get the greatest efficiency from the headlamp and to meet the requirements of the law, correctly adjust headlamp beam according to the following instructions.

Draw a horizontal line on a wall or screen exactly the same height as the center of the headlamp to be checked and adjusted. Then, position the motorcycle on a level surface with headlamp approximately 25 feet away from the test pattern. Have a rider sit on the motorcycle to simulate actual running conditions. Be sure tires are correctly inflated. Aim the headlamp directly at the screen and turn on the light switch. Set beam selector switch on the high beam position, and check beam for height and direction. The top of the main beam of light should register even with, but no higher than the horizontal line.

The lamp can be tilted up or down to aim it in relation to the horizontal line by turning vertical adjusting screw in or out. The lamp can be aimed to the right or left in relation to the front wheel by turning the horizontal adjustment screw in or out.

BULB CHART

Lamp Description	Bulbs Rqd.	Candle Power or Wattage	Harley-Davidson Part Number
		12V.	12V.
HEADLAMP	1		67717-64
Hi Beam		50 Watts	
Lo Beam		45 Watts	
TAIL AND STOP LAMP	1		68165-64
Tail Lamp		4 C.P.	
Stop Lamp		32 C.P.	
INSTRUMENT PANEL			
Oil Pressure Signal Light	1	2 C.P.	68462-64
Speedometer Light	1		71090-64
Generator Signal Light (Special Radio)	1		
Neutral Indicator Light	1	2 C.P.	68462-64
High Beam Indicator	1	2 C.P.	68462-64
ACCESSORIES			
Spot Lamp (Bulb Type)	1	32 C.P.	68715-64
Spot Lamp (Sealed Beam Type)	1	30 Watts	68726-64
Parking Lamp	-	3 C.P.	68166-64
Turn Indicator Lamps	4	32 C.P.	68572-64A
Turn Indicator Pilot Lamps	2	1.5 C.P.	71090-64

CHARGING SYSTEM (1975 & EARLIER)

ALTERNATOR

GENERAL

The synchro alternator consists of two main components: the rotor (magnetic field) which is mounted on the engine sprocket shaft, and the stator (armature) which is bolted to the engine crankcase.

ROTOR

The rotor is circular in shape with an outer flange that extends over the stator. On the inside of the flange there are twelve (12) pole shoes which are ceramic magnets having a steel inner face and form a field ring of alternate north and south poles, six (6) of each.

STATOR

The stator consists of twelve (12) coils, each wound over a laminated iron core. The coils are positioned radially around the engine crankshaft and bolted to the outside of the engine crankcase.

There are two series windings on the stator, an output winding and a regulator winding. The output winding consists of several strands of wire in parallel, wound around each core, forming a continuous circuit from coil to coil. The regulator winding consists of a single strand of the same size wire also wound continuously around each core from coil to coil, but wound in the reverse direction. The output winding has a center tap which permits full wave rectification in the rectifier-regulator unit, called a module.

RECTIFIER-REGULATOR

GENERAL

The rectifier-regulator module consists of two basic circuits, a rectifying circuit which converts alternating current to direct current and a regulating circuit which controls the voltage output of the alternator. The components of the rectifier-regulator are encapsulated in a rubberized plastic material to form a permanent module. A temperature compensator, which is located in a wiring harness end not encapsulated with the rectifier-regulator components, increases the voltage output of the alternator during colder weather.

OPERATION (Figure 5-8)

When a magnetic pole in the rotor passes over the end of a laminated core in the stator, a current is induced in the stator coils. This current passes through terminal BE and isolation diode (3). When the rotor movement brings the next magnetic pole, which has an opposite polarity, over the laminated core of the coil, the current within the coil reverses in direction. This action occurs simultaneously in all twelve coils, with six (6) coils having current induced in one direction and the remaining six (6) in the other direction. As the twelve (12) sets of rotor magnets move to the next set of stator coils, the current in all the stator coils reverses.

Current flow into the rectifier-regulator module can only enter through isolation diode (3). Rectifier diodes (1) and (2) prevent reverse current from entering the rectifier-regulator diode. Since terminal (BE) is center tapped to each coil, there will be current flow into the rectifier-regulator during each current reversal (half cycle). This results in a full wave rectification of the single phase AC output of the stator.

The center tap alternator-to-rectifier arrangement prevents damage to the alternator system in the event of incorrect battery or booster battery connection. One half of the output producing winding is in series with each diode. Isolation diode (3) isolates the stator from the battery in the event of a stator coil ground or rectifier short and also improves dead battery recharge capability.

The voltage control (regulator) circuit consists of a silicon controlled rectifier (SCR) (4), capacitor (5), resistor (6), thermistor (7) and zener diodes (8) and (9). When the system voltage across A and B exceeds the rated values (approximately 14 volts) of the zener diodes (8) and (9), the zener diodes conduct and apply a voltage to the control element of SCR (4). When the voltage reaches a predetermined value, the SCR (4) allows a proportionate flow of current through the alternator regulating windings to ground at terminal B. An increase of current flow in the alternator regulator windings opposes the current flow in the stator output windings and the power from the output windings is decreased. Conversely, a decrease in system voltage across A and B below the rated values of the zener diodes (8) and (9) would produce an increase in power from the stator output windings. In this manner, the voltage regulator senses the system voltage across the battery and supplies the necessary regulating current for limiting it to a predetermined value.

The thermistor (7) is a temperature compensating resistor which controls the operating point of the zener diode (8) so that a higher system voltage is produced when needed in cold weather and a lower system voltage in hot weather.

Capacitor (5) serves to suppress transient voltages in the system.

PRECAUTIONS to be exercised with alternator charging system.

1. **DO NOT** reverse battery connections. This is for a negative ground system only.
2. Connect booster batteries properly: positive to positive and negative to negative.
3. **DO NOT** polarize the alternator.
4. **DO NOT** ground any wires from stator or modules which terminate at connectors.
5. **DO NOT** operate engine with battery disconnected from system.
6. Disconnect negative battery lead if battery charger is used to charge battery.

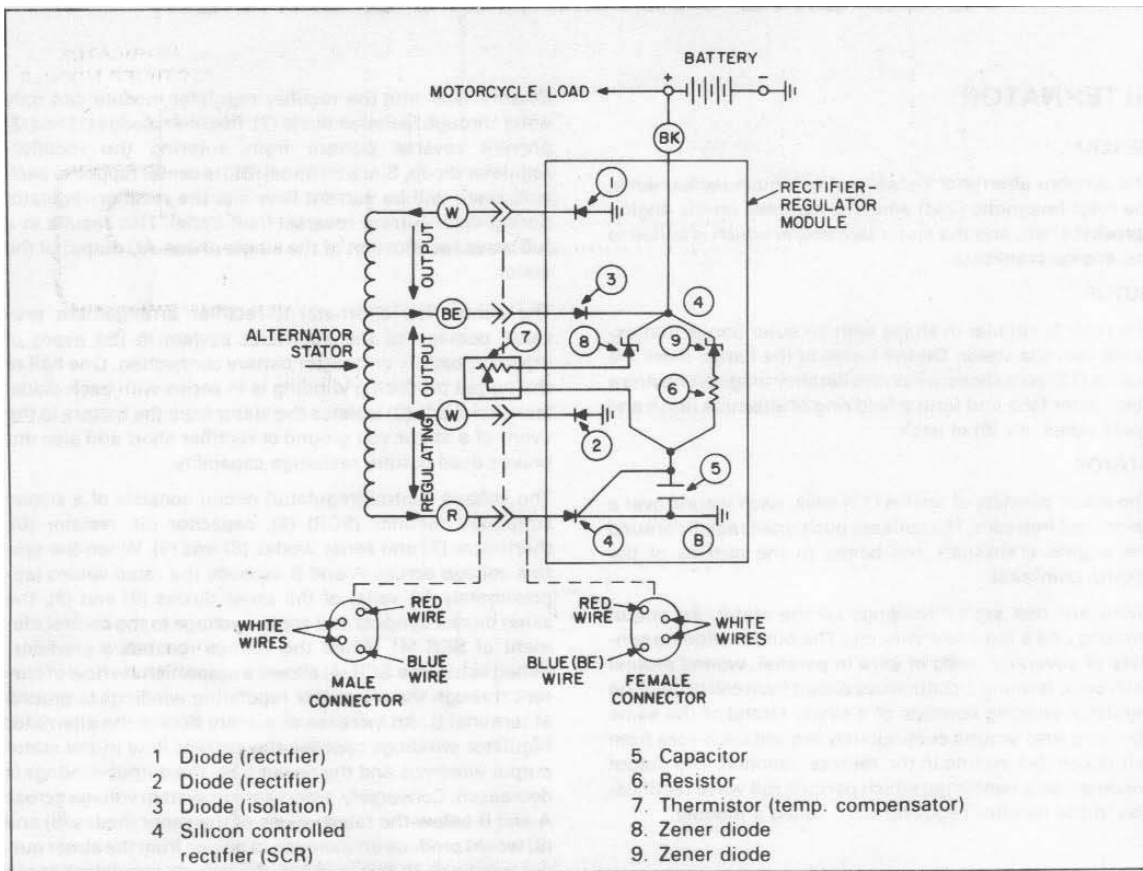

Figure 5-8. Charging System - Schematic Diagram

7 Never use a fast battery charger to boost the battery output to start engine

8 The connector used at crankcase prevents incorrect wiring from the stator to the rectifier and regulator module. To prevent damage to module, DO NOT CONNECT OR DISCONNECT PLUG WHILE ENGINE IS RUNNING

9 The rectifier and regulator modules are grounded to the engine and therefore should not be removed and mounted at some remote location. This is a negative ground circuit. Be sure battery is grounded properly to frame and engine.

CHECKING CHARGING SYSTEM

GENERAL

When the charging system fails or is not charging at a satisfactory rate, as is visually evidenced by a weak battery and dim lights, it is recommended that the following checks be made.

PRELIMINARY CHECKS

Battery: Check for weak or bad battery. See Battery Section. Battery must be fully charged for following electrical tests.

Wiring: Check for corroded or loose connections in charging circuit. Regulator module base must have a good, clean, tight connection to engine crankcase for proper grounding.

ELECTRICAL CHECKS

If the preliminary inspection shows components to be in good condition, make the following electrical checks: (See Figures 5-9 and 5-10.)

1. **Regulating Voltage Check:** Connect an ammeter in series with the alternator output (blue wire terminal at battery). Connect load rheostat (carbon pile) and voltmeter across battery. Check regulating voltage while running engine at 3600 rpm.

Turn load rheostat (or carbon pile) to off position. With engine and module stabilized at operating temperature voltage reading should be between 13.8 and 15.0 volts at 3.5 amperes output with 75° air temperature measured near the regulator thermistor (in wire).

NOTE

Voltage will vary with air temperature as shown in curve and should be within limits shown for any temperature. (See Figure 5-12.)

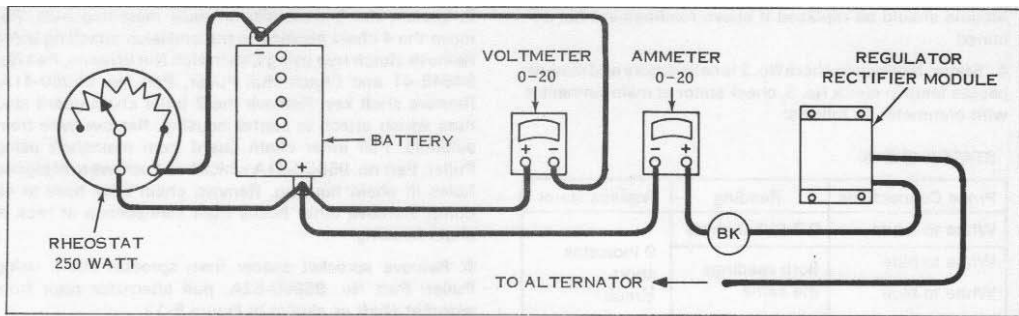

Figure 5-9. Test Arrangement with Individual Components

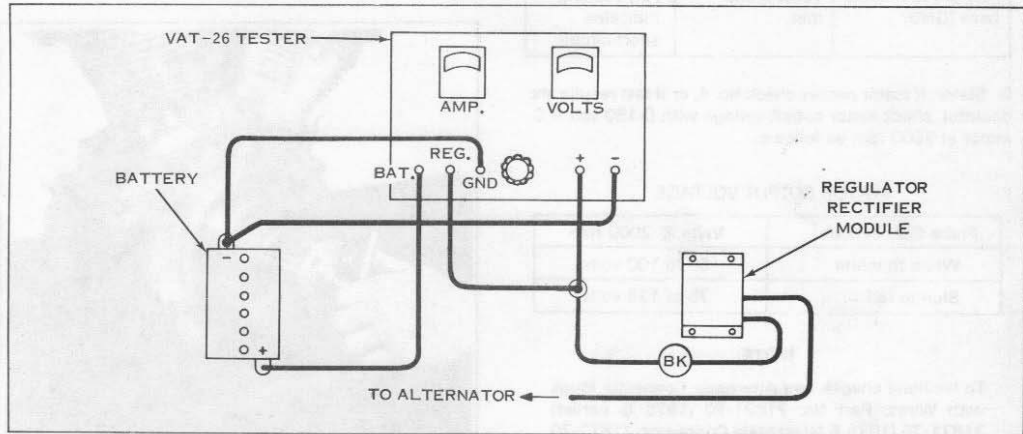

Figure 5-10. Test Arrangement with Sun Vat-26 Tester

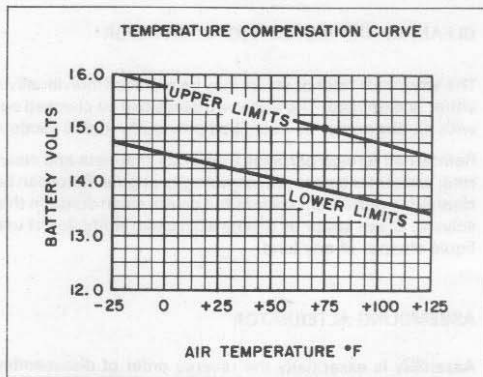

Figure 5-11. Regulating Voltage

2. Output Check: Run engine at 2000 rpm and adjust load rheostat (carbon pile) to obtain a constant 13.0 volts. The alternator output current should be 10.5 amperes minimum. If check is unsatisfactory proceed to check No. 3.

3. If output in check No. 2 is unsatisfactory, check module as follows: Remove module plug from stator plug. With ohmmeter or 12 volt test lamp and battery, check circuits at female connector as follows:

MODULE CHECK

Probe Connections	Reading			
	+ Polarity		- Polarity	
	Light	Ohm-meter	Light	Ohm-meter
White to module base (GND)	Off	Infinity	On	3 to 15
White to module base (GND)	Off	Infinity	On	3 to 15
Blue to black	On	3 to 15	Off	Infinity
Red to module base (GND)	Off	Infinity	Off	Infinity

Module should be replaced if above readings are not obtained.

4. Stator: If output in check No. 2 is satisfactory and module passes tests in check No. 3, check stator at male connector with ohmmeter as follows:

STATOR CHECK

Probe Connections	Reading	Replace Stator
White to white	0.3 to 1.0 ohms	0 indicates short circuit
White to blue White to blue	Both readings the same	
Blue to red	1.5 to 2.0 ohms	
Any pin to module base (GND)	100K ohms min.	Any reading indicates short circuit

5. Stator: If stator passes check No. 4, or if test results are doubtful, check stator output voltage with 0-150 volt A.C. meter at 2000 rpm as follows:

STATOR OUTPUT VOLTAGE

Probe Connections	Volts @ 2000 rpm
White to white	50 to 100 volts
Blue to red	75 to 125 volts

NOTE

To facilitate checks, use Alternator Connector Plugs with Wires, Part No. 71871-70 (1975 & earlier) 71871-75 (1976 & later) Male Connector, 71872-70 (1975 & earlier) or 71872-75 (1976 & later) Female Connector.

DISASSEMBLING ALTERNATOR

1. Remove left footrest and chain housing cover. If motor-cycle is equipped with compensating sprocket, use Compensating Sprocket Shaft Nut Wrench, Part No. 94557-55, to remove compensating sprocket shaft nut. If not equipped with compensating sprocket, use 1-3/8 in. socket or box wrench to remove nut. Loosen nut by striking wrench handle several sharp blows with hammer.
2. Remove chain adjuster mounting bolt and large brass starter shaft thrust washer.
3. Remove push rod adjusting screw locknut (nut on center screw on clutch sprocket), slip washer (any metal washer about 1-3/4 in. in diameter with 3/8 in. hole) over push rod adjusting screw and replace locknut. Remove three spring tension adjusting nuts and pull clutch outer disc and spring collar assembly off clutch drive hub pins. Move clutch sprocket and motor sprocket out and remove from shafts with chain.
4. Remove three bolts, attaching chain housing at engine sprocket shaft.

5. Loosen the 5 transmission base mounting nuts. Remove the 4 chain housing to transmission attaching bolts. Remove clutch hub using Clutch Hub Nut Wrench, Part No. 94645-41 and Clutch Hub Puller, Part No. 95960-41A. Remove shaft key. Remove the 2 inner chain guard stud nuts which attach to starter housing. Remove wire from solenoid. Pull inner chain guard from mainshaft using Puller, Part no. 95960-41A which has 4 screws to fit tapped holes in chain housing. Remove chain oiler hose at oil pump. Remove other hoses from connections at back of chain housing.

6. Remove sprocket spacer from sprocket shaft. Using Puller, Part No. 95960-52A, pull alternator rotor from sprocket shaft as shown in Figure 5-12.

7. Remove 4 screws securing stator to crankcase. Disconnect wire plug and remove stator from engine.

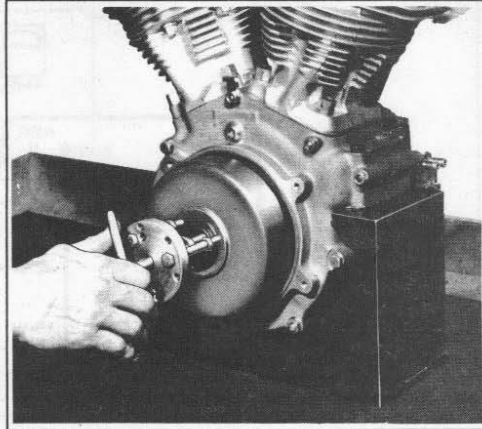

Figure 5-12. Pulling Alternator Rotor

CLEANING AND INSPECTING ALTERNATOR

The alternator rotor or stator may be replaced individually if either is damaged. The stator windings can be checked out with an ohmmeter as described previously in this section.

Remove all foreign particles from rotor magnets and clean rotor and stator before reassembling to engine. Rotor can be cleaned in petroleum solvent but do not clean stator in this solvent. Clean stator by wiping with clean cloth; do not use liquid cleaner of any kind.

ASSEMBLING ALTERNATOR

Assembly is essentially the reverse order of disassembly except for the following differences:

After assembling stator to crankcase and tightening 4 screws to 30-40 in-lbs torque, use Tool, Part No. 97225-55, to press rotor onto sprocket shaft so that it bottoms tightly against seal spacer. See Figure 5-13.

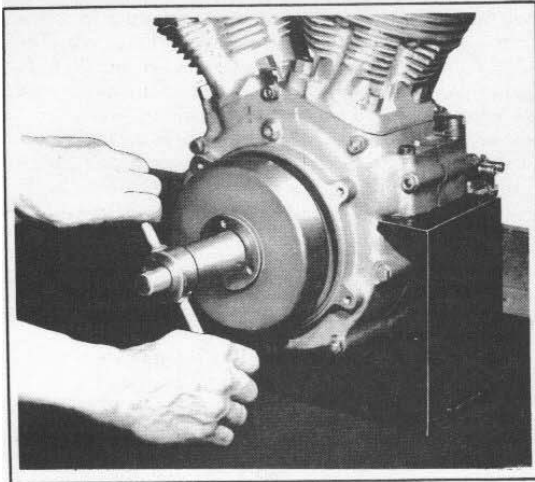

Figure 5-13. Installing Alternator Rotor

Harley-Davidson "Stud and Bearing Mount," Part No. 99626-77, should be applied to transmission shaft ball bearing recess in chain housing and on shaft. Pack ball race with grease after housing is tapped in place. Apply

aluminum paint to joining surface of chain housing and transmission. Use new chain housing O-ring in groove of engine crankcase, also use new cover gasket when reassembling.

NOTE

Leave transmission base mounting nuts loose until engine and transmission are secured to chain housing.

NOTE

Engine sprocket is aligned with clutch sprocket by a selection of spacers between sprocket and crankcase bearing. Reinstall same thickness of spacers as was removed, or determine correct spacer size as given in Section 2.

IMPORTANT

After assembly, chain housing must be air tight. Vacuum in chain housing can be checked with Vacuum Gauge, Part No. 96950-68 and should be 20 in. of water or more at 1500 rpm with hose to vent tee closed off. A lower reading than this indicates an air leak into chain housing at gasket, solenoid, starter shaft or hoses.

CHARGING SYSTEM (1976 & LATER)

ALTERNATOR

GENERAL

The alternator consists of two main components: the rotor (magnetic field) which is mounted on the engine sprocket shaft, and the stator (armature) which is bolted to the engine crankcase. See Figure 5-8.

ROTOR

The rotor is circular in shape with an outer flange that extends over the stator. On the inside of the flange there are twelve (12) magnets in a plastic ring.

STATOR

The stator consists of twelve (12) coils, each wound over a laminated iron core. The coils are positioned radially around the engine crankshaft and bolted to the outside of the engine crankcase. See Figure 5-8.

The stator has a single output winding.

NOTE

The 1975 & earlier and 1976 & later individual components (rotor, stator and rectifier-regulator) are not directly interchangeable.

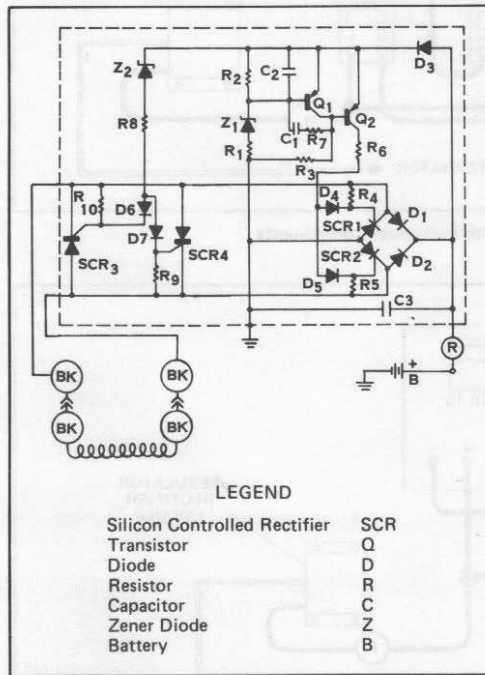

LEGEND

Silicon Controlled Rectifier	SCR
Transistor	Q
Diode	D
Resistor	R
Capacitor	C
Zener Diode	Z
Battery	B

Figure 5-14. Tympanium Rectifier-Regulator - Schematic Diagram

TYMPANIUM RECTIFIER-REGULATOR

GENERAL

The rectifier-regulator manufactured by Tympanium is a series regulator with a shunt control. The circuit combines the functions of rectifying and regulating. Figure 5-14 shows the schematic diagram.

The circuit essentially is a full wave bridge made up of two SCR's and two diodes - SCR1, SCR2, D1 and D2.

Each SCR has a control gate which turns it "on" or "off" (makes it conduct or not conduct). When the alternator voltage is too high, both SCR's turn "off," the current paths are blocked, and the battery is not charged. When the voltage lowers to an acceptable level, the opposite happens and the battery is charged.

The rectifier-regulator has a set, predetermined "on-off" voltage built into it. This value is determined by Z1, R1 and R2. These components are factory adjusted so that when the voltage gets above 14.5 volts nominal, the SCR's are turned off.

The battery voltage is sensed through D3, R2, Z1, and R1. When the voltage at the point between Z1 and R2 exceeds 14.5 volts, it turns Q1 "on" which, in turn, turns Q2 "off." Thus, Q1 and Q2 form a flip-flop circuit where when one is "on" the other is "off" and vice versa. With Q2 "off," the current can not flow to the gates. This means the bridge essentially has been opened and there is no current flow to charge the battery.

As soon as the voltage gets below 14.5 volts at the point between Z1 and R1 the opposite happens. Q1 turns "off," Q2 turns "on," current flows to the gates, the bridge is closed and there is current flow to charge the battery.

In summary, the active elements of the regulating circuit are: Q1, Q2, SCR1 and SCR2. The elements of the sensing circuit are D3, R2, Z1 and R1.

One of the advantages of a series regulator is that there is automatic reverse polarity protection. If the battery is connected backward in a normal bridge, there will be a dead short. Not so in this circuit, because the SCR's simply can not be turned on.

To prevent high voltage build up, shunting SCR3 and SCR4 have been added. These SCR's simply short out the alternator winding when the voltage gets too high. The shunt regulator voltage setting is 40 to 50 volts. When this voltage is reached, current flows through zener diode Z2 and resistor R8 which turns "on" the shunt SCR's. Turned "on," the output is directly shorted.

CHECKING CHARGING SYSTEM

GENERAL

When the charging system fails or is not charging at a satisfactory rate, as is visually evidenced by a weak battery and dim lights, it is recommended that the following checks be made.

PRELIMINARY CHECKS

Battery: Check for weak or bad battery. See Battery Section. Battery must be fully charged for following electrical tests.

Wiring: Check for corroded or loose connections in charging circuit. Rectifier-regulator base must have a good, clean, tight connection for proper grounding.

ELECTRICAL CHECKS

If the preliminary inspection shows components to be in good condition, make the following electrical checks:

Regulating Voltage Check: (See Figures 5-15 and 5-16.) Connect an ammeter in series with the alternator output. Connect load rheostat (carbon pile) and voltmeter across battery. Check regulating voltage while running engine at 3600 rpm.

Adjust load rheostat (or carbon pile) to 3.5 amperes output. The voltage readings then should conform to the values given by the curves shown in Figure 5-17 at the temperature measured at the time of testing. For example, if the air temperature was +75°F, the upper voltage (from upper curve) would be 15.0 volts and the lower voltage (from lower curve) would be 13.8 volts.

Output Check: Run engine at 2000 rpm and adjust load rheostat (carbon pile) to obtain a constant 13.0 volts. The alternator output current should be 14 amperes minimum.

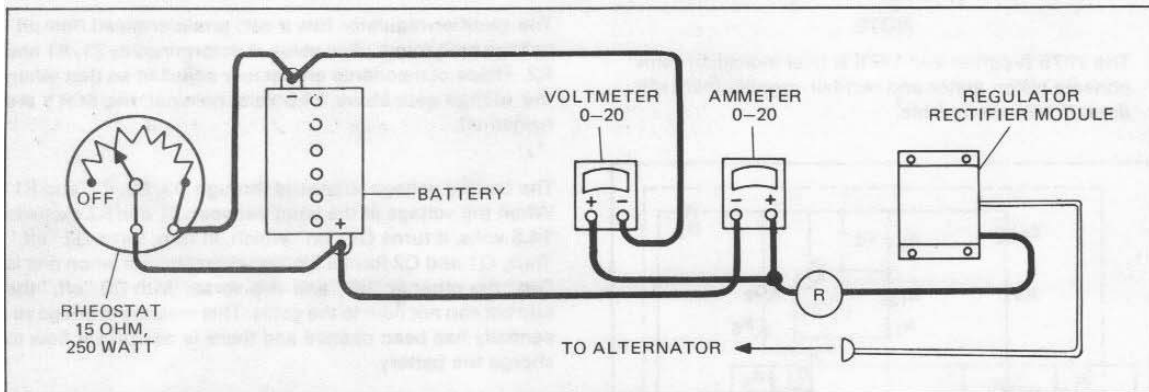

Figure 5-15. Test Arrangement with Individual Components

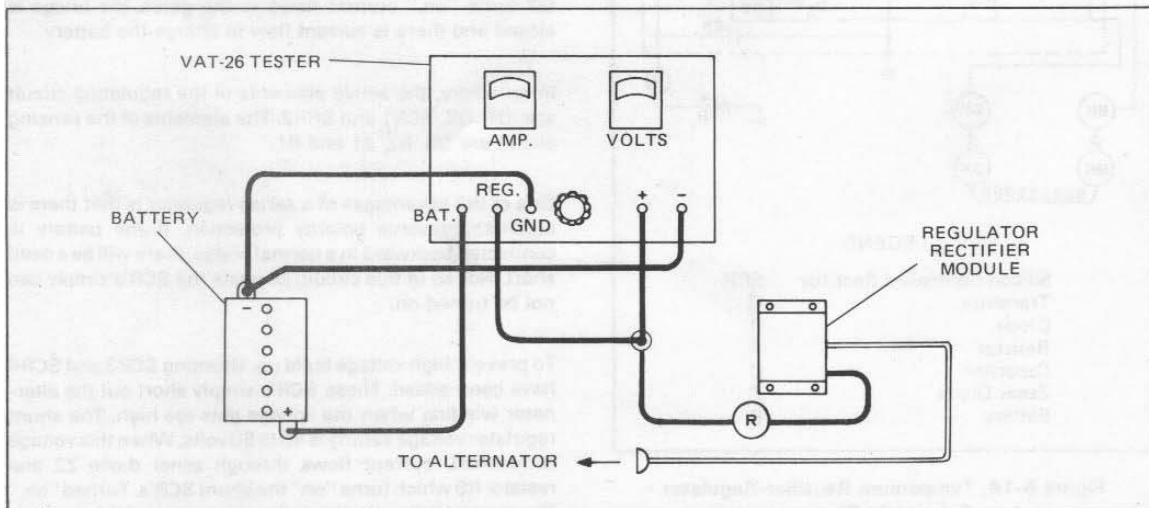

Figure 5-16. Test Arrangement with Sun Vat-26 Tester

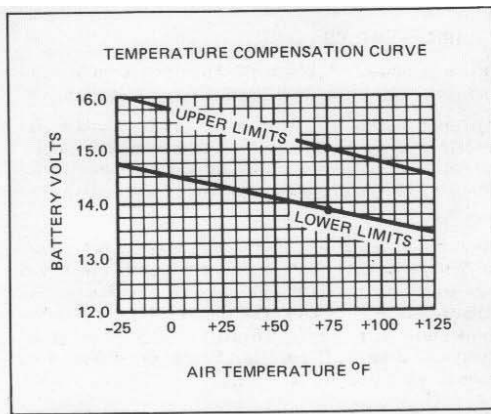

Figure 5-17. Regulating Voltage

Check Stator and Rotor:

Make resistance checks. The coil resistance should check 0.2 to 0.4 (very low) across the contacts of the plug with an accurate ohmmeter. If found to be either open or shorted, the unit is defective. Also using an ohmmeter, check each pin to ground. There should be no continuity to ground (open circuit) as indicated by a reading of 1/2 megohm minimum.

Check AC output voltage with an AC voltmeter. It should be 19 to 26 volts per 1000 rpm. If there are shorted turns, the voltage will be reduced.

If the above checks are unsatisfactory, stator and rotor should be disassembled and checked for physical damage. As a final check, substitute components known to be good and check again. If the substituted units perform okay, the original units probably were defective.

Check the Rectifier-Regulator:

If the rectifier-regulator appears to be the defective component, check it by replacing it with a unit that is known to be good and check again. Electrically disconnect the unit to be checked, then temporarily connect in the new unit. If the output is now okay, the original rectifier-regulator was defective and should be replaced. If the output is still unsatisfactory, the original unit was probably okay and the problem lies elsewhere.

DISASSEMBLING, CLEANING AND INSPECTING, AND ASSEMBLING ALTERNATOR

This alternator is taken apart, checked, and put back together in basically the same way as the previous 1975 and earlier units, with the following exception: stator plastic magnet ring must be pushed back into stator before re-mounting and must be flush or below the outside rim of the shell.

CIRCUIT BREAKER

DESCRIPTION

The ignition system has two circuits, the primary circuit and the secondary circuit. The primary circuit consists of the battery, switch, primary coil, breaker points, condenser and associated wiring. The secondary circuit consists of the secondary coil, the spark plugs and associated wiring.

The circuit breaker is located on the gearcase cover on the right hand side of the motorcycle. It has two functions. First, the breaker cam and contact points open and close the low voltage circuit between the battery and ignition coil causing the coil to produce high voltage discharge to the spark plugs. Second, the circuit breaker times discharge for proper engine firing.

The breaker points are operated by a cam with two lobes. The narrow lobe times the front cylinder and the wide lobe times the rear cylinder. A single ignition coil fires both spark plugs at the same time, but one spark occurs in the exhaust stroke of one cylinder and the other spark fires the combustible gases in the other cylinder to produce the power stroke.

The advance mechanism is an extension on the camshaft and operates at half crankshaft speed. The spark timing cam is advanced automatically as engine speed increases and retarded as speed decreases through action of the flyweights in the circuit breaker base. This ensures correct spark timing to suit starting, low and high speed requirements.

OPERATION

In tracing the current through the ignition system the initial current comes from the battery. The current flows from the battery through the primary coil to ground and back to the battery while the points are closed. When the cam opens the points, the circuit is broken so that a high voltage surge is produced from ignition coil primary to secondary. This voltage will cause a spark to jump the air gap of the spark plugs.

The condenser is connected to the circuit breaker points and functions to produce a quick collapse of the magnetic field in the coil so that high voltage will be produced. In doing this, the condenser acts to prevent current from continuing to flow across the contact points after points open.

The engine must be timed to fire at the proper point before top dead center on the compression stroke of each cylinder. This procedure is covered under subsequent headings.

TROUBLESHOOTING

Disengage spark plug cable and insert a metal rod, screw or nail into each spark plug cable. Arrange cable end so tip of inserted metal object is 1/4 in. away from cylinder head. Turn on the ignition, break the points by hand. See if a "hot" or "blue" spark is obtained. If not, it is an indication of a weak coil, dead battery, broken or loose wires, etc. Arcing of the points and hard starting indicates a faulty condenser.

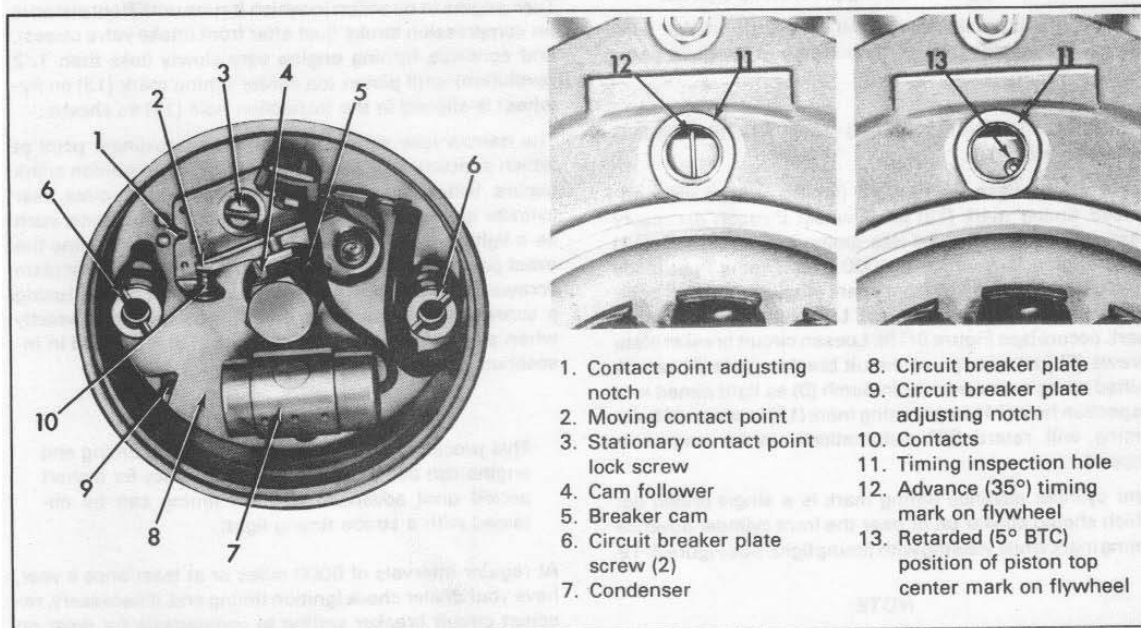

Figure 5-18. Circuit Breaker and Timing Gears

ADJUSTING POINTS (Figure 5-18)

Circuit breaker points should be checked for gap and contact surface condition initially at 500 and 1000 miles, and thereafter every 2000 miles. Remove spark plugs to permit engine to turn easily and rotate flywheels so that cam follower (4) is on one of the highest points of wide cam lobe (5). Check the gap between the contacts (10) with a .018 in. gauge (wire preferred). If it is not exactly .018 in. when the cam follower (4) is on highest point of wide cam lobe (5), adjustment is necessary. Incorrect point gap spacing affects ignition timing. To adjust the points, loosen the lock screw (3) and move stationary contact plate, using screwdriver in adjusting notch (1) to provide correct contact point gap. Retighten the lock screw (3) and again check the gap to make sure it remains correct. Points in pitted or worn condition should be replaced.

IMPORTANT

Point gap should be the same for both small and large cam lobes. If variation exceeds .004 in., it is an indication that the cam is running eccentric and the condition should be corrected. See "Assembling."

CHECKING AND ADJUSTING IGNITION TIMING

Ignition timing is controlled by the circuit breaker. Correct ignition timing and correct setting of the circuit breaker contact point gap is absolutely necessary for proper engine operation and performance.

The spark timing cam is advanced automatically as engine speed increases through action of the flyweights in the circuit breaker base. This ensures correct spark timing to suit starting, low speed and high speed requirements.

To check or reset ignition timing proceed as follows:

Remove circuit breaker cover and set circuit breaker contact gap at exactly .018 in. as outlined in previous paragraph.

CHECKING ADVANCED TIMING WITH STROBE TIMING LIGHT (Figure 5-18)

Use a strobe flash timing light (timing gun) to view advanced timing mark (12) on flywheel through accessory plastic view plug screwed into timing inspection hole (11) while engine is running at 2000 rpm. Timing light leads should be connected to front spark plug, ground and positive red wire to battery terminal. Light will flash each time spark occurs (see Figure 5-19). Loosen circuit breaker plate screws (6) just enough so circuit breaker plate (8) can be shifted using a screwdriver in notch (9) as light aimed into inspection hole (11) stops timing mark (12) in center of hole. Timing will retard 30° automatically when engine is stopped.

Rear cylinder advance timing mark is a single drilled dot which should appear on or near the front cylinder advance timing mark while viewing with timing light. See Figure 5-19.

NOTE

Retard mark (smaller drilled dot) should not move into timing hole at idle speed.

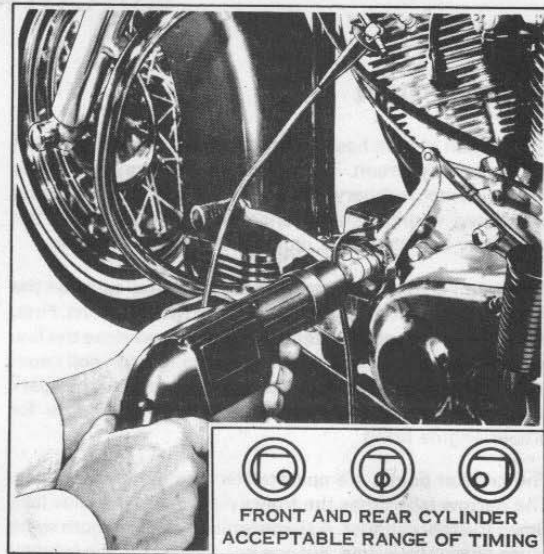

Figure 5-19. Checking Timing with Strobe Light

CHECKING RETARDED TIMING WITH CIRCUIT TESTER (Figure 5-18)

If a strobe timing light is not available, approximate timing can be obtained in an emergency, by using the following procedure:

Remove screw plug from timing inspection hole (11) in left side of crankcase. Then remove front push rod cover so that opening and closing of valve can be observed.

Turn engine in direction in which it runs until front piston is on compression stroke (just after front intake valve closes), and continue turning engine very slowly (less than 1/2 revolution) until piston top center timing mark (13) on flywheel is aligned in the inspection hole (11) as shown.

The narrow lobe cam is now at the approximate point at which contacts (10) open and front cylinder ignition spark occurs. When the wide cam lobe opens the points, rear cylinder ignition spark occurs. Connect a circuit tester such as a light bulb across the contact points to determine the exact point of contact opening. Loosen circuit breaker plate screws (6) just enough to shift circuit breaker plate (8) using a screwdriver in notch (9), so contacts will open exactly when piston top center timing mark (13) is aligned in inspection hole (11) as shown in Figure 5-18.

IMPORTANT

This procedure will result in approximate timing and engine can be operated in an emergency for a short period until advanced position timing can be obtained with a strobe timing light.

At regular intervals of 5000 miles or at least once a year, have your dealer check ignition timing and, if necessary, re-adjust circuit breaker setting to compensate for wear on circuit breaker that may have caused a slight change in timing.

DISASSEMBLING CIRCUIT BREAKER PARTS
(Figure 5-20)

Remove circuit breaker cover screws (1), cover (2) and gasket (3). Pull wire terminal (4) from breaker contact assembly (12) terminal post. Remove circuit breaker cam bolt (5). Remove breaker plate screws (6, 6A or 6B) and lockwashers and washers or retainer (7A), to free breaker plate assembly (8).

Remove cam (9) from advance assembly (10) and remove advance assembly from gearcase cover.

To remove circuit breaker contact assembly (12) from circuit breaker plate (13), pull condenser (15), terminal from breaker contact terminal post. Also unhook flat spring from terminal post. Remove screw (11) to free point set from breaker plate (13). To remove condenser (15), remove screw and lockwasher (14) from breaker plate (13).

To disassemble advance mechanism, unhook spring (16) loops from grooves in pivot pins and slip flyweights (17) with spring from pivot pins on advance base (18). Do not remove springs from flyweights unless they are to be replaced. Roll pins (18, 19 and 20) are pressed in and can be replaced if necessary.

INSPECTING AND REPLACING PARTS
(Figure 5-20)

Using cloth with clean white gasoline, wipe circuit breaker clean and inspect parts.

Inspect circuit breaker contacts (12). If lever rubbing block is badly worn, replace. Contacts that are burned or pitted should be replaced or dressed with a clean, fine-cut contact point file. Do not attempt to remove all roughness nor dress contacts surfaces down smooth; merely remove scale or dirt. Contact point file should not be used on other metal and should not be allowed to become greasy or dirty. Never use emery cloth or sandpaper to clean contacts since particles will embed themselves and cause arcing and rapid burning.

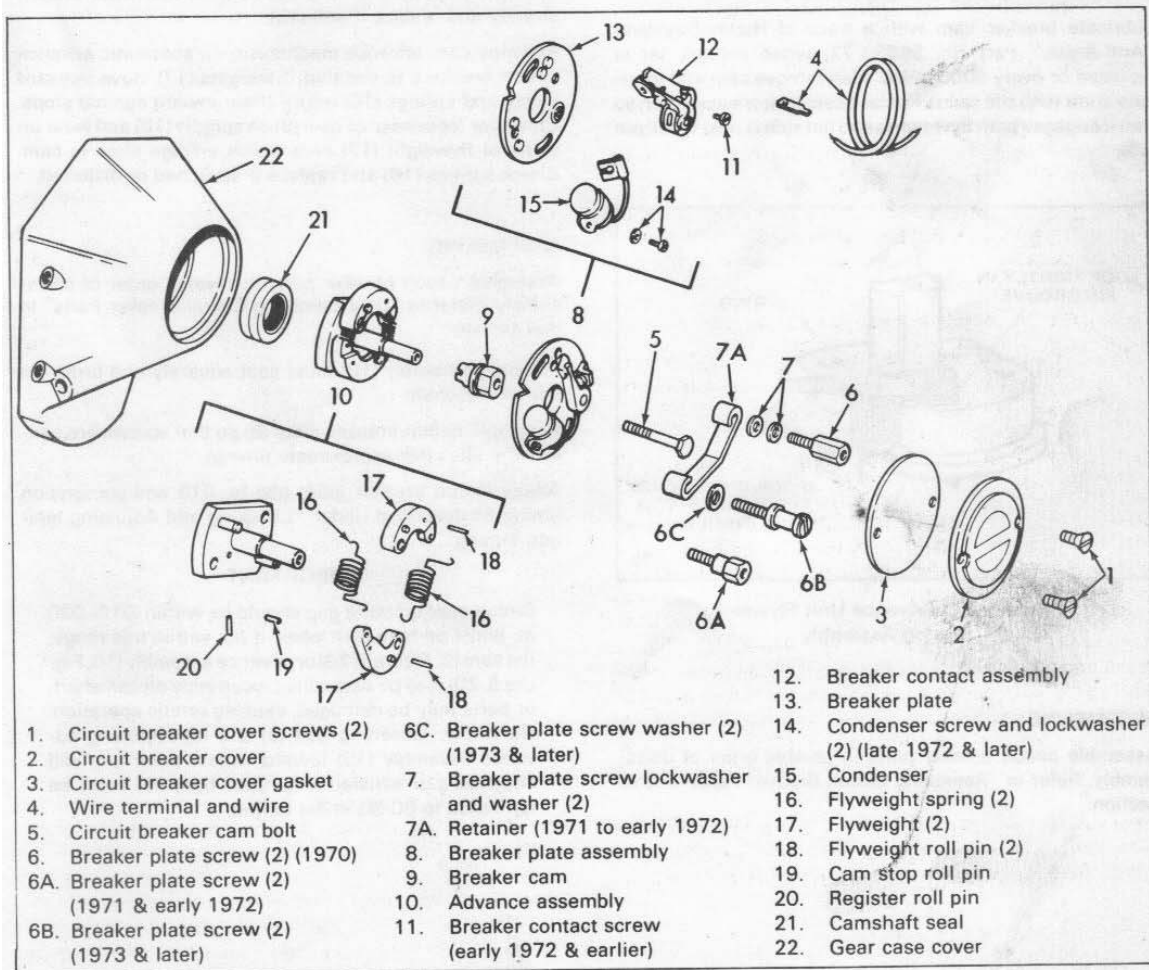

Figure 5-20. Circuit Breaker - Exploded View

Circuit breaker contact assembly (12) should be replaced, if contact point pressure is not within prescribed limits of 14 to 18 oz. Check pressure with a spring gauge. The scale should be hooked to the breaker lever at an angle of 90 degrees with the point surface and reading taken just as contacts break. Excessive pressure causes rapid wear of rubbing block, cam and contacts. Insufficient pressure will permit high speed bounce which will, in turn, cause arcing and burning of the contacts and missing of the engine.

Contact faces must seat squarely against each other. If bent, square up by bending plate on levers.

Inspect lip of cam seal (21) and replace it if worn or rough. Also replace seal if there is evidence of oil leakage into circuit breaker arm.

When installing contacts, be sure contact faces seat squarely against each other. Adjust gap as previously described in "Adjusting Circuit Breaker Points."

Check flyweight springs, and if bent or stretched, replace them. When installing, be sure that bent end of each spring is hooked through bottom of hole, and that upper looped end grips groove in pin tightly. See Figure 5-21.

Lubricate breaker cam with a trace of Harley-Davidson "Anti-Seize," Part No. 96632-77, when contact set is replaced or every 5000 miles. Also remove cam and lubricate shaft with the same. Replace cam in correct position so that it engages both flyweights and flat side is next to roll pin (19).

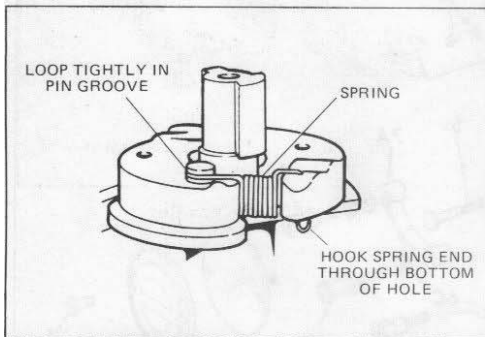

Figure 5-21. Advance Unit Flyweight Spring Assembly

ASSEMBLING

Assemble circuit breaker parts in reverse order of disassembly. Refer to "Removing Circuit Breaker Parts" in this section.

Check circuit breaker advance flyweight action by moving cam in direction required to advance weights to their fully extended position. Then release the cam and see if springs return to the fully retarded position. Correct causes for faulty action by cleaning and lubricating shaft, cam and flyweights with "Anti-Seize" and replacing weak springs.

Be extremely careful to avoid excessive lubrication. If too much is used, the excess is apt to get on the circuit breaker contacts and cause them to burn. For maximum operating efficiency it is recommended practice to replace circuit breaker contacts when pitted, burned or worn excessively.

The condenser (15) is a relatively long life part and will not require frequent replacement. However, if the condenser is suspected of being defective simply replace with a proven new condenser and note whether engine performance is improved. A condenser that is defective will have either an open or short circuit. An open circuit will be evident by excessive arcing at breaker contacts and a shorted circuit will have no noticeable spark at the contacts.

Examine the coil to circuit breaker low tension wire (4, Figure 5-20) for brittle or cracked insulation and broken strands and replace if defective.

Examine cam advance mechanism on automatic advance circuit breakers to see that flyweights (17) move outward freely and springs (16) return them inward against stops. Check for looseness of cam (9) on spindle (10) and wear on sides of flyweight (17) ears which engage slots in cam. Check springs (16) and replace if stretched or distorted.

ASSEMBLING

Assemble circuit breaker parts in reverse order of disassembly. Refer to "Disassembling Circuit Breaker Parts" in this section.

Advance assembly (10) must seat squarely and firmly on end of camshaft.

Assemble circuit breaker plate (8) so that screws are centered in slots (for approximate timing).

Adjust circuit breaker point gap to .018 and set ignition timing as described under "Checking and Adjusting Ignition Timing."

IMPORTANT

Circuit breaker point gap should be within .016-.020 in. limits on both cam lobes. If not within this range, the cam (9, Figure 5-20) or advance assembly (10, Figure 5-20) may be assembled incorrectly on camshaft, or parts may be damaged, causing erratic operation. Generally, loosening bolt (5) and repositioning advance assembly (10) toward widest point gap will equalize gap satisfactorily. Cam bolts (5) must be tightened to 60-80 in-lbs torque.

IGNITION COIL

DESCRIPTION

The ignition coil is a pulse transformer that transforms or steps up low battery or generator voltage to high voltage necessary to jump the electrode at the spark plug in the engine cylinder head. Internally, coil consists of primary and secondary windings with laminated iron core and sealed in waterproof insulating compound. Case cannot be taken apart or coil repaired. If the ignition coil is defective it must be replaced.

TROUBLESHOOTING

NOTE

Interpret references to "plug," "cable," "condenser," etc., and "plugs," "cables," "condensers" when more than one are used.

When hard starting or missing indicates a faulty ignition system, first, check condition of source of current (battery or magneto depending on model of motorcycle). If lamps light with full brilliancy and horn blows, indicating current source is in at least fair condition check, clean or replace spark plug. If this does not correct performance, inspect circuit breaker points and install new condenser. If condition persists, check primary and secondary resistance of ignition coil with an ohmmeter. Resistances should be within following limits: Primary resistance 4.7 to 5.7 ohms, secondary resistance 16,000 to 20,000 ohms (16K to 20K).

If an ohmmeter is not available to test coil, temporarily substitute a new ignition coil by attaching it at any convenient point near old coil (coil will function without being securely grounded). Transfer terminal wires to new coil according to the information given in the wiring diagrams pertaining to the model being worked on. Attach new coil cable to the spark plug. If ignition trouble is eliminated by the temporary

installation of new coil, carefully inspect old coil for damaged cables and installation. The insulation on cables (and on some models the coil itself) may be cracked or otherwise damaged allowing high tension current to short to metal parts. This is most noticeable in wet weather or when motorcycle has been washed.

Replacing plug cable is the only repair that can be made to an ignition coil. If this does not correct faulty coil performance, coil is defective.

REPLACING SPARK PLUG CABLE (Figure 5-22)

Remove old cable (1) from coil terminal and install new cable. Always be certain that cable boot or cap (2) is securely tightened to the coil tower to prevent moisture and dirt from contacting the high tension lead. Replace boot or cap if damaged or loose fitting.

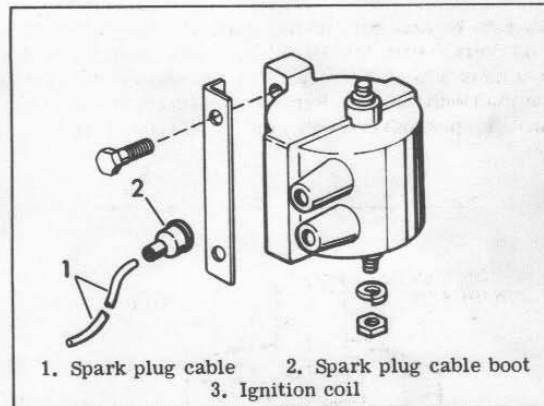

Figure 5-22. Ignition Coil

SPARK PLUGS

GENERAL

Harley-Davidson spark plugs (Figure 5-23) have been designed to give maximum life and efficient combustion of fuel. They are available in various "heat ranges," each for a particular service application. Plugs are labeled with numbers, the lowest number indicating the "hottest" plug. Designations such as 3-4 and 3-5 are special purpose plugs.

For normal service, the spark plug as recommended in motorcycle "Specifications," should be used on a particular model. However, for special service conditions, a "colder" or "hotter" plug may be desired. The number 3 plug could be used for slow speed or short run operation while the number 4 plug could be used for the higher speeds of highway travel or maximum throttle operation. It is not uncommon for best results to be obtained with plugs of different heat ranges in front and rear cylinders, with the front usually the colder.

The 5R6 plug has a resistor element to reduce radio interference originating in the motorcycle ignition system. The resistor element will not affect engine performance or fuel economy.

Inspect spark plugs for condition and electrode gap every 2000 miles.

Spark plugs may be replaced or cleaned at the 2000 mile inspection depending upon the condition of the porcelain and electrodes, however, a new plug will provide the best performance. The spark plugs should be replaced with new ones at least every 5000 miles.

REMOVING SPARK PLUGS

Disconnect wires from plugs, connection is simple snap-on type. Use a deep socket wrench or special spark plug wrench to loosen plugs. Blow away all dirt from plug base with compressed air before removing plug.

CAUTION — Do not pull on spark plug wires since this may damage internal conductor causing high resistance and reduction in firing voltage.

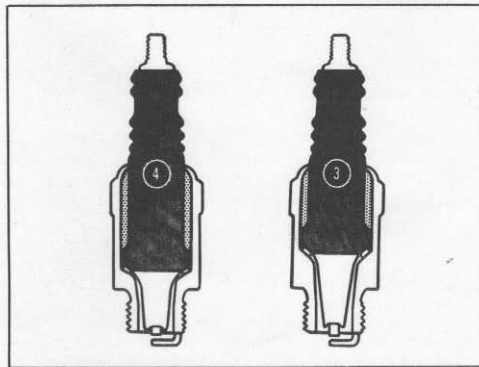

Figure 5-23. Spark Plug Heat Range

CLEANING, INSPECTION AND REPAIR (Figure 5-24)

Examine plugs as soon as they have been removed. The deposits on the plug base are an indication of the correctness of the plug heat range and efficiency, as well as a guide to the general condition of rings, valves, carburetor and ignition system.

A wet, black and shiny deposit on plug base, electrodes and ceramic insulator tip (A) indicates an oil fouled plug. The condition is caused by worn rings and pistons, loose valves, weak battery, faulty ignition wires, circuit breaker trouble, weak coil or a cold plug.

A dry, fluffy or sooty black deposit (B) indicates plug is gas fouling, a result of a too rich carburetor air-fuel mixture, long periods of engine idling or a cold plug.

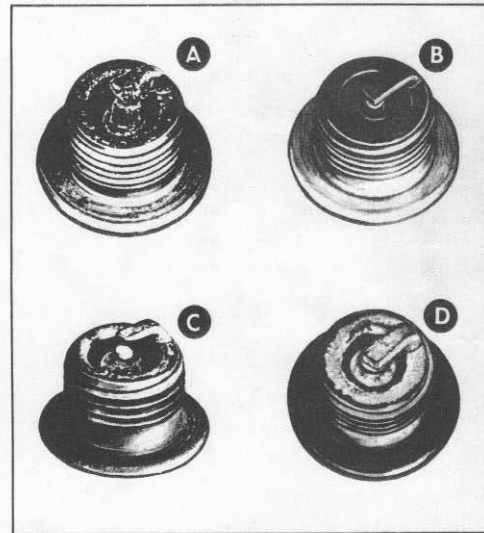

Figure 5-24. Type of Plug Base Deposits

An overheated plug (C) can be identified by a light brown, dry, glassy looking deposit. This condition may be accompanied by cracks in the insulator tip and is caused by too lean an air-fuel mixture, a hot running engine, valves not seating, improper ignition timing or too hot a plug for the service. The oxide deposit on the spark plug is a conductor when hot. It will cause plug to misfire, especially at high speed.

A plug with a rusty brown to tan powdery deposit (D) indicates a balanced ignition and combustion condition. With leaded gasolines the deposits may be white or yellow. In either case, ignition functions through the deposits if only light and the deposits should be cleaned off at regular intervals to keep them from building up.

When spark plug electrodes have become eroded away (C) to the point where gap setting is difficult or impossible, the plug should be replaced. Plugs with cracked insulator should also be discarded.

Clean plugs with a sand blast cleaner. Rotate plug top while applying sand blast to clean insulator and electrodes. Cleaning time should be carefully limited to just what is necessary to clean deposits from insulator nose. Prolonged use of abrasive blast will wear away insulator. Normally three to five seconds of sand blasting is sufficient. Never use metal instruments to remove deposits from plugs.

SETTING SPARK GAP

Before setting spark gap on used plugs, pass a thin point file (or nail file) between electrodes to produce flat, parallel surfaces to facilitate accurate gauging.

Use only a wire type gauge. Bend the outside or grounded electrode so only a slight drag on the gauge is felt when passing it between electrodes. Never make adjustments by bending the center electrode. Set gap on all plugs as shown under "Engine Specifications."

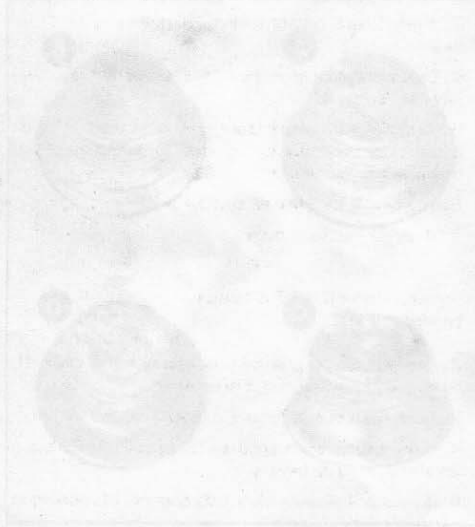

TESTING SPARK PLUGS

Check the sparking ability of a cleaned and regapped plug on a sparking comparator if possible. An inability to withstand rapid firing under cylinder compression conditions can be discovered.

INSTALLING SPARK PLUGS

Before turning spark plugs into cylinder heads, check condition of threads in head and on plug. Soften deposits in cylinder head with penetrating oil and clean out with tap or old plug.

Install new spark plug gasket and turn plug down finger tight. Tighten to 15 ft-lbs in aluminum head, or 20 ft-lbs in cast iron head, with torque wrench or 3/4 of a turn.

Check and adjust engine idle speed and mixture setting after installing new set of plugs if necessary.

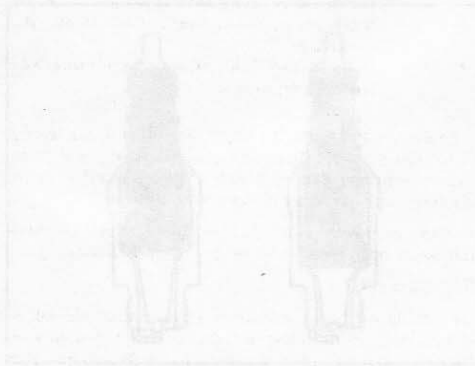

BATTERY

GENERAL

The battery serves as a storage place for current used in starting the motorcycle, to operate accessories when the engine is not running and to provide additional current, when necessary, over the amount being generated. For a battery to remain in good condition, the current draw must be balanced by a current input. All Harley-Davidson batteries have lead plates and sulphuric acid electrolyte units of capacities suitable for load requirements under intended use.

NOTE

A new battery is shipped dry and must be activated by filling with battery grade sulphuric electrolyte before placing in service.

BATTERY CARE

Prompt and correct battery care determines the life span of the unit. Therefore, for a longer useful life, the battery solution level must be checked at weekly intervals. Add only pure distilled or approved water.

With a hydrometer or syringe, add water to each cell to raise level of solution up to level for type of battery as follows:

FL/FLH – Fill to triangle or circle at base of filler hole.

FX/FXE – Maintain level at upper level line on side of battery.

Be careful not to overfill. Overfilling will result in some of the electrolyte being forced out through cap vent holes, diluting or weakening the solution strength. An overflow of battery solution will cause cables to corrode and motorcycle parts near the battery to be damaged.

WARNING — Batteries contain sulphuric acid. Avoid contact with skin, eyes or clothing.

ANTIDOTE – External – Flush with water.

Internal – Drink large quantities of milk or water followed by milk of magnesia, vegetable oil, or beaten eggs. Call doctor immediately.

Eyes – Flush with water and get immediate medical attention.

Clean battery and terminals when necessary with a baking soda-water solution. Be careful to avoid getting any of the solution into the cap vent holes. When solution stops bubbling, flush off battery with clean water.

Coat terminals with grease or oil felt terminal post washers after wires have been attached to retard corroding.

TESTING BATTERY

Use the following instructions for testing battery condition. As a guide for determining when to start or stop charging, check charge state in all cells (Tests A and B). As a guide for determining battery condition, use load test C.

HOW TO TEST

Discharged, or less than 1/2 charged batteries (1.210 gravity or 2.04 open circuit cell voltage) must be recharged in order to have charge sufficient for testing. Use hydrometer (A), cell tester (B), or load tester (C), as follows:

A. Use of Hydrometer: (Refer to chart below)

1. Be sure to correct reading for temperature extremes. For each 10° above 80°F add 4 points, or deduct 4 points for each 10° below 80°F.

NOTE

Harley-Davidson Hydrometer, Part No. 96802-63, has built-in thermometer and correction chart and is recommended for testing all batteries.

2. Read gravity of each cell and record.
3. If any 2 cells vary more than 50 points, replace battery.
4. If cells are even or vary only slightly, battery is generally not "suspect."
5. Batteries with satisfactory specific gravity (1.220 or better) but very low or no open circuit voltage are probably not serviceable.

B. Use of Cell Tester: (Refer to chart below):

1. Remove surface charge.

NOTE

The Sun Model CT-230 voltmeter is recommended for battery cell test.

2. Put red prod on positive post and span cell cap with other prod to locate cell connector.
3. Read open circuit voltage of each cell and record.
4. If any 2 cells vary more than .05 volts (25% or 5 scale divisions), replace battery.
5. If cells are even or vary only slightly, the battery is generally not "suspect."

BATTERY CHARGE CONDITION

State of Charge	Specific Gravity (A)	Open Circuit Volts/Cell (B)
100%	1.250-1.270	2.10-2.12
75%	1.220-1.240	2.07-2.09
50%	1.190-1.210	2.04-2.06
25%	1.160-1.180	2.01-2.03

C. Use of Load Tester

1. Never use on discharged batteries or batteries under 3/4 charged (1.240 sp. gr.).

NOTE

The Sun Vat-26 Tester (or equivalent) is recommended for load testing the battery.

2. Fully charge the battery before testing. Load battery to 3 x amp hour rating using the Sun Vat-26 Tester. (The Harley-Davidson 32 amp hr battery should be loaded to 96 amperes and the 7 amp hr battery to 21 amperes.) Voltage reading after 15 seconds should be 9.6 or more. Note: Voltmeter leads must be connected directly to battery posts.

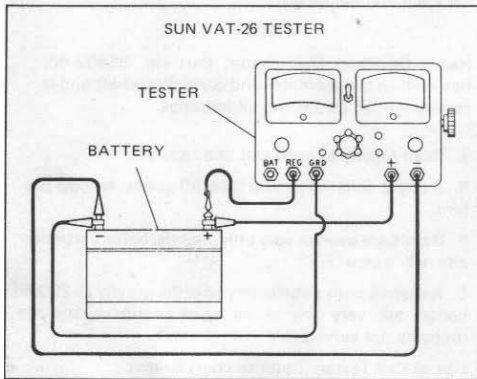

Figure 5-25. Testing Battery Capacity

CHARGING BATTERY

Never allow a battery to stand in a discharged condition. Start charging it at once at the recommended continuous charge rate. Be sure charger is properly connected and adjusted observing positive (+) and negative (-) polarity to battery.

To determine the amount or condition of a battery charge, check solution in each cell with a battery hydrometer or individual cell voltage with a voltmeter as outlined in paragraph titled "Testing Battery," above. When hydrometer reading is 1.200 or less, battery is considered discharged and should be removed from motorcycle and charged at the following maximum continuous charge rate using appropriate 12 volt charger.

12 volt 7 ampere hour battery - 1.5 amperes
12 volt 19 ampere hour battery - 4 amperes
12 volt 32 ampere hour battery - 4 amperes

A higher battery charge rate will heat and damage the battery. For this reason, do not allow the small motorcycle battery to be charged in the same line with large batteries. Hydrometer reading of a fully charged battery in good condition, with full strength electrolyte will be 1.270 or higher.

WARNING — Hydrogen gas, formed when charging, is explosive. Avoid open flame or electrical spark near battery.

Allowing a battery to remain in a discharged condition will shorten its life. It is important that a battery be kept well charged during below freezing weather.

RECLAIMING SULPHATED BATTERY

If a battery has been allowed to stand in a discharged condition for a period of time, the lead sulphate in the plates will crystallize and not take a charge at normal rates. Such batteries should be charged at half the specified continuous rate for twice the computed time. A longer charging time at a slower rate will many times break down the crystalline structure into active materials and restore the battery.

CHANGING ELECTROLYTE

In normal service with average care, it is never necessary to change electrolyte for the lifetime of the battery. However, if the battery solution is spilled, diluted as a result of careless water addition, or neutralized by the addition of an alkaline substance, the battery solution may be changed and in some cases near full capacity restored.

A weak acid solution may be detected by charging the battery until all cells gas freely and the gravity has not shown a rise for three successive readings taken at hourly intervals. "Gassing" is evidenced by a bubbling action in the electrolyte that may be detected by sight or sound. Do not change electrolyte in a battery with one or more cells that fail to gas. Such a condition indicates a structural failure.

Pour solution out of charged battery and fill with water. Charge battery again until maximum specific gravity is reached. Pour out this solution and add prepared battery electrolyte to specified level and charge again for a short length of time for full capacity.

Check specific gravity and add a little water if necessary to bring solution down to desired maximum limits.

The value of changing electrolyte in a fairly old battery is questionable. By tipping over such a battery to drain the solution, the sloughed-off waste materials accumulated by repeated charging and discharging actions might be dislodged from the sediment chambers in the bottom of the battery and deposited in the separators. This material is an electrical conductor and thus may "tree" or catch in the separators and cause a short circuit.

HORN

Horn is shown in Figure 5-26. If the horn fails to blow or does not blow satisfactorily, check for loose, frayed or damaged wiring leading to horn terminals, discharged battery, etc. If these steps do not correct the trouble, turn in contact point adjusting screw, located back of horn, until horn just gives a single clock - then retard screw until best tone is obtained. If horn fails to operate after moving adjusting screw, entire horn must be replaced because it is permanently riveted together. Mounting parts are replaceable.

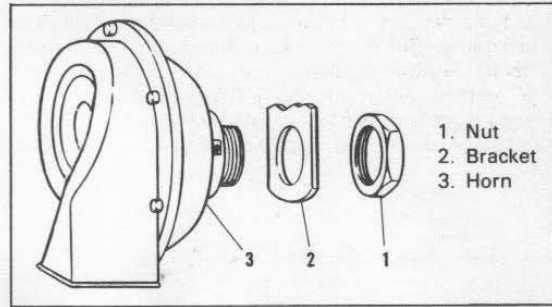

Figure 5-26. Horn

STARTER MOTOR

DESCRIPTION

The starter motor is a 12-volt, series field 4-pole drive motor which engages the clutch ring gear through a Bendix type drive and reduction gear unit. A solenoid relay provides battery current directly to the motor. The solenoid is controlled by a button switch on the handlebar. On some models control circuit has a cut-out switch in the transmission cover. Switch plunger contacts a nub on the shifter cam only when transmission is in neutral to complete the starting circuit. This prevents starter operation when transmission is in gear.

NOTE

Starter motor should never be operated continuously for more than 30 seconds without pausing to let it cool for at least two minutes. The motor is not designed for continuous operation and serious damage may result.

TROUBLESHOOTING

GENERAL

The starter motor is designed to be corrosion resistant and requires very little maintenance. However, to ensure satisfactory operation, periodic inspection of brushes and commutator should be made. In the event starter motor fails to operate satisfactorily, the following checks should be made before removing motor for inspection:

WIRING

Make sure the mounting and wiring connections are tight and in good condition. The solenoid switch should be firmly mounted and all wiring connections should be clean and tight. Also inspect the connections to the battery and return circuit, as loose or dirty connections anywhere in the circuit will cause high resistance and reduced motor efficiency.

BATTERY

If the connections and wiring are found to be satisfactory, the battery should be checked to determine its state of charge, see "Charging Battery." If the battery is charged and battery voltage is reaching the motor without any excessive losses in wiring or connections, the trouble may be attributed to either the engine or the starter motor itself.

SWITCHES

If the battery is charged but there is no current flow to motor at all, trouble is probably in handlebar button switch, transmission cutout switch or the solenoid switch. This can be determined by bypassing each switch with a heavy jumper, refer to "Wiring Diagram."

ENGINE

Excessive friction in the engine from tight bearings or pistons or from heavy oil obviously makes engine harder to crank. However, if engine is known to be in normal condition and the rest of the starting system is satisfactory, the starter motor should be removed for further checking.

NOTE

Electrical tests to locate cause of starting system failures can be made using the Sun Vat-26 Tester and applicable Service Bulletins.

STARTER MOTOR AND DRIVE

REMOVING AND INSTALLING STARTER MOTOR

Disconnect solenoid cable from starter motor terminal. Remove attaching nuts and lockwashers (1, Figure 5-27) which fasten starter motor housing (3) to studs on chain housing. Remove starter motor end support plate (not shown) from transmission. It may be necessary to loosen and raise battery carrier to provide clearance. Remove starter motor (2) and starter shaft housing (3) from motor-cycle as an assembly.

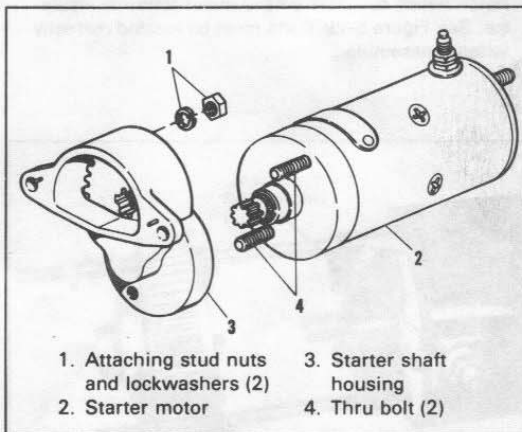

Figure 5-27. Removing Starter Motor

PRESTOLITE STARTER MOTOR

DISASSEMBLING AND ASSEMBLING (Figure 5-28)

Remove thru bolts (1) with washers and lockwashers (2). Remove commutator end cover (3) holding brush plate (4) in place if necessary.

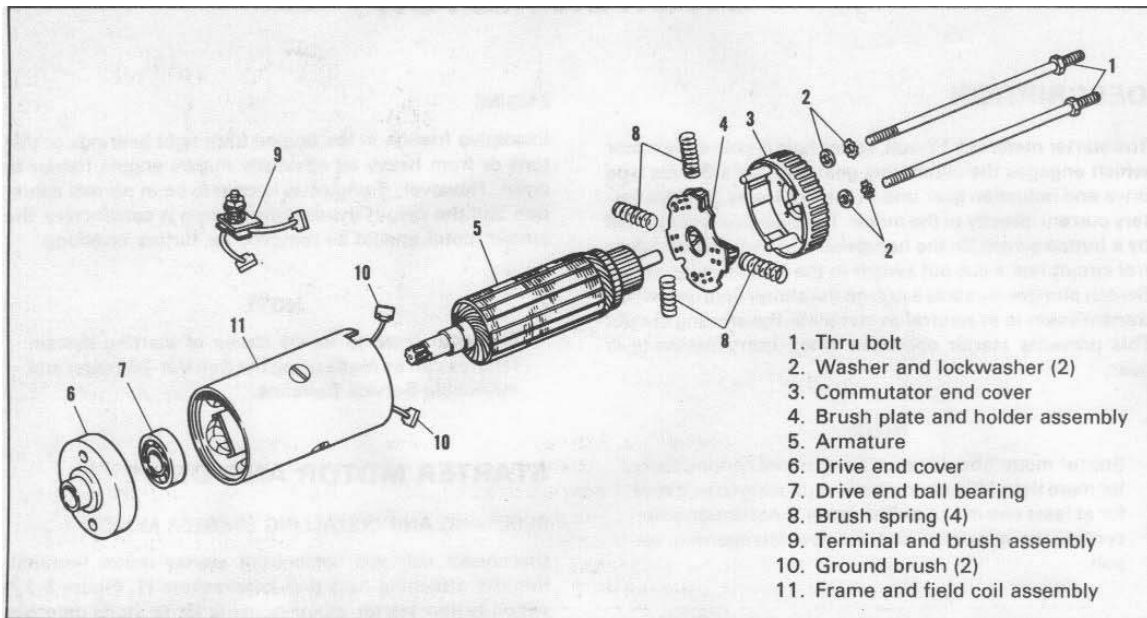

Figure 5-28. Prestolite Starter Motor - Exploded View

NOTE

End cover is marked with a double line next to the motor terminal. Also brush holder has a positioning notch which registers on the motor terminal insulator. See Figure 5-29. Parts must be located correctly when reassembled.

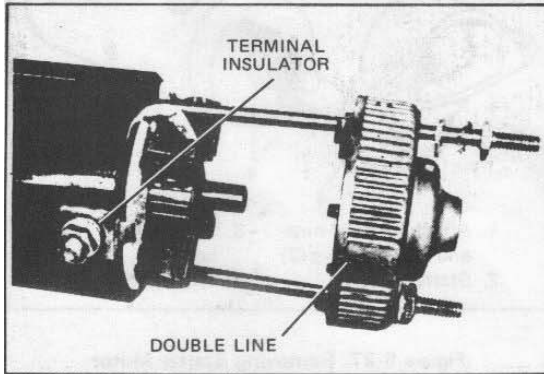

Figure 5-29. Positioning Prestolite Starter Motor Cover

Armature (5) and drive end cover (6) with bearing (7) are removed as an assembly. Bearing (7) is a light press fit on armature shaft and is staked in end cover (6).

NOTE

To prevent brushes from escaping holders, insert a spool of slightly larger diameter than the commutator underneath brushes when brushes are half exposed as armature is withdrawn from frame. In this way armature can be reinstalled without removing brushes from holders.

Reassembly is essentially the reverse of the disassembly procedure. If brushes (9) and (10) and springs (8) have been released from holder, use clips or clamps as shown in Figure 5-30 to hold them in place while installing armature. Note that drive end of frame is notched to fit drive end cover. Line up positioning notch in the brush holder assembly with terminal insulator. Line up positioning mark on commutator end head with motor terminal. Install thru bolts, tightening to 20-25 in-lbs torque.

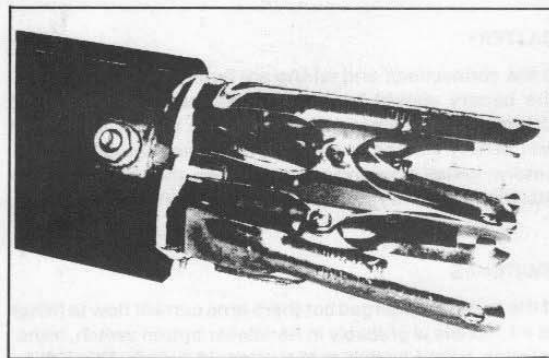

Figure 5-30. Using Clamps to Hold Prestolite Brushes in Place

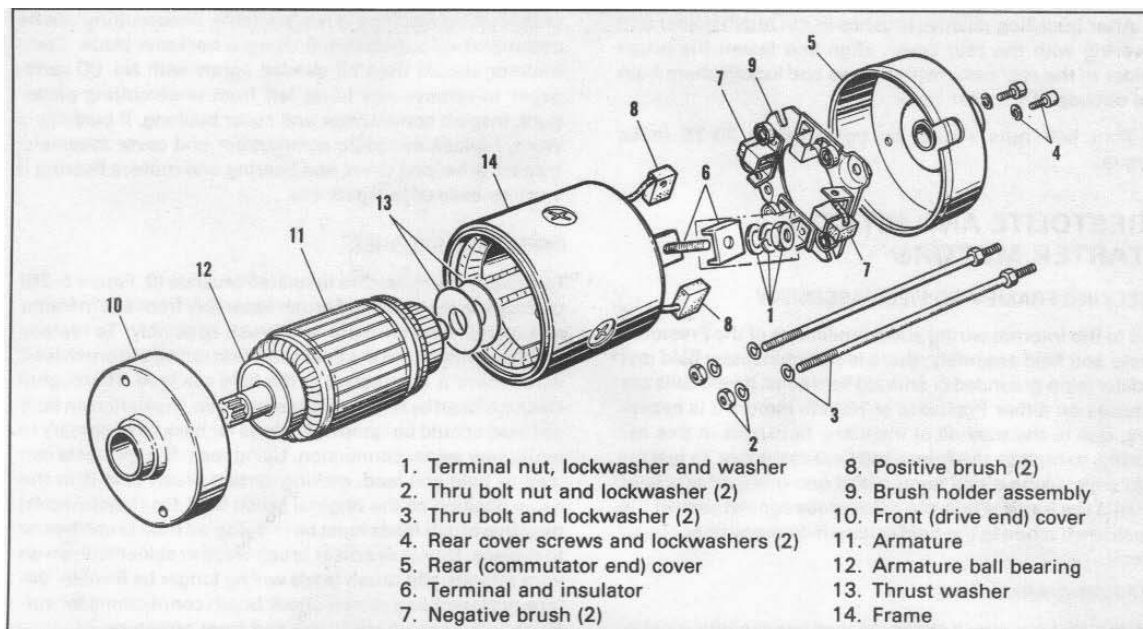

Figure 5-31. Hitachi Starter Motor - Exploded View

HITACHI STARTER MOTOR

DISASSEMBLING AND ASSEMBLING (Figure 5-31)

Remove terminal nut, washer and lockwasher (1). Remove nuts and lockwashers (2) from thru bolts (3). Remove thru bolts with lockwashers (3). Remove two screws and lockwashers (4) fastening the rear cover.

Separate the rear cover (5) from the starting motor frame as follows: tap the rear cover with a soft hammer to make an opening between the rear cover and the frame. Next insert a screwdriver into the opening and push out the rear cover taking care to see that terminal and insulator (6) remain in place next to motor frame.

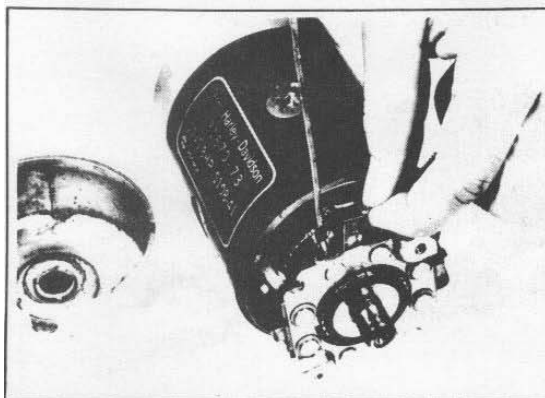

Figure 5-32. Removing Brushes - Hitachi Motor

Lift the brushes from the commutator. As shown in Figure 5-32, pulling up the brush spring with a steel wire and pull out the brushes. Note that two minus brushes (7) have to be withdrawn slightly to be held in the brush guide, making use of the action of the brush spring. The other two plus brushes (8) should be completely removed from the brush holder assembly (9) as shown in Figure 5-33.

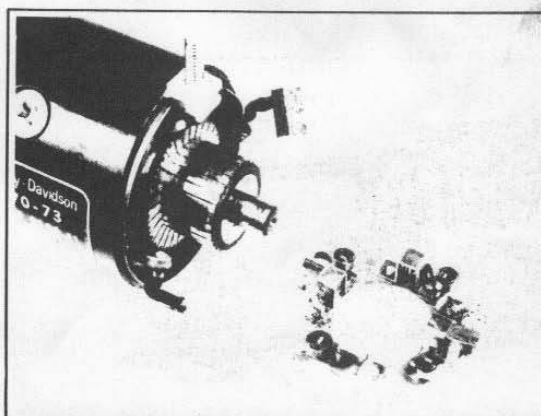

Figure 5-33. Hitachi Brushes and Brush Holder

Remove front cover (10), armature (11) with ball bearing (12) and thrust washer(s) (13).

Assemble starting motor in reverse order of disassembly, noting the following:

1. To determine the proper position of frame and front cover, align notch in cover with projected part of the frame.

2. After installing positive brushes in the brush holder and covering with the rear cover, align and fasten the brush holder to the rear cover with screws and lockwashers from the outside of the rear cover.
3. Thru bolt nuts should be tightened to 20-25 in-lbs torque.

PRESTOLITE AND HITACHI STARTER MOTORS

CHECKING FRAME AND FIELD ASSEMBLY

Due to the internal wiring and connections of the Prestolite frame and field assembly, there is no satisfactory field test to determine grounded or shorted field coils. If field coils are required on either Prestolite or Hitachi motors it is necessary, due to the method of installing field coils in this assembly, to replace the frame and field assembly. To test for field coils, using a test lamp, place one probe of test light against the frame. Place the other probe against each of the brushes attached to the field coils to indicate open or closed circuit.

REPAIRING ARMATURE

If commutator is dirty it can be cleaned by polishing with No. 00 sandpaper - not emery cloth. If commutator is worn, out of round or has high mica insulation between segments, commutator can be turned down in a lathe. Mica should then be undercut $1/32$ in. deep with an undercutting machine and slots cleaned out to remove dirt or copper dust. If

undercutting machine is not available, undercutting can be accomplished satisfactorily using a hacksaw blade. Commutator should then be sanded lightly with No. 00 sandpaper to remove any burrs left from undercutting procedure. Inspect commutator end cover bushing. If bushing is worn, replace complete commutator end cover assembly. Inspect drive end cover and bearing and replace bearing if worn to excessive looseness.

REPLACING BRUSHES

To replace the Prestolite insulated brushes (9, Figure 5-28) remove the terminal and brush assembly from slot in frame and install new terminal and brush assembly. To replace brushes attached to the field coils, first cut off old brush lead wire where it is attached to the field coil lead. Thoroughly clean coil lead by filing off old connection. Insulation on field coil lead should be removed only as far back as necessary to make new solder connection. Using rosin flux, solder brush lead to field coil lead, making certain brush lead is in the same position as the original brush lead. On Hitachi model negative brush leads must be unsoldered from brush holder to replace. Do not overheat brush leads or solder will run on wire strands and brush leads will no longer be flexible. Before reassembling motor, check brush connections for sufficient clearance from frame and from armature.

Replace brushes when worn down close to the following minimum lengths.

- Prestolite $1/4$ in.
- Hitachi $7/16$ in.



TOOLS



Order from Sun Electric Corp., Chicago, Ill.

Sun Power Timing Light Model PTL-45

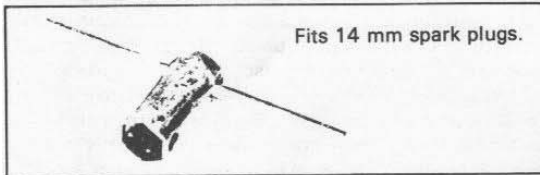

Fits 14 mm spark plugs.

Part No. 94575-58A Spark Plug Wrench

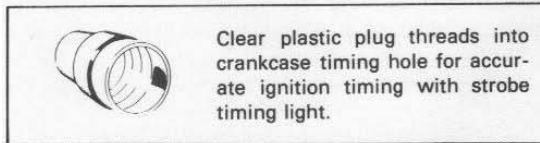

Clear plastic plug threads into crankcase timing hole for accurate ignition timing with strobe timing light.

Part No. 96295-65 Timing Mark View Plug



For testing state of charge of storage batteries. Specific gravity of electrolyte can be corrected for temperature extremes by means of built-in thermometer.

Part No. 96802-63 Battery Hydrometer, with Temperature Correction Feature

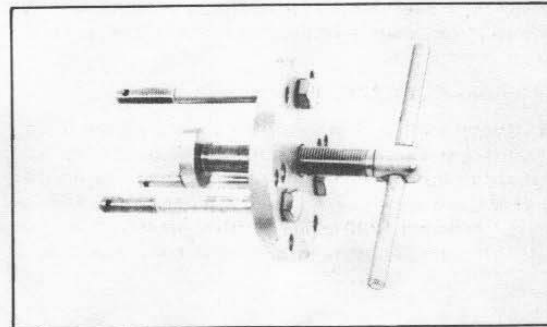

Part No. 95960-52A Alternator Rotor Puller

TABLE OF CONTENTS

	PAGE
General	6-1
Instruments	6-1

INSTRUMENTS

SPEEDOMETER

GENERAL

Lubricate cable core every 5000 miles with graphite grease.

To lubricate the speedometer drive core or replace a damaged or broken core, proceed as follows:

Remove instrument panel cover. Remove screws that secure speedometer head to instrument panel base. Lift speedometer head as far as casing will permit, and with pliers, loosen case coupling nut from speedometer head. Withdraw core from casing. To free a broken core from casing, disconnect lower case coupling nut from speedometer drive unit. Withdraw core from lower case end.

TACHOMETER

GENERAL

Lubricate cable core every 5000 miles with graphite grease if applicable.

To lubricate the tachometer drive core or replace a damaged or broken core proceed as follows:

With a pliers remove case coupling nut from tachometer and withdraw core from casing. To free a broken core from casing, disconnect lower case coupling nut from drive unit. Withdraw core from lower case end.

To free tachometer head, disconnect tachometer cable casing as described above. Remove two nuts securing tachometer head, and lift head from its mounting bracket.

To install a tachometer head and drive case, reverse the order of disassembly.

Install core in upper end of casing, applying a light coat of graphite grease to the core as it is inserted into position. Engage squared lower end of core in drive shaft. Connect case coupling upper end to the head, engaging squared end of core in shaft. Be sure to tighten both case coupling nuts securely.



Harley-Davidson

Milwaukee, Wisconsin 53201