



**HARLEY-DAVIDSON**

**GENUINE PARTS**

**& ACCESSORIES**

79

**99460 - 66**

HARLEY-DAVIDSON  
**ELECTRA-GLIDE**  
RIDER HANDBOOK



# TABLE OF CONTENTS

Section	Page
SPECIFICATIONS . . . . .	2
CONTROLS. . . . .	7
RIDING. . . . .	13
SERVICING . . . . .	21
ENGINE . . . . .	23
TRANSMISSION AND CHAINS . . . . .	25
CHASSIS . . . . .	27
MAINTENANCE . . . . .	31
ENGINE . . . . .	31
TRANSMISSION . . . . .	37
CHASSIS . . . . .	43
ELECTRICAL . . . . .	51

Harley-Davidson products are manufactured under one or more of the following patents:  
U. S. Patents — D-199,479, 2510222, 2574739, 2770869, 2783927,  
2788676, 2872660, 2986162, 2987934, 2998809, 3116089, 3144860,  
3144631. Canadian Patents — 487981, 490652.

## INTRODUCTION

As the owner of a new Harley-Davidson motorcycle, you will enjoy a thrilling new experience in motorcycling pleasure. Harley-Davidson has designed for you the ultimate in motorcycles — speed, acceleration, comfort and safety — precision built and engineered to give you many thousands of miles of dependable, carefree riding.

This handbook contains information you will need to know to operate and care for your Harley-Davidson so that it will provide dependable and trouble-free service. Follow the instructions carefully and you will be assured of the best performance that your motorcycle can give.

This handbook is intended for the owner and contains instructions for owner care and maintenance of a minor nature. Information covering repair of major units such as engine, transmission, etc. is provided in the Harley-Davidson Service Manual. Work of this kind requires the attention of a skilled motorcycle mechanic and the use of special tools and equipment. Your Harley-Davidson dealer has the facilities, experience, and genuine Harley-Davidson parts to properly render this valuable service.

### NOTE

Tools for owner use, as recommended in this handbook for service and minor repairs, are supplied in a tool kit which can be purchased from your Harley-Davidson Dealer.

# SPECIFICATIONS

## DIMENSIONS

Wheel Base . . . . .	60 in.
Overall Length . . . . .	92 in.
Overall Width . . . . .	35 in.

## CAPACITIES

Fuel Tank Total . . . . .	5 or 3-3/4 Gallons (U.S.)
Reserve . . . . .	1 or 1-1/4 Gallon (U.S.)
Oil Tank . . . . .	4 quarts (U.S.)
Transmission . . . . .	1-1/2 Pints (U.S.)

## ENGINE

Model Designation Letters. . . . .	FL - FLH
Number of Cylinders . . . . .	2
Type . . . . .	45 Degree V Type
Horsepower . . . . .	FLH . . . . . 60.0 HP at 5,400 R.P.M.
	FL . . . . . 55.0 HP at 5,400 R.P.M.
Taxable Horsepower. . . . .	9.44
Bore . . . . .	3-7/16 in. (87.3mm)
Stroke . . . . .	3-31/32 in. (100.8mm)
Piston Displacement. . . . .	73.66 cu. in. (1207 cc)

Torque . . . . .	FLH . . . . . 65 lb-ft at 3,200 R.P.M.
	FL . . . . . 62 lb-ft at 3,200 R.P.M.
Compression Ratio . . . . .	FLH . . . . . 8 to 1
	FL . . . . . 7.25 to 1

## NOTE

The engine (serial) number (11, fig. 2) of your Harley-Davidson is stamped on the left side of the engine crankcase. Always give this number when ordering parts or making any inquiry about your motorcycle.

## IGNITION SYSTEM

Circuit Breaker Point Gap . . . . .	.022 in.
Spark Plugs - Size. . . . .	14 mm
Gap . . . . .	.025 to .030 in.
Heat range for average use . . . . .	No. 3-4
Spark Timing. . . . .	Retard 5° B.T.C.
Automatic Advance . . . . .	35° B.T.C.

## TRANSMISSION

Type . . . . .	Constant Mesh
Speeds - Foot Shift . . . . .	4 Forward
Hand Shift . . . . .	4 Forward
	(Optional) 3 Forward and 1 Reverse

## SPROCKETS AND GEAR RATIOS

Sprocket Teeth	Solo		Sidecar	
	FL	FLH	FL	FLH
Clutch	37	37	37	37
Transmission	22	22	22	22
Rear Wheel	51	51	51	51
Engine Sprocket (4-Speed Transmission)	23	24	22	22
Engine Sprocket (3-Speed Transmission)	23	24	19	22
High Gear Ratio (4-Speed Transmission)	3.73	3.57	3.90	3.90
High Gear Ratio (3-Speed Transmission)	3.73	3.57	4.50	3.90

The following tire inflation pressures are based on rider and passenger weights of approximately 150 lbs. each. For each 50 lbs. extra weight, increase pressure of rear tire 2 lbs., front tire 1 lb., and sidecar tire 1 lb.

## TIRE DATA

Tire Size		Tire Pressure - PSI		
		Front	Rear	Sidecar
Solo Rider	4.00 x 18	14	16	
	4.50 x 18	12	14	
	5.00 x 16	12	14	
Rider and One Passenger	4.00 x 18	18	26	
	4.50 x 18	12	16	
	5.00 x 16	12	16	
Rider And One Sidecar Passenger or 150 lb.	4.00 x 18	20	24	14
	4.50 x 18	14	16	14
	5.00 x 16	14	16	14

### IMPORTANT

5.00 x 16 tires supplied as original equipment on Electra-Glide Models are identified by the numeral "100" on tire sidewall. These tires were designed especially for your Harley-Davidson Electra-Glide to provide maximum roadability. When tires need replacement, use only type "100" tires which are readily obtainable at your Harley-Davidson dealer.

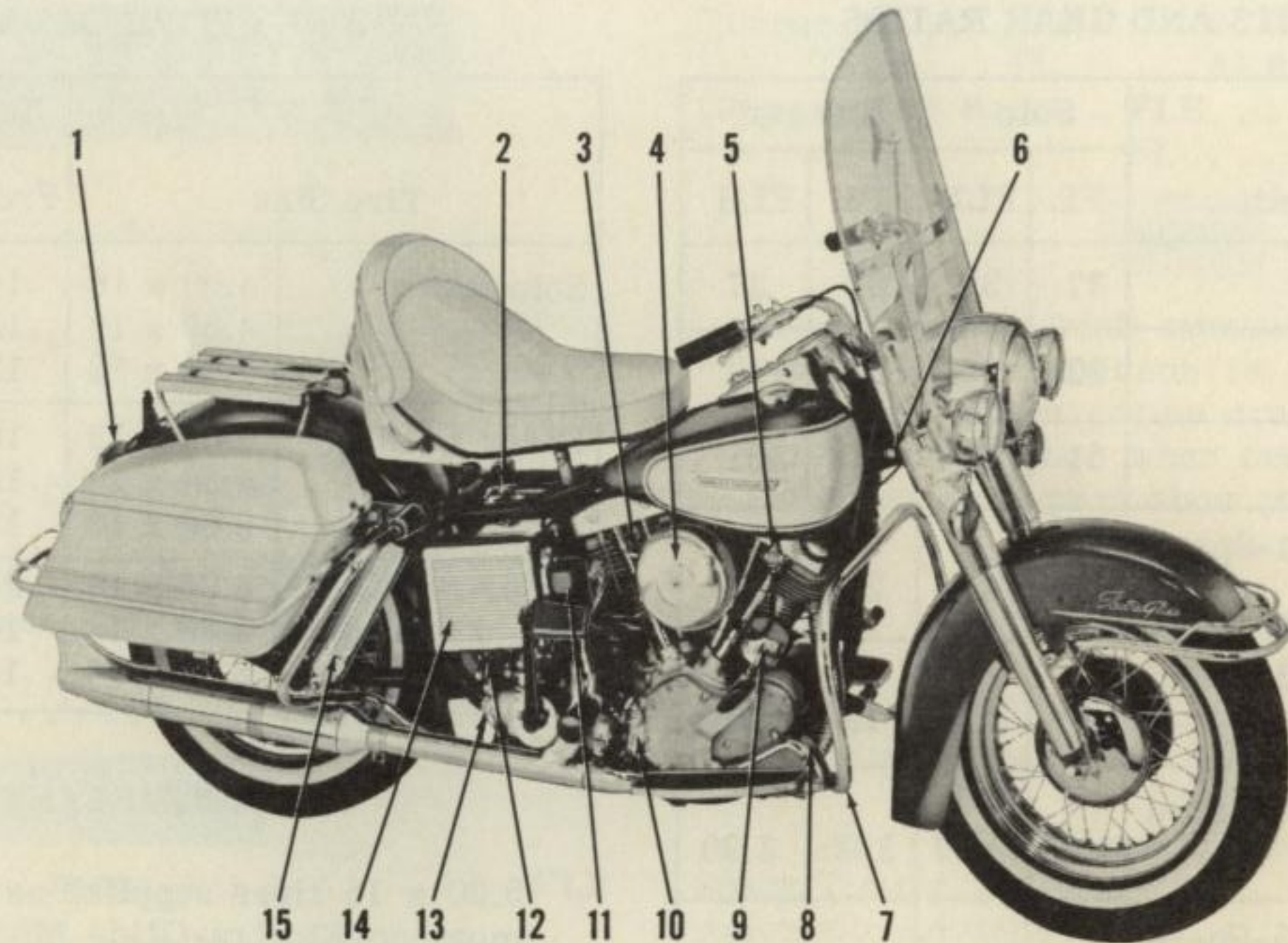

- 1. Tail Lamp
- 2. Oil Tank Cap and Gauge
- 3. Carburetor Choke Lever
- 4. Carburetor Air Cleaner
- 5. Gas Tank Valve

- 6. Head Lock
- 7. Safety Guard
- 8. Hydraulic Brake Master Cylinder
- 9. Ignition Circuit Breaker
- 10. Oil Pump and Pressure Switch

- 11. Regulator
- 12. Electric Starter
- 13. Transmission Oil Filler Plug
- 14. Battery
- 15. Rear Shock Absorber

**FIGURE 1. RIGHT SIDE VIEW**

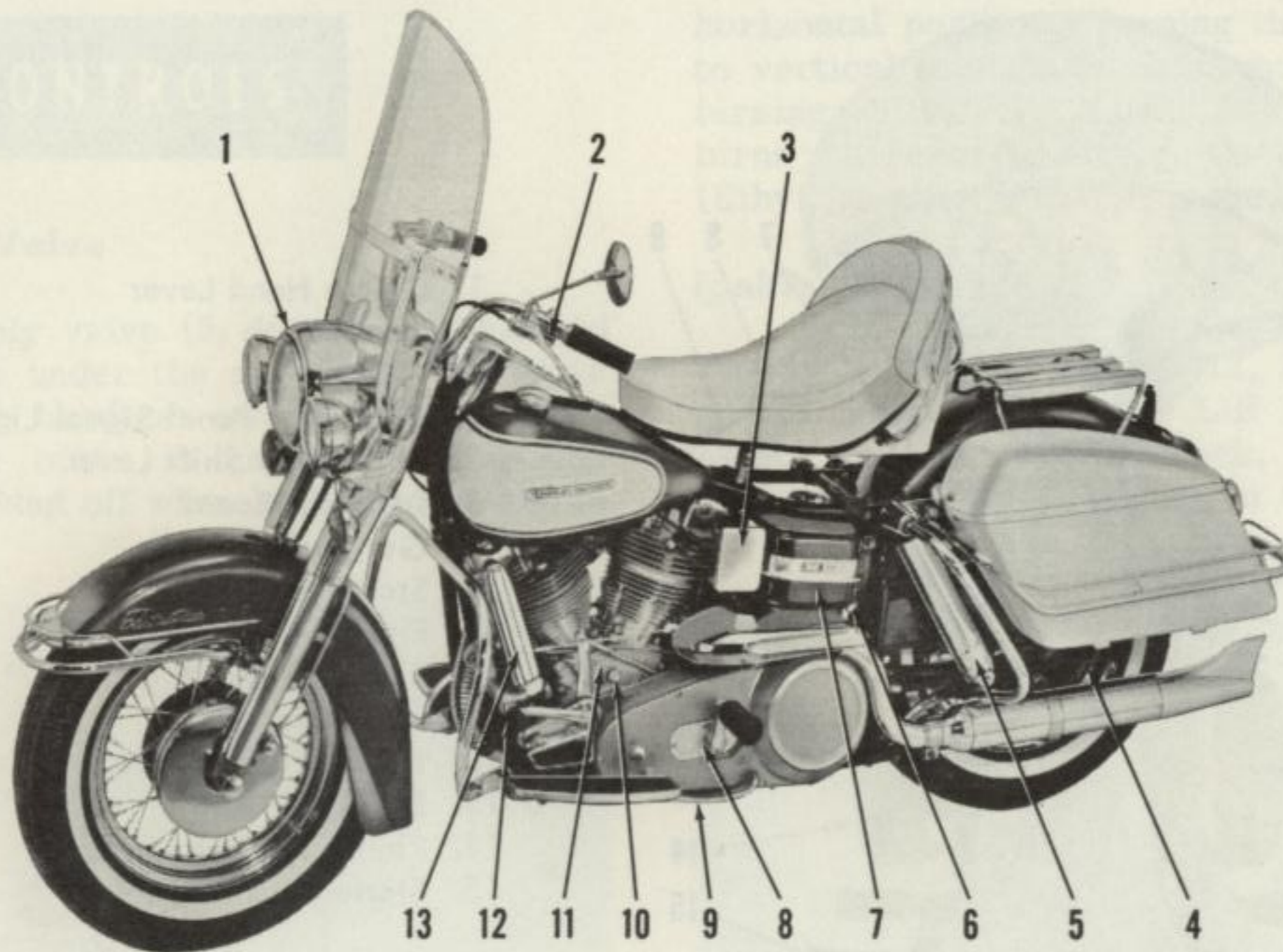

- 1. Headlamp
- 2. Headlamp Dimmer Switch
- 3. Ignition Coil
- 4. Rear Drive Chain

- 5. Rear Shock Absorber
- 6. Oil Tank Drain Plug
- 7. Oil Tank
- 8. Front Chain Inspection Hole Cover
- 9. Jiffy Stand

- 10. Timing Inspection Hole Plug
- 11. Engine (Serial) Number
- 12. Generator
- 13. Hand Clutch Booster

**FIGURE 2. LEFT SIDE VIEW**

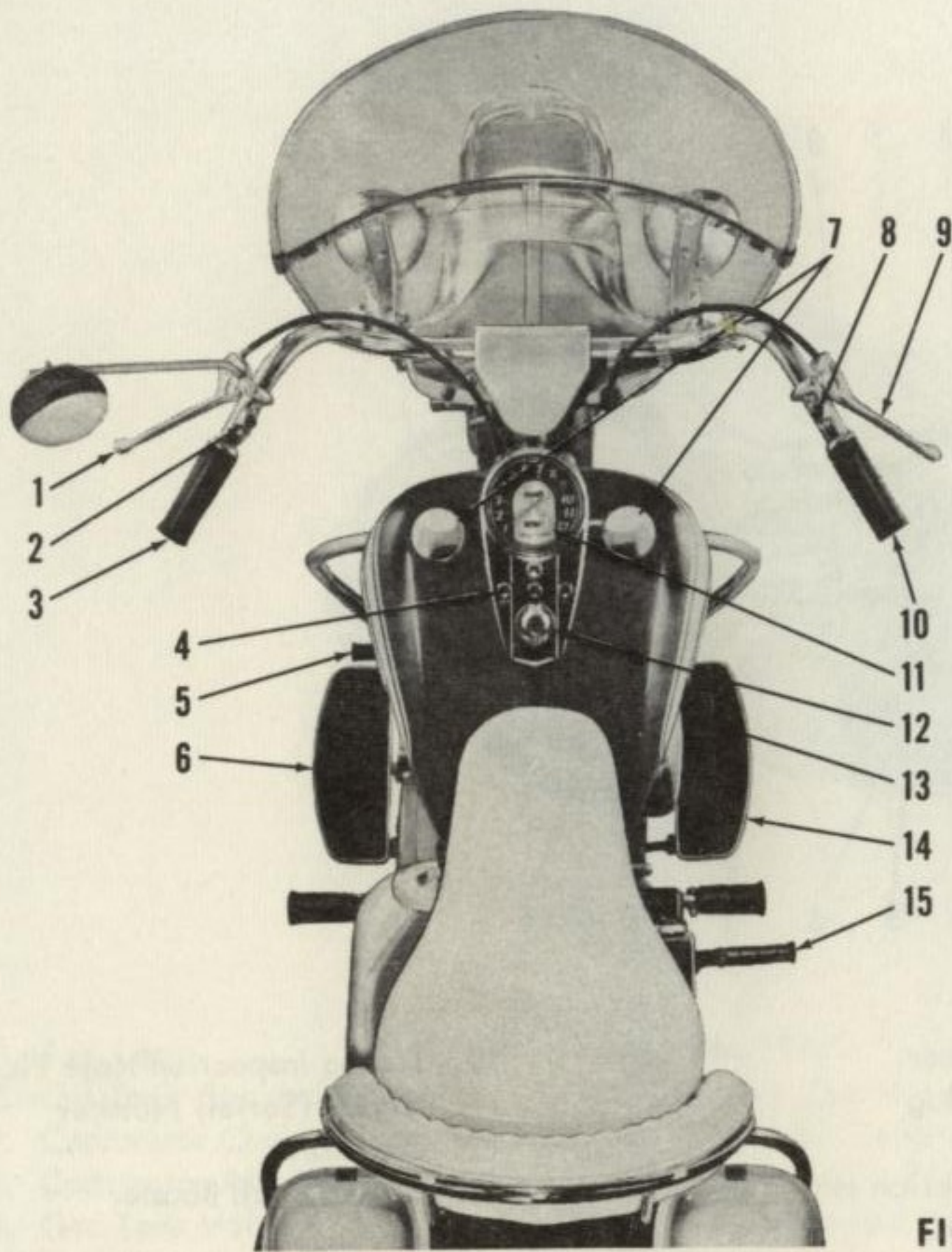

1. Clutch Hand Lever
2. Horn Button
3. Grip
4. Instrument Panel Signal Lights
5. Foot Gear Shift Lever
6. Left Foot Board
7. Gas Tank Cap (2)
8. Starter Button
9. Front Brake Hand Lever
10. Throttle Control Grip
11. Speedometer
12. Ignition-Light Switch
13. Rear Hydraulic Brake Foot Lever
14. Right Foot Board
15. Starter Crank Pedal

FIGURE 3. TOP VIEW

# CONTROLS

## Gasoline Supply Valve

The gasoline supply valve (5, figure 1) is located on the right side under the gas tank. The valve (figure 4) has two handles; one is marked "RESERVE" and the other is unmarked. Gasoline to carburetor is shut off when both handles are in

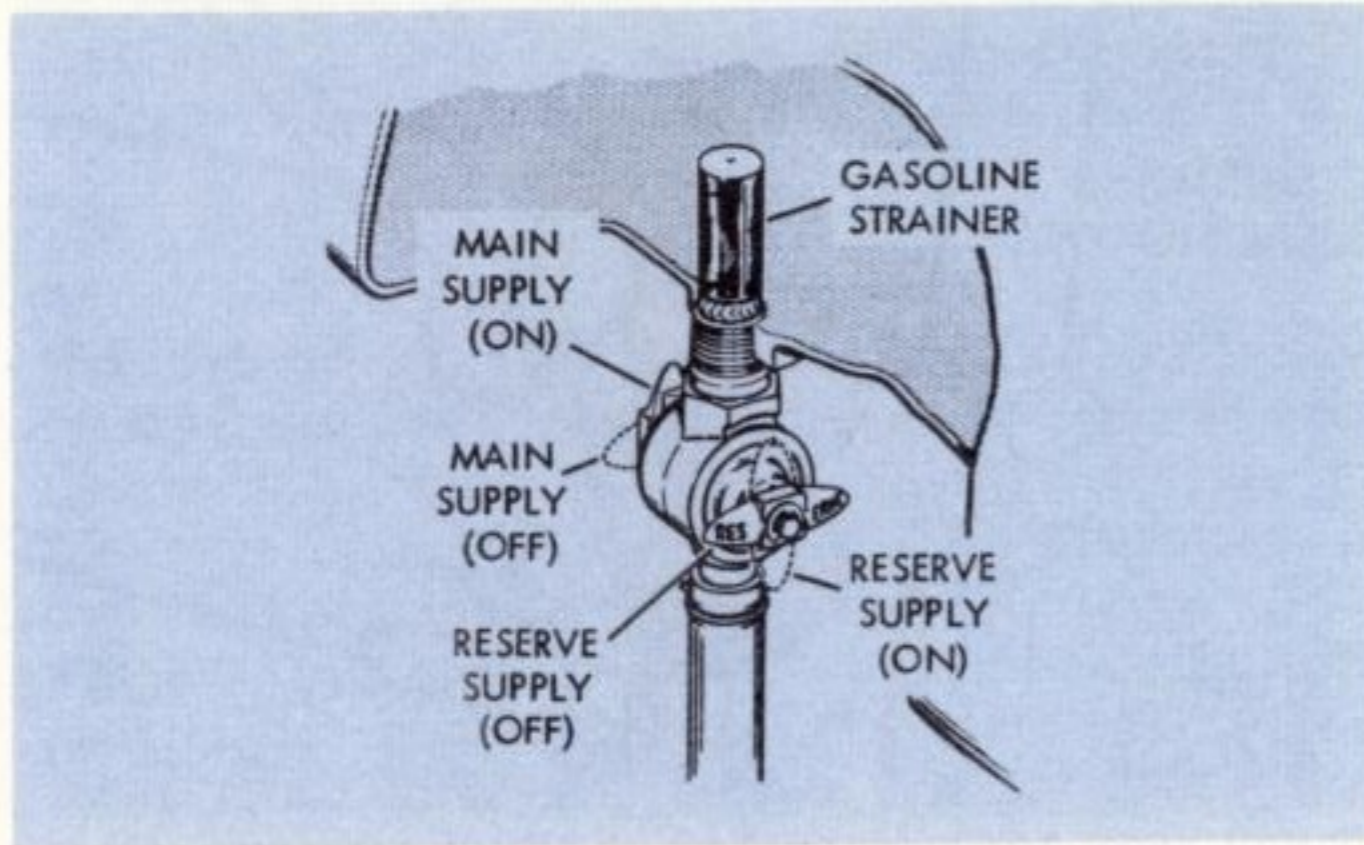

FIGURE 4. GASOLINE SUPPLY VALVE

horizontal position. Turning the unmarked handle to vertical position turns on main gasoline supply; turning "RESERVE" handle to vertical position turns on reserve supply. Use "Premium Grade" (Ethyl) or other anti-knock gasoline.

## Ignition-Light Switch

The ignition-light switch (12, figure 3) is located on the instrument panel. Lift lock cover and use switch key to lock or unlock. It is not necessary to keep the key inserted in the lock to operate

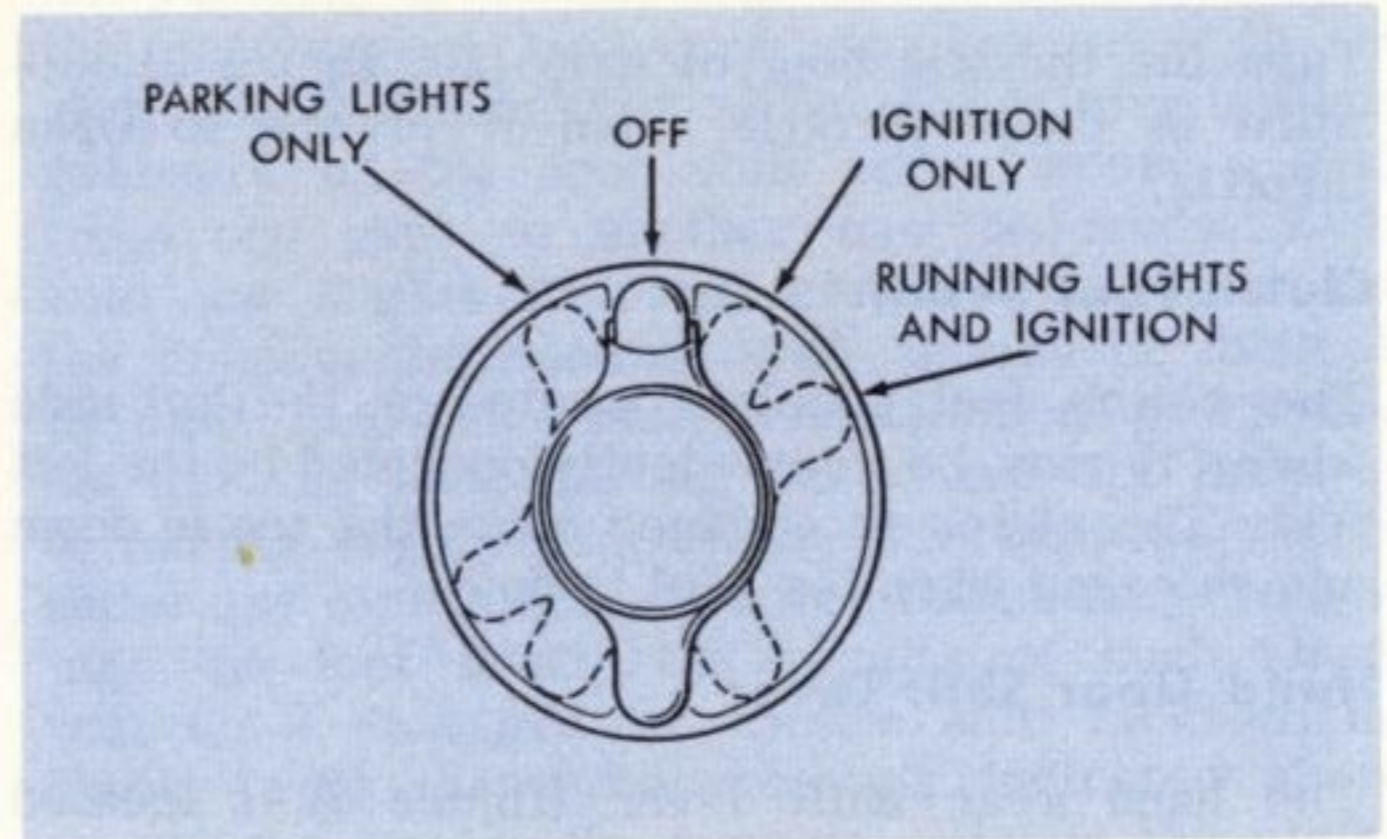

FIGURE 5. IGNITION-LIGHT SWITCH

this switch after it has been unlocked. The center position of the switch (figure 5) is the off position for both lights and ignition. The left of center position is for parking lights only; the first right position is for ignition only and the second right position, for ignition and running lights. The switch can be locked only in the off and the park positions. Remember that lighting the headlamp when the engine is not running also turns the ignition on. Make a record of key number so that it can easily be replaced in case of loss.

### Throttle Control Grip

Turn the throttle control grip (10, figure 3) outward to close throttle; turn it inward to open throttle.

### Clutch Foot Pedal

The clutch foot pedal is located on the left side where it may be conveniently operated by the left foot. The clutch is engaged when the toe is down and released when the heel is down.

### Hand Gear Shift Lever

The hand gear shift lever (figure 6) is located on the left side and the various positions are plainly marked on shifter gate. This lever must

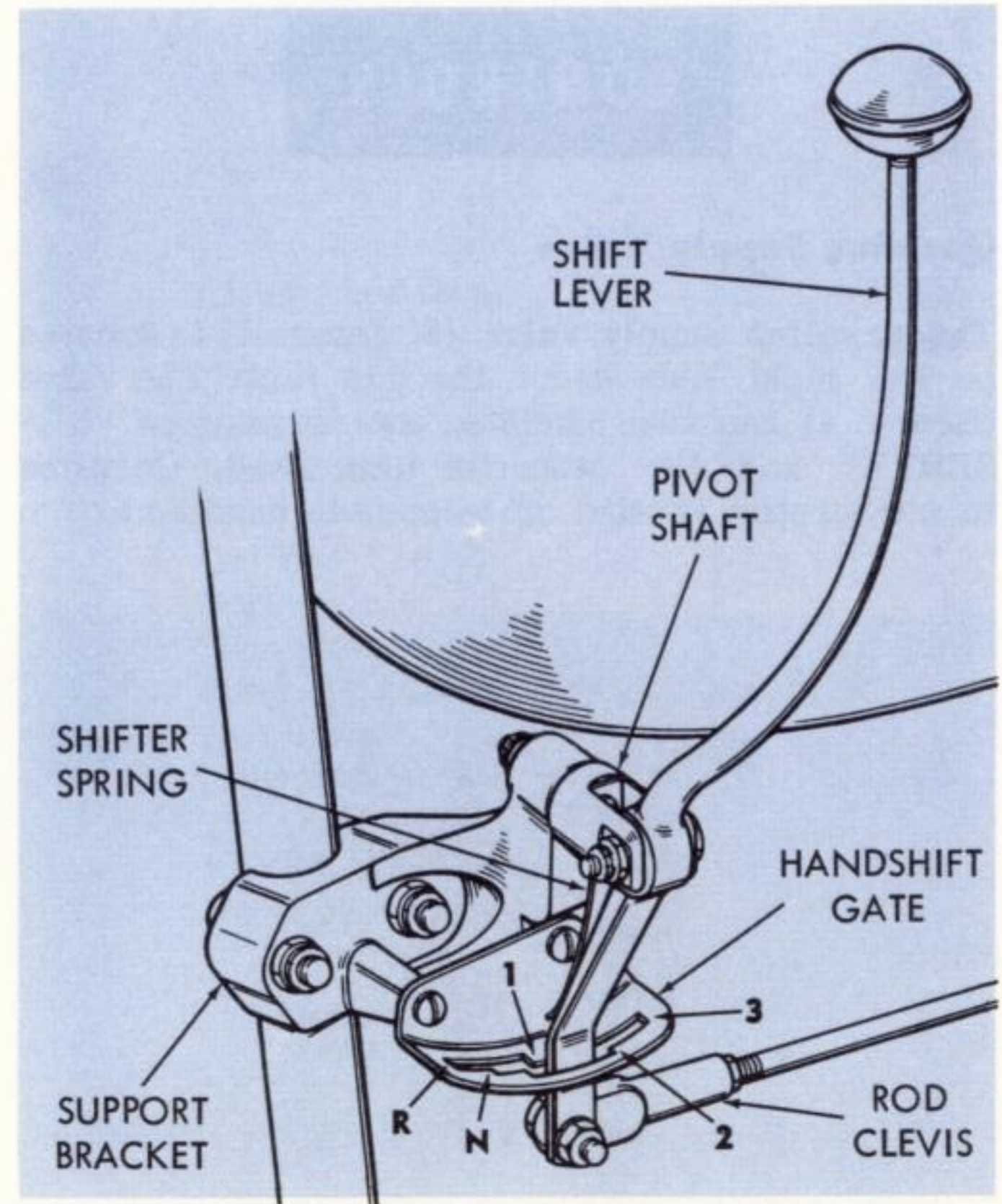

FIGURE 6. HAND GEAR SHIFT LEVER

be at neutral (N) and the clutch engaged when starting the engine. **FULLY RELEASE THE CLUTCH BEFORE SHIFTING.** Move upper ball end of lever forward to shift into 1st, 2nd and 3rd gears. Move shift lever to rear of neutral to shift into reverse. Gear positions are marked on gate.

### **Clutch Hand Lever**

The clutch hand lever (1, figure 3) is located on the left handle bar where it can be conveniently operated with the left hand. The clutch is released by squeezing the control lever to the handle bar. The clutch is engaged by slowly releasing the control lever to its extended position.

### **Foot Gear Shift Lever**

The foot gear shift lever (5, figure 3) is located on the left side where it may be conveniently operated by the left foot. Pushing foot lever all the way down (full stroke) shifts transmission into the next lower gear; lifting foot lever all the way up (full stroke) shifts transmission into the next higher gear. The operator must release foot lever after each gear change to allow it to return to its central position before another gear change can be attempted or made.

Neutral position is between first (low) and second gears, and is indicated by green light on the instrument panel when ignition-light switch is turned on. First gear is the last gear position obtained by pushing foot lever full strokes downward. To shift from first gear to neutral, lift foot lever one half of its full stroke. The shift to neutral can also be made from second gear by pushing foot lever downward one half its full stroke.

With the motorcycle standing still and the engine not running, it usually will be necessary to move the motorcycle backward or forward with the clutch fully disengaged while maintaining a slight pressure on the foot shift lever before a shift from one gear to another can be made. Even with the engine running, clutch disengaged and the motorcycle standing still, it may be difficult to shift gears because transmission gears are not turning and shifting parts are not lined up to permit engagement. When this happens, do not under any circumstances force the shift by "roughing" the foot lever; the results of such abuse will be a damaged or broken shift mechanism. Either roll the motorcycle as indicated above or, if the engine is running, engage the clutch very slightly and at the same time apply light

pressure to the foot lever to make the shift. Both these procedures set the transmission gears in motion and permit the shift to be made easily.

## Brakes

The brake foot pedal (13, figure 3) on the right hand side operates the rear wheel hydraulic brake while a convenient hand lever (9, figure 3) operates the front wheel mechanical brake.

## Head Lock

The head lock (6, figure 1) is located on the right side and locks the front wheel at an angle to the left. To lock, turn the front wheel to the left, as the head lock key is turned 1/2 turn (180°), where steering becomes locked and wheel cannot be turned.

### NOTE

Make a record of key number so that it can be easily replaced in case of loss.

## Electric Starter

The starter button (8, figure 3) is located on the right handlebar. Push button to operate starting motor.

## Starter Crank

The starter crank pedal (15, figure 3) is located on the right side and has a spring return. To start the engine, kick the starter crank down with vigorous strokes to turn the engine over.

## Steering Damper (Special Equipment)

Steering damper is located directly over steering head. Turn steering damper adjusting knob clockwise to apply dampening action and counterclockwise to reduce dampening action. For solo riding, apply steering damper only when operating under conditions where some degree of dampening stabilizes steering. Sidecar users will find it advantageous to keep the damper set a little snug at all times.

## Horn

The horn is operated by the horn button (2, figure 3) on the left handlebar. Tone can be set as desired by turning the adjusting screw back of horn.

## Oil and Generator Signal Lights

In addition to the neutral indicator light described on page 9, there are two signal lights on the instrument panel. One is marked GEN and the

other is marked OIL. When the engine is running, both lights out indicate that the generator is charging normally and that oil is circulating normally. Trouble is indicated when one or both lights are on. Both lights will go on when the ignition-light switch is turned on before starting the engine. After the engine has started, both lights should go off except at slow idling speeds. The generator signal light will normally flash on and off at slow idle or at road speeds below 20 mph in high gear, because at these speeds generator output is very low and unsteady. If the generator signal light fails to go off at speeds above about 20 mph, the generator is either not charging at all, or its output is below normal and it should be inspected at once.

If the oil signal light fails to go off at speeds above idling, it is usually due to an empty oil tank or a diluted oil supply. In freezing weather the oil feed pipe may clog with ice and sludge, thus preventing circulation of the oil. A grounded oil signal switch wire, faulty signal switch, or trouble with the oil pump will also cause the light to stay on. If the oil signal light fails to go off, always check the oil supply first. Then, if oil supply is normal and the light still does not go out, look inside the oil tank and see if the oil returns to the tank from the outlet of

the oil return pipe when the engine is running. If it is returning to the tank there is some circulation, and you may drive slowly to the nearest Harley-Davidson dealer to have the oiling system checked and serviced, as needed. If no oil returns to the tank, stop the engine at once and do not drive farther until the trouble is located and the necessary repairs are made.

### **Adjustable Trail Front Fork (Special Equipment)**

This type fork is used on motorcycles intended for sidecar service. The forks are pivoted so that the wheel can be adjusted forward for less trail (in sidecar service), or the wheel can be adjusted rearward for more trail (in solo service). Normally, this fork is adjusted for solo service as shipped from the factory, and must be readjusted for sidecar service as follows:

1. Raise front end of motorcycle so front wheel is free. Underneath fork head lower bracket is a large bolt with castellated nut locked with a cotter pin. This bolt fastens lower fork bracket to fork stem bracket which has a slotted hole for the bolt. Remove cotter pin from nut and back off nut far enough so that lock plates underneath bolt head and

bolt nut can be disengaged from slots in each side of fork bracket. Now grasp front wheel and pull fork sides forward as far as elongated holes in bracket will permit. Re-engage lock plates in elongated holes with plate engaging to the front. Securely tighten nut and insert cotter pin.

2. Re-aim headlamp after fork is readjusted. (See page 51.)
3. For solo service, when sidecar is removed, move fork back by reversing above procedure.

### **Rear Shock Absorber Spring Adjustment**

The rear shock absorber springs can be adjusted to three positions for the weight the motorcycle is to carry. The average weight solo rider would use the extended spring position (off cam). A heavy solo rider might require the position with springs slightly compressed (first cam step); buddy seat riders require the fully compressed spring position (second cam step).

To adjust the rear shock absorber springs, turn cushion spring adjusting cam (figure 7) to desired position with spanner wrench. Both cushion spring adjusting cams must be adjusted to the same position. A spanner wrench for this purpose is available from your Harley-Davidson dealer.

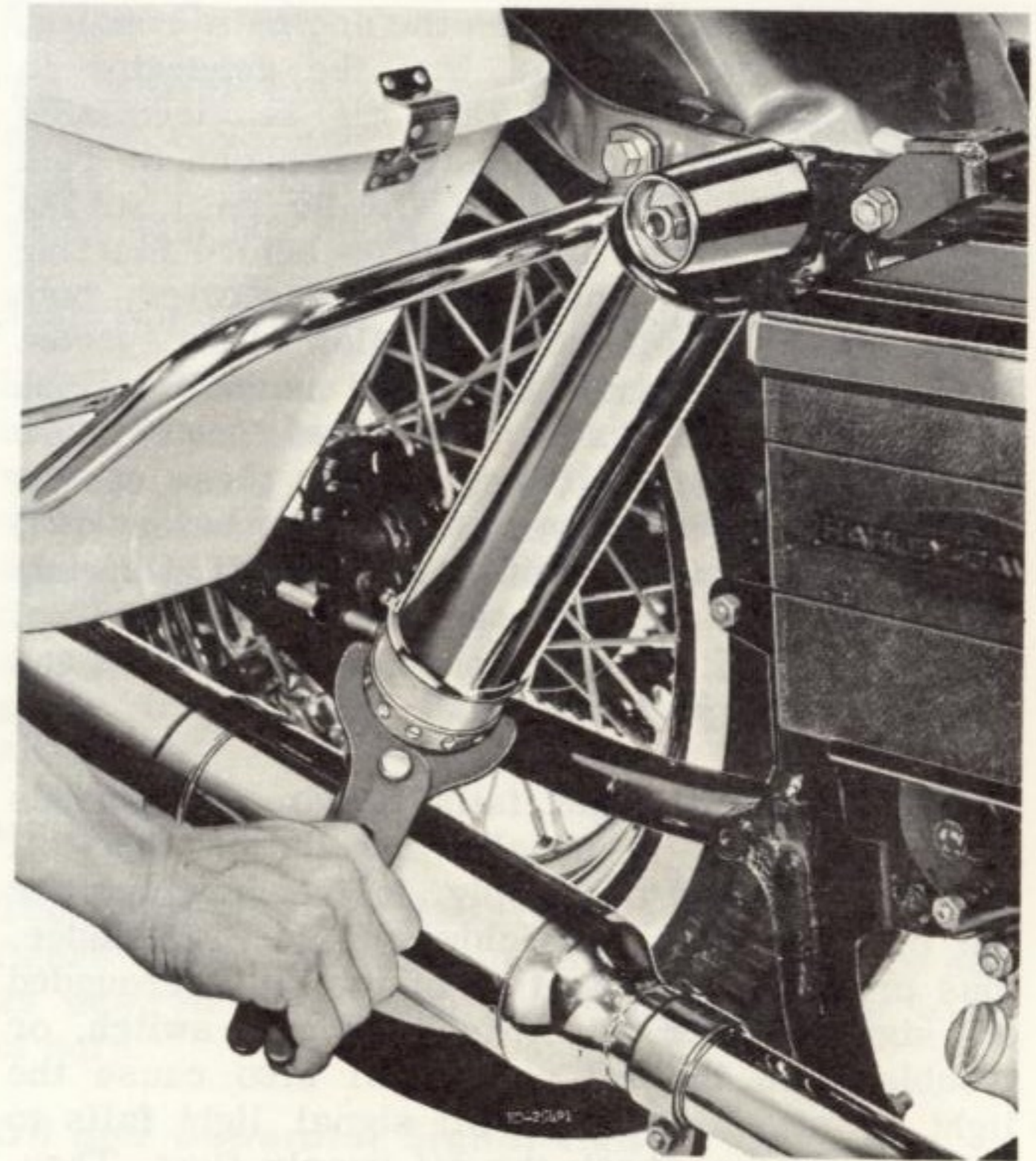

**FIGURE 7. REAR SHOCK ABSORBER  
SPRING ADJUSTMENT**

# RIDING

## The First 500 Miles

The sound design, quality materials, and workmanship that is built into your new Harley-Davidson will give you high performance right from the start.

However, for the first few hundred miles, to wear-in critical parts, observe the few simple driving rules below. This will guarantee future performance and durability.

1. During the first 50 miles, keep the speed below 45 miles per hour.
2. Up to 500 miles, vary the speed, avoiding any steady speed for long distances. Any speed up to the maximum legal limit is permissible for short distances.
3. Avoid fast starts at wide open throttle and over-speeding engine in lower gears. Drive slowly until engine warms up.

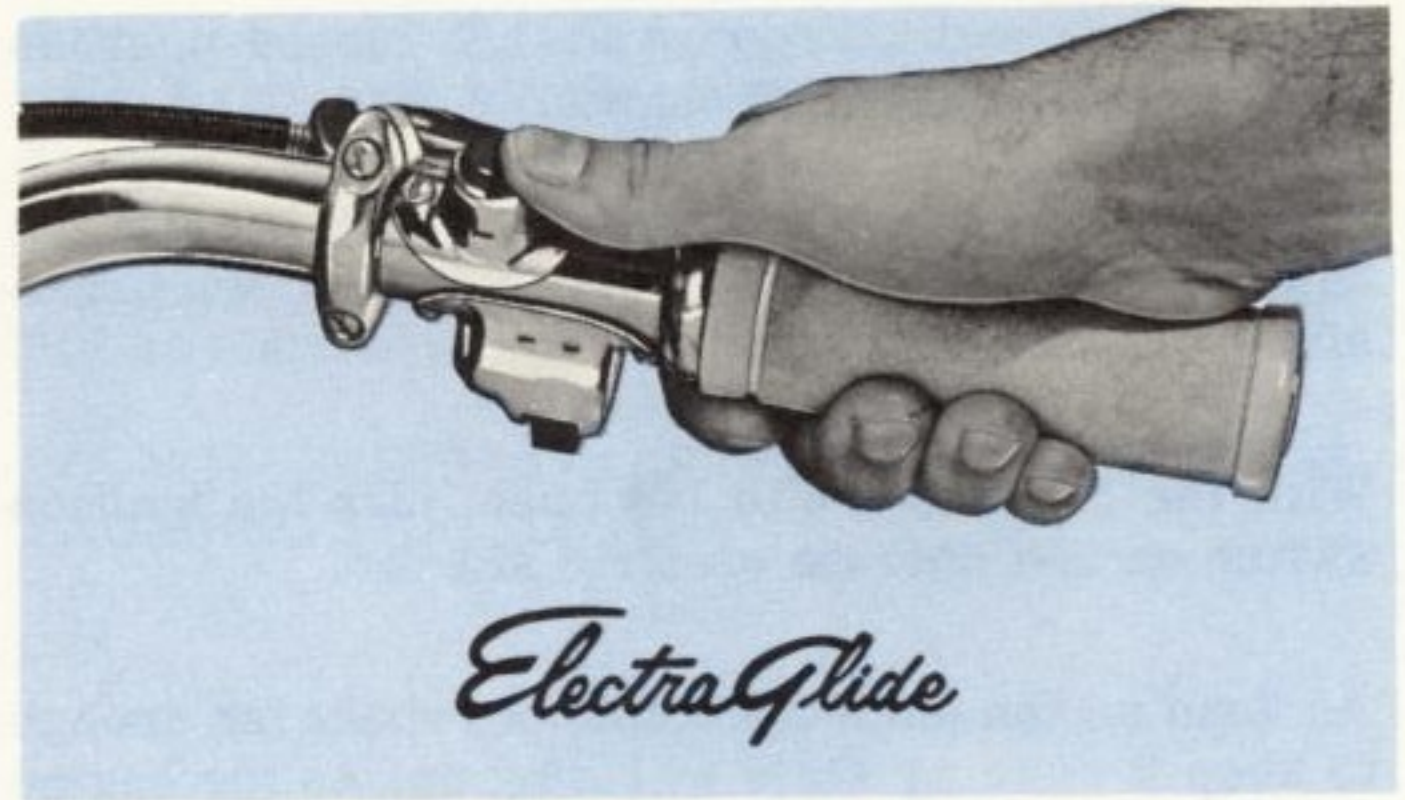

## Starting and Stopping Instructions

### IMPORTANT

Use recommended oil in relation to predominating temperatures. See engine lubrication, page 23.

When starting the engine determine that the motorcycle is in neutral and that the clutch is fully engaged.

### Electric Starter

In very cold weather, move choke lever (3, figure 1) up to the fully closed position before starting a cold engine.

Move the choke lever up to 1/2 closed position before starting a warm engine.

It is not necessary to use the choke to start a hot engine, that is an engine that is near normal running temperature.

With the throttle 1/8 to 1/4 open, turn the ignition switch on and operate electric starter.

As soon as the engine starts, open choke far enough to keep it running while warming up. As the engine warms up and misfires because of the over-rich mixture, gradually move the choke lever upward to fully open position.

#### NOTE

When the engine does not start after a few revolutions or if one cylinder fires weakly but engine does not start, it is usually because of an over-rich (flooded) condition. This is especially true of a hot engine. If the engine is flooded, open choke all the way, turn ignition on and operate starter with wide open throttle.

#### Kick Starter

Using the starter crank bring either cylinder to its compression stroke and follow through with a full stroke of the starter crank.

To start a cold engine in cold or warm weather, move choke lever (3, figure 2) up to the fully closed (prime) position. Open throttle full, and with ignition switch off, kick the starter pedal down twice to prime the cylinders. Then move choke lever down one notch in cold weather or two notches in warm weather. With the throttle nearly closed, turn the ignition switch on and start engine with a vigorous stroke of the starter pedal.

As soon as the engine starts, open the throttle just far enough to keep it running while warming up or until ready to set the motorcycle in motion. As the engine warms up and misfires because of the over-rich mixture, gradually move the choke lever downward to fully open position.

To start a warm engine, move the choke lever up to 1/2 closed position, set the throttle 1/4 open, turn on the ignition switch and start engine with vigorous strokes of the starter pedal.

To start a hot engine, that is, an engine that is near normal running temperature, it is not necessary to use the choke lever. With throttle 1/4 open, turn on ignition switch and kick the starter pedal down quickly. With some engines, depending on carburetor adjustment, hot starting is more dependable if the starter pedal is given one stroke before turning on ignition switch.

#### NOTE

When the engine does not start within 2 or 3 starting kicks, or if one cylinder fires weakly but engine does not start, it is usually because of an over-rich (flooded) condition. This is especially true of a hot engine. If the engine is flooded, turn off the ignition and crank the engine over 3 or 4 times with wide open throttle. This will clear the engine. Then follow correct starting technique as previously described for cold, warm or hot engine.

#### Operation

With motorcycle standing (engine stopped) proceed as follows to get under way. Determine that transmission is in neutral and clutch is fully engaged.

Start the engine, fully release the clutch, shift into first and slowly engage the clutch. After desired speed is attained in first, fully disengage the clutch, lift the foot lever all the way up to shift into second and again engage clutch. Shift in like manner for third and fourth gears.

**DO NOT SHIFT GEARS WITHOUT FULLY DISENGAGING THE CLUTCH.**

#### CAUTION

When the motorcycle is in motion and it is desired to shift to lower gears, do not shift from "third" to "second" until speed is reduced to 20 mph or less; do not shift from "second" to "first" until speed is reduced to below 10 mph. Shifting to lower gears when speeds are too high may result in damage to the transmission.

#### Stopping the Engine

Stop the engine by turning off the ignition switch. If the engine should be stalled or stopped in any other way than with the switch, turn off the switch at once to prevent battery discharge through the circuit breaker points.

## Operating Tips

Develop the habit of frequently snapping the throttle shut for an instant when running at high speed. This draws additional lubrication to pistons and cylinders and helps cooling.

In cold weather run engine slowly until it is thoroughly warmed up to avoid possible damage to pistons, rings, and other parts before oil is warm enough to circulate freely.

An engine which has run long distances at high speed, particularly in sidecar service, must be given closer than ordinary attention to avoid overheating and possible consequent damage. Have the engine checked regularly and keep it well tuned. Valve seating and good compression are particularly important. The carburetor should be adjusted moderately rich rather than lean. Inspect spark plugs often for good condition. This applies particularly to a motorcycle equipped with windshield.

Do not idle engine unnecessarily with motorcycle standing still. The spark plugs originally installed in the engine are of the proper heat range for most normal operating conditions. However, more severe than average service or very light service may call for a spark plug of a different heat range to prevent overheating, in the case of very severe

service or fouling in the case of very light service.

When plugs need to be replaced, get them from your Harley-Davidson dealer. He can supply you with the type of plug best suited to your requirements. Experimenting with plugs of unproven quality and suitability is inviting trouble.

## Locating Operating Troubles

The following check list of operating troubles and their probable causes will be helpful in keeping your motorcycle in good operating condition. Remember that more than one of these conditions may be causing the trouble and all should be carefully checked.

- ✓ If engine starts hard or runs unevenly or misses:
  1. Spark plugs in bad condition or have improper gap.
  2. Circuit breaker points out of adjustment or in need of cleaning.
  3. Condenser connection loose.
  4. Battery nearly discharged.
  5. Loose wire connection at one of battery terminals or at coil or circuit breaker.
  6. Water or dirt in fuel system and carburetor.

7. Gasline tank cap vent plugged and tank air bound.
8. Carburetor not adjusted correctly.
9. Engine and transmission oil too heavy (winter operation).

✓ If cranking motor does not operate:

1. Ignition switch is not on.
2. Transmission is not in neutral.
3. Discharged battery, or loose or corroded connections.
4. Starter control circuit or solenoid defective.

✓ If engine turns over but does not start:

1. Gasoline tank empty, valve shut off or gasoline line clogged.
2. Fouled spark plugs or shorted spark plug wires.
3. Circuit breaker points badly out of adjustment.
4. Loose wire connection at coil or circuit breaker.
5. Sticking valves or tappets set too tight.
6. Engine flooded as a result of overchoking.

✓ If a spark plug fouls repeatedly:

1. Too cold a plug for the kind of service.
2. Piston rings badly worn or in bad condition.

✓ If engine pre-ignites:

1. Excessive carbon on piston head or in combustion chamber.
2. Too hot a spark plug for the kind of service.
3. Defective spark plugs.

✓ If engine overheats:

1. Insufficient oil supply or oil not circulating.
2. Carburetor high speed adjustment too lean.
3. Ignition timing too late.

✓ If engine detonates:

1. Unsuitable fuel (octane rating too low).
2. Heavy deposit of carbon on piston and in combustion chamber.
3. Defective spark plug or of wrong heat range.
4. Ignition timing too early.

✓ If oil does not return to oil tank:

1. Oil tank empty.
2. Oil pump not functioning.

✓ If engine uses too much oil:

1. Piston rings badly worn or in bad condition.
2. One or more push rod cover cork washers in bad condition or a push rod cover not seating properly against its washer.
3. Chain oiler adjusted for excessive amount of oil.

✓ If vibration is excessive:

1. Cylinder bracket loose or broken.
2. Engine mounting bolts loose.
3. Transmission and/or transmission submounting plate loose.

✓ If generator does not charge or charging rate is below normal:

1. Brushes badly worn.
2. Brushes sticking in holders.
3. Commutator dirty or oily.
4. Loose or broken wire in generator-battery-regulator circuit.
5. Regulator not functioning properly.
6. Defective generator armature.
7. Broken field coil wire or loose terminal.

✓ If carburetor floods:

1. Float set too high.
2. Float valve and/or valve seat worn or damaged.
3. Dirt between float valve and its seat.

✓ If transmission shifts hard:

1. Bent shifter rod.
2. Clutch dragging slightly.
3. Transmission oil too heavy (winter operation).

✓ If transmission jumps out of gear:

1. Shifter rod improperly adjusted.
2. Shifter clutch dogs and/or dogs on its mating gear badly worn.

✓ If clutch slips:

1. Clutch controls improperly adjusted.
2. Insufficient clutch spring tension.
3. Friction discs oily.

✓ If clutch drags or does not release:

1. Clutch controls improperly adjusted.
2. Clutch spring tension too tight.
3. Friction discs gummy or oily.

✓ If brakes do not hold normally:

1. Brake improperly adjusted.
2. Brake controls binding as result of improper lubrication or damage.
3. Brake linings impregnated with grease as result of overgreasing wheel hub.
4. Brake linings badly worn.
5. Hydraulic system contains air or master cylinder reservoir low on hydraulic brake fluid.
6. Leak in hydraulic system.

## RULES OF THE ROAD

1. Keep on the right side of the road when meeting other vehicles coming in the opposite direction.
2. Always sound your horn and pass on the left side when passing other vehicles going in the same direction. Never try to pass another vehicle going in the same direction at street intersections, on curves, or when going up or down a hill.
3. At street intersections give the right-of-way to the vehicle on your right. Do not presume too much when you have the right-of-way; the other driver may not know you have it.
4. Always signal when preparing to stop, start, or turn.
5. All traffic signs, including those used for the control of traffic at intersections, should be obeyed promptly and to the letter. "Slow Down" signs near schools and caution signs at railroad crossings should always be observed and your actions governed accordingly.
6. Never "crash" a light. When a change is indicated from "Go" to "Stop" (or vice versa) in the traffic control systems at intersections, await the change.
7. When intending to turn to the left, give signal at least 100 feet before reaching the turning point. Move over to the center line of the street (unless local rules require otherwise), slow down passing the intersection of the street and then turn carefully to the left.
8. In turning either right or left, watch for pedestrians as well as vehicles.
9. Do not leave the curb or parking area without signaling and seeing that your way is clear to drive into moving traffic. A moving line of traffic has the right-of-way.
10. See that your license tags are installed in the position specified by law and that they are clearly visible under all conditions. Keep them clean.
11. Ride at a safe speed - a speed consistent with the type of highway you are on, and always note whether the road is dry or wet. Each varying condition on the highway means adjusting your speed accordingly.

# SERVICING

## New Motorcycle Initial Service

After a new motorcycle has been driven its first 500 miles and again at approximately 1000 miles, the motorcycle should be taken to the dealer from whom it was purchased for certain initial service operations with which the dealer is familiar. If it is impossible to take the motorcycle to a dealer at the mileage intervals mentioned, the owner should at least give the following outlined attention, or arrange to have it given, and take the motorcycle to the dealer for more complete servicing later on when convenient to do so.

### CHECK AT FIRST 500 MILES

1. Drain oil tank through drain plug (6, figure 2) flush tank and refill with fresh oil.
2. Clean oil filter.
3. Drain transmission through drain plug and refill to level of filler opening with fresh oil. Use same grade oil used in engine.

4. Lubricate all points indicated for 2000 mile attention in the SERVICE AND MAINTENANCE CHART.
5. Aim headlight.
6. Check front fork bearing adjustment.
7. Clean carburetor gas strainer.
8. Clean chain housing magnetic drain plug.
9. Inspect and clean spark plugs.
10. Check ignition timing and circuit breaker point gap.
11. Oil all control joints and parts indicated for 2000 mile attention.
12. Inspect and service air cleaner if needed.
13. Check adjustment of chains and readjust if necessary.
14. Check lubrication of chains.
15. Check all nuts, bolts and screws, and tighten any found loose.
16. Check wheel mounting socket bolts and tighten if needed. These bolts must be kept very tight.
17. Check and tighten wheel spokes.

18. Check level of solution in battery and add distilled water if needed. See that terminals are clean and connections tight.
19. Check tightness of all cylinder head bolts and all cylinder base nuts, and tighten where necessary.
20. Check brake adjustment and hydraulic fluid level.
21. Check clutch adjustment.
22. Check tire pressure and inspect tread.
23. Road test.

### **CHECK AT FIRST 1000 MILES**

1. Drain oil tank and refill with fresh oil.
2. Clean oil filter.
3. Check level of oil in transmission and add oil if needed. Use same grade of oil used in engine.
4. Service air cleaner.
5. Check circuit breaker point gap.
6. Check adjustment of chains and adjust if necessary.
7. Check lubrication of chains.

8. Check level of solution in battery, and add distilled water if needed. See that terminals are clean and connections tight.
9. Check brake adjustment and hydraulic fluid level.
10. Check clutch adjustment.
11. Check tire pressure and inspect tread.
12. Road test.

### **Regular Service Intervals**

Regular motorcycle lubrication and maintenance will help you keep your new Harley-Davidson operating at peak performance, and will give you lower operating costs, longer motorcycle life, and greater riding pleasure. Your Harley-Davidson dealer knows best how to service your motorcycle with factory approved methods and equipment assuring you of thorough and competent workmanship for every job.

The chart on page 22 shows the regular intervals at which specified service operations should be performed. For more detailed description of the service and maintenance procedures specified, refer to information following after chart.

## SERVICE AND MAINTENANCE CHART

REGULAR SERVICE INTERVAL	ENGINE OIL	TRANSMISSION OIL	GREASE	OIL	SERVICE
EVERY 300 MILES	CHECK				
EVERY 1000 MILES	CHECK	CHECK		Rear Chain	Air Cleaner Battery Rear Chain Adjustment Hydraulic Brake Fluid
EVERY 2000 MILES	CHANGE		Rear Fork Pivot Bearing Fitting Seat Post Saddle Bar Bearing Rear Brake Pedal Bearing Foot Shift Lever Bearing Hand Clutch Booster Bearing Front Wheel Hub Thrust Bearing Rear Wheel Hub Thrust Bearing Foot Clutch Pedal Bearing	Clutch Hand Lever Brake Hand Lever Clutch Control Cable Front Brake Cable Throttle Control Cable Clutch Lever Rod Clevis Shifter Control Joints	Oil Filter Gasoline Strainer Front Chain Adjustment Rear Chain Oiler Brake Adjustment Circuit Breaker Clutch Adjustment
EVERY 5000 MILES OR 1 YEAR whichever comes first		CHANGE	Speedometer and Tachometer Cables Throttle Control Spiral Front Wheel Hub (Center) Rear Wheel Hub (Center) Sidecar Wheel Hub (Center)		Generator Replace: Spark Plugs Oil Filter Time Ignition Switch Tires Check Front and Rear Fork Bearing Adjustment
WEEKLY					Check Tires Check Battery
SPRING AND FALL	CHANGE	CHANGE			

# ENGINE

## Lubrication

Use Harley-Davidson Oil	Grade	Predominating Temperature (° F.)
Regular Heavy	105	75 or above
Medium Heavy	75	75 to 32
Special Light	58	32 or below

Your Harley-Davidson dealer will have the correct oil for your requirements.

The oil tank capacity is 4 quarts and is considered full when the oil level is up to "FULL" mark on gage rod. Do not fill above this level, as the tank needs some air space. Tighten the cap securely to prevent leakage. The oil signal light in the center of the instrument panel indicates oil circulation (see page 10). Oil mileage normally varies from 250 to 500 miles per quart depending on the nature of service, solo or sidecar, fast or moderate driving, and how well the engine is kept tuned. If mileage is not within this range, see your dealer.

REMOVE TANK CAP AND CHECK OIL SUPPLY NOT MORE THAN 300 MILES AFTER EACH COMPLETE REFILL. If oil level is found near "ADD" mark or gauge rod, add one quart. When level is down to "DANGER" mark, two quarts should be added.

### CAUTION

Do not allow oil level to go below the "DANGER" mark on gauge rod.

Oil will run cooler and mileage will be somewhat higher with oil level well up in tank. Furthermore, unless oil tank is kept well filled, frequent checking of oil level will be necessary to avoid any chance of running dry.

Oil should be changed after the first 500 miles and 1000 miles for a new engine, and thereafter at about 2000 mile intervals in normal service at warm or moderate temperatures. Oil change intervals should be shorter in cold weather — See "Winter Lubrication." Completely drain oil tank of used oil and refill with fresh oil. If service is extremely hard or on dusty roads or in competition, drain and refill at shorter intervals.

Draining should be done after a run while oil is hot. It is not necessary to drain the crankcase as it does not accumulate used oil. At the time of the first 500 mile oil change, and along with at least every second oil change thereafter, thoroughly flush and clean out tank with kerosene to remove any sediment and sludge that may have accumulated. Your dealer has facilities for quick flushing and cleaning of oil tank.

### **Oil Filter**

Oil filter is located in the oil tank below filler cap. To service the filter, remove it from oil tank, remove retaining spring from top of filter and disassemble. Thoroughly wash the filter element in clean gasoline or solvent at least once every 2,000 miles when the engine oil is changed.

Renew filter element every 5,000 miles.

### **Winter Lubrication**

Combustion in any engine generates water vapor. When starting and warming up in cold weather, much of the vapor condenses to water on relatively cool metal surfaces. If engine is driven enough

to get the crankcase thoroughly warmed up, frequently, most of this water is again vaporized and blown out through the breather. However, a moderately driven engine, making only short runs now and then and seldom being thoroughly warmed up, is likely to accumulate an increasing amount of water in the oil tank. This water will, in freezing weather, become slush or ice and if allowed to accumulate too long, will block oil lines and damage the engine. Also, water mixed with oil for some time forms sludge that is harmful to the engine and causes undue wear of various working parts. Therefore, in winter the oil change interval should be shorter than normal for all engines, and any engine used only for short runs, particularly in commercial service, must have oil changed frequently along with a thorough tank flushout to remove any water and sludge, before new oil is put in tank. The farther below freezing the temperature drops, the shorter the oil change interval should be.

### **Air Cleaner**

**METAL MESH TYPE FILTER ELEMENT:** In normal service on hard surfaced roads, remove air cleaner mesh, wash in gasoline, and saturate

with engine oil at least every 1000 miles, or oftener under dusty service conditions. In extremely dusty service, clean and oil filter mesh every 100 miles or at least once a day.

**DRY CORRUGATED TYPE FILTER ELEMENT:**  
In normal service on hard surfaced roads, remove air cleaner cartridge every 1000 miles, and shake cartridge by tapping lightly to remove loose dirt. If surfaces of element are oily or sooted, wash in gasoline. Since in time the element becomes plugged with dirt, the cartridge should be replaced at least every 5000 miles. In extremely dusty service, both cleaning and cartridge replacement should be done more often.

### **Gasoline Strainer**

The gasoline strainer is located on top of the gasoline supply valve inside the gasoline tank (see figure 4). If the supply of gasoline is impeded, as indicated by irregular carburetion, remove the gasoline supply valve from the tank and thoroughly clean the gasoline strainer. Be sure to drain the tank before removing the gasoline supply valve.

## **TRANSMISSION AND CHAINS**

### **Transmission**

Use same grade of oil used in engine.

Remove transmission oil filler plug (13, figure 1) and check oil level every month or every 1000 miles, whichever comes first. Add oil if necessary and fill to the level of the filler opening. The motorcycle should be standing **STRAIGHT UP**, not leaning on jiffy stand, when adding oil to the transmission. Drain transmission and refill to correct level with fresh, clean oil after the first 500 miles, and thereafter seasonally or every 5,000 miles, whichever comes first. If transmission should become submerged in water, drain it immediately and refill to proper level.

### **Chains**

#### **Front Chain**

A fixed amount of oil is supplied through an oil line from a metering orifice in the oil pump. Oil drops on front chain from oiler outlet tube (10, figure 12). Excess oil collects at rear of chain compartment and is drawn back into engine gear case breather.

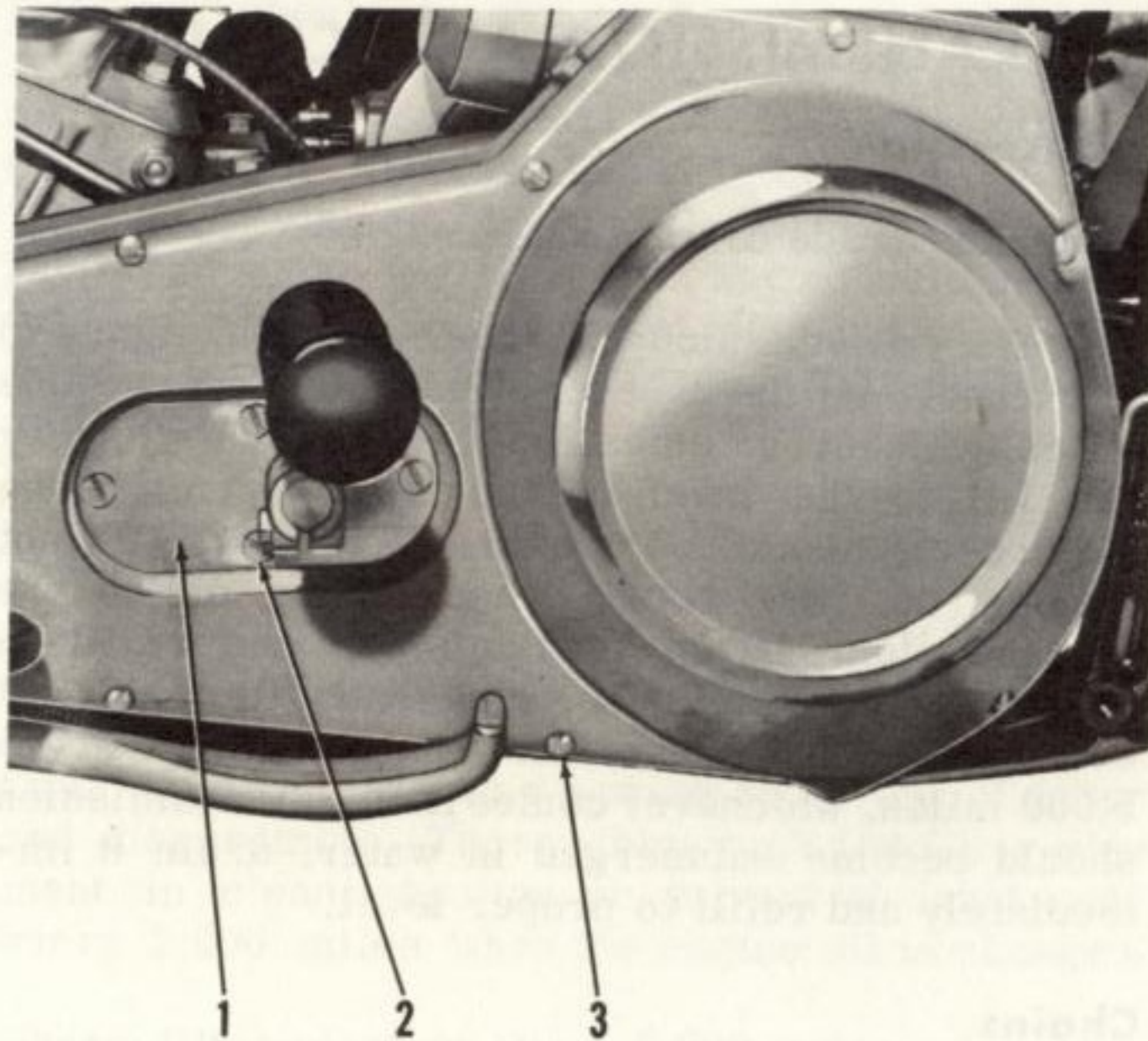

1. Chain Inspection Cover
2. Inspection Cover Screws (4)
3. Chain Housing Cover Screws (8)

FIGURE 8. CHAIN INSPECTION COVER

When the front chain adjustment is checked at 2000 mile intervals (see page 43), also check to see that oil comes out of oiler tube when engine is running, when viewing through cover inspection hole (1, figure 8). If oil does not come from oiler, supply orifice at pump is probably blocked due to accumulation of dirt, and requires cleaning. To do this, remove orifice screw and washer from oil pump and blow out passage to chain compartment with compressed air.

### Rear Chain

Under normal operating conditions brush the dirt off and lubricate the rear chain at 1000 mile intervals. Lubricate with Harley-Davidson "Chain Saver," "Chain Spray" or "Chain Grease" if available; if not available, use lightest engine oil available.

If motorcycle is equipped with rear chain oiler, disregard above instructions and proceed as follows: At regular 2000 mile intervals, make a close inspection of rear chain. If rear chain does not appear to be getting sufficient lubrication, or if there is evidence of an over-supply of oil, readjustment should be made with rear chain

oiler adjusting screw. The rear chain oiler is located on the oil return line. Normal setting is 1/4 turn open which provides 2 or 3 drops per minute. If oilers should become blocked, remove screw and clean orifice.

If the motorcycle is operated under extremely dusty or dirty conditions, whether equipped with a rear chain oiler or not, additional lubrication of the rear chain may be advisable from time to time. Under these conditions proceed as follows: Remove chain from motorcycle. Soak and wash it thoroughly in a pan of kerosene. Remove chain from kerosene and hang it up for a time to allow kerosene to drain off. Immerse for a short time in a pan of grease heated to consistency of light engine oil. If grease and facilities for heating are not at hand, substitute light engine oil. While immersed, move chain around to be sure that hot grease or oil works through all inside parts. After removing from hot grease or oil, allow chain to drain and wipe all surplus grease or oil from surface of chain. Install chain on motorcycle. Inspect connecting link and spring clip closely for bad condition. Replace if at all questionable. Be sure spring clip is properly and securely locked on pin ends.

## CHASSIS

### Greasing

Use Harley-Davidson "Grease All" for greasing requirements.

All chassis bearings requiring frequent applications of grease are provided with grease gun fittings. Locations and recommended greasing intervals are listed in the SERVICE AND MAINTENANCE CHART (Page 22).

Be careful about over-greasing wheel hubs. Excess grease working out of these bearings produces a messy condition and is likely to get onto brake linings and greatly reduce efficiency of brakes. Using hand grease gun will help prevent over-greasing.

Remove and grease handlebar throttle grip spiral with fresh grease every 5,000 miles, or when operation of grip indicates lubrication is necessary.

Remove and grease speedometer and tachometer drive cables every 5000 miles.

On models having grease fitting on rear fork pivot bearing housing, apply a very small quantity of

grease (one stroke of grease gun) to fitting at 2000 mile intervals with hand grease gun.

### CAUTION

Over-greasing will damage seals.

Pack the steering head bearings with fresh grease at 50,000 miles.

### Oil Applications

All control connections and parts as indicated in the SERVICE AND MAINTENANCE CHART (Page 22) should be oiled regularly, particularly after washing motorcycle or driving in wet weather.

### Generator Bearings

Generator commutator end roller bearing is packed with grease and sealed, and normally does not need additional grease.

Generator drive end ball bearing requires no attention as it is lubricated by the oil that circulates through the engine.

### Hydra-Glide Fork

The Hydra-Glide fork requires very little maintenance or attention. It requires no greasing. If fork does not appear to be working properly, or an appreciable amount of oil leakage should develop, attention should be given by an authorized Harley-Davidson dealer.

Incorrect recoil action will result if there is insufficient oil in either side of the fork. To check the amount, completely drain the oil and then pour back into each side 6-1/2 to 7 ounces of Harley-Davidson Hydraulic Fork Oil. Oil drained from the fork may be used again provided it does not appear to be contaminated by water or other foreign matter. Add only enough fresh oil to provide the required amount.

If fork should at any time become submerged in water, drain and refill immediately.

In an emergency, when Harley-Davidson Hydraulic Fork Oil is not available, use the lightest automobile engine oil obtainable. Do not use shock-absorber fluid. If engine oil is used, however, drain and replace with Hydraulic Fork Oil as soon

as possible. The consistency of engine oil varies with temperature changes, and stiff recoil action and a rough ride will result at lower temperatures. Temperature changes have little effect on the recommended oil.

To drain and refill fork, remove headlamp and headlamp housing, then remove the hex head cap screw at the top of each fork side. Remove the drain plug at the lower end of each slider with a 3/16 inch Allen wrench, and drain the oil into a clean container. Add oil to container, if necessary, to make up the required amount. Replace the drain plugs and add 6-1/2 to 7 ounces of oil through the hole in the upper end of each fork tube. Then install the cap screw and tighten securely.

Filling the fork using only a funnel is a rather slow job because the filler openings in the fork are small and the filler channel tends to become air locked. It is recommended that you see your Harley-Davidson dealer when this service is required, as he has the necessary equipment to do the job cleanly and quickly.

The adjustable trail Hydra-Glide Fork (special equipment for sidecar service) does not have a

hex head cap screw at the top of each fork side, but has oil filler plugs at the rear of each fork side which can be removed with a large screwdriver.

### Hydraulic Brake

Every 1000 miles, check fluid level in master cylinder (8, figure 1) located just ahead of rear brake foot pedal. When removing filler plug, be sure that all dirt is removed from around filler plug to prevent entrance into reservoir. Level should be 1/4 inch from top of cover. Use only HYDRAULIC BRAKE FLUID, which is approved for use in hydraulic brake systems.

### Battery

It is the care given a battery, rather than time and miles of service, which is most important in determining its life.

### Solution

Inspect the level of the battery solution at least once a week during motorcycle operation, adding pure distilled water as often as necessary to

keep the solution above the plates. If the motorcycle is not used for an extended period of time, check solution level before placing in service.

Remove battery cover and take out 6 screw end filler plugs. With a hydrometer or syringe, add water to each cell to raise level of solution up to triangle or circle at base of filler hole.

#### NOTE

If battery is filled to a higher level, some of the solution will be forced out through the vent holes when battery is charging. This will not only weaken the solution, but also may damage parts near the battery. Avoid getting battery acid on clothing or other fabrics. Keep battery clean and terminal connections tight.

#### Charging

Check solution in each cell with a battery hydrometer. If hydrometer reading is below 1.200, remove battery and charge it from an outside source. The charging current should be 12 volt direct current and charging rate should not be allowed to go over 4 amperes.

A higher battery charge rate may heat and damage the battery. For this reason, do not allow the motorcycle battery to be charged in the same line with auto batteries. Hydrometer reading of fully charged battery in good condition will be from 1.265 to 1.300.

Allowing battery to remain in a discharged condition for any length of time shortens its life. It is especially important that the battery be kept well charged in below freezing weather. A low or discharged battery is very likely to be frozen and ruined.

#### Keep the Motorcycle Clean

Keeping the motorcycle clean on the outside as well as on the inside not only is a sign of good maintenance, it is good maintenance. To aid you in keeping your motorcycle clean see your Harley-Davidson dealer for the following:

#### Harley-Davidson "Gunk"

Harley-Davidson "Gunk" will quickly and efficiently remove grease and oil from the metal parts of your motorcycle leaving a clear bright finish.

## IMPORTANT

Do not allow "Gunk" cleaner to come in contact with seat or saddlebag material since it may cause discoloration. Use mild soap and water to clean these materials.

### Harley-Davidson "Chrome Cleaner"

Use Harley-Davidson "Chrome Cleaner" to make the chrome parts of your motorcycle glitter and sparkle.

### Harley-Davidson "Polish and Cleaner"

Harley-Davidson "Polish and Cleaner" is made to clean and polish the enamel parts and to maintain or restore these parts as close as possible to their original luster.

### Harley-Davidson "Plastic Cleaner"

Harley-Davidson Plastic Cleaner, Part No. 98680-64 is recommended for cleaning of vinyl plastic seats. Cleaner comes in 15 oz. spray can. To use, spray on and allow to set for a few seconds. Then wipe clean with a damp cloth or sponge. Full instructions appear on the can.

## MAINTENANCE

To obtain the longest possible life and the best possible performance from your motorcycle it is necessary not only to keep it adequately serviced, but also correctly adjusted to the tolerances to which it was manufactured. The following are the adjustments and general maintenance facts pertaining to your motorcycle.

## ENGINE

### Spark Plugs

Keep plugs clean and the gap between the electrodes adjusted to .025 inch to .030 inch. Clean with a sand blast cleaner.

Be sure your motorcycle is operating with the correct heat range plug best suited to your type of riding. If in doubt see your Harley-Davidson dealer. It is recommended that new plugs are installed every 5000 miles.

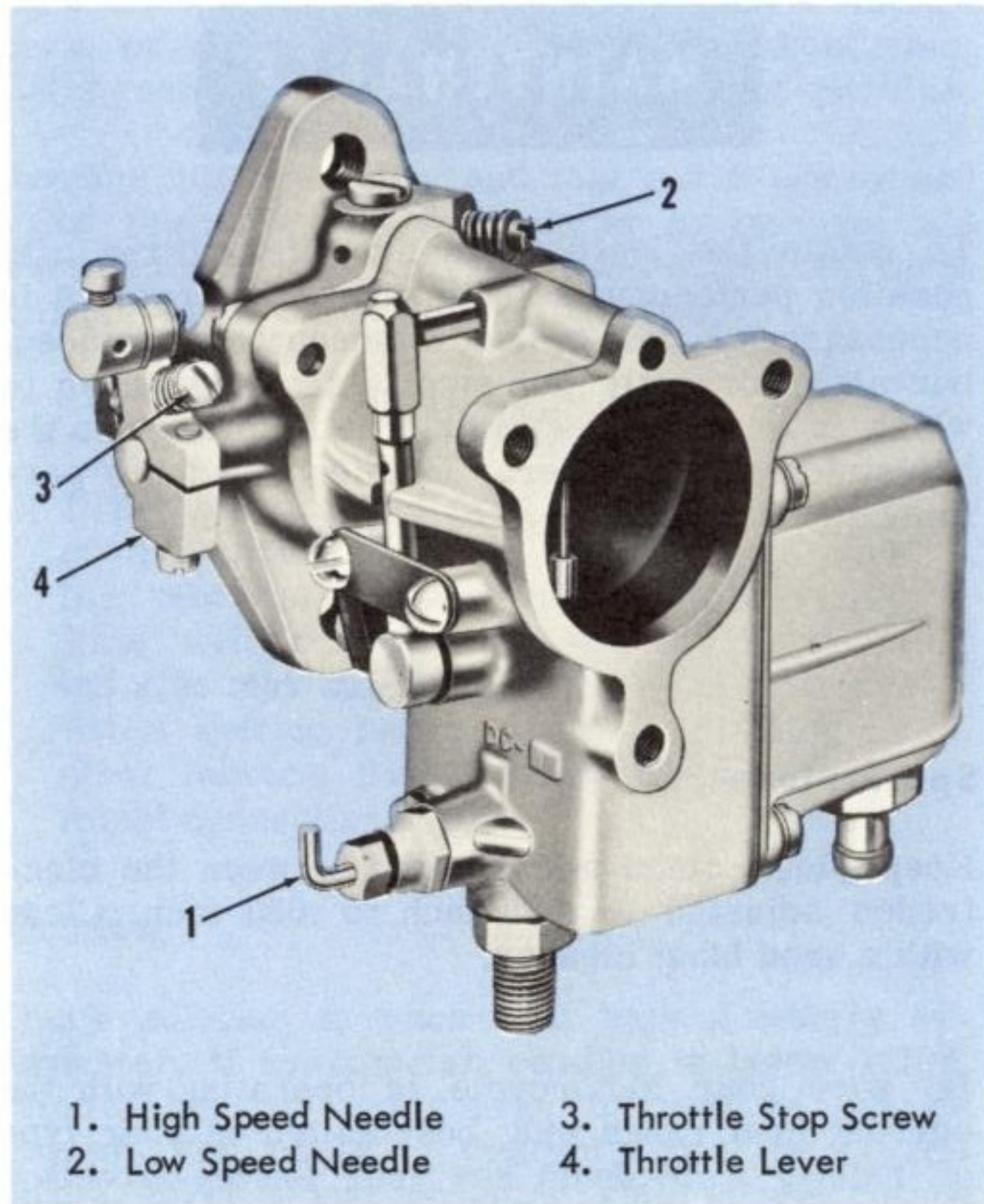

- |                      |                        |
|----------------------|------------------------|
| 1. High Speed Needle | 3. Throttle Stop Screw |
| 2. Low Speed Needle  | 4. Throttle Lever      |

**FIGURE 9. CARBURETOR**

### **Carburetor Adjustment (see figure 9)**

A carburetor, once properly adjusted, requires little, if any, readjustment. It should not be necessary to adjust the needles more than a fraction of a turn richer or leaner, to correct mixture for a change in weather conditions. Do not continually tamper with carburetor adjustments. If engine does not start and run right, look for trouble elsewhere before checking the carburetor.

We suggest that carburetor adjustments be made by your Harley-Davidson dealer.

The fuel supply for low speed is completely regulated by the low speed needle. The fuel supply for high speed is regulated by a combination fixed jet and adjustable needle. The fixed jet dominates the regulation of high speed fuel supply. The high speed needle provides a means of supplementing, to a limited degree, the fuel supplied by the fixed jet, when it is found that enriching the mixture slightly improves engine performance.

Both the high speed needle (1) and low speed needle (2) turn down (to right) to make mixture leaner at the respective speeds for which they adjust. Backing them out (to left) makes mixture richer. Closed throttle idling speed of engine is adjusted with throttle stop screw (3).

A carburetor that is badly out of adjustment may be readjusted as follows:

1. Make sure carburetor control wire is adjusted so throttle lever (4) fully closes and opens with handle bar grip movement.
2. Turn both the high speed needle (1) and the low speed needle (2) all the way in (to right). Do not close off either needle too tightly or damage to needle and seat may result.
3. Back up (to left) low speed needle (2) about 1-1/2 turns. With needle in this position, engine will start, but low speed mixture will probably be too rich.
4. Start the engine and after it has reached operating temperature and the choke has been moved to the open position, adjust throttle control to idle speed.
5. Turn low speed needle (2) in (to right) slowly until mixture becomes so lean that engine misses and is inclined to stop; then, slowly back needle out (to left) until engine hits regularly with engine running at idle speed. Starting and all around carburetion will be better with low speed adjustment slightly rich, rather than as lean as it can be made.
6. Adjust throttle lever stop screw (3) as necessary, to make engine idle at proper speed with throttle fully closed. Turn screw to right to make engine idle faster and to left to make engine idle slower. Do not idle an engine at the slowest possible speed because an extremely slow idling adjustment causes hard starting. Changing the idle speed with throttle stop screw is likely to change the low speed mixture slightly. It will, therefore, be necessary to again check and correct low speed needle adjustment by the same procedure followed in making the initial adjustment.
7. Check high speed adjustment, after low speed adjustments have been completed. Run motorcycle on the road at various speeds between 20 miles per hour and maximum speed. Have spark fully advanced. Best all around engine performance can usually be found with the high speed needle (1) set from 3/4 to 1-1/4 turns open.

### **Circuit Breaker (see figure 10)**

Circuit breaker points should be checked for gap and contact surface condition initially at 500 and 1000 miles, and thereafter every 2000 miles.

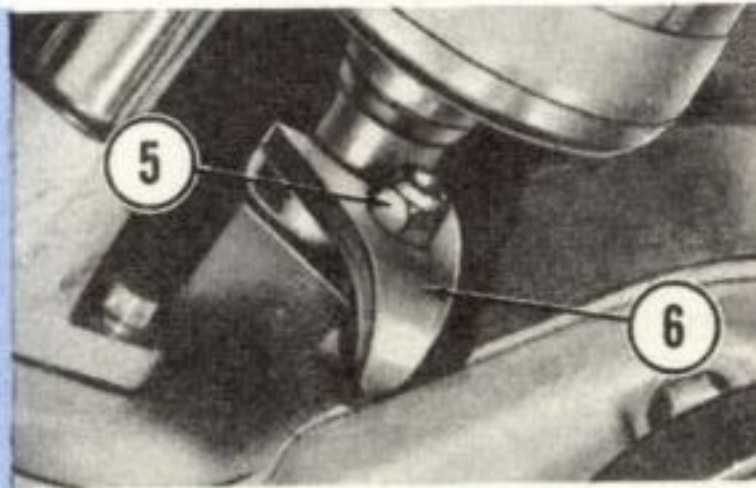
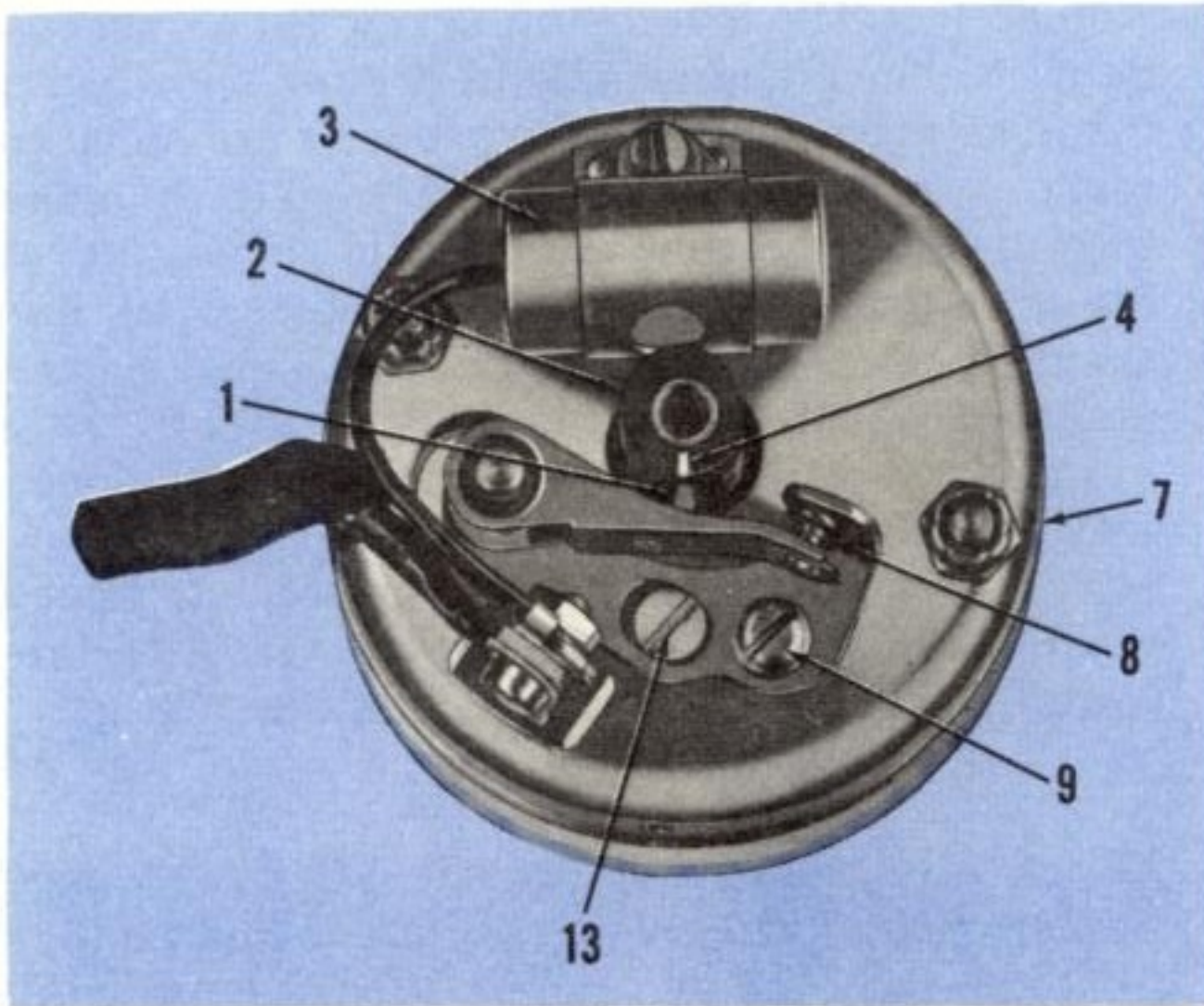

1. Fiber Cam Follower
2. Breaker Cam
3. Condenser
4. Cam Timing Mark
5. Circuit Breaker Clamp Nut
6. Circuit Breaker Clamp
7. Circuit Breaker Head
8. Contact Points
9. Adjustable Point Lock Screw
10. Timing Inspection Hole
11. Retard ( $5^{\circ}$ ) Timing Mark on Flywheel
12. Advance ( $35^{\circ}$ ) Timing Mark on Flywheel
13. Eccentric Adjusting Screw

TIMING POSITION OF FLYWHEEL TIMING MARKS (ON LEFT SIDE OF ENGINE)

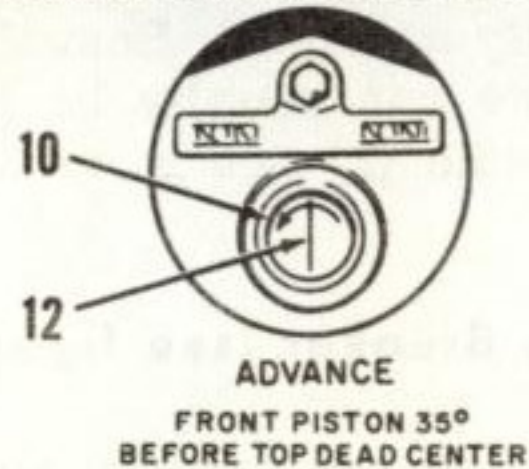
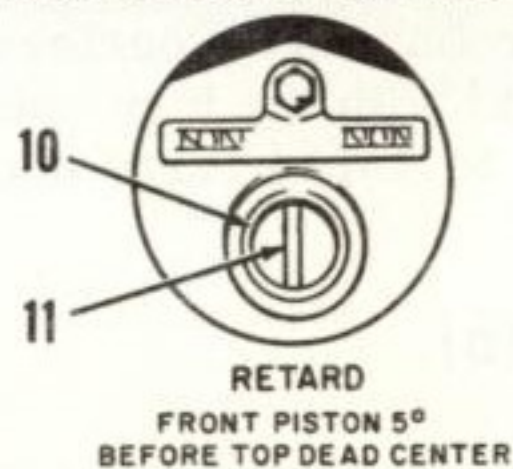

FIGURE 10. CIRCUIT BREAKER AND TIMING MARKS

Check the gap between the contact points (8) with a 0.022 inch gage (wire preferred). If it is not exactly 0.022 inch when the cam follower (1) is on either of the highest points of cam (2), adjustment is necessary. Incorrect point gap spacing affects ignition timing. To adjust the points, loosen the lock screw (9) and move the eccentric adjusting screw (13) to provide a contact point gap of 0.022 inch. Retighten the lock screw (9) and again check the gap to make sure it remains correct. Points in pitted or worn condition should be replaced.

### **Ignition Timing (see figure 10)**

Ignition timing is controlled by the circuit breaker. Correct ignition timing and correct setting of the circuit breaker contact point gap is absolutely necessary for proper engine operation and performance.

The spark timing cam is advanced automatically as engine speed increases through action of the flyweights in the circuit breaker base. This insures correct spark timing to suit both starting and running requirements.

To check or reset ignition timing, proceed as follows:

Remove spark plugs to permit engine to turn easily; remove screw plug from timing inspection hole (10) in left side of crankcase. Then remove front push rod cover so that opening and closing of valve can be observed. Remove circuit breaker cover and set circuit breaker contact gap at exactly 0.022 inch as outlined under CIRCUIT BREAKER.

Turn engine in direction in which it runs until front piston is on compression stroke (just after front intake valve closes), and continue turning engine very slowly (less than 1/2 revolution) until retard timing mark (11) on flywheel is aligned in the inspection hole (10), as shown in figure 9.

Timing mark (4) on top edge of circuit breaker cam (2) should now align with breaker arm fiber cam follower (1). If it does not, loosen circuit breaker clamp nut (5) and shift circuit breaker head (7) clockwise (retard) or counterclockwise (advance) to attain alignment.

Be sure cam is rotated counterclockwise on shaft as far as it will go when checking alignment. Retighten clamp nut (5) when alignment is obtained. (This procedure will result in approximate timing and engine can be operated in an emergency for a short period until either of the two following accurate timing procedures can be followed.)

### **Checking Timing With Circuit Tester (Retarded Position)**

Timing mark (4) on cam is the approximate point at which contacts (8) open and front cylinder ignition spark occurs. When the wide cam lobe opens the points, rear cylinder ignition spark occurs. To accurately check and set timing, connect a circuit tester such as a light bulb across the contact points to determine the exact point of contact opening. Loosen circuit breaker clamp nut just enough to shift circuit breaker head (7) so contacts will open exactly when flywheel retarded timing mark (11) is aligned in center of inspection hole (10), shown in figure 10. Tighten clamp nut and recheck timing by slowly rotating flywheels in direction of engine operation. Contacts should open exactly when retarded timing mark comes into center of timing hole. Timing

will advance  $30^{\circ}$  automatically when engine is operated above cranking speed.

### **Checking Timing With Strobe Timing Light (Advanced Position)**

A strobe flash timing light is used to view advanced timing mark (12) on flywheel through accessory plastic view plug screwed into timing inspection hole (10) while engine is running between 1500 and 2000 RPM. Timing light leads should be connected to front spark plug and ground. Light will flash each time front cylinder spark occurs. Loosen circuit breaker clamp nut just enough so circuit breaker head (7) can be shifted as light aimed into inspection hole (10) stops timing mark (12) in center of hole, shown in figure 10. Timing will retard  $30^{\circ}$  automatically when engine is stopped.

At regular intervals of 5000 miles or at least once a year, have your dealer check ignition timing and, if necessary, readjust circuit breaker setting to compensate for wear on circuit breaker and timing gears that may have caused a slight change in timing.

## Hydraulic Tappets

Tappets are self-adjusting, hydraulic type. They automatically adjust length to compensate for engine expansion and valve mechanism wear, and thus keep the valve mechanism free of lash when the engine is running. Tappet adjustment is required only in a new engine assembly and when the engine is reassembled after repair. No further readjustment of tappets is required.

When starting an engine which has been shut off even for a few minutes, the valve mechanism may tend to be slightly noisy until the hydraulic units completely refill with oil. If at any time, other than for a short period immediately after engine is started, valve mechanism becomes abnormally noisy, it is an indication that one or more of the hydraulic units may not be functioning properly. Always check the lubricating oil supply in the oil tank first if the valve mechanism is noisy, since normal circulation of oil through the engine is necessary for proper operation of the hydraulic units. If there is oil in the tank, the units may not be functioning properly due to contamination of the oil supply. Drive at moderate speed to the nearest Harley-Davidson dealer for further attention.

## TRANSMISSION

The need of attention to clutch and controls will be indicated by the clutch slipping under load or dragging in released position. In either case, the first thing to be checked is the adjustment of controls.

### Clutch Hand Control

Normally the only attention the clutch hand control requires is occasional readjustment of control coil adjusting sleeve (1, figure 11) and clutch lever rod (13, figure 11) to maintain the correct amount of free movement for hand lever on handlebar and clutch actuating lever on transmission.

Should the need of major readjustment be indicated by such malfunctioning as hand lever becoming extremely hard to operate; clutch control booster bellcrank failing to return to forward position when hand lever is released; slipping clutch; or dragging clutch indicated by excessive gear clash

when shifting, the following adjustments should be made in the order indicated:

**NOTE**

While performing adjustments outlined in steps 1, 2, 3, 4, and 5, clutch control booster bell crank (3, figure 11) must be in full forward position.

1. Loosen clutch lever rod lock nut (12, figure 11) and adjust clutch lever rod (13, figure 11) far enough so clutch actuating lever on transmission has about 1/2 inch free movement. Move end of lever on transmission forward to a position where it becomes firm indicating that all slack in the actuating mechanism has been taken up. Measure clearance between chain housing and clutch lever which should be 1/4 inch. If necessary to readjust to obtain this position of lever follow the instructions in the next step.
2. This step is required only if clutch actuating lever is not positioned correctly (see figure 12). Remove chain housing cover, loosen push rod adjusting screw lock nut (2), and turn

push rod adjusting screw (3) in (clockwise) to move end of lever to the rear; out (counterclockwise) to move end of lever forward. When correct position of lever has been attained, tighten lock nut (2) and reinstall clutch cover.

3. Readjust clutch lever rod (1, figure 12) so end of clutch actuating lever has about 1/8 inch free movement. Loosen control coil adjusting sleeve lock nut (2, figure 11) and turn control coil adjusting sleeve (1, figure 11) all the way down. Loosen bell crank adjusting screw lock nut (9, figure 11) and adjust bell crank (3, figure 11) with bell crank adjusting screw (10, figure 11) so top end of bell crank moves 1/8 inch forward of dead center position as shown in figure 11. To determine dead center, move top end of bell crank by hand all the way to rear and then slowly move it forward. A point will be reached where bell crank will seem to hang. This is the dead center position. When top end of bell crank is moved forward beyond this point, booster spring exerts a forward pull on bell crank. This movement should be 1/8 inch over dead center. When adjustment has been made, tighten screw lock nut (9, figure 11).

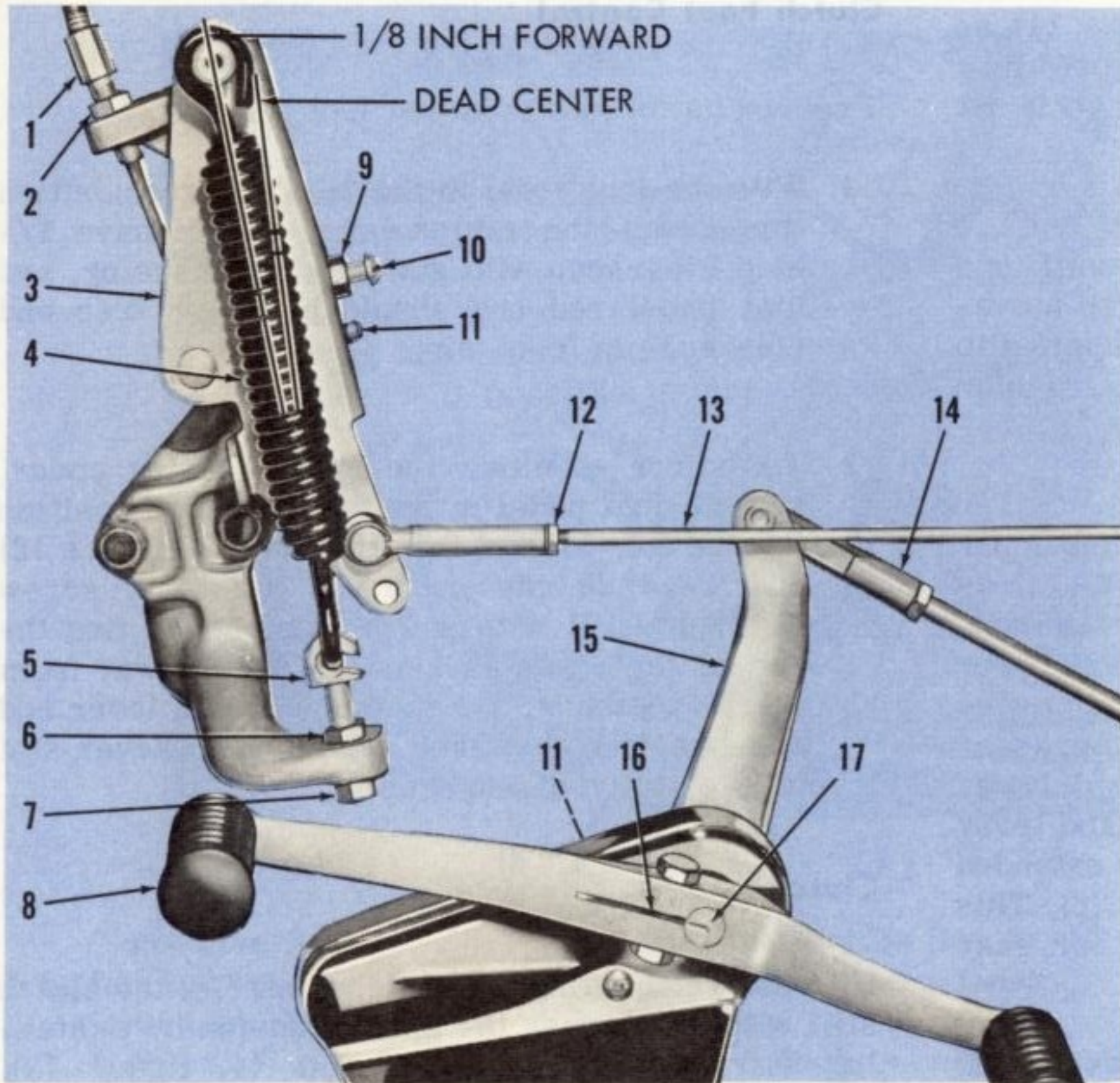

1. Control Coil Adjusting Sleeve
2. Control Coil Adjusting Sleeve Lock Nut
3. Clutch Control Booster Bell Crank
4. Clutch Control Booster Spring
5. Clutch Booster Spring Tension Adjuster
6. Clutch Booster Spring Tension Upper Adjuster Nut
7. Clutch Booster Spring Tension Lower Adjuster Nut
8. Gear Shifter Foot Lever and Rubber Pedal
9. Bell Crank Adjusting Screw Lock Nut
10. Bell Crank Adjusting Screw
11. Grease Gun Fittings (2)
12. Clutch Lever Rod Lock Nut
13. Clutch Lever Rod
14. Shifter Rod
15. Gear Shifter Lever
16. Foot Lever Clamping Slot
17. Foot Lever Positioning Mark

**FIGURE 11. HAND CLUTCH - FOOT SHIFT CONTROLS (SPRING COVER REMOVED)**

4. Readjust clutch lever rod (13, figure 11) so clutch actuating lever has  $1/16$  inch free movement. Tighten clutch lever rod lock nut (12, figure 11).
5. Turn adjusting sleeve (1) upward until end of clutch hand lever has  $1/2$  inch free movement before releasing pressure is applied to clutch. When adjustment is attained, tighten lock nut (2).
6. Loosen clutch booster spring tension upper adjusting nut (6) and turn nut upward as far as it will go. Compress clutch hand lever fully. Tighten clutch booster spring tension lower adjusting nut (7) until, with hand removed from hand lever, it remains in compressed position. Now slowly loosen (unscrew) lower adjusting nut (7) just enough so that hand lever comes back (hand off lever) to fully extended position. Tighten upper adjusting nut (6). This adjustment must be made carefully for easy operation of clutch hand lever.
7. Check to determine that foot lever positioning mark (17) is aligned with clamping slot (16) of foot lever (8).

## Clutch Foot Control

Proceed as follows to adjust foot control:

1. With the foot pedal in the fully engaged position (toe down) the clutch lever should have  $1/4$  inch clearance with starter drive housing, and foot pedal rod end should have  $1/8$  free end clearance in lever slot.
2. To adjust, remove the chain housing cover, set the foot pedal in the fully engaged position (toe down), loosen the lock nut (2, figure 12) and readjust the push rod adjusting screw (3, figure 12) with a screwdriver so that the end of the lever is about  $1/4$  inch away from starter housing. Be sure that clutch lever rod end has  $1/8$  inch free movement in lever slot before clutch disengages.

## Clutch

If, after readjusting the clutch controls, the clutch still slips, increase the spring tension by tightening (turn right) the three nuts (4, figure 12). Tighten all three nuts one-half turn at a time until clutch holds. Test after each half turn by

## WARNING

Whenever primary chain cover is removed, first disconnect battery cable from lower terminal of starter solenoid to prevent accidental starter operation and possible injury.

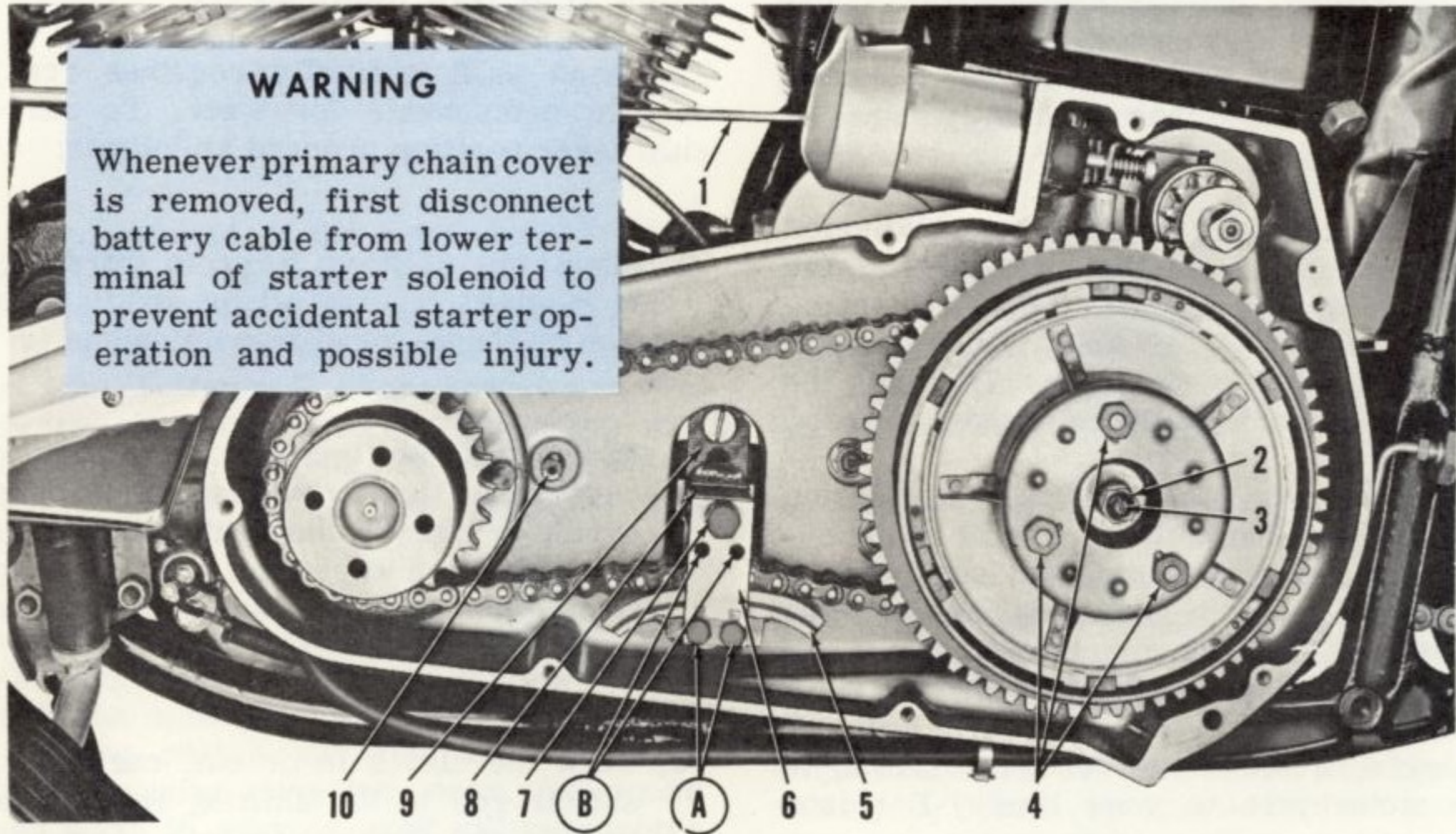

- |   |                                |   |
|---|--------------------------------|---|
| 1. Clutch Lever Rod                     | 4. Spring Tension Nuts (3)     | 8. Shoe Support Bracket                   |
| 2. Push Rod Adjusting<br>Screw Lock Nut | 5. Front Chain Adjusting Shoe  | 9. Slotted Backplate                      |
| 3. Push Rod Adjusting Screw             | 6. Outer Plate                 | 10. Front Chain Oiler                     |
|   | 7. Support Bracket Center Bolt | A and B. Two Sets of Shoe Attaching Holes |

**FIGURE 12. FRONT CHAIN AND CLUTCH ADJUSTMENT**

cranking the engine. Usually a clutch that holds without noticeable slippage when cranking the engine also holds on the road. Do not increase spring tension any more than is actually required to make clutch hold.

A new clutch is originally assembled and adjusted so that the distance from the inner edge of the shoulder on the spring collar to the outer surface of the outer disc is  $31/32$  inch. If compressed so that this distance is less than  $7/8$  inch, the clutch probably cannot be fully released.

If it is necessary to tighten the spring tension beyond the limit indicated above, it will be necessary to disassemble the clutch for inspection of the clutch discs. Some of the discs may be worn and require replacement or they may be oil soaked and in need of washing and drying.

It is advisable, if the above condition exists, to take your motorcycle to your Harley-Davidson dealer.

## Hand Shift (see figure 6)

The hand shift normally requires readjustment only to compensate for wear. To correct hand shift lever position proceed as follows:

1. Move the shifting lever to third position on four-speed transmissions and to second position on three-speed transmissions.
2. Disconnect shifter rod from shifter lever; with slight backward and forward movement carefully "feel" the transmission lever into exact position where the shifter spring plunger (inside transmission) seats fully in its retaining notch.
3. Turn the clevis in or out, carefully refit the shifter rod to the shifting lever without disturbing the shifting lever's exact positioning.

# CHASSIS

## Chains

Inspect the adjustment of the rear chain at 1000 mile intervals and the front chain at 2000 mile intervals and readjust them if necessary. Adjustment of front chain can be checked through inspection hole (1, figure 8) after removing cover. If chains are allowed to run too loose they will cause the motorcycle to jerk when running at low speed, and both the chains and sprockets will wear excessively.

Adjust both front and rear chains so they have about 1/2 inch free movement up and down, midway between sprockets. Do not adjust tighter, because running chains too tight is even more harmful than running them too loose. As chains stretch and wear in service, they will run tighter at one point on the sprockets than at another; always check adjustment at the tightest point.

Inspect chains occasionally for links in bad condition. If any are found, make repairs or renew the chain. The rear chain can be taken apart and

removed after locating and taking out the spring-locked connecting link. The front chain is not provided with such a connecting link. Therefore, it is necessary to remove the engine sprocket, chain adjuster and clutch before the chain can be taken off.

To disassemble chain housing cover, for access to chain, remove rear pivot bolt from left footboard and swing rear end of footboard down, away from chain housing cover. Remove 8 cover attaching screws and remove cover.

### Front Chain Adjustment (see figure 12)

Front chain tension is adjusted by means of a shoe (5) which is raised or lowered underneath the chain to tighten or loosen it. The shoe support bracket (8) moves up or down in slotted backplate (9) after loosening center bolt (7) in backplate nut. Adjust shoe support as necessary to obtain approximately 1/2 inch up and down free movement in upper strand of chain, midway between sprockets and retighten bolt securely.

Shoe support bracket (8) and outer plate (6) have two sets of shoe attaching holes (A and B) so that entire assembly can be inverted to accommodate various sprocket sizes or chain lengths.

To change over, remove center bolt (7), remove two shoe attaching capscrews from set of holes (A), invert shoe and attach to alternate set of holes (B) with capscrews. Invert support bracket and outer plate and reattach with center bolt engaged in backplate nut.

### Rear Chain Adjustment (see figure 15)

Remove the rear axle nut (3) and lock washer, and loosen brake sleeve nut (4) and brake anchor stud nut (5). Loosen the lock nut (6) on wheel adjusting screw (7) on both sides of motorcycle. Turn adjusting screws as necessary to correctly readjust the chain. Turn each screw an equal number of turns in order to keep wheel in alignment.

Check correct alignment of the wheel to see that the tire runs about midway between rear fork and also that the rear sprocket runs centrally in the chain. When readjustment is completed, be sure to securely retighten the sleeve nut, axle nut, anchor stud nut and adjusting screw lock nuts in order.

### Chain Repair (see figure 13)

When necessary to repair a chain, remove the damaged links by pushing out the riveted link

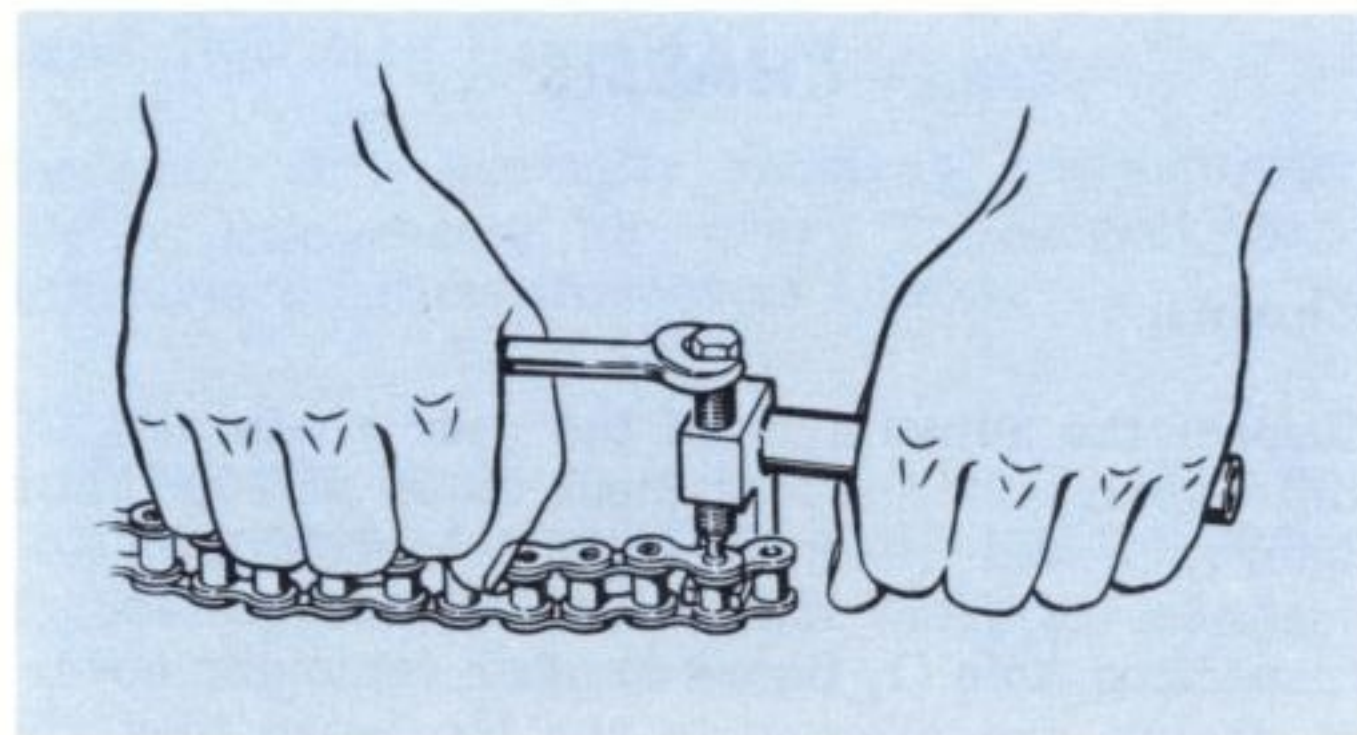

**FIGURE 13. REPAIRING DRIVE CHAIN**

pins with a chain repair tool as shown. Then fit the necessary repair links. A duplex chain is used for the front drive and a single width chain for the rear. The chain tool furnished in the accessory tool kit is designed to take care of both.

### Brakes

#### Front Brake Adjustment (see figure 14)

When the front wheel brake is properly adjusted the hand lever (1) will move freely about one-quarter of its full movement before the brake

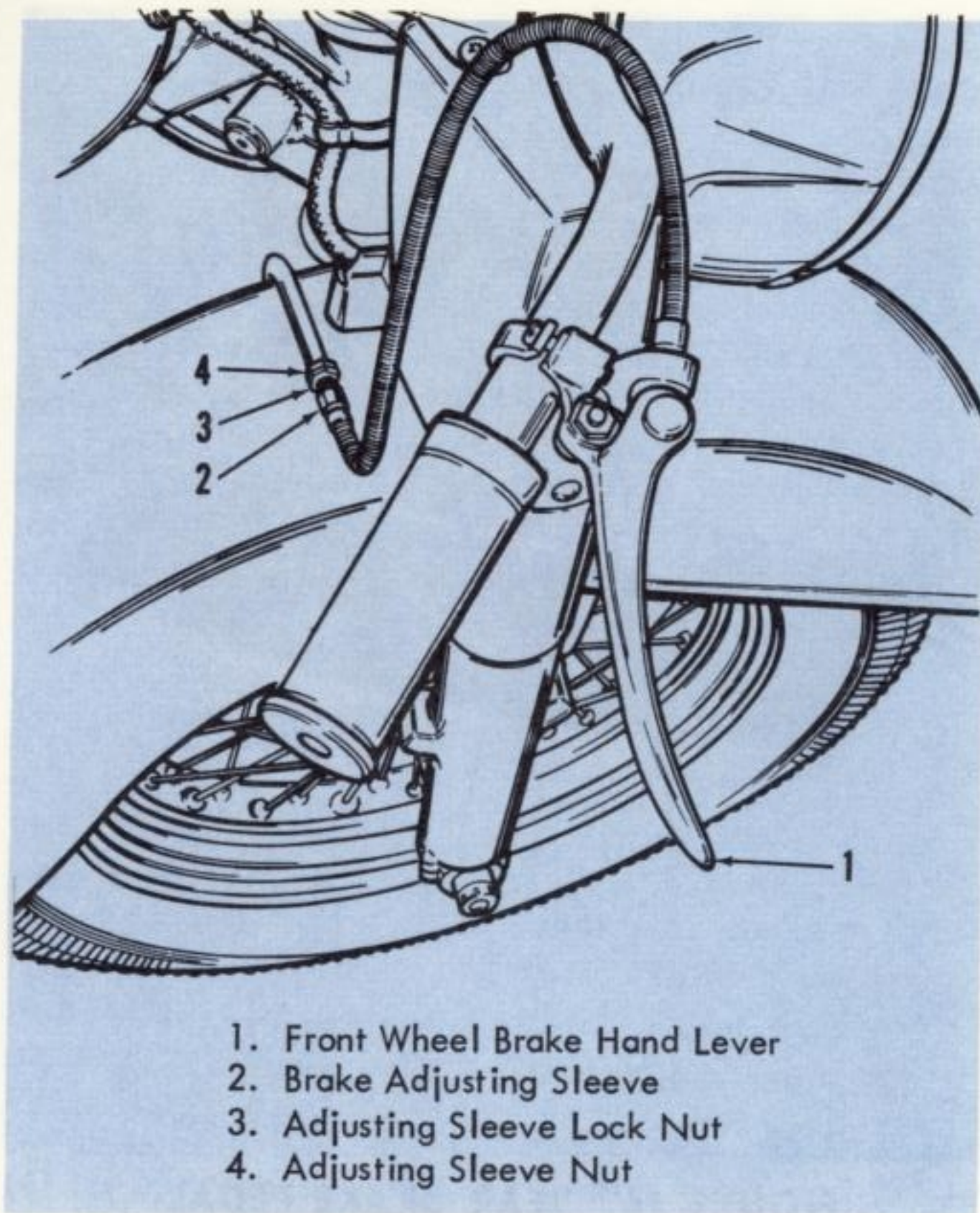

**FIGURE 14. FRONT BRAKE ADJUSTMENT**

starts to take effect. If adjusted tighter the brake may drag. To adjust brake, loosen lock nut (3) on adjusting sleeve (2) and turn lower nut (4) in toward the cable support tube to decrease the free movement of the lever (1) and tighten brake. Turn lower nut (4) away from the cable support tube to increase the free movement of lever and loosen brake. When free movement of the hand lever (1) is about one-quarter its full movement tighten lock nut (3) securely against the adjusting sleeve nut (4).

### Rear Brake Adjustment

The rear wheel is equipped with a hydraulic brake. When the brake is properly adjusted, the foot pedal will move freely approximately 1-1/4 inches before the brake starts to take effect. Adjustment of the brake shoes is required periodically to compensate for lining wear. Pedal adjustment may also be necessary due to pedal linkage wear.

### Brake Shoe Adjustment (see figure 15)

Remove chain guard rear mounting bolt and swing rear end of guard upward as shown in illustration.

To adjust brake shoes, raise rear wheel so it can be turned freely by hand. Two adjusting cam

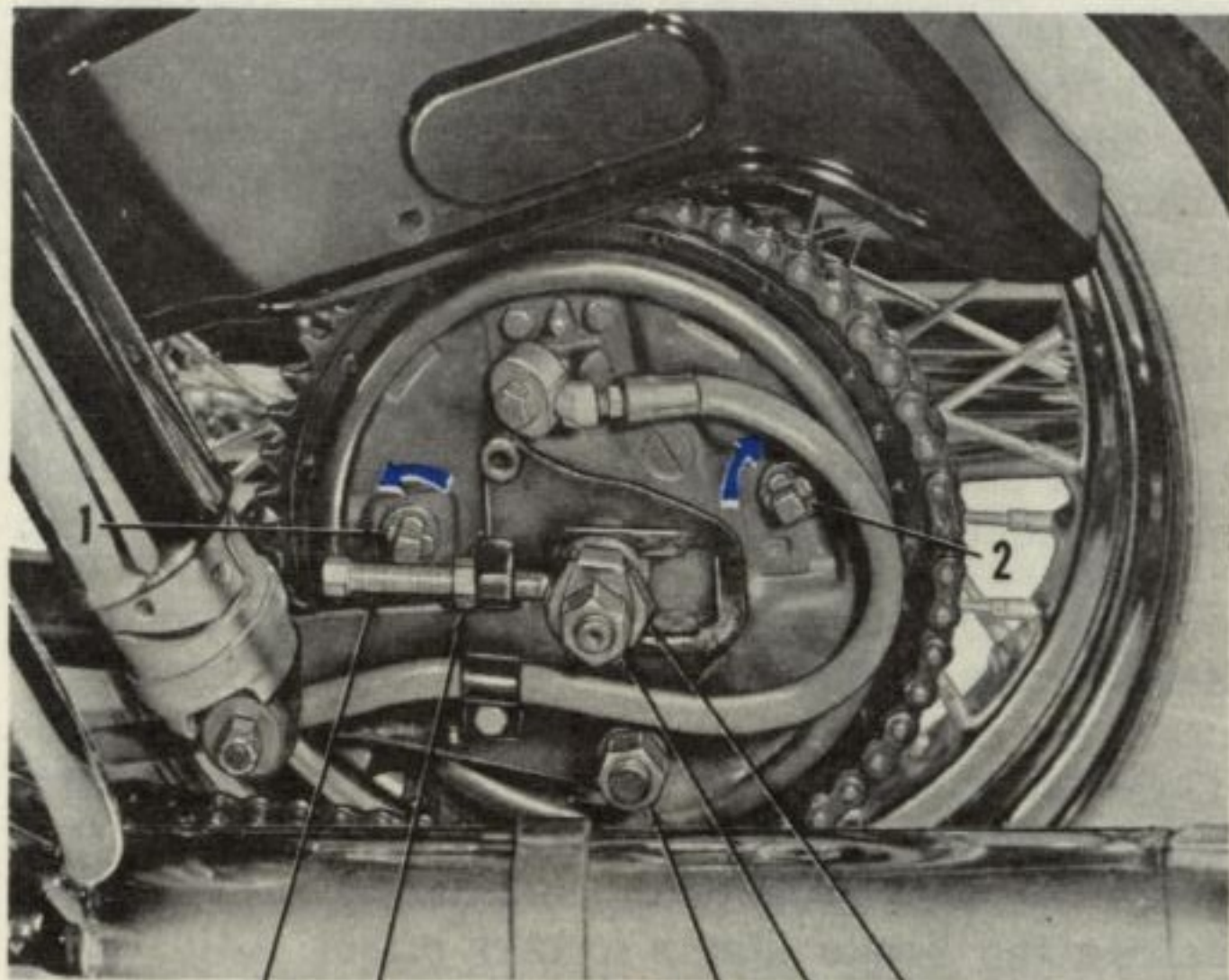

- |                                       |                                       |
|---------------------------------------|---------------------------------------|
| 1. Front Brake Shoe Adjusting Cam Nut | 5. Brake Anchor Stud Nut              |
| 2. Rear Brake Shoe Adjusting Cam Nut  | 6. Wheel Adjusting Screw Lock Nut (2) |
| 3. Rear Axle Nut                      | 7. Wheel Adjusting Screw (2)          |
| 4. Brake Sleeve Nut                   |                                       |

**FIGURE 15. REAR BRAKE SHOE AND CHAIN ADJUSTMENT**

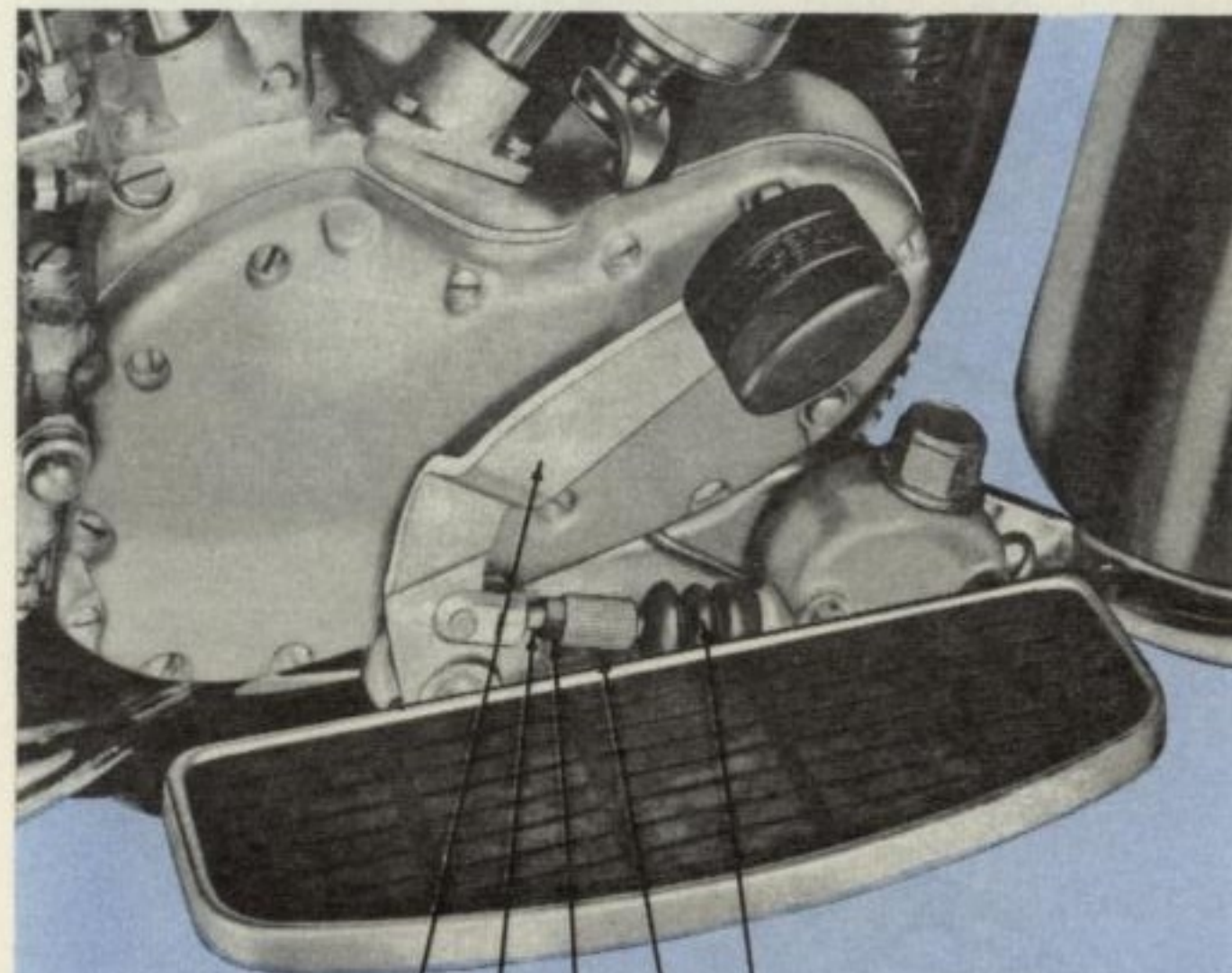

- |                    |                           |
|--------------------|---------------------------|
| 1. Brake Pedal     | 4. Push Rod Adjusting Nut |
| 2. Piston Push Rod | 5. Rubber Boot            |
| 3. Lock Nut        |                           |

**FIGURE 16. REAR BRAKE PEDAL ADJUSTMENT**

square head nuts (1) and (2), one for each brake shoe, are located on the outside of the brake backing plate. Using a square end wrench on front cam shoe nut, turn brake front shoe cam (1) counterclockwise until lining contacts drum, causing a noticeable drag when wheel is turned. Rock wheel back and forth to center the brake shoes. Next, back off cam approximately 1/32 turn, until wheel turns freely. Repeat this adjusting procedure on rear shoe cam nut (2), turning the rear shoe cam clockwise until lining contacts drum and brake drags; rock wheel, and back off cam 1/32 turn until wheel turns freely.

### Brake Pedal Adjustment (see figure 16)

Pull rubber boot (5) away from end of master cylinder housing to expose piston push rod link. Holding push rod link in center of opening, work brake pedal (1) back and forth by hand to determine free play before push rod contacts piston in master cylinder. Free play of push rod should be approximately 1/16 inch. Adjustment is made by loosening lock nut (3) and turning knurled nut (4) to shorten or lengthen piston push rod (2) as needed. Retighten lock nut (3) securely after desired free play is obtained.

## Wheels

Front and rear wheels can be detached when necessary to remove for wheel or tire service. When detached from drums, wheels are interchangeable.

### Removing Rear Wheel (see figure 17)

Support rear end of motorcycle with rear wheel off the ground. Remove two rear screws from fender support, and raise end of fender. Remove the five socket screws that secure wheel to brake drum. The socket screw wrench can be inserted only at the rear of axle so the wheel will have to be turned to bring each screw to this position.

Remove axle nut (3) and axle nut lock (2). Remove axle (1) and then remove spacer (5) from between wheel hub and right axle clip. Apply rear brake to hold brake drum securely while pulling wheel away from brake drum. Wheel is then free to come out to rear with fender end raised as shown.

#### NOTE

Foot Brake Lever Locking Tool, Part No. 95875-58, can be used to lock brake. To use tool, raise right side foot board, slip tool over brake lever stop pin, depress



## Wheel Hubs

Excessive side play or radial (up and down) play in the wheel hubs can be removed by the addition of thrust bearing shims (side play) or the replacement of roller bearings with oversize roller bearings (radial play).

It is advisable to have any needed wheelhub repair made at your Harley-Davidson dealer where roller bearings in assorted sizes and any other parts required are at hand. Refitting should be done by a mechanic thoroughly familiar with this service operation because care must be exercised to avoid fits that are too tight.

## Tires

Care should be taken to keep tires properly inflated. See Tire Data, Page 3, for correct tire inflation pressures. Do not over-inflate tires. The front tire of a solo motorcycle normally wears unevenly and becomes peaked to some extent. It is recommended, with a solo motorcycle particularly, that wheels and tires be transposed at intervals of approximately 5,000 miles. This will stabilize high speed operation and also equalize wear.

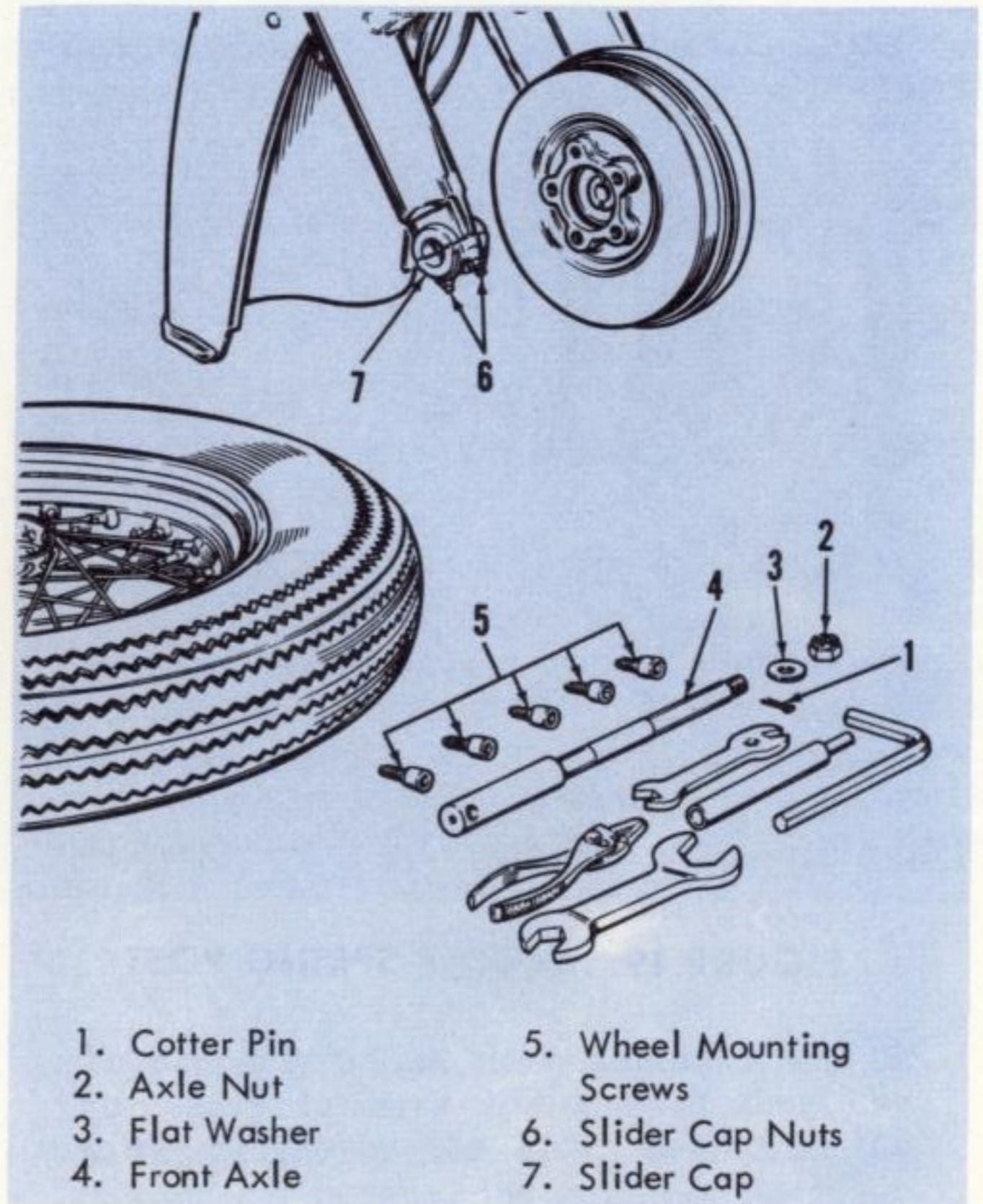
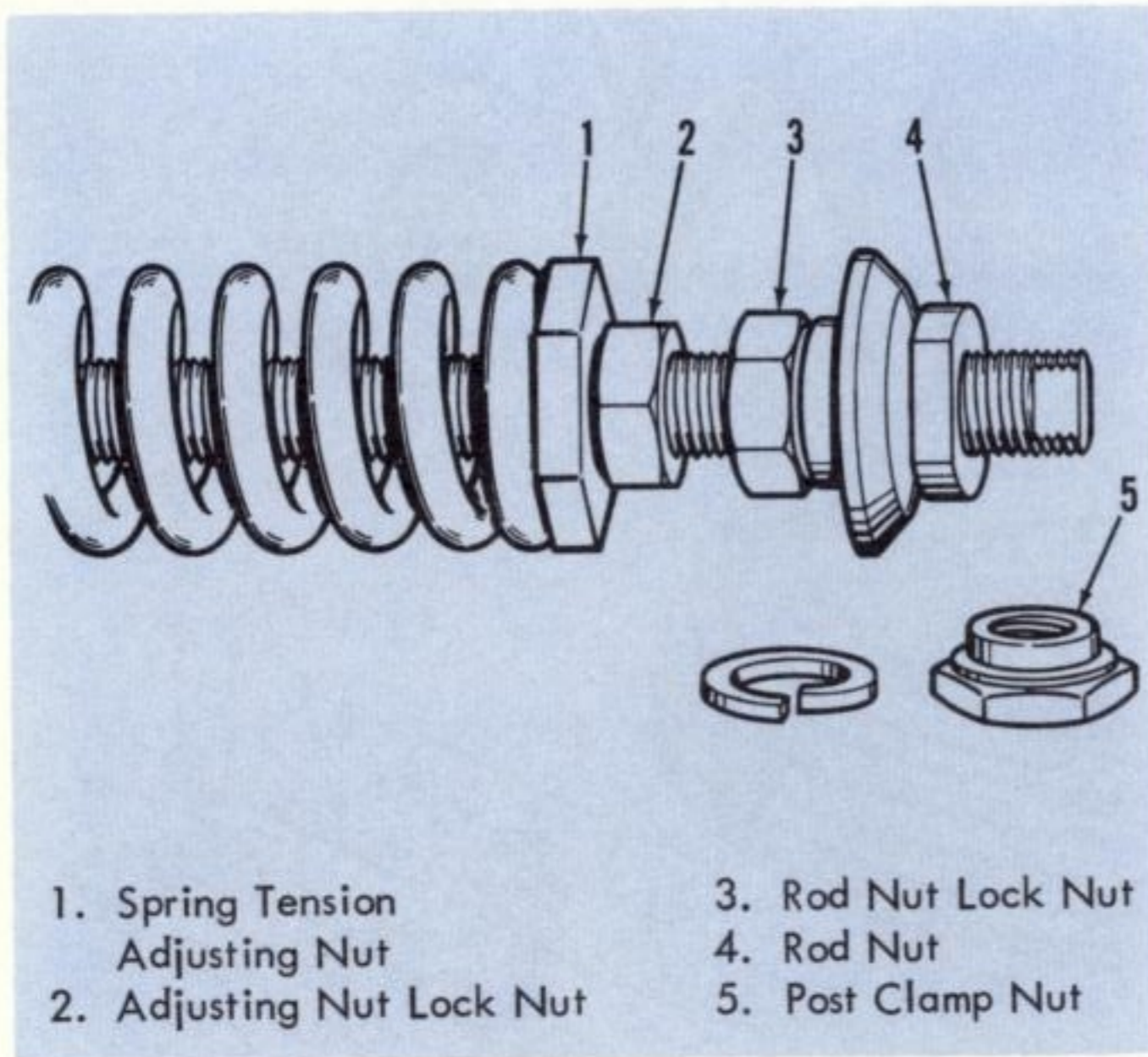

FIGURE 18. FRONT WHEEL REMOVAL

## Saddle Spring Post (see figure 19)



**FIGURE 19. SADDLE SPRING POST**

After raising the saddle, remove saddle post clamp nut (5), which is located underneath frame at bottom end of post tube. The post assembly can then be pulled out. When the post assembly is inserted back into the frame tube see that the flat side, machined on the post rod nut (4), registers in flat side of the hole in the bottom of the tube.

The cushion spring assembly (three lower springs) of a standard saddle post is adjusted for the average weight rider to give maximum riding comfort. Adjustment can be changed for lighter or heavier than average rider, and different springs can be obtained, if desired, from your dealer.

# ELECTRICAL

## Headlamp

The headlamp is of the sealed beam type. When replacement is required use only the prescribed sealed unit available from your Harley-Davidson dealer.

Replacing Headlamp Sealed Beam Unit (see figure 20)

If either filament burns out or if the lens breaks, the entire sealed beam unit must be discarded and a new unit installed.

To install a new unit loosen door screw (1) enough to remove headlamp door (2). Remove the three retaining ring screws (5). Unhook spring from hole (3) in retaining ring (4) and remove retaining ring. The sealed beam unit (6) is now free from the headlamp body, and the connector block (7) can now be removed from the unit by pulling connector block from the unit's prongs.

Install the new unit by reversing above operations. Make sure prongs on unit are clean to assure good contact with connector block.

No attempt should be made to repair a defective sealed beam unit. When the seal is broken the reflector tarnishes and poor light and road visibility result.

## Headlamp Adjustment (see figure 20)

The headlamp beam must be adjusted for height and direction. To get the greatest efficiency from the headlamp and to meet the requirements of the law make the following adjustment in a darkened room or at night.

1. Have the motorcycle standing on a level surface with tires correctly inflated about 25 feet away from, and headed toward, a wall or screen upon which a horizontal line has been drawn at exactly the same height as the headlamp center. The motorcycle must be resting on both wheels and the front wheel must be in straight alignment.

### NOTE

To properly adjust the headlamp it will be necessary to have someone of about the same weight as the rider seated on the motorcycle because the weight of the rider will compress the fork slightly.

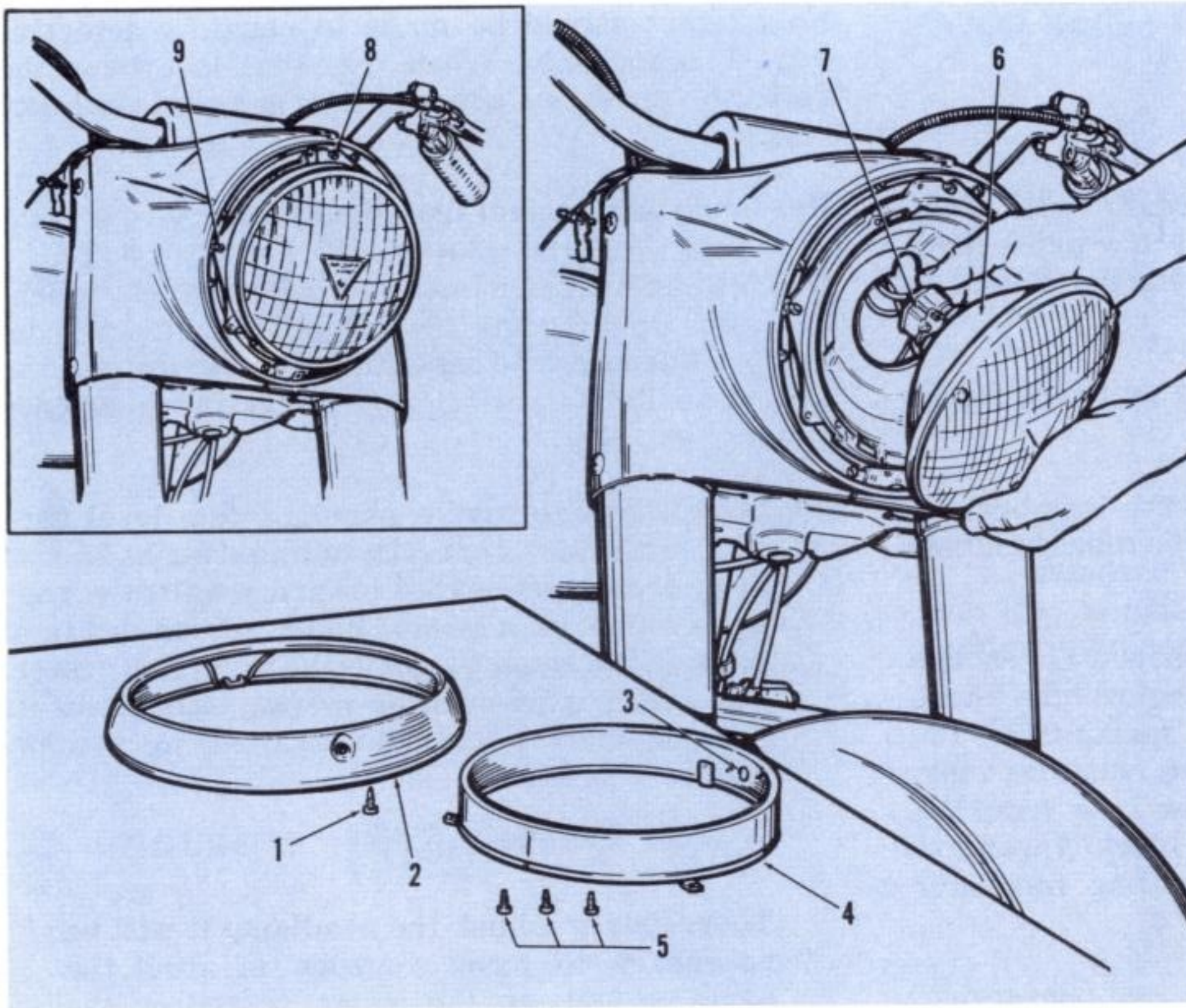

1. Door Screw
2. Headlamp Door
3. Spring Hole
4. Retaining Ring
5. Retaining Ring  
Screws
6. Sealed Beam Unit
7. Connector Block
8. Vertical Adjustment  
Screw
9. Horizontal Adjustment  
Screw

**FIGURE 20. REPLACING THE SEALED-BEAM UNIT**

2. Turn on light switch, set handlebar toggle switch in BRIGHT position, and check light beam for height and direction. The top of the main beam of light should register on the wall or screen even with, but no higher than, the horizontal line mentioned above.
3. If beam requires adjustment, remove headlamp door. The lamp can be tilted up or down to aim it in relation to the horizontal line by turning vertical adjustment screw (8) in or out. The lamp can be aimed to the right or left in relation to the front wheel by turning the horizontal adjustment screw (9) in or out.

### **Generator Charging Rate and Regulator**

The generator itself has no adjustment for control of charging rate. This is controlled by the regulator. The regulator functions to increase charging rate when battery is low or lamps are lighted, and to decrease charging rate when no lamps are lighted and when battery is up. The regulator requires no interval attention. The cutout relay is combined with the regulator in a single unit. Should any

electrical system trouble be experienced that might be traceable to the regulator, motorcycle should be taken to your Harley-Davidson dealer who has the necessary electrical testing equipment to give required attention.

### **Inspecting or Replacing Generator Brushes**

To inspect generator commutator and brushes, remove inspection cover band. Commutator should appear smooth and clean. Replace brushes when longest side of brush measures 1/2 inch or less. Excessive brush wear will be indicated if brush lead wire enters brush holder slot close to commutator. Generator should be removed from engine and disassembled to replace brushes or recondition commutator. It is recommended that generator maintenance be performed by your Harley-Davidson dealer.

### **Bulb Chart**

The bulb chart, page 56, gives the location and bulb requirements for your Harley-Davidson motorcycle.

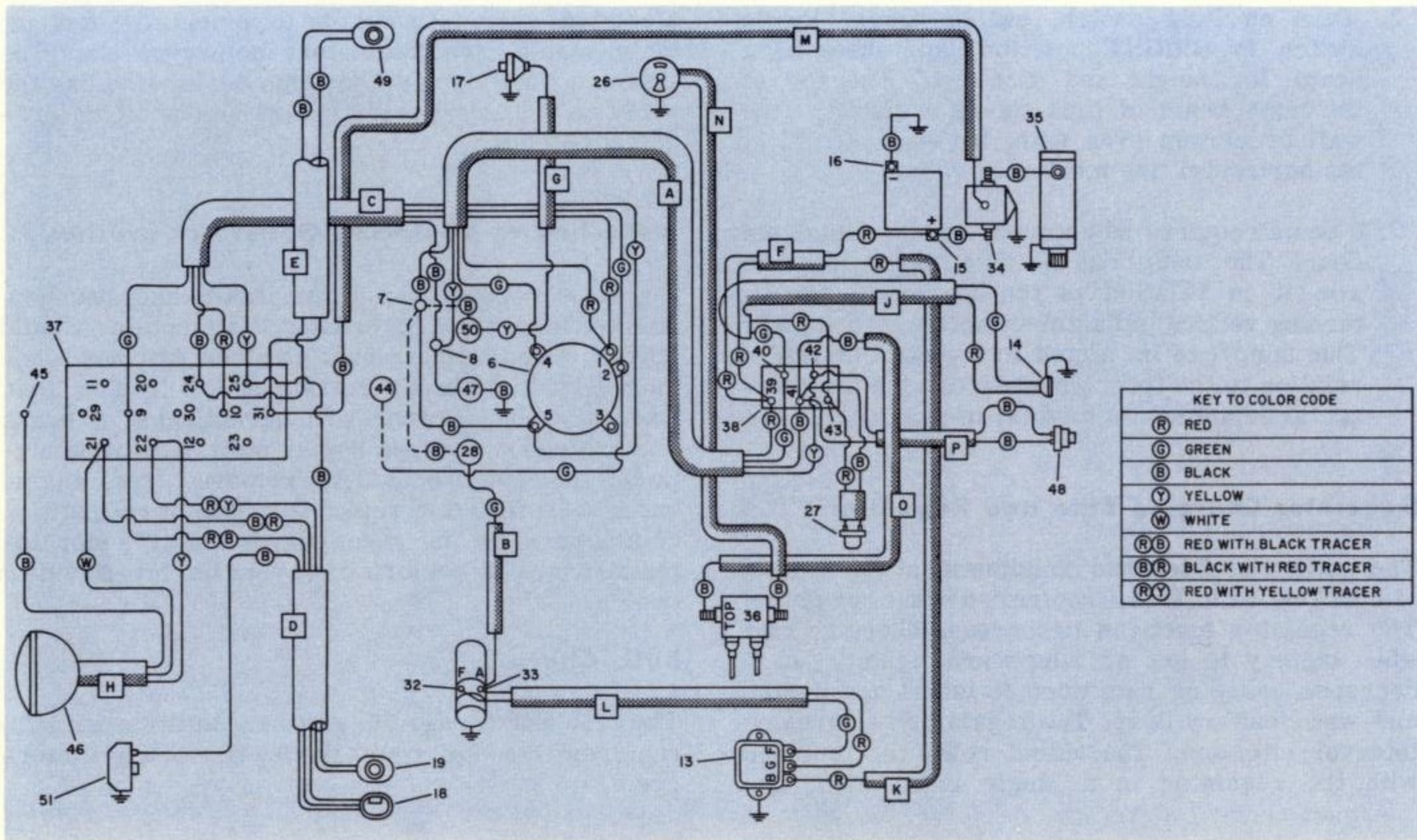

KEY TO COLOR CODE	
(R)	RED
(G)	GREEN
(B)	BLACK
(Y)	YELLOW
(W)	WHITE
(R/B)	RED WITH BLACK TRACER
(B/R)	BLACK WITH RED TRACER
(R/Y)	RED WITH YELLOW TRACER

FIGURE 21. WIRING DIAGRAM

## KEY FOR WIRING DIAGRAM

- A. Conduit (four wire) - Red, green, black and yellow
- B. Conduit (one wire) - Green
- C. Conduit (four wire) - Red, green, yellow and black
- D. Left handlebar (loose wires) - Red with black tracer, black with red tracer, red with yellow tracer, 2 black wires
- E. Right handlebar (loose wires) - 2 black wires
- F. Conduit (two wire) - 2 red wires
- G. Conduit (one wire) - Yellow
- H. Conduit (three wire) - Black, white and yellow
- J. Conduit (two wire) - Red and green
- K. Conduit (one wire) - Red
- L. Conduit (two wire) - Green and red
- M. Conduit (one wire) - Black
- N. Conduit (one wire) - Black
- O. Conduit (one wire) - Black
- P. Conduit (two wires) - 2 black wires
- 1. Switch terminal - Switch supply
- 2. Switch terminal - Headlamp
- 3. Switch terminal - Not used with standard wiring
- 4. Switch terminal - Tail lamp
- 5. Switch terminal - Ignition coil
- 6. Ignition - Light switch - See terminals 1 through 5
- 7. Junction terminal
- 8. Junction terminal
- 9. Terminal
- 10. Terminal
- 11. Terminal - Not used with standard wiring
- 12. Terminal - Not used with standard wiring
- 13. Regulator
- 14. Tail and stop lamp
- 15. Battery positive terminal
- 16. Battery negative terminal
- 17. Oil pressure signal switch
- 18. Handlebar headlamp switch
- 19. Horn switch
- 20. Terminal - Not used with standard wiring
- 21. Terminal
- 22. Terminal
- 23. Terminal - Not used with standard wiring
- 24. Terminal
- 25. Terminal
- 26. Ignition circuit breaker
- 27. Stop lamp switch
- 28. Generator signal light
- 29. Terminal - Not used with standard wiring
- 30. Terminal - Not used with standard wiring
- 31. Terminal
- 32. Generator "F" terminal
- 33. Generator "A" terminal
- 34. Starter solenoid
- 35. Starter motor
- 36. Ignition Coil
- 37. Terminal plate
- 38. Terminal box - See terminals 39 through 43
- 39. Terminal
- 40. Terminal
- 41. Terminal
- 42. Terminal
- 43. Terminal
- 44. Speedometer light
- 45. Terminal plate top mounting screw (ground)
- 46. Headlamp
- 47. Neutral indicator light
- 48. Neutral switch
- 49. Starter button
- 50. Oil signal light
- 51. Horn

## BULB CHART

Lamp Description	Number of Bulbs Required	Candle Power or Wattage	Harley-Davidson Part Number
<p style="text-align: center;"><b>HEADLAMP</b></p> <p>Hi Beam Low Beam</p>	1	50 Watts 45 Watts	67717-64
<p style="text-align: center;"><b>TAIL AND STOP LAMP</b></p> <p>Tail Lamp Stop Lamp</p>	1	4C.P. 32C.P.	68165-64
<p style="text-align: center;"><b>INSTRUMENT PANEL</b></p> <p>Neutral Indicator Light Generator Signal Light Oil Pressure Signal Light Speedometer Light</p>	1 1 1 1	2C.P. 2C.P. 2C.P. 1.5C.P.	68462-64 68462-64 68462-64 71090-64
<p style="text-align: center;"><b>ACCESSORIES</b></p> <p>Spot Lamp Sealed Beam Unit Spot Lamp Bulb Parking Lamps Turn Indicator Lamps Turn Indicator Pilot Lamps</p>	1 1 - 4 2	30 Watts 32C.P. 3C.P. 32C.P. 1.5C.P.	68726-64 68715-64 68166-64 68572-64A 71090-64

# INDEX

	Page		Page
Air Cleaner . . . . .	24	Maintenance . . . . .	31
Battery . . . . .	29	New Motorcycle Service . . . . .	20
Brake Adjustment . . . . .	44	Oil Filter . . . . .	24
Bulb Chart . . . . .	56	Operating Tips. . . . .	16
Carburetor . . . . .	32	Regular Service Intervals . . . . .	21
Chain Adjustment . . . . .	25	Riding . . . . .	13
Chain Lubrication . . . . .	25	Rules of the Road . . . . .	19
Circuit Breaker and Ignition Timing . . . . .	33	Saddle Spring Post . . . . .	50
Cleaning. . . . .	30	Servicing. . . . .	20
Clutch. . . . .	40	Service Chart . . . . .	22
Controls. . . . .	7	Spark Plugs . . . . .	31
Electrical. . . . .	51	Specifications . . . . .	2
Engine Lubrication . . . . .	23	Starting and Stopping Instructions. . . . .	13
First 500 Miles (Break-in Period) . . . . .	13	Tappets . . . . .	37
Gasoline Strainer . . . . .	25	Tires. . . . .	49
Generator . . . . .	53	Transmission Adjustment . . . . .	37
Greasing and Oil Applications . . . . .	27	Transmission Lubrication . . . . .	25
Headlamp . . . . .	51	Wheels . . . . .	47
Hydraulic Brake . . . . .	29	Winter Lubrication . . . . .	24
Locating Operating Troubles . . . . .	16	Wiring Diagram . . . . .	54



**HARLEY-DAVIDSON MOTOR CO.**  
MILWAUKEE, WISCONSIN 53201