

 **HONDA**

OWNER'S MANUAL



CBR125RW

This manual should be considered a permanent part of the motorcycle and should remain with the motorcycle when it is resold.

This publication includes the latest production information available before printing. Honda Motor Co., Ltd. reserves the right to make changes at any time without notice and without incurring any obligation.

No part of this publication may be reproduced without written permission.

© 2007 Honda Motor Co., Ltd.

2007
Honda CBR125RW
OWNER'S MANUAL

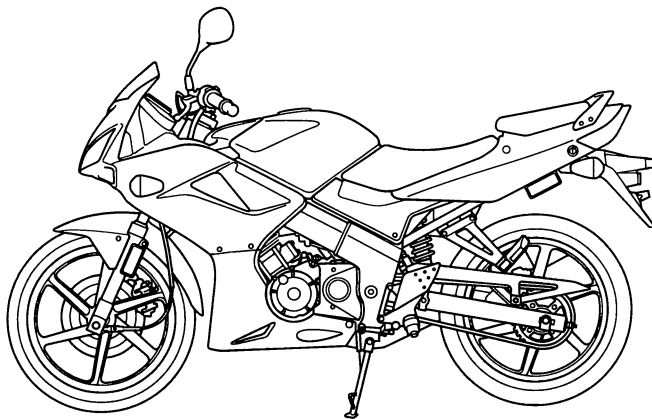

Introduction

Congratulations on choosing your Honda motorcycle.

When you own a Honda, you're part of a worldwide family of satisfied customers — people who appreciate Honda's reputation for building quality into every product.

Before riding, take time to get acquainted with your motorcycle and how it works. To protect your investment, we urge you to take responsibility for keeping your motorcycle well maintained. Scheduled service is a must, of course. But it's just as important to observe the break-in guidelines, and perform all pre-ride and other periodic checks detailed in this manual.

Introduction

We also recommend that you read this owner's manual before you ride. It's full of facts, instructions, safety information, and helpful tips. To make it easy to use, the manual contains a detailed list of topics at the beginning of each section, and both an in-depth table of contents and an index at the back of the book.

As you read this manual, you will find information that is preceded by a **NOTICE** symbol. This information is intended to help you avoid damage to your Honda, other property, or the environment.

Read the Warranties Booklet (page 187) thoroughly so you understand the coverages that protect your new Honda and are aware of your rights and responsibilities.

If you have any questions, or if you ever need special service or repairs, remember that your Honda dealer knows your motorcycle best and is dedicated to your complete satisfaction.

Please report any change of address or ownership to your Honda dealer so we will be able to contact you concerning important production information.

You may also want to visit our website at www.honda.ca.

Happy riding!

A Few Words About Safety

Your safety, and the safety of others, is very important. And operating this motorcycle safely is an important responsibility.

To help you make informed decisions about safety, we have provided operating procedures and other information on labels and in this manual. This information alerts you to potential hazards that could hurt you or others.

Of course, it is not practical or possible to warn you about all hazards associated with operating or maintaining a motorcycle. You must use your own good judgment.

You will find important safety information in a variety of forms, including:

- **Safety Labels** — on the motorcycle.
- **Safety Messages** — preceded by a safety alert symbol  and one of three signal words: **DANGER, WARNING, or CAUTION.**

These signal words mean:

Safety Messages

A Few Words About Safety

DANGER

You **WILL** be **KILLED** or **SERIOUSLY HURT** if you don't follow instructions.

WARNING

You **CAN** be **KILLED** or **SERIOUSLY HURT** if you don't follow instructions.

CAUTION

You **CAN** be **HURT** if you don't follow instructions.

- **Safety Headings** — such as Important Safety Reminders or Important Safety Precautions.
- **Safety Section** — such as Motorcycle Safety.
- **Instructions** — how to use this motorcycle correctly and safely.

This entire manual is filled with important safety information — please read it carefully.

Contents

These pages give an overview of the contents of your owner's manual. The first page of each section lists the topics covered in that section.

Motorcycle Safety..... 1

Important safety information you should know, plus a look at the safety-related labels on your motorcycle.

Instruments & Controls..... 9

The location and function of indicators, gauges, and controls on your motorcycle and operating instructions for various controls and features.

Before Riding..... 21

The importance of wearing a helmet and other protective gear, how to make sure you and your motorcycle are ready to ride, and important information about loading.

Basic Operation & Riding..... 31

How to start and stop the engine, shift gears, and brake. Also, riding precautions and important information about riding with a passenger or cargo.

Servicing Your Honda 47

Why your motorcycle needs regular maintenance, what you need to know before servicing your Honda, an owner maintenance schedule, and instructions for specific maintenance and adjustment items.

Tips..... 129

How to store and transport your motorcycle and how to be an environmentally-responsible rider.

Taking Care of the Unexpected 137

What to do if you have a flat tire, your engine won't start, etc.

Technical Information 163

ID numbers, technical specifications, and other technical facts.

Consumer Information 185

Information on warranties, emission controls.

Table of Contents 192

Sequential listing of topics in this owner's manual.

Index..... 196

Quick Reference

Handy facts about fuel, engine oil, tire sizes, and air pressures.

Motorcycle Safety

This section presents some of the most important information and recommendations to help you ride your motorcycle safely. Please take a few moments to read these pages. This section also includes information about the location of safety labels on your motorcycle.

Important Safety Information	2
Accessories & Modifications	5
Safety Labels	7

Important Safety Information

Your motorcycle can provide many years of service and pleasure — if you take responsibility for your own safety and understand the challenges you can meet while riding.

There is much that you can do to protect yourself when you ride. You'll find many helpful recommendations throughout this manual. The following are a few that we consider most important.

Always Wear a Helmet

It's a proven fact: helmets significantly reduce the number and severity of head injuries. So always wear an approved motorcycle helmet and make sure your passenger does the same. We also recommend that you wear eye protection, sturdy boots, gloves, and other protective gear (page 22).

Important Safety Information

Take Time to Learn & Practice

Even if you have ridden other motorcycles, take time to become familiar with how this motorcycle works and handles.

Practice in a safe area until you build your skills and get accustomed to the motorcycle's size and weight.

Because many accidents involve inexperienced or untrained riders, we urge all riders to take a certified course at your local motorcycle rider training school.

Ride Defensively

The most frequent motorcycle collision happens when a car turns left in front of a motorcycle. Another common situation is a car moving suddenly into your lane.

Always pay attention to other vehicles around you, and do not assume that other drivers see you. Be prepared to stop quickly or make an evasive maneuver.

Make Yourself Easy to See

Some drivers do not see motorcycles because they are not looking for them. To make yourself more visible, wear bright reflective clothing, position yourself so other drivers can see you, signal before turning or changing lanes, and use your horn when it will help others notice you.

Important Safety Information

Ride within Your Limits

Pushing limits is another major cause of motorcycle accidents. Never ride beyond your personal abilities or faster than conditions warrant. Remember that alcohol, drugs, fatigue, and inattention can significantly reduce your ability to make good judgments and ride safely.

Don't Drink and Ride

Alcohol and riding don't mix. Even one drink can reduce your ability to respond to changing conditions, and your reaction time gets worse with every additional drink. So don't drink and ride, and don't let your friends drink and ride either.

Keep Your Honda in Safe Condition

It's important to keep your motorcycle properly maintained and in safe riding condition. To help avoid problems, inspect your motorcycle before every ride and perform all recommended maintenance. Never exceed load limits (page 29), and do not modify your motorcycle (page 6) or install accessories that would make your motorcycle unsafe (page 5).

Modifying your motorcycle or using non-Honda accessories can make your motorcycle unsafe. Before you consider making any modifications or adding an accessory, be sure to read the following information.

⚠ WARNING

Improper accessories or modifications can cause a crash in which you can be seriously hurt or killed.

Follow all instructions in this owner's manual regarding accessories and modifications.

Accessories

We strongly recommend that you use only genuine Honda accessories that have been specifically designed and tested for your motorcycle. Because Honda cannot test all other accessories, you must be personally responsible for proper selection, installation, and use of non-Honda accessories.

Check with your Honda dealer for assistance and always follow these guidelines:

- Make sure the accessory does not obscure any lights, reduce ground clearance and lean angle, limit suspension travel or steering travel, alter your riding position, or interfere with operating any controls. (cont'd)

Accessories & Modifications

- Do not add any electrical equipment that will exceed the motorcycle's electrical system capacity (page 172). A blown fuse can cause a loss of lights or engine power (page 156).
- Do not pull a trailer or sidecar with your motorcycle. This motorcycle was not designed for these attachments, and their use can seriously impair your motorcycle's handling.

Modifications

We strongly advise you not to remove any original equipment or modify your motorcycle in any way that would change its design or operation. Such changes could seriously impair your motorcycle's handling, stability, and braking, making it unsafe to ride.

Removing or modifying your lights, exhaust system, emission control system, or other equipment can also make your motorcycle illegal.

Safety Labels

Safety labels on your motorcycle either warn you of potential hazards that could cause serious injury or they provide important safety information. Read these labels carefully and don't remove them.

If a label comes off or becomes hard to read, contact your Honda dealer for a replacement.

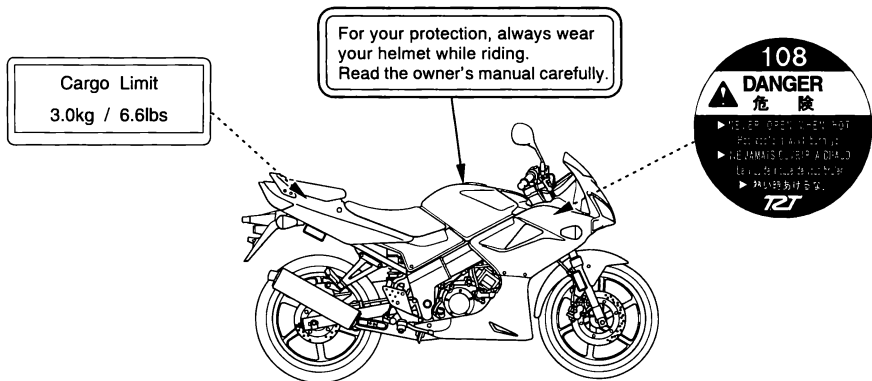

Safety Labels

▲ WARNING

Improper loading can cause a crash and you may be seriously hurt or killed. See "Load Limits and Guidelines" in your Owner's Manual for complete instructions.

TIRE INFORMATION		
Cold tire pressures: (Up to maximum weight capacity)	Front	Rear
Front 200kPa 2.00kg/cm ² 29psi	IRC	NR73s NR73s
Rear 225kPa 2.25kg/cm ² 33psi		
(Up to 90kg(200lbs) load)		
Front 200kPa 2.00kg/cm ² 29psi		
Rear 225kPa 2.25kg/cm ² 33psi		
Tire size : Front 80/80-17MC 44P		
Rear 100/80-17MC 52P		

Read owner's manual.

This motorcycle is equipped with tubeless tires.

Maximum weight capacity : 170kg(375lbs)

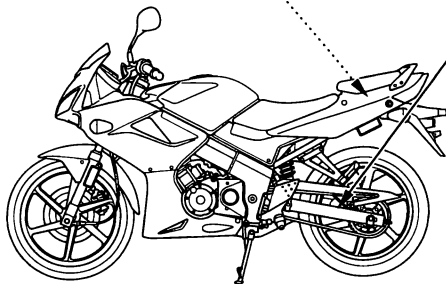

Instruments & Controls

This section shows the location of all gauges, indicators, and controls you would normally use before or while riding your motorcycle.

The items listed on this page are described in this section. Instructions for other components are presented in other sections of this manual where they will be most useful.

Operation Component Locations	10
Gauges & Indicators	13
Controls & Features.....	17
Ignition Switch	17
Start Button.....	18
Engine Stop Switch	18
Headlight Dimmer Switch	19
Turn Signal Switch.....	19
Horn Button	20

Operation Component Locations

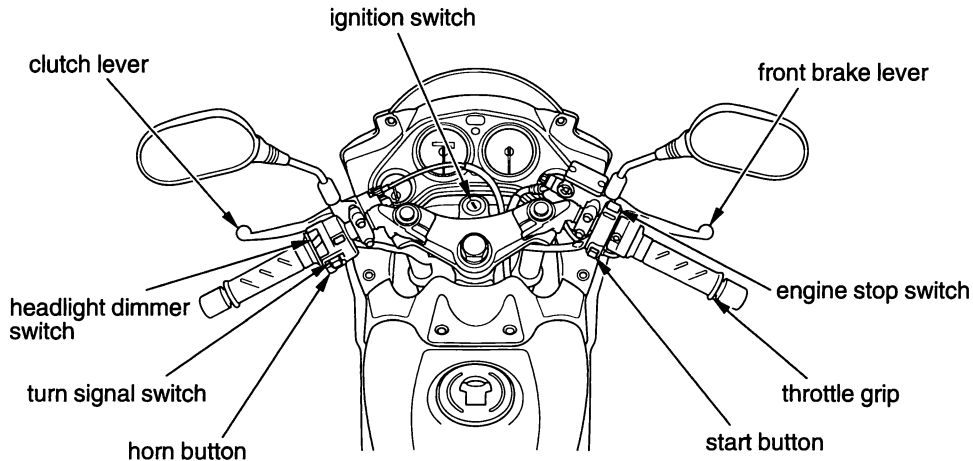

Operation Component Locations

helmet holder

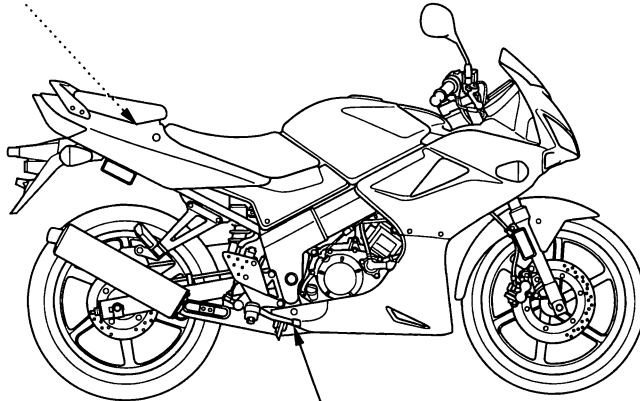

rear brake pedal

Operation Component Locations

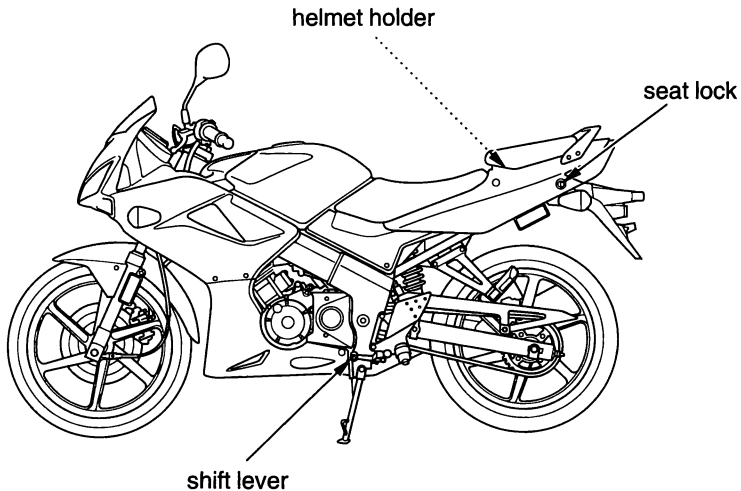

Gauges & Indicators

The gauges and indicators on your motorcycle keep you informed, alert you to possible problems, and make your riding safer and more enjoyable. Refer to the gauges and indicators frequently. Their functions are described on the following pages.

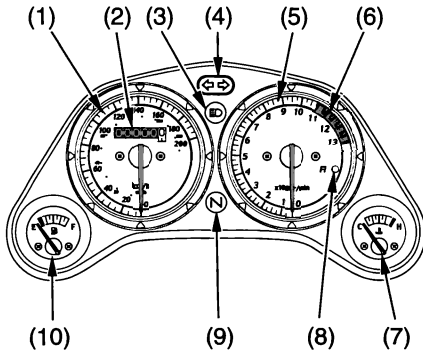

- (1) speedometer
- (2) odometer
- (3) high beam indicator
- (4) turn signal indicator
- (5) tachometer
- (6) tachometer red zone
- (7) coolant temperature gauge
- (8) PGM-FI malfunction indicator lamp (MIL)
- (9) neutral indicator
- (10) fuel gauge

Gauges & Indicators

Lamp Check

The PGM-FI malfunction indicator lamp lights for a few seconds and then goes off when you turn the ignition switch ON so you can check that it is working. This indicator is identified in the table on page 16 with the words: *Lamp check*.

When applicable, the high beam and neutral indicators come on when you turn the ignition switch ON and remain on until you select the low beam or shift out of neutral.

If one of these indicators does not come on when it should, have your Honda dealer check for problems.

Gauges & Indicators

1	speedometer	Shows riding speed in kilometers per hour.
2	odometer	Shows the total kilometers ridden.
3	high beam indicator (blue)	Lights when the headlight is on high beam.
4	turn signal indicator (amber)	Flashes when either turn signal operates.
5	tachometer	Shows engine speed in revolutions per minute (rpm).
6	tachometer red zone	Shows excessive engine rpm range (indicated from the beginning of the tachometer red zone) in which operation may damage the engine. Do not let the tachometer needle enter the red zone.

Gauges & Indicators

7	coolant temperature gauge	Shows engine coolant temperature. When the needle moves above the C (cold) mark, the engine is warm enough to start riding. If the needle approaches the H (hot) mark, pull safely to the side of the road. See page 154 for instructions and cautions.
8	PGM-FI malfunction indicator lamp (red)	Flashes when there is any abnormality in the PGM-FI (Programmed Fuel Injection) system. Should also light for a few seconds and then go off when the ignition switch is turned ON and the engine stop switch is in the RUN position. If the indicator comes on at any other time, reduce speed and take your motorcycle to a Honda dealer as soon as possible. <i>Lamp Check.</i>
9	neutral indicator (green)	Lights when the transmission is in neutral.
10	fuel gauge	Shows the approximate fuel supply available. At F (Full), the fuel tank capacity including reserve is: 10,0 l (2,64 US gal) When the gauge needle first points to E (Empty), refill the tank as soon as possible. At E there is: 2,1 l (0,55 US gal)

Ignition Switch

The ignition switch (1) is used for starting and stopping the engine (page 36) and to lock the steering for theft prevention (page 44). Insert the key and turn it to the right for the ON position. Push down on the key and turn it to the left to the LOCK (steering lock) position.

Key Position	Function
ON	Electrical circuits on.
OFF	No electrical circuits function.
LOCK (steering lock)	No electrical circuits function. Locks the steering head.

FRONT

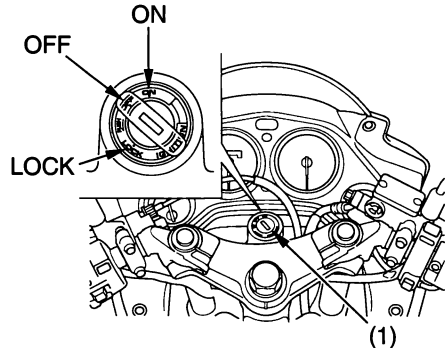

(1) ignition switch

To unlock the steering lock, insert the key and turn it to the right to the OFF position.

Controls & Features

Start Button



The start button (1) is used for starting the engine. Pushing the button in starts the engine. See *Starting Procedure*, page 34.

Engine Stop Switch



The engine stop switch (2) is used to stop the engine in an emergency. To operate, push the switch to the OFF position. The switch must be in the RUN position to start the engine, and it should normally remain in the RUN position even when the engine is OFF.

If your motorcycle is stopped with the ignition switch ON and the engine stop switch OFF, the headlight and taillight will remain on, resulting in battery discharge.

RIGHT HANDLEBAR

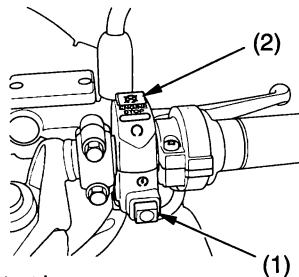

(1) start button

(2) engine stop switch



Headlight Dimmer Switch



The headlight dimmer switch (1) is used to change between the high and low beams of the headlight. To operate, turn the switch to HI for high beam, LO for low beam.

Turn Signal Switch

The turn signal switch (2) is used to signal a turn or a lane change. To operate, move the switch all the way in the proper direction and release it. The appropriate turn signal lights will start blinking. To cancel the light, push the switch in.

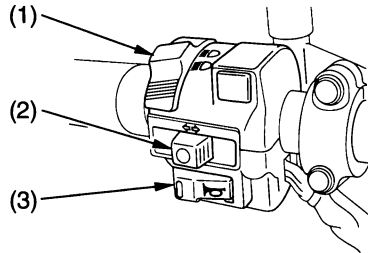
LEFT HANDLEBAR



- (1) headlight dimmer switch  HI
 LO
- (2) turn signal switch
- (3) horn button

Controls & Features

Horn Button



The horn is used to alert other motorists.
To operate, push the horn button (3).

Before Riding

Before each ride, you need to make sure you and your Honda are both ready to ride. To help get you prepared, this section discusses how to evaluate your riding readiness, what items you should check on your motorcycle, and adjustments to make for your comfort, convenience, or safety. This section also includes important information about loading.

Are You Ready to Ride ?	22
Protective Apparel.....	22
Rider Training	24
Is Your Motorcycle Ready to Ride ?	25
Pre-ride Inspection	25
Load Limit & Guidelines	28
Loading	28
Load Limits	29
Loading Guidelines	29

Are You Ready to Ride?

Before you ride your motorcycle for the first time, we urge you to:

- Read this owner's manual.
- Make sure you understand all the safety messages.
- Know how to operate all the controls.

Before each ride, be sure:

- You feel well and are in good physical and mental condition.
- You are wearing an approved motorcycle helmet (with chin strap tightened securely), eye protection, and other protective clothing.
- You don't have any alcohol or drugs in your system.

Make sure your passenger is ready to ride, too, and is wearing proper gear including a helmet.

If you are not riding with a passenger and want to carry an extra helmet, use a commercially-available elastic cord, strap, or net to secure the helmet to the seat.

Protective Apparel

For your safety, we strongly recommend that you always wear an approved motorcycle helmet, eye protection, boots, gloves, long pants, and a long-sleeved shirt or jacket whenever you ride. Although complete protection is not possible, wearing proper gear can reduce the chance of injury when you ride. Following are suggestions to help you choose the proper gear.

Are You Ready to Ride?

Helmets and Eye Protection

Your helmet is your most important piece of riding gear because it offers the best protection against head injuries. A helmet should fit your head comfortably and securely. A bright-colored helmet and reflective strips can make you more noticeable in traffic.

An open-face helmet offers some protection, but a full-face helmet offers more. Always wear a face shield or goggles to protect your eyes and help your vision.

⚠ WARNING

Not wearing a helmet increases the chance of serious injury or death in a crash.

Be sure you and your passenger always wear a helmet, eye protection, and other protective apparel when you ride.

Additional Riding Gear

In addition to a helmet and eye protection, we also recommend:

- Sturdy boots with non-slip soles to help protect your feet and ankles.
- Leather gloves to help protect your hands.

(cont'd)

Are You Ready to Ride?

- A motorcycle riding suit or jacket for comfort as well as protection. Bright-colored and reflective clothing can help make you more noticeable in traffic. Avoid loose clothes that could get caught on any part of your motorcycle.

Rider Training

Developing your riding skills is an on-going process. Even if you have ridden other motorcycles, take time to become familiar with how this motorcycle works and handles. Practice riding the motorcycle in a safe area to build your skills. Do not ride in traffic until you get accustomed to the motorcycle's controls, and feel comfortable with its size and weight.

We urge all riders to take a certified rider training course. New riders should start with the basic course, and even experienced riders will find the advanced course beneficial. For information about a training course nearest you, contact your local Honda dealer for details.

Is Your Motorcycle Ready to Ride?

Before each ride, it's important to inspect your motorcycle and make sure any problem you find is corrected. A pre-ride inspection is a must, not only for safety, but because having a breakdown, or even a flat tire, can be a major inconvenience.

WARNING

Improperly maintaining this motorcycle or failing to correct a problem before riding can cause a crash in which you can be seriously hurt or killed.

Always perform a pre-ride inspection before every ride and correct any problems.

Pre-ride Inspection

Check the following items before you get on the motorcycle:

- Tires & Wheels* Look at the tires. If a tire appears low, use an air pressure gauge to check its pressure. Also look for signs of excessive wear (page 103) or damage to the tires and wheels.
- Chain* Check the condition of the chain. Adjust slack and lubricate as needed (page 114).

(cont'd)

Is Your Motorcycle Ready to Ride?

*Leaks,
Loose
Parts*

Walk around your motorcycle and look for anything that appears unusual, such as a leak or loose cable.

Lights

Make sure the headlight, position light, brakelight, taillight, license light and turn signals are working properly.

If you are carrying a passenger or cargo, also check the following:

Load Limits Make sure you do not exceed the load limits (page 29).

Cargo Check that all cargo is secure.

Is Your Motorcycle Ready to Ride?

Check these items after you get on the motorcycle:

- Throttle* Rotate the throttle to check it moves smoothly without binding.
- Brakes* Pull the brake lever and press on the brake pedal to check that they operate normally.
- Indicators* Turn the ignition on and check for normal operation of the indicators (page 13).

If you haven't ridden the motorcycle in over a week, you should also check other items, such as the oil level and other fluids. See *Periodic Maintenance* (page 54). Periodic maintenance should also be done at least once a month, no matter how often you ride.

Remember, be sure to take care of any problem you find, or have your Honda dealer correct it before you ride.

Load Limits & Guidelines

Your motorcycle has been designed to carry you and one passenger. When you carry a passenger, you may feel some difference during acceleration and braking. But so long as you keep your motorcycle well-maintained, with good tires and brakes, you can safely carry loads within the given limits and guidelines.

However, exceeding the weight limit or carrying an unbalanced load can seriously impair your motorcycle's handling, braking, and stability. Non-Honda accessories, improper modifications, and poor maintenance can also reduce your safety margin.

Loading

How much weight you put on your motorcycle, and how you load it, are important to your safety. Anytime you ride with a passenger or cargo, you should be aware of the following information.

⚠ WARNING

Overloading or improper loading can cause a crash and you can be seriously hurt or killed.

Follow all load limits and other loading guidelines in this manual.

Load Limits

Following are the load limits for your motorcycle:

maximum weight capacity:

170 kg (375 lbs)

includes the weight of the rider,
passenger, all cargo, and all accessories.

maximum cargo weight:

8 kg (18 lbs)

includes following maximum
compartment weights:

rear compartment: 3.0 kg (6.6 lbs)

The weight of added accessories will reduce the maximum cargo weight you can carry.

Loading Guidelines

Your motorcycle is primarily intended for transporting you and a passenger. You may wish to secure a jacket or other small items to the seat when you are not riding with a passenger.

If you wish to carry more cargo, check with your Honda dealer for advice, and be sure to read the information regarding accessories on page 5.

Improperly loading your motorcycle can affect its stability and handling. Even if your motorcycle is properly loaded, you should ride at reduced speeds and never exceed 130 km/h (80 mph) when carrying cargo.

Load Limits & Guidelines

Follow these guidelines whenever you carry a passenger or cargo:

- Check that both tires are properly inflated (page 101).
- To prevent loose items from creating a hazard, make sure that all cargo is tied down securely before you ride.
- Place cargo weight as low and close to the center of your motorcycle as possible.
- Balance cargo weight evenly on both sides.

Basic Operation & Riding

This section gives basic riding instructions, including how to start and stop your engine, and how to use the throttle, clutch, and brakes. It also provides important information on riding with a passenger or cargo.

To protect your new engine and enjoy optimum performance and service life, refer to Break-in Guidelines (page 174).

To protect the catalytic converter in your motorcycle's exhaust system, avoid extended idling and the use of leaded gasoline.

Safe Riding Precautions	32
Starting & Stopping the Engine	33
Preparation.....	33
Starting Procedure	34
Flooded Engine.....	35
Bank Angle Sensor Ignition Cut-off System.....	35
How to Stop the Engine	36
Shifting Gears.....	37
Braking	39
Parking.....	41
Theft-Prevention Tips	44
Riding with a Passenger or Cargo.....	45

Safe Riding Precautions

Before riding your motorcycle for the first time, please review the *Motorcycle Safety* section beginning on page 1, and the *Before Riding* section beginning on page 21 .

Even if you have ridden other motorcycles, take time to become familiar with how this motorcycle works and handles. Practice in a safe area until you build your skills and get accustomed to the motorcycle's size and weight.

Make sure flammable materials such as dry grass or leaves do not come in contact with the exhaust system when riding, idling or parking your motorcycle. Refer to *Catalytic Converter*, page 181 .

Starting & Stopping the Engine

Always follow the proper starting procedure described below.

For your safety, avoid starting or operating the engine in an enclosed area such as a garage. Your motorcycle's exhaust contains poisonous carbon monoxide gas which can collect rapidly in an enclosed area and cause illness or death.

Your motorcycle can be started with the transmission in gear by pulling in the clutch lever before operating the starter.

Your motorcycle is equipped with a side stand ignition cut-off system. If the side stand is down — the engine cannot be started unless the transmission is in neutral. If the side stand is up — the engine can be started in neutral, or in gear with the

clutch lever pulled in. After starting with the side stand down, the engine will stop if the transmission is put in gear before raising the side stand.

Preparation

Before starting, insert the key, turn the ignition switch ON, and confirm the following:

- The transmission is in neutral (neutral indicator light ON).
- The engine stop switch is set to RUN.
- The PGM-FI malfunction indicator lamp (MIL) is OFF.

Starting & Stopping the Engine

Starting Procedure

This motorcycle has a fuel-injected with an automatic choke. Follow the procedure indicated below.

Any Air Temperature

- With the throttle completely closed, press the start button.

The engine will not start if the throttle is fully open (because the electronic control module cuts off the fuel supply).

Even if the engine coolant stays below the specified temperature, the cooling fan sometimes starts up running when you rev up the engine, but this is normal.

Starting & Stopping the Engine

Flooded Engine

If the engine fails to start after repeated attempts, it may be flooded with excess fuel. To clear a flooded engine:

1. Leave the engine stop switch set to RUN.
2. Open the throttle fully.
3. Press the start button for 5 seconds.
4. Follow the normal starting procedure.
5. If the engine starts, then open the throttle slightly if idling is unstable. If the engine does not start, wait 10 seconds, then follow steps 1 – 4 again.

If the engine still won't start, refer to *If Your Engine Quits or Won't Start*, page 139.

Bank Angle Sensor Ignition Cut-off System

Your motorcycle's banking (lean angle) sensor system is designed to automatically stop the engine and fuel pump if the motorcycle is overturned.

Before restarting the engine, you must turn the ignition switch to the OFF position and then back to ON. The engine will not restart until you perform this procedure.

Starting & Stopping the Engine

How to Stop the Engine

Normal Engine Stop

To stop the engine, shift into neutral and turn the ignition switch OFF.

The engine stop switch should normally remain in the RUN position even when the engine is OFF.

If your motorcycle is stopped with the engine stop switch OFF and the ignition switch ON, the headlight and taillight will remain on, resulting in battery discharge.

Emergency Engine Stop

To stop the engine in an emergency, use the engine stop switch. To operate, press the switch to the OFF position.

Shifting Gears

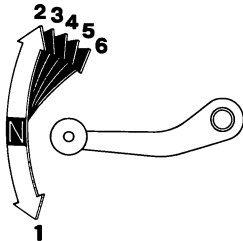

shifting pattern

Your motorcycle has six forward gears in a one-down, five-up shift pattern which is coordinated with a cable-operated clutch system.

Learning when to shift gears comes with experience. Keep the following tips in mind:

- As a general rule, shift while moving in a straight line.

- Close the throttle and pull the clutch lever in completely before shifting. Improper shifting may damage the engine, transmission, and drive train.
- Learn to recognize the engagement point as you release the clutch lever. It is at this point the transmission of power to the rear wheel resumes.
- Upshift to a higher gear or reduce throttle before engine rpm (speed) gets too high. Learn the relationship between engine sound and the normal shifting points.
- Downshift to a lower gear before you feel the engine laboring (lugging) at low rpm.

(cont'd)

Shifting Gears

- Avoid downshifting to help slow your motorcycle when engine rpm is near its allowable maximum (near the tachometer red zone). In this situation, the rev limiter in the engine ignition control module may not prevent excessive engine speed which could damage the engine.
- To prevent transmission damage, do not coast or tow the motorcycle for long distances with the engine off.

Recommended Shift Points

Ride in the highest gear that lets the engine run and accelerate smoothly. This will give you good fuel economy and effective emissions control. When changing gears under normal conditions, use these recommended shift points:

Shifting Up:

From 1st to 2nd:	20 km/h (12 mph)
From 2nd to 3rd:	30 km/h (19 mph)
From 3rd to 4th:	40 km/h (25 mph)
From 4th to 5th:	50 km/h (31 mph)
From 5th to 6th:	60 km/h (37 mph)

Shifting Down:

From 6th to 5th:	45 km/h (28 mph)
From 5th to 4th:	35 km/h (22 mph)
From 4th to 3rd:	25 km/h (16 mph)

Pull the clutch lever in when speed drops below 15 km/h (9 mph), when engine roughness is evident, or when engine stalling is imminent; and shift down to 1st gear for acceleration.

Your motorcycle is equipped with disc braking systems which are hydraulically activated. Operating the brake lever applies the front disc brake. Depressing the brake pedal applies the rear disc brake.

As a general rule, the front braking system provides about 70 percent of total stopping power.

For full braking effectiveness, use both the pedal and lever simultaneously. Using both braking systems will stop your motorcycle faster with greater stability.

To slow or stop, apply the brake lever and brake pedal smoothly, while downshifting to match your speed.

Gradually increase braking as you feel the brakes slowing your speed. The increase in engine compression from downshifting will help slow your motorcycle.

To prevent stalling the engine, pull the clutch lever in before coming to a complete stop. For support, put your left foot down first, then your right foot when you are finished using the brake pedal.

Applying the brakes too hard may cause the wheels to lock and slide, reducing control of your motorcycle. If this happens, release the brake controls, steer straight ahead until you regain control, then reapply the brakes more gently.

Braking

When possible, reduce your speed or complete braking before entering a turn. Avoid braking or closing the throttle quickly while turning. Either action may cause one or both wheels to slip and reduce your control of your motorcycle.

Your ability to brake in a turn and to brake hard in an emergency situation are important riding skills. We suggest attending a certified rider training course to retain these skills.

When riding in wet or rainy conditions, or on loose surfaces, the ability to maneuver and stop will be reduced. All of your actions should be smooth under these conditions. Rapid acceleration, braking or turning may cause loss of control. For your safety, exercise extreme caution

when braking, accelerating or turning.

When descending a long, steep grade, use engine compression braking by downshifting, with intermittent use of both brakes. Continuous brake application can overheat the brakes and reduce their effectiveness.

Riding with your foot resting on the brake pedal or your hand on the brake lever may actuate the brakelight, giving a false indication to other drivers. It may also overheat the brakes, reducing effectiveness.

1. Look for a level parking area. If you can't park on a paved surface, make sure the ground surface is firm, especially under the side stand. If you must park on a hill, leave the transmission in gear and position the rear tire against the curb at a 45 degree angle.

Make sure flammable materials such as dry grass or leaves do not come in contact with the exhaust system when parking your motorcycle. Refer to *Catalytic Converter*, page 181.

2. Use the side stand to support the motorcycle while parked.
 - To lower the side stand, use your foot to guide it down. Remember that lowering the side stand with the transmission in gear will stop the engine, even if the clutch lever is pulled in. That is a function of the side stand ignition cut-off system.
 - Check that the side stand is down all the way so that the side stand ignition cut-off system (page 33) is activated.
 - If you have to park on a soft surface, insert something solid under the side stand for support.

(cont'd)

Parking

FRONT

To lock

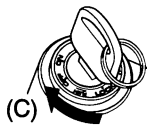
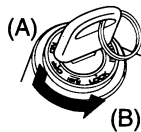

To unlock

(1) ignition key

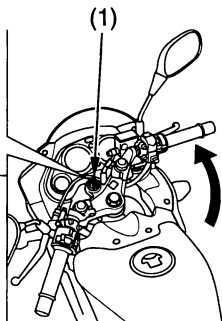

(A) push in
(B) turn to LOCK
(C) turn to OFF

- Use the steering lock, which locks the handlebar in place. Turn the handlebar all the way to the left. Push in on the ignition key (1) and turn it to LOCK. Remove the key.
(To unlock the steering lock, insert the key and turn it to the right to the OFF position.)

LEFT REAR

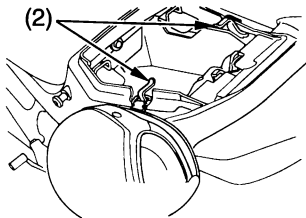

(2) holder hooks

4. Use the helmet holder to secure your helmet with your motorcycle:
 - Remove the rear seat (page 68).
 - Hang your helmet on the holder hooks (2).
 - Install the seat.

⚠ WARNING

Riding with a helmet attached to the holder can interfere with the rear wheel or suspension and could cause a crash in which you can be seriously hurt or killed.

Use the helmet holder only while parked. Do not ride with a helmet secured by the holder.

Parking

Theft-Prevention Tips

- Park your motorcycle in a locked garage whenever possible. If a garage isn't available, park in a concealed area or in a well-lit area with enough pedestrian traffic to discourage a thief.
 - Always take the ignition key with you.
 - Always use the steering lock (page 42), even if you're parking for just a minute or two. A thief can easily push an unlocked motorcycle to a waiting truck.
 - In addition to the steering lock, use a good quality anti-theft device made specifically to lock a motorcycle to a secure object.
- If you decide to use an anti-theft device, select one of good quality and be sure to follow the manufacturer's instructions.
 - Keep your owner's manual, current registration, and insurance information with your motorcycle. This will make it easier for the authorities to find you if your motorcycle is stolen and recovered.

Riding with a Passenger or Cargo

Your motorcycle is a high-performance sport model designed to carry you and one passenger. Whenever you add a passenger or cargo, you must be careful not to exceed the total load limits for this vehicle (*Load Limits*, page 29). Make sure your cargo is properly secured (*Loading Guidelines*, page 29).

Be aware that carrying a passenger or heavy cargo can affect acceleration, braking, and handling.

Before riding with a passenger, make sure your passenger is wearing the proper protective apparel (page 22). Also check that your passenger is not wearing any loose apparel that might get caught in the drive chain.

Tell your passenger to hold the grab rail or your waist, lean with you in the turns, and keep their feet on the passenger footpegs at all times, even when the motorcycle is stopped at a traffic light.

Servicing Your Honda

To help keep your motorcycle in good shape, this section includes a Maintenance Schedule for required service, a list of periodic checks you should perform at least once a month, and step-by-step instructions for specific maintenance tasks. You'll also find important safety precautions, information on fuels and oils, and tips for keeping your Honda looking great.

For information about replacing fuses, see page 172.

Before You Service Your Honda

The Importance of Maintenance.....	50
Maintenance Safety.....	51
Important Safety Precautions.....	52
Periodic Maintenance.....	54
Maintenance Schedule	56
Maintenance Record.....	61

(cont'd)

Servicing Your Honda

Service Preparations

Maintenance Component Locations	63
Tool Kit.....	66
Owner's Manual Storage.....	67
Seat Removal.....	68

Service Procedures

Fluids & Filters

Fuel	70
Engine Oil.....	73
Coolant.....	81
Crankcase Breather.....	85

Engine

Throttle	86
Clutch System.....	87
Spark Plug.....	91

Chassis

Brakes	95
Tires	101
Side Stand	108
Drive Chain.....	109

Electrical

Battery.....	116
--------------	-----

Appearance Care	121
-----------------------	-----

Servicing Your Honda

The following table summarizes the three types of inspections and servicing recommendations for your motorcycle. Both the pre-ride inspection and the scheduled maintenance at the recommended intervals are necessary to assure safe and dependable performance. The periodic checks provide additional confidence in your motorcycle's performance.

Type of Inspection/Service	Refer to page:	When Performed	Who Performs
Pre-ride Inspection	25	before every ride	you
Periodic Maintenance	54	monthly*	you
Maintenance Schedule	56	interval on schedule	your Honda dealer**

* more often if you ride frequently or long distances; or anytime you clean your motorcycle

** unless you have the proper tools and service data and are mechanically qualified

The Importance of Maintenance

Keeping your motorcycle well-maintained is absolutely essential to your safety. It's also a good way to protect your investment, get maximum performance, avoid breakdowns, and have more fun. A properly maintained motorcycle will also help to reduce air pollution.

Remember, proper maintenance is the owner's responsibility. Be sure to inspect your motorcycle before each ride, perform the periodic checks, and follow the Maintenance Schedule in this section.

WARNING

Improperly maintaining this motorcycle or failing to correct a problem before you ride can cause a crash in which you can be seriously hurt or killed.

Always follow the inspection and maintenance recommendations and schedules in this owner's manual.

If your motorcycle overturns or is involved in a crash, be sure your Honda dealer inspects all major parts, even if you are able to make some repairs.

This section includes instructions on how to perform some important maintenance tasks. If you have basic mechanical skills, you can perform many of these tasks with the tools provided with your motorcycle.

Other tasks that are more difficult and require special tools are best performed by professionals. Wheel removal should normally be handled only by a Honda technician or other qualified mechanic. Instructions are included in this manual only to assist in emergency service.

Some of the most important safety precautions follow. However, we cannot warn you of every conceivable hazard that can arise in performing maintenance. Only you can decide whether or not you should perform a given task.

WARNING

Failure to properly follow maintenance instructions and precautions can cause you to be seriously hurt or killed.

Always follow the procedures and precautions in this owner's manual.

Maintenance Safety

Important Safety Precautions

- Make sure the engine is off before you begin any maintenance or repairs. This will help eliminate several potential hazards:

Carbon monoxide poisoning from engine exhaust. Be sure there is adequate ventilation whenever you operate the engine.

Burns from hot motorcycle parts. Let the engine and exhaust system cool before touching.

Injury from moving parts. Do not run the engine unless instructed to do so.

- Read the instructions before you begin, and make sure you have the tools and skills required.
- To help prevent the motorcycle from falling over, park it on a firm, level surface, using the side stand or a maintenance stand to provide support.
- To reduce the possibility of a fire or explosion, be careful when working around gasoline. Use only non-flammable solvent, not gasoline, to clean parts. Keep cigarettes, sparks, and flames away from all fuel-related parts.

Remember that your Honda dealer knows your motorcycle best and is fully equipped to maintain and repair it. To ensure the best quality and reliability, use only new genuine Honda parts or their equivalents for repair and replacement. If you have the tools and skills required for additional maintenance jobs, you can purchase an official Honda Service Manual (page 186).

Periodic Maintenance

In addition to the regularly scheduled maintenance (page 56) and daily pre-ride inspection (page 25), consider performing the periodic checks on the following page at least once a month, even if you haven't ridden your motorcycle, or as often as once a week if you ride frequently or for long distances. It's a good idea to perform this maintenance any time you clean your motorcycle.

Check the odometer reading and perform any scheduled maintenance checks that are needed (page 56). Remember, more frequent checks may be needed for riding in severe conditions.

Periodic Maintenance

Tires & Wheels	<p>Check the air pressure with a gauge and add air if needed (page 101). Examine the tread for wear (page 103). Look closely for nails, embedded objects, cuts, and other types of damage (page 103). Roll your motorcycle so you can inspect the entire surface.</p> <p>Check the condition of the wheels.</p>
Fluids	<p>Check the levels of the engine oil (page 77), coolant (page 82), and brake fluid (page 96). Add the correct fluid as necessary, and investigate the cause of any low fluid level.</p>
Lights	<p>Make sure the headlight, brakelight, taillight, and turn signals are working properly.</p>
Freeplay	<p>Check the freeplay of the clutch lever (page 87) and throttle grip (page 86).</p>
Drive Chain	<p>Check condition, adjust slack, and lubricate as needed (page 114).</p>
Fuses	<p>Make sure you have a full supply of spare fuses.</p>
Nuts & Bolts	<p>Check the major fasteners and tighten as needed.</p>

Maintenance Schedule

The required Maintenance Schedule that follows specifies how often you should have your motorcycle serviced, and what things need attention. It is essential to have your motorcycle serviced as scheduled to maintain safe, dependable performance and proper emission control.

The service intervals in this Maintenance Schedule are based on average riding conditions. Some items will need more frequent service if you ride in unusually wet or dusty areas or at full throttle. Consult your Honda dealer for recommendations applicable to your individual needs and use.

Some items in the Maintenance Schedule can be performed with basic mechanical skills and hand tools. Procedures for these items are provided in this manual. Other items involve more extensive procedures and may require special training, tools, and equipment. We recommend that you have your Honda dealer perform these tasks unless you have advanced mechanical skills and the required tools and equipment. Procedures for such items in this schedule are provided in an official Honda Service Manual available for purchase (page 186).

Maintenance Schedule

If you do not feel capable of performing a given task or need assistance, remember that your Honda dealer knows your motorcycle best and is fully equipped to maintain and repair it. If you decide to do your own maintenance, use only genuine Honda parts or their equivalents for repair or replacement to ensure the best quality and reliability.

Perform the pre-ride inspection (page 25) and owner maintenance (page 56) at each scheduled maintenance period.

Each item on the maintenance schedule requires some mechanical knowledge. Certain items (particularly those marked * and **) may require more technical information and tools. Consult your Honda dealer.

- * Should be serviced by your Honda dealer, unless you have the proper tools and service data and are mechanically qualified. Refer to the official Honda Service Manual (page 186).
- ** In the interest of safety, we recommend these items be serviced only by your Honda dealer.

Maintenance Schedule

Summary of Maintenance Schedule Notes & Procedures:

NOTES:

1. At higher odometer readings, repeat at the frequency interval established here.
2. Service more frequently if the motorcycle is ridden in unusually wet or dusty areas.
3. Service more frequently if the motorcycle is ridden often at full throttle or in the rain.
4. Replace every 2 years.
Replacement requires mechanical skill.

Maintenance Procedures:

- I: inspect and clean, adjust, lubricate,
or replace, if necessary
- C: clean
- A: adjust
- L: lubricate
- R: replace

Maintenance Schedule

ITEM		FREQUENCY	NOTE	ODOMETER READING (Note 1)					
				× 1,000 mi	0.6	2.5	5	7.5	Refer to page
				× 1,000 km	1.0	4	8	12	
EMISSION RELATED ITEMS	*	FUEL LINE				I	I	I	—
	*	THROTTLE OPERATION				I	I	I	—
	*	AIR CLEANER	2			C	C	R	—
		CRANKCASE BREATHER	3			C	C	C	85
		SPARK PLUG				I	R	I	91
	*	VALVE CLEARANCE			I	I	I	I	—
		ENGINE OIL			INITIAL = 1,000km (600mi) or 1 month : R REGULAR = EVERY 4,000km (2,500mi) or 6 months : R				73
	**	ENGINE OIL STRAINER SCREEN						C	—
		RADIATOR COOLANT	4				I		81
	*	COOLING SYSTEM					I		—

- * Should be serviced by your Honda dealer, unless you have the proper tools and service data and are mechanically qualified. Refer to the official Honda Service Manual (page 186).
- ** In the interest of safety, we recommend these items be serviced only by your Honda dealer.

Maintenance Schedule

ITEM		FREQUENCY	NOTE	ODOMETER READING (Note 1)					Refer to page
				× 1,000 mi	0.6	2.5	5	7.5	
				× 1,000 km	1.0	4	8	12	
NON-EMISSION RELATED ITEMS		DRIVE CHAIN		EVERY 800km (500mi) I,L					109
		BRAKE FLUID	4						96
		BRAKE PAD WEAR							99
		BRAKE SYSTEM							95
	*	BRAKE LIGHT SWITCH							—
	*	HEADLIGHT AIM							—
		CLUTCH SYSTEM							87
		SIDE STAND							108
	*	SUSPENSION							—
	*	NUTS, BOLTS, FASTENERS							—
	**	WHEELS/TIRES							—
	**	STEERING HEAD BEARINGS							—

- * Should be serviced by your Honda dealer, unless you have the proper tools and service data and are mechanically qualified. Refer to the official Honda Service Manual (page 186).
- ** In the interest of safety, we recommend these items be serviced only by your Honda dealer.

Maintenance Record

Keeping an accurate maintenance record will help ensure that your motorcycle is properly maintained. Retain detailed receipts to verify the maintenance was performed. If the motorcycle is sold, these receipts should be transferred with the motorcycle to the new owner. Make sure whoever performs the maintenance completes this record. All scheduled maintenance, including the 1,000 km (600 mile) initial maintenance, is considered a normal owner operating cost and will be charged for by your dealer. Use the space under Notes to record anything you want to remind yourself about or mention to your dealer.

km (Miles)	Odometer	Date	Performed By:	Notes
1,000 (600)				
4,000 (2,500)				
8,000 (5,000)				
12,000 (7,500)				
16,000 (10,000)				

Maintenance Record

km (Miles)	Odometer	Date	Performed By:	Notes
20,000 (12,500)				
24,000 (15,000)				
28,000 (17,500)				
32,000 (20,000)				
36,000 (22,500)				
40,000 (25,000)				
44,000 (27,500)				
48,000 (30,000)				

Maintenance Component Locations

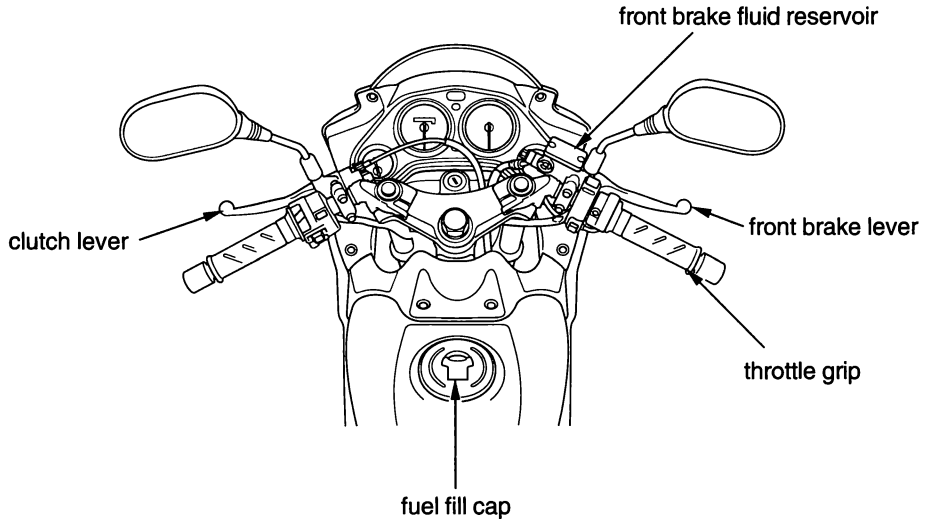

Maintenance Component Locations

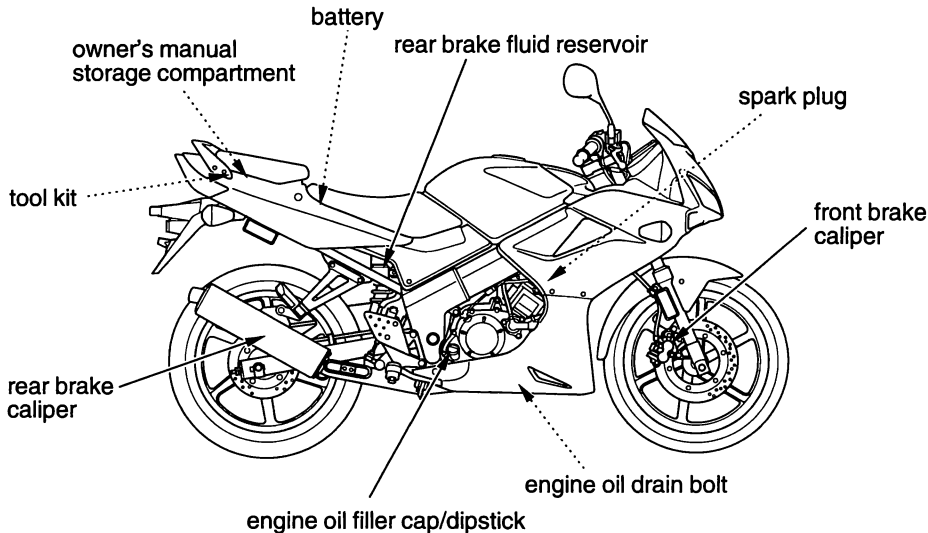

Maintenance Component Locations

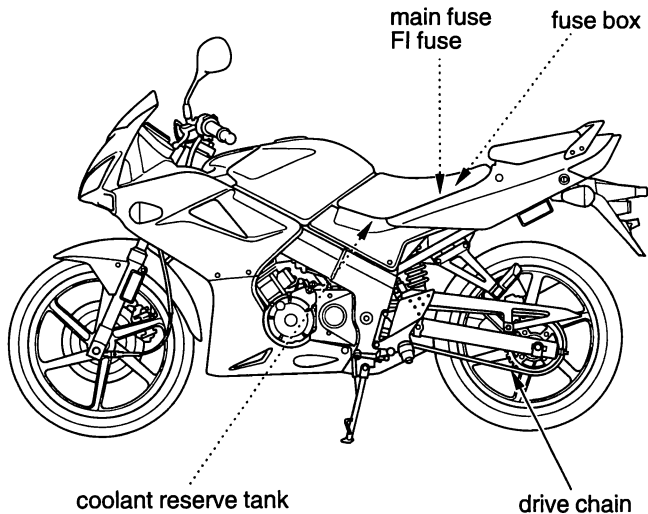

Tool Kit

The tool kit (1) is stored under the rear seat (page 68).

An optional, larger tool kit may be available. Check with your Honda dealer's parts department.

UNDER REAR SEAT

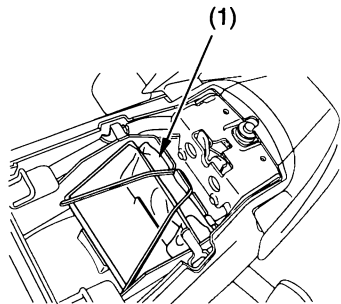

(1) tool kit

Owner's Manual Storage

Your motorcycle provides storage for the owner's manual so you'll have it with you for easy reference. Store your owner's manual (and other documents) in the plastic storage bag (1) in the owner's manual storage compartment (2) under the rear seat (page 68).

Be careful not to flood this area when washing your motorcycle.

UNDER REAR SEAT

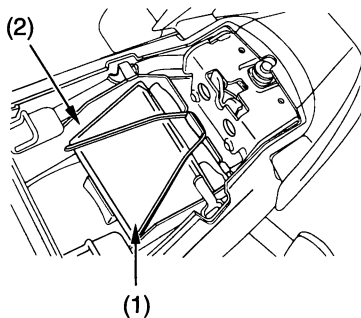

- (1) storage bag
- (2) owner's manual storage compartment

Seat Removal

Refer to *Safety Precautions* on page 52 .

The seat must be removed for battery maintenance and fuse maintenance, to use the helmet holder, or to access the tool kit and owner's manual.

Rear Seat Removal

To remove the rear seat (1), insert the ignition key (2) into the seat lock (3). Turn it clockwise, then pull the rear seat up and back.

To install the rear seat, insert the prongs (4) into the seat hooks (5), and then push down on the rear of the rear seat.

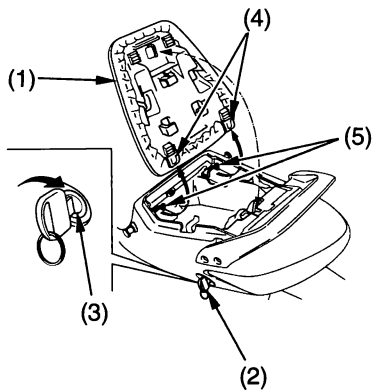

(1) rear seat
(2) ignition key
(3) seat lock

(4) prongs
(5) seat hooks

Seat Removal

Front Seat Removal

To remove the front seat (1), remove the rear seat (page 68). Remove the mounting bolt (2) and collar (3), and then pull the seat up and back.

To install the front seat, insert the tabs (4) into the recess under the frame and tighten the mounting bolt securely.

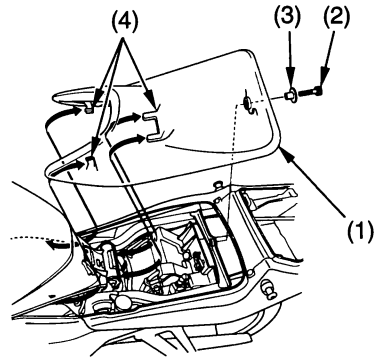

(1) front seat
(2) mounting bolt

(3) collar
(4) tabs

Fuel

Refer to *Safety Precautions* on page 52 .

Fuel Recommendation

type	unleaded
pump octane number	86 (or higher)

We recommend that you use unleaded fuel because it produces fewer engine deposits and extends the life of exhaust system components.

The use of leaded gas will damage the catalytic converter.

Your engine is designed to use any gasoline that has a pump octane number of 86 or higher. Gasoline pumps at service stations normally display the pump octane number. For information on the use of oxygenated fuels, see page 182 .

Use of lower octane gasoline can cause persistent “pinging” or “spark knock” (a loud rapping noise) which, if severe, can lead to engine damage. Light pinging experienced while operating under a heavy load, such as climbing a hill, is no cause for concern.

If pinging or spark knock occurs at a steady engine speed under normal load, change brands of gasoline. If pinging or spark knock persists, consult your Honda dealer.

Never use stale or contaminated gasoline or an oil/gasoline mixture. Avoid getting dirt, dust, or water in the fuel tank.

Fuel Capacity

Fuel tank capacity:
10,0 l (2,64 US gal)

The tank should be refilled as soon as possible when the fuel indicator comes on.

Refueling Procedure

Refer to *Safety Precautions* on page 52 .

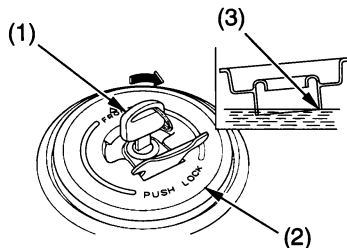

- (1) ignition key (3) filler neck
(2) fuel fill cap

1. Insert the ignition key (1) in the fuel fill cap (2) and turn it clockwise.

(cont'd)

Fuel

2. Open the cap.
3. Add fuel until the level reaches the bottom of the filler neck (3). Avoid overfilling the tank. There should be no fuel in the filler neck.

⚠ WARNING

Gasoline is highly flammable and explosive. You can be burned or seriously injured when handling fuel.

- Stop the engine and keep heat, sparks and flame away.
- Handle fuel only outdoors.
- Wipe up spills immediately.

4. After refueling, align the latch in the cap with the slot in the filler neck. Push the cap into the filler neck until it snaps and locks.
5. Remove the ignition key from the cap.

Engine oil quality is a major factor that affects both the performance and the service life of the engine.

Using the proper oil (page 74), and regularly checking, adding, and changing oil will help extend your engine's life. Even the best oil wears out. Changing oil helps get rid of dirt and deposits in the engine. Operating the engine with old or dirty oil can damage your engine. Running the engine with insufficient oil can cause serious damage to the engine and transmission.

Change the engine oil as specified in the maintenance schedule on page 59.

When running in very dusty conditions, oil changes should be performed more frequently than specified in the maintenance schedule.

Engine Oil

Oil Recommendation

API classification	SG or higher except oils labeled as energy conserving on the circular API service label
viscosity (weight)	SAE 10W-30
JASO T 903 standard	MA

suggested oil*

Pro Honda GN4 4-stroke oil, or Honda 4-stroke oil, or an equivalent motorcycle oil.

- * Suggested oils are equal in performance to SJ oils that are not labeled as energy conserving on the circular API service label.

- Your motorcycle does not need oil additives. Use the recommended oil.
- Do not use oils with graphite or molybdenum additives. They may adversely affect clutch operation.
- Do not use API SH or higher oils displaying a circular API “energy conserving” service label on the container. They may affect lubrication and clutch performance.



NOT RECOMMENDED



OK

- Do not use non-detergent, vegetable, or castor based racing oils.

Other viscosities shown in the following chart may be used when the average temperature in your riding area is within the indicated range.

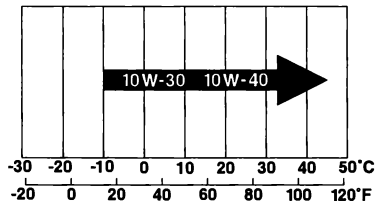

Engine Oil

JASO T 903 standard

The JASO T 903 standard is an index for engine oils for 4-stroke motorcycle engines.

There are two classes: MA and MB.

Oil conforming to the standard is labeled on the oil container. For example, the following label shows the MA classification.

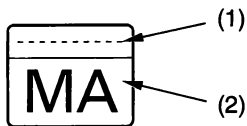

PRODUCT MEETING JASO T 903
COMPANY GUARANTEEING THIS MA PERFORMANCE:

- (1) code number of the sales company of the oil
- (2) oil classification

Checking & Adding Oil

Refer to *Safety Precautions* on page 52 .

RIGHT SIDE

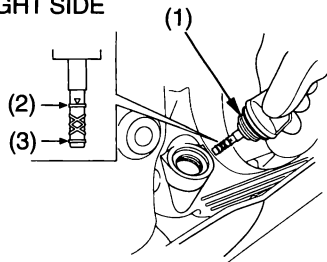

(1) oil filler cap/dipstick (3) lower level mark
(2) upper level mark

1. Park your motorcycle on its side stand on a firm, level surface.

2. Start the engine and let it idle for 3–5 minutes.
3. Stop the engine and wait 2–3 minutes.
4. Remove the oil filler cap/dipstick (1) and wipe it clean.
5. Hold the motorcycle in an upright position.
6. Insert the oil filler cap/dipstick until it seats, but don't screw it in.

(cont'd)

Engine Oil

7. Remove the oil filler cap/dipstick and check the oil level.
 - If the oil is at or near the upper level mark (2) — you do not have to add oil.
 - If the oil is below or near the lower level mark (3) — add the recommended oil until it reaches the upper level mark. (Do not overfill.)
8. Reinstall the oil filler cap/dipstick.
9. Check for oil leaks.

Changing Engine Oil

Refer to *Safety Precautions* on page 52 .

This procedure requires mechanical skill and professional tools such as a torque wrench, as well as a means for disposing of the drained fluid (page 135). If you do not have the skills or the tools, see your Honda dealer.

Drain the Engine Oil:

1. Park the motorcycle on its side stand on a firm, level surface.
2. If the engine is cold, start it and let it idle for 3–5 minutes. Turn the engine off. Wait 2–3 minutes for the oil to settle.
3. Place a drain pan under the engine oil drain bolt (1).
4. To drain the oil, remove the oil filler cap/dipstick, engine oil drain bolt, and sealing washer (2).

RIGHT FRONT, UNDER ENGINE

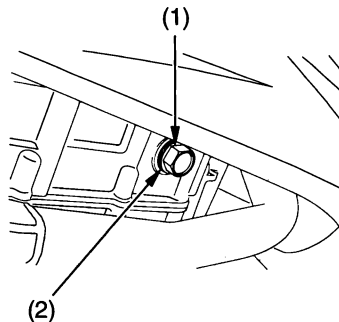

- (1) engine oil drain bolt
(2) sealing washer

(cont'd)

Engine Oil

5. Pour the drained oil into a suitable container and dispose of it in an approved manner (page 135).

NOTICE

Improper disposal of drained fluids is harmful to the environment.

6. Check the condition of the sealing washer on the engine oil drain bolt. Replace the washer every other time the oil is changed.
Install the engine oil drain bolt and tighten it to the specified torque:
25 N·m (18 lbf·ft)

Add Engine Oil:

7. Fill the crankcase with the recommended oil (page 74), approximately:
1,0 ℓ (1,1 US qt)
8. Install the oil filler cap/dipstick securely.
9. Start the engine and let it idle for 3–5 minutes.
10. Stop the engine and wait 2–3 minutes.
11. Hold the motorcycle upright and check that the oil level is at the upper level mark on the oil filler cap/dipstick (page 77).
12. Check that there are no oil leaks.

If a torque wrench is not used for installation, see your Honda dealer as soon as possible to verify proper assembly.

Your motorcycle's liquid cooling system dissipates engine heat through the coolant jacket that surrounds the cylinder and cylinder head.

Maintaining the coolant will allow the cooling system to work properly and prevent freezing, overheating, and corrosion.

Coolant Recommendation

Use Pro Honda HP coolant or an equivalent high quality ethylene glycol antifreeze containing corrosion protection inhibitors specifically recommended for use in aluminum engines. Check the antifreeze container label.

Use only distilled water as a part of the coolant solution. Water that is high in mineral content or salt may be harmful to the aluminum engine.

NOTICE

Using coolant with silicate inhibitors may cause premature wear of water pump seals or blockage of radiator passages. Using tap water may cause engine damage.

The factory provides a 50/50 solution of antifreeze and water in this motorcycle. This coolant solution is recommended for most operating temperatures and provides good corrosion protection.

Coolant

Decreasing the concentration of antifreeze to less than 40% will not provide proper corrosion protection.

Increasing the concentration of antifreeze is not recommended because it decreases cooling system performance. Higher concentrations of antifreeze (up to 60%) should only be used to provide additional protection against freezing. Check the cooling system frequently during freezing weather.

Checking & Adding Coolant

Refer to *Safety Precautions* on page 52 .

LEFT SIDE

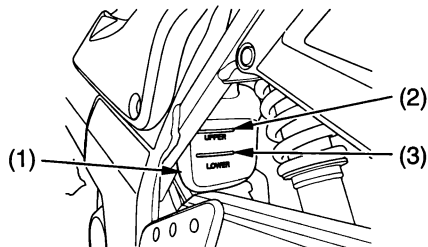

- (1) reserve tank
- (2) UPPER level mark
- (3) LOWER level mark

1. With the engine at normal operating temperature, check the coolant level in the reserve tank (1). It should be between the UPPER (2) and LOWER (3) level marks.

If the reserve tank is empty, or if coolant loss is excessive, check for leaks and see your Honda dealer for repair.

2. Remove the front seat (page 69).

UNDER FRONT SEAT

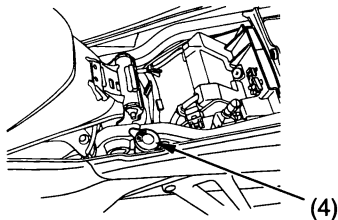

- (4) reserve tank cap

3. Remove the reserve tank cap (4).
Always add coolant to the reserve tank.
Do not attempt to add coolant by removing the radiator cap.
4. Add coolant to the reserve tank as required to bring the coolant level to the UPPER level mark.

Coolant

Coolant Replacement

Refer to *Safety Precautions* on page 52 .

Coolant should be replaced by your Honda dealer, unless you have the proper tools and service data and are mechanically qualified. Refer to the official Honda Service Manual (page 186).

⚠ WARNING

Removing the radiator cap while the engine is hot can cause the coolant to spray out, seriously scalding you.

Always let the engine and radiator cool down before removing the radiator cap.

To properly dispose of drained coolant, refer to *You & the Environment*, page 135 .

NOTICE

Improper disposal of drained fluids is harmful to the environment.

Crankcase Breather

Refer to *Safety Precautions* on page 52 .

Service the crankcase breather more frequently if your motorcycle is ridden in the rain or often at full throttle. Service the breather if you can see deposits in the transparent section of the drain tube.

Draining

RIGHT SIDE

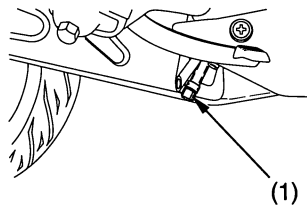

(1) crankcase breather tube plug

1. Place a drain pan under the crankcase breather tube plug (1).
2. Remove the plug to drain the deposits in the tube.
3. Reinstall the crankcase breather tube plug.

Throttle

Throttle Freeplay

Refer to *Safety Precautions* on page 52 .

RIGHT HANDLEBAR

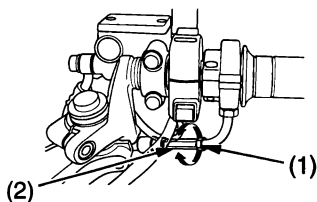

(1) lock nut (2) adjuster

Inspection

Check freeplay at the throttle grip flange.

Freeplay:

2—6 mm (1/16—1/4 in)

If necessary, adjust to the specified range.

Adjustment

1. Loosen the lock nut (1).
2. Turn the adjuster (2).
3. After adjustment, check for smooth rotation of the throttle grip from fully closed to fully open in all steering positions.

Throttle Inspection

Refer to *Safety Precautions* on page 52 .

1. Check that the throttle assembly is positioned properly and the securing bolts are tight.
2. Check for smooth rotation of the throttle from fully open to fully closed in all steering positions. If there is a problem, see your Honda dealer.

Clutch System

Your motorcycle's manually-activated, wet, multiplate clutch is part of the primary drive system. Proper freeplay adjustment allows a smooth, gradual engagement when shifting gears.

Improper freeplay adjustment can cause premature clutch wear.

Clutch Freeplay

Refer to *Safety Precautions* on page 52.

LEFT HANDLEBAR

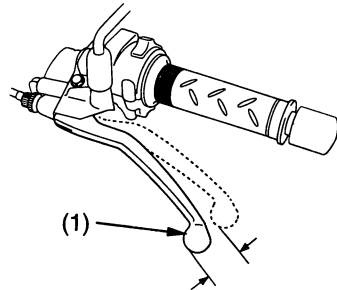

(1) clutch lever

(cont'd)

Clutch System

Inspection

Check freeplay:

10 – 20 mm (3/8 – 13/16 in)

If necessary, adjust to the specified range.

Upper Adjustment

Attempt adjustment with the upper clutch cable adjuster first.

LEFT HANDLEBAR

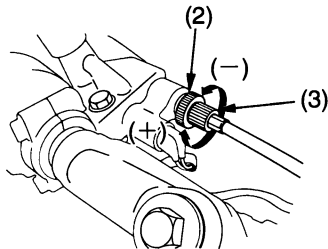

(2) upper lock nut

(3) upper clutch cable adjuster

(+) increase freeplay

(-) decrease freeplay

1. Loosen the upper lock nut (2).
2. Turn the upper clutch cable adjuster (3) to obtain the specified freeplay.
3. Tighten the upper lock nut and check the freeplay again.

Clutch System

Lower Adjustment

If the upper clutch cable adjuster is threaded out near its limit — or the correct freeplay cannot be obtained — attempt adjustment with the lower clutch cable adjuster.

RIGHT SIDE

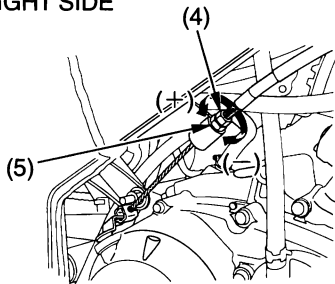

(4) lock nut (+) increase freeplay
(5) adjusting nut (-) decrease freeplay

4. Loosen the upper lock nut (2) and turn the upper clutch cable adjuster (3) all the way in (to provide maximum freeplay). Tighten the upper lock nut.
5. Loosen the lower lock nut (4).
6. Turn the lower adjusting nut (5) to obtain the specified freeplay.
7. Tighten the lower lock nut and check the adjustment.

(cont'd)

Clutch System

8. Start the engine, pull the clutch lever in, and shift into gear. Make sure the engine does not stall and the motorcycle does not creep. Gradually release the clutch lever and open the throttle. Your motorcycle should move smoothly and accelerate gradually.

If you cannot get proper adjustment, or the clutch does not work properly, the cable or clutch friction discs may be worn. See your Honda dealer or refer to the official Honda Service Manual (page 186).

Other Inspections & Lubrication

- Check that the clutch lever assembly is positioned properly and the securing bolts are tight.
- Check the clutch cable for kinks or signs of wear. If necessary, have it replaced.
- Lubricate the clutch cable with a commercially-available cable lubricant to prevent premature wear and corrosion.

Spark Plug Recommendation

standard spark plug	CR8E (NGK) or U24ESR-N (DENSO)
for extended high speed riding	CR9E (NGK) or U27ESR-N (DENSO)

Use only the recommended type of spark plugs in the recommended heat range.

NOTICE

Using spark plugs with an improper heat range can cause engine damage.

Spark Plug

Spark Plug Inspection & Replacement

Refer to *Safety Precautions* on page 52 .

1. Clean any dirt from around the spark plug base.
2. Disconnect the spark plug cap (1).
Take care to avoid damaging the spark plug wire when disconnecting the cap.
3. Using a spark plug wrench (2), remove the spark plug.

RIGHT SIDE

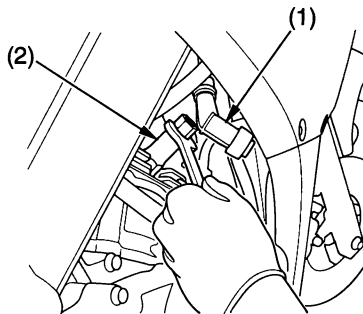

- (1) spark plug cap
(2) spark plug wrench

Spark Plug

4. Inspect the electrodes and center porcelain for deposits, corrosion, or carbon fouling. If the corrosion or deposits are heavy, replace the plug. Clean a carbon or wet-fouled plug with a plug cleaner, if available, or a wire brush.
5. Check the spark plug gap (3) of each new plug, using a wire-type feeler gauge. If adjustment is necessary, bend the side electrode (4) carefully.

The gap should be:

0.70–0.80 mm (0.028–0.031 in)

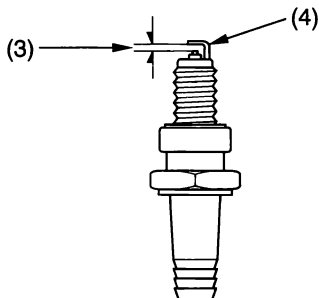

(3) spark plug gap (4) side electrode

6. With the plug washer attached, thread the spark plug in by hand to prevent cross-threading.

(cont'd)

Spark Plug

7. Tighten each spark plug:
 - If the old plug is good:
 - 1/8 turn after it seats.
 - If installing a new plug, tighten it twice to prevent loosening:
 - a) First, tighten the plug:
 - NGK: 1/2 turn after it seats.
 - DENSO: 3/4 turn after it seats.
 - b) Then loosen the plug.
 - c) Next, tighten the plug again:
 - 1/8 turn after it seats.

NOTICE

An improperly tightened spark plug can damage the engine. If a plug is too loose, a piston may be damaged. If a plug is too tight, the threads may be damaged.

8. Reinstall the spark plug cap. Take care to avoid pinching any cables or wires.

The hydraulic braking systems on your motorcycle dissipate the heat generated by the friction of the brake pads on the brake discs as the wheels are slowed.

As the brake pads wear, the brake fluid level will drop. A leak in the system will also cause the level to drop.

Frequently inspect the system to ensure there are no fluid leaks. Periodically inspect the brake fluid level and the brake pads for wear.

If the brake lever or brake pedal freeplay does not feel within the normal range while riding, check the brake pads for wear (page 99). Worn pads should be replaced. If the pads are not worn beyond the recommended limit, there is probably air in the brake system. See your Honda dealer to have the air bled from the system.

Brakes

Brake Fluid Recommendation

brake fluid	Honda DOT 3 or 4 Brake Fluid
----------------	---------------------------------

The recommended brake fluid is Honda DOT 3 or DOT 4 Brake Fluid, or any brake fluid of equal quality and performance. Use fresh brake fluid from a sealed container. Be sure to read the label before opening the sealed container. An opened container may be contaminated or may have absorbed moisture from the air.

Fluid Level Inspection

Refer to *Safety Precautions* on page 52 .

If your inspection indicates a low fluid level, have your Honda dealer add the recommended brake fluid.

Do not add or replace brake fluid, except in an emergency. If you do add fluid, have your Honda dealer check the system as soon as possible.

NOTICE

Brake fluid can damage plastic and painted surfaces. Handle with care.

Wipe up spills immediately. Avoid contact with skin or eyes. In case of contact, wash thoroughly and call a doctor immediately if it contacts your eyes.

Front Brake

RIGHT HANDLEBAR

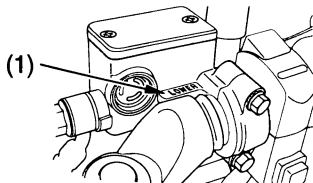

(1) LOWER level mark

1. Place your motorcycle in an upright position on a firm, level surface.
2. Check the fluid level.

It should be above the LOWER level mark (1).

If the level is at or below the LOWER level mark, check the brake pads for wear (page 99).

Worn pads should be replaced. If the pads are not worn beyond the recommended limit, have your brake system inspected for leaks.

Other Inspections

- Make sure there are no fluid leaks.
- Check for deterioration or cracks in the hoses and fittings.

Brakes

Rear Brake RIGHT SIDE

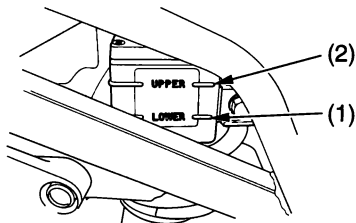

- (1) LOWER level mark
(2) UPPER level mark

1. Place your motorcycle in an upright position on a firm, level surface.
2. Check the fluid level. It should be between the UPPER (2) and LOWER (1) level marks. If the level is at or below the LOWER level mark, check the brake pads for wear (page 99).

Worn pads should be replaced. If the pads are not worn beyond the recommended limit, have your brake system inspected for leaks.

Other Inspections

- Make sure there are no fluid leaks.
- Check for deterioration or cracks in the hoses and fittings.

Brake Pad Wear

Refer to *Safety Precautions* on page 52 .

Brake pad wear depends upon the severity of usage, the type of riding, and road conditions. Generally, the pads will wear faster on wet and dirty roads. Inspect the pads at each regular maintenance interval (page 60).

RIGHT FRONT

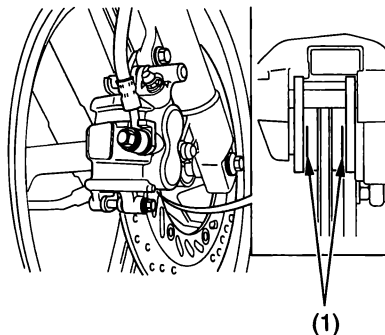

(1) wear indicator marks

(cont'd)

Brakes

RIGHT REAR

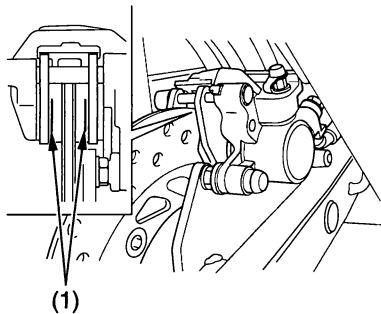

(1) wear indicator marks

Check the wear indicator mark (1) in each pad. If either pad is worn to the wear indicator mark, replace both pads as a set. See your Honda dealer for this service.

To safely operate your motorcycle, your tires must be the proper type and size, in good condition with adequate tread, and correctly inflated for the load you are carrying.

⚠ WARNING

Using tires that are excessively worn or improperly inflated can cause a crash in which you can be seriously hurt or killed.

Follow all instructions in this owner's manual regarding tire inflation and maintenance.

The following pages give detailed information on how and when to check your air pressure, how to inspect your tires

for wear and damage, and our recommendations for tire repair and replacement.

Air Pressure

Refer to *Safety Precautions* on page 52 .

Properly inflated tires provide the best combination of handling, tread life, and riding comfort. Generally, underinflated tires wear unevenly, adversely affect handling, and are more likely to fail from being overheated. Overinflated tires make your motorcycle ride harshly, are more prone to damage from road hazards, and wear unevenly.

Tires

We recommend that you visually check your tires before every ride and use an air pressure gauge to measure the air pressure at least once a month or any time you think the tires might be low. Even tires that are in good condition may lose one to two psi per month if not checked and adjusted regularly.

Tubeless tires have some degree of self-sealing ability if they are punctured. However, because leakage is often very slow, you should look closely for punctures whenever a tire is not fully inflated.

Always check air pressure when your tires are “cold” — after the motorcycle has been parked for at least three hours. If you check air pressure when your tires are

“warm” — even if your motorcycle has only been ridden for a few miles — the readings will be higher. If you let air out of warm tires to match the recommended cold pressures, the tires will be underinflated.

The recommended “cold” tire pressures are:

front	200 kPa (29 psi)
rear	225 kPa (33 psi)

Inspection

Refer to *Safety Precautions* on page 52.

Whenever you check the tire pressures, you should also look for:

- Bumps or bulges in the side of the tire or the tread. Replace any tire that has a bump or bulge.
- Cuts, slits, or cracks in the tires. Replace the tire if you can see fabric or cord.
- Nails or other foreign objects embedded in the side of the tire or tread.
- Excessive tread wear.

Also, if you hit a pothole or hard object while riding, pull to the side of the road as soon as you safely can and carefully inspect the tires for damage.

Tread Wear

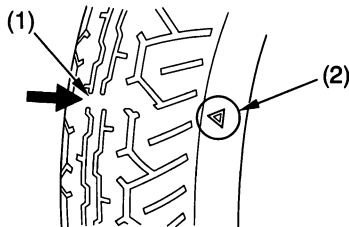

- (1) wear indicator
(2) wear indicator location mark

Tires

For the best performance, you should replace a tire before the tread depth at the center reaches the following limits:

front	1.5 mm (0.06 in)
rear	2.0 mm (0.08 in)

If the wear indicators are visible, replace the tire immediately as it is no longer safe.

Tire Repair

Refer to *Safety Precautions* on page 52 .

We strongly recommend that you replace, not repair, any tire that is punctured or damaged. As discussed below, a tire that is repaired, either temporarily or permanently, will have lower speed and performance limits than a new or undamaged tire.

A temporary repair can sometimes be made in an emergency situation.

However, since a temporary repair may not hold, you must ride very slowly, preferably without any cargo or passenger, and have the tire replaced or permanently repaired as soon as possible.

(For more information on temporary repairs, see *If You Have a Flat Tire*, page 144 .)

A permanent repair, such as an internal plug patch, can be made if a tire has only a small puncture in the tread area. With such a repair, you should not exceed 80 km/h (50 mph) for the first 24 hours, or 130 km/h (80 mph) at any time thereafter. In addition, you may not be able to safely carry as much weight. If you choose to have a tire repaired, be sure the repair work is performed by a professional and that the wheel is balanced before you ride.

If you have a tire professionally repaired at a non-Honda facility, we recommend that you have the work checked by your Honda dealer.

Tire Replacement

Refer to *Safety Precautions* on page 52 .

The tires that came on your motorcycle were designed to match the performance capabilities of your motorcycle and provide the best combination of handling, braking, durability, and comfort.

Tires

You should replace the tires with tires of the same size, load range, and speed rating as the originals.

WARNING

Installing improper tires on your motorcycle can affect handling and stability. This can cause a crash in which you can be seriously hurt or killed.

Always use the size and type of tires recommended in this owner's manual.

The recommended tires for your motorcycle are:

front	80/90-17M/C 44P IRC NR73s
rear	100/80-17M/C 52P IRC NR73s
type	bias-ply, tubeless

Whenever you replace a tire, remember:

- Have the wheel balanced after the tire is installed.
- Have the tire replaced by your Honda dealer if possible.

If you have a tire professionally replaced at a non-Honda facility, we recommend that you have the work checked by your Honda dealer.

Important Safety Reminders

- Do not install a tube inside a tubeless tire on this motorcycle. Excessive heat build-up can cause the tube to burst.
- Use only tubeless tires on this motorcycle. The rims are designed for tubeless tires, and during hard acceleration or braking, a tube-type tire could slip on the rim and cause the tire to rapidly deflate.
- Do not install a radial tire on this motorcycle. Mixing bias-ply and radial tires can adversely affect handling and stability.

Side Stand

Refer to *Safety Precautions* on page 52.

LEFT SIDE

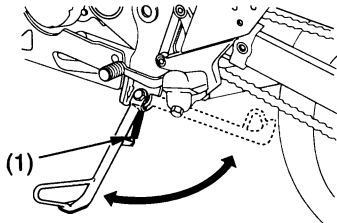

(1) side stand spring

- Check that the side stand assembly is working properly. If the side stand is stiff or squeaky, clean the pivot area and lubricate the pivot bolt with clean grease.

- Check the spring for damage or loss of tension.
- Check the side stand ignition cut-off system:
 1. Sit on the motorcycle and put the transmission in neutral.
 2. Raise the side stand.
 3. Start the engine.
 4. Pull the clutch lever in.
 5. Shift the transmission into gear.
 6. Lower the side stand all the way.

The engine should stop as you lower the side stand. If the engine doesn't stop, see your Honda dealer for service.

An endless (riveted master link) chain connects the countershaft and rear wheel sprockets. The O-ring chain uses rubber rings between the side plates of the pin and roller links to seal in the manufacturer-installed lubricating grease and keep out moisture and dirt.

The service life of the chain depends on proper lubrication and adjustment. Poor maintenance can cause premature wear or damage to the drive chain or sprockets.

The drive chain should be checked, adjusted, and lubricated as part of the pre-ride inspection (page 25).

Under severe usage, or when the motorcycle is ridden in unusually dusty or muddy areas, more frequent maintenance will be necessary.

Before servicing your drive chain, turn the engine OFF, lower the side stand, and check that your transmission is in neutral.

It is not necessary to remove or replace the drive chain to perform the recommended service in the Maintenance Schedule.

Drive Chain

Inspection

Refer to *Safety Precautions* on page 52.

1. Check slack in the lower drive chain
(1) run midway between the sprockets.
Drive chain slack should allow the following vertical movement by hand:
25–35 mm (1–1 3/8 in)
2. Check drive chain slack at several points along the chain. The slack should remain constant. If it isn't, some links may be kinked and binding. Lubricating the chain will often eliminate binding and kinking.

LEFT SIDE

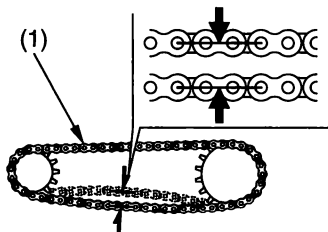

(1) drive chain

3. Inspect the drive chain for:
 - damaged rollers
 - dry or rusted links
 - kinked or binding links
 - excessive wear
 - improper adjustment
 - damaged or missing O-rings

Replace the drive chain (page 115) if it has damaged rollers, loose pins, or kinks that cannot be freed. Lubricate the drive chain (page 114) if it appears dry or shows signs of rust. Lubricate any kinked or binding links and work them free. Adjust chain slack if needed.

4. Inspect the front and rear wheel sprocket teeth for excessive wear or damage. If necessary, have your Honda dealer replace a worn sprocket.

damaged
sprocket
teeth

worn
sprocket
teeth

REPLACE

REPLACE

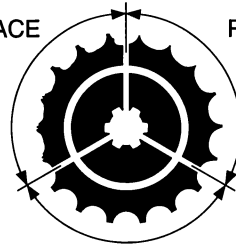

normal sprocket teeth
GOOD

NOTICE

Use of a new chain with worn sprockets will cause rapid chain wear.

Drive Chain

Wear Inspection

LEFT SIDE

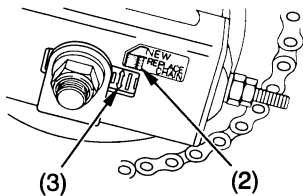

(2) red zone

(3) index line

Check the chain wear label when adjusting the chain. If the red zone (2) on the label aligns with the index lines (3) on both sides of the swingarm after the chain has been adjusted to the proper slack, the chain is excessively worn and must be replaced. The proper slack is:
25–35 mm (1–1 3/8 in)

The bottom part of the frame may be damaged by excessive drive chain slack of more than:

50 mm (1 15/16 in)

Adjustment

Refer to *Safety Precautions* on page 52 .

Drive chain slack should be checked and adjusted, if necessary, every 800 km (500 miles). When operated at sustained high speeds or under conditions of frequent rapid acceleration, the chain may require more frequent adjustments.

Drive Chain

LEFT SIDE

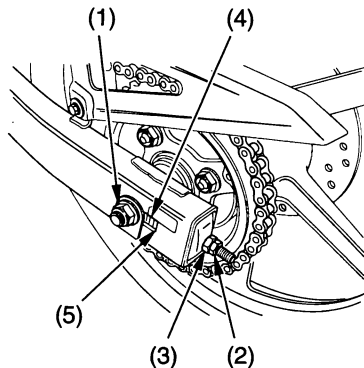

- | | |
|----------------------------------|------------------------------------|
| (1) rear axle nut | (4) index mark |
| (2) lock nut | (5) rear edge of
adjusting slot |
| (3) drive chain
adjusting nut | |

1. Place the motorcycle on its side stand with the transmission in neutral and the ignition switch OFF.
2. Loosen the rear axle nut (1).
3. Loosen the lock nuts (2) on both sides of the swingarm.
4. Turn both adjusting nuts (3) an equal number of turns until the correct drive chain slack is obtained. Turn the adjusting nuts clockwise to tighten the chain, or counterclockwise to provide more slack. Adjust the chain slack at a point midway between the drive sprocket and the rear wheel sprocket. Roll the motorcycle forward. Stop and place it on its side stand. Recheck chain slack. Chain slack should allow the following vertical movement by hand:
25–35 mm (1–1 3/8 in)

(cont'd)

Drive Chain

5. Check rear axle nut alignment by making sure the chain adjuster index marks (4) align with the rear edge (5) of the adjusting slots. Both marks should correspond. If the axle is misaligned, turn the right or left adjusting nut until the marks correspond on the rear edge of the adjusting slots and recheck chain slack.
6. Torque the rear axle nut to:
59 N·m (43 lbf·ft)
If a torque wrench is not used for this installation, see your Honda dealer as soon as possible to verify proper assembly. Improper assembly may lead to a loss of braking capacity.
7. Tighten the drive chain adjusting nuts lightly. Then, while holding the drive chain adjusting nuts with a wrench, tighten the drive chain lock nuts.

8. Recheck drive chain slack (page 112).

Lubrication

Refer to *Safety Precautions* on page 54.

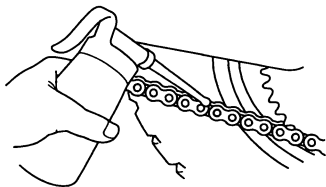

Lubricate every 800 km (500 miles) or sooner if chain appears dry. Lubricant: **SAE 80 or 90 gear oil**

Lubricate only with SAE 80 or 90 gear oil. Commercial chain lubricants may contain solvents which could damage the rubber O-rings.

Removal, Cleaning & Replacement

Refer to *Safety Precautions* on page 52 .

Your motorcycle has an endless (riveted master link) type chain. It should only be removed or replaced by your Honda dealer.

The O-rings can be damaged by steam cleaning, high pressure washers, and certain solvents.

1. Clean the side surfaces of the chain with a dry cloth. Use a high flashpoint solvent such as kerosene — not gasoline.

Do not brush the rubber O-rings. Brushing will damage them. Use of a solvent may also damage the O-rings.

2. Inspect the drive chain for possible wear or damage.

Replace the drive chain if it has damaged rollers, loose fitting links, damaged O-rings, or otherwise appears unserviceable.

Replacement Chain:

DID428VI3-124LE

Battery

Your motorcycle has a maintenance-free type battery. You do not have to check the battery electrolyte level or add distilled water as you would with a conventional-type battery.

NOTICE

Your battery is a maintenance-free type and can be permanently damaged if the cap strip is removed.

Electrical accessories use current from the battery — even when the ignition is OFF. Limited operation also allows the battery to discharge. If you have electrical accessories on your motorcycle — or do not ride frequently, we recommend that you charge the battery frequently (see *Battery Charging*, page 120).

If you do not expect to ride your motorcycle for at least two weeks, we recommend you remove the battery — or at least disconnect the battery cables (negative cable first).

If you plan to store your motorcycle, see *Battery Storage*, page 117 .

If your battery seems weak and/or is leaking electrolyte (causing slow starting or other electrical problems), see your Honda dealer.

WARNING: Battery posts, terminals and related accessories contain lead and lead compounds. **Wash your hands after handling.**

Battery Storage

Refer to *Safety Precautions* on page 52.

If you plan to store your motorcycle, we recommend you remove the battery and store it where it can be charged at least every 30 days to maintain its service life.

If you do not remove the battery, we recommend disconnecting the battery cables (negative cable first).

You will get the best storage results from removing the battery and slow (trickle) charging it every 30 days (see *Battery Charging*, page 120).

Before you remove the battery, be sure to read all the information that follows, as well as the information on the battery label.

WARNING

The battery gives off explosive hydrogen gas during normal operation.

A spark or flame can cause the battery to explode with enough force to kill or seriously hurt you.

Wear protective clothing and a face shield, or have a skilled mechanic do the battery maintenance.

Battery

The battery is located in the battery box below the front seat.

Removal

1. Make sure the ignition switch is OFF.
2. Remove the front seat (page 69).
3. Remove the clip (1) and open the battery cover (2).
4. Disconnect the negative (-) terminal lead (3) from the battery first, then disconnect the positive (+) terminal lead (4).
5. Pull the battery (5) out of the battery box (6).

UNDER FRONT SEAT

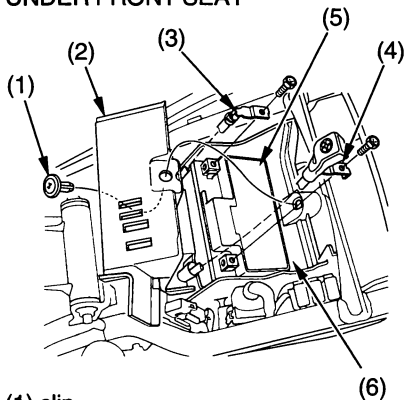

- (1) clip
- (2) battery cover
- (3) negative (-) terminal lead
- (4) positive (+) terminal lead
- (5) battery
- (6) battery box

6. Charge the battery (see following section), unless you have been riding regularly.
7. Store your battery in an easy-to-reach location off the floor, in an area protected from freezing temperatures and direct sunlight.
8. Clean the battery box after removing the battery for storage. Dry the battery box and, if paint is missing, re-paint the area.
9. Slow charge the battery (see following section) once every 30 days.

Installation

1. Reinstall in the reverse order of removal. Be sure to connect the positive (+) terminal first, then the negative (-) terminal.
2. Check all bolts and other fasteners are secure.
3. Install the seat.

Battery

Battery Charging

Refer to *Safety Precautions* on page 52.

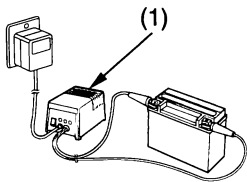

(1) “trickle” charger

Be sure to read the information that came with your battery charger and follow the instructions on the battery. Improper charging may damage the battery.

We recommend using a “trickle” charger (1) for home charging. These units can be left connected for long periods without risking damage to the battery. However, do not intentionally leave the charger connected longer than the time period recommended in the charger’s instructions.

Avoid using an automotive-type battery charger. An automotive charger can overheat a motorcycle battery and cause permanent damage.

Frequent cleaning and polishing will keep your Honda looking newer longer. Frequent cleaning also identifies you as an owner who values your motorcycle. A clean motorcycle is also easier to inspect and service.

General Recommendations

Refer to *Safety Precautions* on page 52 .

- To clean your motorcycle, you may use:
 - water
 - a mild, neutral detergent and water
 - a mild spray and wipe cleaner/polisher
 - a mild spray and rinse cleaner/degreaser and water

- Avoid products that contain harsh detergents or chemical solvents that could damage the metal, paint, and plastic on your motorcycle.
- If your motorcycle is still warm from recent operation, give the engine and exhaust system time to cool off.
- Park in a shady area. Washing your motorcycle in bright sunlight may cause the finish to fade because water droplets intensify the sun's brightness. Spotting is also more likely because surface water can dry before you have time to wipe it off.
- Clean your motorcycle regularly to protect surface finishes.

(cont'd)

Appearance Care

- We recommend the use of a garden hose to wash your motorcycle. High pressure washers (like those at coin-operated car washes) can damage certain parts of your motorcycle.

NOTICE

High pressure water (or air) can damage certain parts of your motorcycle.

- After cleaning, inspect for damage, wear, and leaks (fuel, oil, coolant, and brake fluid).

Washing Your Motorcycle with a Mild Detergent

Refer to *Safety Precautions* on page 52 .

1. Rinse your motorcycle thoroughly with cool water to remove loose dirt.
2. Fill a bucket with cool water. Mix in a mild, neutral detergent, such as dish washing liquid or a product made especially for washing motorcycles or automobiles.
3. Wash your motorcycle with a sponge or a soft towel. As you wash, check for heavy grime. If necessary, use a mild cleaner/degreaser to remove the grime.

4. Clean the headlight and other plastic parts using a cloth or sponge dampened with a solution of mild detergent and water. When cleaning the plastic headlight lens, use more care because it will scratch easier than a glass lens. Rub any soiled area, gently rinsing it frequently with fresh water.

If the inside of the headlight lens appears clouded immediately after washing, it should clear after a few minutes of riding.

(cont'd)

Appearance Care

5. After washing, rinse your motorcycle thoroughly with plenty of clean water to remove any residue. Detergent residue can corrode alloy parts.
6. Dry your motorcycle with a chamois or a soft towel. Leaving water on the surface to air dry can cause dulling and water spots. As you dry, inspect for chips and scratches.
7. Lubricate the drive chain to prevent rusting.
8. Start the engine and let it idle for several minutes. The engine heat will help dry moist areas.
9. As a precaution, ride your motorcycle at a slow speed and apply the brakes several times. This will help dry the brakes and restore normal braking performance.

Clean the Matte Painted Surface

Refer to *Safety Precautions* on page 52 .

Use a soft cloth or sponge, plenty of water, and a mild detergent to clean the matte paint. Dry with a soft, clean cloth.

Do not use polishing compounds or wax containing polishing compounds. These can damage or discolor the paint.

To keep your Honda looking new, clean and polish it frequently.

Spray Cleaning Your Motorcycle

Refer to *Safety Precautions* on page 52 .

Avoid using spray cleaner products on the tires or suspension components.

Suggestions for using spray cleaner(s) follow:

Appearance Care

Motorcycle Condition	Recommended Cleaning
Dust and fingerprint smudges.	Apply a spray cleaner/polish and wipe the paint, chrome, glass, and clear plastic.
Light road grime.	Spray any difficult-to-reach or very dirty areas with a spray cleaner/degreaser. Rinse and dry. Apply a spray cleaner/polish and wipe with a non-abrasive cloth.
Heavy grime. Oil leaks. Brake dust.	Use a spray cleaner/degreaser. If necessary, rub with a sponge. Rinse and dry. Apply a spray cleaner/polish and wipe with a non-abrasive cloth.
Dull, corroded chrome or aluminum.	Apply a high quality chrome/aluminum polish and wipe with a non-abrasive cloth.

Painted Aluminum Wheel Maintenance

Refer to *Safety Precautions* on page 52 .

Aluminum may corrode from contact with dirt, mud, or road salt. Clean the wheels after riding through any of these substances. Use a wet sponge and mild detergent. Avoid stiff brushes, steel wool, or cleaners containing abrasives or chemical compounds.

After washing, rinse with plenty of water and dry with a clean cloth.

If the paint is chipped, apply touch-up paint.

Appearance Care

Finishing Touches

Refer to *Safety Precautions* on page 52 .

After washing your motorcycle, consider using a commercially-available spray cleaner/polish or quality liquid or paste wax to finish the job. Use only a non-abrasive polish or wax made specifically for motorcycles or automobiles. Apply the polish or wax according to the instructions on the container.

If a surface on your motorcycle is chipped or scratched, your Honda dealer has touch-up paint to match your motorcycle's color. Be sure to use your motorcycle's color code (page 166) when you buy touch-up paint.

If the frame has a chip that exposes the metal, first apply primer (to prevent corrosion) and then apply the touch-up paint. Several thin layers of touch-up paint are better than one thick coat.

Here's a few helpful tips on how to store and transport your Honda, and how to be an environmentally responsible motorcycle owner.

Storing Your Honda	130
Transporting Your Motorcycle	134
You & the Environment	135

Storing Your Honda

If you won't be riding for an extended period, such as during the winter, thoroughly inspect your motorcycle and correct any problem before storing it. That way, needed repairs won't be forgotten and it will be easier to get your motorcycle running again.

We suggest you perform the following procedures to keep your motorcycle in top condition. These storage procedures will reduce the deterioration that can occur during storage.

Preparation for Storage

Refer to *Safety Precautions* on page 52 .

This procedure requires a means for draining and disposing of drained fuel (page 135).

1. Change the engine oil (page 78).
2. Make sure the cooling system is filled with a 50/50% antifreeze solution (page 81).
3. Fill the fuel tank. Make sure the fuel fill cap is properly installed.

4. To prevent rusting in the cylinders, perform the following:
- Remove the spark plug cap from the spark plug. Using tape or string, secure the cap to any convenient plastic body part so that it is positioned away from the spark plug.
 - Remove the spark plug from the engine and store it in a safe place. Do not connect the spark plug to the spark plug cap.
 - Pour a tablespoon (15–20 cm³) of clean engine oil into the cylinder and cover the spark plug hole with a piece of cloth.
 - With the engine stop switch in the RUN position, press the start button several times to crank the engine and distribute the oil.

- Reinstall the spark plug and spark plug cap.

(cont'd)

Storing Your Honda

5. Remove the battery and charge it fully. Store it in an area protected from freezing temperatures and direct sunlight. Slow charge the battery (page 120) once a month.
6. Wash and dry your motorcycle. Wax all painted surfaces. Apply rust-inhibiting oil to the chrome pieces.
7. Lubricate the drive chain (page 114).
8. Inflate the tires to their recommended pressures (page 101).
9. Store your motorcycle in an unheated area, free of dampness, away from sunlight, with a minimum of daily temperature variation.
10. Place your motorcycle on blocks to lift both tires off the floor.
11. Cover your motorcycle with a porous material. Avoid using plastic or similar non-breathing, coated materials that restrict air flow and allow heat and moisture to accumulate.

Removal from Storage

Refer to *Safety Precautions* on page 52 .

1. Uncover and clean your motorcycle.
2. If your motorcycle has been stored for more than four months — change the engine oil (page 78).
3. If your motorcycle has been stored for more than two months — ask your Honda dealer to drain and replace the fuel.
4. Charge the battery (page 120) as required. Install the battery.
5. Lubricate the drive chain (page 114).
6. Perform a pre-ride inspection (page 25), then test-ride your motorcycle at low speeds.

Transporting Your Motorcycle

If your motorcycle needs to be transported, it should be carried on a motorcycle trailer, or a truck or trailer with a flatbed area. Do not tow your motorcycle, as towing can seriously damage the transmission.

When contacting a towing or transporting service, be sure to ask if they have a flatbed area, a loading ramp or power ramp to safely lift the motorcycle, and motorcycle tie-down straps.

Owning and riding a motorcycle can be enjoyable, but you must do your part to protect nature.

Following are tips on how you can be an environmentally-responsible motorcycle owner.

- **Choose Sensible Cleaners.** Use a biodegradable detergent when you wash your motorcycle. Avoid aerosol spray cleaners that contain chlorofluorocarbons (CFCs) which damage the atmosphere's protective ozone layer. Don't throw cleaning solvents away; see the following guidelines for proper disposal.

- **Recycle Wastes.** It's illegal and thoughtless to put used engine oil in the trash, down a drain, or on the ground. Used oil, gasoline, coolant, and cleaning solvents contain poisons that can hurt refuse workers and contaminate our drinking water, lakes, rivers, and oceans. Before changing your oil, make sure you have the proper containers. Put oil and other toxic wastes in separate sealed containers and take them to a recycling center. Call your local or state office of public works or environmental services to find a recycling center in your area, and to get instructions on how to dispose of non-recyclable wastes.

Taking Care of the Unexpected

This section discusses the more common problems that can occur with your motorcycle while you're riding. It tells you how to evaluate each problem and what actions you can take to try to resume riding. If the problem cannot be safely solved, this section also gives instructions on the proper way to have your motorcycle transported.

For information about transporting your motorcycle, see page 134 .

General Guidelines	138
If Your Engine Quits or Won't Start	139
If You Have a Flat Tire	144
If Your Engine Overheats	154
If a Fuse Blows.....	156
If You Crash	160
If You Lose Your Key	161
If Your Battery Is Low (or Dead)	162

Taking Care of the Unexpected

General Guidelines

Keeping your motorcycle well-maintained is the best way to reduce the possibility of having a problem on the road. However, since problems can arise even with well-maintained machines, you may consider subscribing to an emergency roadside service plan.

Remember to take along your owner's manual, the tool kit that came with your motorcycle, and any other items (such as tire repair supplies and additional tools) that might help you solve a problem on your own.

Should you ever have a problem while riding, please follow these guidelines:

- Always put personal safety first.
- Take time to assess the situation and your options before deciding what to do.
- If the problem is relatively minor and you have the tools, supplies, and skills to make a temporary repair, be sure to have permanent repairs made as soon as possible.
- Do not continue riding if you are hurt or your motorcycle is not in safe riding condition.

Additional recommendations for specific problems follow.

If Your Engine Quits or Won't Start

Proper operation and maintenance can prevent starting and engine performance problems. In many cases, the cause of the problem may be a simple operational oversight.

If you have a problem starting the engine — or experience poor engine performance — the following information may help you. If you can't correct the problem, see your Honda dealer.

If your motorcycle won't start, listen as you press the start button. If you don't hear the starter motor turning, refer to the *Starter motor doesn't operate* symptom. If you can hear the starter motor working normally, refer to the *Starter motor works, but the engine won't start* symptom.

If Your Engine Quits or Won't Start

SYMPTOM: Starter motor doesn't operate.	
POSSIBLE CAUSE	WHAT TO DO
ignition switch OFF	Turn the ignition switch ON.
transmission not in neutral	Shift into neutral.
side stand down (when transmission not in neutral)	Put the transmission in neutral or raise the side stand and pull the clutch lever in.
blown fuse	Replace with a new fuse of the same rating (page 156).
battery lead loose	Tighten the battery lead.
low (or dead) battery	Charge the battery (page 120). If charging doesn't help, see your Honda dealer.
faulty starter motor	If all possible causes are negative, the starter motor may be faulty. See your Honda dealer.

If Your Engine Quits or Won't Start

SYMPTOM: Starter motor works, but the engine won't start.	
POSSIBLE CAUSE	WHAT TO DO
engine stop switch OFF	Turn the engine stop switch to RUN.
out of fuel	Fill the fuel tank.
flooded engine	See <i>Flooded Engine</i> (page 35).
loose or unconnected spark plug cap	Install the spark plug cap securely. If the engine still won't start, see your Honda dealer.
loose battery cables	Tighten the battery terminal bolts.
weak battery	Charge the battery (page 120). If charging doesn't help, see your Honda dealer.

If Your Engine Quits or Won't Start

SYMPTOM: Engine starts, but stalls as you shift into gear.	
POSSIBLE CAUSE	WHAT TO DO
side stand down	Raise the side stand. Start again.

SYMPTOM: Engine starts, but runs poorly.	
POSSIBLE CAUSE	WHAT TO DO
idles roughly, too fast, stalls	See your Honda dealer.
overheating	Check the coolant temperature gauge. Refer to <i>If Your Engine Overheats</i> , page 154.
runs erratically, misfires	May damage catalytic converter. See your Honda dealer.
blubbers (rich fuel mixture)	See your Honda dealer.

If Your Engine Quits or Won't Start

SYMPTOM: Engine starts, but runs poorly (cont'd).	
POSSIBLE CAUSE	WHAT TO DO
sooty exhaust (rich fuel mixture)	See your Honda dealer.
detonates or pings under load	If applicable, switch to the recommended octane gasoline (page 70) or change your brand of gasoline. If the problem persists, see your Honda dealer.
afterfires (backfires)	May damage catalytic converter. See your Honda dealer.
pre-ignition (runs on after ignition switched OFF)	May damage catalytic converter. See your Honda dealer.

If You Have a Flat Tire

A flat tire is always unwelcome, especially if you are far from help. If you think you are losing air, or you hit a pothole or hard object, pull safely to the side of the road so you can inspect the tires and assess the situation. (Be sure to park on a firm, level surface and use the side stand for support.) You should examine the tire treads and sidewalls for foreign objects or damage. If you find a tire that has been punctured or damaged, you have two options.

Option 1:

Have Your Motorcycle Transported

If a tire has a major puncture or a cut in the tread or sidewall, or the bead has come loose from the rim, there is probably not much you can do except have your motorcycle transported to a Honda dealer

or other qualified service facility. Even with a simple puncture, this may be the safest and least troublesome solution. For transporting instructions, see page 134.

Option 2:

Make a Temporary Roadside Repair

If a tire has only a minor nail puncture and is not completely flat, you may be able to make an emergency repair that could allow you to continue riding to where you can get the tire replaced or permanently repaired.

If You Have a Flat Tire

⚠ WARNING

Riding your motorcycle with a temporary tire repair can be risky. If the temporary repair fails, you can crash and be seriously injured or killed.

If you must ride with a temporary tire repair, ride slowly and carefully and do not exceed 50 km/h (30 mph) until the tire is permanently repaired or replaced.

Due to the uncertainty of any temporary repair, you should ride slowly (not over 50 km/h, 30 mph) and carefully (preferably without a passenger or cargo) until the tire is replaced or permanently

repaired. Stop frequently and check the air pressure. If the tire is losing pressure, it may be unsafe to continue riding. As the tire gets low, it will affect the handling of your motorcycle (especially with a passenger and cargo), and it may overheat and blow out.

Types of Temporary Repairs

The following types of temporary repairs generally require a source of air to inflate the tire. Possible sources include CO₂ cartridges or cans of compressed air designed to inflate a tire.

If You Have a Flat Tire

- **Inflate the tire:** Tubeless tires have some self-sealing ability if they are punctured and the result is usually just a slow leak. If this is the case, you can try inflating the tire to see if it will hold air pressure. If you can see a nail or other object embedded in the tire tread, do not remove it at this time.
- **Plug the hole:** The idea here is to do something to temporarily stop the leak. If you have a tubeless tire repair kit, you can pull out the nail and try inserting an external plug in the puncture. Follow the instructions that came with the repair kit and be sure to inflate the tire to the correct pressure.

Should You Repair or Replace a Tire?

We strongly recommend that you replace, not permanently repair, any tire that is punctured or damaged, even if the tire has only a minor puncture. For a full discussion of repairs and replacement, see page 104 .

If You Have a Flat Tire

Emergency Front Wheel Removal/Installation

Refer to *Safety Precautions* on page 52 .

We recommend wheel removal be done only by your Honda dealer or another qualified mechanic. Do not attempt to remove the wheel on your own. Wheel removal requires mechanical skill and professional tools.

Removal

1. Park your motorcycle on a firm, level surface.
2. Raise the front wheel off the ground by placing a support block under the engine.

3. Remove the speedometer cable (1) by pushing the tab (2).
4. Remove the front axle nut (3).

LEFT FRONT

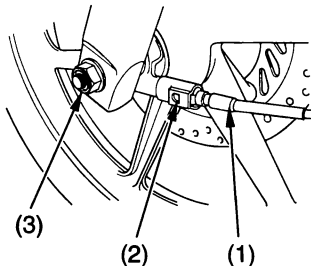

- (1) speedometer cable
- (2) tab
- (3) front axle nut

(cont'd)

If You Have a Flat Tire

5. Remove the front axle shaft (4), wheel, and side collar.

RIGHT FRONT

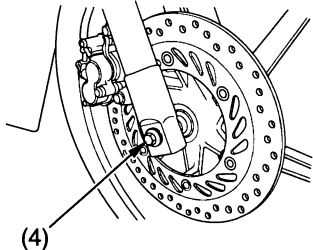

(4) front axle shaft

- Avoid getting grease, oil, or dirt on the disc or pad surfaces. Any contamination can cause poor brake performance or rapid pad wear after reassembly.

- Avoid depressing the brake lever when the wheel is off the motorcycle. This will force the caliper pistons out of the cylinders. The result will be loss of brake fluid. If this occurs, the brake system will require service. See your Honda dealer for this service.

If You Have a Flat Tire

Installation

1. Install the side collar and position the wheel between the fork legs. Insert the front axle shaft from the right side, through the right fork leg and wheel hub.
 - To avoid damaging the brake pads while installing the wheel, carefully fit the brake disc between the pads.
2. Position the lug (5) on the speedometer gearbox against the lug on the left fork leg.

LEFT FRONT

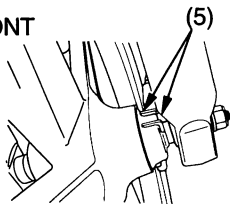

(5) lug

3. Tighten the front axle nut to the specified torque:
59 N·m (43 lbf·ft)
4. Operate the front brake and pump the fork several times. Check for free wheel rotation after the brake is released. Recheck the wheel if the brake drags or the wheel does not rotate freely.

If a torque wrench was not used for installation, see your Honda dealer as soon as possible to verify proper assembly. Improper assembly may lead to loss of braking capability.

5. Install the speedometer cable.

If You Have a Flat Tire

Emergency Rear Wheel Removal/Installation

Refer to *Safety Precautions* on page 52 .

We recommend wheel removal be done only by your Honda dealer or another qualified mechanic. Do not attempt to remove the wheel on your own. Wheel removal requires mechanical skill and professional tools.

Removal

1. Park your motorcycle on a firm, level surface.
2. Raise the rear wheel off the ground by placing a support block under the engine.

3. Loosen the rear axle nut (1).
4. Loosen the drive chain lock nuts (2) and drive chain adjusting nuts (3) on both sides of the swingarm.

LEFT REAR

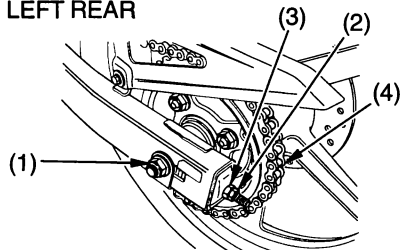

- | | |
|-------------------|-------------------|
| (1) rear axle nut | (3) adjusting nut |
| (2) lock nut | (4) drive chain |

5. Remove the rear axle nut.
6. Remove the drive chain (4) from the rear wheel sprocket by pushing the rear wheel forward.

If You Have a Flat Tire

RIGHT REAR

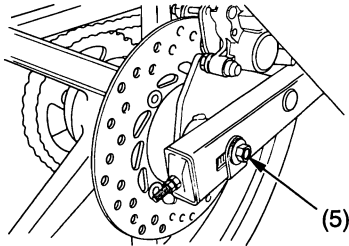

(5) rear axle shaft

7. Remove the rear axle shaft (5), rear wheel, side collars and rear brake bracket from the swingarm.

- To avoid damage to the brake hose during removal, support the caliper assembly so that it doesn't hang from the hose. Do not twist the brake hose.
- Avoid depressing the brake pedal when the wheel is off the motorcycle. This will force the caliper pistons out of the cylinders. The result will be a loss of brake fluid. If this occurs, the brake system will require service. See your Honda dealer for this service.

(cont'd)

If You Have a Flat Tire

Installation

1. Install the side collars and position the wheel and rear brake bracket.
 - While installing the wheel, carefully fit the brake disc between the brake pads to avoid damaging the pads.
 - Avoid getting grease, oil, or dirt on the disc or pad surfaces. Any contamination can cause poor brake performance or rapid pad wear after reassembly.
2. Make sure that the lug (1) on the swingarm (2) is located in the slot (3) on the rear brake bracket (4).

3. Install the rear axle shaft.

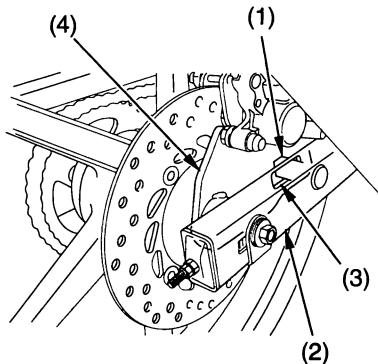

- | | |
|--------------|------------------------|
| (1) lug | (3) slot |
| (2) swingarm | (4) rear brake bracket |

If You Have a Flat Tire

4. Install the drive chain by pushing the rear wheel forward.
5. Install the rear axle nut and tighten the drive chain adjusting bolts.
Refer to drive chain adjustment (page 112).
6. Tighten the rear axle nut to the specified torque:
59 N·m (43 lbf·ft)
Failure to provide adequate disc-to-rear brake bracket clearance may damage the brake discs and impair braking efficiency.
7. After installing the wheel, apply the brakes several times, then recheck both discs for caliper holder to disc clearance. Do not operate the motorcycle without adequate clearance.

If a torque wrench was not used for installation, see your Honda dealer as soon as possible to verify proper assembly. Improper assembly may lead to loss of braking capability.

If Your Engine Overheats

Normally, the needle on your temperature gauge will rise to a point about midway between C (cold) and H (hot) and then level off. Hot weather may cause the needle to rise higher than normal. So will temporary stress such as climbing a hill. If you're stuck in stop-and-go traffic, the needle may climb some, but the radiator fan is designed to prevent overheating. Be aware of these variations as you monitor the gauge.

If the needle moves toward H for no apparent reason, pull safely to the side of the road. If possible, park in a shady area.

NOTICE

Continuing to ride with an overheated engine can cause serious engine damage.

- A steaming engine indicates a coolant leak. Shut the engine off and wait until the steaming stops. Look for a leak, but don't touch the engine or radiator system. Let everything cool off first.
- If there's no obvious problem, leave the engine on so the fan and coolant circulating system can continue working. Monitor the temperature gauge. The needle may drop to the normal range after a brief stop with no load on the engine.

If Your Engine Overheats

- Check the radiator fan.
If the fan is not working, turn the engine off. Open the fuse box (page 156) and check the radiator fan fuse. If the fuse is blown, replace it with the proper (same rating) spare fuse. Start the engine. If the needle climbs to the red zone and stays there, turn the engine off.
If the radiator fan is working, visually check the coolant level in the reserve tank, located behind the frame (page 81). It isn't necessary to touch the radiator system.
- If the reserve tank is low or empty, don't ride without adding coolant (page 81). After adding coolant, turn the engine on and check the temperature gauge. If the needle doesn't drop, do not ride. The engine needs repair. Transport your

motorcycle to a Honda dealer (page 134).

If the temperature drops to normal, check the coolant level. If it has gone down, add more coolant.

If you are able to resume riding, continue to monitor the gauge frequently.

If there's a mild leak, you can ride for awhile, carefully watching the gauge. Be prepared to stop and add more coolant or water. If the leak is bad, transport your motorcycle to a Honda dealer (page 134).

If a Fuse Blows

All of the electrical circuits on your motorcycle have fuses to protect them from damage caused by excess current flow (short circuit or overload).

If something electrical on your motorcycle stops working, the first thing you should check for is a blown fuse.

Determine from the chart on the circuit fuse box cover which fuse or fuses control that component. Check those fuses first, but check all the fuses before looking elsewhere for another possible cause of the problem. Replace any blown fuses and check component operation.

- Main fuse is located on the starter motor magnetic switch (1) under the front seat.
- FI fuse is located under the front seat.
- The circuit fuse boxes are located behind the battery cover under the front seat.

Recommended Fuses

main fuse	30A
FI fuse	10A
other fuses	10A

1. To prevent an accidental short circuit, turn the ignition switch OFF before checking or replacing the fuses.

If a Fuse Blows

UNDER FRONT SEAT

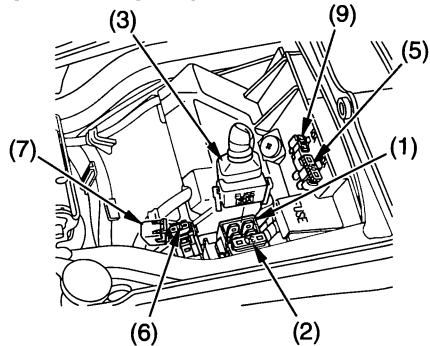

- (1) starter motor magnetic switch
- (2) main fuse
- (3) wire connector
- (5) spare main fuse
- (6) FI fuse
- (7) FI fuse cover
- (8) FI fuse
- (9) spare FI fuse

Main Fuse Access:

2. Remove the front seat (page 69).
3. Lift the starter motor magnetic switch (1) slightly.
4. To access the main fuse (2), disconnect the wire connector (3) of the starter motor magnetic switch.
5. Pull the main fuse out. If it is blown (4), install the spare main fuse (5).

MAIN FUSE

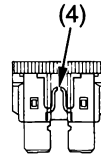

- (4) blown fuse

6. Reconnect the wire connector.

(cont'd)

If a Fuse Blows

FI Fuse Access:

7. To access FI fuse (6), open the FI fuse cover (7).

8. Pull FI fuse out.

If it is blown (8), install spare FI fuse (9).

FI FUSE

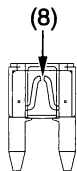

(8) blown fuse

9. Close the FI fuse cover.

Circuit Fuse Access:

10. Open the battery cover (page 118).

11. Open the fuse box cover (10).

UNDER FRONT SEAT

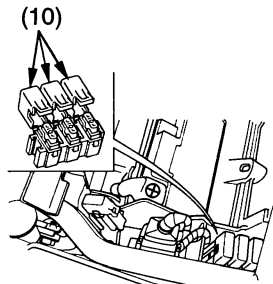

(10) fuse box cover

12. To check or replace a circuit fuse, pull the old fuse out. Look for a burned wire inside the fuse. If the fuse is blown (11), replace it with a spare fuse of the same rating.

If a Fuse Blows

If you do not have a replacement fuse with the proper rating for the circuit, install one with a lower rating.

NOTICE

Replacing a fuse with one that has a higher rating greatly increases the chance of damage to the electrical system.

CIRCUIT FUSE

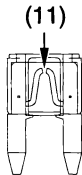

(11) blown fuse

13. Close the fuse box cover and battery cover.
14. Install the front seat.

If you do not have a spare fuse and you cannot ride the motorcycle without fixing the problem, take a fuse of the same rating or a lower rating from one of the other circuits that you can do without temporarily.

If you replace a blown fuse with a spare fuse that has a lower rating, replace the fuse with the correct rating as soon as you can. Also remember to replace any spare fuses that were installed.

If the replacement fuse of the same rating burns out in a short time, there is probably a serious electrical problem on your motorcycle. Leave the blown fuse in that circuit and have your motorcycle checked by your Honda dealer.

If You Crash

Personal safety is your first priority after any accident. If you or anyone else has been injured, take time to assess the severity of the injuries and whether it is safe to continue riding. Call for emergency assistance if needed. Also follow applicable laws and regulations if another person or vehicle is involved in the accident.

If you decide you are capable of riding safely, carefully inspect your motorcycle for damage and determine if it is safe to ride. Check the tightness of critical nuts and bolts securing such parts as the handlebar, control levers, brakes, and wheels.

If there is minor damage, or you are unsure about possible damage, ride slowly and cautiously. Sometimes, crash damage is hidden or not immediately apparent, so you should have your motorcycle thoroughly checked at a qualified service facility as soon as possible. Also, be sure to have your Honda dealer check the frame and suspension after any serious crash.

If your motorcycle cannot be ridden, see *Transporting Your Motorcycle*, page 134.

If You Lose Your Key

Be sure to record your key number in the Quick Reference section at the rear of the manual. You'll need this number to have a duplicate key made.

A lost key won't be a problem if you take preventative action. Store one duplicate key in a safe place at home and carry a second duplicate in your wallet.

If you lose your key and aren't carrying a duplicate, either get your spare or have one made. If you don't know your key number, call the dealer where you purchased your Honda motorcycle. They may have it listed in their records. If they don't, transport your motorcycle to them or the nearest Honda dealer. The dealer will probably have to remove the ignition switch assembly to find the key number so they can make a key for you.

If Your Battery Is Low (or Dead)

Jump starting is not recommended, especially if you use an automobile battery. The greater amperage of an automobile battery when the car engine is running can damage your motorcycle's electrical system.

Bump starting is also not recommended.

If you can't charge the battery or it appears unable to hold a charge, contact your Honda dealer.

Technical Information

This section contains dimensions, capacities, and other technical data, plus information on government requirements and how to break-in your motorcycle.

Vehicle Identification.....	164
Specifications	167
Break-in Guidelines.....	174
Emission Control Systems	175
Catalytic Converter	181
Oxygenated Fuels	182

Vehicle Identification

Serial Numbers

The VIN and engine serial number are required when you register your motorcycle. They may also be required when ordering replacement parts. You may record these numbers in the Quick Reference section at the rear of this manual.

The VIN (vehicle identification number) is stamped on the right side of the steering head and also appears on the Safety Certification Label attached to the right side of the frame.

RIGHT SIDE

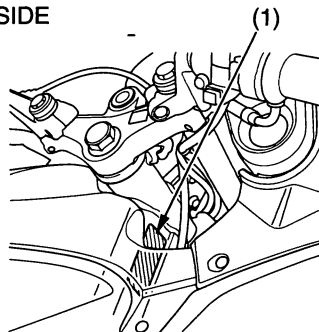

(1) VIN

Vehicle Identification

RIGHT SIDE

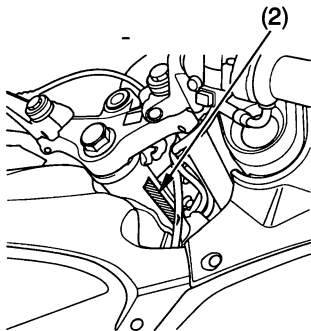

(2) VIN

The engine number (3) is stamped on the left side of the crankcase.

LEFT SIDE

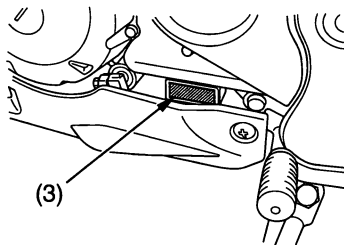

(3) engine number

Vehicle Identification

Color Label & Code

The color label is attached to left side of the steering head.

The color code is helpful when ordering replacement parts. You may record the color and code in the Quick Reference section at the rear of this manual.

LEFT SIDE

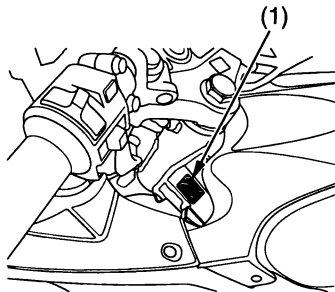

(1) color label

Specifications

Dimensions	
overall length	1,920 mm (75.6 in)
overall width	680 mm (26.8 in)
overall height	1,065 mm (41.9 in)
wheelbase	1,295 mm (51.0 in)
ground clearance	175 mm (6.9 in)

Specifications

Fuel & Lubricants	
fuel recommendation	unleaded gasoline, pump octane number of 86 or higher
fuel tank capacity	10,0 ℓ (2,64 US gal) including reserve
engine oil capacity	after disassembly: 1,3 ℓ (1,4 US qt) after draining: 1,0 ℓ (1,1 US qt)
engine oil recommendation	API Service Classification SG or higher except oils labeled as energy conserving on the circular API service label, SAE 10W-30, JASO T 903 standard MA, Pro Honda GN4 4-stroke oil or Honda 4-stroke oil, or an equivalent motorcycle oil
drive chain lubricant	SAE 80 or 90 gear oil
cooling system, recommendation	Pro Honda HP Coolant or an equivalent high quality ethylene glycol antifreeze containing corrosion protection inhibitors specifically recommended for use in aluminum engines
cooling system, capacity	0,98 ℓ (1,04 US qt)

Specifications

Capacities	
passenger capacity	operator and one passenger
maximum weight capacity	170 kg (375 lbs) rider, passenger, all cargo and accessories

Engine Specifications	
displacement	125 cm ³ (7.6 cu-in)
bore & stroke	58.0 × 47.2 mm (2.28 × 1.86 in)
compression ratio	11.0 : 1
spark plug (standard)	CR8E (NGK) or U24ESR-N (DENSO)
spark plug (high speed riding)	CR9E (NGK) or U27ESR-N (DENSO)
spark plug gap	0.70 – 0.80 mm (0.028 – 0.031 in)
valve clearance (cold)	intake 0.06 mm (0.002 in) exhaust 0.27 mm (0.011 in)
idle speed	1,450 ± 100 rpm

Specifications

Power Transmission	
primary reduction	3.350
gear ratio, 1st	3.455
2nd	1.941
3rd	1.450
4th	1.174
5th	1.041
6th	0.923
final reduction	2.800
standard sprocket sizes	drive (engine) sprocket: 15 teeth driven (rear wheel) sprocket: 42 teeth
final drive	chain DID428VI3-124LE

Specifications

Chassis & Suspension	
caster	25°06'
trail	88.8 mm (3.50 in)
tire size, front	80/90-17M/C 44P IRC NR73s
tire size, rear	100/80-17M/C 52P IRC NR73s
tire type	bias-ply, tubeless
tire pressure, front (cold)	200 kPa (29 psi)
tire pressure, rear (cold)	225 kPa (33 psi)

Specifications

Electrical	
battery	12V – 6 Ah
generator	0.290 kW/5,000 rpm

Lights	
headlight	12V – 55W
brake/tail light	12V – 21/5W
turn signal lights	12V – 23W (front) 12V – 23W (rear)
instrument lights	12V – 1.7W
neutral indicator	12V – 1.7W
turn signal indicator	12V – 1.7W
high beam indicator	12V – 1.7W
license light	12V – 5W
position light	12V – 5W

Fuses	
main	30A
other fuses	10A

Specifications

Torque Specifications	
engine oil drain bolt	25 N·m (18 lbf·ft)
front wheel axle nut	59 N·m (43 lbf·ft)
rear wheel axle nut	59 N·m (43 lbf·ft)

Break-in Guidelines

Help assure your motorcycle's future reliability and performance by paying extra attention to how you ride during the first 500 km (300 miles).

During this period, avoid full-throttle starts and rapid acceleration.

Emission Control Systems

Exhaust Emission Requirements

The U.S. Environmental Protection Agency (EPA), the California Air Resources Board (CARB), and Environment Canada require that your motorcycle comply with applicable exhaust emissions standards during its useful life, when operated and maintained according to the instructions provided.

Warranty Compliance

Compliance with the terms of the Distributor's Warranties for Honda Motorcycle Emission Control Systems is necessary in order to keep the emissions system warranty in effect.

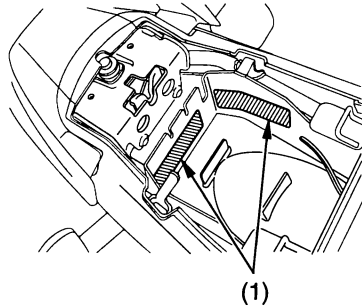

(1) vehicle emission control information label

Emission Control Systems

Source of Exhaust Emissions

The combustion process produces carbon monoxide (CO), oxides of nitrogen (NO_x), and hydrocarbons (HC). Control of hydrocarbons and oxides of nitrogen is very important because, under certain conditions, they react to form photochemical smog when subjected to sunlight. Carbon monoxide does not react in the same way, but it is toxic.

Honda Motor Co., Ltd. utilizes various systems to reduce hydrocarbons, oxides of nitrogen, and carbon monoxide.

Exhaust Emission Control System

The exhaust emission control system consists of a PGM-FI system and a three-way catalytic converter.

No adjustment to these systems should be made although periodic inspection of the components is recommended.

PGM-FI System

The PGM-FI system uses sequential multiport fuel injection. It has four subsystems: Air Intake, Engine Control, Fuel Control, and Exhaust Control. The Engine Control Module (ECM) uses various sensors to determine how much air is going into the engine. It then controls how much fuel to inject under all operating conditions.

Ignition Timing Control System

The system constantly adjusts the ignition timing, reducing the amount of HC, CO and NOx produced.

Emission Control Systems

Three-Way Catalytic Converter

The three-way catalytic converter is in the exhaust system. Through chemical reactions, they convert HC, CO, and NOx in the engine's exhaust to carbon dioxide (CO₂), dinitrogen (N₂), and water vapor.

Crankcase Emission Control System

The engine is equipped with a closed crankcase system to prevent discharging crankcase emissions into the atmosphere. Blow-by gas is returned to the combustion chamber through the air cleaner and the intake manifold.

Problems That May Affect Motorcycle Exhaust Emissions

If you are aware of any of the following symptoms, have the vehicle inspected and repaired by your authorized Honda motorcycle dealer.

Symptoms:

1. Hard starting or stalling after starting
2. Rough idle
3. Misfiring or backfiring during acceleration
4. After-burning (backfiring)
5. Poor performance (driveability) and poor fuel economy

Emission Control Systems

Noise Emission Control System TAMPERING WITH THE NOISE CONTROL SYSTEM IS PROHIBITED:

U. S. federal law prohibits, or Canadian provincial laws may prohibit the following acts or the causing thereof: (1) The removal or rendering inoperative by any person, other than for purposes of maintenance, repair or replacement, of any device or element of design incorporated into any new vehicle for the purpose of noise control prior to its sale or delivery to the ultimate purchaser or while it is in use; or (2) the use of the vehicle after such device or element of design has been removed or rendered inoperative by any person.

AMONG THOSE ACTS PRESUMED TO CONSTITUTE TAMPERING ARE THE FOLLOWING ACTS:

1. Removal of, or puncturing the muffler, baffles, header pipes or any other component which conducts exhaust gases.
2. Removal of, or puncturing of any part of the intake system.
3. Lack of proper maintenance.
4. Replacing any moving parts of the vehicle, or parts of the exhaust or intake system, with parts other than those specified by the manufacturer.

Catalytic Converter

This motorcycle is equipped with a three-way catalytic converter.

The catalytic converter contains precious metals that serve as catalysts, promoting chemical reactions to convert the exhaust gasses without affecting the metals.

The catalytic converter acts on HC, CO, and NOx. A replacement unit must be an original Honda part or its equivalent.

The catalytic converter must operate at a high temperature for the chemical reactions to take place. It can set fire to any combustible materials that come near it. Park your motorcycle away from high grasses, dry leaves, or other flammables.

A defective catalytic converter contributes to air pollution, and can impair your engine's performance. Follow these guidelines to protect your motorcycle's catalytic converter.

- Always use unleaded gasoline. Even a small amount of leaded gasoline can contaminate the catalyst metals, making the catalytic converter ineffective.
- Keep the engine tuned-up.
- An engine that is misfiring may overheat the catalytic converter, causing damage to the converter or motorcycle. Have your motorcycle diagnosed and repaired if it is misfiring, backfiring, stalling or otherwise not running properly.

Oxygenated Fuels

Some conventional gasolines are being blended with alcohol or an ether compound. These gasolines are collectively referred to as oxygenated fuels. To meet clean air standards, some areas of the United States and Canada use oxygenated fuels to help reduce emissions. If you use an oxygenated fuel, be sure it is unleaded and meets the minimum octane rating requirement.

Before using an oxygenated fuel, try to confirm the fuel's contents. Some states/provinces require this information to be posted on the pump.

The following are the EPA-approved percentages of oxygenates:

ETHANOL (ethyl or grain alcohol) 10%
by Volume

You may use gasoline containing up to 10% ethanol by volume. Gasoline containing ethanol may be marketed under the name "Gasohol".

MTBE (Methyl Tertiary Butyl Ether) 15%
by Volume

You may use gasoline containing up to 15% MTBE by volume.

METHANOL (methyl or wood alcohol) 5% by Volume

You may use gasoline containing methanol containing up to 5% methanol by volume as long as it also contains cosolvents and corrosion inhibitors to protect the fuel system. Gasoline containing more than 5% methanol by volume may cause starting and/or performance problems. It may also damage metal, rubber, and plastic parts of your fuel system.

If you notice any undesirable operating symptoms, try another service station or switch to another brand of gasoline.

Fuel system damage or performance problems resulting from the use of an oxygenated fuel containing more than the percentages of oxygenates mentioned above are not covered under warranty.

Oxygenated fuels can damage paint and plastic. Be careful not to spill fuel when filling the fuel tank. Wipe up any spills immediately.

NOTICE

Oxygenated fuels can damage paint and plastic. Damage caused by spilled fuel is not covered by warranty.

Consumer Information

This section contains information on your warranty and how to get an official Honda Service Manual.

Authorized Manuals	186
Warranty Coverage	187
Warranty Service	188
Contacting Honda.....	189
Your Honda Dealer	190

Authorized Manuals

See your Honda dealer to order authorized manuals.

Also available but not necessary to service your model is the Honda Common Service Manual which explains theory of operation and basic service information for various systems common to all Honda motorcycles, motor scooters and ATVs.

These Honda manuals are written for the professional technician, but most mechanically-capable owners should find them easy to use if they have the proper tools and observe proper safety standards. Special Honda tools are necessary for some procedures.

Publication Item No.	Description
62KTY00	2007 CBR125RW Service Manual
61CM002	Common Service Manual
31KTYB00	2007 CBR125RW Owner's Manual

Warranty Coverage

Your new Honda is covered by these warranties:

- Motorcycle Limited Warranty
- Exhaust Emission Warranty
- Noise Control Warranty

There are responsibilities, restrictions, and exclusions which apply to these warranties. Please read the Warranties Booklet given to you by your Honda dealer at the time of purchase.

It is important to realize that your warranty applies to defects in material or workmanship of your Honda. Your warranty coverage does not apply to normal wear or deterioration associated with using the motorcycle.

Your warranty coverage will not be voided if you choose to perform your own maintenance. However, you should have the proper tools and service information and be mechanically qualified. Failures that occur due directly to improper maintenance are not covered.

Almost all of your warranty coverage can be extended through the Honda Plus Protection Plan. For more information, see your Honda dealer.

Warranty Service

Please remember that recommended maintenance interval servicing is not included in your warranty coverage. Additionally, your warranty does not apply to the normal wear of items (such as brakes, tires, etc.).

If you believe you have a problem with your motorcycle, call the service department of your Honda dealer. Make an appointment for an inspection and diagnosis. Remember, as the owner of the motorcycle, you will be asked to authorize that inspection. Your dealer will give you the results of the inspection. If the problem is covered under warranty, your dealer will perform the warranty repairs for you.

If you have questions about warranty coverage or the nature of the repair, it is best to talk to the service manager of your Honda dealer.

Sometimes, in spite of the best intentions of all concerned, a misunderstanding may occur. If you aren't satisfied with your dealer's handling of the situation, we suggest you discuss your problem with the appropriate member of the dealership's management team. If the problem has already been reviewed with the Service Manager, Parts Manager, Sales Manager, etc., contact the Owner of the dealership or their designated representative.

Your owner's manual was written to cover most of the questions you might ask about your Honda. Any questions not answered in the owner's manual can be answered by your Honda dealer. If your dealer doesn't have the answer right away, they will get it for you.

If you have a difference of opinion with your dealer, please remember that each dealership is independently owned and operated. That's why it's important to work to resolve any differences at the dealership level.

Refer to the Warranties Booklet that was supplied with your vehicle.

Please include the following information in your letter:

- name, address, and telephone number
- product model, year, and VIN
- date of purchase
- dealer name and address

We will likely ask your Honda dealer to respond, or possibly acknowledge your comments directly.

Your Honda Dealer

Once you purchase your new Honda, get familiar with the organization of your Honda dealer so you can utilize the full range of services available.

The service department is there to perform regular maintenance and unexpected repairs. It has the latest available service information from Honda. The service department will also handle warranty inspections and repairs.

The parts department offers Genuine Honda parts, Pro Honda products, Hondaline accessories, and Honda accessories and products. The same quality that went into your Honda can be found in Genuine Honda replacement parts. You'll also find comparable quality in the accessories and products available

from the parts department.

The sales department offers the Honda Plus Protection Plan to extend almost all of your warranty coverage.

Your Honda dealer can inform you about competition and other riding events in your area.

We're sure you'll be as pleased with the service your Honda dealer continues to provide after the sale as you are with the quality and dependability of your Honda.

Table of Contents

The following presents the contents of each section of your owner's manual.

MOTORCYCLE SAFETY	1
Important Safety Information	2
Accessories & Modifications	5
Safety Labels	7
INSTRUMENTS & CONTROLS	9
Operation Component Locations	10
Gauges & Indicators	13
Controls & Features.....	17
Ignition Switch	17
Start Button.....	18
Engine Stop Switch	18
Headlight Dimmer Switch	19
Turn Signal Switch.....	19
Horn Button	20

BEFORE RIDING.....	21
Are You Ready to Ride ?	22
Protective Apparel.....	22
Rider Training	24
Is Your Motorcycle Ready to Ride ?	25
Pre-ride Inspection	25
Load Limits & Guidelines.....	28
Loading	28
Load Limits	29
Loading Guidelines	29

Table of Contents

BASIC OPERATION & RIDING.....	31
Safe Riding Precautions	32
Starting & Stopping the Engine	33
Preparation.....	33
Starting Procedure	34
Flooded Engine.....	35
Bank Angle Sensor Ignition Cut-off System.....	35
How to Stop the Engine	36
Shifting Gears.....	37
Braking	39
Parking.....	41
Theft-Prevention Tips	44
Riding with a Passenger or Cargo.....	45

SERVICING YOUR HONDA	47
<i>Before You Service Your Honda</i>	
The Importance of Maintenance	50
Maintenance Safety	51
Important Safety Precautions.....	52
Periodic Maintenance	54
Maintenance Schedule	56
Maintenance Record.....	61
<i>Service Preparations</i>	
Maintenance Component Locations	63
Tool Kit.....	66
Owner's Manual Storage.....	67
Seat Removal.....	68

(cont'd)

Table of Contents

SERVICING YOUR HONDA (cont'd)

Service Procedures

Fluids & Filters

Fuel	70
Engine Oil.....	73
Coolant.....	81
Crankcase Breather.....	85

Engine

Throttle	86
Clutch System.....	87
Spark Plug.....	91

Chassis

Brakes	95
Tires	101
Side Stand	108
Drive Chain.....	109

Electrical

Battery.....	116
--------------	-----

Appearance Care	121
-----------------------	-----

TIPS..... 129

Storing Your Honda	130
Transporting Your Motorcycle	134
You & the Environment	135

Table of Contents

TAKING CARE OF THE UNEXPECTED	137
General Guidelines	138
If Your Engine Quits or Won't Start ...	139
If You Have a Flat Tire	144
If Your Engine Overheats	154
If a Fuse Blows.....	156
If You Crash	160
If You Lose Your Key	161
If Your Battery Is Low (or Dead)	162
TECHNICAL INFORMATION	163
Vehicle Identification.....	164
Specifications	167
Break-in Guidelines.....	174
Emission Control Systems	175
Catalytic Converter	181
Oxygenated Fuels.....	182

CONSUMER INFORMATION	185
Authorized Manuals	186
Warranty Coverage	187
Warranty Service.....	188
Contacting Honda.....	189
Your Honda Dealer	190
TABLE OF CONTENTS	192
INDEX	196

QUICK REFERENCE

Index

A

accessories	5
air pressure, tires.....	101
apparel, protective	22
appearance care	121

B

bank angle sensor	35
battery	116
brakes,	
fluid.....	96
pad wear.....	99
braking	39
break-in guidelines	174

C

capacity, fuel	71
care, appearance	121
chain, drive	109
cleaning, appearance care	121
cleaning, matte color painted surface ..	125
clutch system	86
color label	166
compartment,	
owner's manual	67
tool kit.....	66
contacting Honda.....	189
consumer information	185
coolant.....	81
coolant temperature gauge	16
customer service	189

D

drive chain 109

E

emission control systems..... 175

engine,

 flooded..... 35

 number 164

 oil 73

 overheats..... 154

 pinging 70

 starting 33

 stop switch 18

 stopping..... 36

 won't start..... 139

environment..... 135

F

flat tire..... 144

flooded engine 35

fuel,

 oxygenated..... 182

 recommendation 70

 tank capacity 71

fuses 156

Index

G

gap, spark plug.....	93
gasohol.....	182
gasoline.....	70
gauges & indicators.....	13

H

headlight dimmer switch.....	19
helmet holder.....	43
high beam indicator.....	15
Honda,	
contacting.....	189
dealer.....	190
Honda service manual.....	186
horn button.....	20

I

identification, vehicle.....	164
ignition cutoff system,	
bank angle.....	35
side stand.....	108
ignition switch.....	17
indicators.....	13
inspection, pre-ride.....	25

K

key, lost.....	161
kit, tool.....	66

L

labels, safety	7
lamp check	14
limit, weight	29
load limits	29
loading guidelines.....	29
lock, steering.....	42

M

maintenance,	
component locations.....	63
importance	50
periodic	54
record	61
safety.....	51
schedule	56
manual, service	186
matte color painted surface, clean	125
maximum weight limit	29
modifications	6

N

numbers, serial.....	164
----------------------	-----

Index

O

odometer	15
oil, engine	73
operating controls	17
operation component locations	10
overheat, engine.....	154
owner's manual storage.....	67
oxygenated fuels.....	182

P

parking	41
pinging, engine	70
plug, spark.....	91
pre-ride inspection.....	25
problems, unexpected.....	137
protective apparel	22

R

removal, seat.....	68
rider training	3, 24
riding,	
basic operation.....	31
clothing	22
precautions.....	32
safety.....	2
safety precautions.....	32
with passenger or cargo.....	45

S

- safety,
 - important precautions 52
 - labels 7
 - riding precautions 32
- schedule, maintenance 56
- seat removal 68
- sensor, bank angle 35
- serial numbers 164
- service,
 - customer 189
 - manuals 186
 - warranty 188
- shifting gears 37
- side stand 108
- side stand ignition cutoff system 33
- spark knock 70
- spark plug 91
- specifications 167
- speedometer 15
- stand, side 108
- start button 18
- starting,
 - engine 33
 - troubleshooting 139
- steering lock 42
- stop switch, engine 18
- stopping engine 36
- storage,
 - motorcycle 130
 - owner's manual 67
- switch,
 - engine stop 18
 - headlight dimmer 19
 - ignition 17
 - turn signal 19

Index

T

tachometer	15
temperature gauge, coolant	16
theft prevention tips.....	44
throttle	86
tires,	
air pressure.....	101
flat.....	144
replacing	105
tool kit	66
training, rider	3, 24
transporting your motorcycle	134
trouble, unexpected	137
troubleshooting, starting.....	139
turn signal indicators	15

V

vehicle identification no. (VIN).....	164
---------------------------------------	-----

W

warranty,	
coverage.....	187
extended.....	187
service	188
washing your motorcycle	121
weight limit.....	29
wheels,	
front removal	147
rear removal.....	150

The following is a brief, but important collection of information you need to know about your Honda. You'll also find space to record important notes.

How To Avoid Costly Repairs

The engine of your Honda can be the most expensive component to repair. Proper maintenance, especially the use of the recommended fluids and filters, prevents premature wear and damage.

Frequent causes of costly repairs are:

- Engine oil: insufficient quantity, improper oil.
- Air cleaner: dirty, leaking because of improper installation (poor seal).

Record important information on the following page:

Quick Reference

VIN	
Engine No.	
Ignition Key No.	
Color Label	
Owner's Name	
Address	
City/Province	
Phone	
Dealer's Name	
Address	
City/Province	
Phone	
Service Mgr.	

Quick Reference

Quick Reference

Scheduled Maintenance	Initial: 1,000 km (600 miles) Regular: every 6,400 km (4,000 miles)
Pre-ride Inspection	Check the following items each time before you ride (page 25): tires & wheels, chain, leaks, loose parts, lights, throttle, brakes, indicators.
Periodic Checks	Check the following items monthly (page 55): tires & wheels, fluids, lights, freeplay, drive chain, fuses, nuts & bolts.
Fuel/Capacity	unleaded gasoline, pump octane number 86 or higher 10,0 l (2,64 US gal)
Engine Oil	API Service Classification SG or higher except oils labeled as energy conserving on the circular API service label, SAE 10W-30, JASO T 903 standard MA, Pro Honda GN4 4-stroke oil or equivalent
Coolant	ethylene glycol antifreeze (silicate-free) for aluminum engines in 50/50 solution with Pro Honda HP Coolant or an equivalent distilled water
Maximum Weight Capacity	170 kg (375 lbs) rider, passenger, all cargo and accessories

Quick Reference

Tires	Front : 80/90-17M/C 44P IRC NR73s Rear : 100/80-17M/C 52P IRC NR73s Type : bias-ply, tubeless
Tire Pressure (cold)	Front : 200 kPa (29 psi) Rear : 225 kPa (33 psi)
Spark Plugs	standard : CR8E (NGK) or U24ESR-N (DENSO) high speed riding : CR9E (NGK) or U27ESR-N (DENSO)
Fuses	main : 30A other : 10A

HONDA

The Power of Dreams



31KTYB00
00X31-KTY-B000

© P (HC) 8000.2007.03.7
PRINTED IN THAILAND