

# SHOP MANUAL

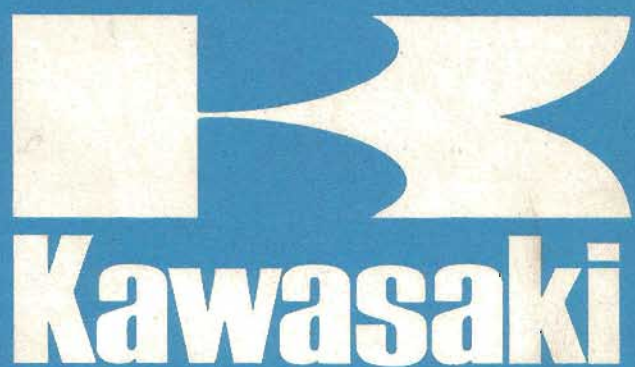

## KZ Series

1974

### Decimal Equivalents

INCH				MM INCH	INCH				MM INCH
$\frac{1}{64}$					$\frac{33}{64}$				
	$\frac{1}{32}$			1mm=		$\frac{17}{32}$			•
$\frac{3}{64}$				.03937 inch	$\frac{35}{64}$				14mm=
		$\frac{1}{16}$				$\frac{9}{16}$			.55118 inch
$\frac{5}{64}$				2mm=	$\frac{37}{64}$				15mm=
	$\frac{3}{32}$			.07874 inch		$\frac{19}{32}$			.59055 inch
$\frac{7}{64}$				3mm=	$\frac{39}{64}$				
		$\frac{1}{8}$		.11811 inch			$\frac{5}{8}$		16mm=
$\frac{9}{64}$					$\frac{41}{64}$				.62992 inch
	$\frac{5}{32}$			4mm=		$\frac{21}{32}$			17mm=
$\frac{11}{64}$				.15748 inch	$\frac{43}{64}$				.66929 inch
		$\frac{3}{16}$		5mm=			$\frac{11}{16}$		
$\frac{13}{64}$				.19685 inch	$\frac{45}{64}$				18mm=
	$\frac{7}{32}$					$\frac{23}{32}$			.70866 inch
$\frac{15}{64}$				6mm=	$\frac{47}{64}$				19mm=
		$\frac{1}{4}$		.23622 inch			$\frac{3}{4}$		.74803 inch
$\frac{17}{64}$				7mm=	$\frac{49}{64}$				
	$\frac{9}{32}$			.27559 inch		$\frac{25}{32}$			20mm=
$\frac{19}{64}$					$\frac{51}{64}$				.78740 inch
		$\frac{5}{16}$		8mm=			$\frac{13}{16}$		21mm=
$\frac{21}{64}$				.31496 inch	$\frac{53}{64}$				.82677 inch
	$\frac{11}{32}$			9mm=		$\frac{27}{32}$			
$\frac{23}{64}$				.35433 inch	$\frac{55}{64}$				22mm=
		$\frac{3}{8}$					$\frac{7}{8}$		.86614 inch
$\frac{25}{64}$				10mm=	$\frac{57}{64}$				23mm=
	$\frac{13}{32}$			.39370 inch		$\frac{29}{32}$			.90551 inch
$\frac{27}{64}$				11mm=	$\frac{59}{64}$				
		$\frac{7}{16}$		.43307 inch			$\frac{15}{16}$		24mm=
$\frac{29}{64}$					$\frac{61}{64}$				.94488 inch
	$\frac{15}{32}$			12mm=		$\frac{31}{32}$			25mm=
$\frac{31}{64}$				.47244 inch	$\frac{63}{64}$				.98425 inch
		$\frac{1}{2}$		13mm=					
				.51181 inch					
							1	1.	

### Unit Conversion Table

cc	x	.0610	=	cu in
cc	x	.02816	=	fl oz (imp)
cc	x	.03381	=	fl oz (U S)
cu in	x	16.39	=	cc
fl oz (imp)	x	35.51	=	cc
fl oz (U S)	x	29.57	=	cc
ft-lbs	x	12	=	in-lbs
ft-lbs	x	.1383	=	kg-m
gal (imp)	x	4.546	=	liters
gal (imp)	x	1.201	=	gal (U S)
gal (U S)	x	3.7853	=	liters
gal (U S)	x	.8326	=	gal (imp)
grams	x	.03527	=	oz
in	x	25.40	=	mm
in-lbs	x	.0833	=	ft-lbs
in-lbs	x	.0115	=	kg-m
kg	x	2.2046	=	lb
kg	x	35.274	=	oz
kg/cm <sup>2</sup>	x	14.22	=	lbs/sq in
kg-m	x	7.233	=	ft-lbs
kg-m	x	86.796	=	in-lbs
km	x	.6214	=	miles
lb	x	.4536	=	kg
lb/sq in	x	.0703	=	kg/cm <sup>2</sup>
liter	x	28.16	=	fl oz (imp)
liter	x	33.81	=	fl oz (U S)
liter	x	.8799	=	qt (imp)
liter	x	1.0567	=	qt (U S)
meter	x	3.281	=	ft
mile	x	1.6093	=	km
mm	x	.03937	=	in
oz	x	28.35	=	grams
qt (imp)	x	1.1365	=	liters
qt (imp)	x	1.201	=	qt (U S)
qt (U S)	x	.9463	=	liters
qt (U S)	x	.8326	=	qt (imp)
°C → °F:		$\frac{9(^{\circ}\text{C} + 40)}{5}$	=	°F
°F → °C:		$\frac{5(^{\circ}\text{F} + 40)}{9}$	=	°C

### List of Abbreviations

ABDC	.....	after bottom dead center
ATDC	.....	after top dead center
BBDC	.....	before bottom dead center
BDC	.....	bottom dead center
BTDC	.....	before top dead center
cc	.....	cubic centimeters
cu in	.....	cubic inches
fl oz	.....	fluid ounces
ft	.....	foot, feet
ft-lbs	.....	foot-pounds
gal	.....	gallon, gallons
hp	.....	horsepower
in	.....	inch, inches
in-lbs	.....	inch-pounds
kg	.....	kilogram, kilograms
kg/cm <sup>2</sup>	.....	kilograms per square centimeter
kg-m	.....	kilogram-meters
km	.....	kilometer
kph	.....	kilometers per hour
lb, lbs	.....	pound, pounds
lbs/sq in	.....	pounds per square inch
ℓ	.....	liter
m	.....	meter, meters
mi	.....	mile, miles
mm	.....	millimeters
mph	.....	miles per hour
oz	.....	ounce, ounces
psi	.....	pounds per square inch
qt	.....	quart, quarts
rpm	.....	revolutions per minute
sec	.....	second, seconds
SS	.....	standing start
TDC	.....	top dead center
"	.....	inch, inches

---

# SHOP MANUAL

---



---

## KZ Series

---

# Foreword

This manual is designed primarily for use in a properly equipped shop by motorcycle mechanics although it contains enough detail and basic information to make it useful to the motorcycle user who desires to carry out his own basic maintenance and repair work. Since a certain basic knowledge of mechanics, the proper use of tools, and workshop procedures must be understood in order to carry out maintenance and repair satisfactorily, the adjustments, maintenance, and repair should be carried out only by qualified mechanics whenever the owner has insufficient experience or has doubts as to his ability to do the work so that the motorcycle can be operated safely.

In order to perform the work efficiently and to avoid costly mistakes, the mechanic should read the text, thoroughly familiarizing himself with the procedures before starting work, and then do the work carefully in a clean area. Whenever special tools or equipment is specified, makeshift tools or equipment should not be used. Precision measurements can only be made by using the proper instruments, and the use of substitute tools may adversely affect safe operation of the motorcycle.

This manual is divided into the following four sections:

(1) Adjustment

The adjustment section gives the procedure for all adjustments which may become necessary periodically and which do not involve major disassembly.

(2) Disassembly

This section shows the best method for the removal, disassembly, assembly, and installation which are necessary for maintenance and repair. Since assembly and installation are usually the reverse of disassembly and removal, assembly and installation are not explained in detail in many cases. Instead, assembly notes and installation notes are provided to explain special points.

(3) Maintenance and Theory of Operation

The procedures for inspection and repair are described in detail in this section. An explanation on the structure and functioning of each of the major parts and assemblies is given to enable the mechanic to understand better what he is doing.

(4) Appendix

The appendix in the back of this manual contains miscellaneous information, including a special tool list, a torque table, a table for periodic maintenance, and a troubleshooting guide.

Since this Shop Manual is based on the first production units of the KZ400, there may be minor discrepancies between the actual vehicle and the illustrations and text in this manual. Major changes and additions pertaining to later year units will be explained in a supplement following the appendix or by a new edition.

Places marked by an asterisk (\*) indicate where improvements have been made in the text over the original edition or where the information only applies to a newer model.

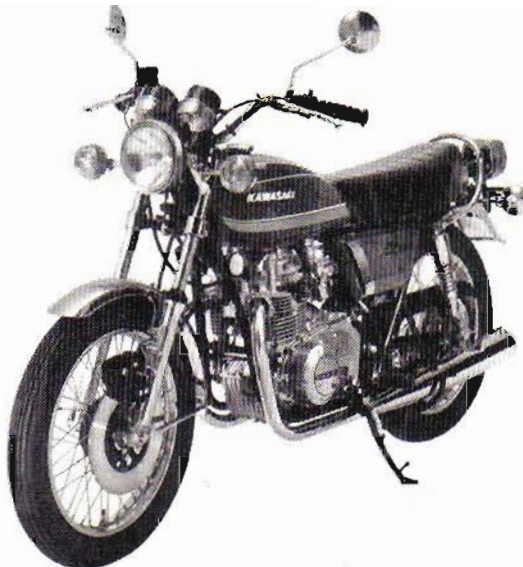

# Table of Contents

FOREWORD .....	1	NEUTRAL INDICATOR SWITCH .....	52
SPECIFICATIONS .....	5	ENGINE OIL PUMP .....	53
ENGINE PERFORMANCE CURVES .....	7	EXTERNAL SHIFT MECHANISM .....	53
RUNNING PERFORMANCE CURVES ..	8	TRANSMISSION .....	55
ADJUSTMENT		KICKSTARTER .....	62
THROTTLE CABLES .....	9	OIL PRESSURE RELIEF VALVE .....	63
CARBURETORS .....	9	BALANCER MECHANISM .....	64
CLUTCH .....	11	CRANKSHAFT, CAMSHAFT CHAIN .....	66
SPARK PLUGS .....	12	CAMSHAFT CHAIN GUIDE (FRONT) .....	70
IGNITION TIMING .....	12	CAMSHAFT CHAIN GUIDE (REAR) .....	70
VALVE CLEARANCE .....	14		
CAMSHAFT CHAIN .....	15	FRONT WHEEL .....	71
STEERING .....	16	REAR WHEEL .....	72
WHEEL BALANCE .....	17	TIRE, TUBE .....	75
FRONT BRAKE LEVER .....	17	RIM .....	76
REAR BRAKE .....	17	SPOKE .....	76
BRAKE LIGHT SWITCH .....	19	DISC BRAKE .....	76
DRIVE CHAIN .....	19	DRIVE CHAIN .....	81
REAR SHOCK ABSORBERS .....	20	REAR SPROCKET, WHEEL COUPLING .....	82
HEADLIGHT .....	20	HANDLEBAR .....	83
HORN .....	21	CLUTCH CABLE .....	84
DISASSEMBLY		THROTTLE CABLES .....	85
ENGINE .....	22	SPEEDOMETER CABLE .....	86
AIR CLEANER ELEMENT .....	26	TACHOMETER CABLE .....	86
OIL FILTER .....	26	SPEEDOMETER .....	86
MUFFLERS .....	27	TACHOMETER .....	86
FUEL TANK .....	27	HEADLIGHT UNIT .....	87
CARBURETORS .....	27	INDICATOR LIGHTS .....	87
ROCKER ARMS .....	29	IGNITION SWITCH .....	87
CAMSHAFT .....	32	FRONT FORK .....	87
CYLINDER HEAD .....	34	STEERING STEM .....	90
VALVES, VALVE GUIDES .....	37	STEERING STEM BEARING .....	92
CYLINDER BLOCK .....	39	SWING ARM .....	93
PISTON, PISTON RINGS .....	40	REAR SHOCK ABSORBERS .....	95
DYNAMO FIELD COIL .....	41	MAINTENANCE & THEORY OF	
DYNAMO ARMATURE .....	43	OPERATION	
DYNAMO ROTOR, STARTER MOTOR		AIR CLEANER .....	96
CLUTCH .....	44	CARBURETORS .....	96
STARTER MOTOR CHAIN & SPROCKETS ..	45	CAMSHAFT .....	102
STARTER MOTOR .....	45	CAMSHAFT CHAIN, CHAIN GUIDES .....	103
IGNITION COIL .....	47	ROCKER ARMS, SHAFTS .....	104
CONTACT BREAKER .....	47	CYLINDER HEAD, VALVES .....	104
CONDENSER .....	47	CYLINDER BLOCK, PISTONS .....	108
TIMING ADVANCER .....	47	CRANKSHAFT, CON-RODS .....	111
CLUTCH, PRIMARY CHAIN .....	48	BALANCER MECHANISM .....	113
CLUTCH RELEASE .....	50	CLUTCH .....	115
ENGINE SPROCKET .....	51	PRIMARY CHAIN .....	118

TRANSMISSION . . . . .	119
KICKSTARTER . . . . .	122
ENGINE LUBRICATION . . . . .	123
<hr/>	
FUEL TANK . . . . .	127
WHEELS . . . . .	128
TIRES . . . . .	128
RIM, SPOKES . . . . .	128
AXLE . . . . .	131
GREASE SEALS, WHEEL BEARINGS . . . . .	131
REAR WHEEL COUPLING . . . . .	132
DRIVE CHAIN . . . . .	132
SPROCKETS . . . . .	133
DISC BRAKE . . . . .	134
REAR BRAKE . . . . .	139
STEERING STEM . . . . .	141
FRONT FORK . . . . .	142
REAR SHOCK ABSORBERS . . . . .	145
SWING ARM . . . . .	146
MUFFLERS . . . . .	147
<hr/>	
DYNAMO . . . . .	147
RECTIFIER . . . . .	150
REGULATOR . . . . .	151
BATTERY . . . . .	154
IGNITION SYSTEM . . . . .	157
TIMING ADVANCER . . . . .	159
SPARK PLUGS . . . . .	159
STARTER MOTOR CIRCUIT . . . . .	160
STARTER MOTOR CLUTCH, CHAIN . . . . .	163
IGNITION SWITCH . . . . .	164
HEADLIGHT CIRCUIT . . . . .	164
BRAKE LIGHT CIRCUIT . . . . .	165
TURN SIGNALS . . . . .	167
HORN . . . . .	168
SPEEDOMETER, TACHOMETER . . . . .	168
<b>APPENDIX</b>	
SPECIAL TOOLS . . . . .	169
PERIODIC MAINTENANCE . . . . .	172
TORQUE TABLE . . . . .	175
POINTS REQUIRING USE OF A NON-PERMANENT LOCKING AGENT . . . . .	177
TROUBLESHOOTING GUIDE . . . . .	178
WIRING DIAGRAM . . . . .	181
<b>INDEX</b> . . . . .	183



# Specifications

## Dimension

Overall length	2,080 mm
Overall width	810 mm
Overall height	1,120 mm
Wheelbase	1,360 mm
Road clearance	125 mm
Dry weight	170 kg
Fuel tank capacity	14 ℓ

## Performance

SS ¼ mile	14.8 sec
Climbing ability	24°
Braking distance	15 m @50kph
Minimum turning radius	2.3 m

## Engine

Type	SOHC 2 cylinder, 4 stroke, air-cooled	
Bore and stroke	64 x 62 mm	
Displacement	398 cc	
Compression ratio	9.0 : 1	
Maximum horsepower	35 HP @8,500 rpm	
Maximum torque	3.17 kg-m @7,500 rpm	
Valve timing		
Inlet	Open	26° BTDC
	Close	74° ABDC
	Duration	280° Total
Exhaust	Open	68.5° BBDC
	Close	31.5° ATDC
	Duration	280° Total
Carburetors	Keihin CVB 36 x 2	
Lubrication system	Forced lubrication (wet sump)	
Engine oil	SE class SAE 10W40	
Engine oil capacity	Less filter	2.6 ℓ
	Total incl. filter	3.0 ℓ
Starting system	Electric & kick	
Ignition system	Battery & coil	
Ignition timing	From 15° BTDC @1,500 rpm to 40° BTDC @2,670 rpm	
Spark plugs	ND W-24ES or NGK B-8ES	

## Transmission

Type	5-speed, constant mesh, return shift	
Clutch	Wet, multi disc	
Gear ratio: 1st	2.571 (36/14)	
2nd	1.684 (32/19)	
3rd	1.273 (28/22)	
4th	1.040 (26/25)	
5th	0.889 (24/27)	
Primary reduction ratio	2.435 (56/23)	
Final reduction ratio	3.000 (45/15)	
Overall drive ratio	6.493 (5th)	

## 6 SPECIFICATIONS

### Electrical Equipment

Generator (Dynamo)	Nippon Denso 021000-3560
Regulator	Nippon Denso 026000-2490
Ignition coil	Nippon Denso 029700-3430
Battery	Yuasa 12N12A-4A-1 12V 12AH
Starter	Mitsuba SM242
Headlight type	Sealed Beam
Headlight	12V 50/35W
Tail/Brake light	12V 8/27W
Speedometer light	12V 3.4W x 2
Tachometer light	12V 3.4W x 2
Neutral indicator light	12V 3.4W
High beam indicator light	12V 1.7W
Turn signal lights	12V 23W x 4
Turn signal indicator light	12V 3.4W
Oil pressure indicator light	12V 3.4W
Brake light failure indicator light	12V 3.4W
Horn	12V 2.5A

### Frame

Type	Tubular, double-cradle
Steering angle	41° to either side
Castor	63°
Trail	102 mm
Tire size	3.25S-18 4PR, ribbed tread
	3.50S-18 4PR, universal tread
Suspension	Telescopic fork
	Swing arm
Suspension stroke	135 mm
	80 mm
Front fork oil capacity (each fork)	150~170 cc
Front fork oil type	SAE 5W20

### Brakes

Type	Disc brake
	Internal expansion, leading-trailing
Rear brake drum inside dia. and width	180 x 30 mm
Disc diameter	277 mm

Specifications subject to change without notice.

# Engine Performance Curves

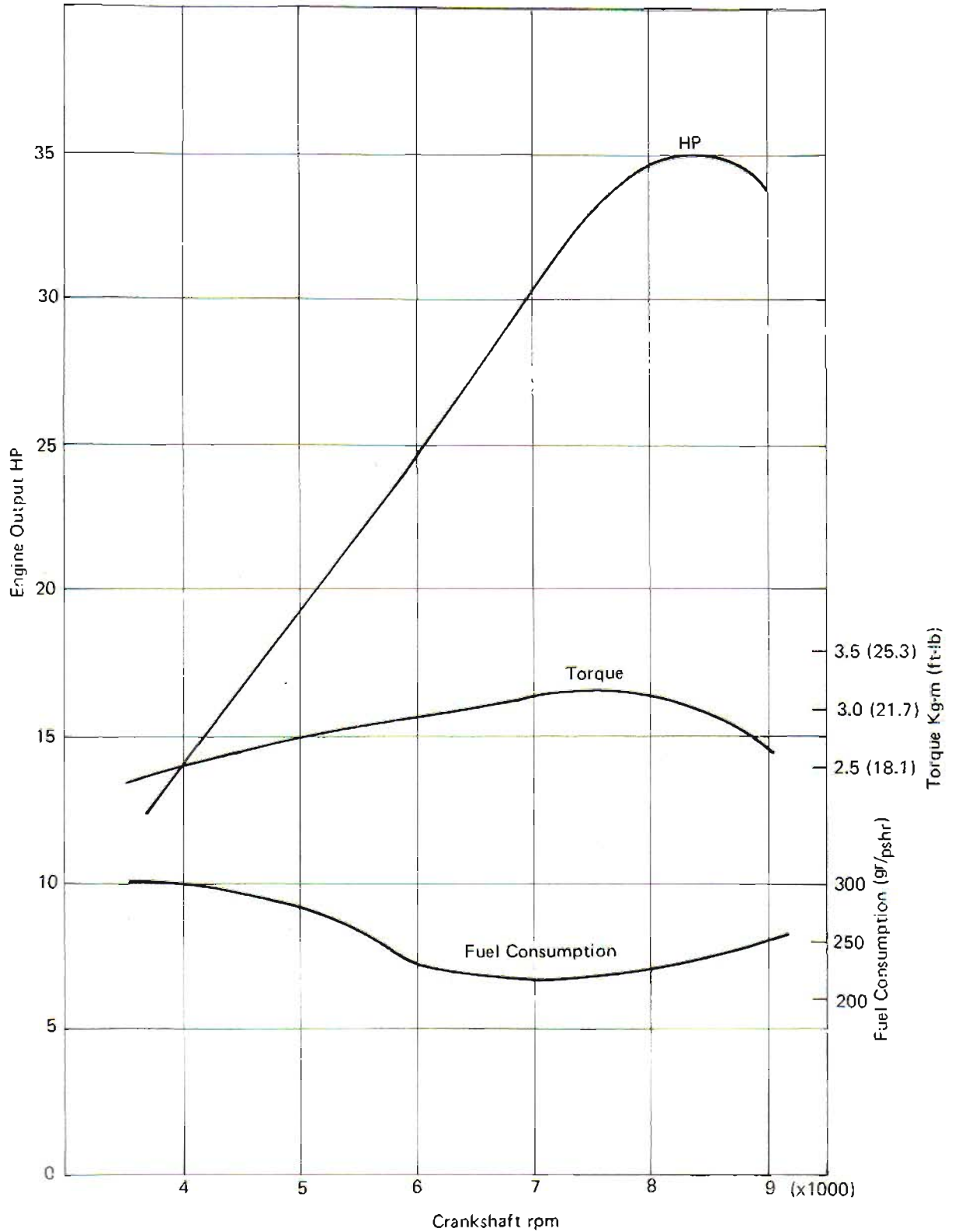

# Running Performance Curves

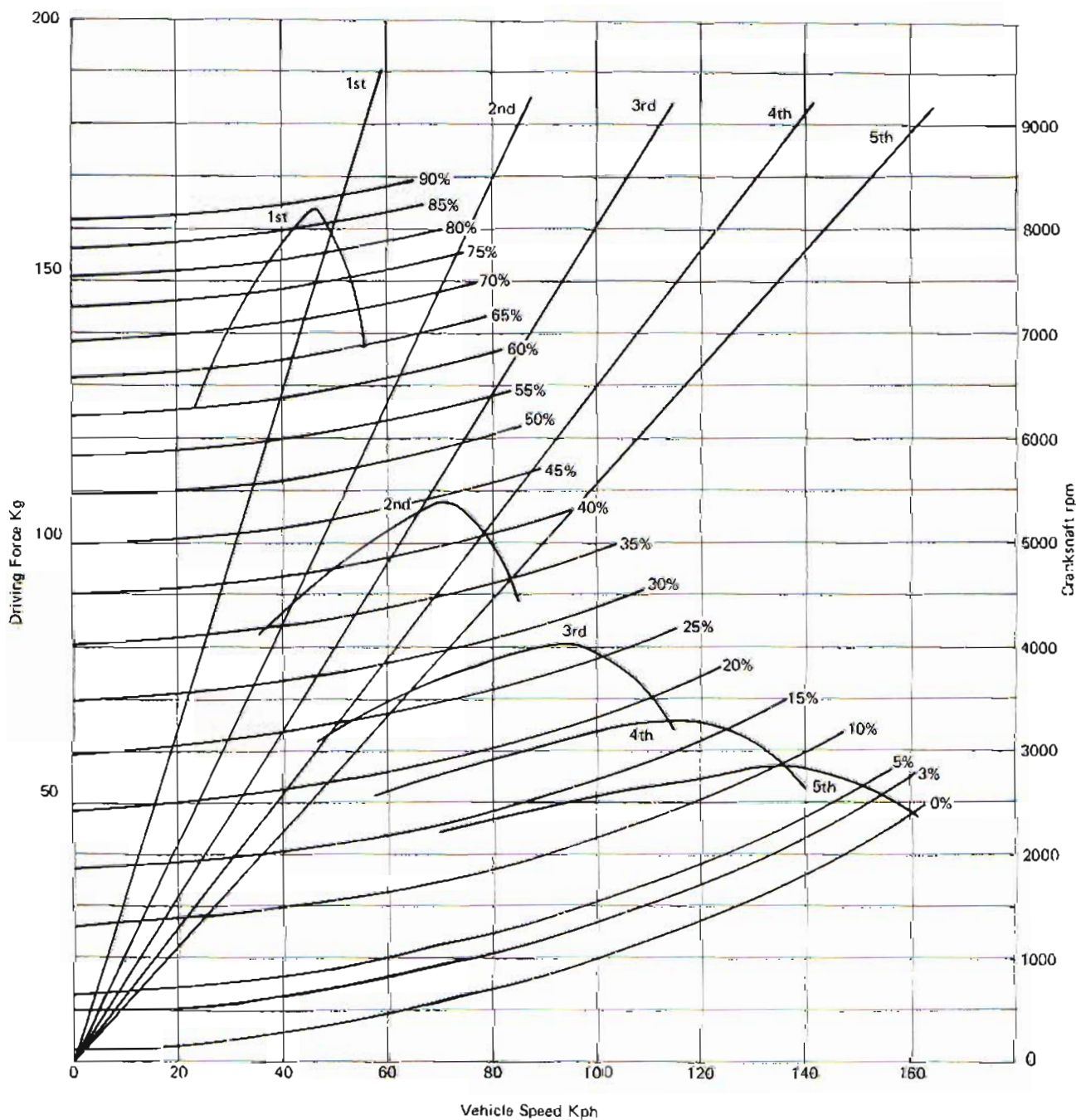

# Adjustment

## THROTTLE CABLES

There are two throttle cables, the accelerator throttle cable for opening the butterfly valve and the decelerator throttle cable for closing them. If the cable adjustment is too loose from either cable stretch or maladjustment, the excessive play in the throttle grip will mean a delay in throttle response, especially at low rpm. Also, the butterfly valves may not open fully at full throttle. On the other hand, if the cable adjustment is too tight, the throttle will be too sensitive and hard to control, and the idling speed will be too high.

- Screw in fully the lock nuts and adjusting nuts at the upper end of the throttle cables so as to give the throttle grip plenty of play.

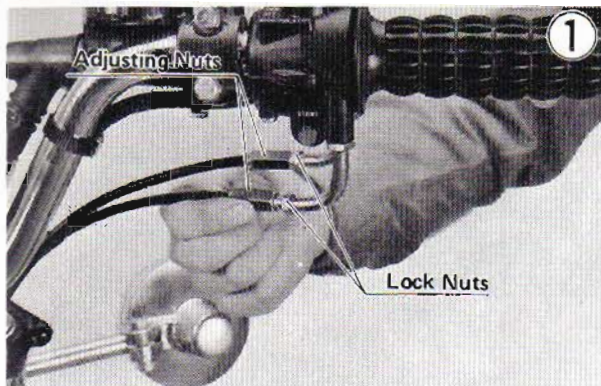

- Turn back the decelerator throttle cable adjusting nut 3 turns. There must still be play in the throttle grip; if there is not, loosen the lock nut at the lower end of the decelerator throttle cable, turn the adjuster to create a small amount of play, and retighten the lock nut.

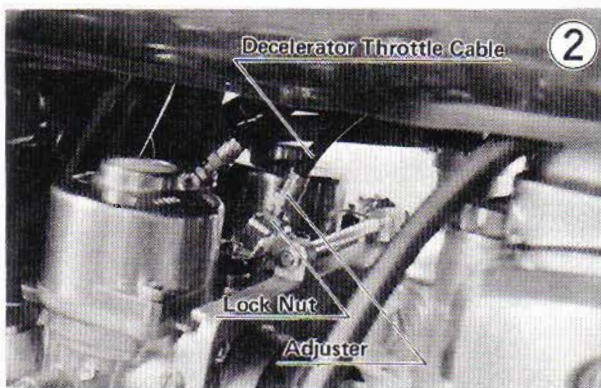

- Turn back the accelerator throttle cable adjusting nut until just where the throttle grip play is virtually gone, and tighten the lock nut.

- Turn in the decelerator throttle cable adjusting nut until the desired amount of throttle grip play is obtained. Tighten the lock nut.



## CARBURETORS

Although some internal carburetor parts can be adjusted by replacement, repositioning, etc., these adjustments are covered in the Maintenance Section of this manual. The following procedure covers the idling adjustment, which is the adjustment necessary in periodic maintenance and whenever the idling setting has been disturbed. This procedure also includes the necessary steps for obtaining proper carburetor synchronization.

When the idling speed is too low, the engine may stall, and when the idling speed is too high, the fuel consumption becomes excessive, and a resulting lack of engine brake may make the motorcycle difficult to control. Poor carburetor synchronization will cause unstable idling, sluggish throttle response, and reduced engine power and performance.

The following procedure consists of four parts: preliminary checks, preliminary adjustment (sometimes necessary), idling adjustment, and carburetor synchronization.

### Preliminary Checks

- In order to obtain correct idling adjustment, first check and then correct, if necessary, the following:
  - Valve clearance (Pg. 14 )
  - Engine oil (Pg. 173)
  - Spark plugs (Pg. 12 )
  - Ignition timing (Pg. 12 )
  - Cylinder compression (Pg. 109)

### Preliminary Adjustment

If the engine idling is especially rough, it may be necessary to make the following adjustment before making the idling adjustment:

## 10 ADJUSTMENT

- With the carburetors removed (Pg. 27, cable removal not necessary), change the position of the pulley stop screw if necessary so that the pulley rotation is stopped at the point where the butterfly valves are parallel to the carburetor bore. Tighten the lock nut after alteration of the screw position.

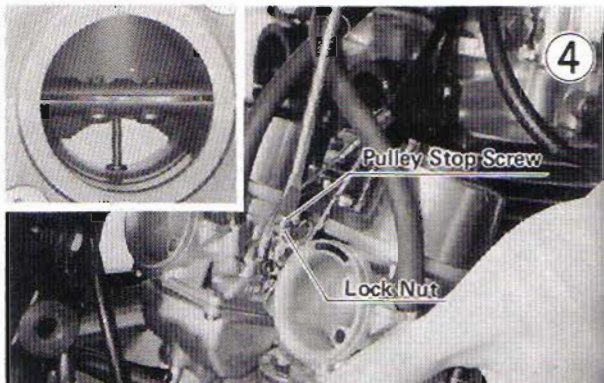

- Install the carburetors (Pg. 28), and check the throttle grip play (Pg. 9).

### Idling Adjustment

- Start the engine, and warm it up for 5 minutes.
- Back out the throttle stop screw until the engine is at the lowest rpm that it turns over smoothly.



- Turn both pilot screws to where engine rpm is highest.

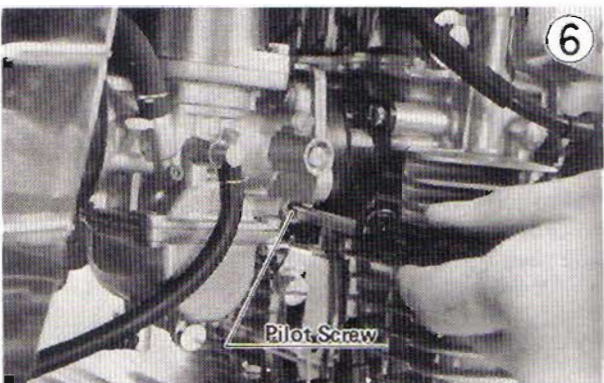

- Adjust idling speed to 1,100 ~ 1,300 rpm by turning the throttle stop screw.
- See if the engine rpm rises when the pilot screw positions are altered. If it rises, repeat the last three steps.

- Screw in each pilot screw 1/16 turn after the highest idle position has been determined.
  - Turn the throttle grip a few times to make sure that the idling speed does not change. Readjust if necessary.
- NOTE:** With the engine idling, turn the handlebar to either side. If handlebar movement changes idling speed, then the throttle cables may be improperly adjusted or incorrectly routed, or else they may be damaged. If cable adjustment does not clear up the problem, find the cause and repair it.

### Carburetor Synchronization

- Remove the vacuum plugs from each carburetor, and attach the vacuum gauge and adapter (special tools).



- With the engine running at idling speed, close down the vacuum gauge intake valves until gauge needle flutter is less than 3 cm Hg. Normal vacuum gauge reading is 22 ~ 27 cm Hg.

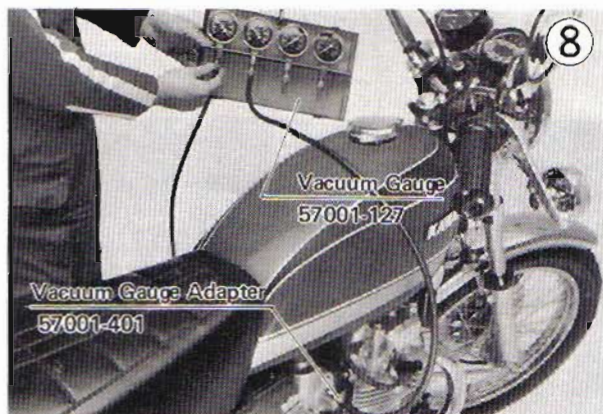

- If there is a difference of more than 1 cm Hg between the two gauges, stop the engine, remove the fuel tank (Pg. 27), and use the balance adjuster (special tool) on the balance adjusting screw to alter screw position to where the difference in readings is below 1 cm Hg. Run the engine with the fuel left in the float bowls. When the screw is properly positioned, tighten the lock nut, stop the engine, and install the fuel tank (Pg. 27).

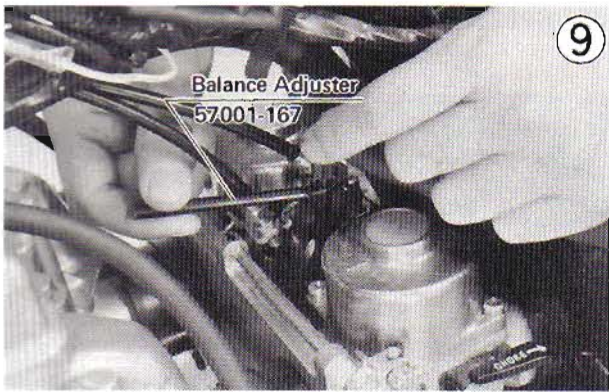

- With the engine running, turn both pilot screws so that the vacuum gauge reading is 22~27 cm Hg, and then turn each pilot screw in 1/16 turn.
  - Detach the vacuum gauges, and screw in the vacuum plugs.
  - Adjust the idling speed to 1,100 ~ 1,300 rpm with the throttle stop screw.
- If a set of vacuum gauges is not available, carry out the following steps for carburetor synchronization.
- Listen to exhaust noise, and place your hands at the rear of the mufflers to feel exhaust pressure.



- If there is a difference in noise or exhaust pressure between the cylinders, stop the engine, remove the fuel tank (Pg. 27), and use the balance adjuster (special tool) on the balance adjusting screw to alter screw position to where the difference is minimized. Run the engine with the fuel left in the float bowls. When the screw is properly positioned, tighten the lock nut, stop the engine, and install the fuel tank (Pg. 27).



- \* • Adjust the idling speed to 1,100 ~ 1,300 rpm with the throttle stop screw.

### CLUTCH

Stretching of the clutch cable causes the clutch lever to develop excessive play. Too much play will prevent the lever from fully disengaging the clutch and will result in shifting difficulty and possible clutch or transmission damage. Most of the play must be adjusted out, but a small amount has to be left so that the clutch release lever will function properly.

Besides cable stretch, clutch plate wear also causes the clutch to go out of adjustment. This wear causes the play between the push rod and the adjusting screw gradually to diminish until the push rod touches the adjusting screw. When this play is lost, the clutch will not engage fully, causing the clutch to slip.

**NOTE:** Even though there is the proper amount of play at the clutch lever, clutch lever play alone cannot be used to determine whether or not the clutch requires adjustment.

The adjustment procedure which follows compensates for both cable stretch and plate wear.

- Slide up the dust cover off the adjusting nut at the center of the clutch cable.
- Screw in fully the lock nut and adjusting nut at the center of the clutch cable to give the cable plenty of play.



- Loosen the lock nut at the clutch lever just enough so that the adjuster will turn freely, and then turn the adjuster to make a 5~6 mm gap between the adjuster and lock nut.

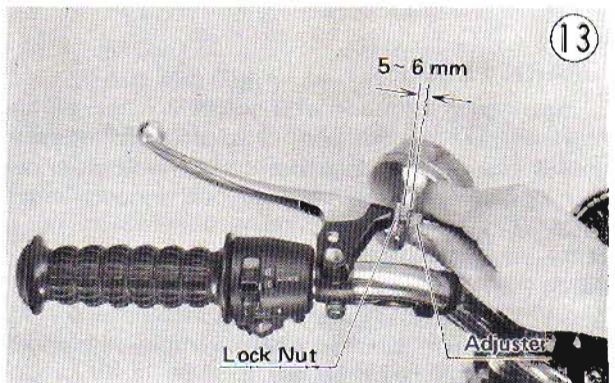

## 12 ADJUSTMENT

- Remove the clutch adjusting cover.
- Loosen the lock nut, and back out the clutch adjusting screw 3 or 4 turns.

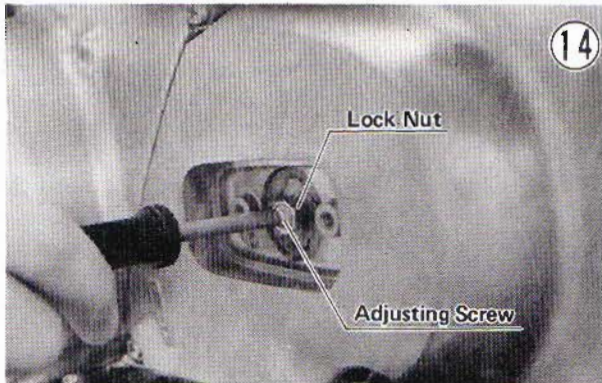

- Turn in the adjusting screw to where it becomes suddenly hard to turn. This is where the clutch begins to engage.
- Back out the adjusting screw  $\frac{1}{2}$  turn from that point, and tighten the lock nut.
- Take up all the cable play with the adjusting nut at the center of the cable, and then tighten the lock nut. Slide the dust cover back down.
- Turn the adjuster at the clutch lever so that the clutch lever will have 2~3 mm of play as shown in Fig. 15, and then tighten the lock nut.

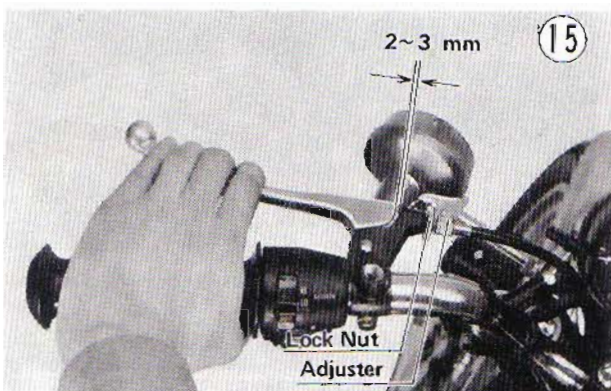

- Replace the clutch adjusting cover.

## SPARK PLUGS

Spark plug electrode wear will widen the gap and cause missing and difficulty in starting. Too narrow a gap as a result of maladjustment will also result in poor performance since the small gap will produce only a weak spark.

- Remove the spark plugs using a spark plug wrench.
- Clean off the electrodes, and measure the gap with a wire-type thickness gauge. The gap should be 0.7~0.8 mm; if it is not, bend the outer electrode with a suitable tool to obtain the correct gap.

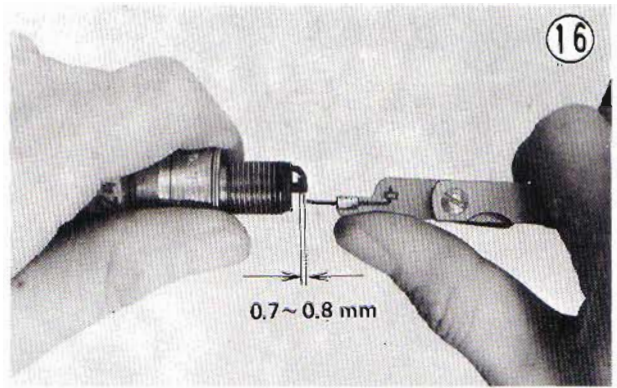

- Tighten the spark plugs into the cylinder head with 2.5~3.0 kg-m (18.5~22.0 ft-lbs) of torque.

## IGNITION TIMING

Incorrect ignition timing can cause poor performance, knocking, overheating, and serious engine damage. Periodic adjustment will be necessary to compensate for wear of parts, and the ignition timing must be checked whenever ignition related parts have been disassembled or replaced.

Correct ignition timing is achieved by first obtaining the correct maximum contact breaker point gap and then adjusting the position of the adjusting plate. Often the first step returns the timing very close to the correct original setting. Once the timing has been adjusted, it may be checked for accuracy by the use of a strobe light.

- Leaving the ignition switch turned off, turn the engine stop switch to one of the OFF positions.
- Remove the contact breaker cover.
- Using a 17 mm wrench on the crankshaft, turn the engine until the contact breaker points are at their widest opening.

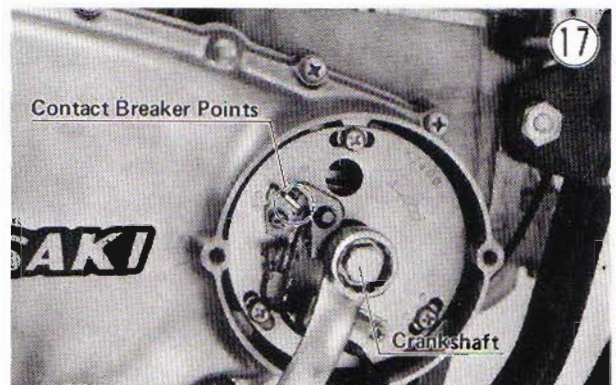

- Determine the size of the point gap with a thickness gauge. The proper gap is 0.3~0.4 mm.
- If the gap is incorrect, loosen the contact breaker base screw, open the points using a slot screwdriver on the contact breaker base pry point, and insert a blade thickness of 0.35 mm between the points. Remove the slot screwdriver, tighten the contact breaker base screw, and

remove the blade(s). Again turn the crankshaft, and recheck the maximum point gap.

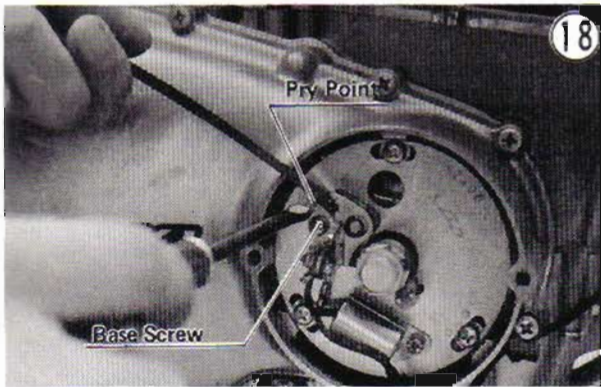

- Turn the crankshaft so that the "F" mark on the timing advancer is aligned with the timing mark as shown in Fig. 19.

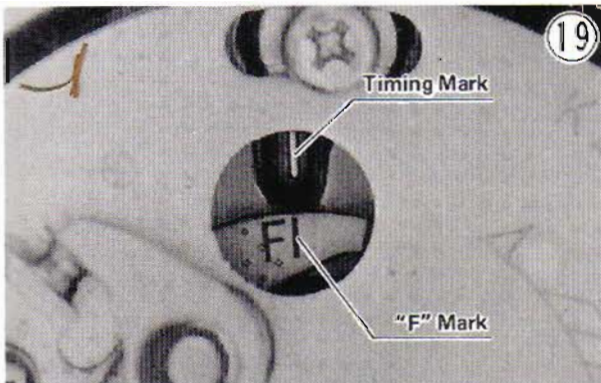

- Connect an ohmmeter set to the R x 1 range across the contact breaker points by securing one lead to chassis ground (such as the crankcase) and attaching or holding the other lead firmly on the contact breaker spring or to the contact breaker lead.



- Loosen the contact breaker plate screws (3) just enough to allow the plate to move.
- Using a screwdriver on the contact breaker plate pry point, turn the plate until the contact breaker points are just at the point of opening. The ohmmeter needle

starts to rise when the points just begin to open. At this point, tighten the contact breaker plate screws (3).



- Turning the crankshaft counterclockwise, check to see if, when the needle jumps, the "F" mark is aligned with the timing mark. If not, readjust.
- Disconnect the ohmmeter leads, and turn the engine stop switch back to the RUN position.
- Connect up a strobe light in the manner prescribed by the manufacturer in order to check the ignition timing under operating conditions. One example is shown in Fig. 22.

Ignition Timing Test

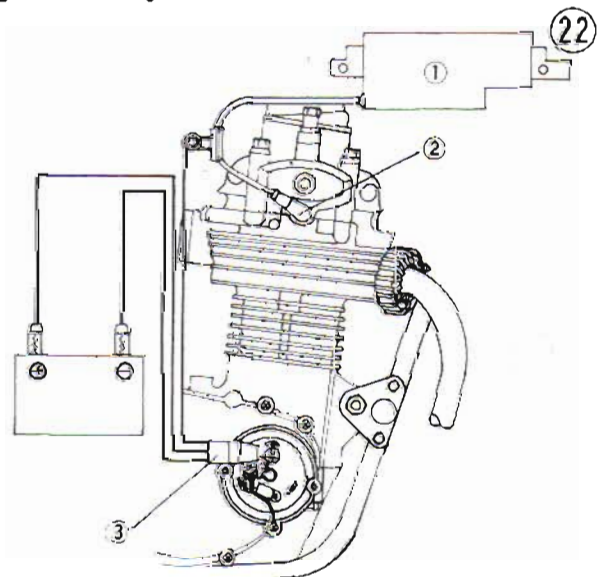

- 1. Ignition Coil
- 2. Spark Plug Cap
- 3. Strobe Light

- Start the engine, and direct the light at the timing mark. At idling speed the timing mark and the "F" mark on the timing advancer must be aligned for correct low rpm ignition timing. At 3,000 rpm or higher the timing mark and the pair of lines on the timing advancer as shown in Fig. 23 must be aligned for correct high rpm ignition timing. If both low and high rpm ignition timing are incorrect, adjust the timing as just explained. If either low or high rpm ignition

## 14 ADJUSTMENT

timing is correct but the other is not, examine the timing advancer mechanism (Pg. 159).

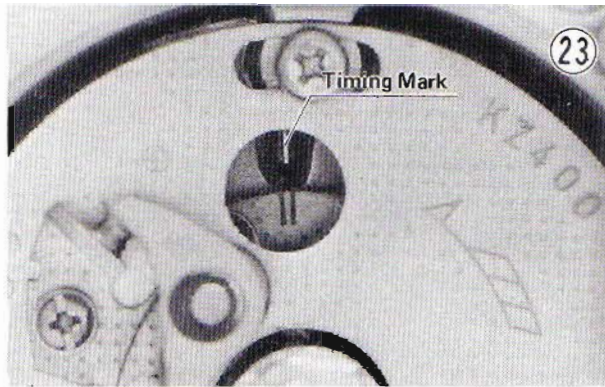

The most precise means to set the maximum point gap is to use a dwell angle tester instead of a thickness gauge. If a dwell angle tester is used to set the gap, substitute the following steps for the first five steps in the above procedure:

- Remove the contact breaker cover.
- Connect the dwell angle tester—lead to chassis ground (such as the frame or crankcase) and the + lead to the contact breaker spring or some exposed part of the contact breaker lead.



- If a dwell angle tester calibrated in degrees is used, turn the selector knob to the lowest cam lobe setting.



- Start the engine, and let it idle.
- Note the reading on the tester. The dwell angle specification is  $185 \sim 195^\circ$  for a tester calibrated in degrees and  $51 \sim 54\%$  for one calibrated in percentage. If the tester setting is for more than one cam lobe, the reading on the tester must be multiplied by the cam lobe number to obtain the correct dwell angle.
- If the dwell angle is not the same as the specification, loosen the contact breaker base screw just enough so that a slot screwdriver at the contact breaker pry point will be able to change the gap, adjust the gap until the dwell angle specification is obtained, and then tighten the screw.

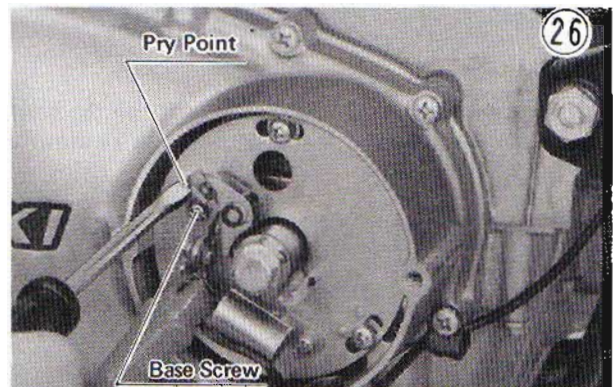

- Stop the engine, disconnect the tester, and replace the contact breaker cover.
- NOTE:** The dwell angle is the angular range for which the contact breaker heel is off the cam lobe allowing the current to flow to the ignition coil primary winding.

## VALVE CLEARANCE

Valve and valve seat wear decreases valve clearance, upsetting valve timing. If valve clearance is left unadjusted, the wear will eventually cause the valves to remain partly open, which lowers performance, burns the valves and valve seats, and may cause serious engine damage.

Valve clearance for each valve should be checked and, if incorrect, adjusted in accordance with the periodic maintenance chart (Pg. 172) and anytime that clearance may have been affected by disassembly.

When carrying out adjustment, be careful to adjust within the specified clearance. Adjusting to a larger value will both disturb valve timing and cause engine noise.

**NOTE:** Valve clearance must be checked when the engine is cold.

- Remove the contact breaker cover.

## ADJUSTMENT 15

- Remove the valve clearance adjuster plugs (4) and the cylinder head cover caps (2).

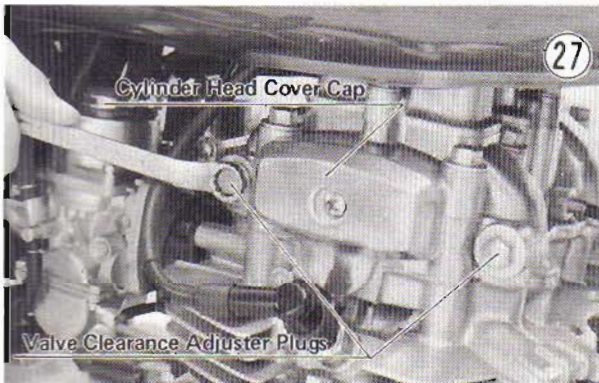

- Using a 17 mm wrench, turn the crankshaft counterclockwise while watching the movement of the inlet valve (the valve to the rear). When the valve has just finished opening and closing (moving downward and returning upward), turn the crankshaft in the same direction (counterclockwise) for about another  $\frac{1}{4}$  turn until the "T" mark (the line adjoining the "T") on the timing advancer aligns with the timing mark.

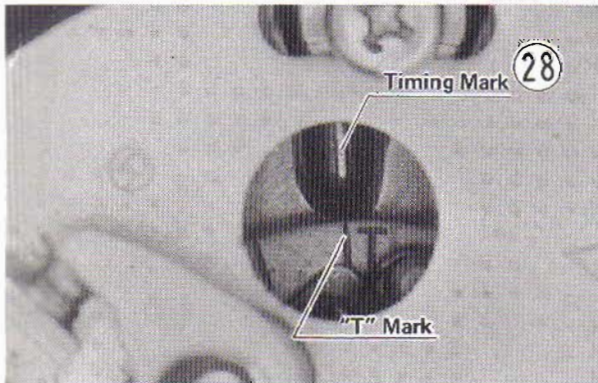

- At this crankshaft position, the piston in the right cylinder is at the end of its compression stroke such that the inlet and exhaust valve for the right cylinder can be checked for clearance and then adjusted if necessary. The correct clearance for the inlet and exhaust valves is 0.08 ~ 0.13 mm.
- Check the valve clearance by slipping a 0.10 mm thickness gauge blade between the rocker arm and the tip of the valve stem. If the clearance is correct, there will be a slight resistance as the blade is moved.



- If the valve clearance is incorrect, loosen its rocker shaft lock nut, and turn the shaft with a screwdriver towards (+) for extra clearance. Slip the thickness gauge blade between the valve and rocker, and turn the rocker shaft towards (-) so that the valve and rocker are separated only by the blade. Pull out the blade, and tighten the lock nut with 2.5 ~ 3.0 kg-m (18 ~ 22 ft-lbs) of torque while using the valve clearance adjuster (special tool) to keep the rocker shaft from turning. Recheck the clearance, and readjust if necessary.



**NOTE:** When adjusting valve clearances, always keep the rocker shaft punch mark on each shaft positioned inward facing the (+) (-) marks.

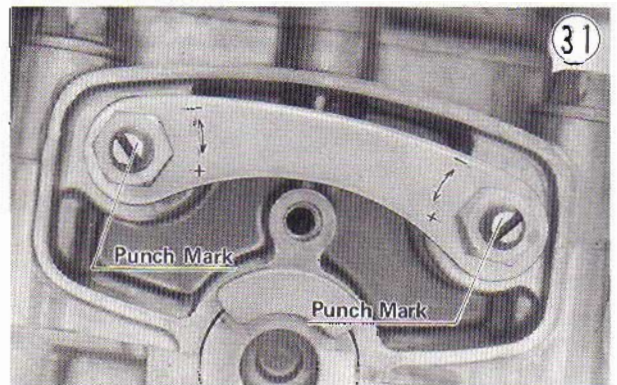

- After finishing with the right cylinder valves, turn the crankshaft counterclockwise one full turn so that the "T" mark again aligns with the timing mark. Check the left cylinder valves, and adjust if necessary.
- Replace the parts which were removed.

## CAMSHAFT CHAIN

Camshaft chain and chain guide wear causes the chain to develop slack, which will cause noise and may result in engine damage. To keep the chain from making noise, periodic adjustment is necessary in accordance with the periodic maintenance chart (Pg. 172). However, if the adjustment fails to keep the chain from making noise, the chain guides have probably worn past the service limit and will need to be replaced.

## 16 ADJUSTMENT

- Remove the contact breaker cover.
- Remove the chain tensioner cap and O ring.
- Turn the crankshaft counterclockwise while watching the push rod (in the center of the push rod guide) move in and out. Continue turning the crankshaft counterclockwise until the push rod again reaches the inner most position, and then stop.

**CAUTION:** Don't turn the crankshaft backwards (clockwise). Turning the crankshaft backwards may cause improper adjustment.

- Loosen the lock nut, and screw in the push rod guide until the ends of the push rod guide and push rod are flush.

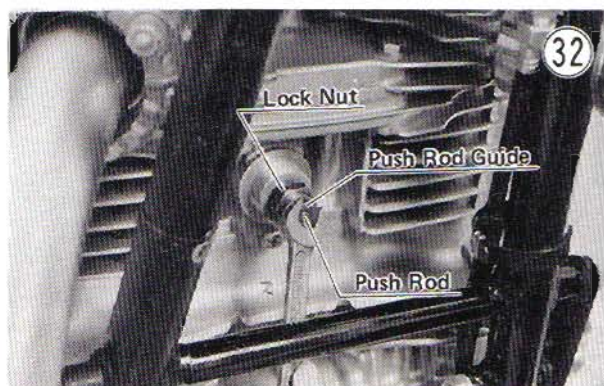

**CAUTION:** Be sure that the ends are flush. If the push rod guide is overtightened so that the push rod sticks out even only 0.5 mm, the tensioner or chain may become damaged.

- Tighten the lock nut, and replace the chain tensioner cap and O ring.
- Replace the contact breaker cover.

## STEERING

For safety, the steering should always be kept adjusted so that the handlebar will turn freely but not have excessive play.

If the steering is too tight, it will be difficult to turn the handlebar quickly, the motorcycle may pull to one side, and the steering stem bearings may become damaged. If the steering is too loose, the handlebar will vibrate, and the motorcycle will be unstable and difficult to steer in a straight line.

To check the steering adjustment, first place a stand or block under the engine so that the front wheel is raised off the ground. Push the handlebar lightly to either side; if it continues moving under its own momentum, the steering is not too tight. Squatting in front of the motorcycle, grasp the lower ends of the front fork at the axle, and push and pull the front end back and forth; if no play is felt, the steering is not too loose.

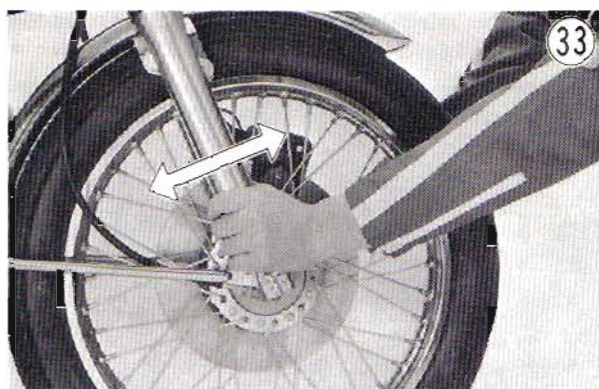

- Put the motorcycle up on its center stand, and jack or prop up the engine so that the front wheel will be off the ground.
- Loosen the steering stem head bolt and the clamp bolt.

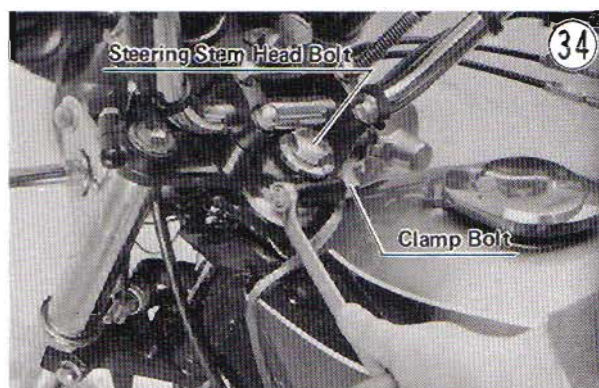

- Using the stem nut wrench (special tool), turn the steering stem lock nut down (clockwise) to tighten the steering or up (counterclockwise) to loosen it.

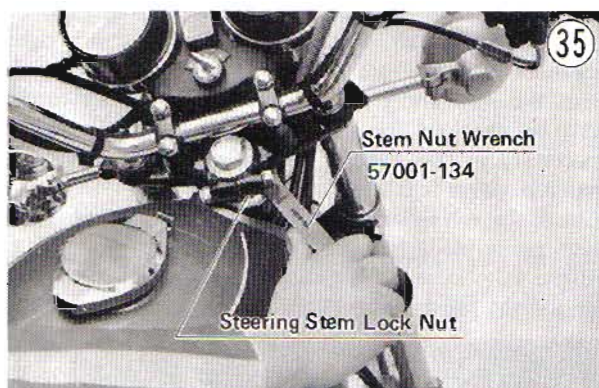

- Tighten down the steering stem head bolt with 5.5 kg-m (40 ft-lbs) of torque.
- Tighten the clamp bolt with 1.6 ~ 1.8 kg-m (12 ~ 13 ft-lbs) of torque.
- Loosen the lower clamp bolts on the left and right shock absorbers to let the tubes reseal themselves, and then tighten the bolts with 2.0 ~ 3.0 kg-m (14.5 ~ 22 ft-lbs) of torque.

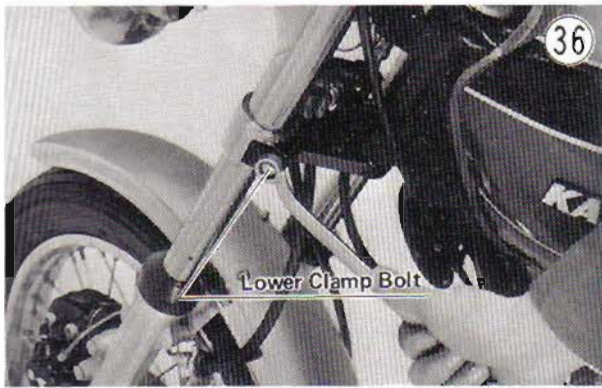

- Check the steering again, and readjust if necessary.

### WHEEL BALANCE

To improve stability and decrease vibration at high speed, the front and rear wheels must be kept balanced.

Check and balance each wheel as follows:

- Remove the wheel (Pgs. 71 & 72).
- Check that all the spokes are tightened evenly.
- Suspend the wheel so that it can be spun freely.
- Spin the wheel lightly, and mark the spoke at the top when the wheel stops.
- Repeat this procedure several times. If the wheel stops of its own accord in various positions, it is well balanced.
- However, if the wheel always stops in one position, attach a balance weight loosely to the marked spoke.



- Rotate the wheel  $\frac{1}{4}$  turn, and see whether or not the wheel stops in its new position. If it does, the correct balance weight is being used.
- If it does not, try other balance weights until the wheel stays in position when rotated  $\frac{1}{4}$  turn.
- Rotate the wheel another  $\frac{1}{4}$  turn and then another  $\frac{1}{4}$  turn to see if the wheel is correctly balanced.
- Repeat the entire procedure as many times as necessary to achieve correct wheel balance, and then clamp on the balance weights firmly using pliers.
- Mount the wheel back onto the motorcycle (Pgs. 71 & 73).

**NOTE:** Balance weights are available from Kawasaki Dealers in 10, 20, and 30 gram sizes. An imbalance of less than 10 grams will not usually affect running stability.

### FRONT BRAKE LEVER

Disc and disc pad wear is automatically compensated for and has no effect on brake lever action. However, the brake lever may occasionally require adjustment due to wear inside the lever assembly itself or in case of lever disassembly. Excessive play must be taken up to keep the lever from vibrating, but enough play must be left to ensure a full braking stroke.

- Straighten the part of the washer that is bent over the side of the adjusting bolt lock nut.
- Loosen the lock nut, turn the adjusting bolt a fraction of a turn so that lever play is under 5 mm, and retighten the lock nut with 1.8 ~ 2.3 kg-m (13 ~ 16.5 ft-lbs) of torque.

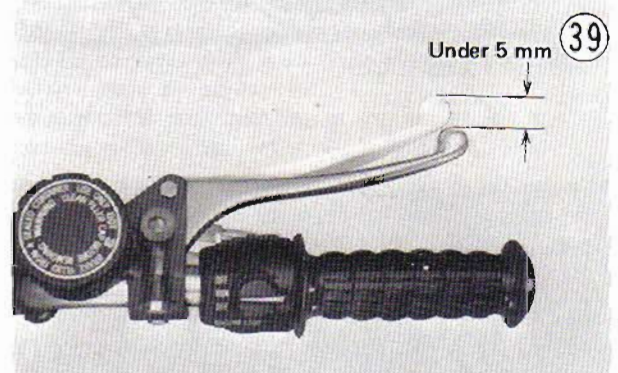
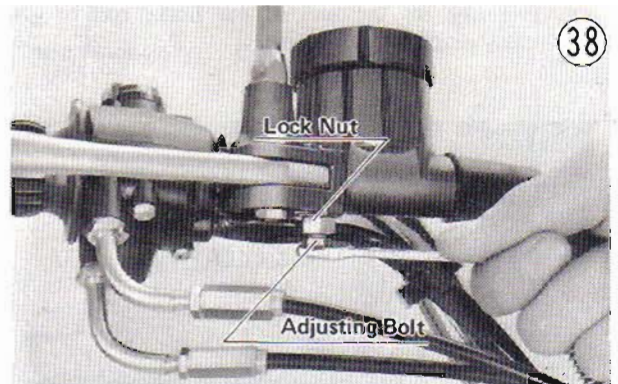

- Bend back part of the washer over the side of the lock nut.

### REAR BRAKE

Brake lining and drum wear causes the rear brake to go out of adjustment, increasing pedal play and decreasing braking effectiveness. Rear brake adjustment to compensate for this actually consists of three successive adjustments: brake pedal position, cam lever angle, and brake pedal travel.

If brake drag is detected during brake adjustment, disassemble the brake (Pg. 73), and inspect for wear or damage (Pg. 139). Also, if the brake pedal does not return to its rest position quickly upon release, inspect the brake for wear or damage.

## 18 ADJUSTMENT

On the outside of the rear brake panel there is a brake lining wear indicator. Whenever the indicator has gone past USABLE RANGE, the brake shoes must be immediately replaced and the other brake parts examined. Adjustment alone cannot compensate for the wear of a brake worn past USABLE RANGE.

### Brake Pedal Position

- When the brake pedal is in its rest position, it should be 20~30 mm lower than the upper surface of the right front foot rest. If it is not, first loosen the adjusting nut on the end of the brake rod to give the brake pedal plenty of play.

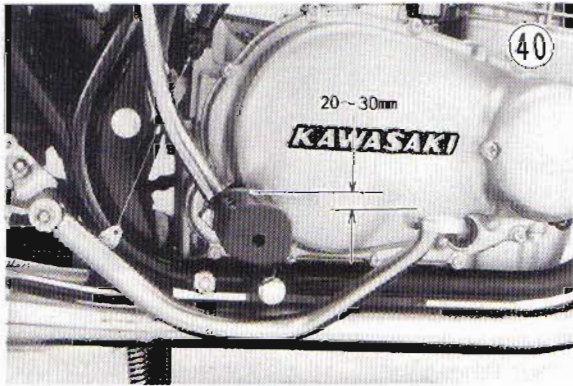

- Loosen the brake pedal adjusting bolt lock nut, turn the adjusting bolt to obtain the correct pedal position, and tighten the lock nut.

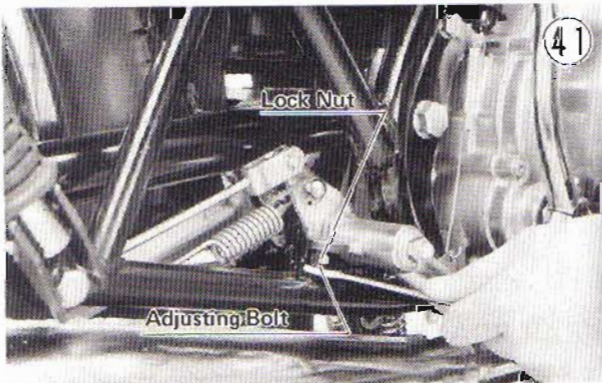

### Cam Lever Angle

- When the brake is fully applied, the brake cam lever should come to an 80~90° angle with the brake rod. If it does not, remove the cam lever, and then remount it at a new position on the shaft for the proper angle.

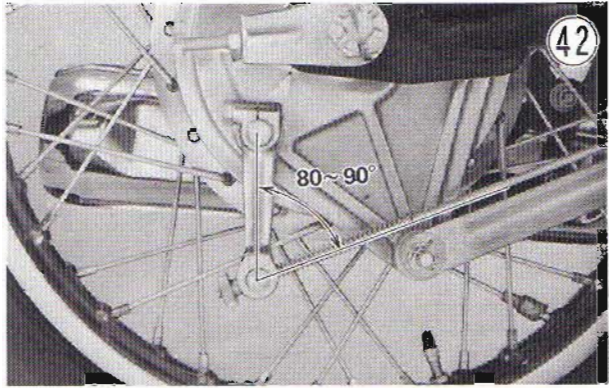

**CAUTION:** Since a cam lever angle greater than 90° reduces braking effectiveness, this adjustment should not be neglected. When remounting the cam, be sure that the position of the indicator on the serrated shaft is not altered. The change in cam lever angle is caused by wear of internal brake parts. Whenever the cam lever angle is adjusted, also check for drag and proper pedal operation, taking particular note of the brake lining wear indicator position. In case of doubt as to braking effectiveness, disassemble and inspect all internal brake parts. Worn parts could cause the brake to lock or fail.

### Brake Pedal Travel

- Turn the adjusting nut on the end of the brake rod so that the brake pedal has 20~30 mm of travel from the rest position to the fully applied position when the brake pedal is pushed down lightly by hand.

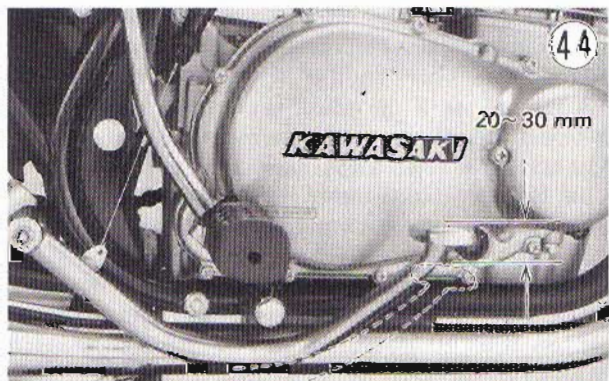
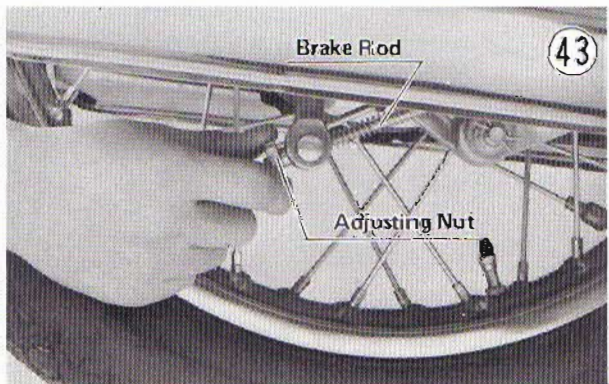

- Rotate the rear wheel to check for brake drag.
- Operate the pedal a few times to see that it returns to its rest position from the fully applied position immediately upon release.
- Check the rear brake light switch adjustment.

## BRAKE LIGHT SWITCH

The front brake light switch, mounted in the stem base, operates hydraulically and is non-adjustable. However, the rear brake light switch, activated by a spring attached to the brake pedal, requires periodic adjustment to compensate for any change in spring shape or tension.

Check the operation of the switch by turning on the ignition switch and depressing the brake pedal. The brake light should go on after 15 mm of pedal travel or shortly before the brake pedal reaches the fully applied position.

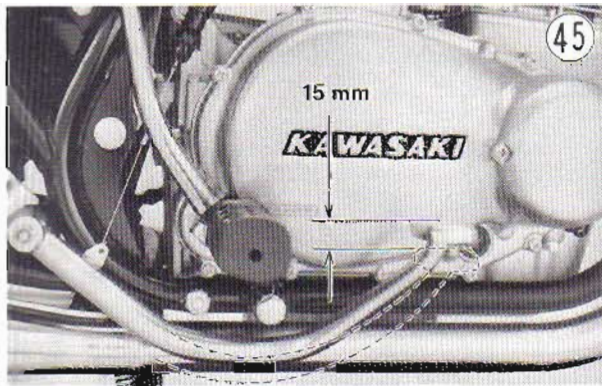

- Turn the switch adjusting nut up or down so that the brake light will go on after the correct amount of brake pedal travel. A higher switch position will make the light go on after less travel.

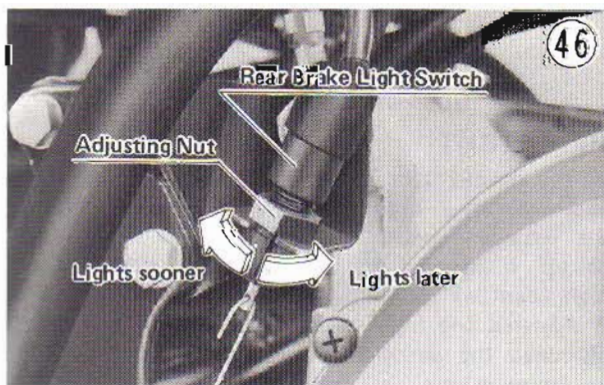

**CAUTION:** To avoid damaging the electrical connections inside the switch, be sure that the switch body does not turn during adjustment.

## DRIVE CHAIN

Chain and sprocket wear causes the chain to lengthen, which results in power loss, accelerated chain and sprocket wear, and increased noise. A lengthened chain which is not adjusted properly may possibly be thrown off the sprockets or break. A chain that has been adjusted too tight will wear excessively and possibly break.

To determine whether or not the chain requires adjustment, first set the motorcycle up on its center stand, rotate the rear wheel to obtain the location of the least slack, and measure the vertical movement midway between the sprockets. If it is less than 15 mm or more than 30 mm, adjust the chain so that the vertical movement will be about 20~25 mm.

### Chain Slack

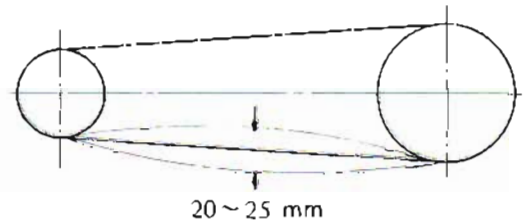

**CAUTION:** A chain worn past the service limit (Pg. 132) should be replaced. Such wear cannot be adequately compensated by adjustment.

- Remove the clip, and loosen the nut at the rear end of the torque link.

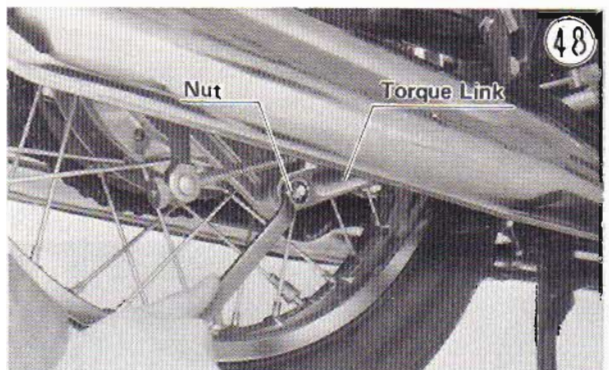

- Remove the axle cotter pin, and loosen the axle nut.



## 20 ADJUSTMENT

- Loosen the coupling sleeve nut.

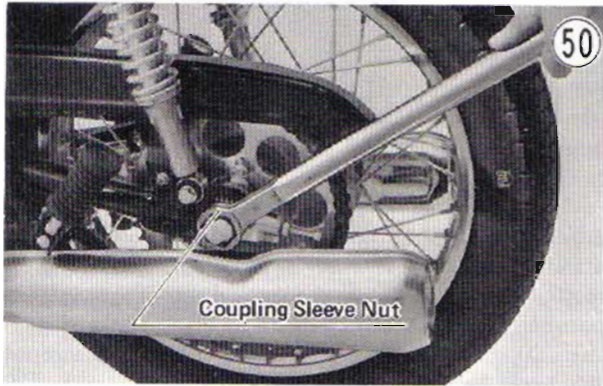

- Loosen the left and right chain adjuster lock nuts.
- If the chain is too tight, back out the left and right chain adjuster bolts, and then kick the wheel forward until the chain is too loose.

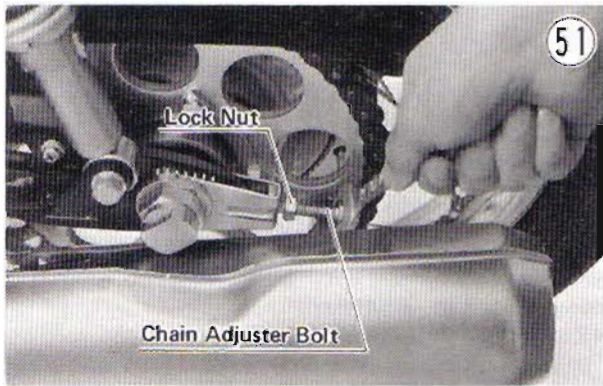

- Turn in the left and right chain adjuster bolts evenly until the drive chain has the correct amount of slack. To keep the chain and wheel aligned, the notch on the left chain adjuster should come to the same swing arm mark that the right chain adjuster notch comes to.

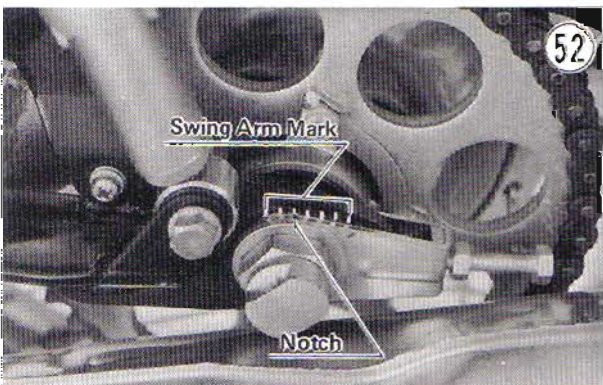

- Tighten both chain adjuster lock nuts, and then tighten the coupling sleeve nut securely.
- Tighten the axle nut with 13~16 kg-m (94~116 ft-lbs.) of torque.

- Rotate the wheel, measure the vertical movement again, and readjust if necessary.
- Insert a new cotter pin through the axle nut and axle.
- Tighten the torque link rear nut with 2.7~3.0 kg-m (19.5~22 ft-lbs) of torque, and replace the clip.
- Check the rear brake adjustment (Pg. 18 ) and the rear brake light switch adjustment (Pg. 19 ).

## REAR SHOCK ABSORBERS

The rear shock absorbers can be adjusted to one of five positions to suit riding conditions. They can be left soft for average riding but should be adjusted harder for high speed riding or riding on bad roads. Shock absorbers adjusted either too soft or too hard adversely affect riding comfort and stability.

- Turn the adjusting sleeve on each shock absorber to the desired position with a hook spanner. The higher the adjusting sleeve is positioned, the stronger the spring tension, and the harder the ride.

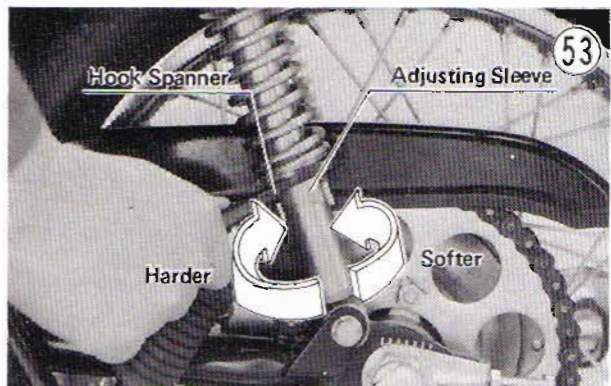

- Check to see that both adjusting sleeves are turned to the same relative position.

## HEADLIGHT

The headlight beam is adjustable both horizontally and vertically. If not properly adjusted horizontally, the beam will point to one side rather than straight ahead. If adjusted too low vertically, neither low nor high beam will illuminate the road far enough ahead. If adjusted too high vertically, high beam will fail to illuminate the road close ahead, and low beam will blind oncoming drivers.

### Horizontal Adjustment:

- Turn in or out the small screw on the headlight rim until the beam points straight ahead.

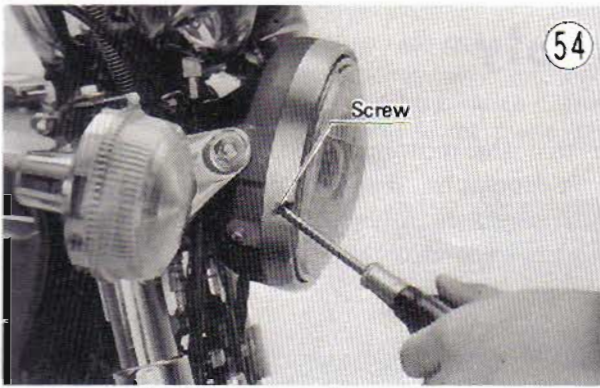

**Vertical Adjustment:**

- Loosen the headlight housing mounting bolts.

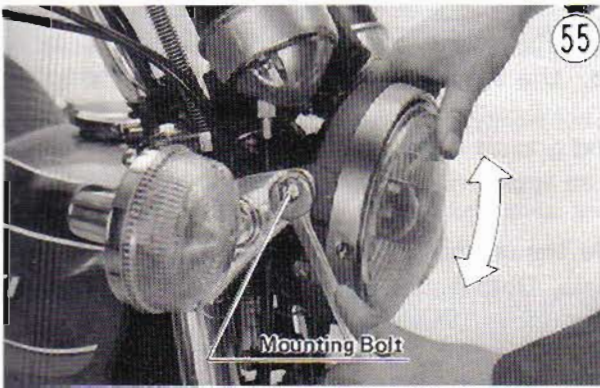

- Move the headlight up or down by hand to where the vertical aim is correct.
- Tighten the headlight housing mounting bolts.

**CAUTION:** Do not turn the adjusting screw in too far since doing so will increase horn current possibly burning out the horn coil.

- Disconnect the black horn leads, and connect an ammeter in series to the horn circuit. The + ammeter lead goes to the horn terminal lead and the - ammeter lead to the remaining lead.
- Fully loosen the adjusting screw lock nut.
- Turn on the ignition key, and keep the horn button pressed while turning the horn adjusting screw. Adjust for the best horn sound while keeping the current between 1.8~2.5 amperes.

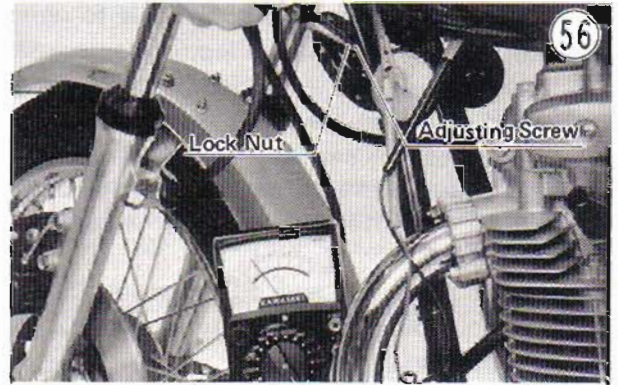

- Tighten the adjusting screw lock nut.

**NOTE:** The horn will not sound properly if it is mounted incorrectly or if any cable or other part is touching it.

**HORN**

The horn contacts wear down after long use and will need to be adjusted from time to time. Turning in the adjusting screw compensates for contact wear. If satisfactory horn performance cannot be obtained by this adjustment when the rest of the electrical system is functioning properly, the horn must be replaced. It can not be disassembled.

**Horn Current Measurement**

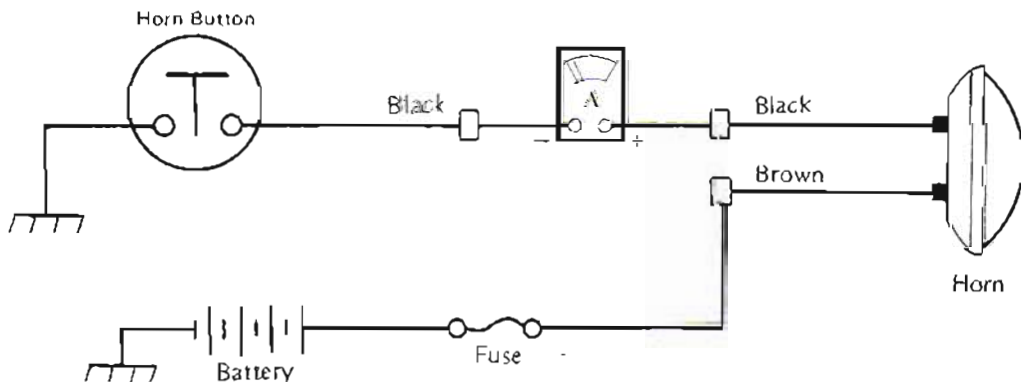

# Disassembly

## INTRODUCTION TO DISASSEMBLY

Detail has not been spared in this section in order that the motorcycle can be not only taken apart but also put back together properly as well. Photographs, diagrams, notes, cautions, and detailed descriptions have been included wherever felt necessary. Nevertheless, even a detailed account has limitations; a certain amount of basic knowledge is also required for successful work.

Especially note the following:

(1) Force

Common sense should dictate how much force is necessary in assembly and disassembly. If a part seems especially difficult to remove or install, stop and examine what may be causing the problem. Whenever tapping is necessary, tap lightly using a plastic hammer. Use an impact driver for screws — particularly for the removal of screws held by a locking agent in order to avoid damaging the screw heads.

(2) Torque

The torque values given in this Shop Manual should always be adhered to. Either too little or too much torque may lead to serious damage. Use a good quality, reliable torque wrench.

(3) Lubricant

Don't use just any oil or grease. Some oils and greases in particular should be used only in certain applications and may be harmful if used in an application for which they are not intended.

(4) Lubrication

Engine wear is generally at its maximum while the engine is warming up and before all the rubbing surfaces have an adequate lubricative film. During assembly oil should be applied to any bearing surface which has lost its lubricative film. Old grease and dirty oil should be cleaned off. Deteriorated grease has lost its lubricative quality and may contain abrasive foreign particles.

(5) Press

A part installed using a press or driver, such as a wheel bearing, should first be coated with oil on its outer or inner circumference so that it will go into place smoothly.

(6) Oil Seals

An oil seal guide is required for certain oil seals during installation to avoid damage to the oil seal lips. Before a shaft passes through an oil seal, apply a little oil on the lips to reduce rubber to metal friction.

(7) Gasket

When in doubt as to the condition of a gasket, replace it for a new one. The fitting surfaces around the gasket should be free of foreign matter and perfectly smooth to avoid oil or compression leaks.

(8) Edges

Watch for sharp edges, especially during major engine disassembly and assembly. Use a clean piece of thick cloth when lifting the engine or turning it over.

## ENGINE

### Removal:

- With the motorcycle on its center stand, place an oil pan beneath the engine, and remove the engine oil drain plug and oil filter to drain out the oil. The drain plug and oil filter may be replaced once all the oil has drained out or later during engine installation.

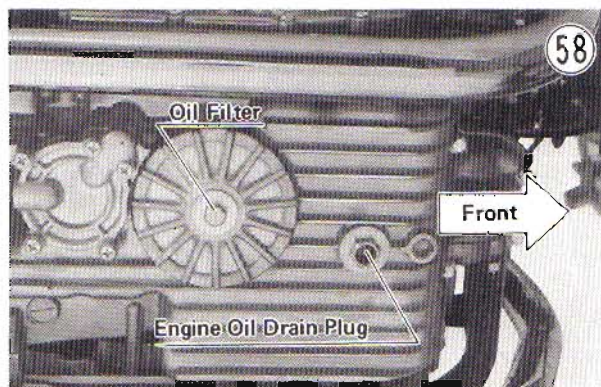

- Remove the fuel tank (Pg. 27).
- Pull off the spark plug lead from each spark plug.
- Disconnect the blue contact breaker lead from where it connects to the blue ignition coil lead, loosen slightly the straps (4) which hold the lead to the frame, and slide the lead free from the frame.

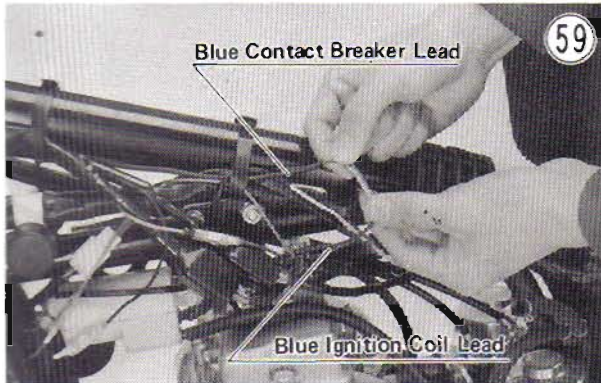

- Unscrew the tachometer cable from the cylinder head cover.
- Pull off the right and left side covers.
- Disconnect the plugs (2) from their sockets under the voltage regulator.

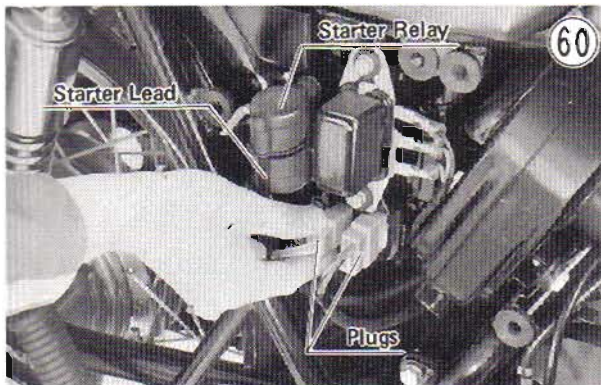

- Remove the starter lead from the starter relay terminal.
- Loosen the clamp which secures the breather hose to the breather cover, slide the clamp out of place, and pull the hose off from where it connects.

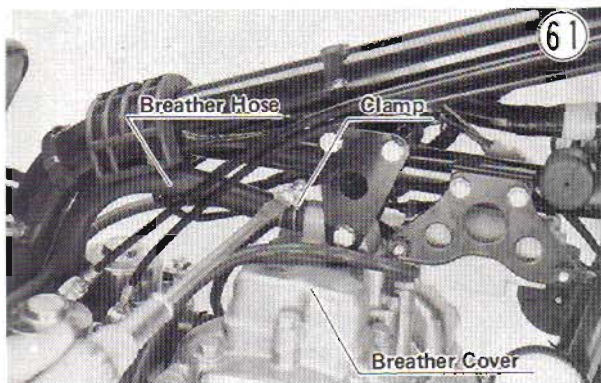

- Loosen the engine intake duct clamp for each carburetor.

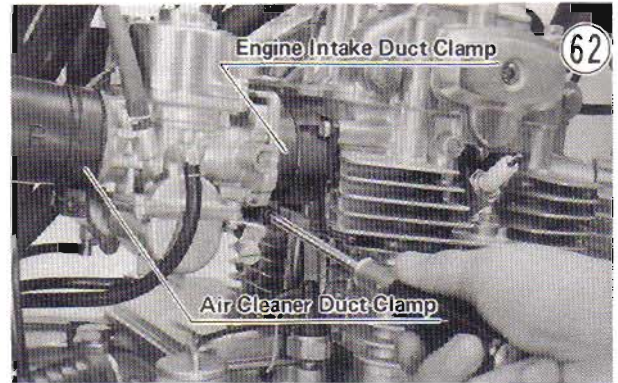

- Loosen the clamp that connects each air cleaner duct to its carburetor, and slip it out of place.
- Slip the carburetors down and out of their ducts, pull the carburetors free, and set them on top of the frame.
- Remove the muffler collar nuts and lock washers (4 ea), and slide each muffler collar off its cylinder head studs.
- Remove each rear foot peg to complete muffler removal. Also, remove the muffler gasket from each exhaust port.
- Check to see that the transmission is in neutral, then take out the shift pedal bolt, and remove the shift pedal.
- Remove the left foot peg bolt, left foot peg, and side stand spring.
- Remove the engine sprocket cover screws (4), and pull the cover free from the crankcase.
- Remove the clip carefully from the drive chain master link with pliers, remove the master link, and remove the drive chain from the engine sprocket.

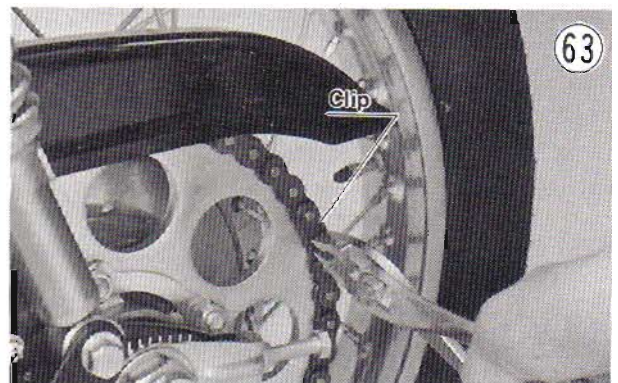

- Remove the bracket connecting the breather cover to the frame.
- Remove the breather cover bolts (4), and remove the cover.
- Remove the rear brake light switch spring.
- Hold the rear brake light switch body steady, and turn the adjusting nut counterclockwise until the lower portion can be pressed inward.
- Pressing inward on the lower portion of the adjusting nut, push the switch up and out of its bracket.

## 24 DISASSEMBLY



- Remove the nuts from the engine mounting bolts (3), and remove each mounting bolt. Be careful not to damage the threads upon removal, raising the engine up a little as necessary. A spacer comes off each of the rear bolts.

### Engine Mountings

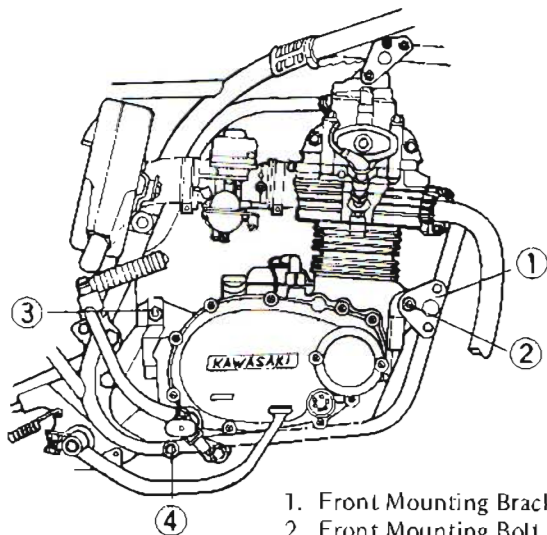

1. Front Mounting Bracket
2. Front Mounting Bolt
3. Rear Upper Mounting Bolt
4. Rear Lower Mounting Bolt

- Remove the left front engine mounting bracket.

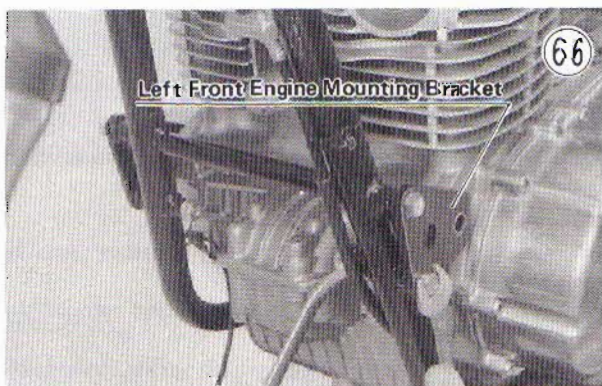

- Loosen the clutch cable straps (2), slide the straps up, and situate the engine sprocket cover so that the clutch cable will not get damaged during engine removal.

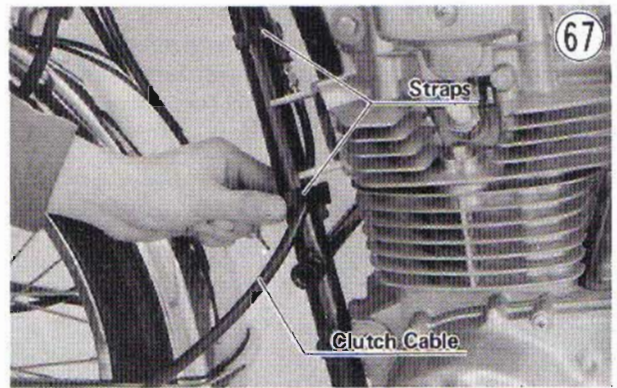

- Lift up on the front of the engine, and then remove it from the left side of the frame, top first and rear last.

### Installation:

- Place the engine into the frame the reverse of how it was removed.
- Replace the left front engine mounting bracket, and tighten first the upper bolt and then the lower with 2.2 ~ 2.6 kg-m (16 ~ 19 ft-lbs) of torque. Each bolt has a lock washer. The clutch cable goes as shown in Fig. 68.

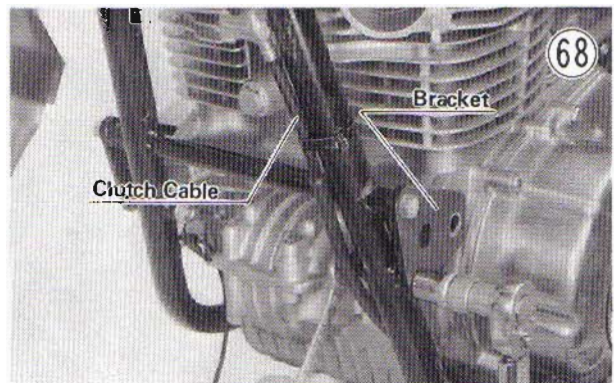

- Lifting the engine as necessary so that the mounting bolt threads do not get damaged, insert the engine mounting bolts. Both rear bolts run through a spacer on the left side.

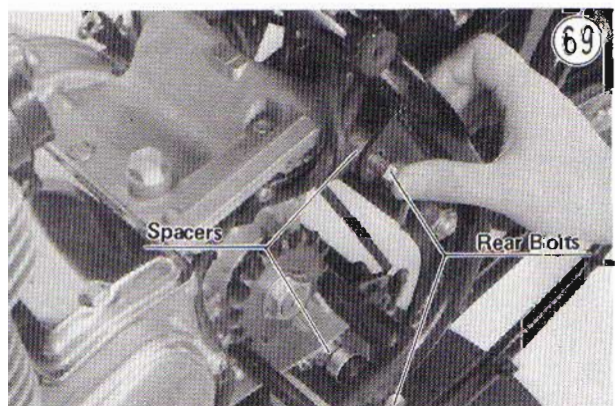

- Replace the lock washers and nuts with the spring side of the nuts facing out, and tighten each nut with 3.5 ~ 4.3 kg-m (25 ~ 31 ft-lbs) of torque.

- NOTE:** Some machines have one or more shims added to the lower spacer. After the nuts are tightened to the proper torque, check to see whether or not the spacer takes up all the space. If not, add one or more shims.
- Replace the rear brake light switch, and fit its spring back in place.
  - Apply liquid gasket if necessary to the breather cover O ring groove to hold the O ring in place for installation.



- Replace the breather cover, and tighten its bolts with 1.8~2.3 kg·m (13~16.5 ft·lbs) of torque. Each bolt has a flat washer.
- Replace the breather cover bracket. Each bolt has a lock washer.
- Fit the drive chain back on the sprockets with the ends on the rear sprocket as shown in Fig. 71.

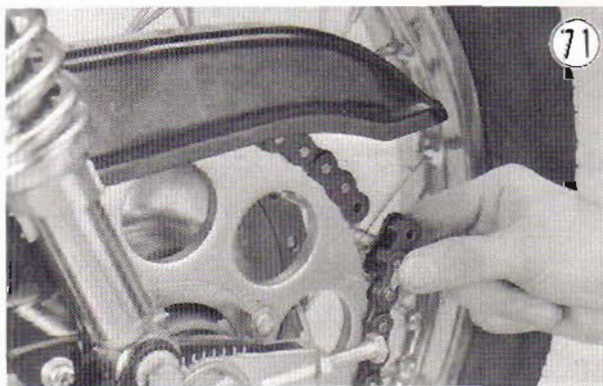

- Replace the chain master link with pliers. The direction of the master link clip should be as shown in Fig. 72.

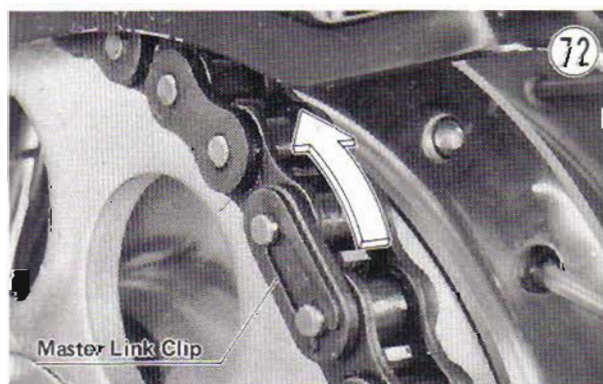

- Replace the engine sprocket cover using the shift shaft oil seal guide (special tool) to protect the oil seal in the cover, and tighten its screws. The wiring is routed in front of the upper mounting bolt spacer.

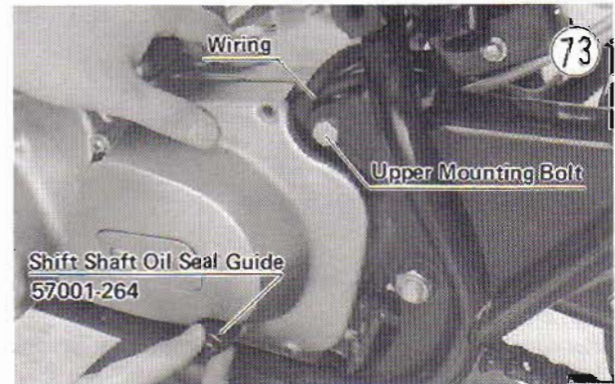

- Secure the clutch cable to the left down tube with the straps.
- For each muffler, fit its gasket and the end of the muffler into its exhaust port, and attach the muffler to the frame tightening its foot peg nut loosely. A lock washer and flat washer go with the nut.
- Fit each split keeper and collar back into place, and tighten the collar nuts evenly to avoid an exhaust leak. There is a lock washer for each nut.

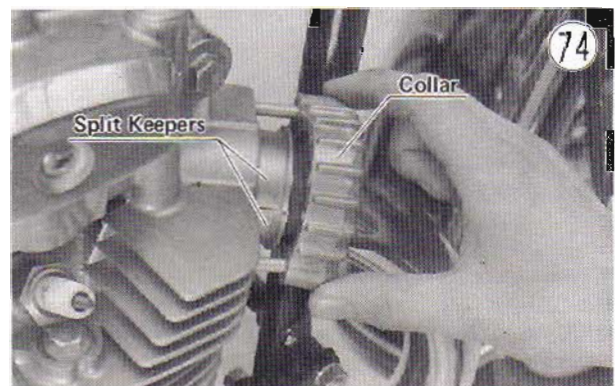

- Tighten the foot peg bolts securely.
- Fit the side stand spring into place, and then secure the left foot peg with its bolt.
- Replace the shift pedal so that its end matches the level of the dynamo cover lower right screw.
- Slip the carburetors back into place the reverse of how they were removed. The throttle cables go along the right side of the top tube.
- Once the ducts are all properly fitted on the carburetors, tighten all four clamps. Route the carburetor tubes (4) to the rear through their guide.

## 26 DISASSEMBLY

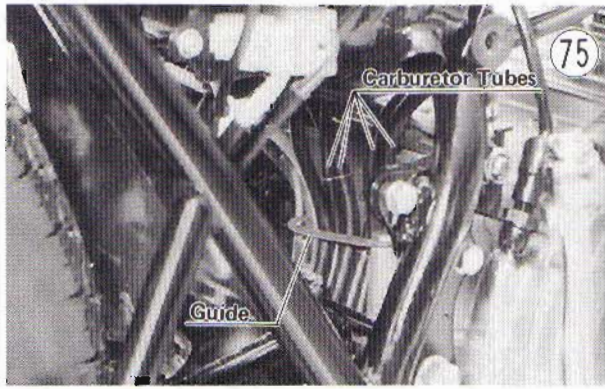

- Fit the breather hose back on the breather cover, and tighten its clamp.
- Reconnect the plugs (2) to their sockets under the voltage regulator.
- Replace the starter lead on the starter relay terminal.
- Replace the right and left side covers.
- Tighten the bottom end of the tachometer cable into its place in the cylinder head cover.
- Run the contact breaker lead through its straps (4), and connect it to the blue ignition coil lead. Tighten the straps.

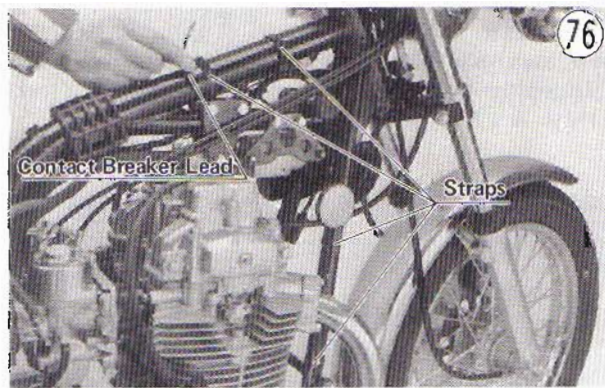

- Connect each spark plug lead onto its spark plug.
- Install the fuel tank (Pg. 27 ).
- Make sure the O rings are in place, and replace the oil filter and drain plug. Tighten the oil filter with 1.5 ~ 2.0 kg-m (11 ~ 14.5 ft-lbs) of torque and the drain plug with 2.0 ~ 2.5 kg-m (14.5 ~ 18 ft-lbs).

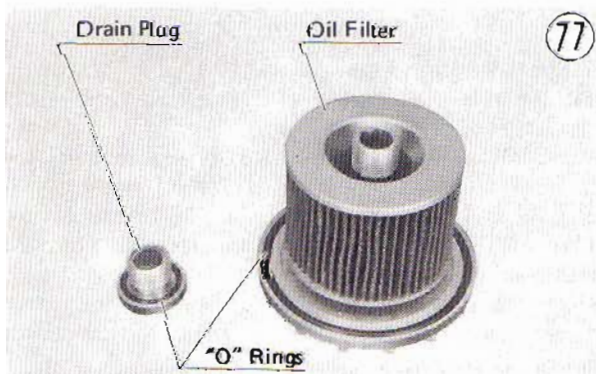

- Fill the engine with oil, check the level (Pg.173), and add more if necessary.
- Check the drive chain slack, and adjust (Pg. 19 ) if necessary.
- Adjust the rear brake light switch (Pg. 19 ).

## AIR CLEANER ELEMENT

### Removal:

- Pull off the left side cover.
- Remove the air cleaner housing side cover screw, and pull off the side cover. The screw has a lock washer and flat washer.



- Pull out the element.

### Installation Note:

- Replace the element so that the element holes match the air cleaner ducts.

## OIL FILTER

### Removal:

- With the motorcycle on its center stand, place an oil pan beneath the engine, and remove the oil filter.

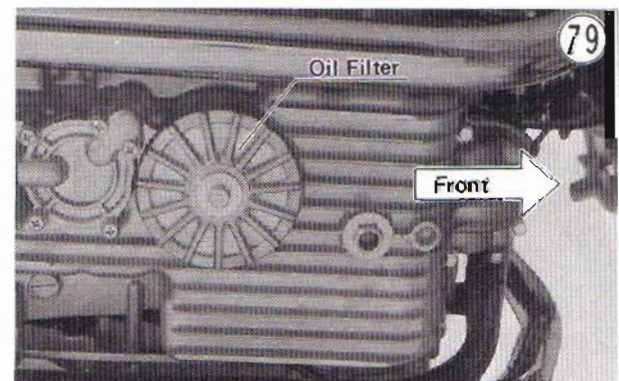

**Installation:**

- Make sure that the O ring is properly in place, and replace the oil filter tightening its bolt with 1.5~2.0 kg-m (11~14.5 ft-lbs) of torque.
- Pour the oil back in, check the level (Pg. 173), and add more if necessary.

**Disassembly:**

- While holding the element steady, turn the bolt to work the element free.
- Remove the flat washer, spring, and pull the filter base off the bolt.

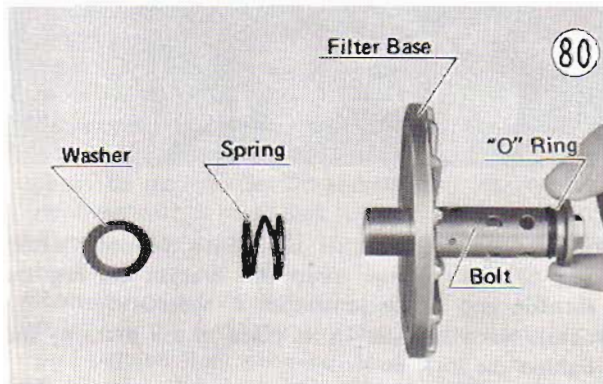

- To remove the bypass valve, drive out the pin, and drop out the spring and piston.

**Assembly:**

- Fit in the piston and spring, and drive in the pin while pressing the spring down.
- Replace either O ring for a new one if deteriorated or damaged.
- Fit the filter base on the bolt, and replace the spring and flat washer.
- Holding the element steady, turn the bolt to work the element into place. Be careful that the element grommets do not slip out of place.

**MUFFLERS****Removal (per muffler):**

- Remove the muffler collar nuts and lock washers, and slide the muffler collar off its cylinder head studs.

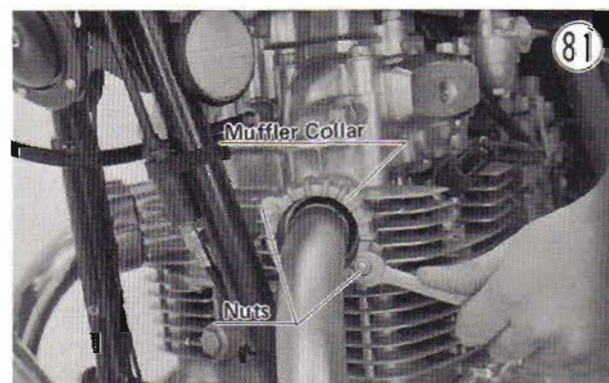

- Remove the rear foot peg to complete muffler removal. Also, remove the muffler gasket from the exhaust port.

**Installation (per muffler):**

- Fit the gasket and the end of the muffler into the exhaust port, and attach the muffler to the frame tightening the foot peg nut loosely. A lock washer and flat washer go with the nut.
- Fit the split keeper and collar back into place, and tighten the collar nuts evenly to avoid an exhaust leak. There is a lock washer for each nut.

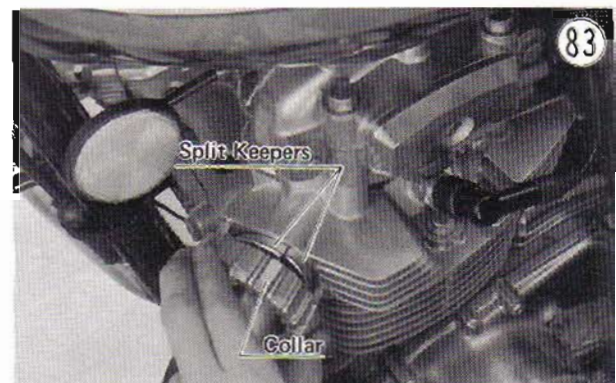

- Tighten the foot peg bolt securely.

**FUEL TANK****Removal:**

- Turn the fuel tap to STOP, slide down the hose clamps, and pull the fuel hoses (2) off the tap.
- Unlock the seat, and swing it open.
- Unhook the rubber retaining band, and pull the fuel tank off towards the rear.

**Installation:**

- Replace the fuel tank, and hook its retaining band.
- Fit the fuel hoses back onto the fuel tap, and slide the clamps back into place.
- Push the seat back down.

**CARBURETORS****Removal:**

- Take off the right and left side covers.

## 28 DISASSEMBLY

- Turn the fuel tap to STOP, slide down the hose clamps, and pull the fuel hoses (2) off the tap.
- Loosen the engine intake duct clamp for each carburetor.
- Loosen the clamp that connects each air cleaner duct to its carburetor, and slip it out of place.

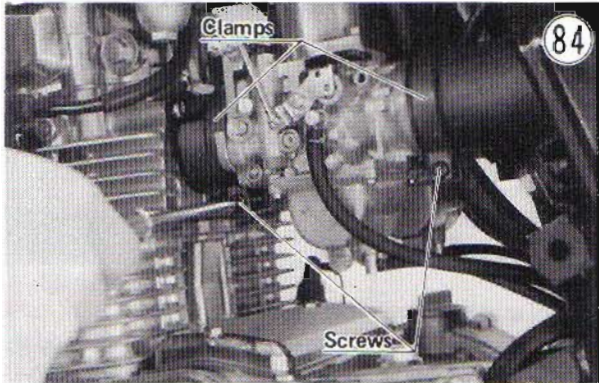

- Slip the carburetors down and out of their ducts to the right side of the motorcycle.
- Screw in fully the lock nuts and adjusting nuts at the upper end of the throttle cables so as to give the throttle grip plenty of play.
- Screw one of the cable adjusters out of its bracket, slip the tip of its inner cable out of the pulley, and then do the same with the other throttle cable to complete carburetor removal.



### Installation:

- If necessary, change the position of the pulley stop screw so that the pulley rotation is stopped at the point where the butterfly valves are parallel to the carburetor bore. Tighten the lock nut after alteration of the screw position.

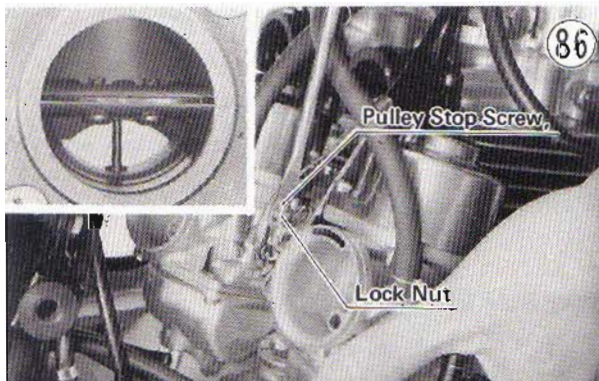

- Fit the tip of the accelerator throttle cable into the rear catch in the pulley, and screw its adjuster down into the bracket all the way.

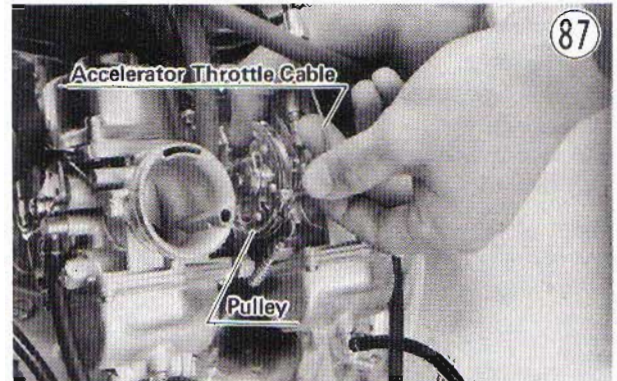

- Fit the tip of the other cable into the other catch, and lift its adjuster onto the bracket turning the throttle grip at the same time if necessary.
- Center each adjuster in its place in the bracket, and tighten the lock nuts.

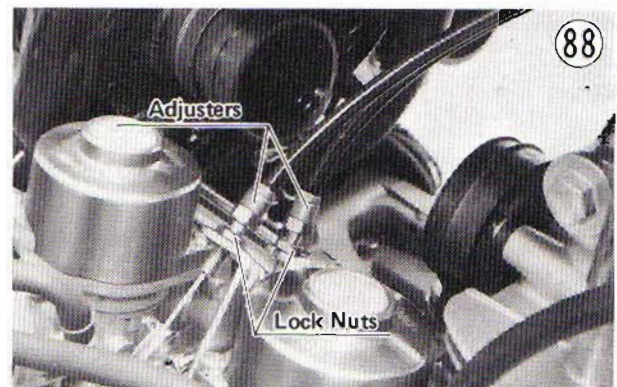

- Slip the carburetors back into place the reverse of how they were removed.
- Once the ducts are all properly fitted on the carburetors, tighten all four clamps.
- Route the carburetor tubes (4) to the rear through their guide.

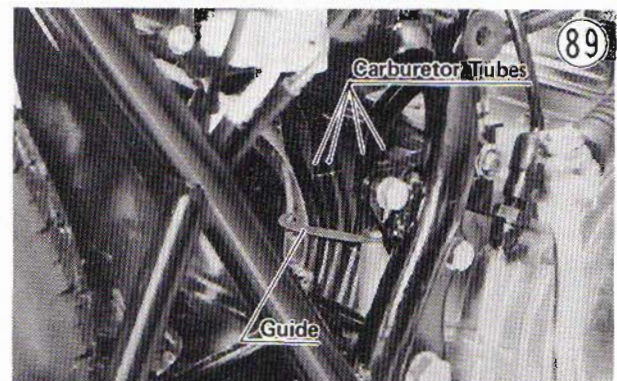

- Fit the fuel hoses back onto the fuel tap, and slide the clamps back into place.
- Replace the right and left side covers.
- Adjust the throttle cables (Pg. 9).

### Upper Chamber and Float Chamber Disassembly:

- Remove the upper chamber screws, and take off the carburetor cap (1).
- Pull out the vacuum piston (3), and take out the vacuum piston gasket (2).
- To remove the jet needle (15), take out the screw (14) and drop out the jet needle.
- To remove the air jets, remove the screw (16) and lock washer (17) and take out the plate (18) and plate gasket (19). The main air jet (20) and slow air jet (21) may be removed with a small slot screwdriver.
- Remove the screws (4) (40), and pull off the float bowl (97).
- Remove the jet keeper (45).
- Push out the float pin (47), remove the float (46), and pull out the float valve needle (37).
- To remove the float valve seat (32), remove its screw and retainer (35), and pull it out.
- To remove the main jet (44) and needle jet (42), pull out the main jet and then drop out the needle jet.
- To remove the starter jet (41), use a large slot screwdriver.
- To remove the pilot jet (39) and slow jet (40), pull out the pilot passage plug (38), and remove them using a small slot screwdriver.

### Upper Chamber and Float Chamber Assembly Notes:

1. Replace any deteriorated gaskets or rubber parts (vacuum piston gasket, air jet gasket, valve seat O ring (34), upper main jet groove O ring (43), pilot passage plug, and float bowl ring (33)) for new ones.
2. Be sure that the float is replaced facing the right way (Pg. 102 Fig. 373).
3. Replace the jet keeper as shown in Fig. 90, and then screw on the float bowl. The jet keeper is used to keep the main jet and pilot passage plug in place.



### Linkage Mechanism and Starter Plunger Unit

#### Disassembly:

- Remove the left carburetor from the mounting plate (1), taking out its screws (2) (87) (88) and slipping it out of its balance adjusting screw connection and choke lever linkage.
- Separate the right carburetor from the mounting plate, removing its screws (2).
- To disassemble the linkage mechanism, first straighten back the linkage bar washer sides which are bent over the bolt, and remove the bolt (81), washer (80), spring (79), and pusher (78).
- Remove the linkage bar C rings (76) and washers (75), and pull off the bar (74).
- Remove the C ring (73) from the pulley screw (62), and pull off the flat washer (72), plastic washer (65), pulley (71), and plastic washer (65).
- Remove the cable bracket (70) and then the pulley spring (64).
- To disassemble the starter plunger unit, unscrew the cap (7), pull out the unit, and slide off the plunger (1). Removal of the right carburetor starter plunger unit requires removal of the cable bracket.

### Linkage Mechanism and Starter Plunger Unit

#### Assembly Note:

- To mount the left carburetor, first fit the choke linkage together, connect the balance adjusting screw connection (96) with the bracket between the washers, and fit the spring between the carburetors. Then fit the choke linkage in place, and replace the mounting plate screws. Use a non-permanent locking agent on each mounting plate screw.

### ROCKER ARMS

#### Removal:

- Remove the fuel tank (Pg. 27).
- Remove the bracket connecting the breather cover to the frame.

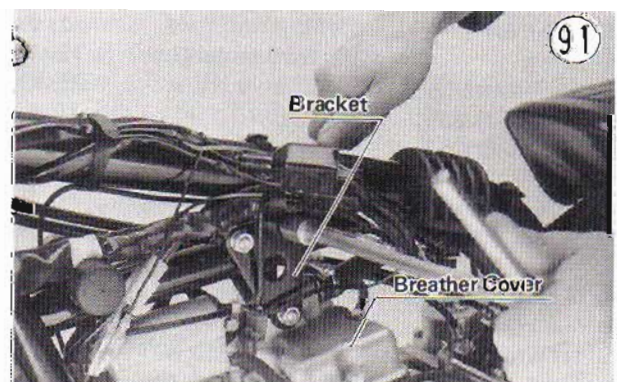

# 30 DISASSEMBLY

## Carburetor

- 1. Mounting Plate
- 2. O Ring
- 3. Linkage Shaft
- 4. Screw
- 5. Lock Washer
- 6. Rubber Cap
- 7. Cap
- 8. Washer
- 9. Spring
- 10. Plunger Shaft
- 11. Plunger
- 12. Gasket
- 13. Cap & Vacuum Piston
- 14. Screw
- 15. Jet Needle
- 16. Screw
- 17. Lock Washer
- 18. Plate
- 19. Gasket
- 20. Main Air Jet
- 21. Slow Air Jet
- 22. Clip
- 23. Fuel Hose
- 24. Clip
- 25. Vacuum Plug
- 26. Washer
- 27. Pilot Screw
- 28. Spring
- 29. Washer
- 30. O ring
- 31. Carburetor Tube
- 32. Clip
- 33. O Ring
- 34. O Ring
- 35. Retainer
- 36. Screw
- 37. Float Valve Seat & Valve Needle
- 38. Pilot Passage Plug
- 39. Pilot Jet
- 40. Slow Jet
- 41. Starter Jet
- 42. Needle Jet
- 43. O Ring
- 44. Main Jet
- 45. Jet Keeper
- 46. Float

- 47. Float Pin
- 48. Drain Plug
- 49. O Ring
- 50. Screw
- 51. Throttle Stop Screw
- 52. Washer
- 53. Plate
- 54. Screw
- 55. Lock Washer
- 56. C Ring
- 57. Clip
- 58. Carburetor Tube
- 59. Clip
- 60. Spring
- 61. Washer
- 62. Pulley Screw
- 63. Nut
- 64. Pulley Spring
- 65. Plastic Washer
- 66. Lock Washer
- 67. Screw
- 68. Pulley Stop Screw
- 69. Nut

- 70. Cable Bracket
- 71. Pulley
- 72. Washer
- 73. C Ring
- 74. Linkage Bar
- 75. Washer
- 76. C Ring
- 77. Bar
- 78. Pusher
- 79. Spring
- 80. Washer
- 81. Bolt
- 82. Balance Adjusting Screw

- 83. Washer
- 84. Washer
- 85. Spring
- 86. Wave Washer
- 87. Screw
- 88. Screw
- 89. Collar
- 90. Lever

- 91. Lever
- 92. Lock Washer
- 93. Nut
- 94. Choke Linkage Rod
- 95. Screw
- 96. Spring
- 97. Float Bowl
- 98. Adjusting Screw Connection

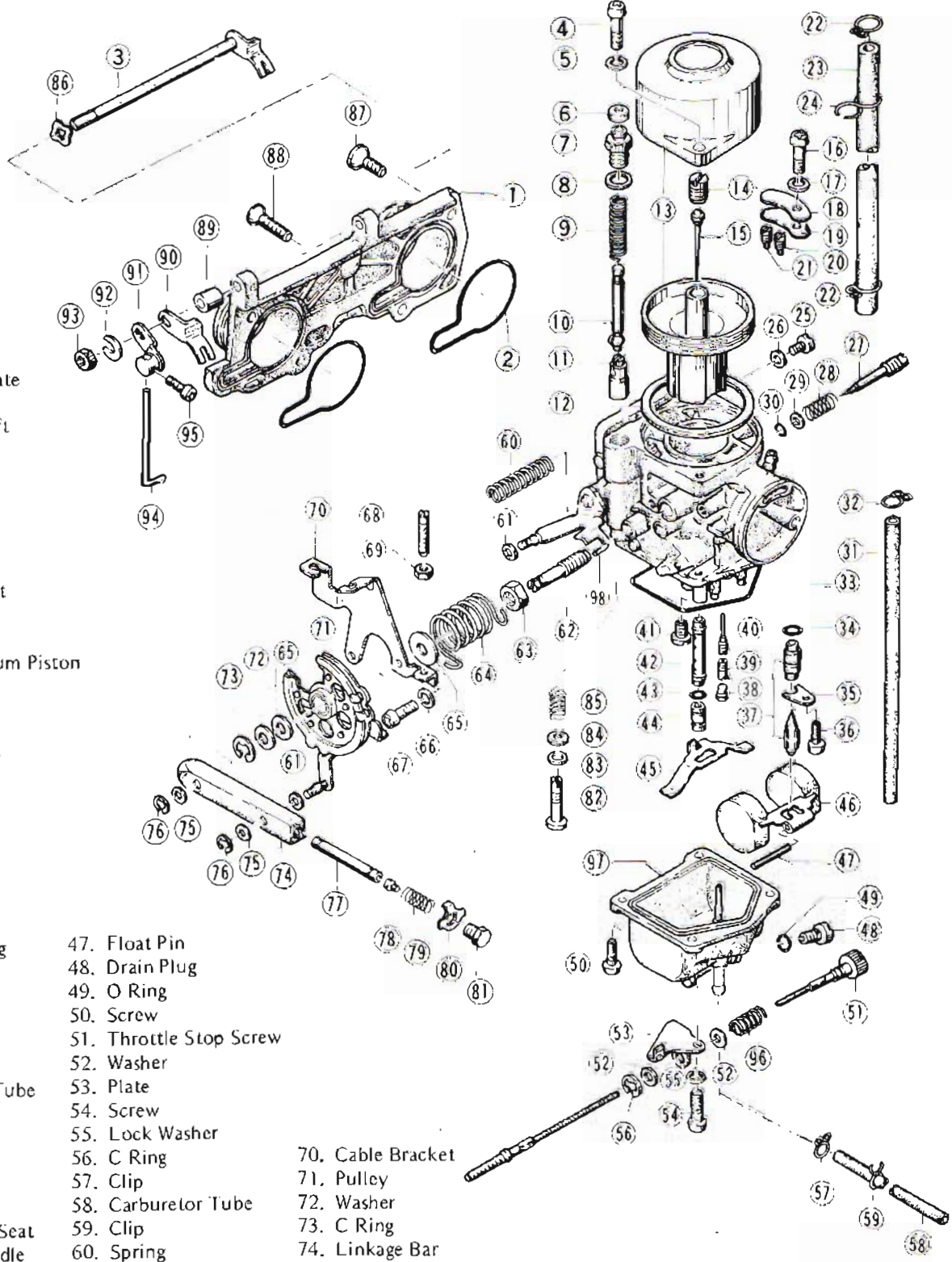

- Remove the breather cover bolts (4), and slip the cover off the cylinder head cover and out of the way.
- Unscrew the tachometer cable from the cylinder head cover.
- Remove the stud nuts (8), and pull off the cylinder head cover. The cover has four O rings.
- Remove the cylinder head cover caps (2).
- Remove the nut from each shaft, and remove the plates (2).

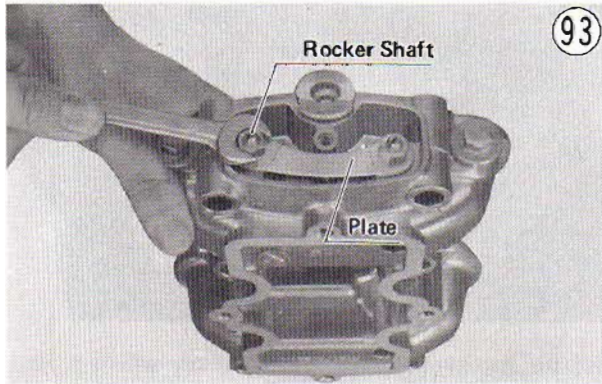

- To remove a rocker arm, wrap a thick piece of cloth around the end of the shaft, and pull the shaft out with pliers.

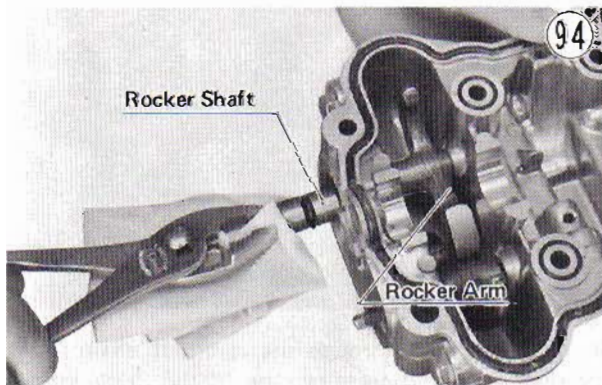

**Installation:**

- Daub a little oil on each shaft O ring, run each shaft into the cover and through its rocker arm. The large contact surface of the rocker arm rides on the cam. Turn each shaft such that the punch mark faces in.

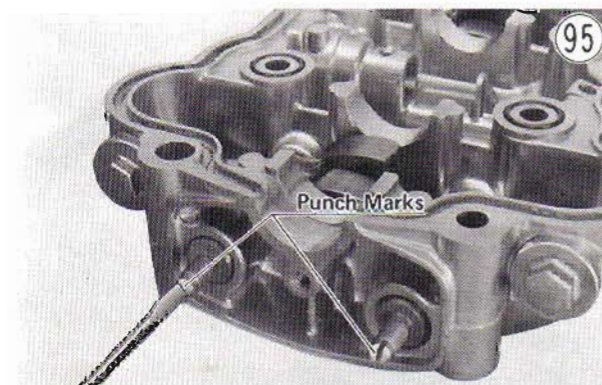

- Replace the plates and each shaft nut.

- Pull the leads off the spark plugs, and remove the spark plugs.
- Remove the tachometer gear from the cover.
- Remove the contact breaker cover, turn the crankshaft such that the timing advancer "T" mark aligns with the timing mark, and then replace the contact breaker cover.
- Apply liquid gasket to the cylinder head cover O ring fitting surface if necessary to hold the O ring to the cover. Check that all O rings (4) are in place.

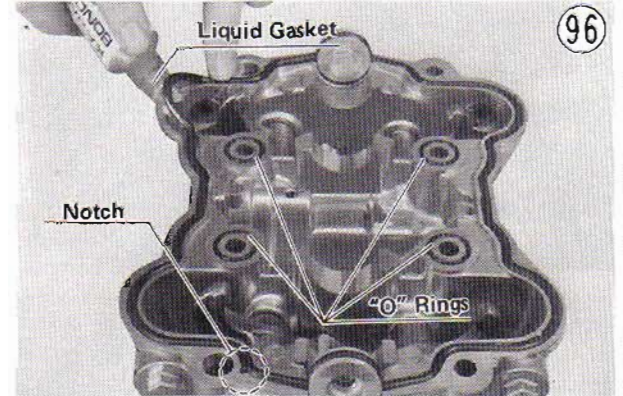

- Place the cylinder head cover on the cylinder head, and replace the nuts (8). Tighten the nuts in the sequence shown in Fig. 97, tightening first each nut to 1.5 kg-m (11 ft-lbs) of torque and then to 2.5 ~ 3.0 kg-m (18 ~ 22 ft-lbs).

**Cylinder Head Cover Tightening Order**

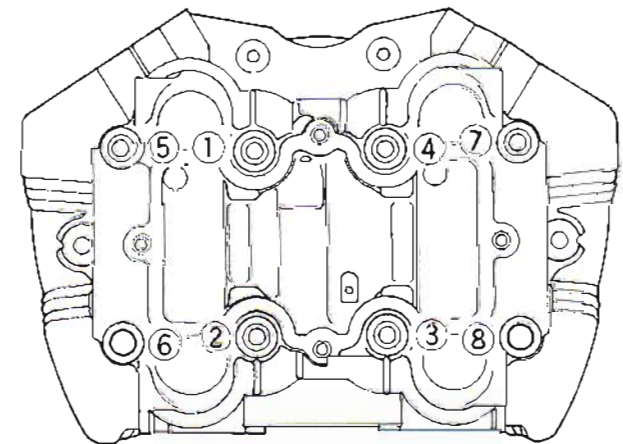

- Replace the cylinder head cover caps (2).
- Apply a small amount of heat durable grease to the tachometer gear, insert the gear, and reconnect the cable to the cylinder head cover.
- Replace the spark plugs, and connect each spark plug lead onto its plug.
- Apply liquid gasket if necessary to the breather cover O ring groove to hold the O ring in place for installation.
- Replace the breather cover tightening its bolts (4) with 1.8 ~ 2.3 kg-m (13 ~ 16.5 ft-lbs) of torque. Each bolt has a flat washer.
- Replace the breather cover bracket. Each bolt has a lock washer.
- Install the fuel tank (Pg. 27).
- Adjust the valve clearance (Pg. 14).

## 32 DISASSEMBLY

### CAMSHAFT

#### Removal:

- Remove the fuel tank (Pg. 27).
- Remove the bracket connecting the breather cover to the frame.

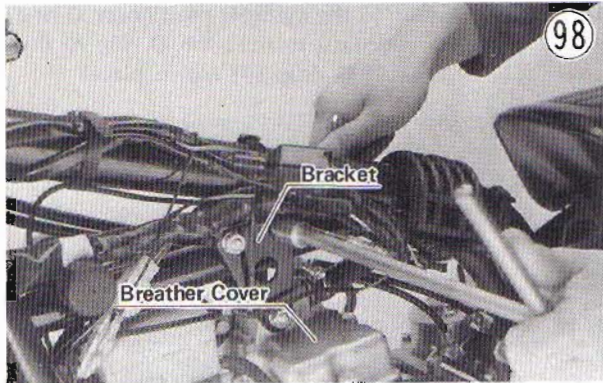

- Remove the breather cover bolts (4), and slip the cover off the cylinder head cover and out of the way.
- Unscrew the tachometer cable from the cylinder head cover.
- Remove the stud nuts, and pull off the cylinder head cover. The cover has four O rings.
- Remove the chain tensioner cap and O ring.
- Remove the chain tensioner screws, and pull out the entire tensioner assembly.

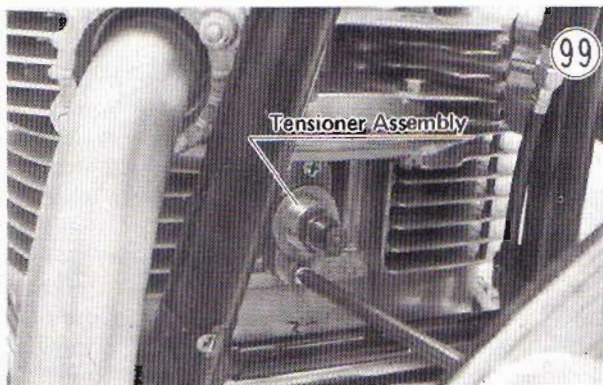

- Remove the contact breaker cover and gasket.
- Remove the camshaft sprocket bolts (2). Use a 17 mm wrench to turn the crankshaft.



- Slide the sprocket off its position on the camshaft, and slip the chain off the sprocket.

- Remove the camshaft and sprocket. Use a screwdriver to keep the chain from falling down into the cylinder block.

#### Installation:

- Place a cylinder head holding plate (special tool) on both sides of the cylinder head, and tighten both in place using the stud nuts (8).

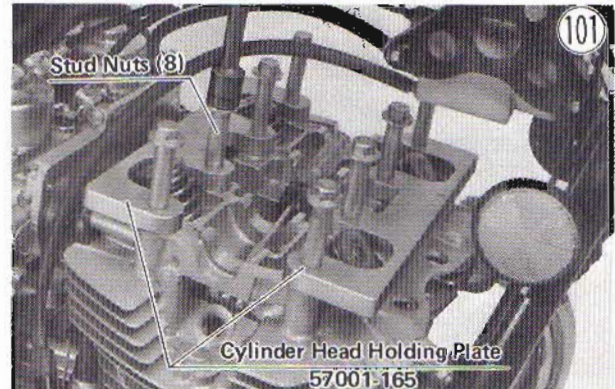

- Set the sprocket on the camshaft near where it fits. The arrowed side of the sprocket faces the right side of the engine.

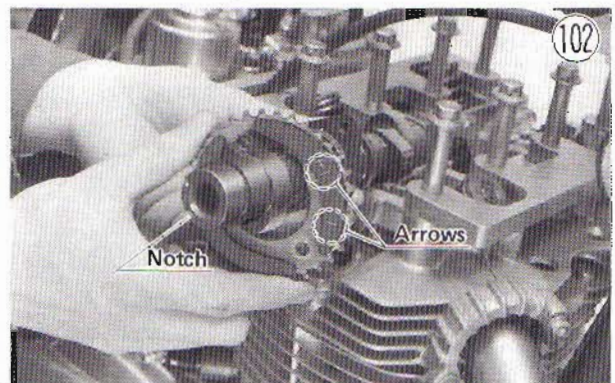

- Run the camshaft through the camshaft chain from the right side of the engine, and fit the chain on the sprocket.
- Using a 17 mm wrench on the crankshaft, turn the engine to where the timing advancer "T" mark (the line adjoining the "T") aligns with the timing mark. Next, turn the crankshaft counterclockwise exactly 90° (¼ turn). Verify crankshaft position by checking that the timing mark is aligned with the timing advancer as shown in Fig. 104.

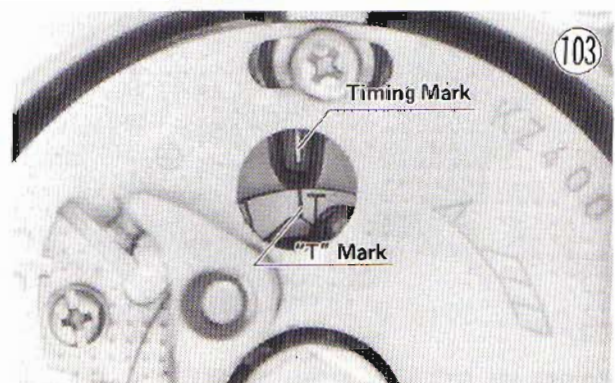

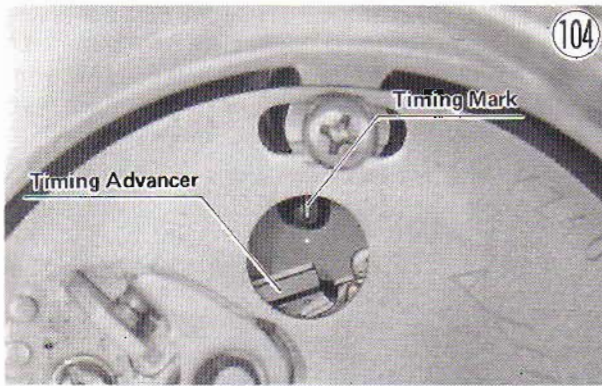

Camshaft Timing

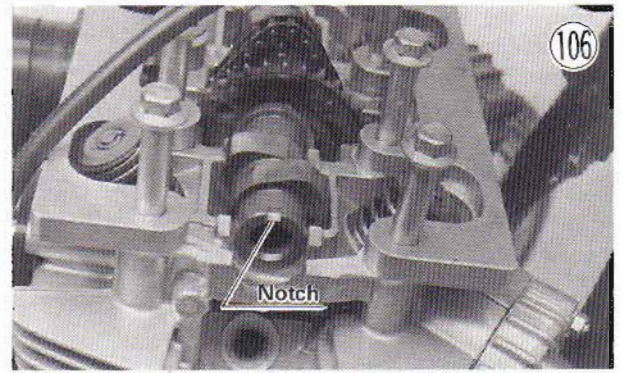

105

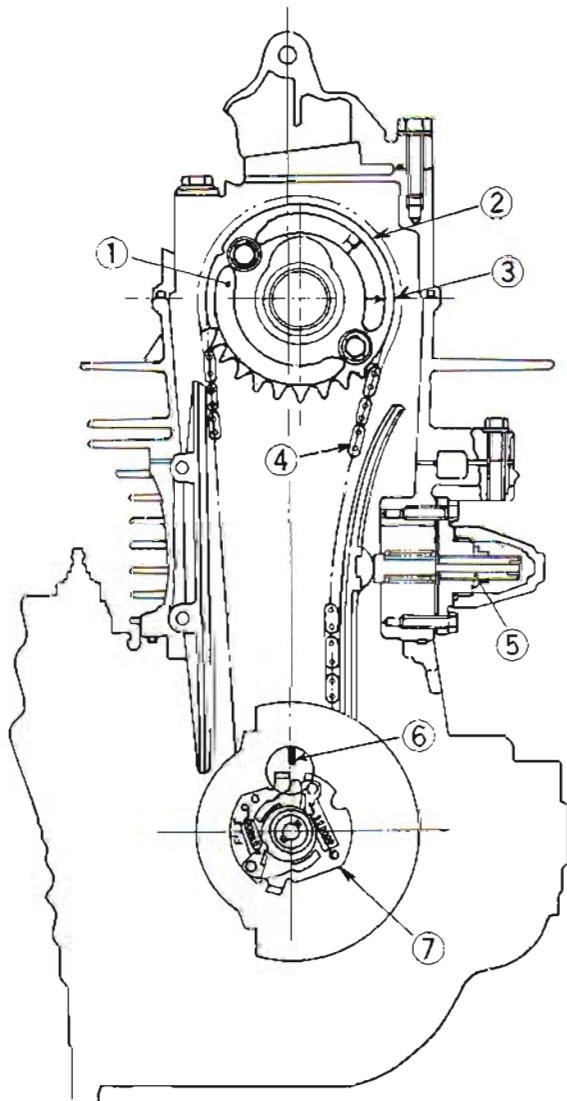

- 1. Camshaft Sprocket
- 2. TDC Mark
- 3. Camshaft Timing Mark
- 4. Camshaft Chain
- 5. Chain Tensioner
- 6. Timing Mark
- 7. Automatic Timing Advancer

•Slip the chain off the sprocket, and then turn the camshaft until the notch on the right end faces directly up.

•Turn the sprocket such that the arrow which has no letter adjoining it points to the front of the engine (points parallel to the cylinder head fitting surface), slip the chain back on the sprocket, and fit the sprocket up into place (the bolt holes will not be aligned at this time).

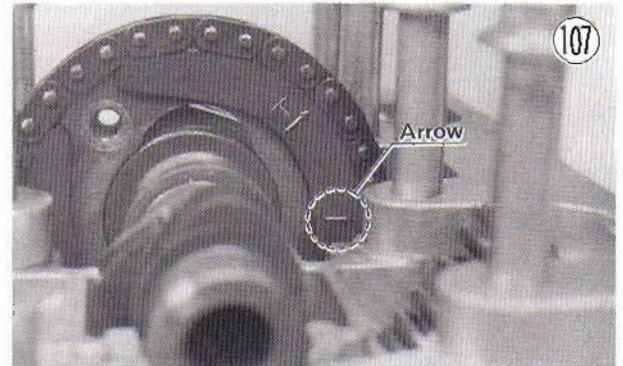

**NOTE:** The camshaft chain must be fitted with the crankshaft, sprocket, and camshaft positioned as just described. Otherwise, the valve timing will be incorrect. The reason for fitting the chain on the sprocket before turning the crankshaft is to avoid kinking the chain on the lower sprocket.

- Turn the crankshaft while holding the camshaft steady such that the bolt holes align.
- Apply a non-permanent locking agent to both sprocket bolts, and replace both bolts tightening them with 1.4 ~ 1.6 kg-m (10 ~ 11.5 ft-lbs) of torque.
- To verify that the valve timing will be correct, turn the crankshaft to where the timing advancer "T" mark aligns with the timing mark, and check that the sprocket arrow which has the "T" adjoining it points to the front of the engine (points parallel to the cylinder head fitting surface).

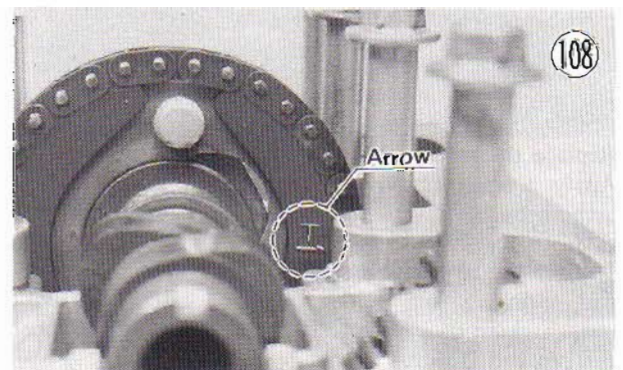

## 34 DISASSEMBLY

- Remove the stud nuts (8), and remove the cylinder head holding plates.
- Remove the tachometer gear and the caps (2) from the cylinder head cover.
- Turn the crankshaft such that the timing advancer "T" mark aligns with the timing mark.
- Apply liquid gasket to the cylinder head cover O ring fitting surface if necessary to hold the O ring to the cylinder head cover. Check that all O rings (4) are in place.

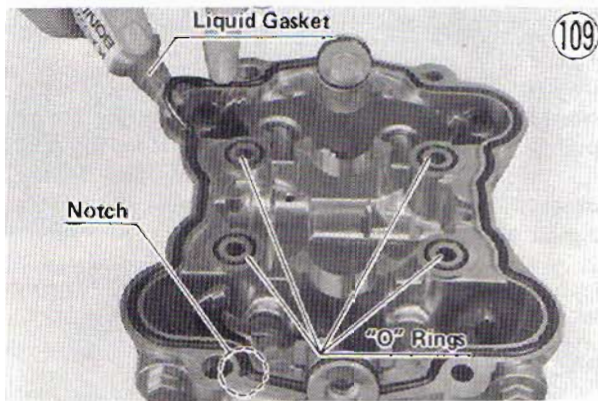

- Place the cylinder head cover on the cylinder head, and replace the nuts (8). Tighten them in the sequence shown in Fig. 110, tightening each nut first to 1.5 kg-m (11 ft-lbs) of torque and then to 2.5~3.0 kg-m (18~22 ft-lbs).

Cylinder Head Cover Tightening Order

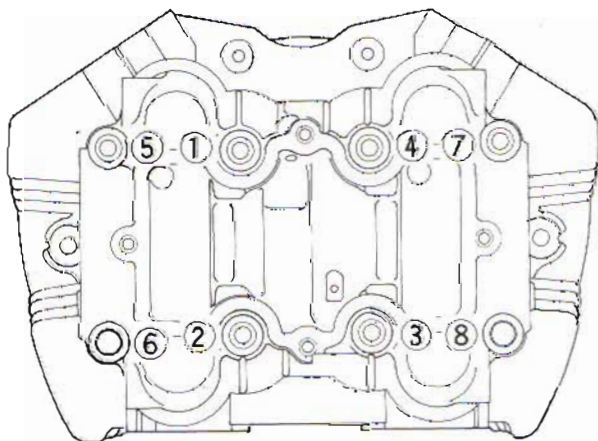

- Replace the cylinder head cover caps.
- Apply a small amount of heat durable grease to the tachometer gear, insert the gear, and reconnect the cable to the cylinder head cover.
- Replace the tensioner assembly. The sequence is push rod, spring, gasket, holder, push rod guide, and lock nut. Tighten its screws, adjust it (Pg. 15), and replace the cap and O ring.

- Apply liquid gasket if necessary to the breather cover O ring groove to hold the O ring in place for installation.
- Replace the breather cover tightening its bolts (4) with 1.8~2.3 kg-m (13~16.5 ft-lbs) of torque. Each bolt has a flat washer.
- Replace the breather cover bracket. Each bolt has a lock washer.
- Install the fuel tank (Pg. 27).
- Replace the contact breaker cover and gasket.

## CYLINDER HEAD

### Removal:

- Remove the camshaft (Pg. 32).
- Remove the muffler collar nuts and lock washers, and slide each muffler collar off its cylinder head studs.
- Remove each rear foot peg to complete muffler removal. Also, remove the muffler gasket from each exhaust port.
- Remove the right and left side covers.
- Loosen the engine intake duct clamp for each carburetor.
- Loosen the clamp that connects each air cleaner duct to its carburetor, and slip it out of place.



- Slip the carburetors down and out of their ducts, pull the carburetors free, and set them on top of the frame.
- Pull the leads off the spark plugs, and remove the spark plugs.
- Disconnect the blue and the red/yellow ignition coil leads.

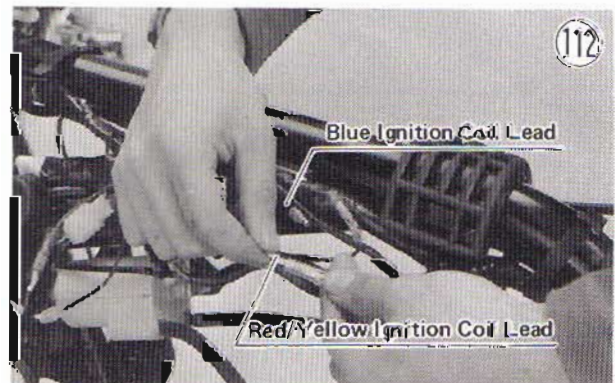

- Remove the ignition coil bracket together with the ignition coil.

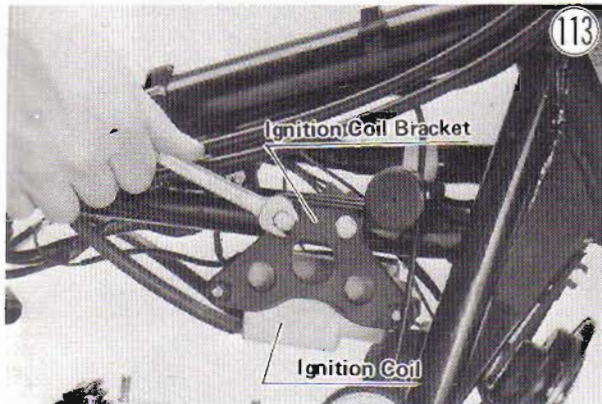

- Remove the cylinder head bolts (4) using special 10 mm and 13 mm sockets and the cylinder head bolt wrench handle (special tools).



- Pull off the cylinder head, and remove the cylinder head gasket. When the cylinder head is part of the way up, insert a screwdriver between the cylinder head and cylinder block through the camshaft chain, and remove the screwdriver which is on top of the cylinder head.

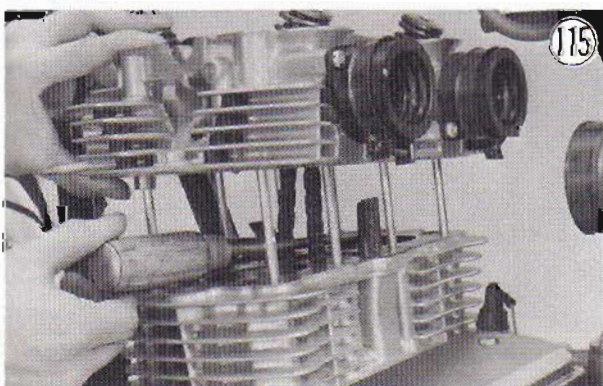

**Installation:**

- Replace the cylinder head gasket, using a new one if it is deteriorated or damaged.
- Check to see that the oval O rings are in place in the gasket.

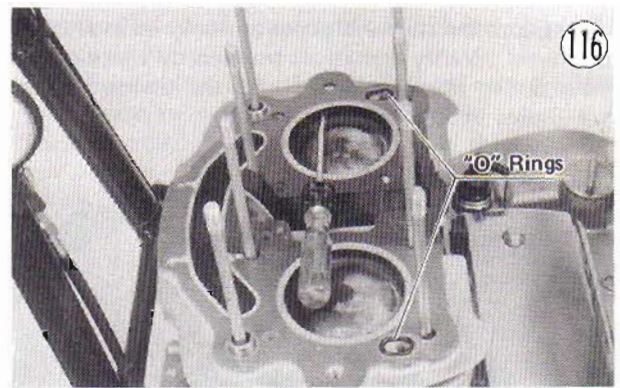

- Fit the cylinder head on the cylinder block while at the same time running the camshaft chain through the cylinder head using a length of cord. Remove the cord, and use a screwdriver resting on the cylinder head to keep the chain from falling.
- Place a cylinder head holding plate (special tool) on both sides of the cylinder head, and tighten both in place using the stud nuts (8).

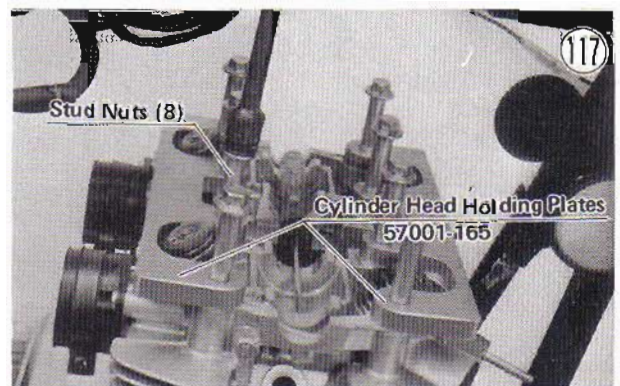

- Set the sprocket on the camshaft near where it fits. The arrowed side of the sprocket faces the right side of the engine.

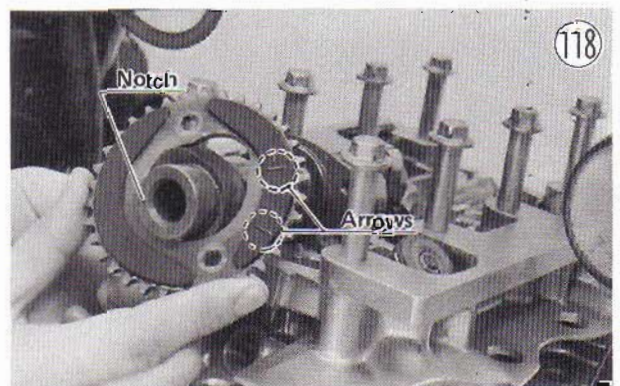

- Run the camshaft through the camshaft chain from the right side of the engine, and fit the chain on the sprocket.
- Using a 17 mm wrench on the crankshaft, turn the engine to where the timing advancer "T" mark (the line adjoining the "T") aligns with the timing mark.

## 36 DISASSEMBLY

Next, turn the crankshaft counterclockwise exactly  $90^\circ$  ( $\frac{1}{4}$  turn). Verify crankshaft position by checking that the timing mark is aligned with the timing advancer as shown in Fig. 120.

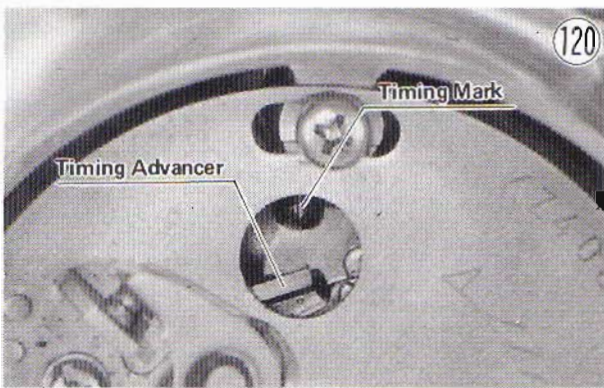
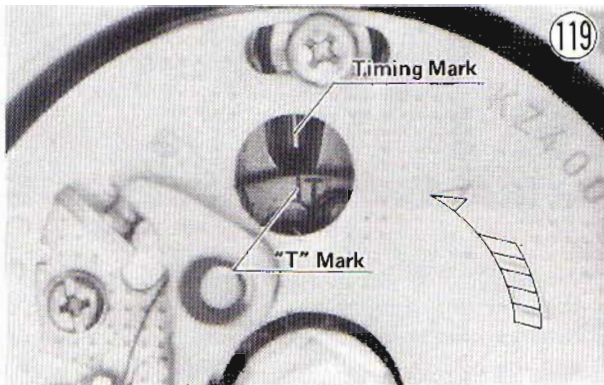

- Slip the chain off the sprocket, and then turn the camshaft until the notch on the right end faces directly up.

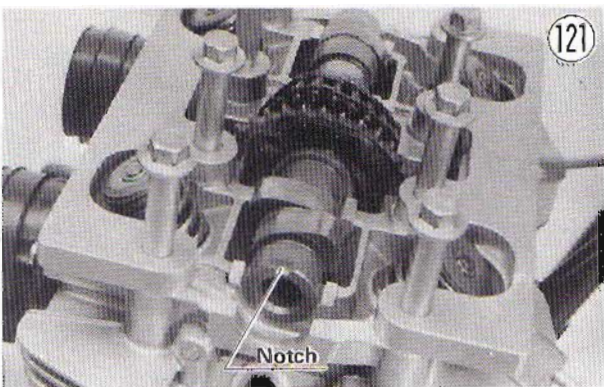

- Turn the sprocket such that the arrow which has no letter adjoining it points to the front of the engine (points parallel to the cylinder head fitting surface), slip the chain back on the sprocket, and fit the sprocket up into place (the bolt holes will not be aligned at this time).

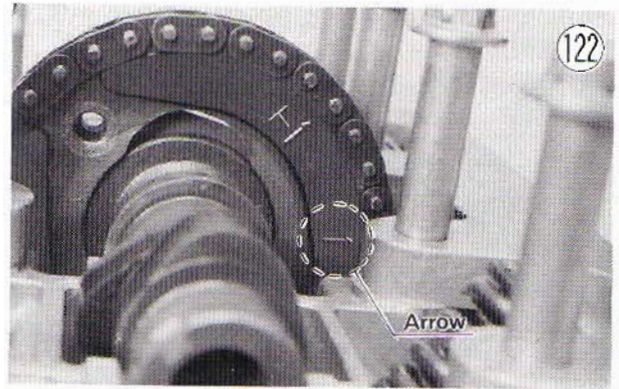

**NOTE:** The camshaft chain must be fitted with the crankshaft, sprocket, and camshaft positioned as just described. Otherwise, the valve timing will be incorrect. The reason for fitting the chain on the sprocket before turning the crankshaft is to avoid kinking the chain on the lower sprocket.

- Turn the crankshaft while holding the camshaft steady such that the bolt holes align.
- Apply a non-permanent locking agent to both sprocket bolts, and replace both bolts tightening them with  $1.4 \sim 1.6 \text{ kg-m}$  ( $10 \sim 11.5 \text{ ft-lbs}$ ) of torque.
- To verify that the valve timing will be correct, turn the the crankshaft to where the timing advancer "T" mark aligns with the timing mark, and check that the sprocket arrow which has the "T" adjoining it points to the front of the engine (points parallel to the cylinder head fitting surface).

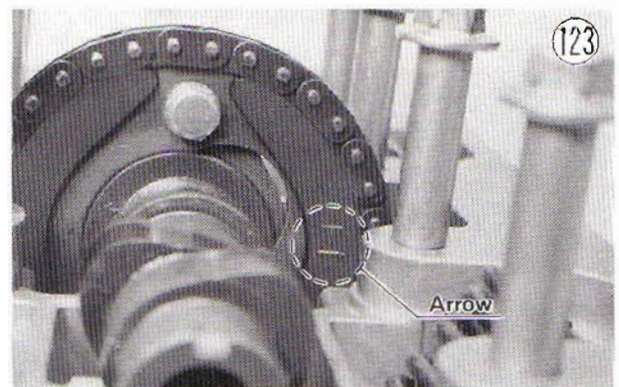

- Remove the stud nuts (8), and remove the cylinder head holding plates.
- Remove the tachometer gear and the caps (2) from the cylinder head cover.
- Turn the crankshaft such that the timing advancer "T" mark aligns with the timing mark.

- Apply liquid gasket to the cylinder head cover O ring fitting surface if necessary to hold the O ring to the cylinder head cover. Check that all O rings (4) are in place.

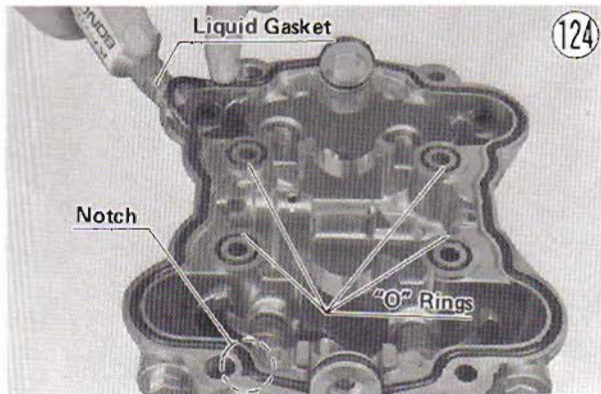

- Place the cylinder head cover on the cylinder head, and replace the nuts (8). Tighten them in the sequence shown in Fig. 125, tightening each nut first to 1.5 kg-m (11 ft-lbs) of torque and then to 2.5 ~ 3.0 kg-m (18 ~ 22 ft-lbs).

#### Cylinder Head & Cylinder Head Cover Tightening Order

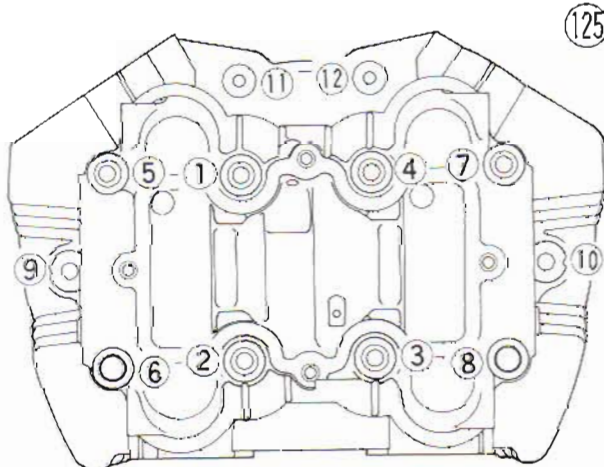

- Replace the cylinder head bolts (4) using special 10 mm and 13 mm sockets (special tools). Tighten in the sequence shown in Fig. 125, tightening the 8 mm bolts with 2.5 ~ 3.0 kg-m (18 ~ 22 ft-lbs) of torque and then the 6 mm bolts with 1.1 ~ 1.3 kg-m (9.5 ~ 11.3 in-lbs).
- Replace the cylinder head cover caps.
- Apply a small amount of heat durable grease to the tachometer gear, insert the gear, and reconnect the cable to the cylinder head cover.
- Replace the tensioner assembly. The sequence is push rod, spring, gasket, holder, push rod guide, and lock nut. Tighten its screws, adjust it (Pg. 15), and replace the cap and O ring.
- Install the ignition coil bracket together with the ignition coil.
- Connect the blue and the red/yellow ignition coil leads.

- Replace the spark plugs, and connect each spark plug lead onto the plug.
- Slip the carburetors back into place the reverse of how they were removed. Have the breather tube routed between the air cleaner ducts. The throttle cables go along the right side of the top tube.
- Once the ducts are all properly fitted on the carburetors, tighten all four clamps.
- Route the carburetor tubes (4) to the rear through their guide.



- Replace the right and left side covers.
- For each muffler, fit the gasket and the end of the muffler into its exhaust port, and attach the muffler to the frame tightening its foot peg nut loosely. A lock washer and flat washer go with the nut.
- Fit each split keeper and collar back into place, and tighten the collar nuts evenly to avoid an exhaust leak. There is a lock washer for each nut.



- Tighten the foot peg bolts securely.
- Apply liquid gasket if necessary to the breather cover O ring groove to hold the O ring in place for installation.
- Replace the breather cover tightening its bolts (4) with 1.8 ~ 2.3 kg-m (13 ~ 16.5 ft-lbs) of torque. Each bolt has a flat washer.
- Replace the breather cover bracket. Each bolt has a lock washer.
- Install the fuel tank (Pg. 27).
- Replace the contact breaker cover and gasket.

#### VALVES, VALVE GUIDES

##### Removal (per valve and valve guide):

- Remove the cylinder head (Pg. 34).
- Using the valve spring compressor assembly (special tool) to press down the valve spring retainer (2), remove the split keeper (1).

### 38 DISASSEMBLY



- Remove the tool, and then remove the spring retainer, outer spring ③, and inner spring ④.
- Push out the valve ⑪ or ⑫.

#### Valve & Valve Guides

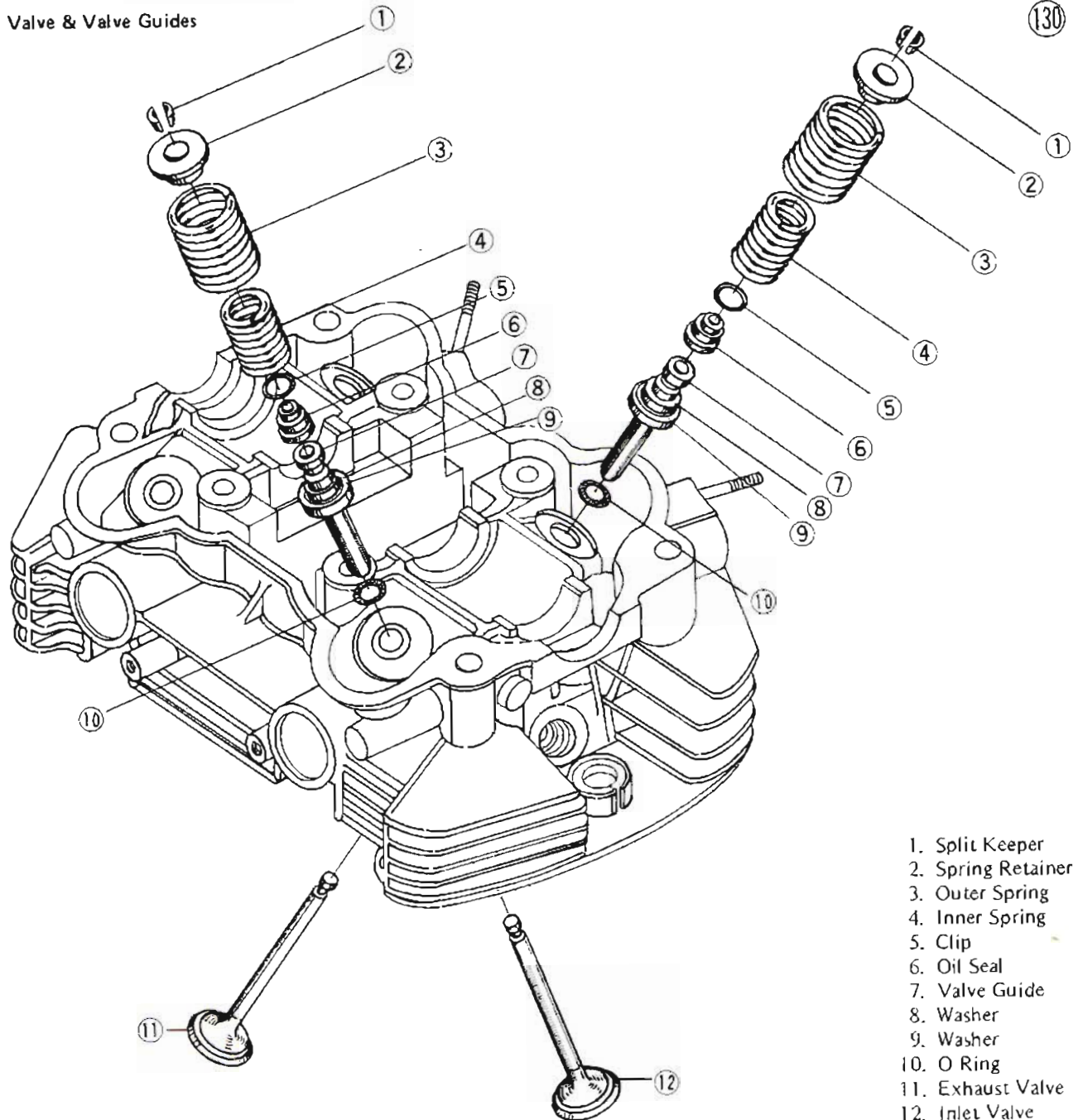

1. Split Keeper
2. Spring Retainer
3. Outer Spring
4. Inner Spring
5. Clip
6. Oil Seal
7. Valve Guide
8. Washer
9. Washer
10. O Ring
11. Exhaust Valve
12. Inlet Valve

- Being careful not to damage the oil seal, remove the clip ⑤ and pull off the oil seal ⑥.

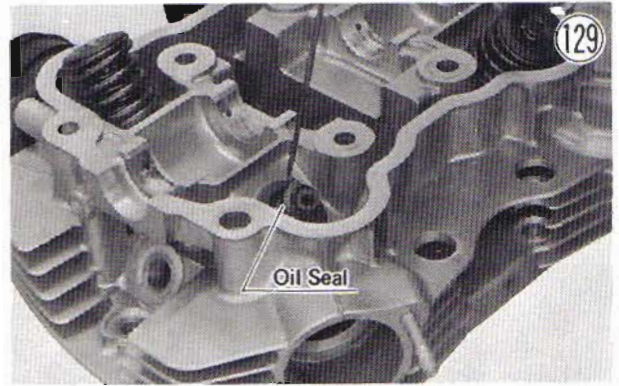

- Remove the washers (8) (9) (2).
- Heat the area around the guide to about 120~150°C (250~300°F), and hammer lightly on the valve guide arbor (special tool) to remove the guide out the top of the head.



#### Installation (per valve and valve guide):

- Apply oil to the valve guide. Replace the O ring for a new one if deteriorated or damaged.
- Heat the area around the valve guide hole to about 120~150°C (250~300°F), and drive the valve guide in from the top of the head using the valve guide arbor (special tool).



- Ream the valve guide with the valve guide reamer (special tool) even if the old guide is re-used.



- Lap the valve so that it will seat properly (Pg. 107).
- Replace the washers (2), push the oil seal into place, and replace its clip.

- Apply a thin coat of heat durable grease to the valve stem, insert the valve, and replace the outer and inner springs. The relatively concentrated portion of each spring should face the cylinder head.

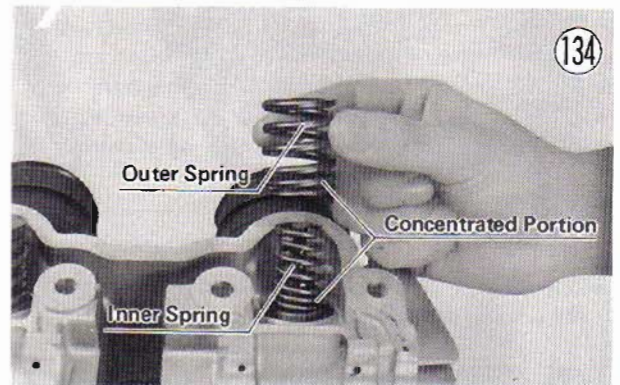

- Replace the valve retainer, press it down with the valve spring compressor assembly, and replace the split keeper.
- Remove the tool.
- Install the cylinder head (Pg. 35).
- Check valve clearance (Pg. 14), and adjust if necessary.

#### CYLINDER BLOCK

##### Removal:

- Remove the cylinder head (Pg. 34).
- Remove the screwdriver, and pull off the cylinder block.

##### Installation:

- Replace any of the cylinder block O rings, cylinder base gasket, or oil passage O rings for a new one if deteriorated or damaged.



- Fit a piston base (special tool) into place at the crankcase opening for each piston, and turn the crankshaft with a 17 mm wrench such that each piston is situated squarely on its piston base.

## 40 DISASSEMBLY

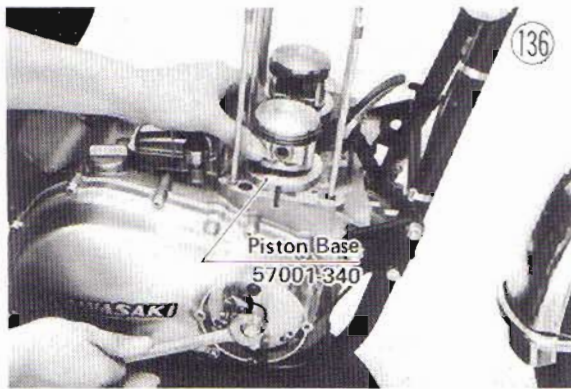

- Compress the piston rings using a piston ring compressor and adapter "A" (special tools) for each piston.

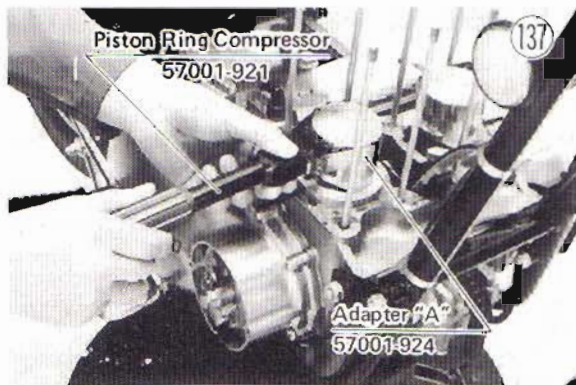

- Pull out the camshaft chain, and let it hang over the side of the crankcase.
- Fit the cylinder block on the crankcase studs, guide the front camshaft chain guide inside the block, and rest the bottom of the cylinders on the piston ring compressors.
- Lift up the camshaft chain, use a screwdriver to keep the chain from falling down into the cylinder block.

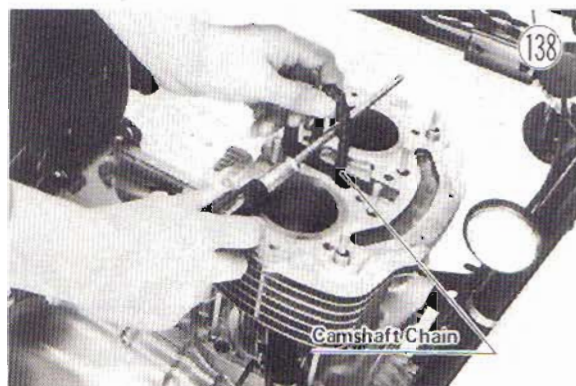

- Work the bottom of each cylinder past the rings, and set the cylinder block in place while removing the special tools.
- Install the cylinder head (Pg. 35).

## PISTON, PISTON RINGS

### Removal:

- Remove the cylinder block (Pg. 39).
- Wrap clean cloth around the base of each piston to secure it in position for removal and so that no parts will fall into the crankcase.
- Remove one of the piston pin snap rings from each piston.



- Remove each piston by pushing its piston pin out the side that the snap ring was removed. Use the piston pin puller and adapter "B" (special tools) if necessary.

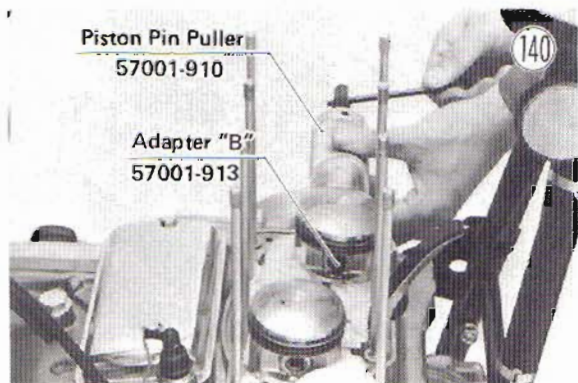

- Remove the piston rings with the piston ring pliers (special tool). To remove a ring by hand, spread the ring opening with both thumbs, and then push up on the opposite side.



**Installation:**

- Install the piston rings so that the correct side (marked "N") faces up (Fig. 142). Don't mix up the top and second rings. The outer edges of the top ring are oblique; the lower outer edge of the second ring is notched. Insert the rings so that the gaps of the top ring and the oil ring face the exhaust side and the gap of the 2nd ring faces the inlet side.

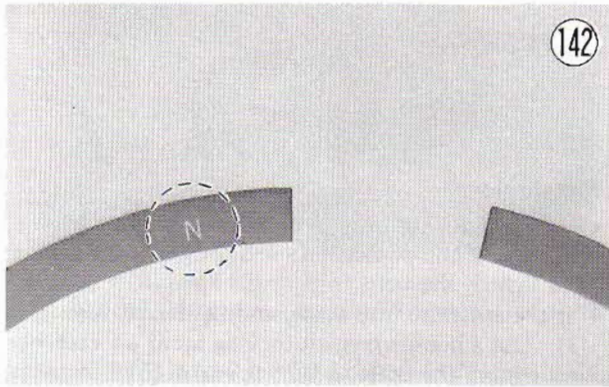

Piston Rings

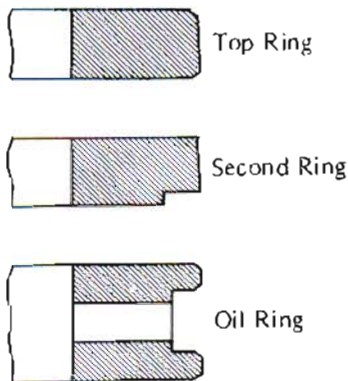

- Apply a little oil to the piston pins, and replace the piston and piston pins. The arrow on the top of each piston must point towards the front.

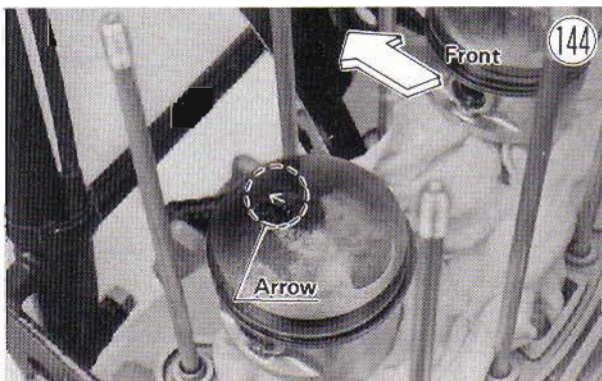

- Fit a new piston pin snap ring into the side of each piston.

- Remove the cloth from under each piston.
- Install the cylinder block (Pg. 39).
- NOTE:** If the piston is replaced with a new one, piston to cylinder clearance changes (Pg. 110). Also, when a new piston or piston pin is installed, check that the piston to pin clearance is 0.0055~0.0135 mm.

To the Dealer: When possible, match parts from stock so that a marked pin is assembled with an "A" piston and an unmarked pin with an unmarked piston. Also, when possible, use a "2" piston with a "2" cylinder bore and an unnumbered piston with an unnumbered cylinder bore.

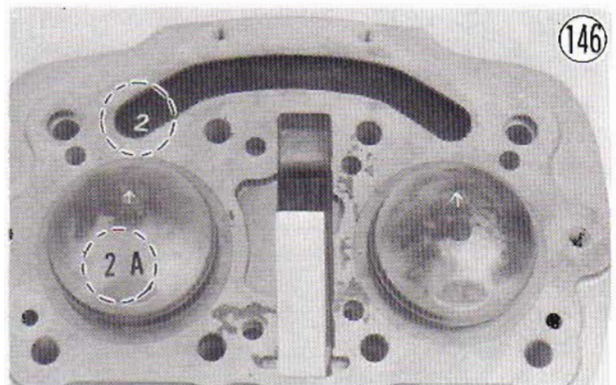

**DYNAMO FIELD COIL**

**Removal:**

- Remove the right side cover, and disconnect the field coil plug from its socket under the voltage regulator.



## 42 DISASSEMBLY

- Take out the shift pedal bolt, and remove the shift pedal.
- Remove the left foot peg bolt, left foot peg, and side stand spring.
- Remove the engine sprocket cover screws (4), and pull the cover free from the crankcase.
- Remove the dynamo and starter motor wiring guide.



- Remove the starter motor cover and gasket.
- Remove the dynamo cover screws (8), and pull off the dynamo cover.



- Disconnect the oil pressure indicator switch lead and the neutral indicator switch lead.
- Remove the starter motor chain guide and sprocket guide.

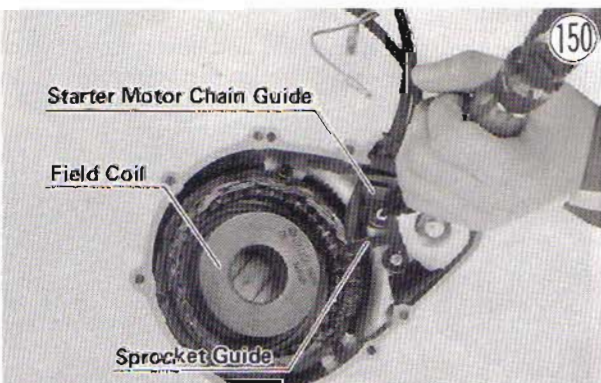

- Remove the armature Allen bolts (3), and pull out the armature.

- Remove the field coil mounting Allen bolts (3), and remove the field coil.



### Installation:

- Set the field coil into place, and tighten its Allen bolts (3). Use a non-permanent locking agent on each bolt, and tighten the bolts to 0.7~0.8 kg-m (61~69 in-lbs).
- Fit the armature into place, and tighten its Allen bolts (3). Use a non-permanent locking agent on each bolt, and tighten the bolts to 0.7~0.8 kg-m (61~69 in-lbs).
- Fit the wiring into the dynamo cover grommets, and push the grommets back into the cover.
- Apply a non-permanent locking agent to the screws, and replace the starter motor chain guide and sprocket guide. The sprocket guide bends out for contact with the sprocket.
- Connect the oil pressure indicator switch lead and neutral indicator switch lead.
- Replace the dynamo cover, and tighten its screws (8).
- Replace the starter motor cover and gasket.
- Fit first the starter motor lead and then the dynamo wiring into the wiring guide, and screw the guide back on the crankcase.
- Replace the engine sprocket cover using the shift shaft oil seal guide (special tool) to protect the cover oil seal, and tighten its screws. The wiring is routed in front of the upper mounting bolt spacer.

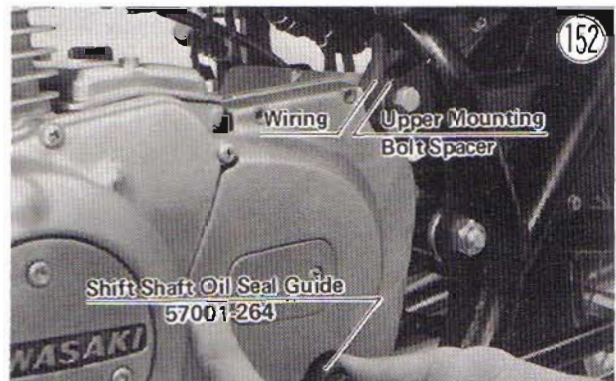

- Fit the side stand spring into place, and then secure the left foot peg with its bolt.
- Replace the shift pedal so that its end matches the level of the dynamo cover lower right screw, and tighten its bolt.
- Reconnect the plug to its socket under the voltage regulator.
- Replace the right side cover.

## DYNAMO ARMATURE

## Removal:

- Remove the right side cover, and disconnect the armature plug from its socket under the voltage regulator.



- Take out the shift pedal bolt, and remove the shift pedal.
- Remove the left foot peg bolt, left foot peg, and side stand spring.
- Remove the engine sprocket cover screws (4), and pull the cover free from the crankcase.
- Remove the dynamo and starter motor wiring guide.



- Remove the dynamo cover screws (8), and pull off the dynamo cover.



- Remove the starter motor chain guide and sprocket guide.

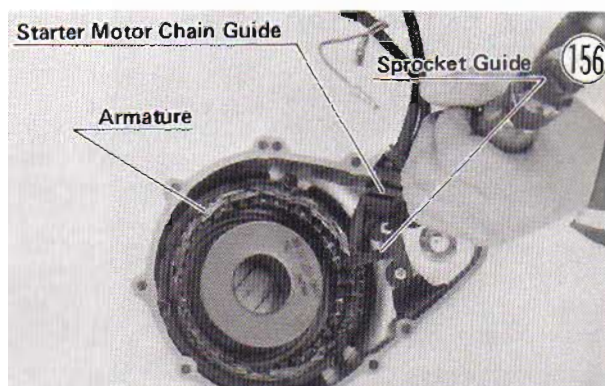

- Remove the armature Allen bolts (3), and pull out the armature.

## Installation:

- Fit the armature into place, and tighten its Allen bolts. Use a non-permanent locking agent on each bolt, and tighten the bolts to 0.7 ~ 0.8 kg-m (61 ~ 69 in-lbs).
- Fit the wiring into its dynamo cover grommets, and press the grommets back into the cover.
- Apply a non-permanent locking agent to the screws, and replace the starter motor chain guide and sprocket guide. The sprocket guide bends out for contact with the sprocket.
- Replace the dynamo cover, and tighten its screws (8).
- Fit first the starter motor lead and then the dynamo wiring into the wiring guide, and screw the guide back on the crankcase.
- Replace the engine sprocket cover using the shift shaft oil seal guide (special tool) to protect the cover oil seal, and tighten its screws. The wiring is routed in front of the upper mounting bolt spacer.

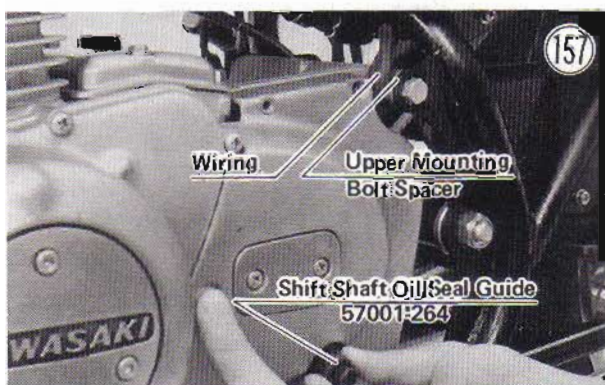

- Fit the side stand spring into place, and then secure the left foot peg with its bolt.
- Replace the shift pedal so that its end matches the level of the dynamo cover lower right screw, and tighten its bolt.
- Reconnect the plug to its socket under the voltage regulator.
- Replace the right side cover.

## 44 DISASSEMBLY

### DYNAMO ROTOR, STARTER MOTOR CLUTCH

#### Removal:

- Take out the shift pedal bolt, and remove the shift pedal.
- Remove the left foot peg bolt, left foot peg, and side stand spring.
- Remove the engine sprocket cover screws (4), and pull the cover free from the crankcase.
- Remove the dynamo cover screws (8), and pull off the dynamo cover and gasket.

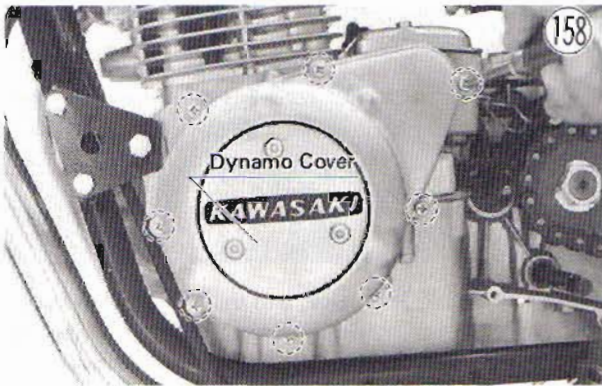

- Hold the dynamo rotor steady with the dynamo rotor holder (special tool), and remove the rotor bolt. The bolt must be turned clockwise for removal.

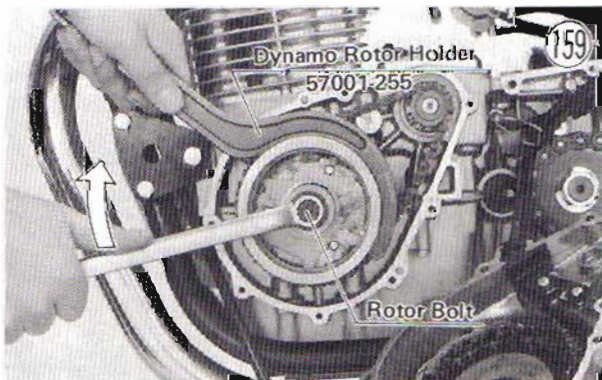

- Using the special tool to hold the rotor steady, remove the rotor and starter motor clutch assembly with the dynamo rotor puller (special tool). There is a thrust washer at the rear of the rotor.



#### Installation:

- Apply a small amount of heat durable grease to the thrust washer, clean off any oil or dirt that may be on the crankshaft taper or rotor hub, and replace it to the rear of the rotor. Place the assembly back on the crankshaft.
- Apply a non-permanent locking agent to the rotor bolt threads, and then tighten the bolt to 6.5~7.0 kg-m (4/~51 ft-lbs) of torque while holding the dynamo rotor steady with the dynamo rotor holder (special tool).
- Replace the dynamo cover, gasket, and screws (8).
- Replace the engine sprocket cover using the shift shaft oil seal guide (special tool) to protect the cover oil seal, and tighten its screws.

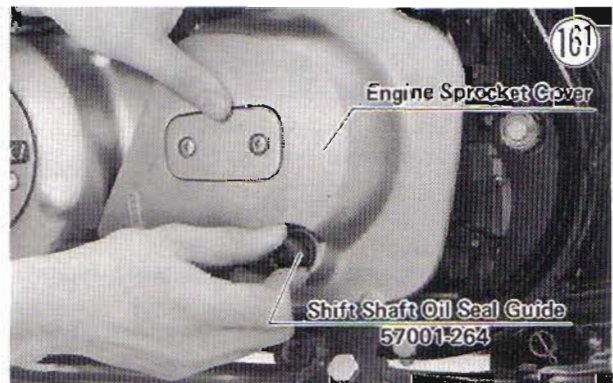

- Fit the side stand spring into place, and then secure the left foot peg with its bolt.
- Replace the shift pedal so that its end matches the level of the dynamo cover lower right screw, and tighten its bolt.

#### Disassembly:

- Remove the rollers, springs, and spring caps (3 ea) from the starter motor clutch.

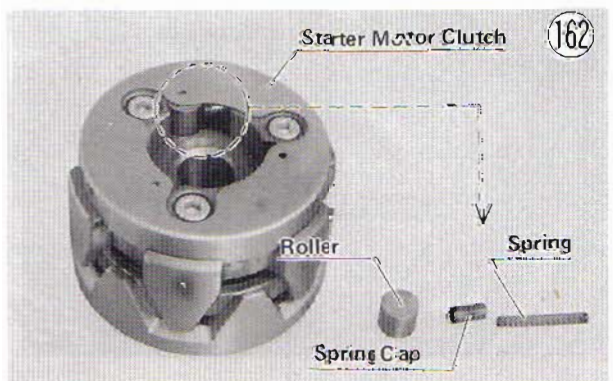

- Wrap the rotor with cloth, and clamp it in a vise.

Remove the Allen bolts to separate the rotor and starter motor clutch.

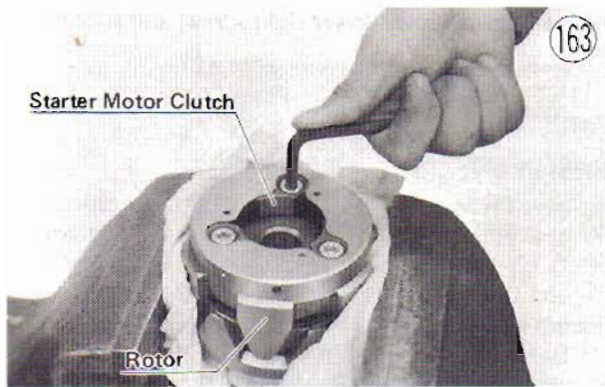

#### Assembly Note:

- Apply a non-permanent locking agent to the Allen bolts, and tighten the bolts with 3.3 ~ 3.7 kg-m (24 ~ 27 ft-lbs) of torque.

### STARTER MOTOR CHAIN & SPROCKETS

#### Removal:

- Remove the dynamo rotor and starter motor clutch (Pg. 44).
- Pull off the starter motor chain and sprockets.

### STARTER MOTOR

#### Removal:

- Take out the shift pedal bolt, and remove the shift pedal.
- Remove the left foot peg bolt, left foot peg, and side stand spring.
- Remove the engine sprocket cover screws (4), and pull the cover free from the crankcase.
- Remove the dynamo cover screws (8), and pull off the dynamo cover and gasket.



- Remove the starter motor cover and gasket.
- Remove the starter motor terminal nut and washer, and remove the lead from the motor.

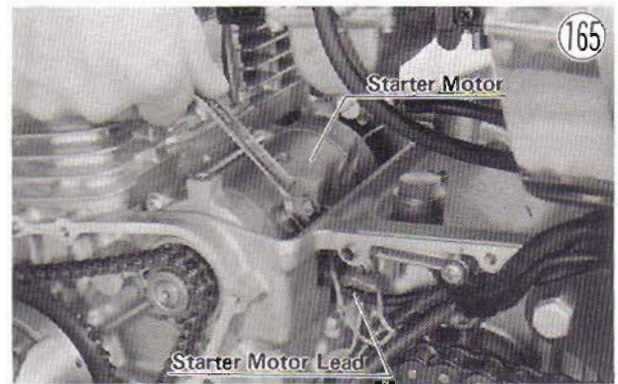

- Using a 10 mm T wrench with a pivoted socket, remove the starter motor retaining bolts (2).

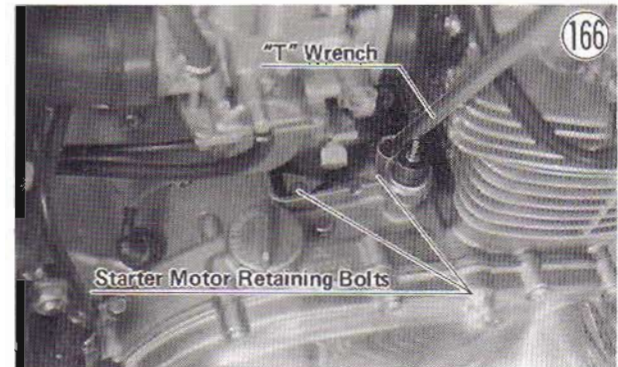

- Tap lightly on the starter motor body as shown in Fig. 167 to free the motor, and then pull it out.



**CAUTION:** Do not tap on the starter motor shaft. Tapping on the shaft may damage the motor.

#### Installation:

- Daub a little oil on the O ring.

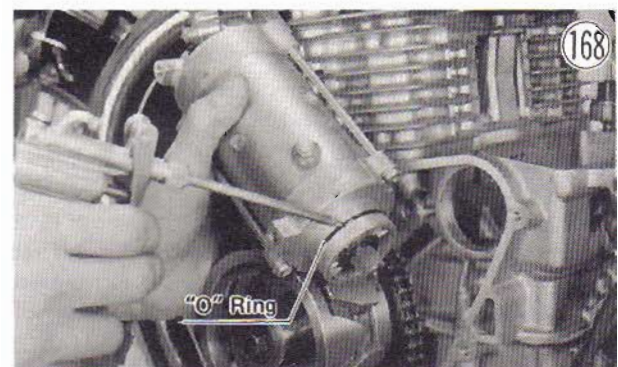

## 46 DISASSEMBLY

- Place the starter motor back into position fitting the shaft through the sprocket.
- Reconnect the motor lead onto the terminal. A lock washer goes with the nut.
- Apply a non-permanent locking agent to the starter motor retaining bolts, and tighten the bolts. Each bolt has a flat washer.
- Replace the starter motor cover and gasket.
- Replace the dynamo cover, gasket, and screws (8).
- Replace the engine sprocket cover using the shift shaft oil seal guide (special tool) to protect the cover oil seal, and tighten its screws.



- Fit the side stand spring into place, and then secure the left foot peg with its bolt.
- Replace the shift pedal so that its end matches the level of the dynamo cover lower right screw, and tighten its bolt.

### Disassembly:

- Remove the starter motor shaft circlip (1) and shims (2).
- Remove the screws (5) (2), and remove the end covers (4) (2) (2), shaft (9), and gears (10) (2). The grease seal (8) and O ring (3) may be removed with a hook.
- Remove the end plate (12), gaskets (11) (13), and armature (17) from the shaft side.
- Remove the screw which connects the brush lead (20) to the field coil lead (15), and remove the brush plate (19). The screw has a lock washer. There is an O ring (22) at the brush side of the housing.

**NOTE:** The yoke assembly (14) is not meant to be disassembled.

### Assembly Notes:

1. Replace the grease seal for a new one if it was removed, and replace any O rings that are deteriorated or damaged for new ones.

### Starter Motor

(170)

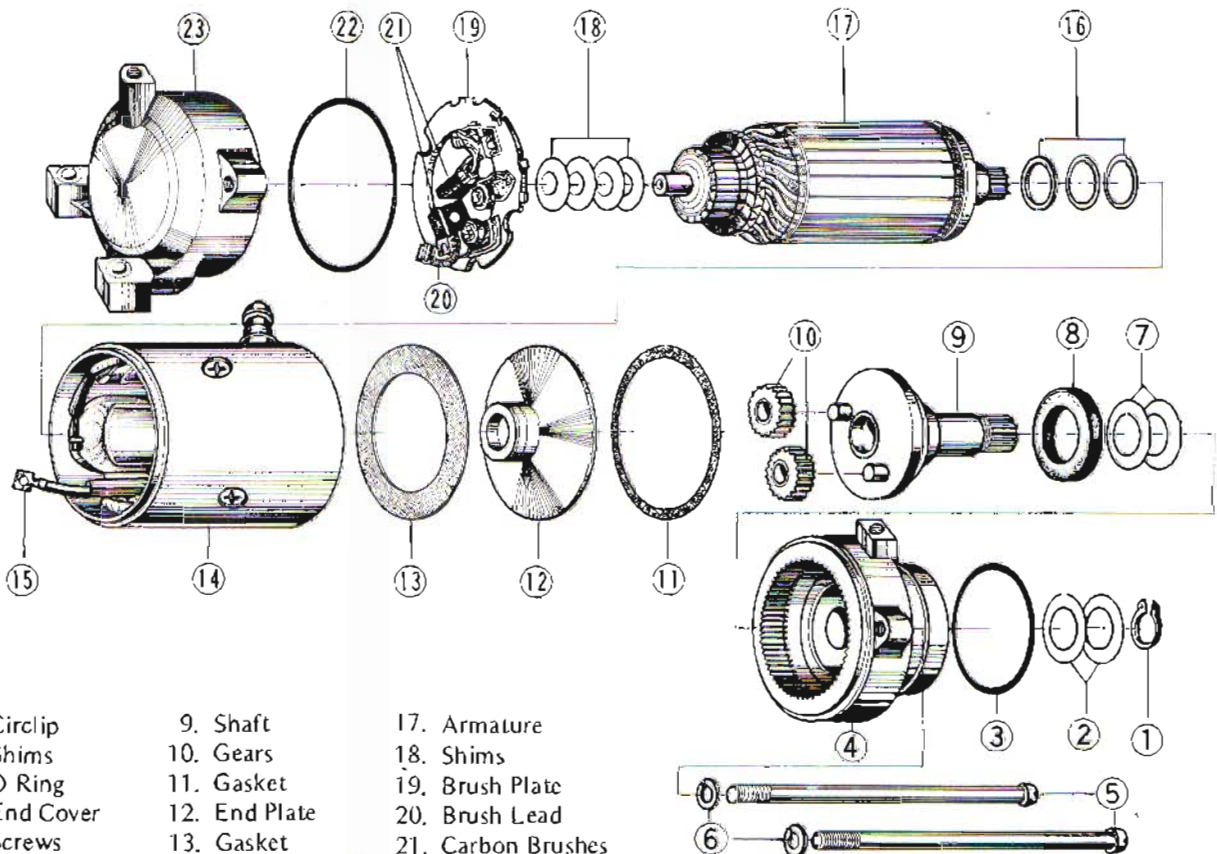

- |                 |                     |                    |
|-----------------|---------------------|--------------------|
| 1. Circlip      | 9. Shaft            | 17. Armature       |
| 2. Shims        | 10. Gears           | 18. Shims          |
| 3. O Ring       | 11. Gasket          | 19. Brush Plate    |
| 4. End Cover    | 12. End Plate       | 20. Brush Lead     |
| 5. Screws       | 13. Gasket          | 21. Carbon Brushes |
| 6. Lock Washers | 14. Yoke Assembly   | 22. O Ring         |
| 7. Shims        | 15. Field Coil Lead | 23. End Cover      |
| 8. Grease Seal  | 16. Shims           |                    |

- Align the notch on the end plate with the nub on the housing, and align the line on each end cover with its line on the housing.

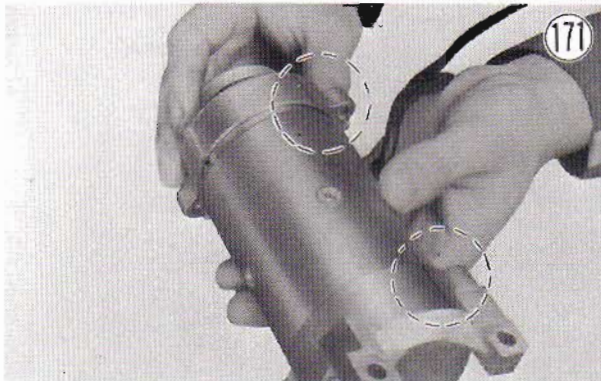

## IGNITION COIL

### Removal:

- Remove the fuel tank (Pg. 27).
- Pull off the lead from each spark plug.
- Disconnect the blue and the red/yellow ignition coil leads.
- Remove the bolts (2) that connect the ignition coil to the frame, and remove the ignition coil.



### Installation Note:

- Use only the Kawasaki ignition coil bolts to mount the ignition coil. Bolts of a different composition may adversely affect ignition coil performance.

## CONTACT BREAKER

### Removal:

- Remove the contact breaker cover and gasket.
- Remove the contact breaker base screw. The screw has a flat and a lock washer.

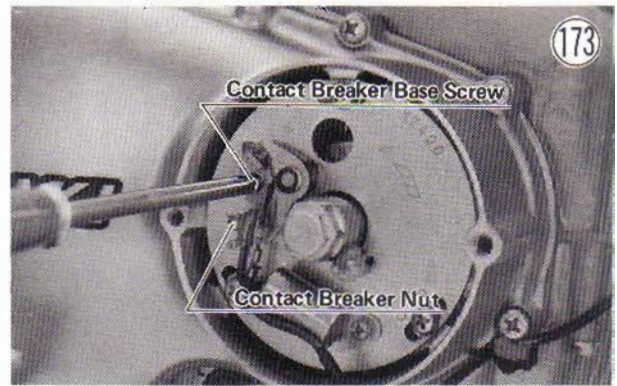

- Loosen the contact breaker nut, and remove the two leads.

### Installation Notes:

- The sequence on the contact breaker bolt is bolt head, contact breaker lead, spring, large insulator, small insulator (in contact breaker hole), large insulator, condenser lead, flat washer, lock washer, and nut.
- After installation, adjust the ignition timing (Pg. 12).

## CONDENSER

### Removal:

- Remove the contact breaker cover and gasket.
- Remove the condenser screw. The screw has a lock washer.

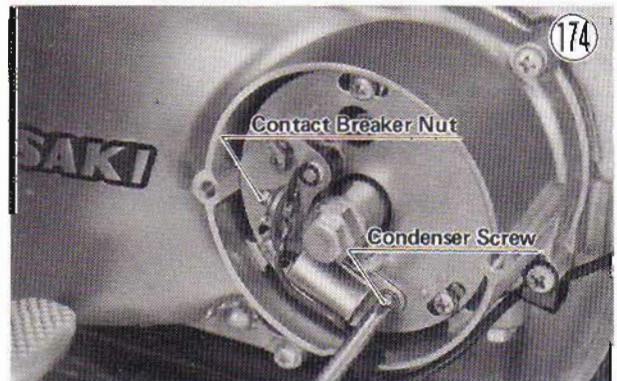

- Loosen the contact breaker nut, and remove the condenser lead to complete condenser removal.

### Installation Note:

- The sequence on the contact breaker bolt is bolt head, contact breaker lead, spring, large insulator, small insulator (in contact breaker hole), large insulator, condenser lead, flat washer, lock washer, and nut.

## TIMING ADVANCER

### Removal:

- Remove the contact breaker cover and gasket.

## 48 DISASSEMBLY

- Take out the contact breaker plate screws (3), and remove the plate.

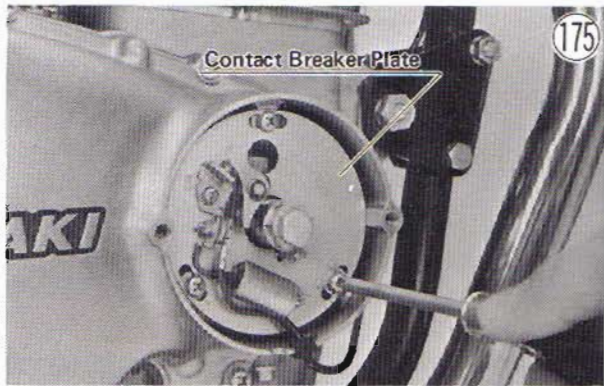

- With one wrench on the crankshaft rotation nut to keep the shaft from turning, remove the bolt, and take off the timing advancer.

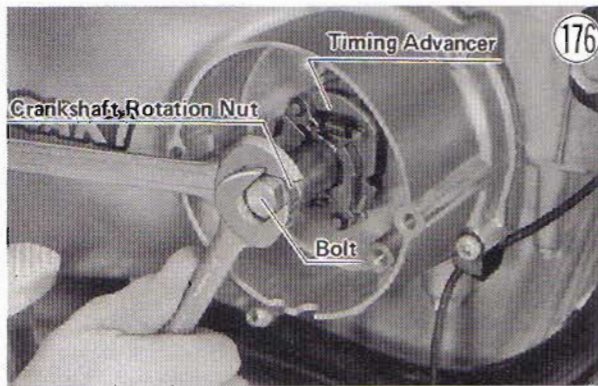

### Installation:

- Fit the timing advancer onto the crankshaft matching its notch with the pin in the end of the crankshaft, and replace the crankshaft rotation nut and the bolt. Tighten the bolt with 2.3~2.7 kg-m (16.5~19.5 ft-lbs) of torque.
- Replace the contact breaker plate, and tighten its screws loosely.
- Adjust the ignition timing (Pg. 12).

### Disassembly:

- Pull off the cam.

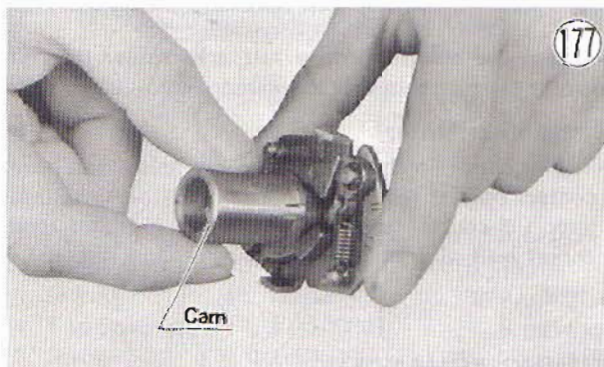

- Remove the two C rings, washers, and weights.
- Remove the thrust washer from each weight shaft.

### Assembly Note:

- When installing the Cam, align the mark on the cam with the notch on the advancer body.

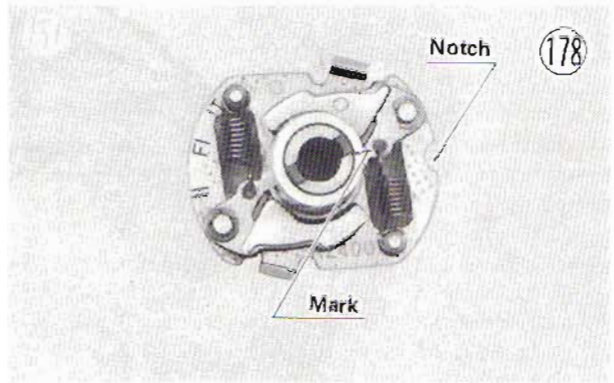

## CLUTCH, PRIMARY CHAIN

### Removal:

- With the motorcycle on its center stand, place an oil pan beneath the engine, and remove the engine oil drain plug and oil filter to drain out the oil.
- Undo the right foot peg bolt, and remove the foot peg.
- Mark the position of the kickstarter pedal so that it can later be replaced on the kick shaft in the same position.
- Take out the kickstarter pedal bolt, and remove the kickstarter pedal.
- Remove the contact breaker cover and gasket.
- Remove the contact breaker plate screws (3), and remove the plate.
- Remove the timing advancer bolt, and pull off the timing advancer.
- Remove the screws (12), and pull off the engine cover and gasket.
- Remove the clutch spring bolts (15), washers (14), and springs (13) (4 ea).
- Pull off the spring plate (12), pull out the spring plate pusher (11), and tilt the motorcycle so that the steel ball (10) will fall out.

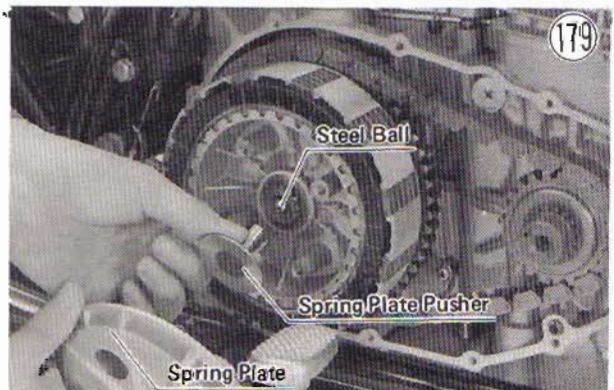

Clutch Construction

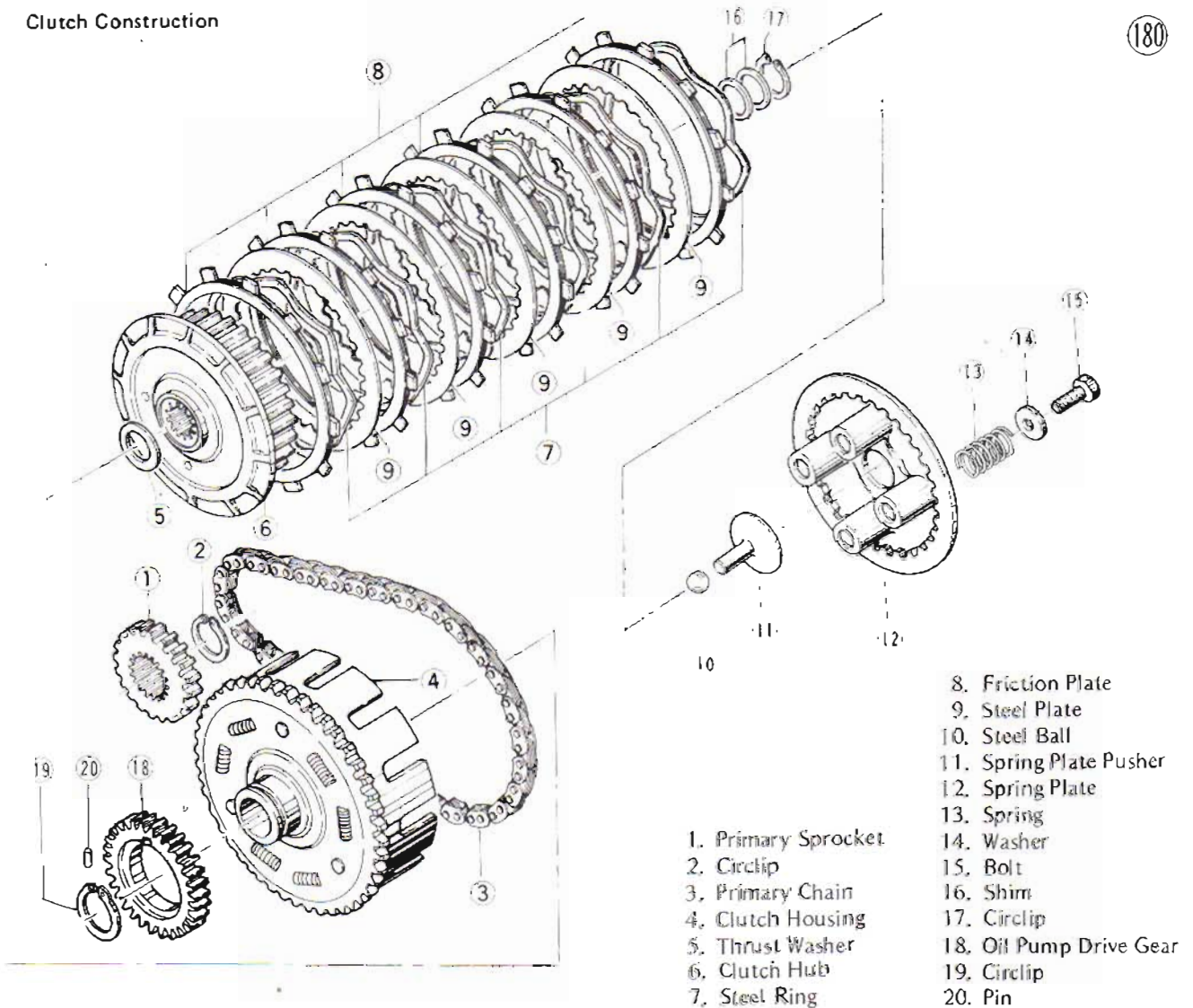

- Remove the clutch hub circlip 17 and shim(s) 16.
- Remove the friction plates 8 (6), steel plates 9 (5), steel rings 7 (6), and clutch hub 6. There is a thrust washer 5 at the rear of the clutch hub.
- Remove the primary sprocket circlip 2.
- Pull off the clutch housing 4, primary sprocket 1, and primary chain 3 together.
- To remove the oil pump drive gear 18 and pin 20, remove the circlip 19, pull off the gear, and pull out the pin.

Installation:

- If the oil pump drive gear was removed, replace its pin, fit on the gear, and replace the circlip. The protruding side of the hub faces the housing.

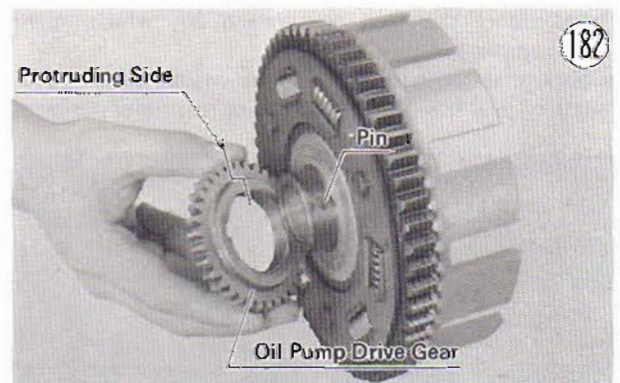

- Fit the primary chain on the clutch housing and primary sprocket, and fit the assembly into place. The protruding side of the primary sprocket faces out. Turn

## 50 DISASSEMBLY

the oil pump gear by hand if necessary so that it meshes with the oil pump drive gear.

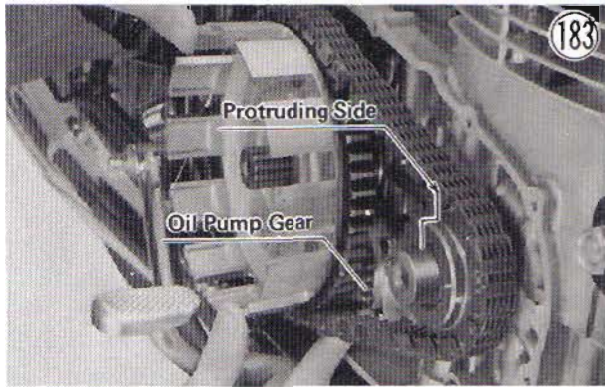

- Replace the primary sprocket circlip.
- Replace the thrust washer (thick) and the clutch hub.
- Replace the shim(s) and clutch hub circlip. The shim(s) should take up all the play between the hub and circlip. If not, add more shim(s).
- Replace the friction plates (6), steel rings (6), and steel plates (5). The sequence is friction plate, steel ring, steel plate, friction plate finishing with a steel ring.
- Insert the steel ball and spring plate pusher.
- Replace the spring plate aligning the raised points on the plate with the punch marks on the hub.

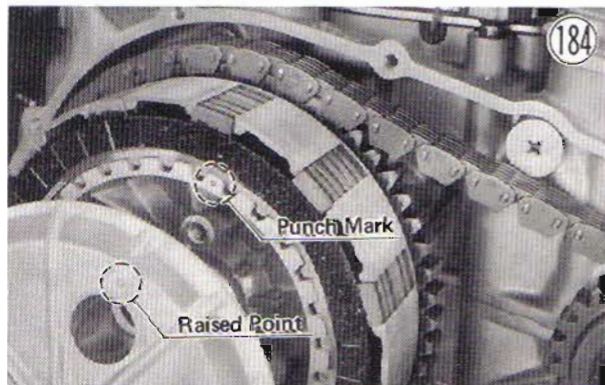

- Replace the spring bolts (4), each with its washer and spring. Tighten them evenly in a cross pattern by hand rather than use compressed air, which might make spring pressure uneven.
- Check that the wire band in the engine cover crankshaft oil seal has not slipped out of its proper position.

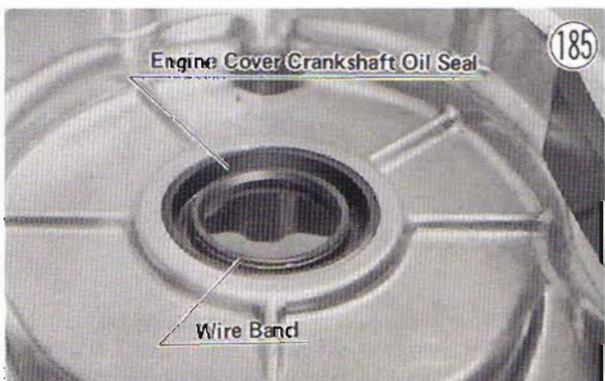

- Using a new engine cover gasket, fit the engine cover onto the crankcase. Use the kick shaft oil seal guide (special tool) to protect the kick shaft oil seal. Tighten the screws (12) firmly. Be sure to include the contact breaker lead clamp with its engine cover screw.



- Fit the timing advancer onto the crankshaft matching its notch with the pin on the end of the crankshaft, and tighten its bolt with 2.3 ~ 2.7 kg-m (16.5 ~ 19.5 ft-lbs) of torque.
- Replace the contact breaker plate, and tighten its screws (3) loosely.
- Replace the kickstarter pedal back on the kick shaft in its original position, and tighten its bolt.
- Replace the right foot peg. A lock washer goes with the bolt.
- Make sure the O rings are in place, and replace the oil filter and drain plug. Tighten the oil filter with 1.5 ~ 2.0 kg-m (11 ~ 14.5 ft-lbs) of torque and the drain plug with 2.0 ~ 2.5 kg-m (14.5 ~ 18 ft-lbs).

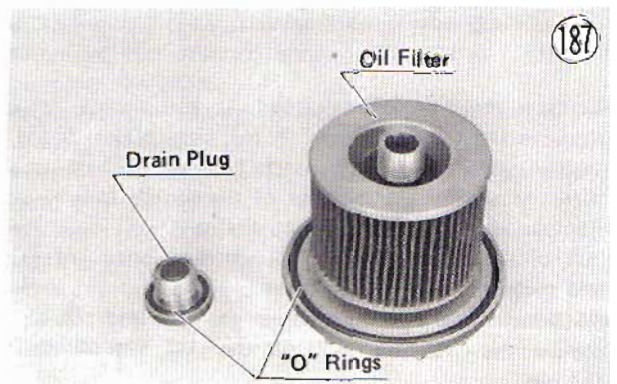

- Fill the engine with oil, check the level (Pg.173), and add more if necessary.
- Adjust the ignition timing (Pg. 12).

## CLUTCH RELEASE

### Removal:

- Take out the shift pedal bolt, and remove the shift pedal.
- Remove the left foot peg bolt, left foot peg, and side stand spring.

- Remove the engine sprocket cover screws (4), and pull the cover free from the crankcase.
- Remove the cotter pin from the clutch release lever, and free the clutch inner cable tip from the lever and engine sprocket cover.

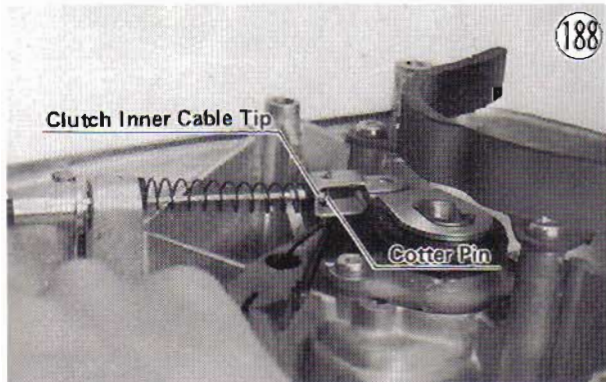

- Remove the chain guard screws (4) to remove the chain guard.

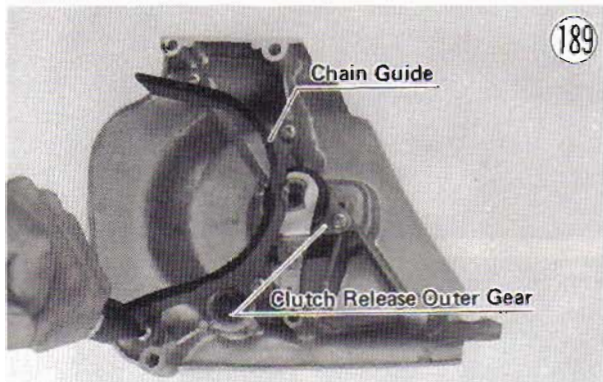

- Remove the clutch release outer gear screws (2), and separate the two gears.

#### Installation:

- Fit the worm gears together so that, as they begin to mesh, the punch mark on the inner gear aligns with the raised point on the outer gear.

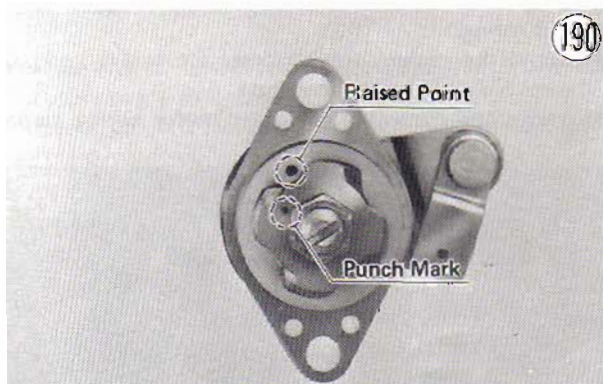

- Fit the clutch release gears back into the engine sprocket cover, apply a non-permanent locking agent to the screws, and then tighten the screws. When the gears are fully meshed, their position should be

as shown in Fig. 191.

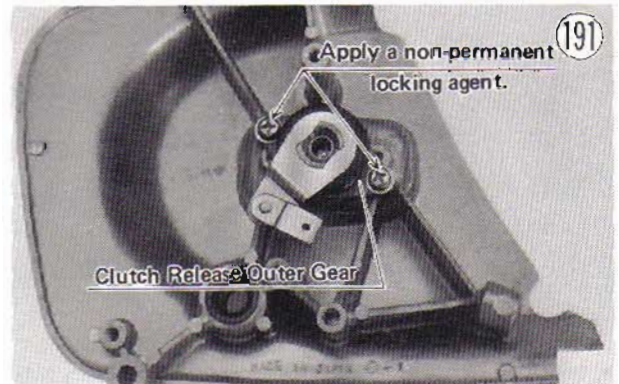

- Apply a non-permanent locking agent to the chain guard screws, and replace the chain guard.
- Run the clutch cable into the engine sprocket cover and spring, and fit the tip of the inner cable into the clutch release lever.
- Using a new cotter pin, secure the cable tip to the release lever.
- Replace the engine sprocket cover using the shift shaft oil seal guide (special tool) to protect the oil seal in the cover, and tighten its screws.



- Fit the side stand spring into place, and then secure the left foot peg with its bolt.
- Replace the shift pedal so that its end matches the level of the dynamo cover lower right screw.

## ENGINE SPROCKET

### Removal:

- Check that the transmission is in neutral.
- Take out the shift pedal bolt, and remove the shift pedal.
- Remove the left foot peg bolt, left foot peg, and side stand spring.
- Remove the engine sprocket cover screws (4), and pull the cover free from the crankcase.
- Remove the dip carefully from the drive chain master link with pliers, remove the master link, and remove the drive chain from the engine sprocket.

## 52 DISASSEMBLY

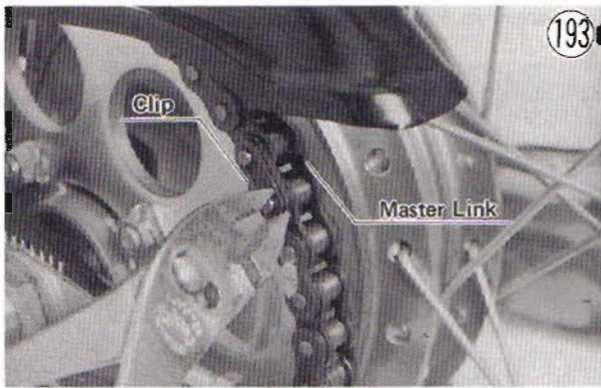

- Straighten the side of the tooth washer that is bent over the side of the engine sprocket nut.
- Hold the engine sprocket steady using the engine sprocket holder (special tool), and remove the engine sprocket nut.



- Pull off the tooth washer and the engine sprocket.

### Installation :

- Replace the engine sprocket and tooth washer, and then tighten the engine sprocket nut with 12 ~ 15 kg-m (87 ~ 108 ft-lbs) of torque while using the engine sprocket holder to keep the sprocket steady. The tooth washer tooth goes into the sprocket hole.
- Bend back one side of the tooth washer over the side of the nut.
- Fit the drive chain back on the sprockets with the ends on the rear sprocket as shown in Fig. 195.

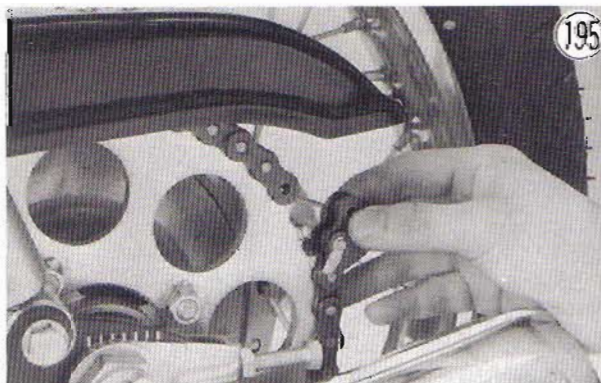

- Replace the chain master link with pliers. The direction of the master link clip should be as shown in Fig. 196.

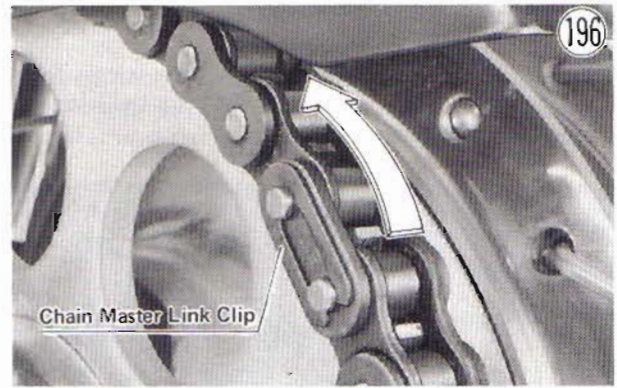

- Replace the engine sprocket cover using the shift shaft oil seal guide (special tool) to protect the oil seal in the cover, and tighten its screws.

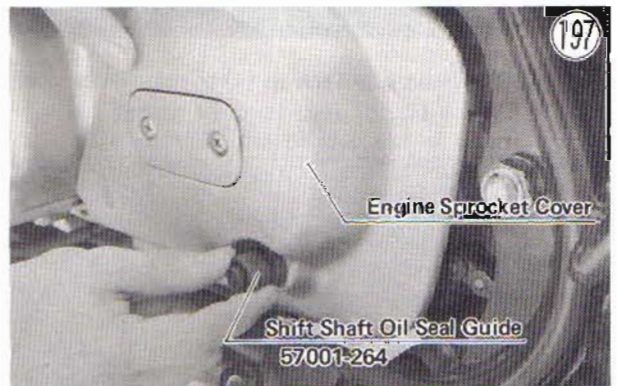

- Fit the side stand spring into place, and then secure the left foot peg with its bolt.
- Replace the shift pedal so that its end matches the level of the dynamo cover lower right screw.

## NEUTRAL INDICATOR SWITCH

### Removal:

- Take out the shift pedal bolt, and remove the shift pedal.
- Remove the left foot peg bolt, left foot peg, and side stand spring.
- Remove the engine sprocket cover screws (4), and pull the cover free from the crankcase.
- Remove the dynamo and starter motor wiring guide.



- Pull off the neutral indicator switch lead from the switch.
- Remove the neutral indicator switch and gasket.



**Installation:**

- Apply a non-permanent locking agent to the threaded portion, and replace the neutral indicator switch and gasket tightening it with 1.5 ~ 2.0 kg-m (11 ~ 14.5 ft-lbs) of torque.
- Fit the lead back on the switch.
- Fit first the starter motor lead and then the dynamo wiring into the wiring guide, and screw the guide back on the crankcase.
- Replace the engine sprocket cover using the shift shaft oil seal guide (special tool) to protect the oil seal, and tighten its screws.



- Fit the side stand spring into place, and then secure the left foot peg with its bolt.
- Replace the shift pedal so that its end matches the level of the dynamo cover lower right screw.

**ENGINE OIL PUMP**

**Removal:**

- Remove the clutch and primary chain (Pg. 48).
- Remove the oil pump screws (4), and pull off the oil pump. There are three O rings in the crankcase.

**Installation Note:**

- Replace any O rings that are deteriorated or damaged.

**Disassembly:**

- Remove the C ring (1) and washer (2).
- Separate the oil pump halves (3) (7), and remove the rotors (4) (5).
- Remove the pin (8), and separate the gear (9) and oil pump half (7).

**Assembly Note:**

- The side of the rotors which has a punch mark faces out.

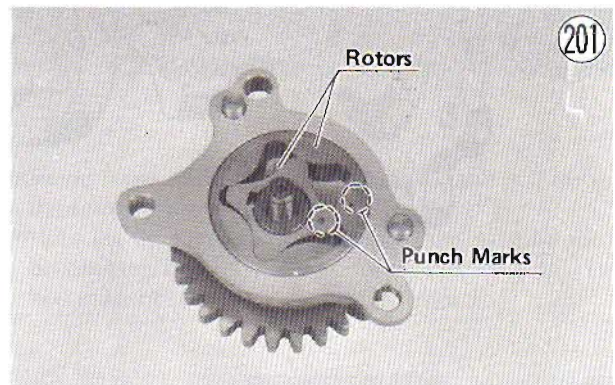

**EXTERNAL SHIFT MECHANISM**

**Removal:**

- Remove the clutch and primary chain (Pg. 48).
- Take out the shift pedal bolt (3), and remove the shift pedal (1).
- Remove the left foot peg bolt, left foot peg, and side stand spring.
- Remove the engine sprocket cover screws (4), and pull the cover free from the crankcase.
- Remove the external shift mechanism stopper (9).
- Move the external shift mechanism pawl (11) out of its position on the end of the shift drum, and pull out the external shift mechanism (7).

**Installation:**

- Insert the shift shaft oil seal guide (special tool) in the crankcase shift shaft oil seal, run the external shift mechanism through the crankcase, and place its arm on the shift drum pins.



- Apply non-permanent locking agent to the screws, and replace the external shift mechanism stopper.

## 54 DISASSEMBLY

### Engine Oil Pump

203

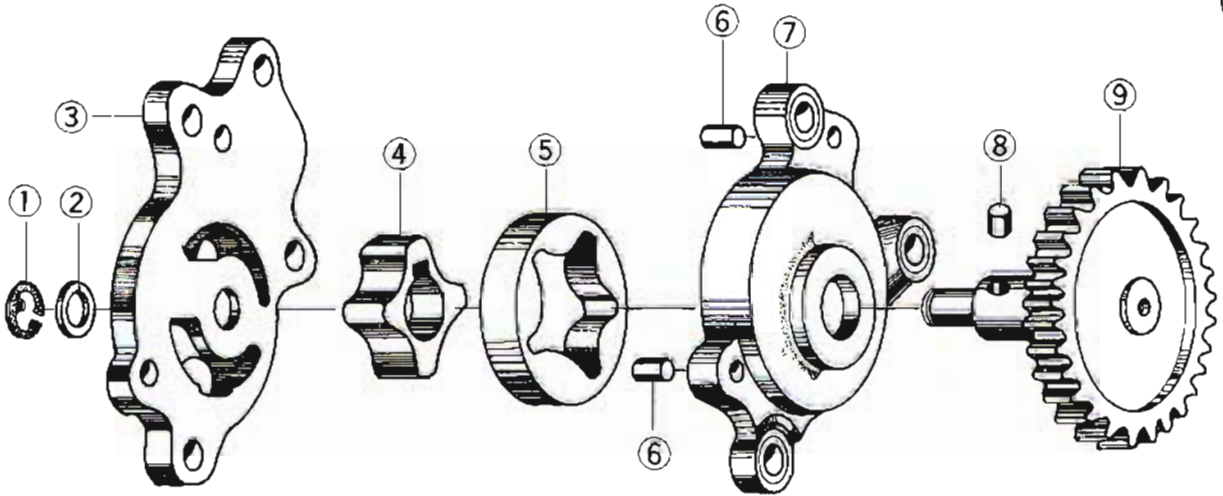

- |                  |                |                  |
|------------------|----------------|------------------|
| 1. C Ring        | 4. Inner Rotor | 7. Oil Pump Half |
| 2. Washer        | 5. Outer Rotor | 8. Pin           |
| 3. Oil Pump Half | 6. Nock Pin    | 9. Oil Pump Gear |

### Shift Mechanism

204

1. Shift Pedal
2. Pedal Rubber
3. Shift Pedal Bolt
4. Lock Nut
5. Return Spring Pin
6. Return Spring
7. Shift Shaft
8. Spring
9. Shift Mechanism Stopper
10. Screw
11. Shift Mechanism Pawl

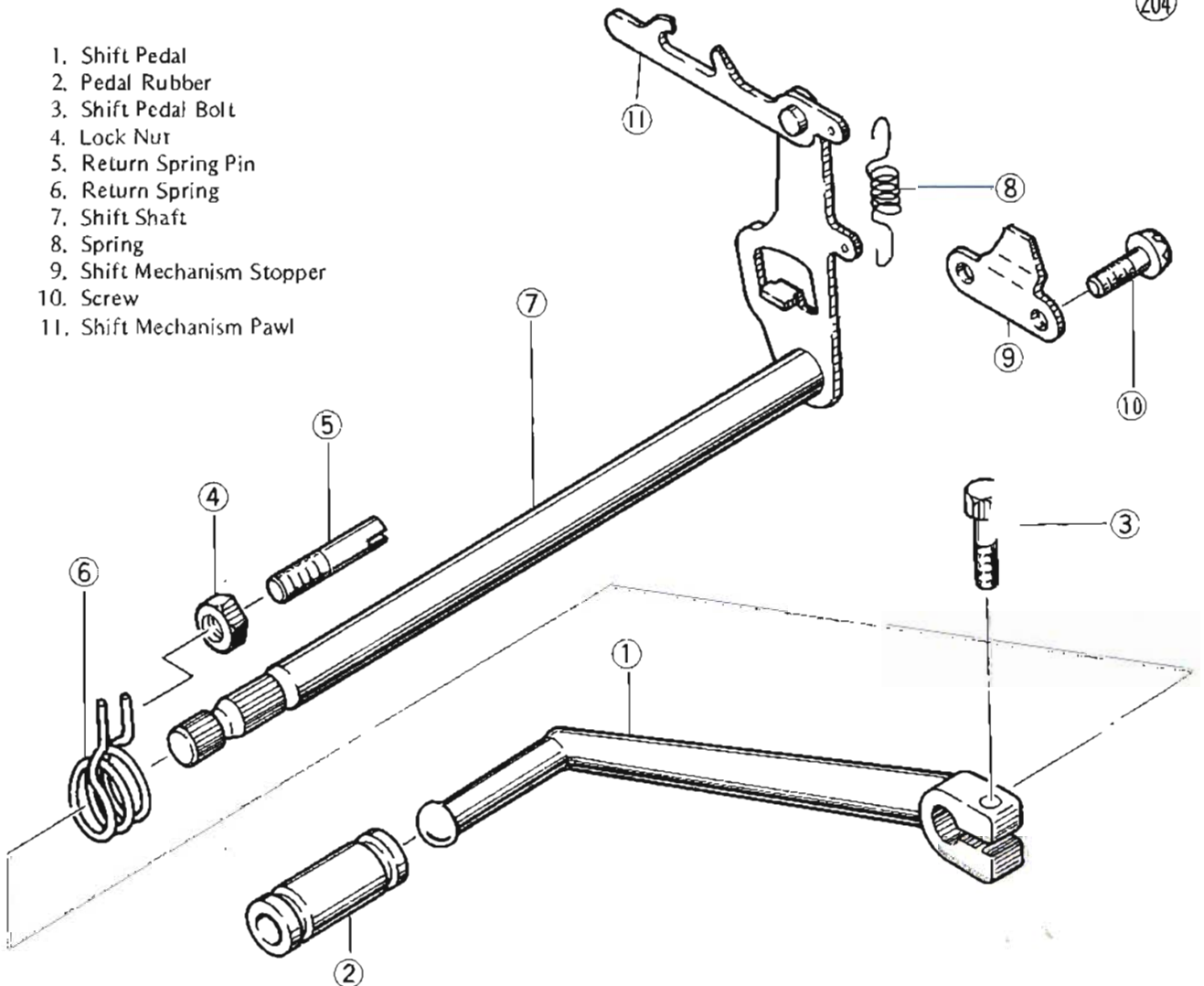

- Replace the engine sprocket cover using the shift shaft oil seal guide (special tool) to protect the oil seal in the cover and tighten its screws.

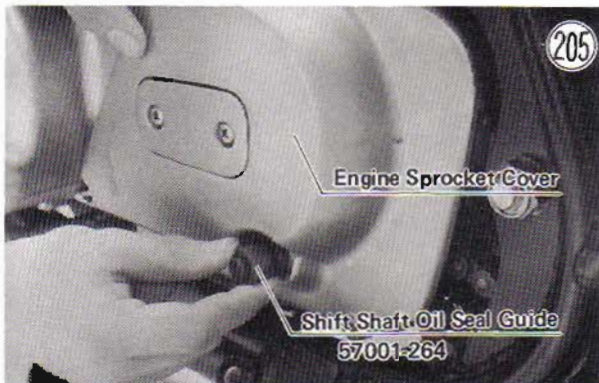

- Fit the side stand spring into place, and then secure the left foot peg with its bolt.
- Replace the shift pedal so that its end matches the level of the dynamo cover lower right screw, and tighten its bolt.
- Install the clutch and primary chain (Pg. 49).

## TRANSMISSION

### Removal:

- Remove the engine (Pg. 22).
- Set the engine on a clean surface or, preferably, into a disassembly apparatus with some means of holding the engine steady while parts are being removed.
- Remove the starter motor cover and gasket.
- Remove the dynamo and starter motor wiring guide.



- Pull the neutral indicator switch lead from the switch.
- Disconnect the oil pressure indicator switch lead, and push it through the starter motor lead hole to free it from the crankcase.

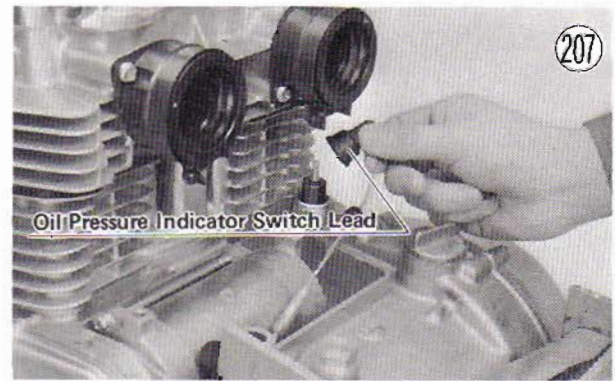

- Remove the dynamo cover screws (8), and pull off the dynamo cover and gasket.
- Hold the dynamo rotor steady with the dynamo rotor holder (special tool), and remove the rotor bolt. The bolt must be turned clockwise for removal.

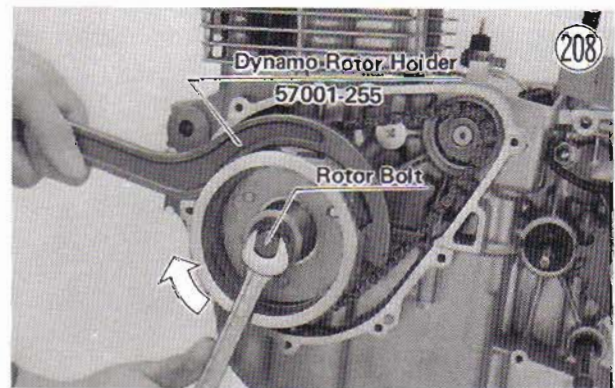

- Using the special tool to hold the rotor steady, remove the rotor and starter clutch assembly with the dynamo rotor puller (special tool). There is a thrust washer at the rear of the rotor.

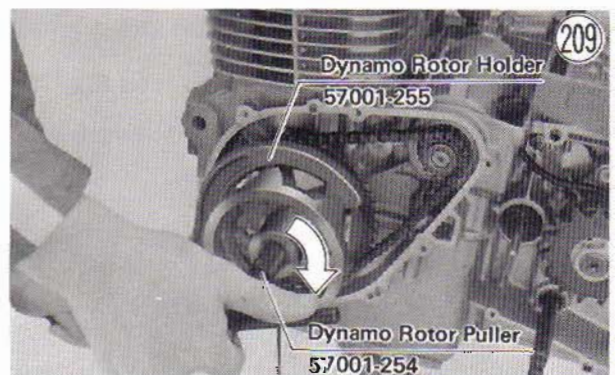

- Pull off the starter motor sprockets and chain.
- Remove the starter motor retaining bolts (2).
- Tap lightly on the starter motor body as shown in Fig. 210, and pull out the starter motor.

## 56 DISASSEMBLY

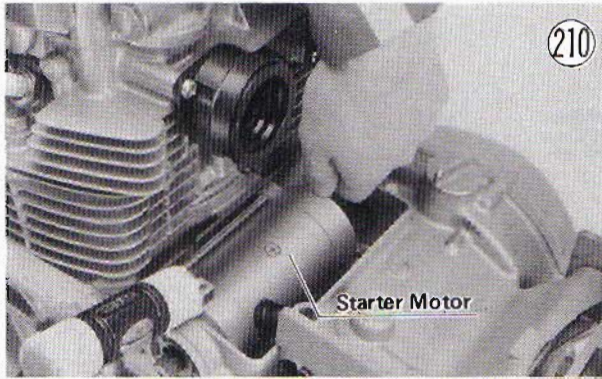

**CAUTION:** Do not tap on the starter motor shaft. Tapping on the shaft may damage the motor.

- Remove the contact breaker cover and gasket.
- Take out the contact breaker plate screws (3), and remove the plate.
- With one wrench on the crankshaft rotation nut to keep the shaft from turning, remove the bolt, and take off the timing advancer.



- Mark the position of the kickstarter pedal so that it can later be replaced on the shaft in the same position.
- Remove the kickstarter pedal bolt, and remove the kickstarter pedal.
- Remove the screws (12), and pull off the engine cover and gasket.
- Remove the clutch bolts, washers, and springs (4 ea).
- Pull off the spring plate and spring plate pusher.
- Push in on the push rod to remove the steel ball.

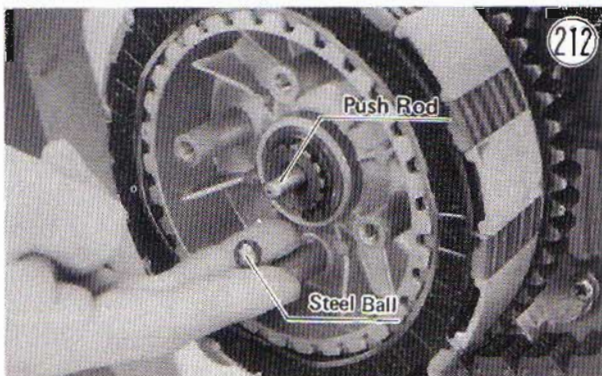

- Remove the clutch hub circlip and shim(s).

- Remove the friction plates (6), steel rings (6), steel plates (5), and clutch hub. There is a thrust washer at the rear of the clutch hub.
- Remove the primary sprocket circlip.

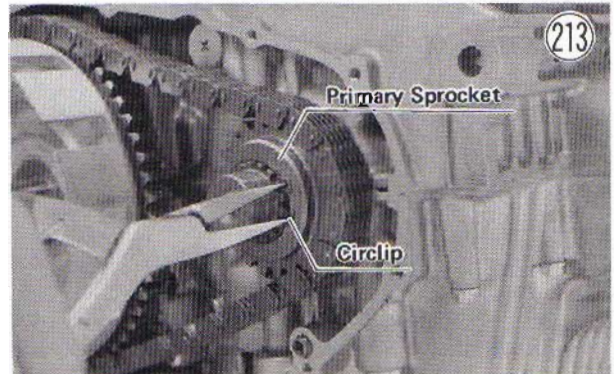

- Pull off the clutch housing, primary sprocket, and primary chain together.
- Remove the external shift mechanism stopper.

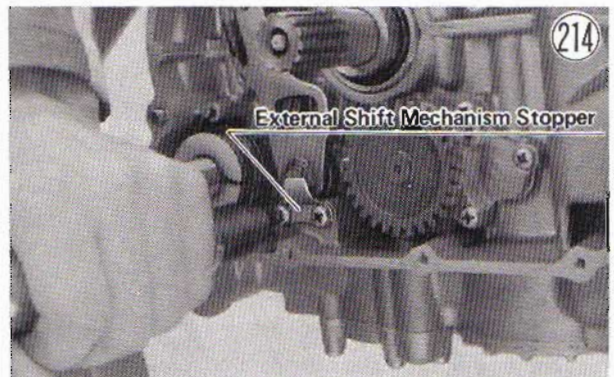

- Move the external shift mechanism pawl out of its position on the end of the shift drum, and pull out the external shift mechanism.
- Remove the upper crankcase half bolts (6) and carburetor tube guide.
- Turn the engine upside down, and remove the lower crankcase half bolts (14).
- Lift off the lower crankcase half.
- Remove the oil passage O ring.

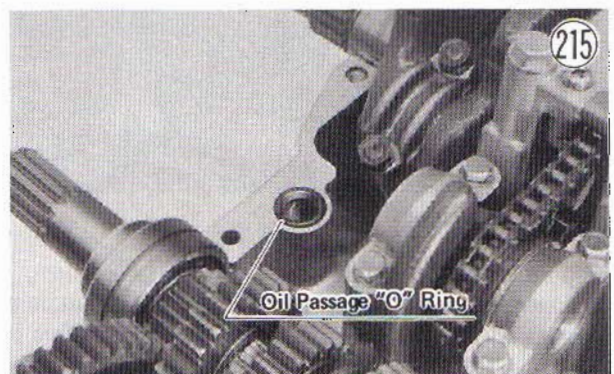

- Take out the drive shaft and output shaft assemblies.
- Remove the shift drum stopper.

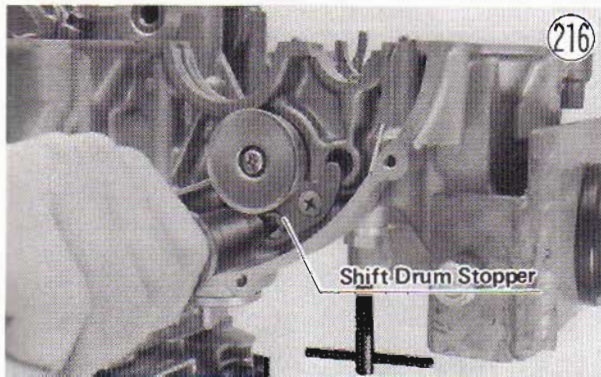

- Remove the shift drum positioning bolt, O ring, spring, and pin.

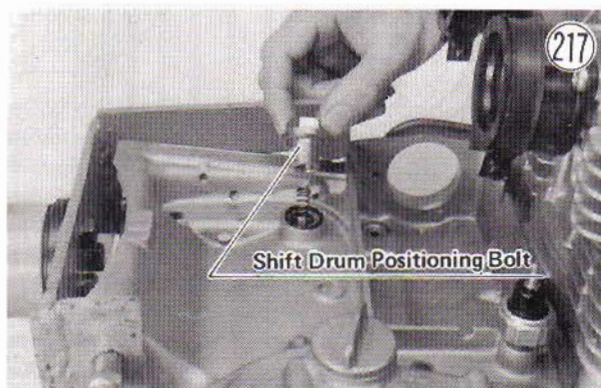

- Remove the drive shaft 3rd gear shift fork cotter pin, and pull out the shift fork guide pin.
- Remove the operating plate circlip.
- Pull out the shift drum, and remove the operating plate and drive shaft 3rd gear shift fork.
- Pull out the shift rod, and remove the two remaining shift forks.

**Installation:**

- Remove the sump plate, clean out the lower crankcase half thoroughly, and then replace the sump plate. Use a non-permanent locking agent on the sump plate screws.
- Insert the shift rod running it through the output shaft 4th gear shift fork and then through the output shaft 5th gear shift fork. The output shaft 4th gear shift fork guide pin is more centrally located than on the other shift fork.

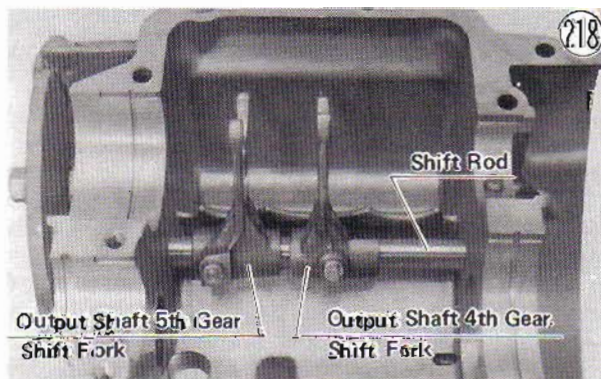

- Insert the shift drum into the crankcase part way, and fit the drive shaft 3rd gear shift fork on the drum with the part which houses the pin facing the crankshaft.



- Check to see that the operating plate pin is in place, fit the operating plate onto the end of the shift drum with the nub facing out, and replace the circlip.

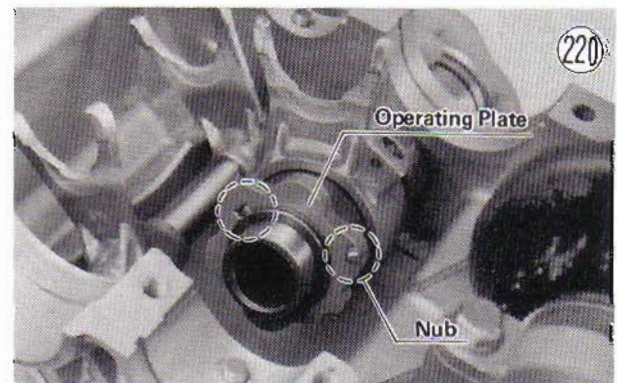

- Insert the shift fork guide pin and cotter pin and bend back the ends of the cotter pin.
- Push the shift drum in the rest of the way, and have each shift fork guide pin riding in its drum groove.
- Check that the drive shaft and output shaft set rings and the oil passage nozzle are in place, and daub a little engine oil on the set rings, blow the oil passage nozzle clean with compressed air.



- Fit the output shaft and drive shaft assemblies fully into place.
- Replace the shift drum stopper, and punch the screws after tightening its screws.
- Replace the shift drum positioning pin, spring, O ring, and bolt.

## 58 DISASSEMBLY

- Check that the drive shaft assembly, output shaft assembly, and shift drum all turn easily.
- Replace the oil passage O ring.
- Check to see that the following parts are in place: oil pressure relief valve, output shaft oil cup, crankshaft plain bearings (2), push rod oil seal, crankshaft oil seal (wire band side facing in). Apply a little engine oil to all bearings.

### Lower Crankcase Half

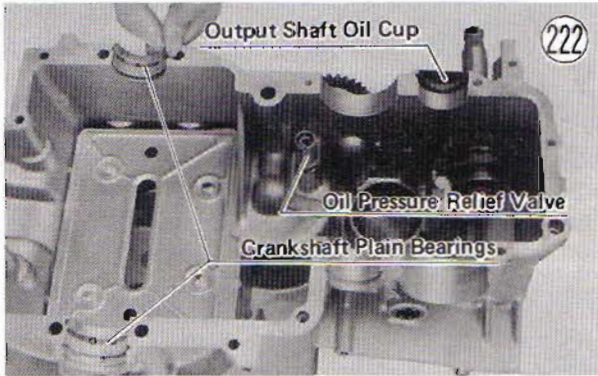

### Upper Crankcase Half

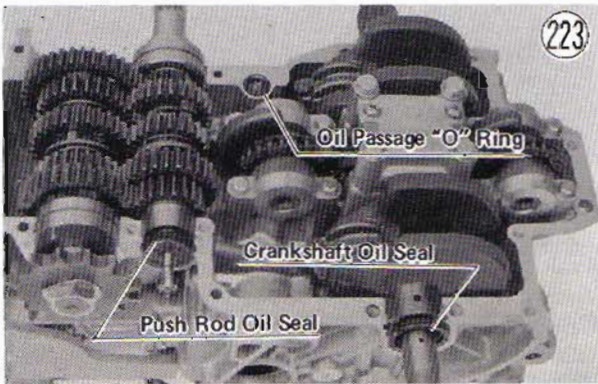

- Clean off and wipe dry the fitting surfaces of the crankcase halves, and apply liquid gasket to the fitting surface of the upper crankcase half.
- Fit the lower crankcase half on the upper crankcase half, and replace the lower crankcase half bolts (14). Tighten first the 8 mm bolts (4) in the sequence shown in Fig. 224, tightening first each bolt to 1.5 kg-m (11 ft-lbs) of torque and then 2.5~3.0 kg-m (18~22 ft-lbs). Next, tighten the 6 mm bolts all lightly and then with 0.8~1.0 kg-m (69~87 in-lbs).
- Turn the engine right side up, and then tighten the upper crankcase half bolts (6) with 0.8~1.0 kg-m (69~87 in-lbs) of torque. Include the carburetor tube guide with its bolt.
- Insert the shift shaft oil seal guide (special tool) in the crankcase shift shaft oil seal, run the external shift mechanism shaft through the crankcase, and place its arm on the shift drum pins.

### Crankcase Bolts Tightening Order

224

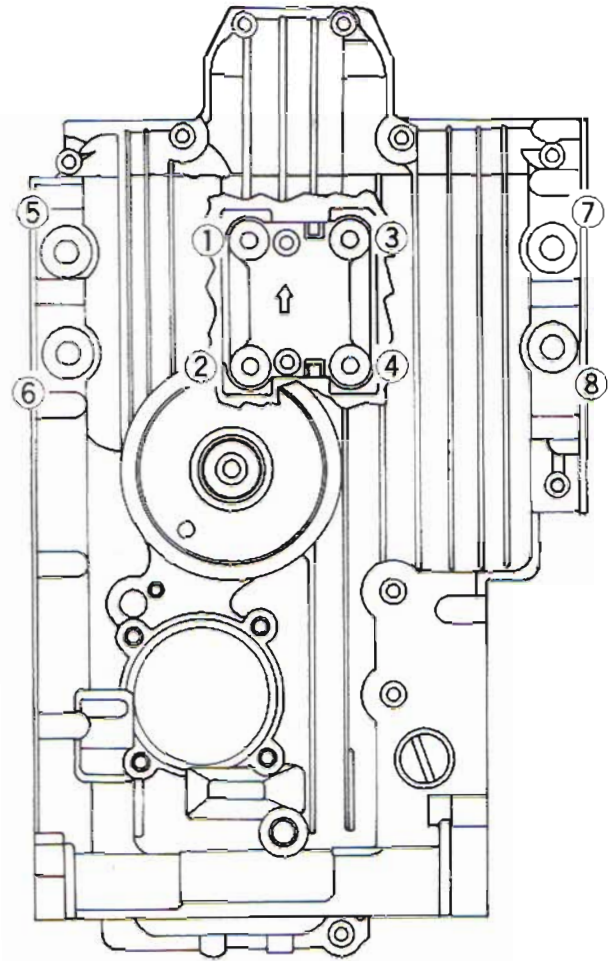

- Apply a non-permanent locking agent to the screws, replace the external shift mechanism stopper, and tighten the screws.
- Fit the primary chain on the clutch housing and primary sprocket, and fit the assembly into place. The protruding side of the primary sprocket faces out. Turn the oil pump gear by hand if necessary.

so that it meshes with the oil pump drive gear.

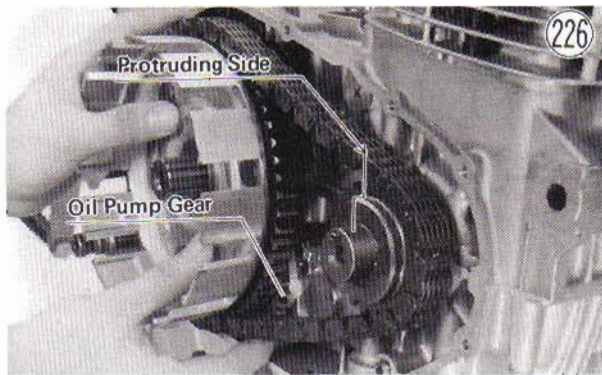

- Replace the primary sprocket circlip.
- Replace the thrust washer (thick) and the clutch hub.
- Replace the shim(s) and clutch hub circlip. The shim(s) should take up all the play between the hub and circlip. If not, add more shim(s).
- Replace the friction plates (6), steel rings (6) and steel plates (5). The sequence is friction plate, steel ring, steel plate, friction plate finishing with a steel ring.
- Insert the ball bearing and spring plate pusher.
- Replace the spring plate aligning the raised points on the plate with the punch marks on the hub.

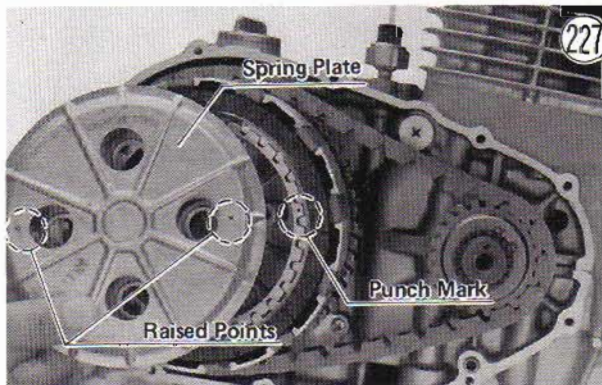

- Replace the spring bolts (4), each with its washer and spring. Tighten them evenly in a cross pattern by hand rather than using compressed air, which might make spring pressure uneven.
- Check that the wire band in the engine cover crankshaft oil seal has not slipped out of its proper position.
- Using a new engine cover gasket, fit the engine cover onto the crankcase. Use the kick shaft oil seal guide (special tool) to protect the kick shaft oil seal. Tighten the engine cover screws (12) firmly. Be sure to include the contact breaker lead clamp with its engine cover screw.



- Fit the timing advancer onto the crankshaft matching its notch with the pin on the end of the crankshaft, and tighten its bolt with 2.3 ~ 2.7 kg-m (16.5 ~ 19.5 ft-lbs) of torque.
- Replace the contact breaker plate, and tighten its screws (3) loosely.
- Replace the contact breaker cover and gasket.
- Place the kickstarter pedal into its original position, and tighten its bolt.
- Run the starter motor lead through its crankcase hole, daub a little oil on the starter motor O ring, and place the starter motor back into position.
- Apply a non-permanent locking agent to the starter motor retaining bolts, and then tighten the bolts. Each bolt has a flat washer.
- Fit the starter motor chain on its sprockets, and push the sprockets back into place.
- Apply a small amount of heat durable grease to the thrust washer, clean off any oil or dirt that may be on the crankshaft taper or rotor hub, and replace it to the rear of the rotor. Place the assembly back on the crankshaft.
- Apply a non-permanent locking agent to the rotor bolt threads, and then tighten the bolt to 6.5 ~ 7.0 kg-m (47 ~ 51 ft-lbs) of torque while holding the dynamo rotor steady with the dynamo rotor holder (special tool).
- Replace the dynamo cover, gasket, and screws (8).
- Run the oil pressure indicator switch lead through the starter motor lead hole, and connect it to the switch lead.
- Connect the neutral indicator switch lead to the switch.
- Fit first the starter motor lead and then the dynamo wiring into the wiring guide, and screw the guide back on the crankcase.
- Replace the starter motor cover and gasket.
- Install the engine (Pg. 24).
- Adjust the ignition timing (Pg. 12).

#### Shift Drum Disassembly:

- Drop out the operating plate pin (28).
- Remove the shift drum pin plate (35). The screw has a lock washer (37).
- Pull out the pins (35) (6).
- To remove the shift drum needle bearing (26), use a hook or some other tool to pull it out of the crankcase wall. Removal necessitates replacement for a new one.

# 60 DISASSEMBLY

## Shift Drum, Drive Shaft, Output Shaft

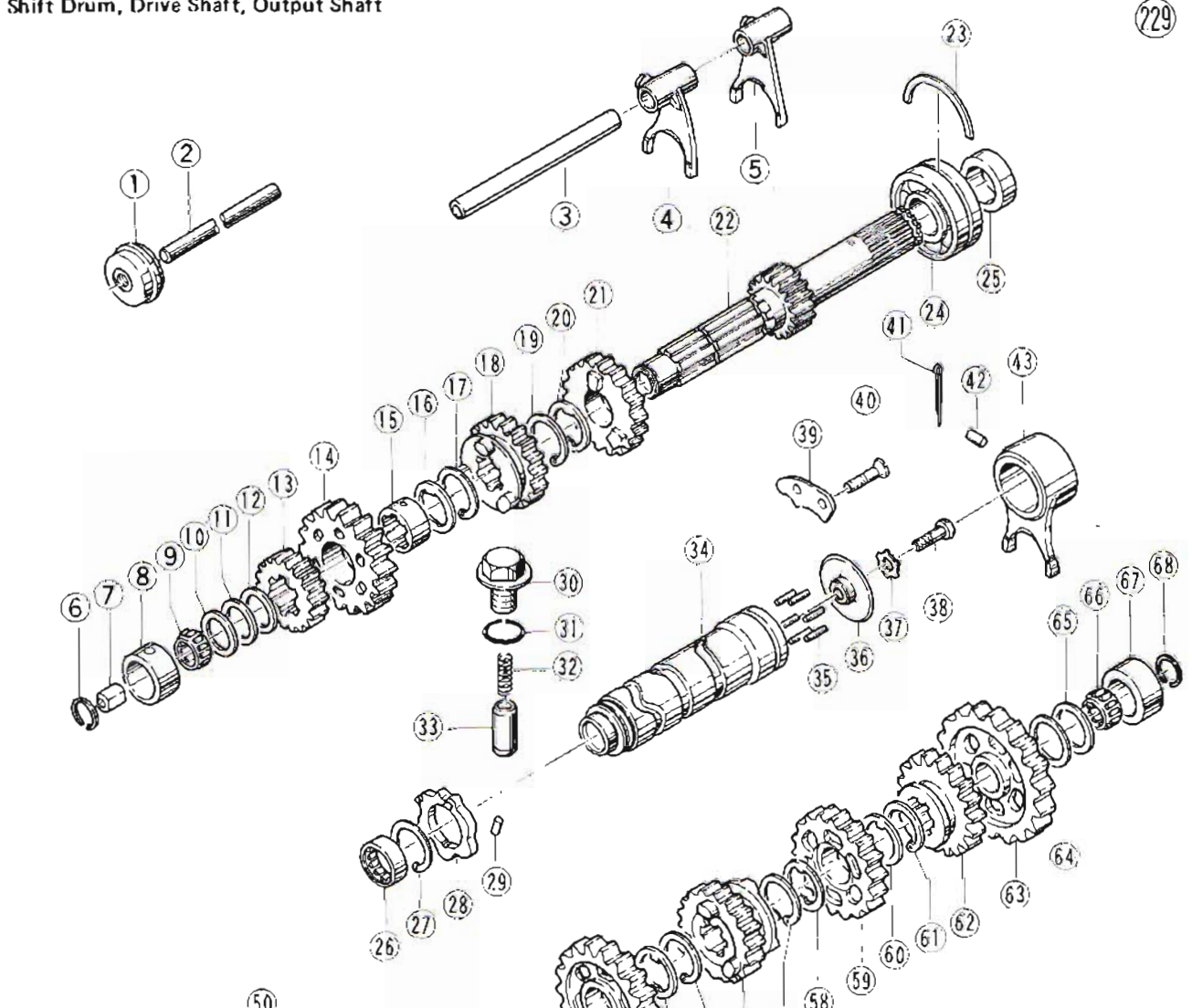

- 1. Oil Seal
- 2. Clutch Push Rod
- 3. Shift Rod
- 4. 5th Gear Shift Fork
- 5. 4th Gear Shift Fork
- 6. Circlip
- 7. Bush
- 8. Needle Bearing Bushing

- 9. Needle Bearing
- 10. Shim
- 11. Shim (Bronze)
- 12. Shim
- 13. 2nd Gear (D)
- 14. 5th Gear (D)
- 15. Copper Bushing
- 16. Spline Washer
- 17. Circlip
- 18. 3rd Gear (D)
- 19. Circlip
- 20. Spline Washer
- 21. 4th Gear (D)
- 22. Drive Shaft
- 23. Set Ring
- 24. Ball Bearing

- 25. Drive Shaft Bushing
- 26. Shift Drum Needle Bearing
- 27. Circlip
- 28. Operating Plate
- 29. Operating Plate Pin
- 30. Drum Positioning Bolt
- 31. O Ring
- 32. Spring
- 33. Pin
- 34. Shift Drum
- 35. Pins
- 36. Drum Pin Plate
- 37. Lock Washer
- 38. Screw
- 39. Shift Drum Stopper
- 40. Screw
- 41. Cotter Pin
- 42. Guide Pin
- 43. 3rd Gear Shift Fork
- 44. Engine Sprocket Nut

- 45. Tooth Washer
- 46. Engine Sprocket
- 47. Output Shaft Collar
- 48. O Ring
- 49. Oil Seal
- 50. Set Ring
- 51. Ball Bearing
- 52. Output Shaft
- 53. 2nd Gear (O)
- 54. Spline Washer
- 55. Circlip
- 56. 5th Gear
- 57. Circlip
- 58. Spline Washer
- 59. 3rd Gear (O)
- 60. Spline Washer
- 61. Circlip
- 62. 4th Gear (O)
- 63. 1st Gear (O)
- 64. Shim
- 65. Shim
- 66. Needle Bearing
- 67. Needle Bearing Bushing
- 68. Circlip

**Shift Drum Assembly Notes:**

1. To install a new shift drum needle bearing, use the shift drum bearing driver (special tool) to drive it in.



2. Be sure that the screw is firmly tightened.

**Drive Shaft Disassembly:**

- Pull out the clutch push rod (2) with its oil seal (1).
- Pull off the needle bearing bushing (8).
- Remove the circlip (6), and pull off the needle bearing (9) and shim(s) (10, 11, 12).
- Pull off 2nd gear (13), 5th gear (14), copper bushing (15), and spline washer (16).
- Remove the circlip (17), and pull off 3rd gear (18).
- Remove the circlip (19), and pull off the spline washer (20) and 4th gear (21).
- Pull off the drive shaft bushing (22) and ball bearing (23) together using the stem bearing puller and adapter (special tools).

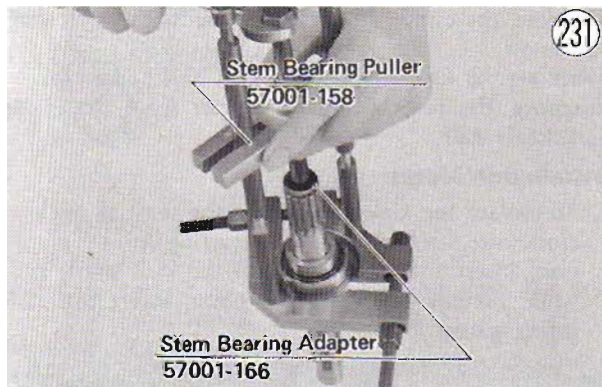
**Drive Shaft Assembly Notes:**

1. Replace the drive shaft ball bearing and bushing using the transmission circlip driver (special tool).

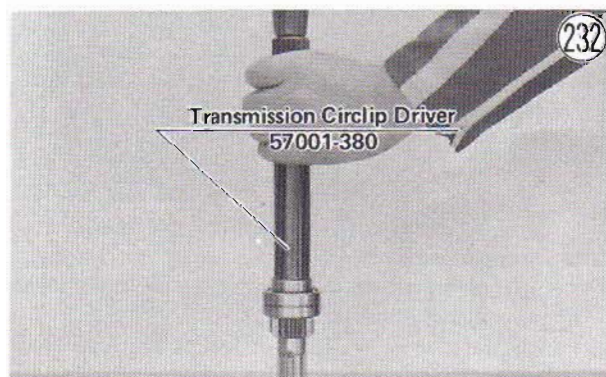

2. Be sure that all parts are put back in the correct sequence and all circlips are properly in place (replace any that are bent or damaged). Proper sequence from 1st gear is 1st gear, 4th gear, spline washer, circlip, 3rd gear, circlip, spline washer, copper bushing, 5th gear, 2nd gear, shim(s), needle bearing, circlip, and needle bearing bushing. The shim(s) should take up all the play. If not, add more shim (s).
3. 1st gear—part of drive shaft  
4th gear—dogged, dogs face 3rd gear  
3rd gear—double dogged, tooth side dogs face 4th gear, 22 teeth  
5th gear—dog recesses, dog recess side faces 3rd gear  
2nd gear—no dogs, no dog recesses
4. Use the transmission circlip driver (special tool) to replace the two inner circlips without damage. To use the tool, fit the inner part on the shaft with the end at the circlip groove, set the circlip on the end of the inner part, place the driver against the circlip, and use a hammer to tap the circlip into place.

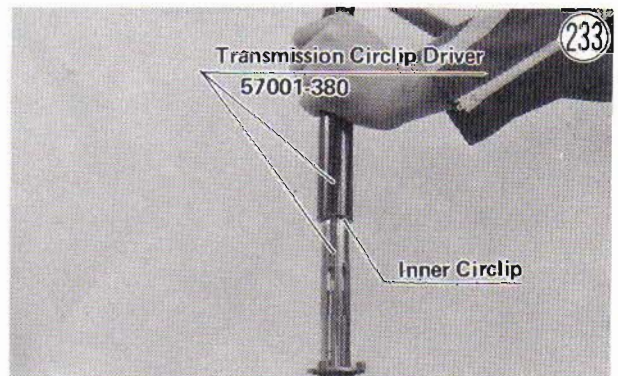

5. Fit the copper bushing and 3rd gear with their oil holes matching the oil holes in the shaft.
6. Apply a thin coat of heat durable grease to the push rod before insertion.

**Output Shaft Disassembly:**

- Pull off the needle bearing bushing (67).
- Remove the circlip (68), and pull off the needle bearing (66) and shim(s) (64, 65).
- Pull off 1st gear (63) and 4th gear (62).
- Remove the circlip (61), and pull off the spline washer (60), 3rd gear (59), and spline washer (58).
- Remove the circlip (57), and pull off 5th gear (56).
- Remove the circlip (55), and pull off the spline washer (54) and 2nd gear (53).
- Straighten the side of the tooth washer (45) that is bent over the side of the engine sprocket nut (44).
- Hold the engine sprocket steady using the engine sprocket holder (special tool), and remove the engine sprocket nut.

## 62 DISASSEMBLY

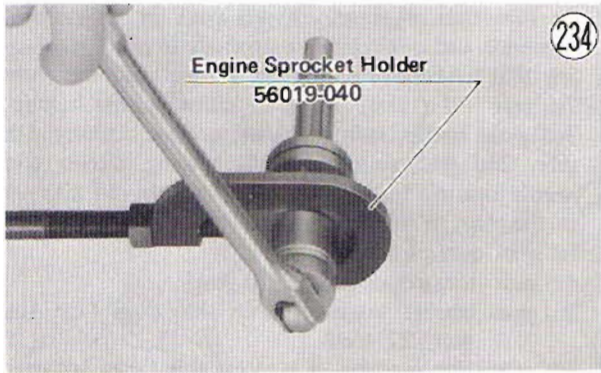

- Pull off the tooth washer and the engine sprocket ④⑥.
- Slide off the oil seal ④⑨.
- Pull off the output shaft collar ④⑦ and O ring ④⑧.
- To remove the output shaft ball bearing ⑤①, first fit the stem bearing puller (special tool) into place upside down, and tighten to create a space between the bearing and flange. Next, fit the puller on right side up, and pull off the bearing.

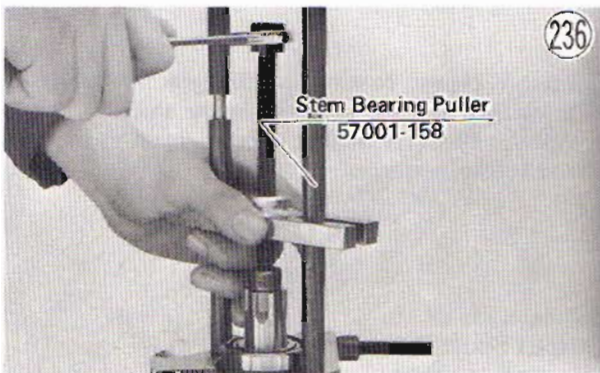
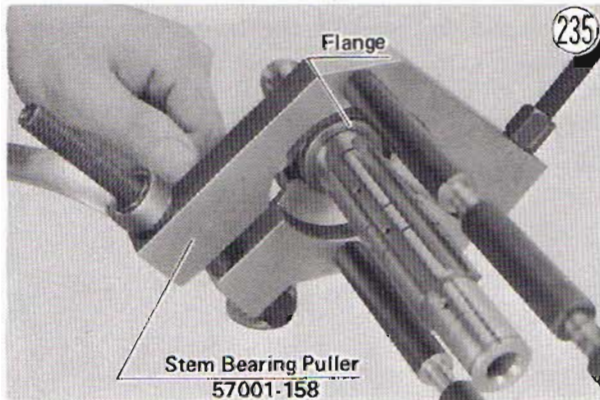

### Output Shaft Assembly Notes:

1. Replace the output shaft ball bearing using the transmission circlip driver (special tool).
2. Replace the O ring if damaged.
3. Be sure that all parts are put back in the correct sequence and all circlips are properly in place (replace any that are bent or damaged). Proper sequence from the engine sprocket side is 2nd gear, spline washer, circlip, 5th gear, circlip, spline washer, 3rd gear, spline washer, circlip, 4th gear, 1st gear, shim(s), needle bearing, circlip, and needle bearing bushing. The

shim(s) should take up all the play. If not, add more shim(s).

4. 2nd gear—dog holes, side which is sunk further in faces 5th gear  
5th gear—double dogged, tooth side dogs face 2nd gear  
3rd gear—dog recesses, recess side faces 5th gear  
4th gear—single dogged, dog side faces 1st gear  
1st gear—dog holes, side which is sunk further in faces 4th gear
5. Use the transmission circlip driver (special tool) to replace the three inner circlips without damage.
6. Be sure that the ball bearing oil seal wire band side faces in.
7. Tighten the engine sprocket nut to 12 ~ 15 kg-m (87 ~ 108 ft-lbs) of torque, using the engine sprocket holder to keep the sprocket steady. Be sure to bend back one side of the tooth washer over the side of the nut.

## KICKSTARTER

### Removal:

- Split the crankcase as explained in transmission removal (Pg. 55). The transmission itself does not require removal.
- Straighten out the washer ② ends which are bent over the side of the ratchet gear arm stopper bolts ①, and remove the stopper ③.
- Remove the circlip ②⑤ which holds the spring guide ④ in place.
- Pull off the spring guide.
- Remove the kick spring ⑩.
- Remove the circlip ⑬ which is against the kick shaft collar ⑪.
- Remove the kick shaft stopper ⑰ and collar.
- Remove the rest of the kickstarter from the lower crankcase half.

### Installation Notes:

1. To replace the kick spring, turn the shaft all the way clockwise, insert one end of the spring into the crankcase, insert the other end into the kick shaft, and, while holding the spring in place, insert the kick spring guide.

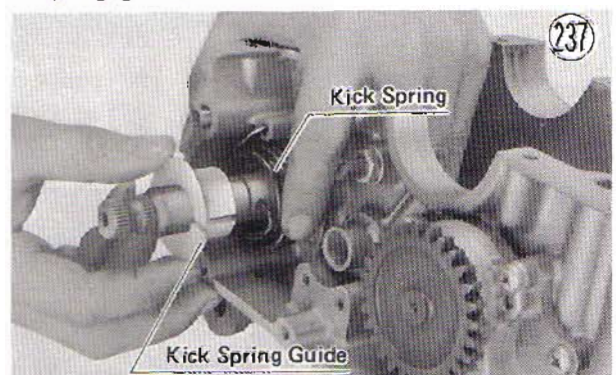

2. Be sure to bend back the ends of the washer over the stopper bolts.
3. Apply a thin coat of heat durable grease to the inside of the collar before replacement.
4. Punch the screws ⑱ after installing the kick shaft stopper.

Kickstarter

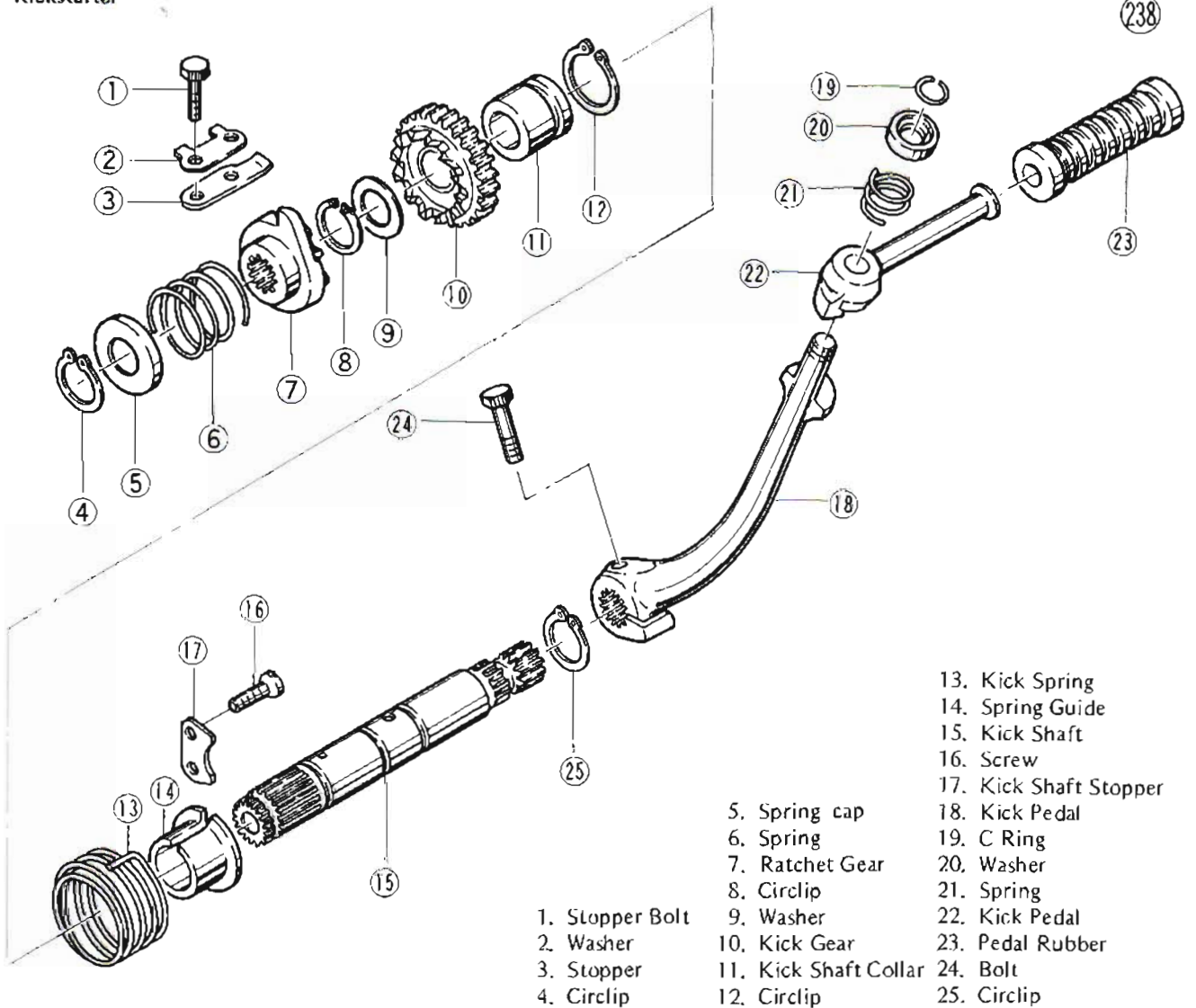

- 1. Stopper Bolt
- 2. Washer
- 3. Stopper
- 4. Circlip
- 5. Spring cap
- 6. Spring
- 7. Ratchet Gear
- 8. Circlip
- 9. Washer
- 10. Kick Gear
- 11. Kick Shaft Collar
- 12. Circlip
- 13. Kick Spring
- 14. Spring Guide
- 15. Kick Shaft
- 16. Screw
- 17. Kick Shaft Stopper
- 18. Kick Pedal
- 19. C Ring
- 20. Washer
- 21. Spring
- 22. Kick Pedal
- 23. Pedal Rubber
- 24. Bolt
- 25. Circlip

**Disassembly:**

- Pull off the kick gear 10 and thrust washer 9.
- Remove the circlip 4 on the spring side, and take off the spring cap 5, and spring 6.
- Pull off the kick ratchet gear 7.
- Remove the remaining circlip 8.

**Assembly Note:**

- For replacing the ratchet gear, align the ratchet gear punch mark with the notch on the kick shaft.

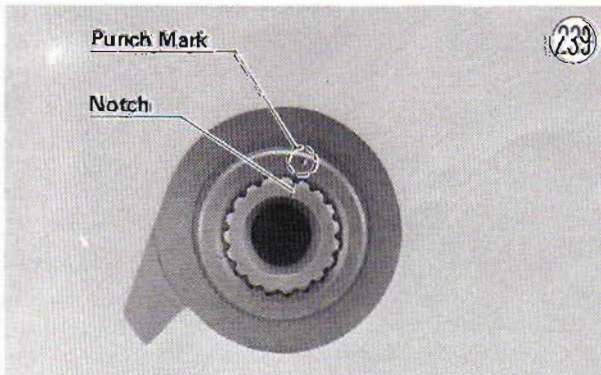

**OIL PRESSURE RELIEF VALVE**

**Removal:**

- Split the crankcase as explained in transmission removal (Pg. 55). The transmission itself does not require removal.
- Unscrew the valve from the lower crankcase half.

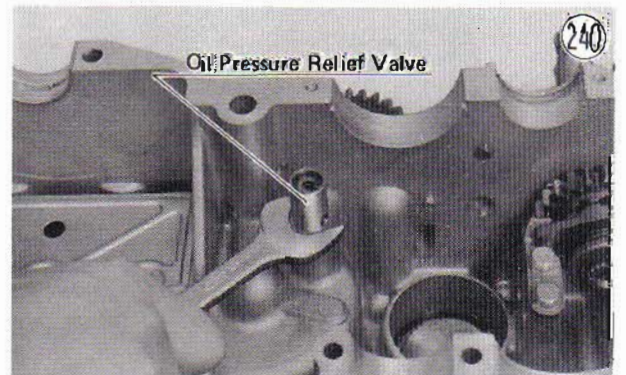

**Installation Note:**

- Use a non-permanent locking agent on the valve threads.

## 64 DISASSEMBLY

### Disassembly:

- Remove the circlip, and take out the washer, spring, and valve piston.

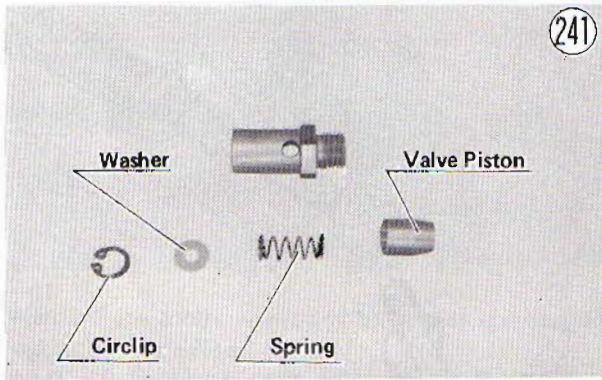

### Installation:

- Check to see that the holder O rings (4) and the pin are all in place.

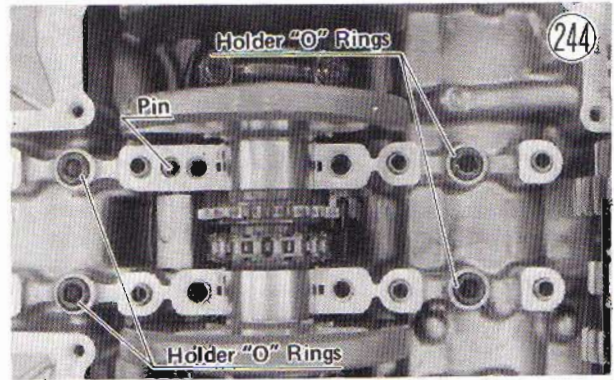

## BALANCER MECHANISM

### Removal:

- Split the crankcase as explained in transmission removal (Pg. 55). The transmission itself does not require removal if only the balancer mechanism is to be removed.
- Remove the bolts (4) and screws (2), and lift off the crankshaft bearing cap. Tap lightly on the sides of the cap with a plastic hammer if necessary to facilitate removal.



- Remove the balancer chain guide from the chain.

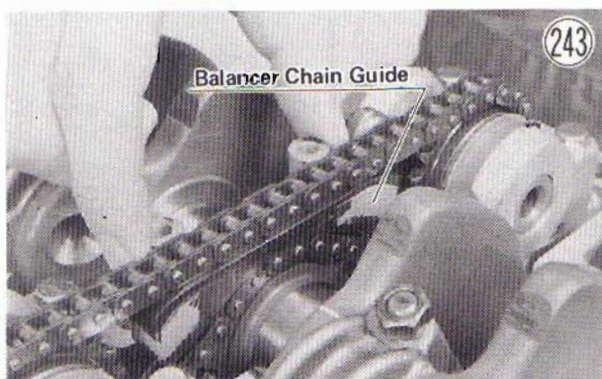

- Remove the balancer mechanism holder bolts (8).
- Tap lightly on the sides of each holder, and then lift off the entire balancer mechanism.

- Turn the crankshaft so that the crankshaft oil holes are even with the upper crankcase half surface with the flywheels positioned up as shown in Fig. 245. If necessary, temporarily replace the timing advancer and use a 17 mm wrench to turn the crankshaft.

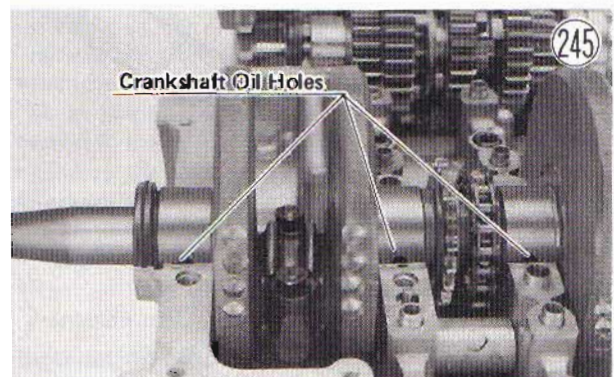

- Check to see that the mechanism is correctly assembled.
- Holding the chain taut, pick up the balancer mechanism, place one of the units into position, and match the sprocket punch mark with the line on the holder. Keeping the chain in its proper position on the sprockets, let the chain fall in place on the crankshaft balancer sprocket, and fit the other unit into place.

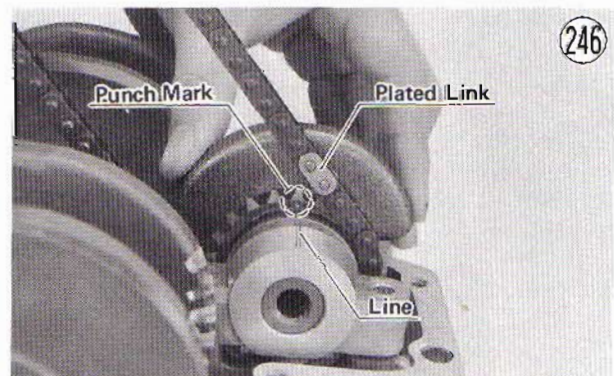

- Check to see that the chrome plated link aligns with the holder line for each balancer unit, and that the balancer weights face up, not cocked to either side.

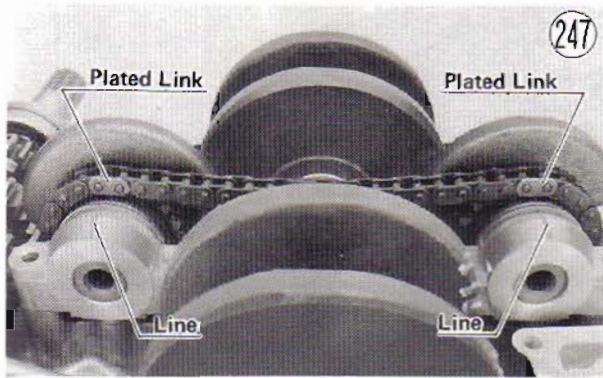

- If the weights are cocked to one side, alter the position of the chain on the crankshaft balancer sprocket until the weights are positioned properly.
- Replace and tighten the bolts for each unit with 1.4~1.6 kg-m (10~11.5 in-lbs) of torque. Make sure that each holder fits all the way down on its knock pins.
- Daub a little engine oil on the plain bearings on the crankshaft bearing cap.
- Place the balancer chain guide into position, set the crankshaft bearing cap into place with the arrow pointing to the front, and then tighten the screws (2) to secure the guide to the cap. Use a non-permanent locking agent on the screws. A chain guide and two plain bearings go with the cap.
- Tighten the bolts (4) in the sequence shown in Fig. 248 first to 1.5 kg-m (11 ft-lbs) of torque and then to 2.5~3.0 kg-m (18~22 ft-lbs).

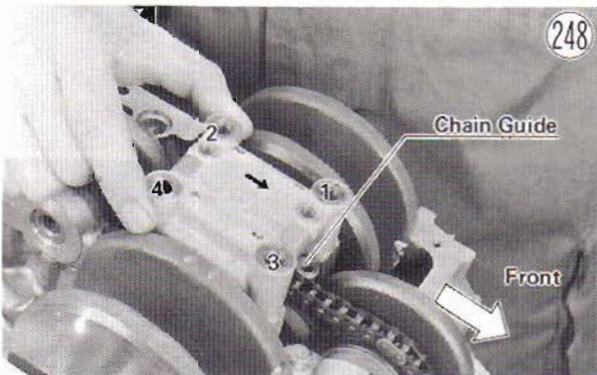

- Fit the crankcase as explained transmission installation (Pg. 58).

**Disassembly (per balancer unit):**

- Remove the chain (1).
- Slide off each holder (2) (1) and the shims (3) (4).
- Tapping lightly with a plastic hammer, remove the sprocket (5). The springs (8) and pins (7) (4 ea) may be removed.
- Take out the balancer weight bolt (9), and slide the weight (10) off the shaft (6).

**Assembly (per balancer unit):**

- Apply oil to the shaft, and insert it into the balancer weight. Match the larger shaft hole with the hole in the center of the weight, apply a non-permanent locking agent to the bolt, and insert it. Tighten the bolt with

1.1~1.3 kg-m (95~113 in-lbs) of torque.

- With the springs and pins (4 ea) all in place in the inner circumference, replace the sprocket. The punch mark on the sprocket must face out, and the sprocket positioned as depicted in Fig. 249. Only one of the four possible positions is correct.

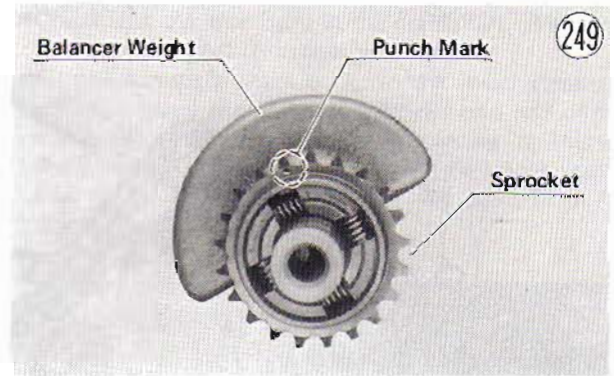

- Replace the shims on the sprocket side. The smaller diameter shim goes on first.
- Replace the holders onto the shaft with the machined side of each holder facing in.

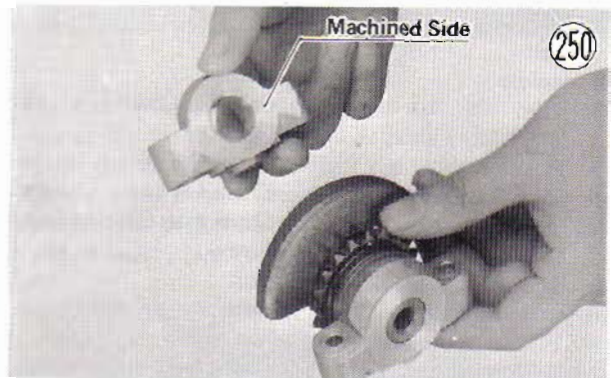

- Replace the chain on the sprockets. For each sprocket, the chrome plated link must fit on the sprocket tooth with the punch mark. Also, the arrows on the holders must point so that they will point away from the crankshaft.

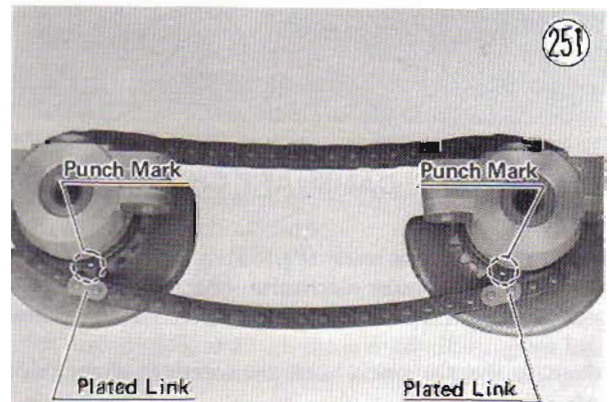

## 66 DISASSEMBLY

### Balancer Mechanism

252

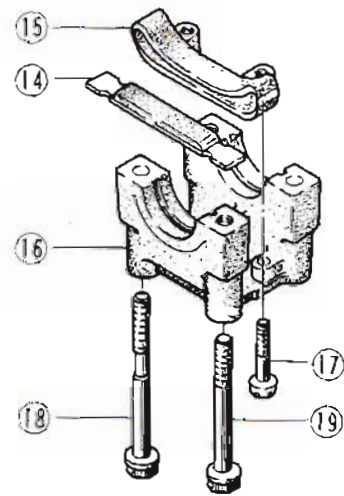
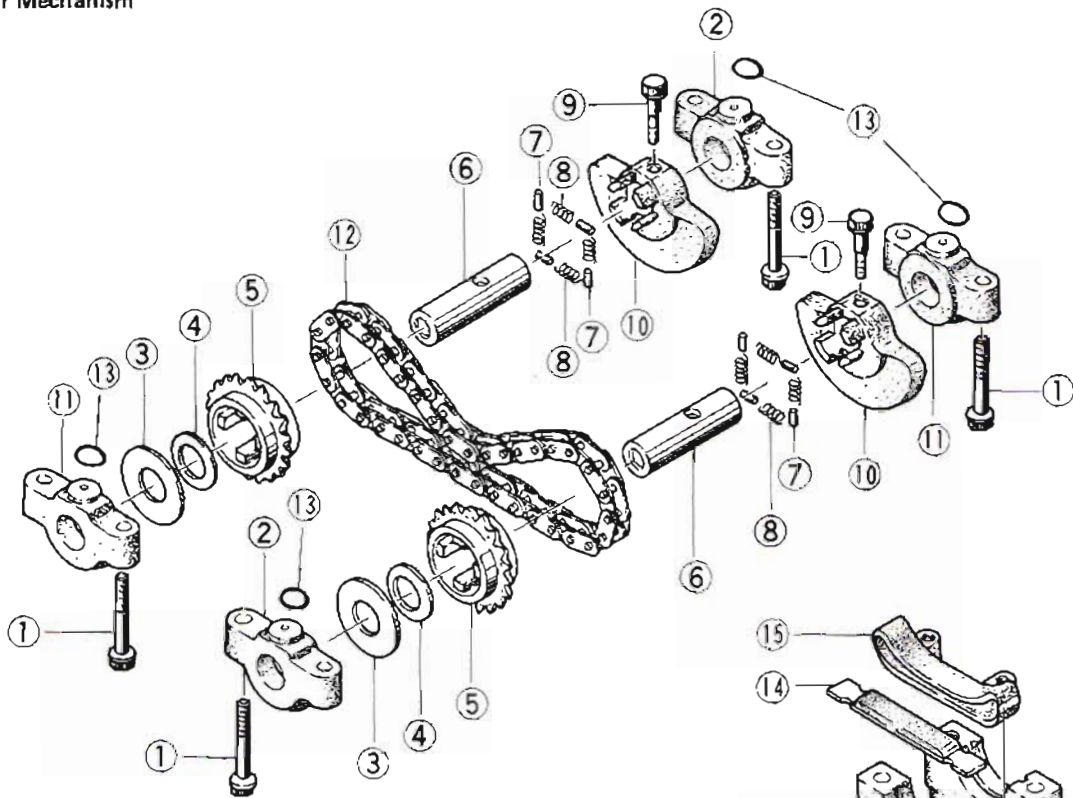

- |                         |                            |
|-------------------------|----------------------------|
| 1. Bolt                 | 11. Holder                 |
| 2. Holder               | 12. Balancer Chain         |
| 3. Shim                 | 13. O Ring                 |
| 4. Shim                 | 14. Chain Guide            |
| 5. Sprocket             | 15. Chain Guide            |
| 6. Balancer Shaft       | 16. Crankshaft Bearing Cap |
| 7. Pin                  | 17. Screw                  |
| 8. Spring               | 18. Bolt                   |
| 9. Balancer Weight Bolt | 19. Bolt                   |
| 10. Balancer Weight     |                            |

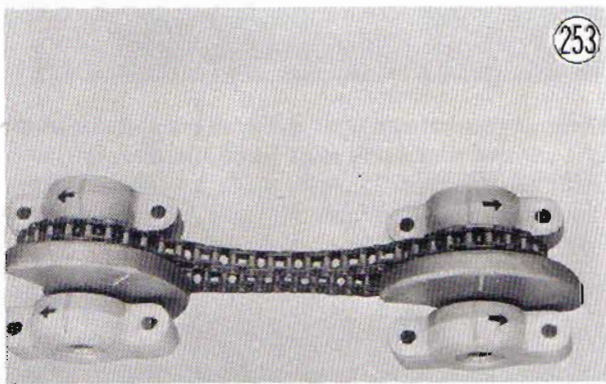

253

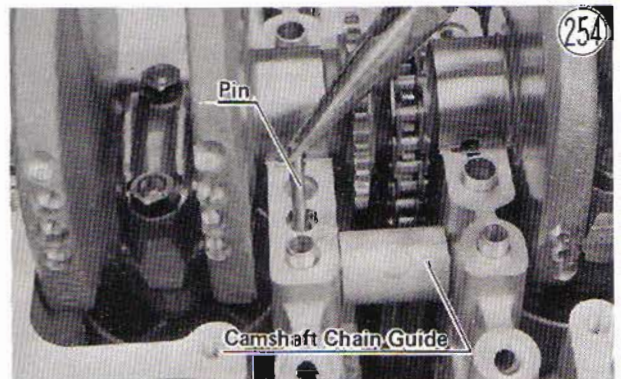

254

## CRANKSHAFT, CAMSHAFT CHAIN

### Removal:

- Remove the transmission (Pg. 55).
- Remove the balancer mechanism (Pg. 64).
- Remove any balancer mechanism holder O rings which are loose.
- Remove the pin which holds the camshaft chain guide pin in place.

- Replace the crankshaft bearing cap with its arrow pointing to the front, and tighten its bolts (4).
- Remove the drive shaft set ring and output shaft set ring.
- Turn the engine right side up.
- Remove the spark plugs.
- Remove the stud nuts (8), and pull off the cylinder head cover. The cover has four O rings.
- Remove the chain tensioner cap and O ring.

- Remove the chain tensioner screws, and pull out the entire tensioner assembly.

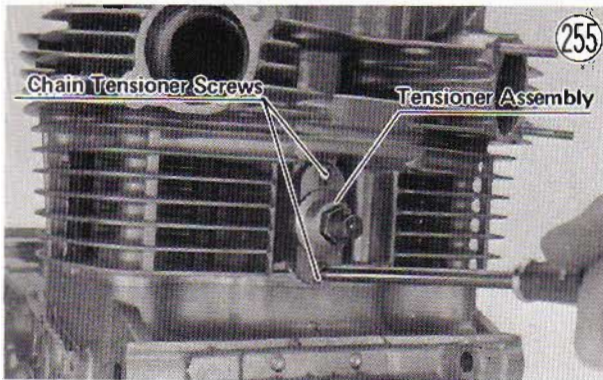

- Fit the timing advancer in place, and tighten its bolt.
- Remove the camshaft sprocket bolts (2). Use a 17 mm wrench to turn the crankshaft.
- Pull the sprocket off its position on the camshaft, slip the chain off the sprocket, and remove the camshaft and sprocket.
- Lift off the cylinder head and cylinder block assembly.
- Remove one of the piston pin snap rings from each piston.



- Remove each piston by pushing the piston pin out the side the snap ring was removed. Use the piston pin puller and adapter "B" (special tools) if necessary.

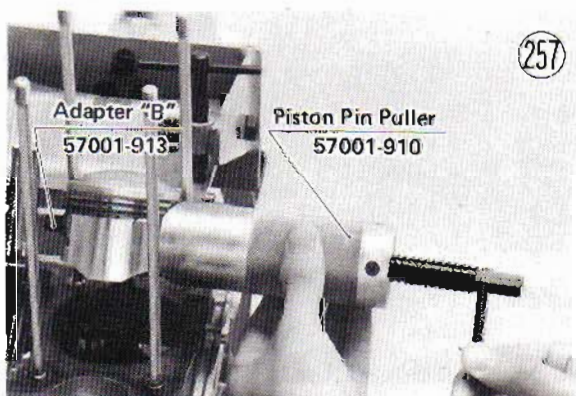

- Remove the timing advancer.
- Turn the upper crankcase half upside down.
- Remove the bolts (4), and take off the crankshaft bearing cap.

- Lift off the crankshaft, and remove the camshaft chain and the oil seal.

**Installation:**

- Check to see that all crankshaft plain bearings (4) are in place, and daub a little engine oil on each bearing.
- Check that the wire band in the crankshaft oil seal has not slipped out of its proper position.
- Fit the camshaft chain back on the lower camshaft sprocket, place the oil seal on the dynamo end of the crankshaft with the wire band side facing in, and set the crankshaft back in its place on the upper crankcase half. The ridge on the oil seal must fit in its crankcase groove.

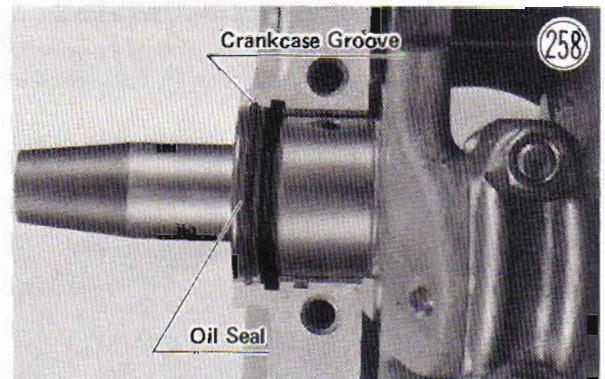

- Replace the crankshaft bearing cap with its arrow pointing to the front, and tighten its bolts (4).
- Turn the upper crankcase half right side up.
- Apply a little oil to the piston pins, and replace both pistons and piston pins. The arrow on the top of each piston must point towards the front.

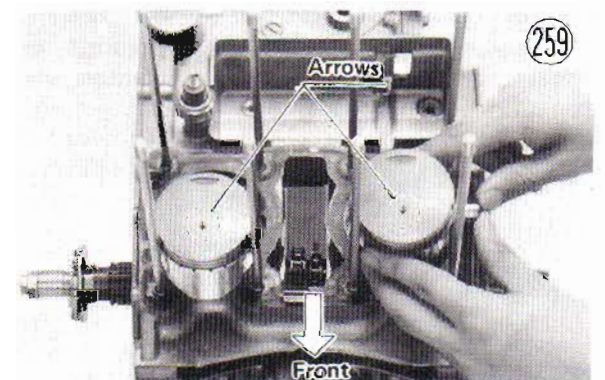

- Fit a new piston pin snap ring into the side of each piston.
- Fit the timing advancer on the end of the crankshaft, and tighten its bolt.
- Apply a small amount of oil to the piston rings and the inside of each cylinder.
- Replace any of the cylinder base gasket or oil passage O rings for a new one if deteriorated or damaged.
- Fit a piston base (special tool) on the crankcase opening for each piston, and turn the crankshaft using a 17 mm wrench such that each piston is situated squarely on its piston base.

## 68 DISASSEMBLY

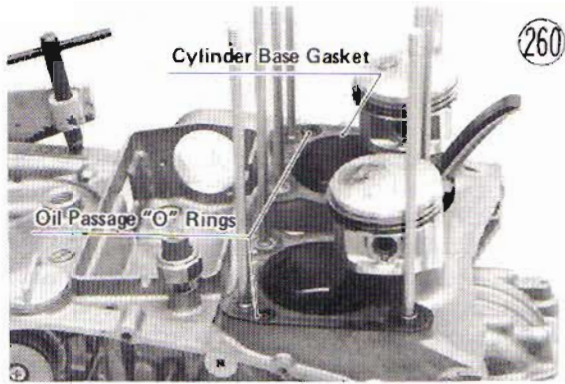

- Compress the piston rings using the piston ring compressor and adapter "A" (special tools) for each piston.



- Replace the cylinder block O rings for a new one if it is deteriorated or damaged.
- Pull out the camshaft chain, and let it hang over the side of the crankcase.
- Fit the cylinder head and cylinder block assembly on the crankcase studs, guide the front camshaft chain guide inside the block, and rest the bottom of the cylinders on the piston ring compressors.

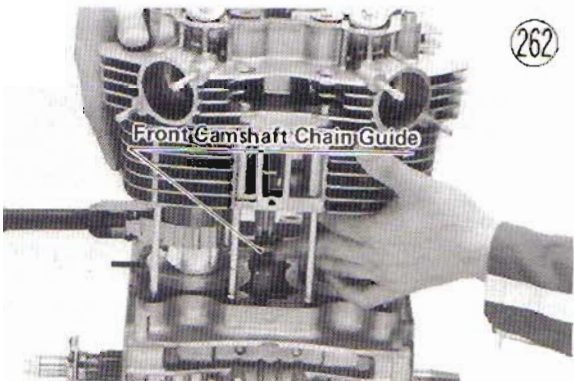

- Lift up the camshaft chain, use a screwdriver to keep the chain from falling down into the cylinder block.

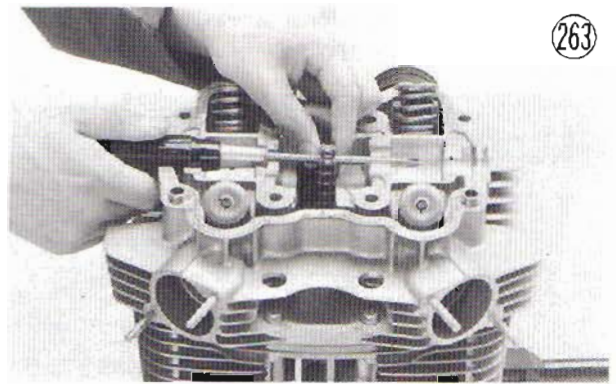

- Work the bottom of each cylinder past the rings, and set the assembly in place while removing the special tools.
- Place the cylinder head holding plate (special tool) on both sides of the cylinder head, and tighten both in place using the stud nuts (8).

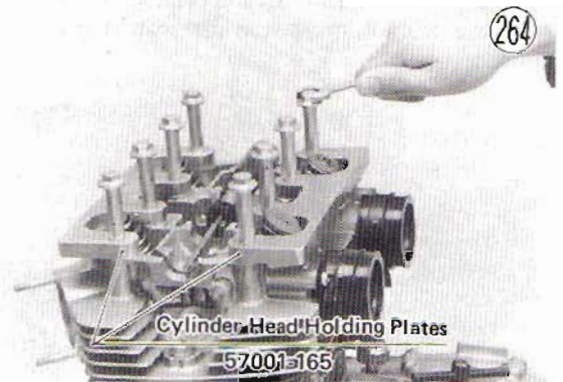

- Set the sprocket on the camshaft near where it fits. The arrowed side of the sprocket faces the right side of the engine.

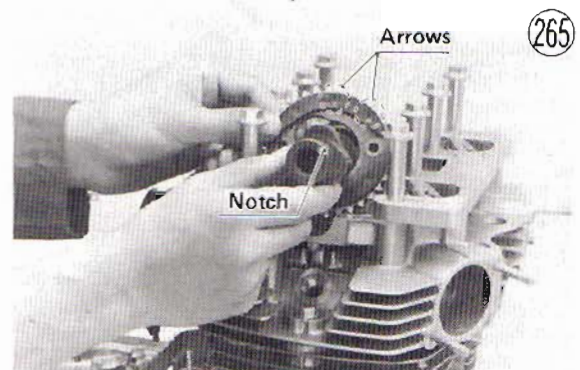

- Run the camshaft through the camshaft chain from the right side of the engine.

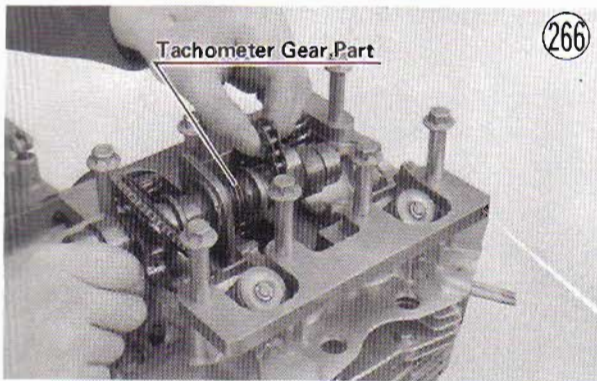

- Turn the crankshaft to where the timing advancer "T" mark (the line adjoining the "T") is directly up. Next, turn the crankshaft counterclockwise exactly  $90^\circ$  ( $\frac{1}{4}$  turn). At this point the "T" mark should align with the upper crankcase half fitting surface.

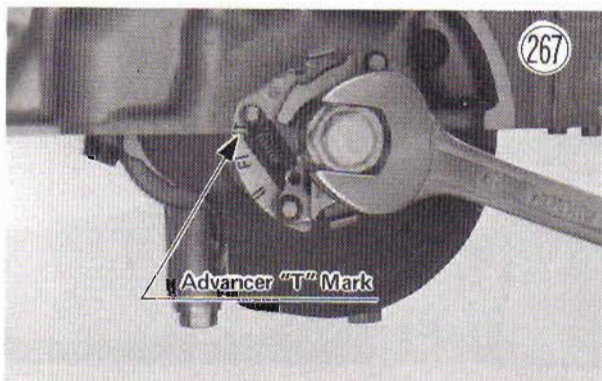

- Turn the camshaft until the notch on the right end faces directly up.

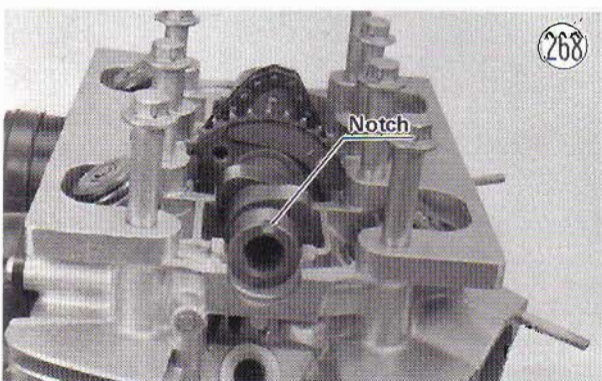

- Turn the sprocket such that the arrow which has no letter adjoining it points to the front of the engine (points parallel to the cylinder head fitting surface), and fit the chain on the sprocket.

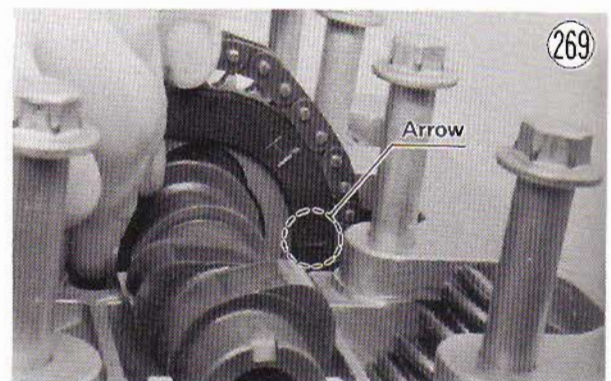

- Fit the sprocket up into place (the bolt holes will not be aligned at this time), and turn the crankshaft while holding the camshaft steady such that the bolt holes align.
- Apply a non-permanent locking agent to one of the sprocket bolts, and replace and tighten it with  $1.4 \sim 1.6 \text{ kg-m}$  ( $10 \sim 11.5 \text{ ft-lbs}$ ) of torque.
- Check that the timing advancer "T" mark and the sprocket arrow are still properly positioned.

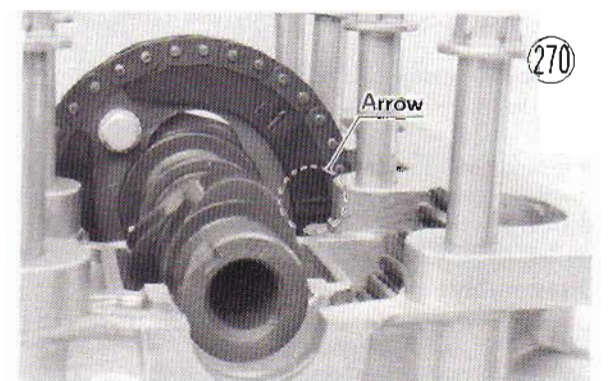

- Turn the crankshaft  $180^\circ$ , and replace the other sprocket bolt. Use a non-permanent locking agent, and tighten with  $1.4 \sim 1.6 \text{ kg-m}$  ( $10 \sim 11.5 \text{ ft-lbs}$ ) of torque.
- Remove the stud nuts (8), and remove the cylinder head holding plates.
- Remove the tachometer gear and the cylinder head cover caps (2) from the cylinder head cover.
- Turn the crankshaft to where the timing advancer "T" mark is directly up.
- Apply liquid gasket to the cylinder head cover O ring fitting surface if necessary to hold the O ring to the cylinder head cover. Check that all O rings (4) are in place.
- Place the cylinder head cover on the cylinder head, and replace the nuts (8). Tighten them in the sequence shown in Fig. 271, tightening first each nut to  $1.5 \text{ kg-m}$  ( $11 \text{ ft-lbs}$ ) of torque and then to  $2.5 \sim 3.0 \text{ kg-m}$  ( $18 \sim 22 \text{ ft-lbs}$ ).
- Check to see that the 8 mm cylinder head bolts are at  $2.5 \sim 3.0 \text{ kg-m}$  ( $18 \sim 22 \text{ ft-lbs}$ ) of torque and the 6 mm bolts at  $1.1 \sim 1.3 \text{ kg-m}$  ( $9.5 \sim 11.3 \text{ ft-lbs}$ ).

## 70 DISASSEMBLY

### Cylinder Head & Cylinder Head Cover Tightening Order

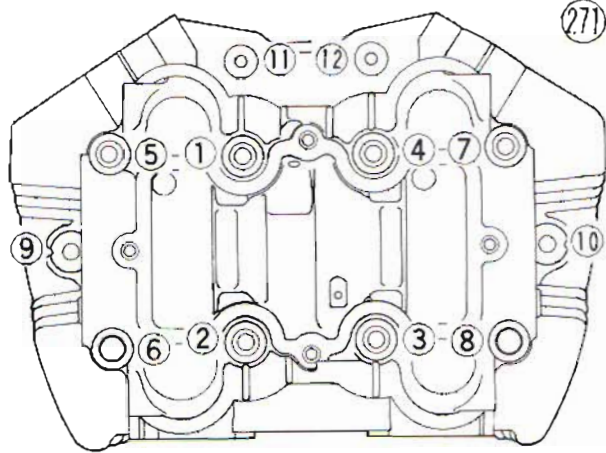

- Apply a small amount of heat durable grease to the tachometer gear, and replace the tachometer gear and the cylinder head cover caps.
- Replace the tensioner assembly. The sequence is push rod, spring, gasket, holder, push rod guide, and lock nut. Tighten its screws, adjust it (Pg. 15), and replace the cap and O ring.
- Replace the spark plugs.
- Turn the engine upside down.
- Replace the drive shaft set ring and output shaft set ring.
- Remove the crankshaft bearing cap.
- Replace the pin which holds the camshaft chain guide pin in place.
- Replace the balancer mechanism holder O rings which were removed.
- Install the balancer mechanism (Pg. 64).
- Install the transmission (Pg. 57).

#### Disassembly:

- Remove the nuts (4) and con-rods (2). Each con-rod has a plain bearing in its big end.

#### Assembly Notes:

1. Fit the con-rod big end together so that the marks align.

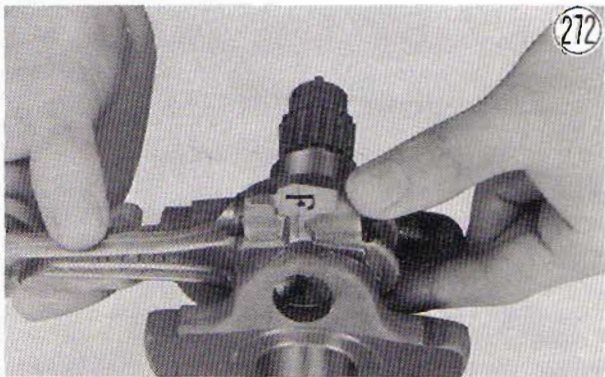

2. Tighten the nuts with 3.3 ~ 3.7 kg-m (24 ~ 27 ft-lbs) of torque.
3. If a new con-rod is installed, use a "1" con-rod for a "1" crankshaft and an unnumbered one for an unnumbered crankshaft (Fig. 273).

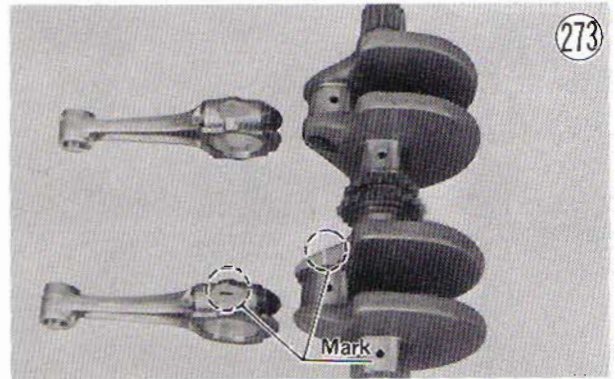

### CAMSHAFT CHAIN GUIDE (FRONT)

#### Removal:

- Remove the crankshaft (Pg. 66).
- Push the pin out, and remove the guide.

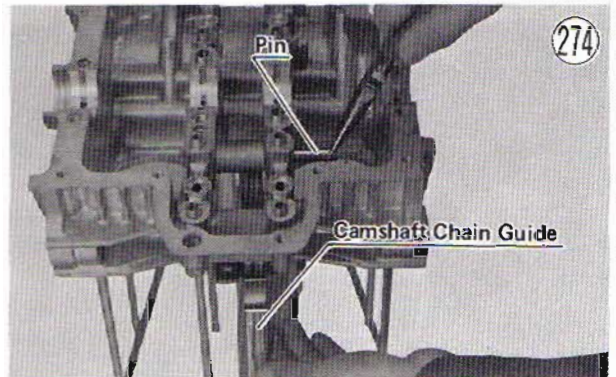

#### Assembly Note:

- The grooved end of the pin goes to the dynamo side.

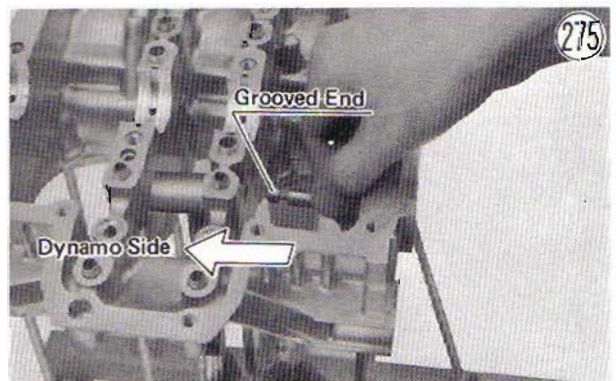

### CAMSHAFT CHAIN GUIDE (REAR)

#### Removal:

- Remove the cylinder block (Pg. 39).

- Remove the camshaft chain guide upper pin, and remove the guide.

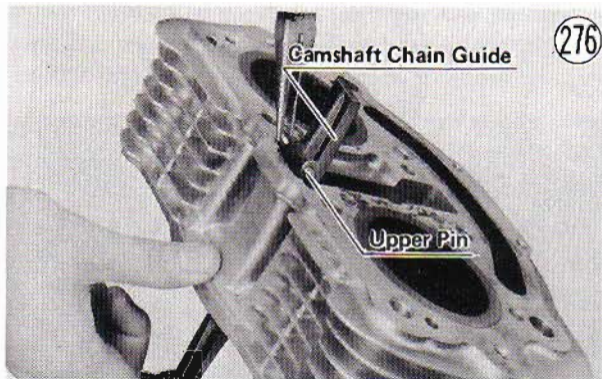

## FRONT WHEEL

### Removal:

- Put the motorcycle up on its center stand, and jack or prop up the engine so that the front wheel will be off the ground.
- Remove the front axle clamp nuts (2), lock washers (2), and clamp.
- Remove the axle cotter pin, nut, and washer.
- Holding the wheel to facilitate axle removal, pull out the axle, and then remove the wheel from the motorcycle. The speedometer gear housing easily separates from the hub.

### Installation:

- With the speedometer cable running above the fender stay, fit the speedometer gear housing into the hub, hold the front wheel in its place between the front shock absorbers, and insert the axle from the disc side.



- Replace the axle washer and nut. Tighten the axle nut with 10~13 kg-m (72~94 ft-lbs) of torque while making sure that the speedometer gear housing does not move out of its proper position.
- Install a new axle cotter pin.
- Replace the axle clamp, lock washers, and nuts. The front end of the clamp is the one which fits squarely on the bottom of the fork outer tube (the arrow points to the front). Tighten first the front nut and then the rear with 1.8~2.0 kg-m (13~14.5 ft-lbs) of torque.

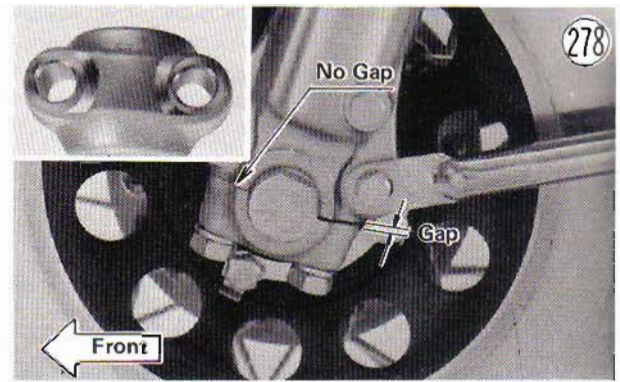

### Speedometer Gear Housing Disassembly:

- Disconnect the lower end of the speedometer cable with pliers.
- Pull out the speedometer gear (8) with close-in circlip pliers or some other suitable tool.

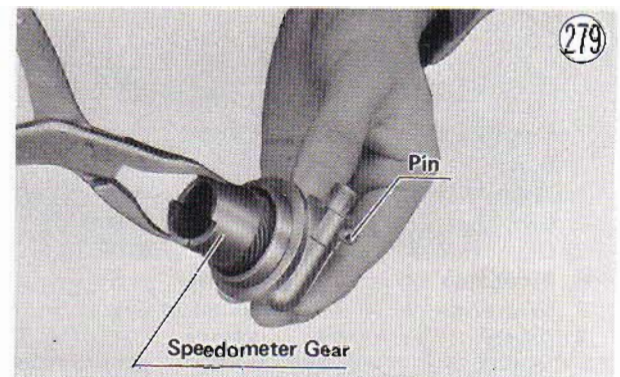

- To remove the speedometer gear bush or speedometer pinion, first drill out the pin in the speedometer gear housing.

### Speedometer Gear Housing Assembly Notes:

- Regrease the speedometer gear (Pg. 132).
- Insert the speedometer inner cable into the housing while turning the gear so that the slot in the end of the cable will seat in the tongue of the speedometer pinion.

### Front Hub Disassembly:

- Straighten back the part of the disc double washers (3) that are bent over the disc bolts (2), remove the bolts (4) and double washers (2), and pull off the disc (5).
- Pull off the cap (4) on the disc side of the hub.
- Pull out the grease seal (7) on the disc side using a hook, and remove the circlip (8).
- Insert a metal rod into the hub from the speedometer gear side, and remove the bearing (9) on the disc side by tapping evenly around the bearing inner race.

## 72 DISASSEMBLY

### Front Hub

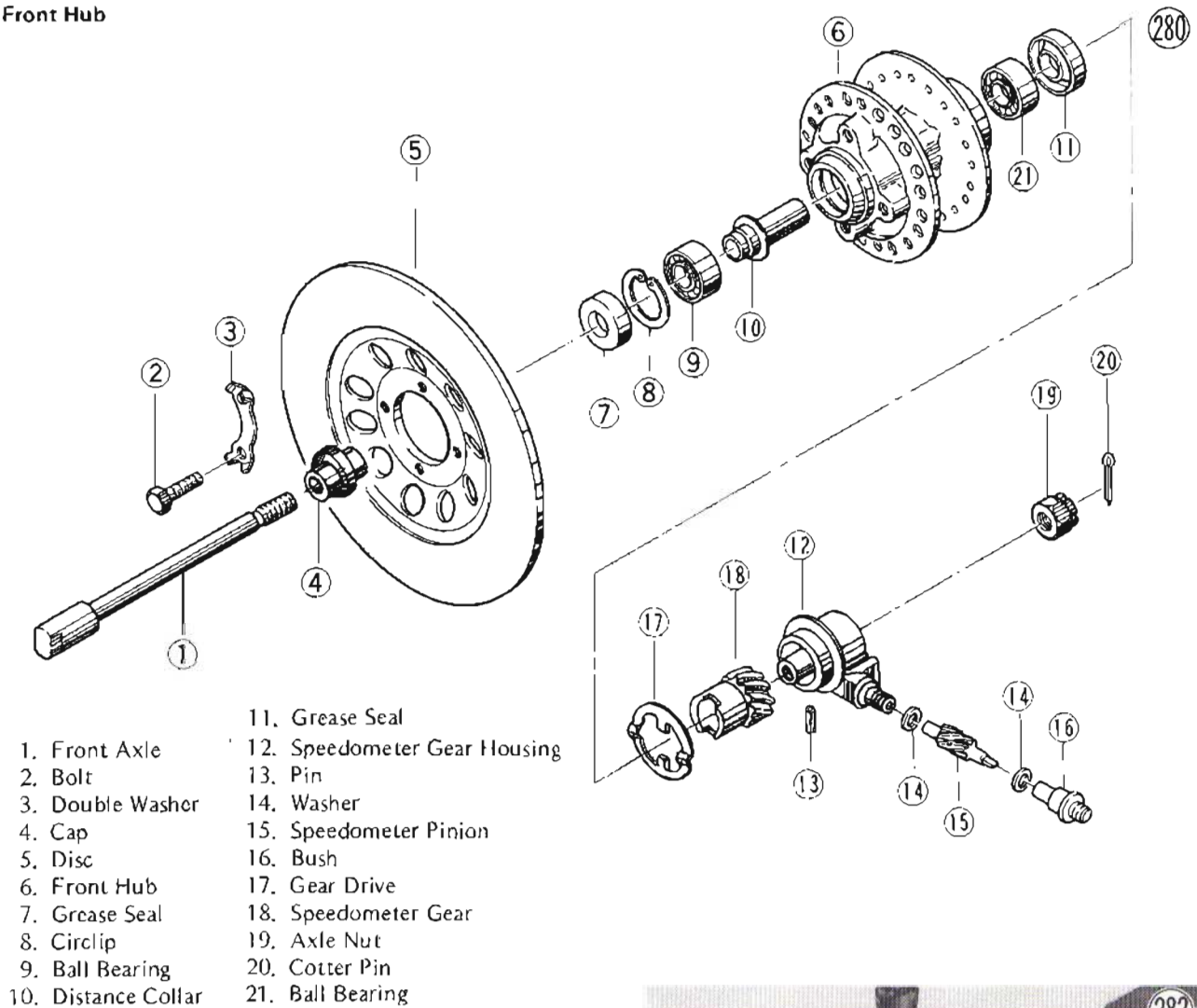

- |                     |                              |
|---------------------|------------------------------|
| 1. Front Axle       | 11. Grease Seal              |
| 2. Bolt             | 12. Speedometer Gear Housing |
| 3. Double Washer    | 13. Pin                      |
| 4. Cap              | 14. Washer                   |
| 5. Disc             | 15. Speedometer Pinion       |
| 6. Front Hub        | 16. Bush                     |
| 7. Grease Seal      | 17. Gear Drive               |
| 8. Circlip          | 18. Speedometer Gear         |
| 9. Ball Bearing     | 19. Axle Nut                 |
| 10. Distance Collar | 20. Cotter Pin               |
|                     | 21. Ball Bearing             |



- Remove the remaining grease seal (7) using a hook, and pull out the speedometer gear drive (17).
- Insert the metal rod into the hub from the disc side, and remove the other bearing (9) by tapping evenly around the bearing inner race. The distance collar (10) will come out with the bearing.

#### Front Hub Assembly Notes:

1. Inspect the bearings and replace if necessary (Pg. 132). Install them using the wheel bearing driver "A" and the bearing driver holder (special tools).

2. Replace the grease seals for new ones using a press or wheel bearing driver "A" (special tool).
3. Tighten the disc bolts (4) with 1.6 ~ 2.2 kg-m (11.5 ~ 16 ft-lbs) of torque, bend the washer tabs back over the disc bolts.
4. Clean off completely any grease that has gotten on either side of the disc with a high flash point solvent of some kind. Do not use one which will leave an oily residue.

#### REAR WHEEL

##### Removal:

- Put the motorcycle up on its center stand.

- Take out the clip from the rear torque link bolt, remove the nut and lock washer, and free the torque link from its bolt.
- Being careful not to bend or otherwise damage it, free the rear brake light switch spring from the tab on the brake pedal.



- Remove the adjusting nut from the end of the brake rod, and then free the rod from the cam lever by depressing the brake pedal. Remove the brake rod spring and joint.

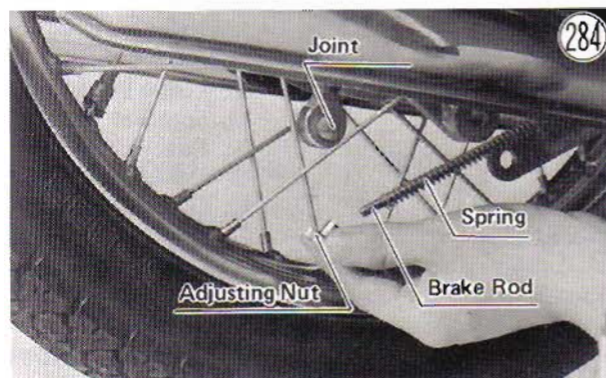

- Take out the cotter pin, remove the axle nut and washer, and pull out the axle.
- Remove the axle sleeve from the right side of the wheel.
- Slide the wheel out of the wheel coupling and then free from the motorcycle.

#### Installation:

- Check to see that the torque link bolt is in place in the brake panel, and slip the wheel back into the coupling.
- Replace the axle sleeve.
- Slide the axle through the hub from the left to the right.
- Fit the torque link onto its bolt, and replace its lock washer and nut.
- Tighten the torque link nut with 2.7 ~ 3.0 kg-m (19.5 ~ 22 ft-lbs) of torque, and replace its clip.
- Replace the axle washer and nut, tightening the nut to 13 ~ 16 kg-m (94 ~ 116 ft-lbs) of torque.
- Install a new axle cotter pin.
- Replace the joint into the end of the cam lever and the spring on the end of the brake rod.
- Fit the rod through the joint, and screw on the adjuster.

- Carefully fit the rear brake light switch spring back into the tab on the brake pedal.
- Adjust the rear brake (Pg. 18), and check the rear brake light switch adjustment (Pg. 19).

#### Rear Brake Disassembly:

- Remove the brake panel (30) from the wheel.
- Mark the position of the cam lever (13) on the camshaft (10) so that it can later be installed at the same angle.

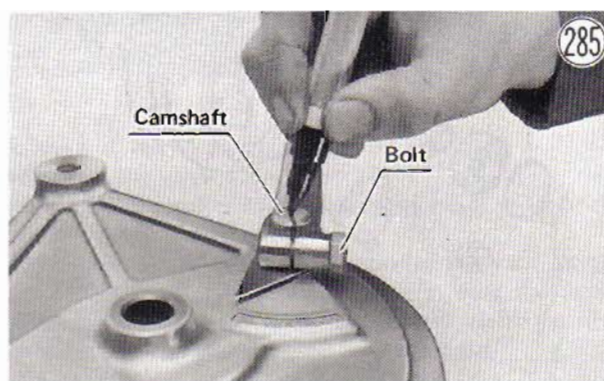

- Remove the cam lever, brake lining wear indicator (12), and gasket (11).
- Pull out the cotter pins (6) (2), and take off the double washer (7).
- Using a clean cloth around the linings if necessary to prevent grease or oil from getting on the linings, pull the brake shoes (8), spring (9), and camshaft as an assembly off the brake panel.

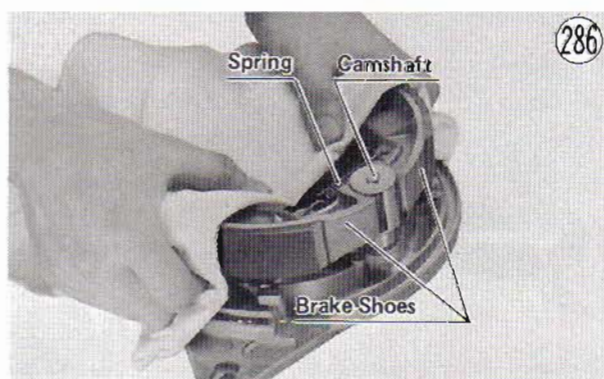

- Twist the brake shoes as shown in Fig. 288 to separate the camshaft from the shoes.

## 74 DISASSEMBLY

### Rear Hub

1. Axle
2. Bearing
3. Distance Collar
4. Shock Damper Rubber
5. Bearing
6. Cotter Pin
7. Double Washer
8. Brake Shoe
9. Spring
10. Camshaft
11. Gasket
12. Brake Lining Wear Indicator
13. Cam Lever
14. Bolt
15. Axle Sleeve
16. Washer

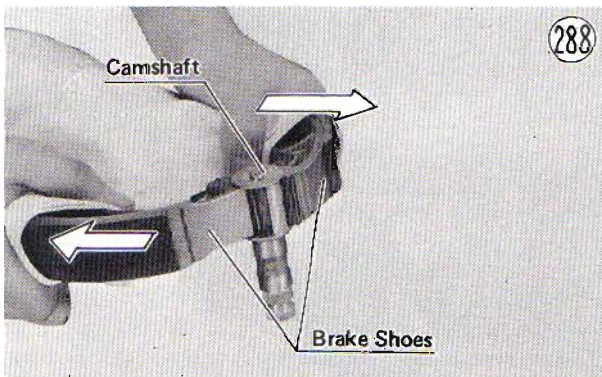
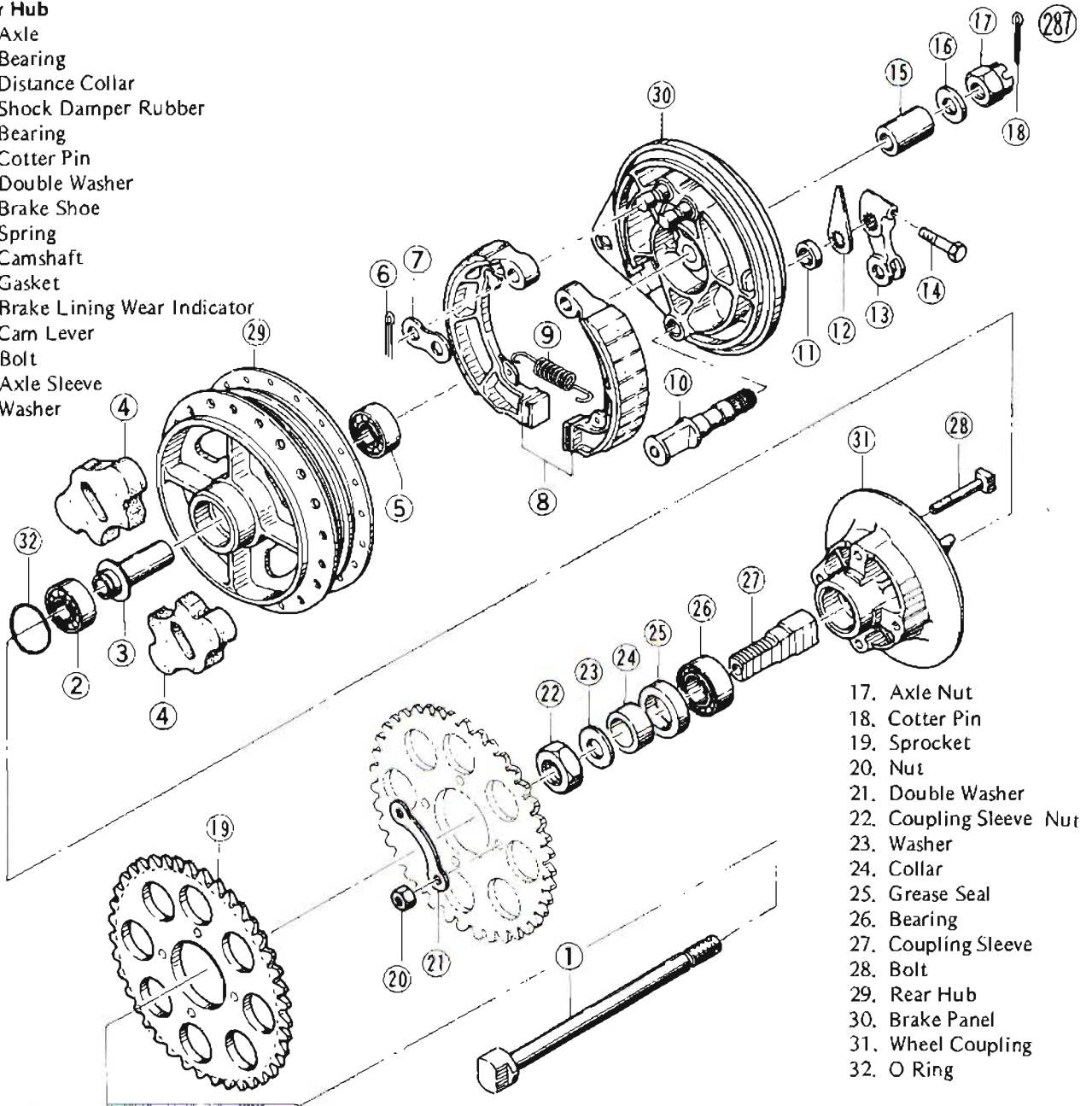

- Remove the spring to separate the brake shoes.

### Rear Brake Assembly:

- Clean the old grease from the camshaft, and regrease

using regular cup grease. Apply grease to the center of the shaft and on the cam surfaces. Do not over-grease.

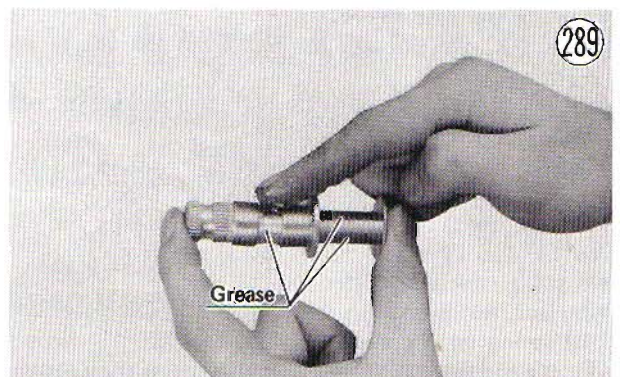

- Install the spring connecting the brake shoes.
- Wrapping a clean cloth around the linings if necessary to prevent grease or oil from getting on the linings, fit the camshaft between the brake shoes, and then fit the assembly back onto the brake panel.
- Replace the double washer (7) on the anchor pins, and install new cotter pins (6) (2).
- Fit the gasket on the camshaft.
- Replace the brake lining wear indicator so that it points just to the right of the "E" in RANGE.



- Replace the cam lever into its original position on the camshaft, and tighten its bolt.
- Check to see that the torque link bolt is in place in the panel, and fit the panel back into the wheel.

#### Rear Hub Disassembly:

- Pull off the brake panel (30).
- Insert a metal rod into the hub, and remove the bearing (2) on the other side by tapping evenly around the bearing inner race. The distance collar (3) will come out with the bearing.
- Insert the metal rod into the hub from the other side, and remove the remaining bearing (5) by tapping evenly around the bearing inner race.

#### Rear Hub Assembly Notes:

1. Inspect the bearings and replace if necessary (Pg.132 ). Install them using the wheel bearing driver "C" and the bearing driver holder (special tools).

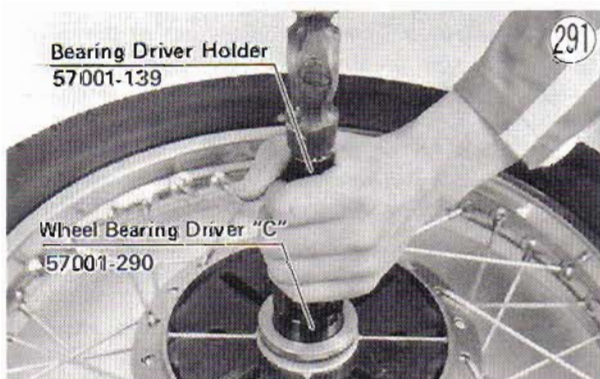

2. Inspect the O ring and replace if necessary.

#### TIRE, TUBE

##### Removal:

- Remove the wheel from the motorcycle (Pg. 71 or 72).
- Mark the valve stem position on the tire with chalk so that the tire will not get turned and upset wheel balance.

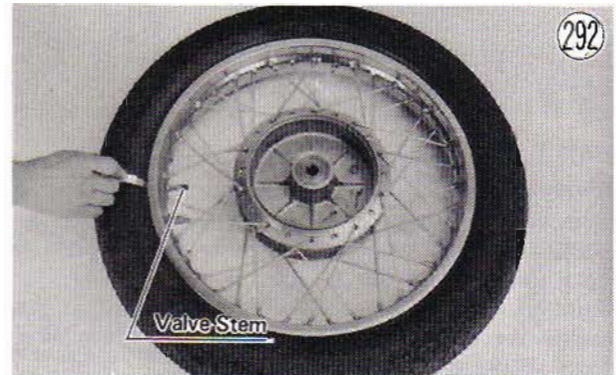

- Take out the valve core to let out the air.
- Remove the valve stem nut.
- Use a rubber mallet to break the tire beads away from both sides of the rim.
- Step on the side of the tire opposite the valve stem, and start prying the tire off the rim near the valve stem with tire irons. Take care not to insert the tire irons so deeply that the tube gets damaged.

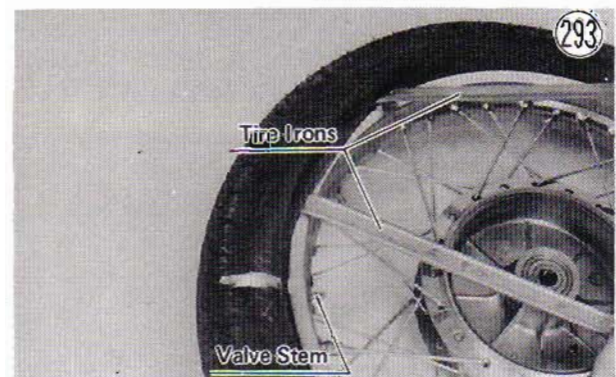

- Remove the tube when one side of the tire is pried off.
- Pry the tire off the rim.

##### Installation:

- Put just enough air in the tube to keep it from getting caught between the tire and rim, and insert it into the tire at this point, even if the tire was completely removed from the rim. Insert the valve stem into the rim, and screw the nut on loosely.
- If the tire was completely removed, pry one side back onto the rim. Align the chalk mark on the tire with the valve stem.
- Pry the other side of the tire onto the rim, starting at the side opposite the valve. Take care not to insert to the tire irons so deeply that the tube gets damaged.

## 76 DISASSEMBLY

- Check that the tube is not pinched between the tire and rim, and then inflate to the standard pressure (Pg. 128).
- Tighten the valve stem nut, and put on the valve cap.
- Balance the wheel (Pg. 17).
- Mount the wheel back onto the motorcycle (Pg. 71 or 73).

### RIM

#### Removal:

- Remove the wheel from the motorcycle (Pg. 71 or 72).
- Take the tire and tube off the rim (Pg. 75).
- Tape or wire all the spoke intersections so that the spokes don't get mixed up, and unscrew the nipples from all the spokes with a screwdriver.

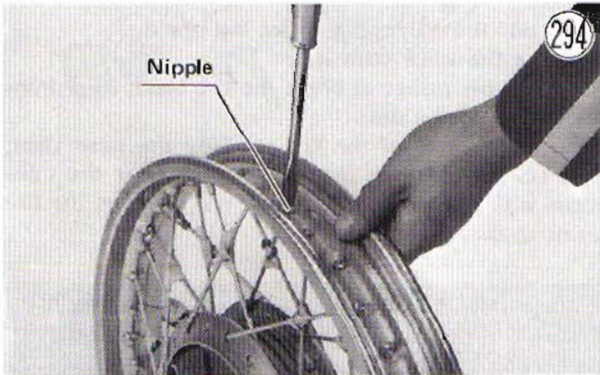

#### Installation:

- Fit all the spokes through the holes, and screw all the nipples onto the spokes tightening them partially.
- Suspend the wheel by the axle, and set up a dial gauge to measure rim runout.

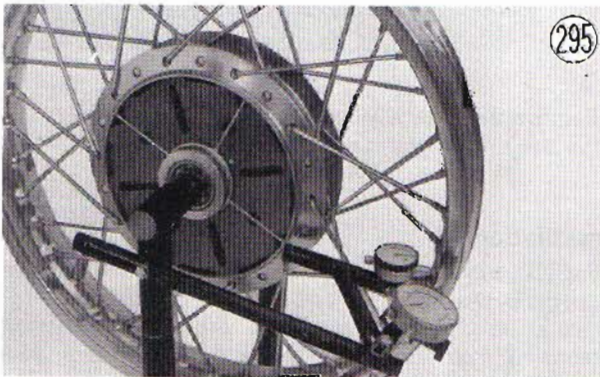

- Tighten the spokes evenly so that the radial (out from the axle) runout is less than 2 mm and the axial (side to side) runout is less than 3 mm.
- Make sure that the spokes are tightened evenly. Standard torque is 0.25 ~ 0.3 kg-m (22 ~ 26 in-lbs).

- Mount the tube and tire (Pg. 75).
- Balance the wheel (Pg. 17).
- Mount the wheel back onto the motorcycle (Pg. 71 or 73).

### SPOKE (breakage replacement)

- Reduce the tire air pressure by a small amount.
- Insert the new spoke through the hub, and bend it to meet the nipple.

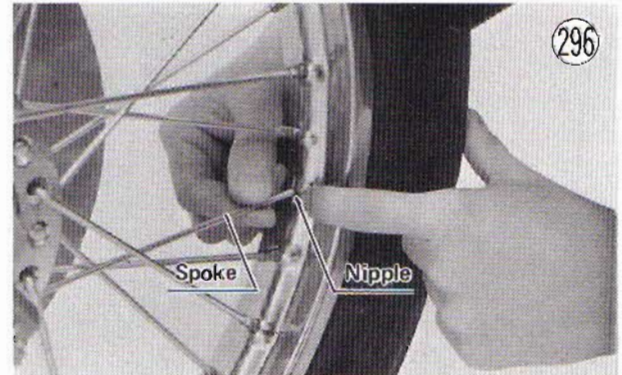

- Tighten with a spoke wrench. Standard torque is 0.25 ~ 0.3 kg-m (22 ~ 26 in-lbs).
- Inflate the tire to standard pressure (Pg. 128).

### DISC BRAKE

Removal, installation, disassembly, and assembly of the disc brake is divided up as follows:

Pad Removal	Caliper Assembly
Pad Installation	Master Cylinder Removal
Disc Removal	Master Cylinder Installation
Disc Installation Note	Notes
Caliper Removal	Master Cylinder Disassembly
Caliper Installation Note	Master Cylinder Assembly
Caliper Disassembly	Notes

Before working on the disc brake, take special note of the following:

#### CAUTION

1. Except for the disc pads and disc, use only disc brake fluid, isopropyl alcohol, or ethyl alcohol for cleaning brake parts. Do not use any other fluid for cleaning these parts. Gasoline, motor oil, or any other petroleum distillate will cause deterioration of the rubber parts. Oil spilt on any part will be difficult to wash off completely, and will eventually reach and break down the rubber used in the disc brake.
2. When handling the disc pads or disc, be careful that no disc brake fluid or any oil gets on them. Clean off any fluid or oil that inadvertently gets on the pads or disc with a high flash point solvent of some kind. Replace the pads for new ones if they cannot be cleaned satisfactorily.
3. Brake fluid quickly ruins painted surfaces; any spilt fluid should be completely wiped up immediately.
4. If any of the brake line fittings or the bleed valve is opened at any time, **AIR MUST BE BLED FROM THE BRAKE** (Pg. 137).

5. When installing or assembling the disc brake, tighten the disc brake fittings to the values given in Table 1. Improper torque may cause the brake to malfunction.

Table 1 Disc Brake Torque

Brake lever	0.5~0.7 kg-m	43~61	in-lbs
Brake lever adjuster lock nut	1.8~2.3 kg-m	13.0~16.5	ft-lbs
Master cylinder clamp	0.6~0.9 kg-m	52~78	in-lbs
Fitting (banjo) bolts	2.5~3.3 kg-m	18.0~24	ft-lbs
Brake pipe nipple	1.7~1.8 kg-m	12.0~13.0	ft-lbs
3-way joint	0.5~0.6 kg-m	43~52	in-lbs
Front brake light switch	1.5~2.0 kg-m	11.0~14.5	ft-lbs
Caliper shafts	3.0~3.6 kg-m	22~26	ft-lbs
Caliper mounting bolts	2.5~3.3 kg-m	18.0~24	ft-lbs
Bleed valve	0.8~1.0 kg-m	69~87	in-lbs
Disc mounting bolts	1.6~2.2 kg-m	11.5~16.0	ft-lbs

### Pad Removal:

- Remove the front wheel (Pg. 71).
- Take out the mounting screw for pad B, and remove the pad. A lock washer and metal disc also come off.



- After pad B is removed, squeeze the brake lever several times until the piston pushes out pad A.

### Pad Installation:

- Remove the bleed valve cap, open (loosen) the valve slightly, push the piston in by hand as far as it will go, and then close (tighten) the valve. Wipe up any spilled fluid, and recap the bleed valve.

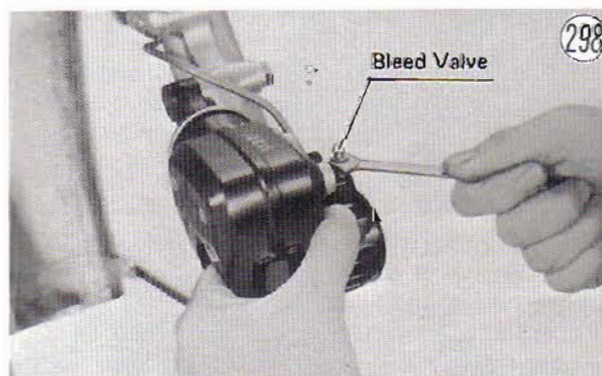

- Fit to the rear of pad A the anti-squeak shim, align the projection of pad A with the slot in the bottom of the caliper, and insert the pad.

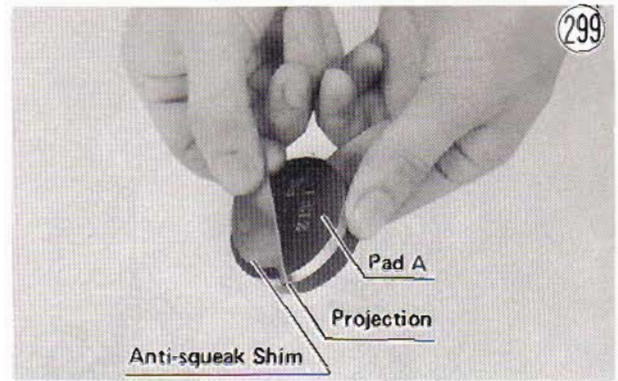

- Install pad B, its metal disc, mounting screw, and lock washer. Use a non-permanent locking agent on the mounting screw.
- Since fluid was spilled when the bleed valve was opened, check the fluid level in the master cylinder.

### Disc Removal:

- Remove the front wheel (Pg. 71).
- Straighten back the portions of the disc double washers (2) that are bent over the disc bolts (1), and remove the bolts (4) and double washers (2).
- Pull off the disc (3).

### Disc Installation Note:

- Tighten the disc bolts with 1.6~2.2 kg-m (11.5~16 ft-lbs) of torque, bend the washer tabs back over the disc bolts.

### Caliper Removal:

- Unscrew the brake pipe from where it connects to the caliper. Cap the end of the pipe to prevent fluid from flowing out.

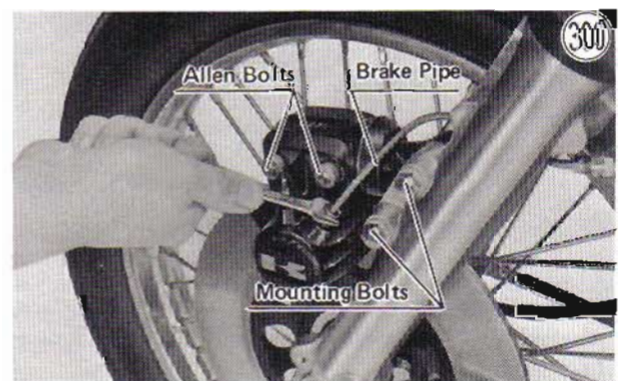

- If the caliper holder is to be removed, loosen the Allen bolts (2) now.
- Remove the mounting bolts (2), each with a flat washer and lock washer, and then take off the caliper.

### Installation Note:

- Bleed the brake line after installation (Pg. 137).

### Caliper Disassembly:

- Cover the caliper opening with clean, sturdy cloth, and remove the piston (2) by applying compressed air to where the brake line fits into the caliper.

## 78 DISASSEMBLY

Disc

301

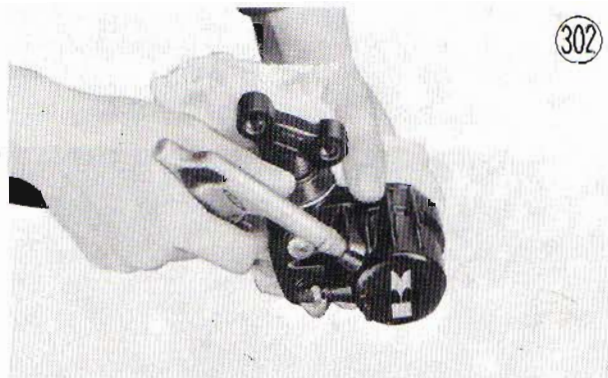
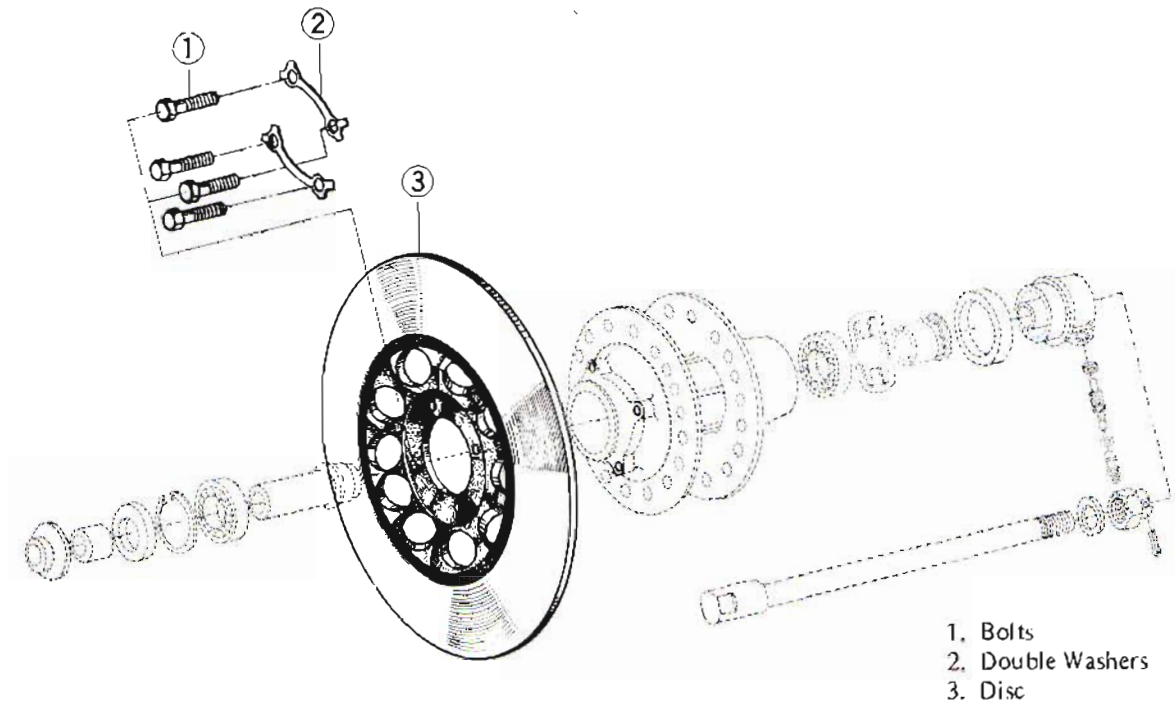

302

- Fit the fluid seal and dust seal in place inside the cylinder.
- Apply brake fluid to the outside of the piston, and press into place with a press, the inside of the piston facing out. Take care that neither the cylinder nor the piston skirt get scratched.

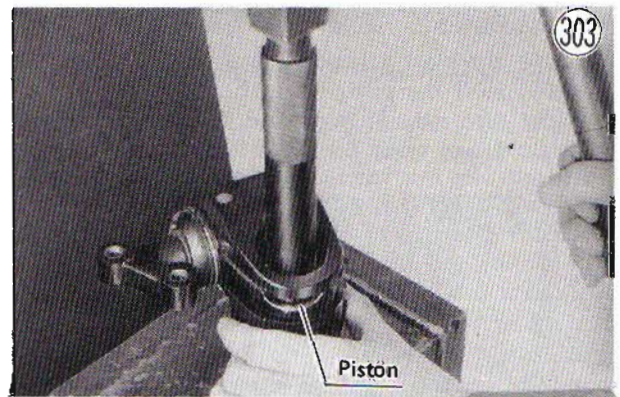

303

- Taking ample care not to damage the cylinder surface, remove the piston dust seal ④ and fluid seal ③ carefully with a hook.
- Remove the caliper holder Allen bolts ⑩ (2).
- Pull out the caliper holder ⑪, and pry off the clip ① and dust cover ⑫.

### Caliper Assembly:

- Clean the caliper parts with brake fluid or alcohol (See CAUTION—Pg. 76).
- Fit the dust cover onto the caliper holder with the outside of its inner lip in the groove on the holder, and then fit the inside of the outer lip into the groove on the caliper. Be sure that the lips fit in place evenly.
- Install the clip.
- With the caliper holder properly positioned, replace and tighten its Allen bolts.

- Fit to the rear of pad A the anti-squeak shim, align the projection of pad A with the slot in the bottom of the caliper, and insert the pad.
- Install pad B, its metal disc, mounting screw, and lock washer. Use a non-permanent locking agent on the mounting screw.

### Master Cylinder Removal:

- Take off the right rear view mirror.
- Pull back the dust cover, and remove the banjo bolt to disconnect the upper brake hose from the master

## Caliper Assembly

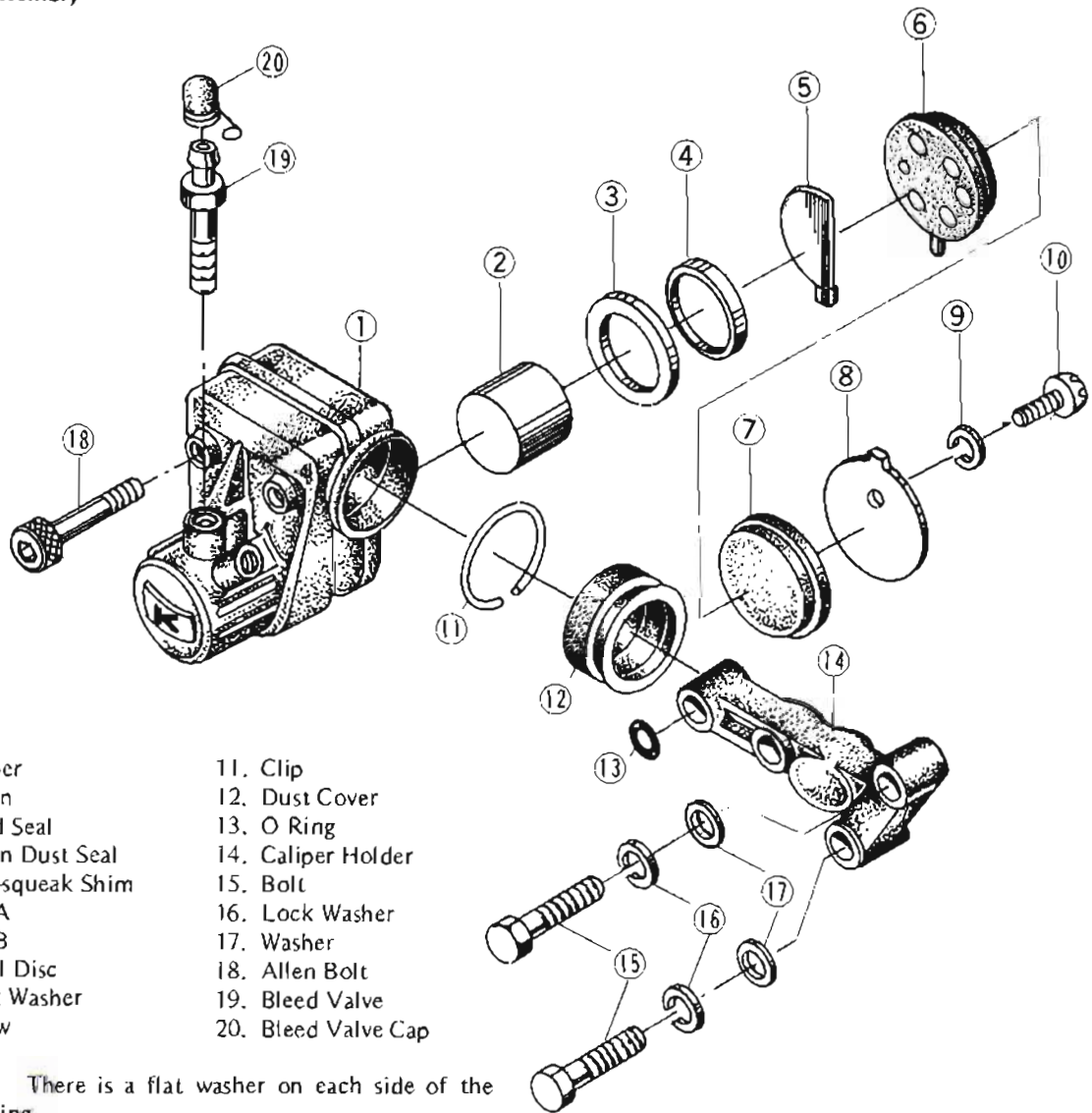

cylinder. There is a flat washer on each side of the hose fitting.

- Remove the clamp bolts (2), and take off the master cylinder. There is a flat washer for each master cylinder clamp bolt. Wipe up immediately any brake fluid that spills.

**Master Cylinder Installation Notes:**

1. The master cylinder clamp is installed with the small projection towards the throttle grip. Tighten first the upper clamp bolt and then the lower clamp bolt, both with 0.6 ~ 0.9 kg-m (46 ~ 78 in-lbs) of torque.

2. Bleed the brake line after master cylinder installation (Pg. 137).

**Master Cylinder Disassembly:**

- Take off the master cylinder cap (1) and diaphragm (3), and empty out the brake fluid.
- Take off the brake lever (4). Use the master cylinder stopper remover (special tool) to remove the dust seal stopper (5), and then remove the dust seal (6).

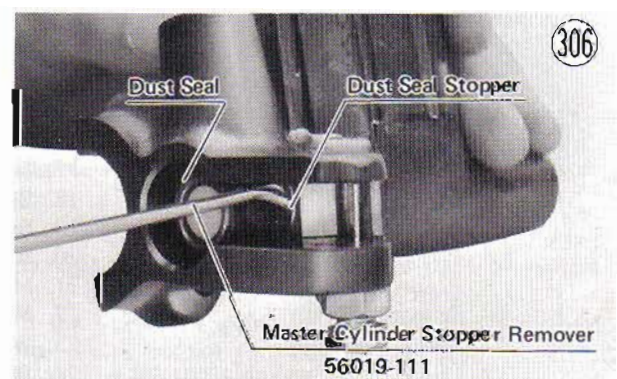
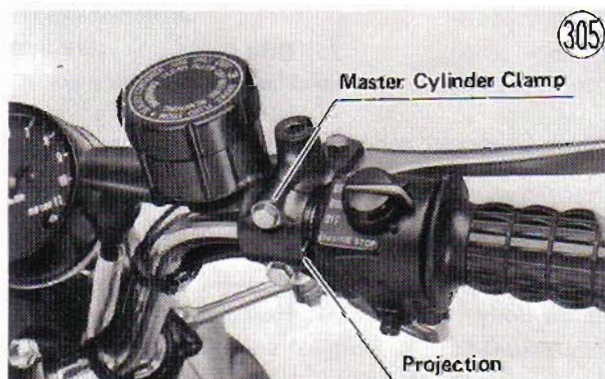

# 80 DISASSEMBLY

Disc Brake

307

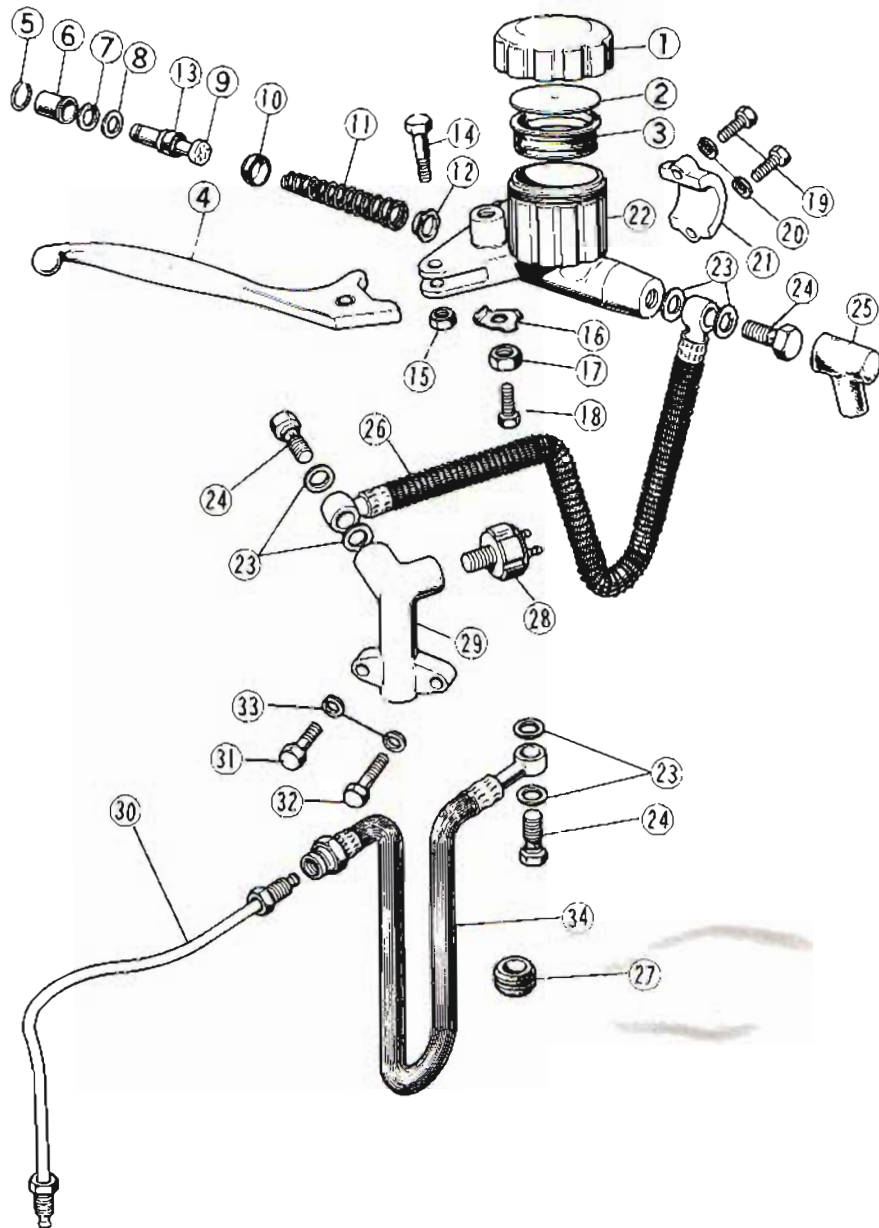

- |                          |                           |                     |
|--------------------------|---------------------------|---------------------|
| 1. Cap                   | 13. Secondary Cup         | 25. Dust Cover      |
| 2. Plate                 | 14. Bolt                  | 26. Hose            |
| 3. Diaphragm             | 15. Nut                   | 27. Grommet         |
| 4. Brake Lever           | 16. Lock Washer           | 28. Pressure Switch |
| 5. Dust Seal Stopper     | 17. Nut                   | 29. 3-Way Fitting   |
| 6. Dust Seal             | 18. Bolt                  | 30. Pipe            |
| 7. Retaining Ring        | 19. Bolt                  | 31. Bolt            |
| 8. Piston Stopper        | 20. Washer                | 32. Bolt            |
| 9. Piston Assembly       | 21. Master Cylinder Clamp | 33. Washer          |
| 10. Primary Cup          | 22. Master Cylinder Body  | 34. Hose            |
| 11. Spring Assembly      | 23. Washer                |                     |
| 12. Check Valve Assembly | 24. Banjo Bolt            |                     |

- Remove the retaining ring (7) with retaining ring pliers (special tool), and take the stopper (8), piston (9), primary cup (10), spring (11), and check valve (12) out of the master cylinder body. Do not remove the secondary cup (13) from the piston since removal would damage the cup.

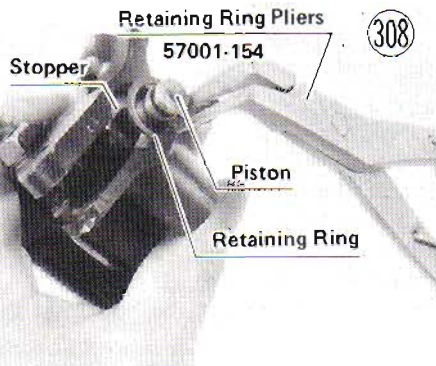

### Master Cylinder Assembly Notes:

1. Before assembly, clean all parts including the master cylinder with brake fluid or alcohol (See CAUTION—Pg. 76), and apply brake fluid to the removed parts and to the inner wall of the cylinder.
2. Be sure that the primary cup and check valve are not installed backwards and that neither is turned sideways after insertion.
3. Use a new retaining ring for assembly, pushing it into place in the cylinder wall groove with the master cylinder ring driver (special tool). Use the same tool for installing the dust seal and dust seal stopper.

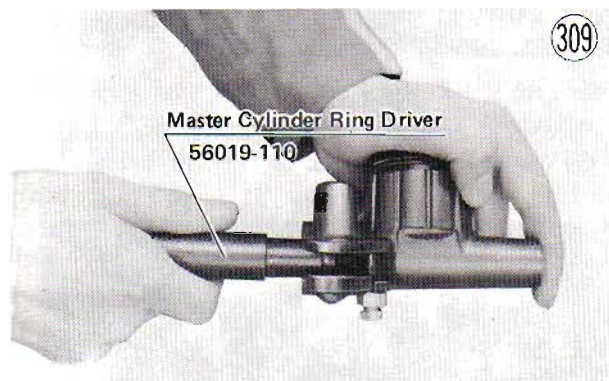

### DRIVE CHAIN

#### Removal:

- A. If the chain is being removed and replaced again for cleaning or engine removal:
  - Check to see that the transmission is in neutral.
  - Take out the shift pedal bolt and remove the shift pedal.
  - Remove the left foot peg bolt, left foot peg, and side stand spring.
  - Remove the engine sprocket cover screws (4), and pull the cover out of place.
  - Remove the clip carefully from the drive chain master link with pliers, and remove the master link.

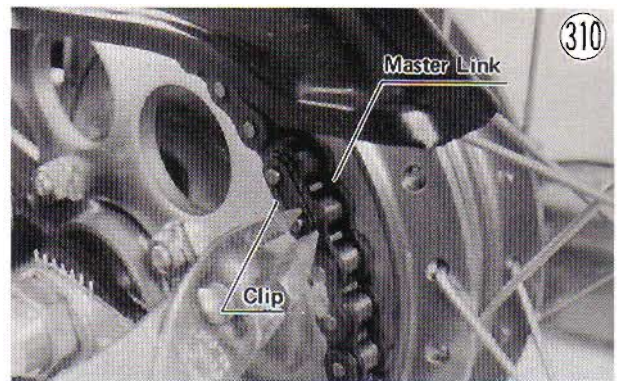

- Remove the drive chain from the sprockets.
- B. If the chain is being replaced with a new chain:
  - Check to see that the transmission is in neutral.
  - Remove the clip from the drive chain master link with pliers, and remove the master link.
  - Fit the new chain on the end of the old chain with the master link.

#### Installation:

- Fit the original chain back on the engine sprocket or pull the new chain onto the engine sprocket by pulling the old one off. Set the ends of the chain on the rear sprocket as shown in Fig. 311.

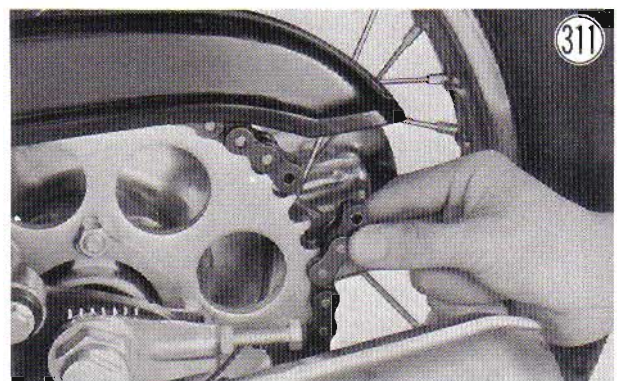

- Install the chain master link with pliers. The direction of the master link clip should be as shown in Fig. 312.



- Replace the engine sprocket cover (if removed) using the shift shaft oil seal guide (special tool) to protect the oil seal in the cover, and tighten its screws.
- Fit the side stand spring (if removed) into place, and then secure the left foot peg with its bolt.
- Replace the shift pedal (if removed) so that its end

## 82 DISASSEMBLY

matches the level of the dynamo cover lower right screw.

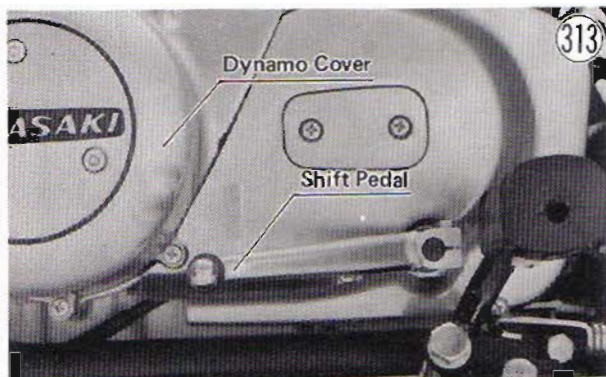

- Adjust the chain if necessary (Pg. 19).

### REAR SPROCKET, WHEEL COUPLING

#### Removal:

- Put the motorcycle up on its center stand.
- Take out the clip from the rear torque link bolt, remove the nut and lock washer, and free the torque link from its bolt.
- Being careful not to bend or otherwise damage it, free the rear brake light switch spring from the tab on the brake pedal.
- Remove the adjusting nut from the end of the brake rod, and then free the rod from the cam lever by depressing the brake pedal. Remove the brake rod spring and joint.
- Take out the cotter pin, remove the axle nut and washer, and pull out the axle.
- Remove the axle sleeve from the right side of the wheel.
- Position the chain on the rear sprocket so that the drive chain master link is at the rear.
- Remove the clip carefully from the drive chain master link using pliers, and then remove the master link.

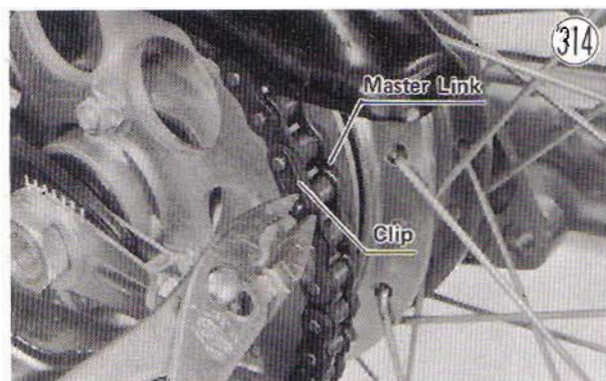

- Turn the rear wheel so that the rear sprocket will be free from the chain.
- Remove the coupling sleeve nut and washer.
- Slide the rear wheel together with the sprocket and coupling free from the motorcycle.
- Straighten back the portions of the rear sprocket washers that are bent over the sprocket nuts.

- Remove the rear sprocket nuts (4), the sprocket double washers (2), and the sprocket bolts to separate the rear sprocket and wheel coupling.

#### Installation:

- Insert the sprocket bolts, and replace the rear sprocket, double washers, and nuts. Tighten the nuts with 3.5 ~ 4.3 kg-m (25 ~ 31 ft-lbs) of torque and bend the washers back over the nuts.
- Check to see that the torque link bolt is in place in the brake panel, and slip the wheel into place inserting the coupling sleeve through the left chain adjuster and left side of the swing arm.
- Position the wheel far enough forward to facilitate chain installation, and replace the coupling sleeve flat washer and nut.
- Replace the axle sleeve.
- Slide the axle through the hub from the left to the right.
- Fit the drive chain back onto the rear sprocket, and set the ends into the position shown in Fig. 315.



- Replace the chain master link using pliers. The direction of the master link clip should be as shown in Fig. 316.



- Loosen the coupling sleeve nut, and adjust the chain with the left and right chain adjusters so that the chain will have a maximum of about 20~25 mm of vertical movement at its greatest point. To keep the chain and wheel aligned, the notch in the left chain adjuster must come to the same swing arm mark that the right chain

adjuster notch comes to.

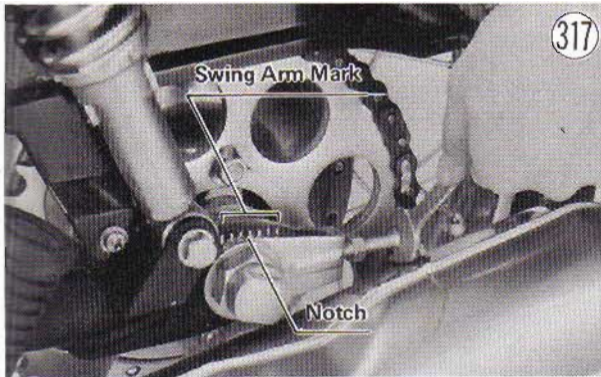

- Tighten the coupling sleeve nut securely.
- Recheck the chain tension, and readjust if necessary.
- Fit the torque link onto its bolt, and replace its lock washer and nut.
- Tighten the torque link nut with 2.7~3.0 kg-m (19.5~22 ft-lbs) of torque, and replace its clip.
- Replace the axle washer and nut, tightening the nut to 13~16 kg-m (94~116 ft-lbs) of torque.
- Install a new axle cotter pin.
- Replace the joint into the end of the cam lever and the spring on the end of the brake rod.
- Fit the rod through the joint, and screw on the adjuster.
- Carefully fit the rear brake light switch spring back into the tab on the brake pedal.
- Adjust the rear brake (Pg. 18 ), and check the rear brake light switch adjustment (Pg. 19 ).

#### Coupling Disassembly:

- Pull out the sleeve, and pull off the collar.
- Pull out the grease seal using a hook.
- Insert a metal rod into the wheel side of the coupling, and remove the bearing by tapping evenly around the bearing inner race.

#### Coupling Assembly Notes:

1. Replace the grease seal with a new one using the wheel bearing driver "B" and the bearing driver holder (special tools).



2. Inspect the bearing, and replace if necessary (Pg. 132). Lubricate it (Pg. 132), and install it using the wheel bearing driver "B" and the bearing driver holder (special tools).

## HANDLEBAR

### Removal:

- Remove the clutch adjusting cover.
- Loosen the lock nut, and back out the clutch adjusting screw to give the clutch cable plenty of play.

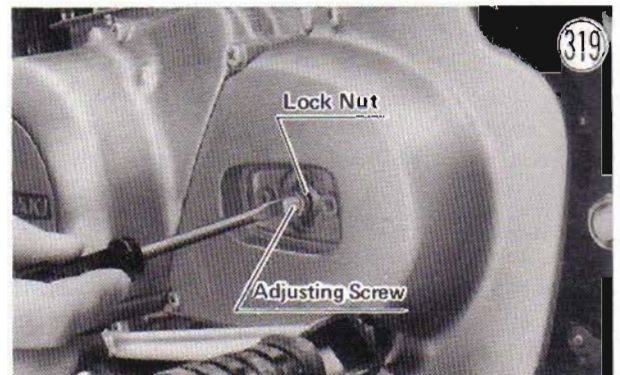

- Take off the rear view mirrors.
- Loosen the lock nut on the clutch lever, and screw in the adjuster.
- Line up the slots in the clutch lever, lock nut, and adjuster, and free the inner cable from the lever.

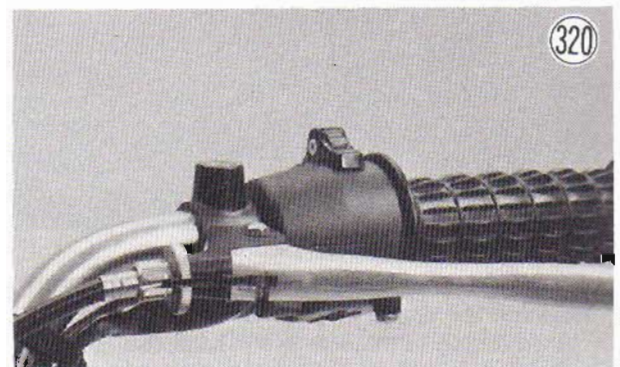

- Remove the strap which holds the light switch wiring harness to the handlebar and the strap which holds the engine stop switch wiring harness to the handlebar.
- Take out the light switch screws (2), and remove the light switch from the handlebar.
- Remove the engine stop switch housing screws (2), and open up the housing.
- Loosen the master cylinder clamp bolts (2).
- Remove the handlebar clamp bolts (4), remove the clamps (2), and slide the handlebar from the master cylinder and the engine stop switch and throttle grip assembly.

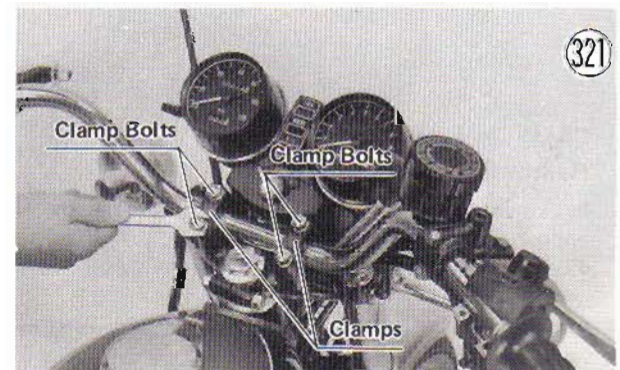

## 84 DISASSEMBLY

- To remove the clutch lever, loosen the clutch lever bolt, cut off the left handlegrip, which is bonded to the handlebar, and slide off the clutch lever.

### Installation:

- If the clutch lever and left handlegrip were removed, slide the clutch lever back on, tighten its bolt with the lever at the proper angle, and bond a new left handlegrip onto the handlebar.
- Slide the right side of the handlebar through the master cylinder holder into the engine stop switch housing and throttle grip assembly; mount it in its clamps so that the angle of the handlebar matches the angle of the front fork as shown in Fig. 322. Torque for the handlebar clamp bolts is 1.1 ~ 1.5 kg-m (95 ~ 130 in-lbs). Each bolt has a lock washer.



- Position the engine stop switch housing in place with its projection in the hole in the handlebar, and tighten its screws.
- With the brake lever mounted at the proper angle, tighten first the upper and then the lower master cylinder clamp bolt to 0.6 ~ 0.9 kg-m (46 ~ 78 in-lbs) of torque.
- Replace the light switch.
- Strap both the light switch wiring harness and the engine stop switch wiring harness back onto the handlebar.
- Replace the rear view mirrors.
- Fit the tip of the clutch cable back into the clutch lever.
- Adjust the clutch (Pg. 11).

## CLUTCH CABLE

### Removal:

- Take out the shift pedal bolt, and remove the shift pedal.
- Remove the left foot peg bolt, left foot peg, and side stand spring.
- Remove the engine sprocket cover screws (4), and pull the cover out of place.

- Remove the cotter pin from the clutch release lever, and free the clutch inner cable tip from the lever and the engine sprocket cover.

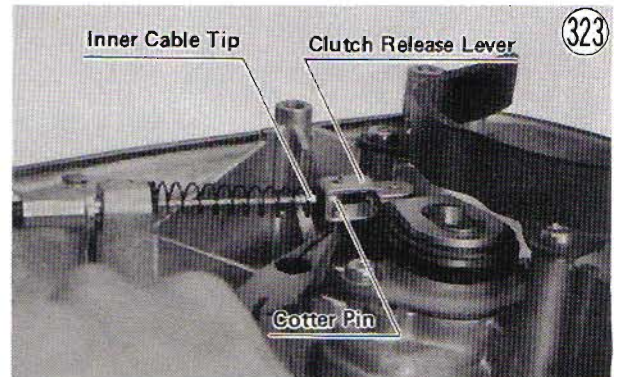

- Unfasten the straps (2) that hold the clutch cable to the down tube, slip out the cable, and refasten the straps.
- Loosen the lock nut on the clutch lever, and screw in the adjuster.
- Line up the slots in the clutch lever, lock nut, and adjuster, and free the inner cable from the lever.

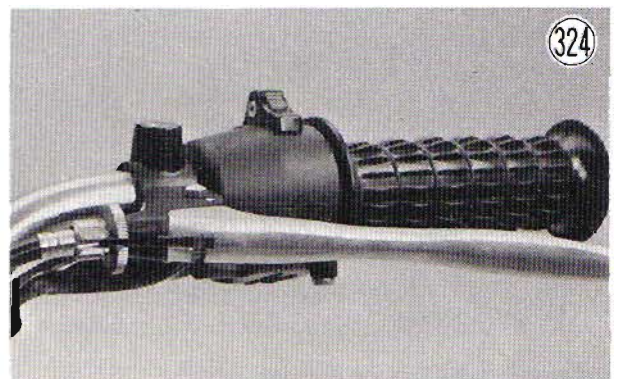

- Pull the cable free from the motorcycle.

### Installation:

- Run the upper end of the cable between the left front shock absorber and the head pipe to the clutch lever.
- Fit the tip of the cable back into the clutch lever.
- Run the lower end of the clutch cable between the left down tube and the lower part of the engine into the engine sprocket cover and spring, and fit the tip of the inner cable into the clutch release lever.
- Using a new cotter pin, secure the cable tip to the release lever.
- Replace the engine sprocket cover using the shift shaft oil seal guide (special tool) to protect the oil seal in the cover, and tighten its screws.
- Fit the side stand spring into place, and then secure the left foot peg with its bolt.

- Replace the shift pedal so that its end matches the level of the dynamo cover lower right screw.

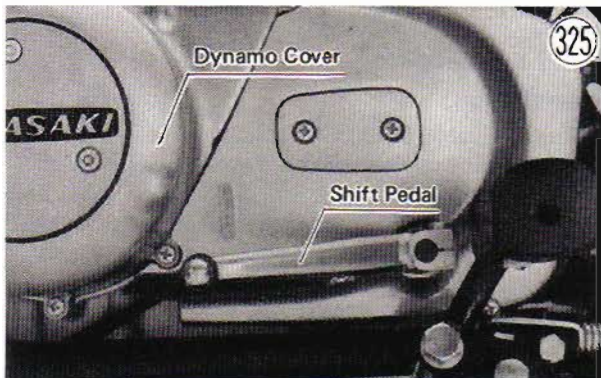

- Secure the cable to the left down tube with the straps (2).
- Adjust the clutch (Pg. 11).

## THROTTLE CABLES

### Removal:

- Unlock the seat, and lift it up.
- Turn the fuel tap lever to the STOP position, slide back the hose clamps, and pull the fuel hoses (2) off the tap.
- Unhook the retaining band, and pull the tank off towards the rear.
- Screw in fully the lock nuts and adjusting nuts at the upper end of the throttle cables so as to give the throttle grip plenty of play.
- Screw one of the cable adjusters out of its bracket, slip the tip of its inner cable out of the pulley, and then do the same with the other throttle cable.



- Slide the cables out of the straps which secures them to the top tube.
- Remove the engine stop switch housing screws (2), and open up the housing.
- Unscrew the adjusting nut for the decelerator throttle cable (the cable next to the starter button), slide it out of the way, and unscrew the decelerator throttle cable guide from the engine stop switch housing.

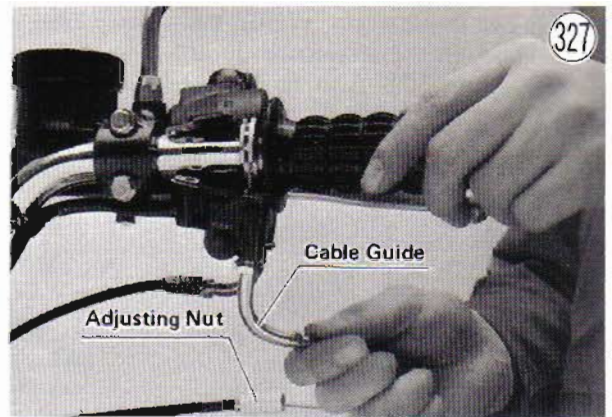

- Slip the decelerator throttle cable tip from its catch in the throttle grip, and pull the cable out of the engine stop switch housing and free from the motorcycle.

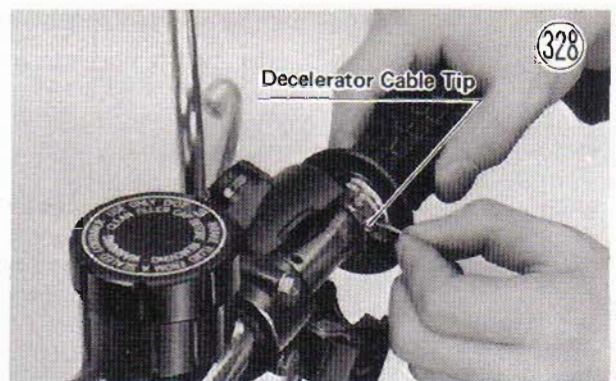

- Unscrew the accelerator throttle cable guide from the engine stop switch housing, slip the cable tip out of its catch in the throttle grip, and pull the cable from the engine stop switch and free from the motorcycle.

### Installation:

- Screw the accelerator throttle cable guide (shorter than the decelerator throttle cable guide) into the side of the engine stop switch opposite from the starter button. Screw it in most all the way, and then tighten lightly the guide nut.

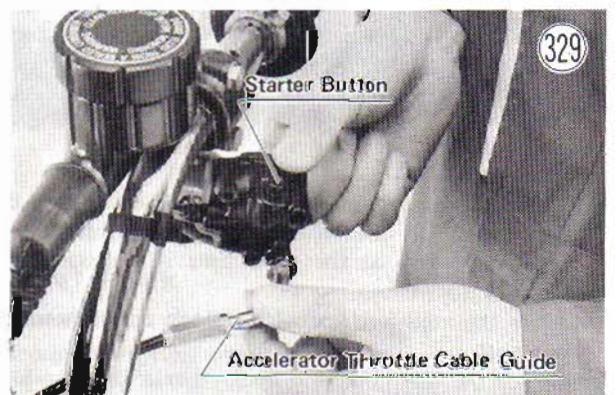

- Screw in the decelerator cable guide most all the way, and then tighten lightly the guide nut.

## 86 DISASSEMBLY

- Turn the throttle grip so that the cable catches are facing up, fit the accelerator throttle cable tip to the right and the other cable tip to the left.



- Put together the engine stop switch housing, and tighten its screws. The upper half of the housing has a small projection which fits into a hole in the handlebar.
- Screw the adjusting nut back onto the decelerator throttle cable guide.
- Run both cables between the right front shock absorber and the head pipe, through its straps on the top tube with the accelerator throttle cable above the other cable to the carburetors. The cables should be naturally routed, neither one twisted about the other.
- Turn each guide in the direction of its cable, and tighten its guide nut to secure its guide in the proper position.
- Fit the tip of the accelerator throttle cable into the rear catch in the pulley, and screw its adjuster down into the bracket all the way.



- Fit the tip of the decelerator throttle cable into the other catch, lift the adjuster into its bracket turning the throttle grip at the same time if necessary, and screw its adjuster in.
- Center the adjusters in their brackets, and tighten the lock nuts.
- Replace the fuel tank, and hook its retaining band.
- Fit the fuel hoses back onto the fuel tap, and slide the clamps back into place.
- Push the seat into place.
- Adjust the throttle cables (Pg. 9).

## SPEEDOMETER CABLE

### Removal:

- Disconnect the upper and lower ends of the speedometer cable with pliers.
- Pull the cable free.

### Installation:

- Run the cable through its guide, and secure the upper end of the cable to the speedometer with pliers.
- Insert the speedometer inner cable into the speedometer gear housing while turning the wheel so that the slot in the end of the cable will seat in the tongue of the speedometer pinion. Tighten the cable nut with pliers.

## TACHOMETER CABLE

### Removal:

- Disconnect the upper and lower ends of the tachometer cable with pliers.
- Free the cable from the motorcycle.

### Installation:

- Run the tachometer cable through its guide, fit the inner cable into the tachometer, and tighten the cable nut with pliers.
- Fit the bottom end of the cable into its place in the cylinder head cover. Turn it if necessary so that it fits all the way back into place, and tighten its nut with pliers.

## SPEEDOMETER

### Removal:

- Disconnect the upper end of the speedometer cable with pliers.
- Remove the cap nuts (2) from the bottom of the speedometer holder. Each cap has a lock washer and flat washer.
- Pull up on the speedometer, and pull out the illuminator lights (2) from its base to complete speedometer removal.

### Installation Note:

- Be sure the cable runs through its guide at the 3-way joint.

## TACHOMETER

### Removal:

- Disconnect the upper end of the tachometer cable with pliers.
- Remove the cap nuts (2) from the bottom of the tachometer holder. Each cap nut has a lock washer and flat washer.
- Pull up on the tachometer, and pull out the illuminator lights (2) and indicator lights (2).

### Installation Note:

- The proper connections in the base of the tachometer are as follows: black/yellow and blue to tachometer illuminator light sockets (2), black/red and black/yellow to high beam indicator light socket, and brown and green/white to brake light failure indicator light socket.

**HEADLIGHT UNIT**

Headlight Unit

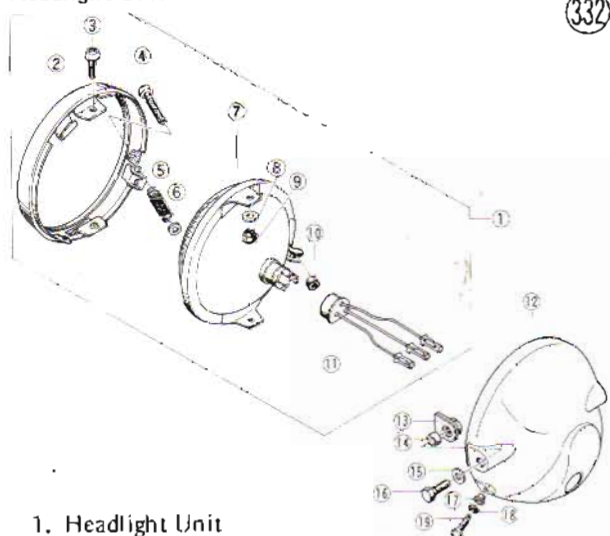

- |                     |                            |
|---------------------|----------------------------|
| 1. Headlight Unit   | 11. Socket                 |
| 2. Rim              | 12. Headlight Housing      |
| 3. Mounting Screws  | 13. Nuts                   |
| 4. Adjust Screw     | 14. Collar                 |
| 5. Spring           | 15. Washer                 |
| 6. Washer           | 16. Housing Mounting Bolts |
| 7. Sealed Beam Unit | 17. Collar                 |
| 8. Washers          | 18. Lock Washer            |
| 9. Nuts             | 19. Retaining Screws       |
| 10. Nut             |                            |

**Removal:**

- Take out the retaining screws (19) (2), pull the bottom of the headlight unit (1) out of its housing (12), and then push down on the top of the headlight rim (2) to free the unit from the housing.
- Disconnect the headlight socket (11) from the rear of the unit.
- Remove the mounting screws (3), nuts (9), washers (8) (2 ea), and the beam horizontal adjust screw (4). A nut (10), washer (6), and spring (5) come off with the adjust screw.

**Installation Notes:**

1. The washer on the adjust screw goes between the spring and the bracket.
2. The top of the sealed beam unit is marked TOP.
3. Carry out the horizontal beam adjustment after installation (Pg. 20).

**INDICATOR LIGHTS (turn, neutral, & oil)****Removal:**

- Remove the nut from the ignition switch, and take off the ignition switch upper cover.
- Remove the indicator lights (3).

**Installation Note:**

- Use 12V 3.4W bulbs for indicator light replacement.

**IGNITION SWITCH****Removal:**

- Take out the retaining screws (2), pull the bottom of the headlight unit out of its housing, and then push down on the top of the headlight rim to free the unit from the housing.
- Disconnect the headlight socket from the rear of the unit.
- Remove the headlight housing mounting bolts (2). Each bolt has a nut and washer.
- Remove the headlight housing.
- Remove the nut from the ignition switch, and take off the ignition switch upper cover.
- Disconnect the ignition switch wiring harness socket from the plug it connects to in the headlight housing, and push the socket out of the housing.
- Remove the ignition switch lower cover screws (2), and remove the ignition switch lower cover, ignition switch fitting, and ignition switch.

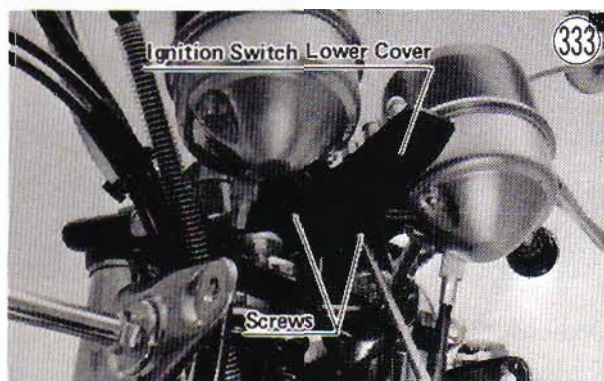
**Installation:**

- Fit the ignition switch, switch fitting, and lower cover in place, and screw in both lower cover screws. Each screw has a lock washer.
- Reconnect the ignition switch wiring harness socket to its plug in the headlight housing.
- Fit the ignition switch upper cover in place, and tighten its nut.
- Mount the headlight housing in place tightening its mounting bolts. The sequence is mounting bolt, flat washer, fork cover, housing insert, and nut.
- Connect the headlight plug to the headlight, fit the headlight into the housing, and tighten its retaining screws. Each screw has a lock washer.
- Adjust the headlight vertically (Pg. 21).

**FRONT FORK****Removal (left shock absorber):**

- Remove the front wheel (Pg. 71).
- Remove the bolts (3) that hold the front fender to the left shock absorber.
- Remove the caliper mounting bolts (2), and rest the caliper on some kind of stand so that the pipe does not get bent.

## 88 DISASSEMBLY

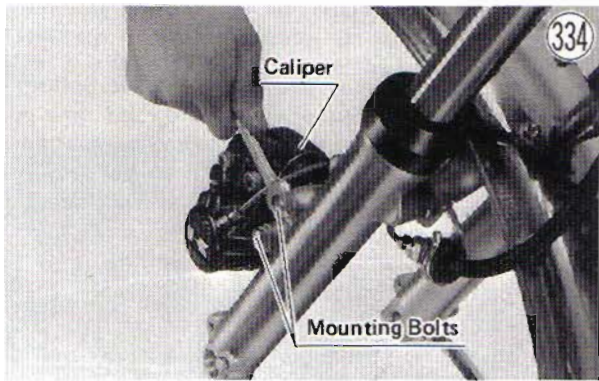

- If the shock absorber is to be disassembled after removal, loosen the shock absorber top bolt.

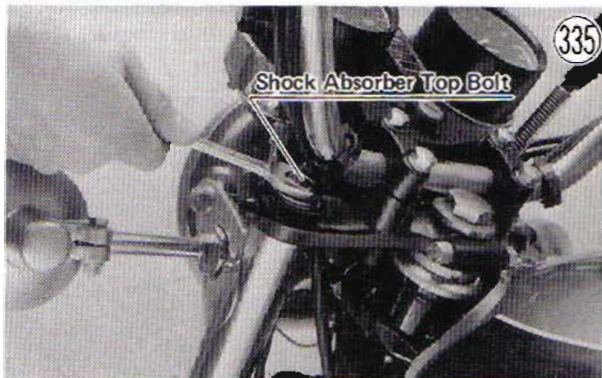

- Loosen the upper and lower clamp bolts.



- With a twisting motion, work the shock absorber down and out.

### Installation (left shock absorber):

- Slide the shock absorber up through the lower and upper clamps until the upper surface of the tube is even with the upper surface of the stem head. Tighten the upper clamp bolts with 1.6 ~ 1.8 kg-m (12 ~ 13 ft-lbs) of torque and the lower clamp bolts with 2.0 ~ 3.0 kg-m (14.5 ~ 22 ft-lbs).
- If the top bolt was loosened during removal, tighten it with 2.5 ~ 3.0 kg-m (18 ~ 22 ft-lbs) of torque.
- Mount the caliper to the shock absorber tightening the bolts with 2.5 ~ 3.3 kg-m (19 ~ 23 ft-lbs) of torque. Each mounting bolt has a flat washer and lock washer.
- Install the fender bolts. There is a lock washer for each bolt.

- Mount the front wheel (Pg. 71).

### Removal (right shock absorber):

- Remove the front wheel (Pg. 71).
- Remove the bolts (3) that hold the front fender to the right shock absorber.
- If the shock absorber is to be disassembled after removal, loosen the shock absorber top bolt.
- Loosen the upper and lower clamp bolts.
- With a twisting motion, work the shock absorber down and out.

### Installation (right shock absorber):

- Slide the shock absorber up through the lower and upper clamps until the upper surface of the tube is even with the upper surface of the stem head. Tighten the upper clamp bolts with 1.6 ~ 1.8 kg-m (12 ~ 13 ft-lbs) of torque and the lower clamp bolts with 2.0 ~ 3.0 kg-m (14.5 ~ 22 ft-lbs).
- If the top bolt was loosened during removal, tighten it with 2.5 ~ 3.0 kg-m (18 ~ 22 ft-lbs) of torque.
- Install the fender bolts. There is a lock washer for each bolt.
- Mount the front wheel (Pg. 71).

### Disassembly:

- Remove the top bolt ①, and pull out the spring ②.
- Pour the oil into a suitable container, pumping as necessary to empty out all the oil.
- Slide the dust seal ③ off the inner tube ④.
- Keeping the cylinder & piston unit ⑤ from turning by use of the front fork cylinder holder and holder adapter (special tools), unscrew the Allen bolt ⑥ from the bottom of the outer tube ⑦, and then separate the inner tube from the outer tube by pulling it out.

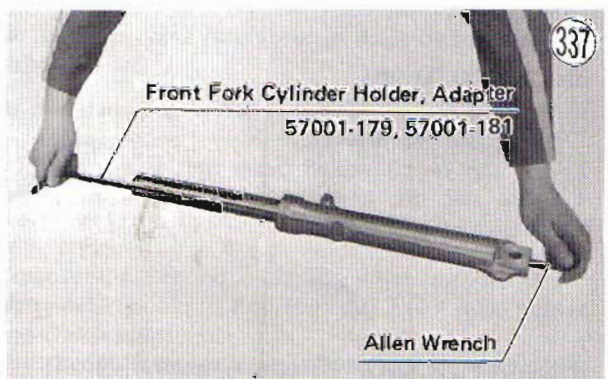

- Slide or push the cylinder & piston unit and its spring ⑧ out the top of the inner tube.
- Remove the clip ⑨ from the outer tube, and then pull out the oil seal ⑩.
- Remove the cylinder base ⑪ out the top of the outer tube.

## Front Fork

338

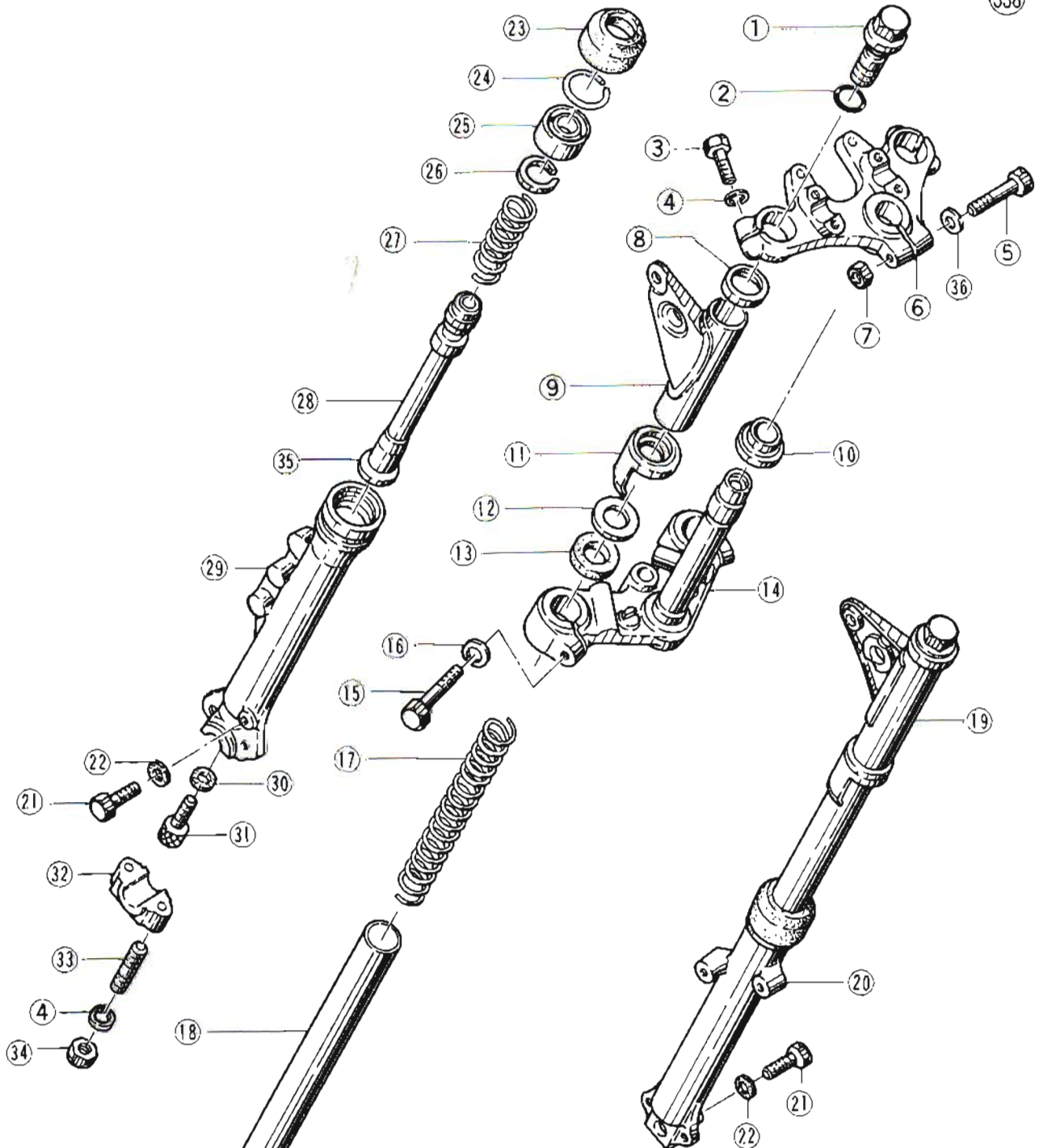

1. Top Bolt
2. O Ring
3. Upper Clamp Bolt
4. Lock Washer
5. Stem Head Clamp Bolt
6. Stem Head
7. Nut
8. Ring Cap
9. Left Fork Cover
10. Inner Race
11. Stem Base Cover
12. Damper Ring

13. Damper
14. Steering Stem
15. Lower Clamp Bolt
16. Lock Washer
17. Spring
18. Inner Tube
19. Right Fork Cover
20. Right Outer Tube
21. Bolt
22. Gasket
23. Dust Seal
24. Clip

25. Oil Seal
26. Piston Ring
27. Spring
28. Cylinder
29. Left Outer Tube
30. Gasket
31. Allen Bolt
32. Axle Clamp
33. Stud Bolt
34. Nut
35. Cylinder Base
36. Lock Washer

## 90 DISASSEMBLY

### Assembly:

- Place the cylinder base into the outer tube.
- Replacing the oil seal for a new one, apply oil to the outside, and fit it in with the front fork oil seal driver (special tool).



- Replace the clip.
- Replace the cylinder & piston unit together with its spring into the inner tube, pushing it all the way down so that the cylinder projects out the bottom.
- Fit the bottom of the cylinder into the cylinder base, and then push the inner tube fully into the outer tube.
- Apply a non-permanent locking agent to the Allen bolt, and tighten it in place.
- Slide the dust seal into place.
- Refill with 160 cc of fresh SAE 5W20 oil.
- Insert the spring with the concentrated portion up.
- Replace the top bolt.

### STEERING STEM

#### Removal:

- Uncap the bleed valve on the caliper, connect one end of a clear plastic hose to the valve, and run the other end of the hose into a container.

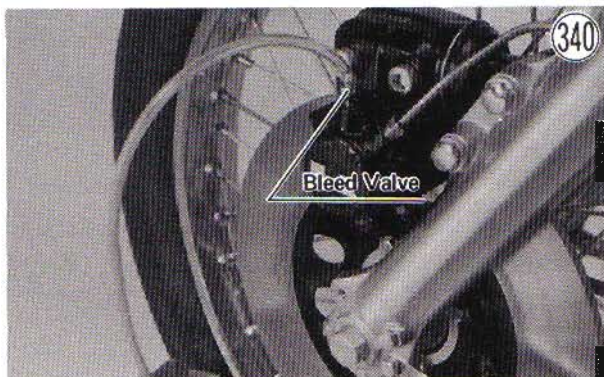

- Open the bleed valve, and pump the brake lever until all the fluid is drained.
- Remove the plastic hose, close the bleed valve, and replace the cap.
- Remove the front wheel (Pg. 71).
- Remove the clamp bolts (2) which secure the master cylinder to the handlebar, remove the banjo bolt that

connects the upper brake hose to the 3-way joint, and then remove the master cylinder together with the upper brake hose. The banjo bolt has a flat washer on each side of the upper brake hose fitting. Wipe up immediately any brake fluid that spills.

- Remove the caliper mounting bolts (2) and the lower brake hose banjo bolt, and remove the caliper together with the lower brake hose by pulling the lower brake hose fitting through the fender rubber mount. The banjo bolt has a flat washer on each side of the lower brake hose fitting. Wipe up immediately any brake fluid that spills.
- Remove the fender bolts (6), and take off the fender.
- Loosen the upper and lower clamp bolts on both sides, and remove each shock absorber by working it down and out.

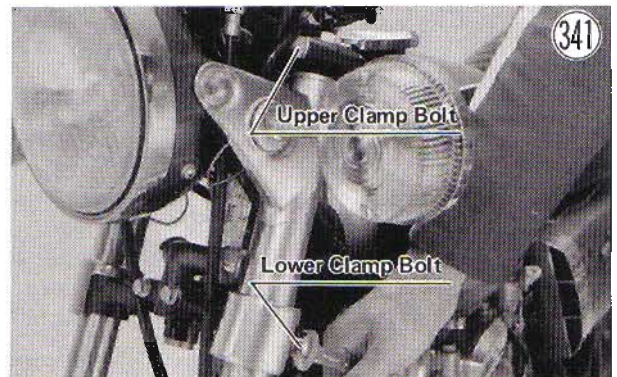

- Remove the tachometer cable guide bolt, and disconnect the tachometer cable at the tachometer.
- Disconnect the front brake light switch leads from the switch.
- Remove the 3-way joint.
- Take out the retaining screws (2), pull the bottom of the headlight unit out of its housing, and then push down on the headlight rim to free the unit from the housing.
- Disconnect the headlight socket from the rear of the unit.
- Disconnect the turn signal leads (gray and black/yellow) and the main wiring harness plugs.
- Remove the headlight housing mounting bolts (2). Each bolt has a flat washer and nut.
- Remove the headlight housing.
- Holding the instrument unit so that it doesn't fall, remove the nuts (2) that secure the instrument unit to the stem head, and then remove the instrument unit.

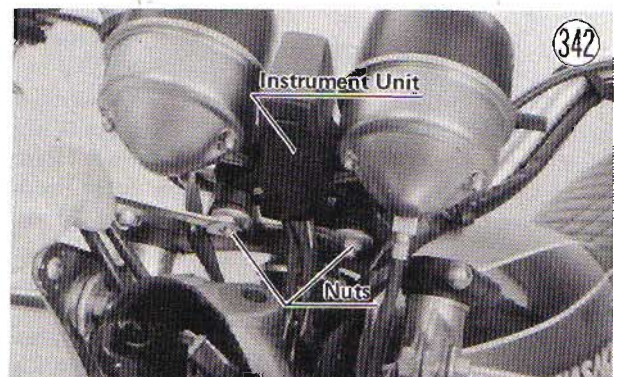

- Loosen the stem head clamp bolt, stem head bolt, and stem head flat washers (2).
- Tap lightly on the bottom of the stem head with a plastic hammer, and remove the fork covers together with the turn signals. Each fork cover has the ring cap at the top and the damper, damper ring, and stem base cover at the bottom.
- Continue tapping up the stem head until it is free of the steering stem. Let the stem head & handlebar assembly all hang down out of the way.

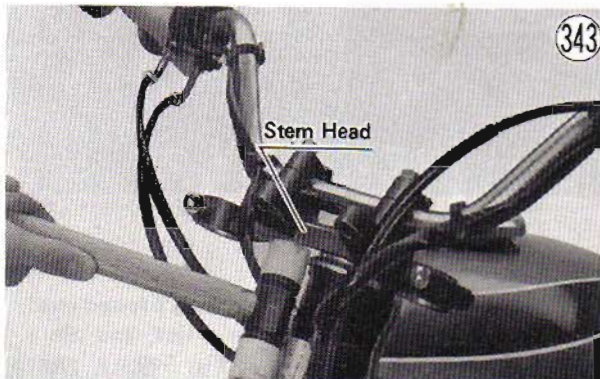

- Pushing up on the stem base, remove the steering stem lock nut with the stem nut wrench (special tool); then remove the steering stem and stem base (single unit). As the stem is removed, some of the steel balls will drop out of the lower outer race. Remove the rest.



- Remove the steering stem cap and upper inner race, and remove the upper steel balls (19).

#### Installation:

- Apply grease to the upper and lower outer races in the head pipe so that the steel balls will stick in place during stem insertion, and then replace the upper steel balls (19) and the lower steel balls (19).
- Insert the steering stem into the head pipe, replace the upper inner race and steering stem cap, and then tighten the steering stem lock nut, with 2.7~3.0 kg-m (19.5~22 ft-lbs) of torque.

**Note:** The steering stem lock nut torque is only provisional. The tightness changes with steering stem adjustment.

- Tap the stem head part of the way into place on the steering stem.

- Route the main wiring harness directly in front of the steering stem, and route the light switch wiring harness and clutch cable in back next to the head pipe.

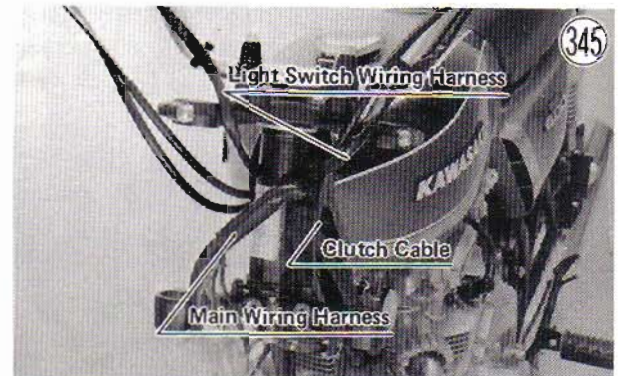

- Slide the left shock absorber (the one that holds the caliper) through the left stem base, fork cover, and stem head so that the upper surface of the tube is even with the upper surface of the stem head; tighten the upper clamp bolt with 1.6~1.8 kg-m (12~13 ft-lbs) of torque. The sequence is stem base, damper, damper ring, base cover, fork cover, ring cap, and stem head.
- Replace the right shock absorber in the same manner as the left. The throttle cables run between the shock absorber and head pipe. The engine stop switch wiring harness runs in front of both the shock absorber and head pipe.

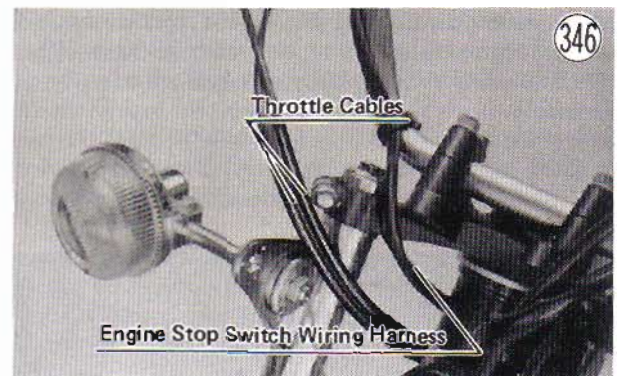

- Tap the stem head lightly with a plastic hammer the rest of the way, and replace the stem head flat washers (2) (thick washer on top) and bolt. Tighten with 5.5 kg-m (40 ft-lbs) of torque.
- Tighten the stem head clamp bolt with 1.6~1.8 kg-m (12~13 ft-lbs) of torque.
- Tighten the stem base clamp bolts with 2.0~3.0 kg-m (19.5~22 ft-lbs) of torque.
- Secure the instrument unit to the stem head, and tighten the nuts with washers.
- Replace the 3-way joint. Be sure to include the cable guide with each bolt.

## 92 DISASSEMBLY

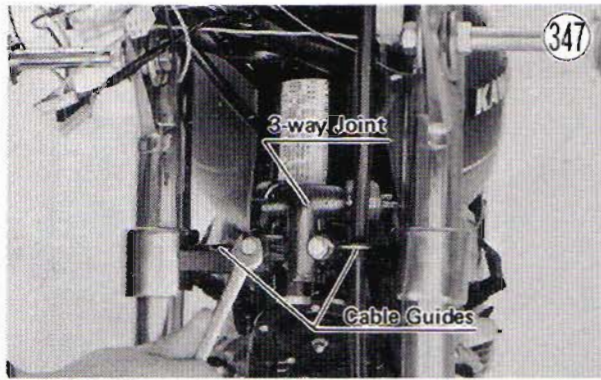

- Connect the front brake light switch leads onto the switch. The leads may connect either way.
- Run the plugs, sockets, and wiring into the headlight housing, and connect the plugs and sockets.
- Mount the headlight housing in place tightening its mounting bolts. The sequence is mounting bolt, flat washer, fork cover, housing insert, and nut.
- Connect the turn signal leads. The left turn signal lead goes to the green lead, and the right is plugged into the gray lead. Both turn signal black/yellow leads go to the same black/yellow plug.
- Connect the headlight plug to the headlight, fit the headlight into the housing, and tighten its retaining screws. Each screw has a lock washer.
- Run the tachometer cable through its guide, fit the inner cable into the tachometer, and tighten the cable nut with pliers.
- Install the front fender tightening its bolts (6). Each bolt has a lock washer.
- Run the lower brake hose fitting through the fender rubber mount, and mount the caliper to the shock absorber tightening the bolts with 2.5~3.3 kg-m (19 ~ 23 ft-lbs) of torque. Each bolt has a flat washer and lock washer.
- Connect the lower brake hose fitting to the 3-way joint tightening its banjo bolt with 2.5~3.3 kg-m (18~24 ft-lbs) of torque. There is a flat washer for each side of the fitting.
- Install the master cylinder to the handlebar with the small projection on the clamp facing the throttle grip. Tighten first the upper clamp bolt and then the lower bolt, both with 0.6~0.9 kg-m (46~78 in-lbs) of torque. Each clamp bolt has a flat washer.
- Run the upper brake hose fitting to the 3-way joint, and tighten its banjo bolt with 2.5~3.3 kg-m (18~24 ft-lbs) of torque. There is a flat washer for each side of the fitting.
- Install the front wheel (Pg. 71 ).
- Adjust the steering (Pg. 16 ).
- Adjust the headlight vertically (Pg. 21 ).
- Refill the brake lines (Pg. 137).

## STEERING STEM BEARING

### Removal:

- Remove the steering stem (Pg. 92 ).

- To remove the outer races pressed into the head pipe, insert a bar into the head pipe, and hammer evenly around the circumference of each race to drive it out.

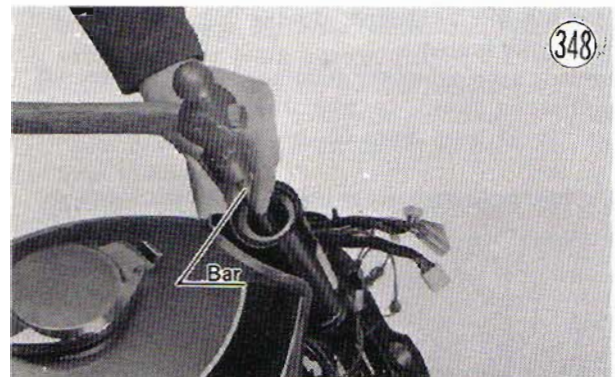

- To remove the lower inner race, which is pressed onto the steering stem, grip the stem in a vice, and use a metal rod and hammer as shown in Fig. 349.

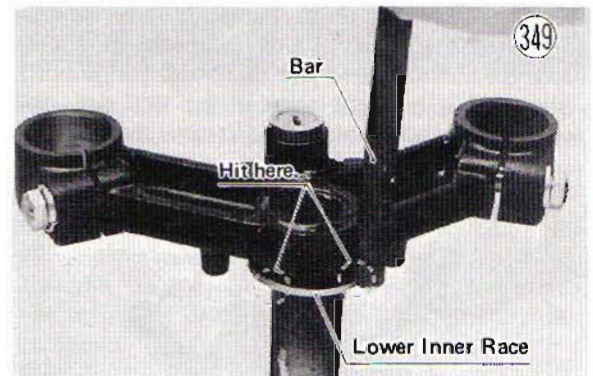

### Installation:

- Apply oil to the outer races, and drive them into the head pipe using the stem cup driver and the bearing driver holder (special tools).



- Apply oil to the lower inner race, and drive it onto the steering stem using the stem bearing driver and adapter (special tools).



- Install the steering stem (Pg. 92 ).

## SWING ARM

### Removal:

- Put the motorcycle up on its center stand.
- Take out the clip from the rear torque link bolt, remove the nut and lock washer, and free the torque link from its bolt.
- Being careful not to bend or otherwise damage it, free the rear brake light switch spring from the tab on the brake pedal.
- Remove the adjusting nut from the end of the brake rod, and then free the rod from the cam lever by depressing the brake pedal. Remove the brake rod spring and joint.
- Take out the cotter pin, remove the axle nut and washer, and pull out the axle.
- Remove the axle sleeve from the right side of the wheel.
- Position the chain on the rear sprocket so that the drive chain master link is at the rear.
- Remove the clip carefully from the drive chain master link using pliers, and then remove the master link.

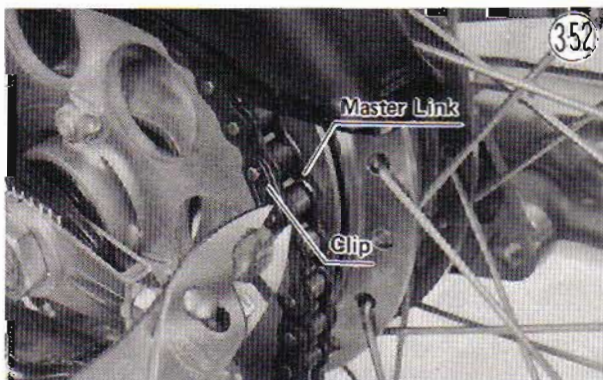

- Turn the rear wheel so that the rear sprocket will be free from the chain.
- Remove the coupling sleeve nut and washer.

- Slide the rear wheel together with the sprocket and coupling free from the motorcycle.
- Remove both chain adjusters.
- Remove the rear shock absorber bolts and lock washers (2 ea).
- Remove the pivot shaft nut, and pull out the pivot shaft.

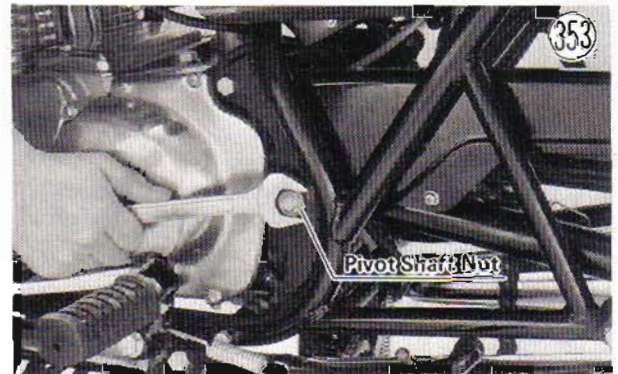

- Pull the swing arm free from the motorcycle. A cap on each side of the pivot will drop off.
- Take out the screws (2) to remove the chain guard.
- Remove the clip, nut, lock washer, and bolt to remove the torque link.

### Installation:

- Insert the end of the torque link into its place in the swing arm, and replace its bolt, lock washer, nut and clip. The torque for the nut is 2.7 ~ 3.0 kg-m (19.5 ~ 22 ft-lbs).
- Replace the chain guard. Each screw has a lock washer.
- Replace the caps, one on each end of the pivot, position the pivot of the swing arm into its place in the frame, and slide in the pivot shaft from right to left. A screwdriver inserted into the left side of the pivot will keep the left cap in place and can be used to alter the position of the distance collar, if necessary, so that the pivot shaft will run through the pivot easily.



- Replace the pivot shaft and nut; tighten the nut with 10 ~ 13 kg-m (72 ~ 94 ft-lbs) of torque.
- Replace the rear shock absorber bolts and lock washers, tightening each bolt with 2.7 ~ 3.3 kg-m (19.5 ~ 24 ft-lbs) of torque.

## 94 DISASSEMBLY

- Replace both chain adjusters. The right side of the right chain adjuster is thicker than the other sides.
- Check to see that the torque link bolt is in place in the brake panel, and slip the wheel into place inserting the coupling sleeve through the left chain adjuster and left side of the swing arm.

The rest of the steps are the same as those in the rear sprocket and wheel coupling installation (Pg. 82 ),



### Disassembly:

- Using a suitable tool pull out the sleeve ④ from each side of the pivot, and then slide out the distance collar ⑤.

- Use a metal rod and hammer to tap out the bush ⑥ from each side of the pivot.

### Swing Arm

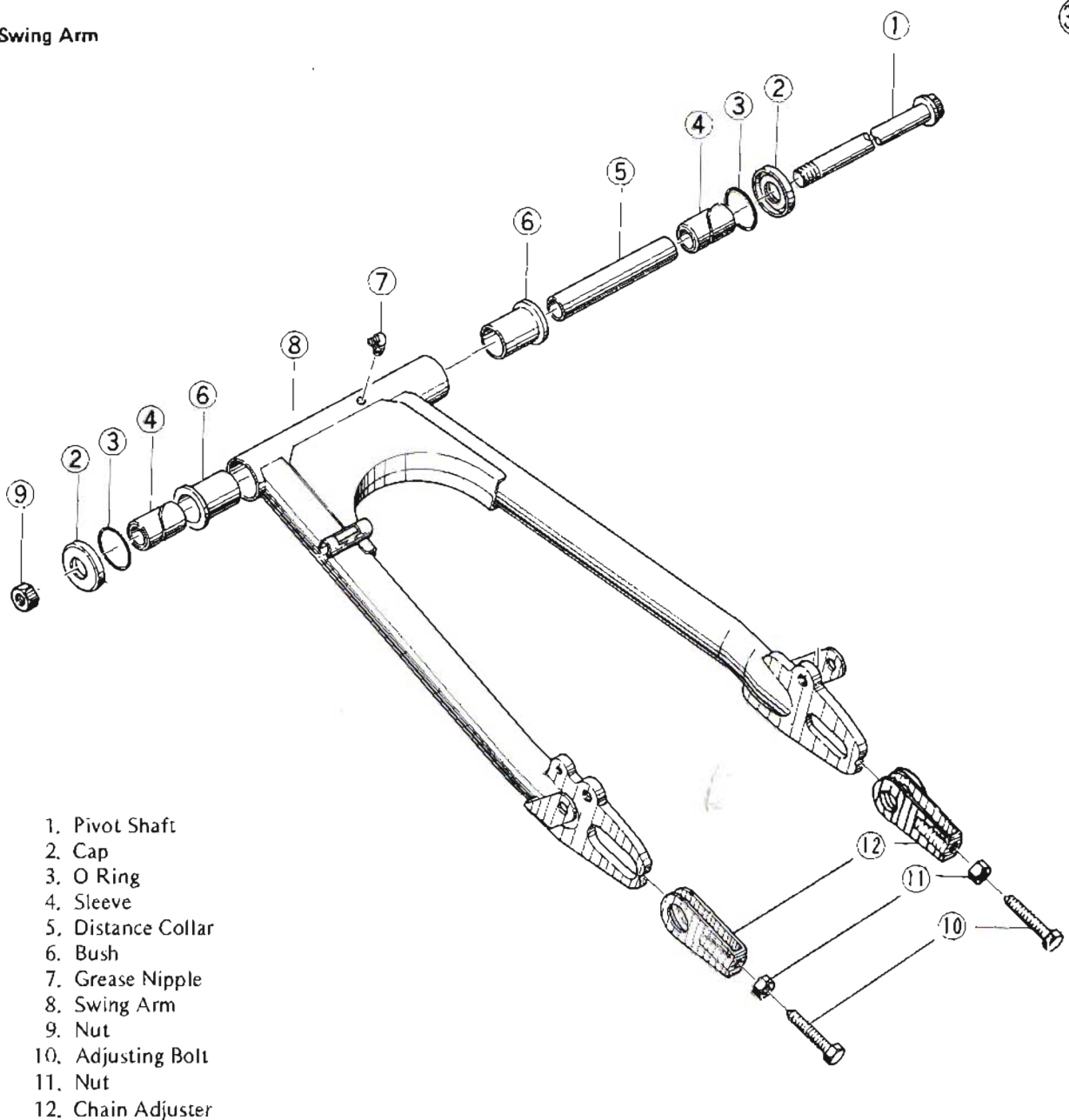

1. Pivot Shaft
2. Cap
3. O Ring
4. Sleeve
5. Distance Collar
6. Bush
7. Grease Nipple
8. Swing Arm
9. Nut
10. Adjusting Bolt
11. Nut
12. Chain Adjuster

**Assembly Notes:**

1. Replace the bushes for new ones if either one has worn past the service limit (Pg. 146) or has been removed. Apply oil to the bushes before installing them with a press.
2. Wipe the old grease off the sleeves, and apply fresh grease, especially in each sleeve groove.

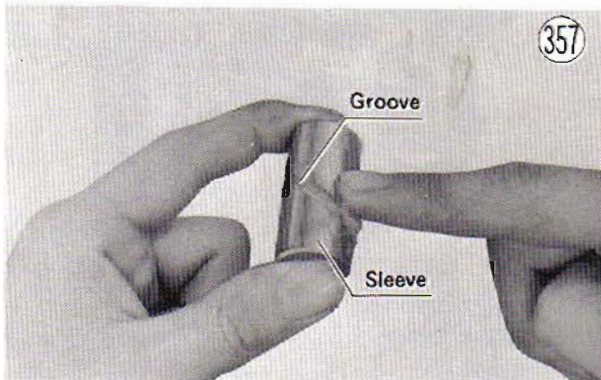
**Installation (both sides):**

- Fit each shock absorber on its stud.
- Lifting up on the rear wheel, insert each shock absorber bolt with its lock washer, and tighten with 2.7 ~ 3.3 kg-m (19.5 ~ 24 ft-lbs) of torque.
- Replace the large flat washer on each stud.
- Fit the chrome bar in place, and tighten its mounting bolts (2). Each bolt has a lock washer and flat washer.
- Replace the flat washer, lock washer, and then cap nut on each side. Tighten the cap nuts with 2.7 ~ 3.3 kg-m (19.5 ~ 24 ft-lbs) of torque.

**REAR SHOCK ABSORBERS****Removal (one side only):**

- Remove the chrome bar mounting bolts (2), loosen the shock absorber cap nuts (2), and take off the chrome bar.
- Lifting up on the rear wheel as necessary to avoid damaging the shock absorber bolt threads, remove the shock absorber bolt.
- Remove the cap nut, lock washer, and flat washers, and pull off the shock absorber.

**Installation (one side only):**

- Fit the shock absorber on its stud.
- Lifting up on the rear wheel, insert the shock absorber bolt with its lock nut, and tighten with 2.7 ~ 3.3 kg-m (19.5 ~ 24 ft-lbs) of torque.
- Replace the large flat washer, small flat washer, and cap nut, and then fit the chrome bar into place between the flat washers on each side.
- Replace and tighten the chrome bar mounting bolts (2). Each bolt has a lock nut washer and flat washer.
- Tighten each cap nut with 2.7 ~ 3.3 kg-m (19.5 ~ 24 ft-lbs) of torque.

**Removal (both sides):**

- Remove the chrome bar mounting bolts (2).
- Remove the rear shock absorber cap nuts (2), and take off the chrome bar. Also remove the lock washers (2) and flat washers (4).
- Lifting up on the rear wheel as necessary to avoid damaging the bolt threads, remove the rear shock absorber bolts (2).
- Pull each shock absorber off its stud.

# Maintenance

## AIR CLEANER

A properly cared for air cleaner ensures that only clean, filtered air is supplied through the carburetor into the engine. If the air is supplied directly without filtering, not only will dirt and dust from the air plug up carburetor passages causing the engine to run poorly, but also the dust that enters the engine will act like grinding compound wearing down the cylinder, piston, and rings. If the air cleaner element is damaged or too coarse, the result will be the same as though no element were used.

An air cleaner element clogged with dirt chokes the air supply to the engine, resulting in an overly rich fuel/air mixture and inefficient combustion. This in turn causes overheating from carbon build-up, reducing engine power.

### *Cleaning and replacement*

The air cleaner element must be cleaned at least every 3,000 km.

Remove the air cleaner element (Pg. 26 ), clean it by swishing it around in a bath of a high flash point solvent of some kind, and then dry it from the inside using compressed air. Since this is a dry-type element, do not use kerosene or any fluid which would leave the element oily.

**NOTE:** Because of the danger of highly flammable liquids, do not use gasoline or low flash point solvents to clean the element.

## CARBURETORS

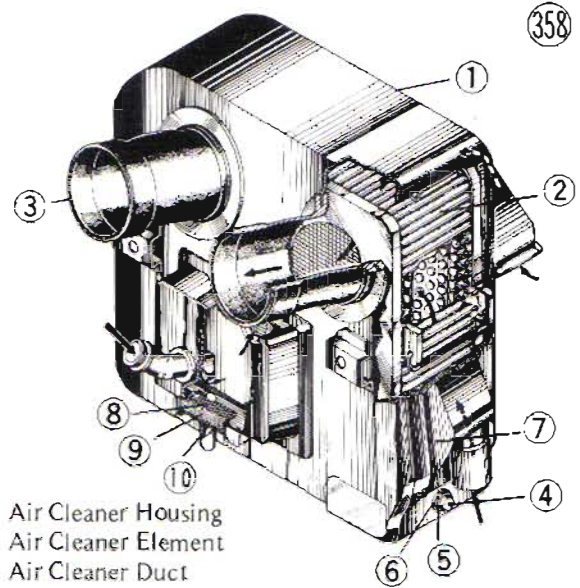

1. Air Cleaner Housing
2. Air Cleaner Element
3. Air Cleaner Duct
4. Screw
5. Lock Washer
6. Washer
7. Side Cover

8. Screen
9. Foam Rubber
10. Screen

Since repeated cleaning coarsens the element, replace it for a new one every 10,000 km or after it has been cleaned 5 times, whichever is sooner. Also, if there is a break in the element material or any other damage to the element, replace the element for a new one.

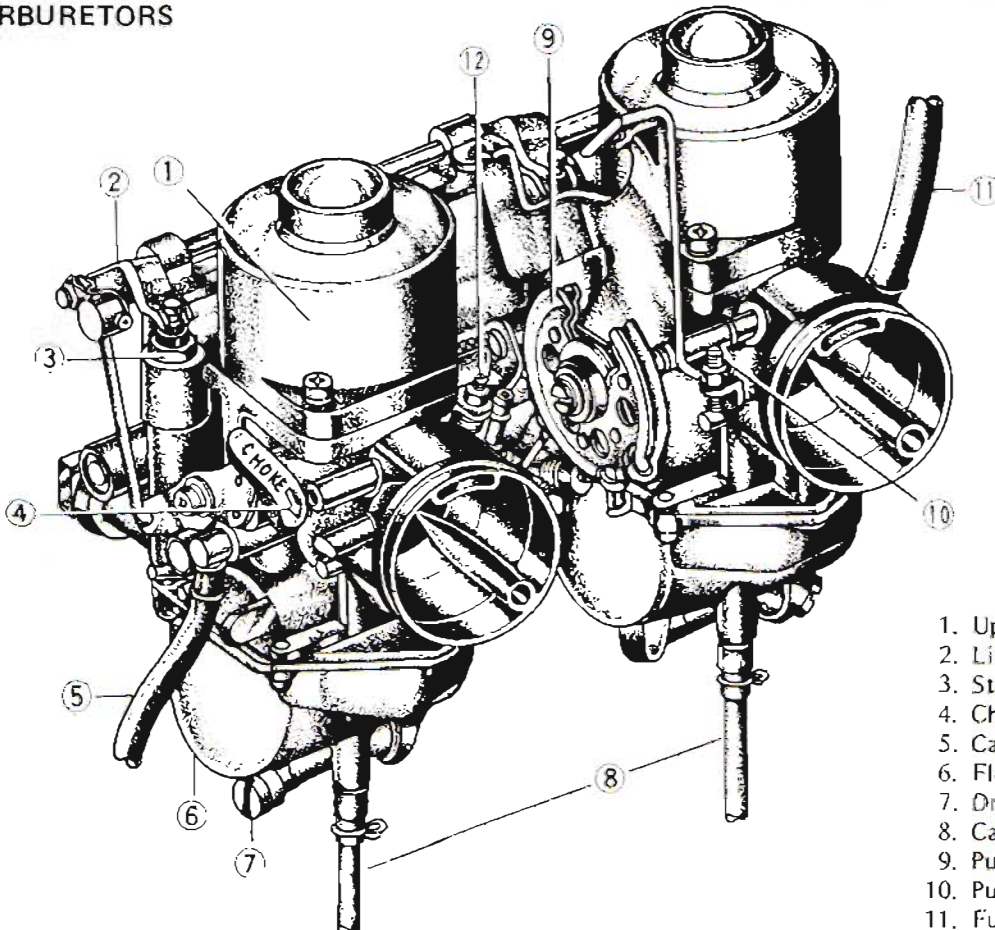

1. Upper Chamber
2. Linkage Mechanism
3. Starter Plunger Unit
4. Choke Lever
5. Carburetor Tube
6. Float Chamber
7. Drain Plug
8. Carburetor Tube
9. Pulley
10. Pulley Stop Screw
11. Fuel Hose
12. Balance Adjusting Screw

The carburetors perform the function of mixing the fuel and air in the proportions necessary for good engine performance at varying speeds and loads. In order for them to function satisfactorily, they must be kept well adjusted and maintained. The throttle cable adjustment (Pg. 9) and the pilot screw, idling, and synchronizing adjustments (Pg. 10 ) are covered in the Adjustment Section. The discussion here concerns the fundamentals of carburetor operation, special adjustments, and the checking and replacement of carburetor parts.

**Carburetor Construction**

360

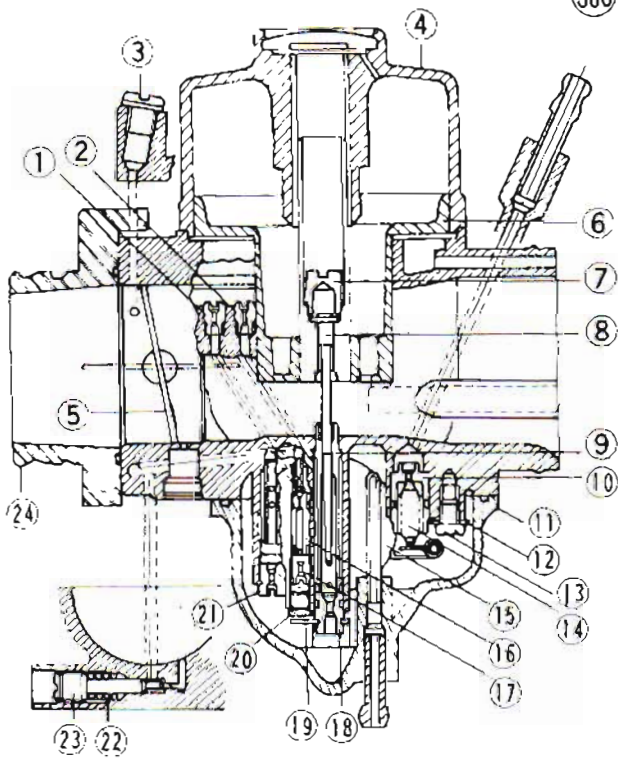

- |                      |                        |
|----------------------|------------------------|
| 1. Slow Air Jet      | 13. Screw              |
| 2. Main Air Jet      | 14. Float Valve Needle |
| 3. Vacuum Plug       | 15. Float              |
| 4. Carburetor Cap    | 16. Slow Jet           |
| 5. Butterfly Valve   | 17. Pilot Jet          |
| 6. Vacuum Piston     | 18. Main Jet           |
| 7. Screw             | 19. Jet Keeper         |
| 8. Jet Needle        | 20. Pilot Passage Plug |
| 9. Needle Jet        | 21. Starter Jet        |
| 10. Float Valve Seal | 22. Spring             |
| 11. Float Bowl       | 23. Pilot Screw        |
| 12. Retainer         | 24. Mounting Plate     |

A linkage mechanism turns each carburetor butterfly valve the same amount in response to throttle grip movement so that the carburetor operation is in unison. As the throttle grip is turned counterclockwise, the throttle accelerator cable turns the carburetor pulley, which through the linkage mechanism opens the butterfly valves. As the throttle grip is turned clockwise or is released, the linkage mechanism return spring together with the throttle decelerator cable closes the butterfly valves.

One of the basic principles in carburetor operation is that the pressure exerted by a moving body of air

is less than atmospheric pressure. As the engine draws air in through the carburetor bore, the air pressure in the carburetor bore is less than the air pressure in the float chamber, which is at atmospheric pressure. This difference in air pressure forces the fuel up through the passages into the carburetor bore where it is then atomized by the air, which is flowing at high speed to the engine.

Another important principle is the Venturi Principle, which states that when an air passage narrows, moving air flows faster, exerting even less pressure. For example, at low speeds (0 ~ ¼ throttle) the vacuum piston is at its lowest position, forming what is called the "primary venturi". Since the engine intake requires less air at lower engine speeds, there would not be enough air flow speed for sufficient fuel to be forced up through the jets unless the passage (carburetor bore) above the jets is constricted. The low position of the vacuum piston constricts this passage so that there will be sufficient air flow speed for pressure difference to force the necessary amount of fuel up through the jets.

Thus, the amount of fuel passing through a jet depends both on the size of the jet (variable in case of the needle jet) and on the speed of the air flow over the jet. The speed of this air flow is in turn determined both by the

**Venturi Principle**

361

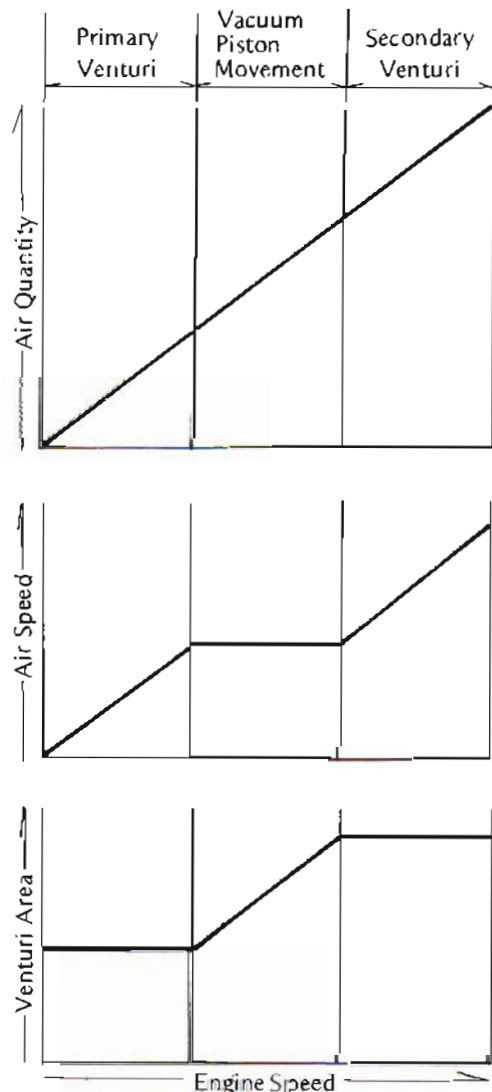

## 98 MAINTENANCE

• Table 2 Carburetor Specifications

Type	Main Jet	Main Air Jet	Slow Air Jet	Pilot Jet	Butterfly Valve Angle	Pilot Screw	Fuel Level
CVB36	125	60	90	35	10°30'	1½ ± ¼ turns out	33.5 mm

engine rpm and by the dimensions of the passage (variable by the vacuum piston) just above the jet. The size of the jet openings, the various dimensions of the air passages, and the engine rpm's are correlated through carburetor design so that, when properly adjusted, the carburetor meters (measures) the fuel and air in the correct proportions at different throttle openings.

The carburetor specifications (Table 2) have been chosen for best all around performance, and ordinarily will not require any change. However, sometimes an alteration may be desirable for improved performance under special conditions, and when proper mixture is not obtained after the carburetor has been properly adjusted and all parts cleaned and found to be functioning properly. For example, the quantity of air entering the carburetor bore is less at high altitude due to the lower atmospheric pressure. To obtain the proper carburetor fuel/air mixture, it may be necessary to exchange the main jet on each carburetor for one a size smaller. In particularly cold weather, the increased density of the air may necessitate a size larger main jet for each carburetor.

Since the carburetors regulate and mix fuel and air going to the engine, there are two general types of carburetor trouble: too rich a mixture (too much fuel) and too lean a mixture (too little fuel). Such trouble can be caused by dirt, wear, maladjustment, or improper fuel level in a float chamber. A dirty or damaged air cleaner can also alter the fuel to air ratio.

Table 3 Mixture Trouble Symptoms

Mixture too rich	Mixture too lean
Engine is sluggish	Engine overheats
Smoky exhaust	Runs better with choke lever pushed down
Runs less well when warm	Spark plug burned white
Spark plug fouled black	Running is unstable
Runs better without air cleaner	No power

The following explanation of the functioning and maintenance of the carburetors covers the four main systems for fuel regulation and supply: the starter system, which supplies the necessary rich mixture for starting the engine; the pilot system, which supplies fuel at idling and low speeds; the main system, which supplies fuel at medium and high speeds; and the float system, which maintains the fuel at a constant level in the float chambers.

### Starter System

Fig. 362 shows the starter system, which includes the starter jet (8), starter pipe (7), starter plunger (6), and starter air passage (9).

### Starter System

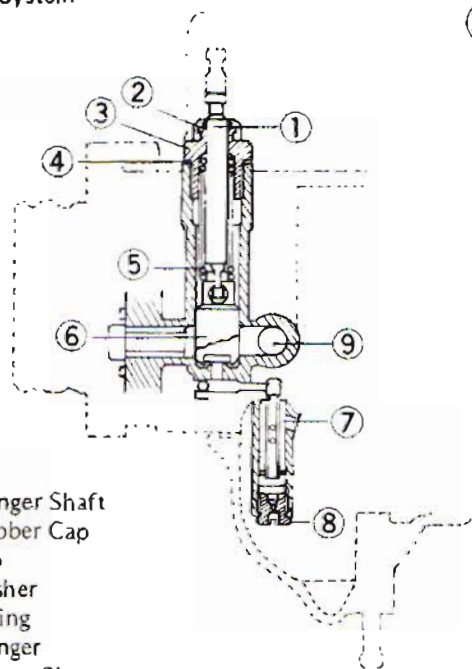

1. Plunger Shaft
2. Rubber Cap
3. Cap
4. Washer
5. Spring
6. Plunger
7. Starter Pipe
8. Starter Jet
9. Air Passage

The starter system is used for starting to provide the exceptionally rich 1:1 fuel/air ratio that is necessary to enable easy starting when the engine is cold. When starting the engine, the throttle is left closed, and the starter plunger is pulled fully open by pushing down the choke lever. Since the butterfly valve is closed, a high intake vacuum (low pressure or suction) is developed at the engine side of the carburetor bore. The starter plunger, when raised, opens up the starter passage and an air passage so that they connect to the engine side of the carburetor bore. The intake vacuum from the engine as it is cranked over draws in air through this air passage and the fuel from the float chamber through the starter passage. Fuel metered by the starter jet mixes with a small amount of air drawn in through air bleed holes in the starter pipe as it rises in the starter passage. This small amount of air prepares the fuel for better atomization once it reaches the plunger chamber (the area just below the raised plunger) where the fuel mixes with the air drawn in through the air passage. This mixture is then drawn into the carburetor bore where it, together with a small amount of mixture supplied by the pilot system, is drawn into the engine.

In order for the starter system to work properly, the throttle must be kept closed so that sufficient vacuum can be built up at the starter outlet. Also, the choke lever must be pushed down fully so that the starter plunger will fully open up the air passage and starter

passage to the carburetor bore. Clogged starter jet, starter pipe air bleed holes will cause insufficient atomization, thus impairing starter efficiency. Fuel mixture trouble results if, due to dirt, gum or a defective spring, the plunger does not seat properly in its rest position after the choke lever is returned.

**Cleaning**

Remove the float bowl, and blow the starter pipe, starter air passage, the starter jet clean with compressed air. Do not clean them with wire or any other hard object which may cause damage.

Remove the starter plunger, and clean it with a high flash point solvent of some kind.

**Pilot System**

Fig. 363 shows the pilot system, which includes the pilot jet (7), slow jet (5), slow air jet (1), pilot passage (4), pilot bypass (2), pilot screw (9), and pilot outlet (3).

**Pilot System**

(363)

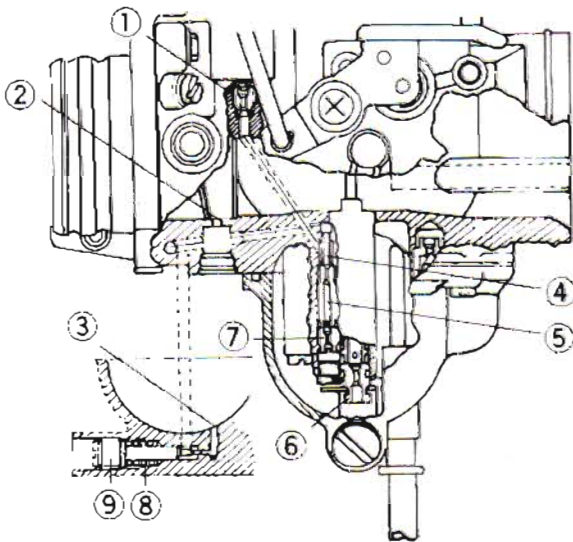

- |                 |                  |                |
|-----------------|------------------|----------------|
| 1. Slow Air Jet | 4. Pilot Passage | 7. Pilot Jet   |
| 2. Pilot Bypass | 5. Slow Jet      | 8. Spring      |
| 3. Pilot Outlet | 6. Main Jet      | 9. Pilot Screw |

The pilot system determines the operation of the carburetor from 0 to ¼ throttle opening. At small throttle openings, almost no fuel is drawn through the main system due to insufficient air flow. Instead, the fuel is drawn through the main, pilot, and slow jets as a result of the low pressure (suction) brought about by the demand for air by the engine and the limited but relatively fast flow of air past the pilot outlet. The almost closed position of the butterfly valve restricts the carburetor bore air flow, preventing it from relieving the low pressure created by the engine around

**Pilot System Fuel & Air Supply**

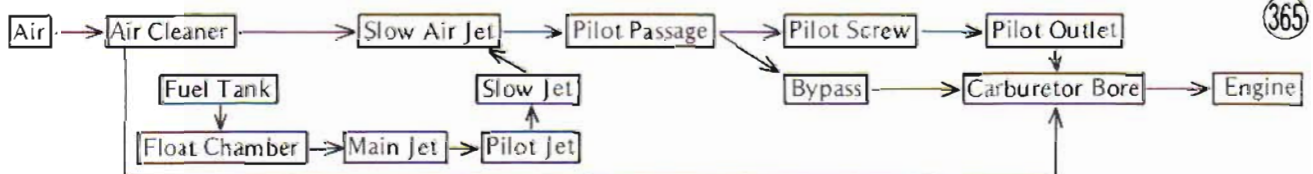

(365)

the pilot outlet while the Venturi effect (the narrower the air passage, the faster the flow of air) at the engine side of the butterfly valve further reduces the low pressure.

The supply of the fuel and air in the pilot system is shown in Fig. 365. At idling and slightly above, the fuel passes through the main jet, and is then metered at the pilot jet and at the slow jet, where the fuel mixes with air metered by the slow air jet. Then, the fuel passes through the pilot passage, where the pilot screw affects the flow, through the pilot outlet into the carburetor bore, and to the engine. As the butterfly valve turns a little more, the butterfly valve position extends the low pressure area to the pilot bypass, allowing fuel to bypass part of the pilot passage to go directly to the carburetor bore such that the supply of fuel increases sufficiently with engine need.

Fig. 364 shows throttle opening versus fuel flow for the main and pilot systems. If trouble occurs in the pilot system, not only are starting and low speed running affected, but the transition from pilot to main system is not smooth as the throttle is opened, causing a drop in engine efficiency. Pilot system trouble might be due to maladjustment; a dirty or loose pilot jet, slow jet, or slow air jet; or clogging of the main jet, pilot passage, pilot outlet, or pilot bypass.

**Flow Characteristic**

(364)

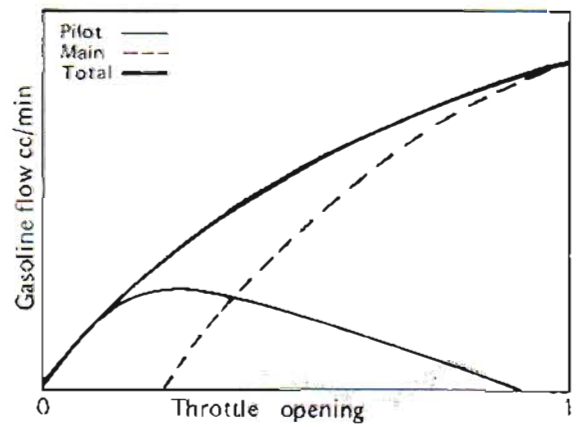

**Cleaning and replacement**

Wash the main jet, pilot jet, slow jet, and slow air jet with a high flash point solvent of some kind, and blow them clean with compressed air. Use compressed air to clean the pilot passage and slow air jet passage. Do not use wire for cleaning since any sharp instrument may cause damage.

Remove the pilot screw, and check that the tapered portion is not worn or otherwise deformed. If it is, replace the screw.

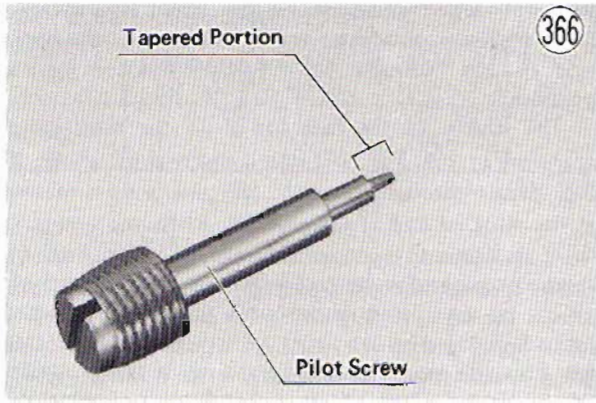

**Main System**

Fig. 367 shows the main system, which consists of the main jet ⑥, needle jet ⑤, jet needle ④, vacuum piston ③, and main air jet ①. Fig. 368 shows the supply of fuel and air in the main system.

From about ¼ throttle opening, the air flow past the jet needle outlet is sufficient to cause fuel to be drawn through the main system. The fuel passes through the main jet and then part of it goes through the pilot and slow jets as in the pilot system while the rest of it passes straight up through the space in the needle jet not blocked by the jet needle and into the carburetor bore, where it is atomized by the air flow to the engine.

**Main System**

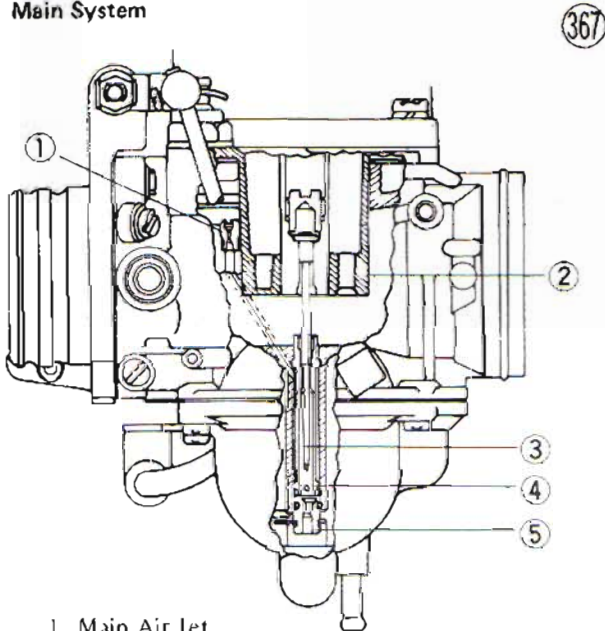

- 1. Main Air Jet
- 2. Vacuum Piston
- 3. Jet Needle
- 4. Needle Jet
- 5. Main Jet

**Main System Fuel & Air Supply**

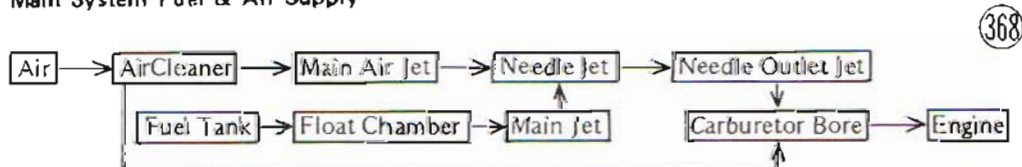

The needle jet has holes to admit the air metered by the main air jet. This air mixes with the fuel in the needle jet to prepare the fuel for better atomization in the carburetor bore.

The lower part of the jet needle is tapered and extends down into the needle jet. It is fixed to the vacuum piston, and thus rises up in the needle jet as the vacuum piston rises. From the time the vacuum piston starts rising, from about ¼ throttle, until it reaches most of the way up in the carburetor bore, the fuel is metered primarily by the jet needle taper. As the jet needle rises, the needle to jet clearance increases, thereby increasing the amount of fuel that can pass up through the jet.

The vacuum piston rises only between ¼ and ¾ throttle. Through the hole in the bottom of the piston, the air pressure in the chamber above the vacuum piston is reduced by engine intake. Through another hole, the pressure of the incoming fuel/air mixture is transmitted to the piston. As engine speed increases, the air pressure in the upper chamber decreases, and the difference between the incoming fuel/air mixture pressure and the upper chamber air pressure will overcome the force of the weight of the piston, raising the piston to the extent corresponding to the pressure difference.

As shown in Fig. 361 the quantity of air drawn in by the engine intake is in direct proportion to engine rpm, and the speed of the air flow is constant while the vacuum piston rises from ¼ to ¾ throttle. Were the size of the air passage above the needle jet to change simultaneously with throttle movement rather than with engine intake (demand), the speed of the air flow in the air passage might even drop during a rapid increase in throttle due to the Venturi effect, causing a slight stall in acceleration. However, the vacuum piston-butterfly valve arrangement controls both the air and fuel supply at sudden throttle for smooth and immediate engine response.

At ¾ throttle the vacuum piston reaches its highest position, forming the "secondary venturi" to permit maximum engine output. At near full throttle openings, the cross-sectional area of the needle to jet clearance becomes greater than the cross-sectional area of the main jet. At these openings, the fuel drawn up into the carburetor bore is limited by the size of the main jet rather than the needle to jet clearance.

Trouble in the main system is usually indicated by poor running or lack of power at high speeds. A dirty or clogged main jet will cause the mixture to become too lean. An overly rich mixture could be caused by clogging of the main air jet, its air passage, or the air holes in the needle jet; by needle jet or needle wear (increasing clearance); by a loose main jet; or by a loose needle jet.

**Cleaning and adjustment**

Disassemble the carburetor, and wash the vacuum piston, main jet, needle jet, jet needle, main air jet, and air passage with a high flash point solvent of some kind, blowing them clean with compressed air. Do not use wire for cleaning since a sharp instrument may cause damage.

**Jet Needle**



369

If the engine still exhibits symptoms of overly rich or lean carburetion after all maintenance and adjustments are correctly performed, the main jet may be replaced with a smaller or larger one. A smaller numbered jet gives a leaner mixture and a larger numbered jet a richer mixture. Many jets are available, but it is recommended that any change be limited to one jet size (10) difference from the standard jet.

**Float System**

Fig. 370 shows the float system, which consists of the float (4), float valve needle (3), and float valve seat (1).

The float system serves to keep a more or less fixed level of fuel in the carburetor float chamber at all times so that the fuel mixture to the engine will be stable. If the fuel level in the float chamber is set too low, it will be more difficult for fuel to be drawn up into the carburetor bore, resulting in too lean a mixture. If the level is set too high, the fuel can be drawn up too easily, resulting in too rich a mixture.

The fuel level is defined as the vertical distance from the center of the carburetor bore to the surface of the fuel in the float chamber. The fuel level is maintained at a constant value by the action of the float valve, which opens and closes according to the fuel level. As fuel flows through the float valve into the chamber, the fuel level rises. The float, rising with the fuel level, pushes up on the needle. When the fuel reaches a certain level, the needle is pushed completely into the valve seat, which closes the valve so that no more fuel may enter the chamber. As the fuel is drawn up out of the float chamber, the fuel level drops, lowering the float. The needle no longer blocks the float valve, and fuel once again flows through the float valve into the chamber.

**Float System**

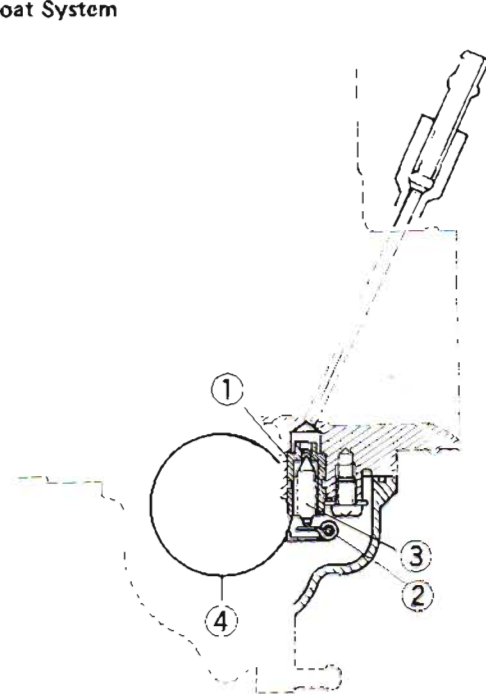

370

- 1. Float Valve Seat
- 2. Float Pin
- 3. Float Valve Needle
- 4. Float

**Fuel level measurement and adjustment**

Turn the fuel tap off, and remove the drain plug from the bottom of the float bowl. Install the fuel level gauge (special tool). Hold the plastic tube against the carburetor body, and turn on the fuel tap. The fuel level in the plastic tube should come up to 2 ~ 4 mm below the edge of the carburetor body.

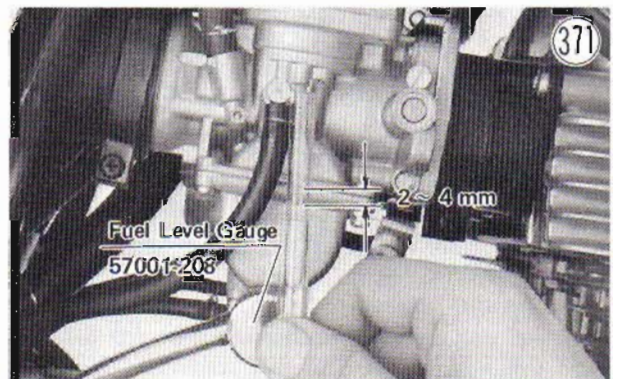

371

If the fuel level is incorrect, remove the float bowl and float. Bend the tang on the float a very slight amount to change the fuel level. Bending it up closes the valve sooner and lowers the fuel level; bending it down raises the level.

After adjustment, measure the fuel level again, and readjust if necessary.

Fuel Level Measurement

372

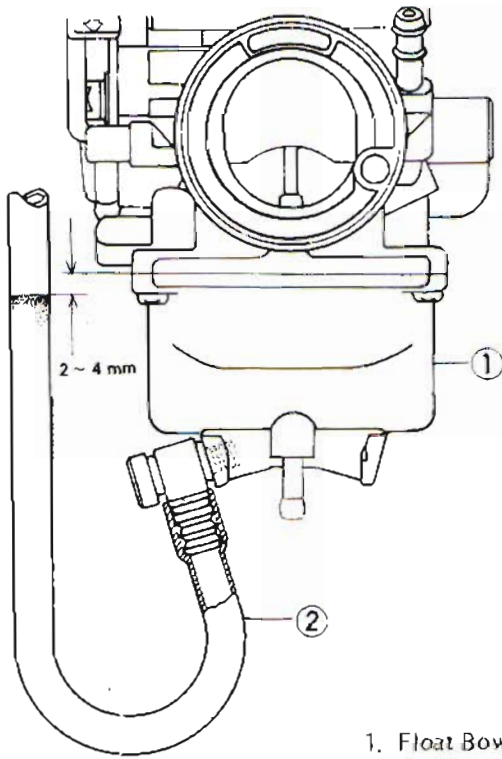

- 1. Float Bowl
- 2. Fuel Level Gauge

Needle Valve

374

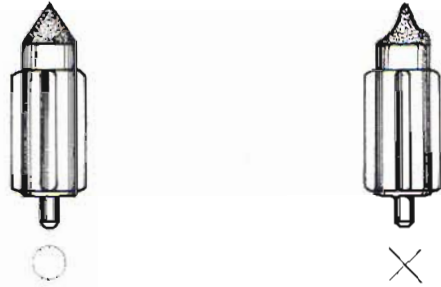

CAMSHAFT

The engine has an overhead camshaft (OHC) at the top of the cylinder head. The camshaft has four cams, two for the two inlet valves and two for the two exhaust valves. At the center of the camshaft is the camshaft sprocket. The sprocket is marked with arrows, which are referred to during camshaft installation for easily and correctly resetting the valve timing.

Engine rotation is transmitted from the crankshaft to the camshaft by a chain running on a sprocket at the center of each shaft. As the camshaft rotates, the cams move against the rocker arms, which open and close the inlet and exhaust valves at the proper intervals (Fig. 375).

Valve Timing

375

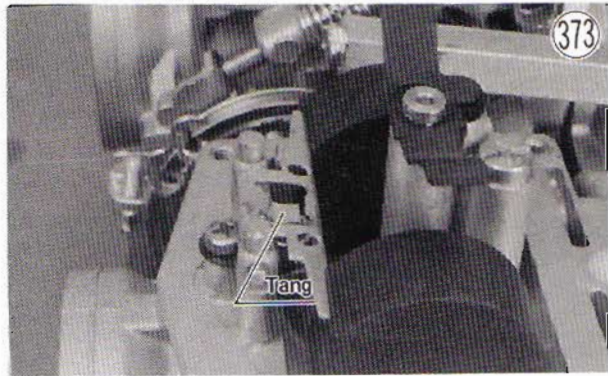
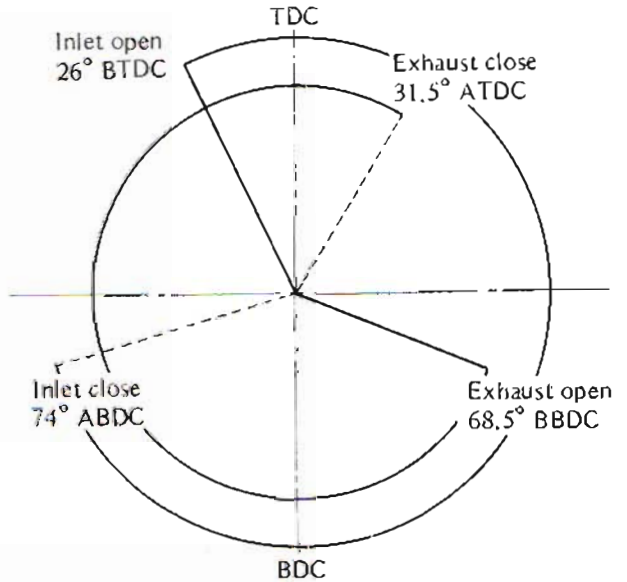

Cleaning and replacement

If dirt gets between the needle and seat, the float valve will not close and fuel will overflow. Overflow can also result if the needle and seat become worn. If the needle sticks closed, no fuel will flow into the carburetor.

Take off the float bowl and float. Wash the bowl and float parts in a high flash point solvent of some kind. Use carburetor cleaner if necessary. Blow out the fuel overflow pipe with compressed air.

Examine the float, and replace if damaged. If the needle is worn as shown in the diagram, replace the needle and seat as a set.

However, since the time, amount, and duration that each valve is opened (valve timing) changes with cam wear, journal wear, and camshaft runout (bend), the camshaft should be inspected periodically and whenever timing trouble is suspected. If the valves do not open at the right times or if they do not open the correct amount or duration, there will be a decrease in combustion efficiency, dropping engine power and leading to serious engine trouble.

**Cam wear**

Remove the camshaft, and measure the height of each cam with a micrometer. If the cams are worn down past the service limit, replace the camshaft.

**Cam Wear Measurement**

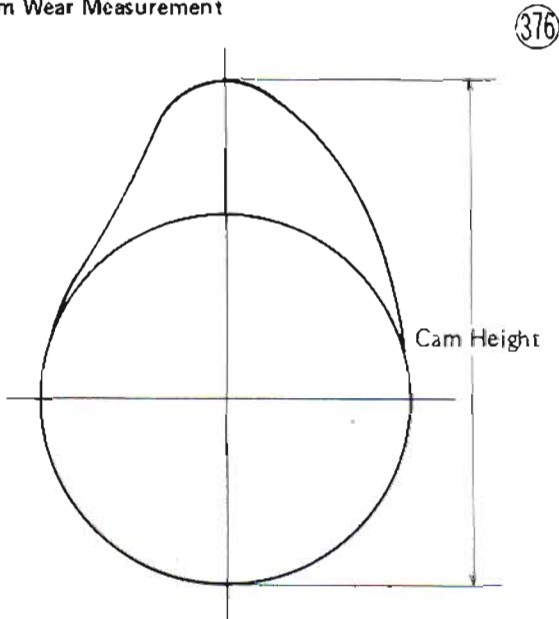

**Table 4 Cam Height**

Standard	Service Limit
22.41 ~ 22.45 mm	22.3 mm

**Journal wear**

The journal wear is measured using a plastigauge (press gauge), which is inserted into the clearance to be measured. The plastigauge indicates the wear by the amount it is compressed and widened when the parts are assembled.

Remove the cylinder head cover, cut strips of plastigauge to journal width, and place a strip on each journal parallel to the camshaft and so that the plastigauge will be compressed between the journal and the cylinder head cover. Replace the cylinder head cover, tightening the stud nuts in the correct sequence with the correct amount of torque (Pg. 175).

Remove the cylinder head cover, and measure the plastigauge width to determine the clearance between each journal and the cylinder head cover. If a clearance exceeds the service limit, replace the camshaft.

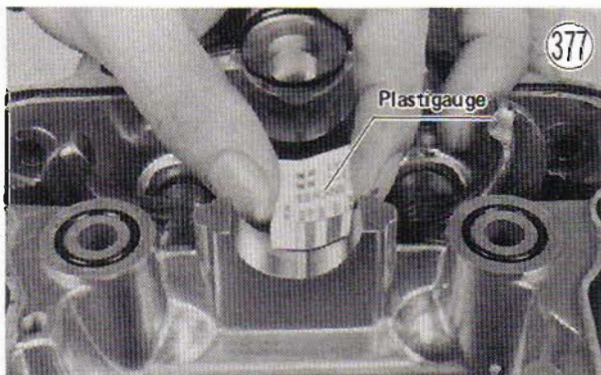

**\*Table 5 Camshaft Journal/Cylinder Head Cover Clearance**

Standard	Service Limit
0.043 ~ 0.101 mm	0.19 mm

Measure the diameter of each camshaft journal with a micrometer. If a diameter is less than the service limit, replace the camshaft.



**\*Table 6 Camshaft Journal Diameter**

Standard	Service Limit
27.94 ~ 27.96 mm	27.90 mm

**Camshaft runout**

Remove the camshaft, and take the sprocket off the shaft. Set the shaft in V blocks at the journals as shown in the figure. Measure the runout with a dial gauge set to where the sprocket is mounted on the shaft. If the runout exceeds the service limit, replace the camshaft.

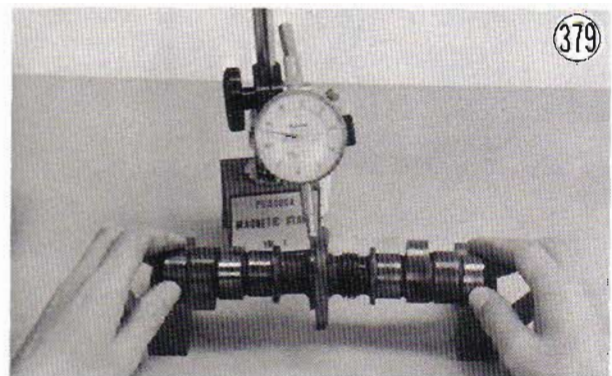

**Table 7 Camshaft Runout**

Standard	Service Limit
under 0.02 mm	0.1 mm

**CAMSHAFT CHAIN & CHAIN GUIDES**

The camshaft chain, which is driven by the crankshaft sprocket, drives the camshaft at one half of the crankshaft rpm. For maximum durability, it is an endless-type chain with no master link.

## 104 MAINTENANCE

Camshaft chain, sprocket, and chain guide wear cause noise, accelerate wear, and could possibly lead to serious damage to the engine. If the chain tension can no longer be adjusted by the chain tensioner, either the camshaft chain or the chain guides must be replaced.

### Camshaft chain wear

Remove the camshaft chain, hold the chain taut with a force of about 5 kg in some manner such as the one shown in Fig. 380, and measure a 20-link length. If the chain has lengthened beyond the service limit, replace it for a new one.

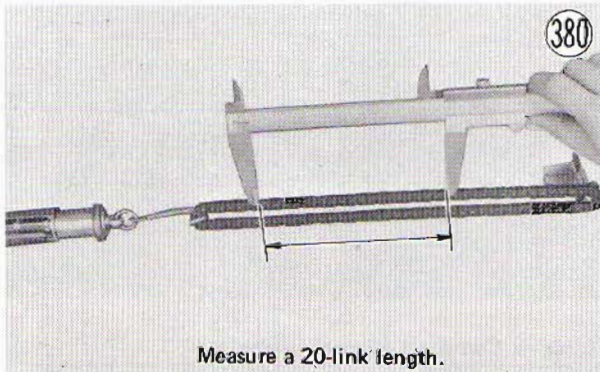

Table 8 Camshaft Chain Wear

Standard	Service Limit
160 mm	162.4 mm

### Chain guide wear

Remove the chain guides, and inspect them visually. Replace if the rubber or any other portion is damaged.

Measure the thickness with a ruler. Replace if the wear has exceeded the service limit.

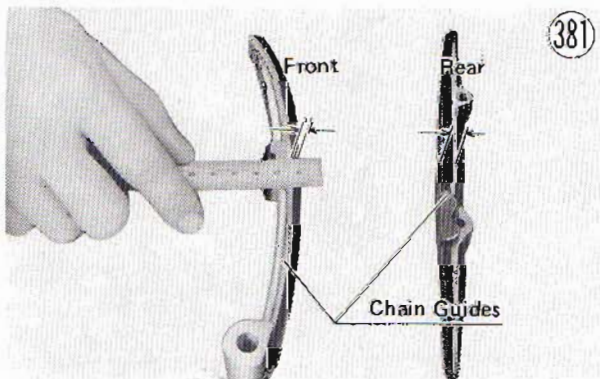

Table 9 Chain Guide Wear

	Standard	Service Limit
Front	3.3 mm	1.5 mm
Rear	4.5 mm	2 mm

## ROCKER ARMS, SHAFTS

There are four rocker arms and shafts in the cylinder head cover. The two arms and shafts to the front control the two exhaust valves, while the two to the rear control the two inlet valves. The rocker arms are made of a special steel alloy for durability, and each arm surface which makes contact with the cam and the valve stem has been heat-treated to achieve superior surface hard-

ness. An oil hole in each rocker arm enables oil to lubricate between the arm and shaft.

Excessive clearance between a rocker arm and shaft results in engine noise.

### Rocker arm wear

Visually inspect where the cam and valve stem wear on each arm. If there is any damage or uneven wear, replace the arm.

Measure the inside diameter of each arm with a cylinder gauge. If it exceeds the service limit, replace the arm.

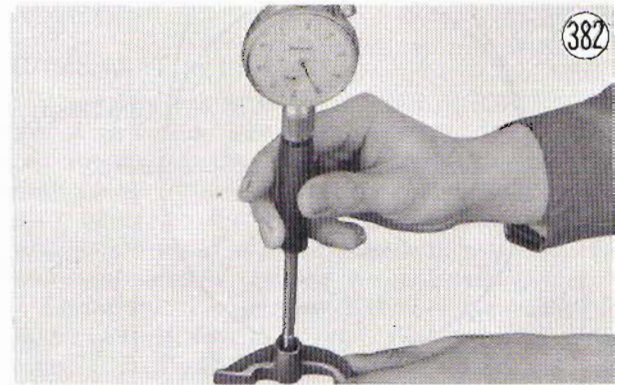

Table 10 Rocker Arm Inside Diameter

Standard	Service Limit
13.000~13.018 mm	13.05 mm

### Rocker shaft wear

Measure the diameter of each shaft where the arm fits. If the diameter is less than the service limit, replace the shaft.

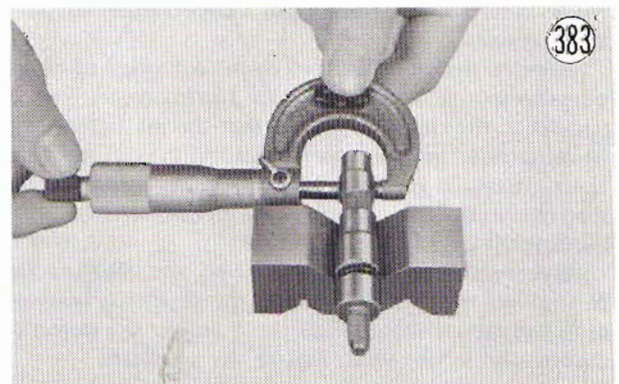

Table 11 Rocker Shaft Diameter

Standard	Service Limit
12.966~12.984 mm	12.94 mm

## CYLINDER HEAD, VALVES

The valves, mounted in the cylinder head, are pushed open by the rocker arms and closed by the valve springs.

The valve guides are pressed into the cylinder head, while the valve seats are cast in. The valve seats are cut to the angles shown in Fig. 384 in order that the seats

match the valve seating surfaces perfectly flush not only to prevent compression leakage but also to provide efficient heat transmission.

**Cutting Angle of Valve Seat**

384

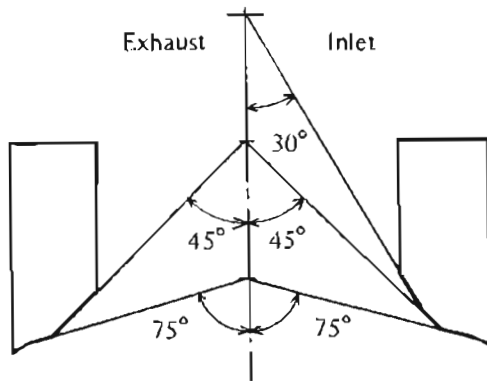

**Cylinder Head**

The cylinder head is made of aluminum alloy, used for its high heat conductivity, and is finned on the outside to aid dissipation of the heat generated in the combustion chambers. Carbon built up inside the combustion chambers interferes with heat dissipation and increases the compression ratio, which may result in preignition, detonation, and overheating. Trouble can also come from improper head mounting or mounting torque, causing compression leakage.

**Cleaning and inspection**

Remove the cylinder head (Pg. 34). Scrape out any carbon, and wash the head with a high flash point solvent of some kind.

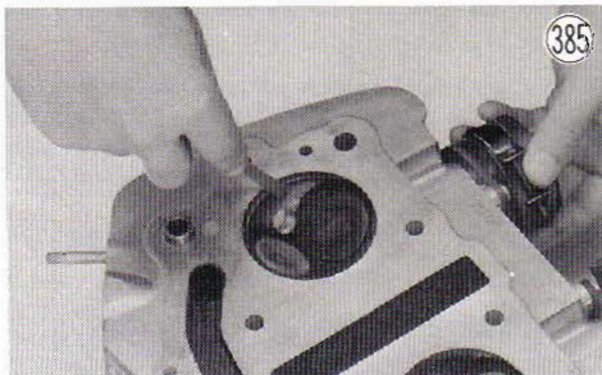

Lay a straight edge across the lower surface of the head at several different points, and measure warp by inserting a thickness gauge between the straight edge and the head.

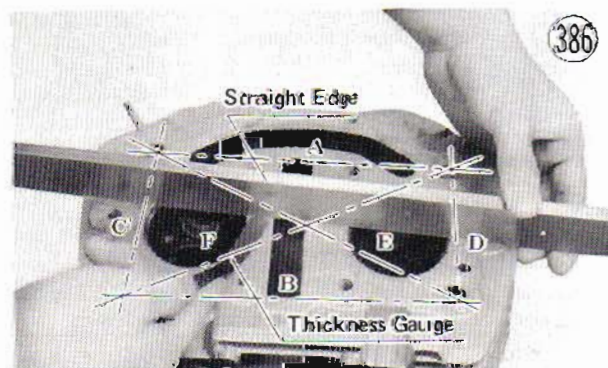

If warp exceeds the service limit, replace the cylinder head.

Table 12 Cylinder Head Warp

Standard	Service Limit
under 0.05 mm	0.25 mm

**Valve, Valve Guide, Valve Seat**

Valve face deformation or wear, stem bending or wear, and valve guide wear are all causes of poor valve seating. Poor seating can also be caused by the valve seat itself through heat damage or carbon build-up. The result of poor seating is compression leakage and a loss of engine power.

In addition, valve and valve seat wear causes deeper valve seating and a decrease in valve clearance. Insufficient clearance upsets valve timing and may eventually prevent the valve from seating fully. So that the wear never progresses this far, adjust the valve clearance in accordance with the periodic maintenance chart (Pg. 172).

**Valve inspection**

Visually inspect the valve face, and replace the valve if it shows deformation or uneven wear.

Measure the thickness of the valve head using vernier calipers, and replace the valve together with its valve guide if the thickness is under the service limit.

**Valve Shape**

387

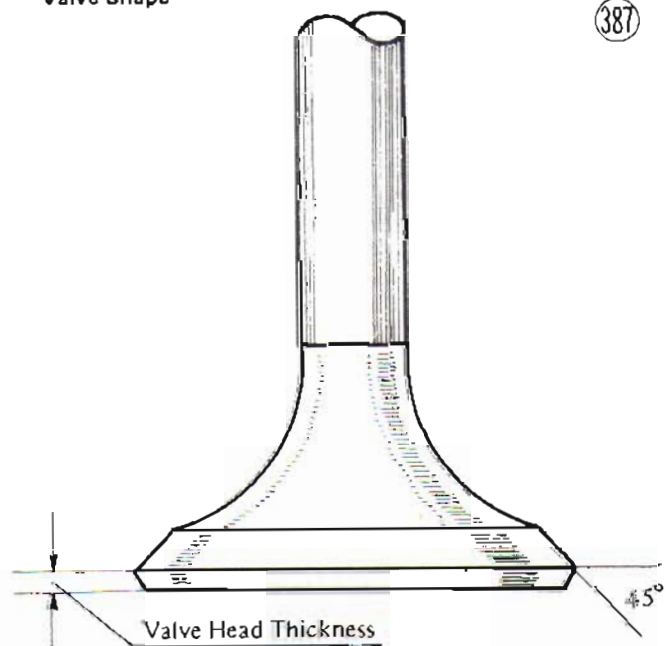

Table 13 Valve Head Thickness

Standard	Service Limit
0.75~1.25 mm	0.5 mm

If the seating surface of the valve or the end of the valve stem is damaged or badly worn, repair the valve with a valve refacer. The angle of the seating surface is 45°.

Valve Stem Grinding

388

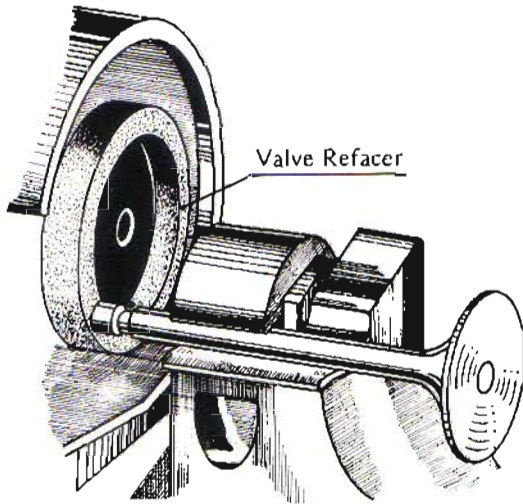

**CAUTION:** If the valve stem is ground down, be sure to leave at least 4.2 mm of stem end above the wide groove portion.

Turn the valve in a V block using a dial gauge as shown to measure the amount that the stem is bent. Replace the valve if it is bent over the service limit.

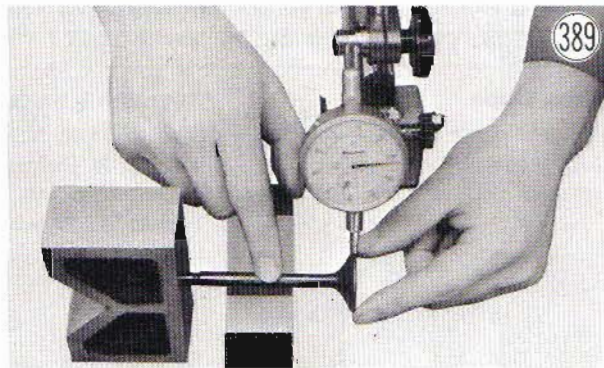

Table 14 Valve Stem Bend

Service Limit
0.05 mm

Measure the diameter of the valve stem with a micrometer. Since the stem wears unevenly, take measurements at four places up and down the stem, keeping the micrometer at right angles to the stem.

Replace the valve if the stem is worn to less than the service limit.

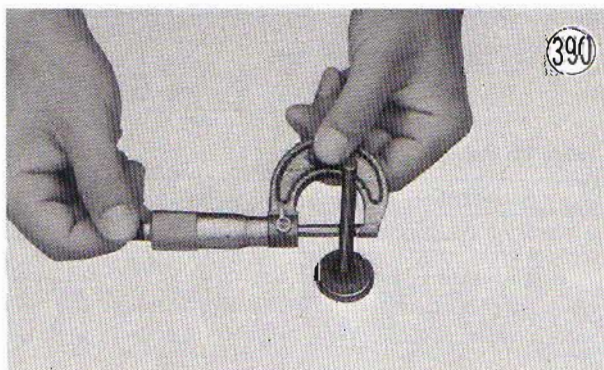

Table 15 Valve Stem Diameter

	Standard	Service Limit
Inlet	6.965 ~ 6.980 mm	6.86 mm
Exhaust	6.955 ~ 6.970 mm	6.85 mm

Valve guide inspection

Remove the valve, and measure the inside diameter of the valve guide using a small bore gauge and micrometer. Since the guide wears unevenly, measure the diameter at four places up and down the guide. If any measurement exceeds the service limit, replace the guide.

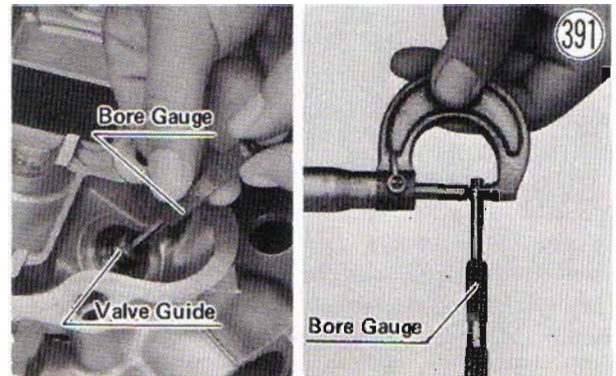

Table 16 Valve Guide Inside Diameter

Standard	Service Limit
7.000~7.015 mm	7.10 mm

If a small bore gauge is not available, insert a new valve into the guide, set a dial gauge against the stem, and move the stem back and forth to measure valve/guide clearance. Repeat the measurement in a direction at a right angle to the first.

If the valve/guide clearance exceeds the service limit, replace the guide.

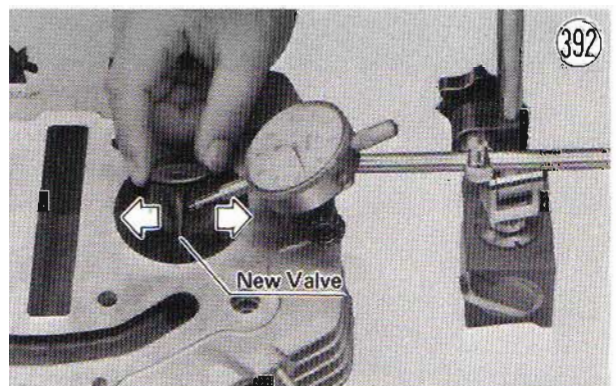

Table 17 Valve/Guide Clearance

	Standard	Service Limit
Inlet	0.02~0.05 mm	0.1 mm
Exhaust	0.03~0.06 mm	0.1 mm

**Valve seat repair**

The valve must seat in the valve seat evenly around the circumference over a 0.5 ~ 1.0 mm wide area. If the seat is too wide, the seating pressure per square unit of area is reduced, possibly resulting in compression leakage and carbon accumulation on the seating surface. If the seating area is too narrow, heat conduction from the valve is reduced, and the valve will overheat and warp. Uneven seating or seat damage will cause compression leakage.

To determine whether or not the valve seat requires repair, first remove the valve, apply machinist's dye to the valve seat, and then use a lapper to tap the valve lightly into place. Remove the valve, and note where the dye adheres to the valve seating surface. The distribution of the dye on the seating surface gives an indication of seat condition.

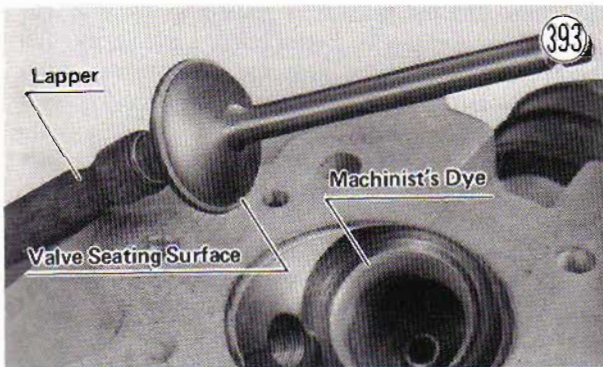

**NOTE:** The valve and valve guide must be in good condition before this check will give an accurate indication of valve seat condition.

A valve seat which requires repair is cut with a set of valve seat cutters. Four cutters are required for complete repair; one 30° (inlet valve seat only); one 45°; and two 75° cutters, one for the inlet and the other for the exhaust.

First, cut the seating surface of the valve seat with the 45° cutter. Cut only the amount necessary to make a good surface; overcutting will reduce the valve clearance, possibly making it no longer adjustable.

**Valve/Valve Seat Contact Area**

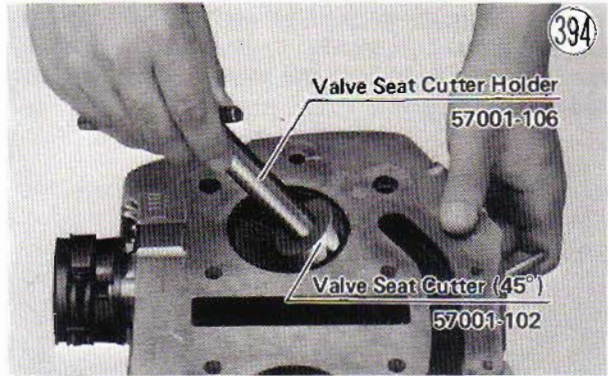
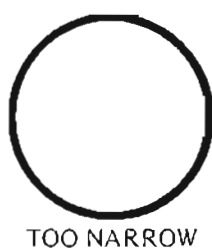
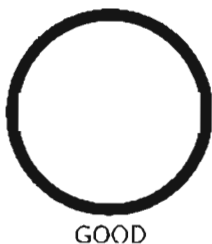

Next, use the 30° cutter (inlet valve seat only) to cut the surface inside the seating surface, and then use the 75° cutter to cut the outermost surface. Cut these two surfaces so that the seating surface will be 0.5 ~ 1.0 mm wide.

After cutting, lap the valve to properly match the valve and valve seat surfaces so that the valve will seat well. Start off with coarse lapping compound, and finish with fine compound.

Apply compound to the valve seat, and tap the valve lightly into place while rotating it with a lapper, repeating this until a smooth, matched surface is obtained.

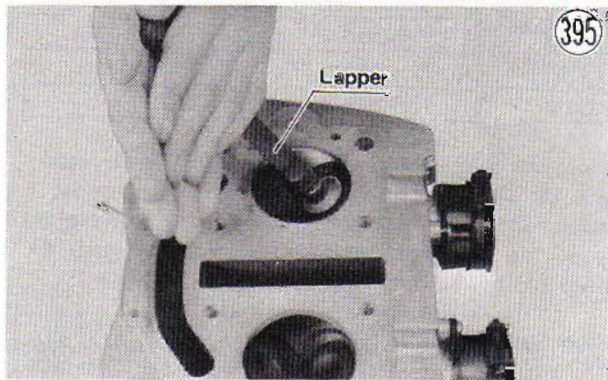

When lapping is completed and the valves are installed, check the valve clearance and adjust if necessary (Pg. 14).

**Valve Springs**

When the valve is not being pushed open by the rocker arm, valve springs press the valve against the seat to prevent compression leakage. An inner spring

## 108 MAINTENANCE

and an outer spring are used for each valve to prevent spring bounce at high speeds. If the springs weaken or break, compression leakage and valve noise will result, dropping engine power.

### Inspection

Remove the springs, and check the free length of each spring with vernier calipers. Replace any spring which is shorter than the service limit.

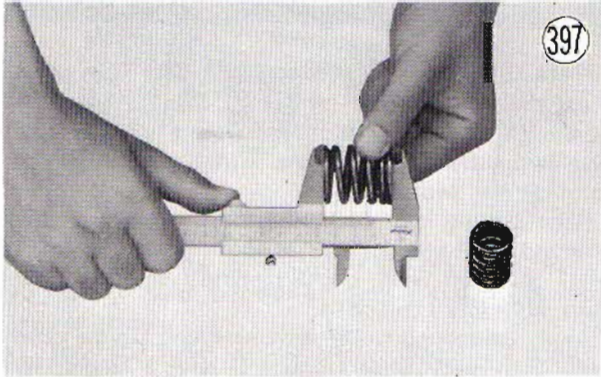

Table 18 Valve Spring Free Length

	Standard	Service Limit
Inner	32.4 mm	31.0 mm
Outer	37.3 mm	36.0 mm

Measure the perpendicularity of each spring by standing it on a surface plate and setting a square against it. Replace any spring for which the distance between the top of the spring and the square is greater than the service limit.

### Valve Spring Perpendicularity

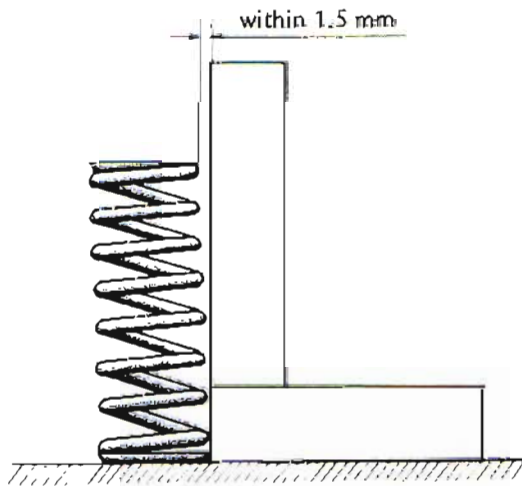

Table 19 Valve Spring Perpendicularity

	Standard	Service Limit
Inner	0.85 mm	1.5 mm
Outer	0.98 mm	1.5 mm

### Oil Seals

The oil seal around each valve stem prevents oil from leaking down into the combustion chamber. If an oil seal is damaged or deteriorated, oil consumption will increase, carbon may build up in the combustion chambers, and white smoke may come out of the exhaust.

If the oil seal appears damaged or deteriorated or if there is any doubt as to its condition, replace it for a new one.

## CYLINDER BLOCK, PISTONS

The cylinder block is subjected to extremely high temperatures. Since excessive heat can seriously distort the shape of a cylinder or cause piston seizure, the cylinder block is made of aluminum alloy for good heat conduction and the outside is finned to increase the heat radiating surface for better cooling efficiency. To minimize distortion from heat and to maximize durability, a heat durable, wear resistant sleeve is cold pressed in each cylinder.

Each piston is made from an aluminum alloy, which expands and distorts slightly from heat during engine operation. So that the piston will become cylindrical after heat expansion, it is designed such that, when cold, it is tapered in towards the head and is elliptical rather than perfectly round. The piston diameter is made so that there is enough clearance between the piston and cylinder to allow for expansion.

Three rings are fitted into grooves near the top of each piston to prevent compression leakage into the crankcase and to stop oil from getting up into the combustion chambers. The top two rings are compression rings, and the bottom ring is an oil ring.

The full floating type of piston pin is used to connect each piston to its con-rod. The middle part of the piston pin passes through the small end of the con-rod, and a snap ring is fitted at each end of the piston pin in a groove to prevent the pin from coming out. Since the pin is the full floating type, a small amount of clearance exists between the piston pin and the piston when the engine is at normal operating temperatures.

Proper inspection and maintenance of the cylinder block and the pistons include checking the compression; removing carbon from the piston heads, piston ring grooves, and cylinder head exhaust ports; and checking for wear and proper clearance during top end overhaul. A worn cylinder, worn piston, or worn or stuck piston rings cause a loss of compression from gas blowby pass the rings since the rings will not form a satisfactory seal between the piston and the cylinder wall during compression. This gas blowby will result in difficult starting, power loss, excessive fuel consumption, contaminated engine oil, and possibly engine destruction. Oil leakage into the combustion chambers causes carbon to build up on top of the pistons, resulting in preignition, overheating, and detonation. A worn piston pin causes piston slap, which will result in accelerated piston and cylinder wear.

Engine problems may be caused not only by carbon deposits and wear or damage to the engine itself, but also by poor quality fuel or oil, improper oil, improper fuel/air mixture, improper supply of oil, or incorrect ignition timing. Whenever knocking, pinging, piston slap, or other abnormal engine noise is heard, the cause should be determined as soon as possible. Neglect of proper maintenance will result in reduced engine power and may lead to accelerated wear, overheating, detonation, piston seizure, and engine destruction.

**Compression measurement**

A compression test is very useful as an aid in determining the condition of the engine. Low compression may be due to cylinder wear; worn piston ring grooves; worn, broken, or sticking piston rings; poor valve seating; cylinder head leaks; or damage to the engine such as piston seizure. Too high a compression may be due to carbon build-up on the piston heads and cylinder head. Difference in compression between the cylinders may cause poor running.

Before measuring compression, check that the cylinder head is tightened down with the correct torque (Pg. 176), and thoroughly warm up the engine so that engine oil between the pistons and cylinder walls will help seal compression as it does during normal running. While the engine is running, check that there is no gas leakage from around the cylinder head gasket.

Stop the engine, remove the spark plugs, and push the compression gauge (special tool) firmly into the spark plug hole for the cylinder in which the compression is to be measured such that there will be no leakage. Turn the engine over with the throttle fully open until the compression gauge stops rising; the compression is the highest reading obtainable.



**Table 20 Cylinder Compression**

Standard	Service Limit
10~11 kg/cm <sup>2</sup> (142~156 psi)	7.5 kg/cm <sup>2</sup> (107 psi) and less than 1 kg/cm <sup>2</sup> (14 psi) difference between the cylinders.

**Cylinder, piston wear**

Since there is a difference in cylinder wear in different directions, take a side to side and a front to back measurement at each of the 3 locations (total of 6 measurements) shown in Fig. 401. If any of the cylinder inside diameter measurements exceeds the service limit, or if there is a difference of more than

0.05 mm between any two measurements, the cylinder will have to be bored to oversize and then honed. However, if the amount of boring necessary would make the inside diameter greater than 64.98 mm, the cylinder block must be replaced.

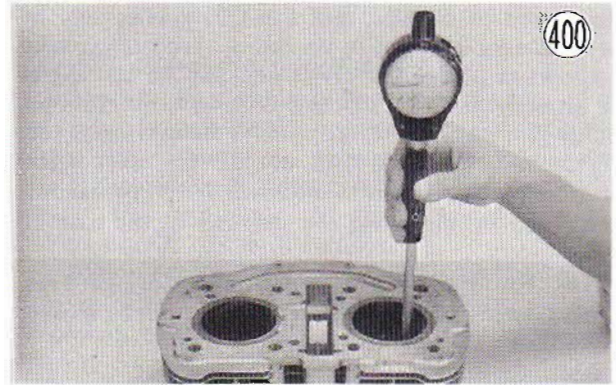

**Cylinder Inside Diameter Measurement**

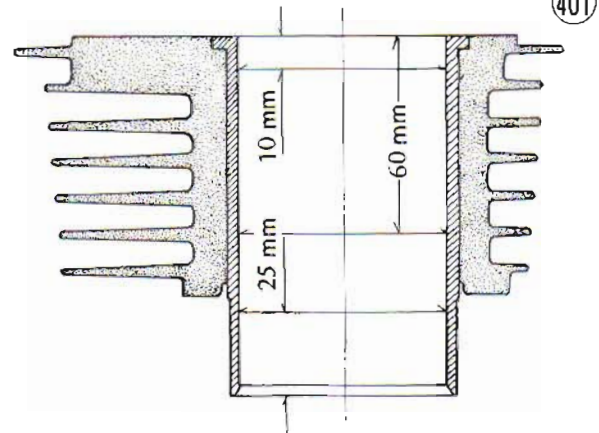

**Table 21 Cylinder Inside Diameter**

Standard	Service Limit
63.984~64.004 mm	64.08 mm

Measure the outside diameter of each piston 5 mm up from the bottom of the piston at a right angle to the direction of the piston pin. If the measurement is under the service limit, replace the piston.

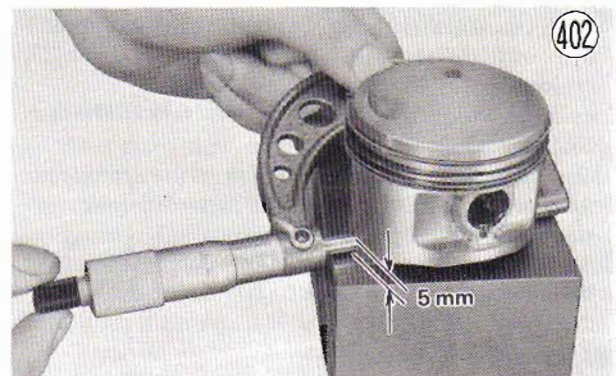

**NOTE:** Abnormal wear such as a marked diagonal pattern across the piston skirt may mean a bent con-rod or crankshaft.

## 110 MAINTENANCE

**Table 22 Piston Diameter**

Standard	Service Limit
63.94~63.96 mm	63.8 mm

Table 21 applies only to a cylinder that has not been bored to oversize, and Table 22 applies only to the standard size piston. In the case of a rebored cylinder and oversize piston, the service limit for the cylinder is the diameter that the cylinder was bored to plus 0.1 mm and the service limit for the piston is the oversize piston original diameter minus 0.15 mm. If the exact figure for the rebored diameter is unknown, it can be roughly determined by measuring the diameter at the base of the cylinder.

**NOTE:** Whenever the piston or cylinder block has been replaced for a new one, the motorcycle must be broken in the same as with a new machine.

### Piston/cylinder clearance

The piston to cylinder clearance is measured whenever a piston or the cylinder block is replaced for a new one, or whenever a cylinder is rebored and an oversize piston installed. The standard piston to cylinder clearance must be adhered to whenever the cylinder block is replaced or a cylinder rebored. However, if only a piston is replaced, the clearance may exceed the standard slightly, but it must not be less than the minimum in order to avoid piston seizure.

The most accurate way to find the piston clearance is by making separate piston and cylinder diameter measurements and then computing the difference between the two values. Measure the piston diameter as just described, and measure the cylinder diameter at the very bottom of the cylinder.

**Table 23 Piston/Cylinder Clearance**

Standard
0.034~0.054 mm

### Boring, honing

When boring and honing a cylinder, note the following:

1. Before boring a cylinder, first measure the exact diameter of the oversize piston, and then, in accordance with the standard clearance given in Table 23, determine the diameter of the bore.
2. Cylinder inside diameter must not vary more than 0.01 mm at any point.
3. There are two sizes of oversize pistons available: 0.5 mm and 1.0 mm. Oversize pistons require oversize rings.
4. Be wary of measurements taken immediately after boring since the heat affects cylinder diameter.

### Piston/cylinder seizure

Remove the cylinder block and pistons to check the damage. If there is only slight damage, the piston may be smoothed with #400 emery cloth, and any aluminum deposits removed from the cylinder with either #400

emery cloth or light honing. However, in most cases, the cylinder will have to be bored to oversize and honed, and an oversize piston installed.

### Piston cleaning

As carbon on the piston top reduces piston cooling efficiency, scrape off any accumulated carbon.



Clean carbon and dirt out of the piston ring grooves using a piece of broken piston ring or some other suitable tool.

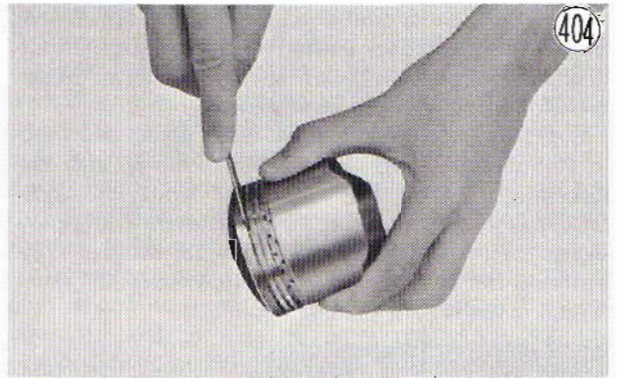

### Piston ring, piston ring groove wear

Visually inspect the piston rings and the piston ring grooves. If the rings are worn unevenly or damaged, they must be replaced. If the piston ring grooves are worn unevenly or damaged, the piston must be replaced and fitted with new rings.

Measure the width of the ring grooves, and measure the thickness of the rings. If the width of the grooves exceeds the service limit, replace the piston. Replace any rings that are worn down to less than the service limit.

**Table 24 Piston Ring Thickness**

	Standard	Service Limit
Top ring	1.460~1.475 mm	1.38 mm
Second ring	1.475~1.490 mm	1.40 mm
Oil ring	2.475~2.490 mm	2.40 mm

**Table 25 Piston Ring Groove Width**

	Standard	Service Limit
Top ring	1.50~1.52 mm	1.60 mm
Second ring	1.50~1.52 mm	1.60 mm
Oil ring	2.50~2.52 mm	2.60 mm

Even though both the piston ring grooves and piston rings may be in tolerance, parts will have to be replaced if the ring/groove clearance exceeds the service limit.

With the piston rings fitted into place on the piston, make several clearance measurements around the grooves using a thickness gauge.

**Table 26 Piston Ring/Groove Clearance**

	Standard	Service Limit
Top ring	0.025~0.060 mm	0.160 mm
Second ring	0.010~0.045 mm	0.145 mm
Oil ring		

**Piston ring end gap**

Place the piston ring being checked inside the cylinder using the piston to locate the ring squarely in place. Set it close to the bottom of the cylinder, where cylinder wear is low. Measure the gap between the ends of the ring with a thickness gauge. If the gap is wider than the service limit, the ring is overworn and must be replaced.

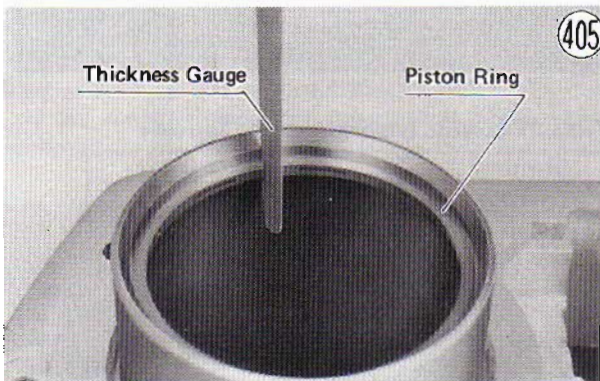
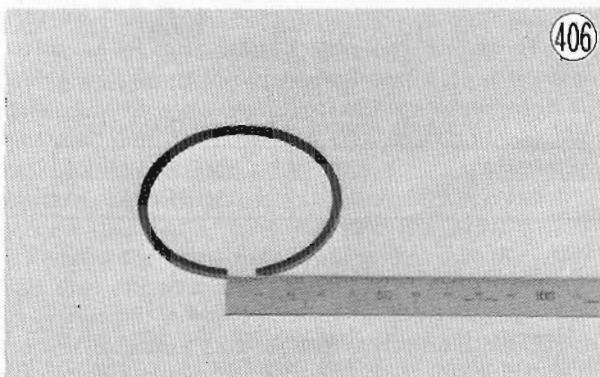

**Table 27 Ring End Gap**

Standard	Service Limit
0.2~0.4 mm	0.7 mm

**Piston ring tension**

Piston ring tension can be evaluated by measuring the gap between the ends of the ring with the ring free of any restraint. If the measured gap is less than the service limit, the ring is weak and must be replaced.



**Table 28 Ring Free Gap**

	Standard	Service Limit
Top ring	8 mm	5 mm
Second ring	10.5 mm	7.5 mm
Oil ring	9 mm	6 mm

**Piston, piston pin, con-rod wear**

Measure the diameter of the piston pin with a micrometer, and measure the inside diameter of both piston pin holes in the piston. If the piston pin diameter is less than the service limit at any point, replace the piston pin. If either piston pin hole diameter exceeds the service limit, replace the piston.

Measure the inside diameter of the con-rod small end. If the diameter exceeds the service limit, replace the con-rod.

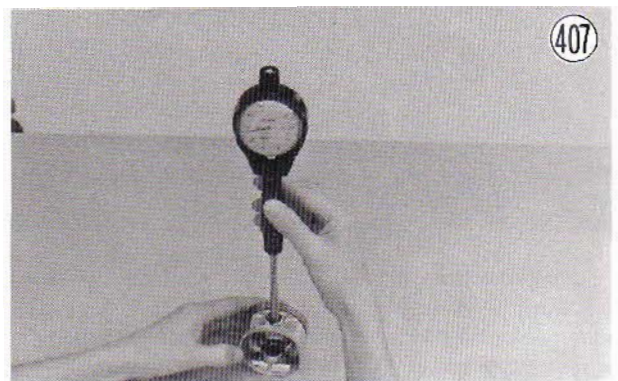

**Table 29 Piston Pin, Piston Pin Hole, Small End Dia.**

	Standard	Service Limit
Piston pin	14.994~15.000 mm	14.96 mm
Piston pin hole	15.004~15.011 mm	15.08 mm
Small end I.D.	15.003~15.014 mm	15.05 mm

**NOTE:** When a new piston or pin is used, also check that piston to pin clearance is 0.006 ~ 0.013 mm, and that pin to small end clearance is within 0.003 ~ 0.020 mm.

**To the Dealer:** When possible, match parts from stock so that a marked pin is assembled with an A piston, and an unmarked pin with an unmarked piston.

**CRANKSHAFT, CON-RODS**

The crankshaft is the part that changes the reciprocating motion of the pistons into rotating motion, which is transmitted to the rear wheel when the clutch is engaged. The con-rods are the parts that connect the pistons to the crankshaft. Crankshaft or con-rod trouble, such as worn crankshaft journals or a bent con-rod, will multiply the stress caused by the intermittent force on the pistons, and will result in not only rapid crankshaft bearing wear, but also noise, power loss, vibration, and a shortened engine life. A defective crankshaft or con-rod should always be detected at an early stage and then replaced immediately.

## 112 MAINTENANCE

The following explanation concerns the most common crankshaft and con-rod problems, giving the procedure for detecting damage and measuring wear and runout.

### Con-rod bend, twist

Set the crankshaft in a flywheel alignment jig or on V blocks on a surface plate. Select an arbor of the same diameter as the piston pin and of optional length, and insert it through the small end of the con-rod.

Using a height gauge or dial gauge, measure the difference in the height of the rod above the surface plate over a 100 mm length to determine the amount the con-rod is bent.

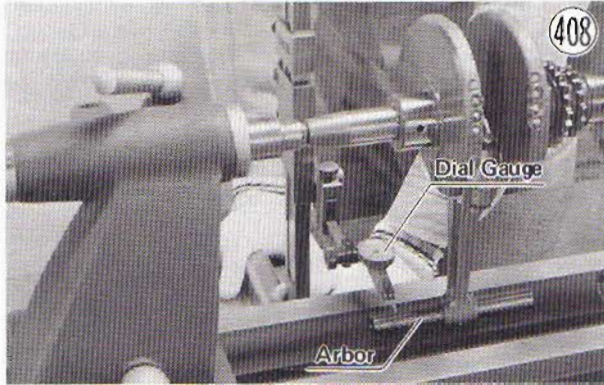

Using the arrangement shown in Fig. 409, measure the amount that the arbor varies from being parallel with the crankshaft over a 100 mm length of the arbor to determine the amount the con-rod is twisted.

If either of these measurements exceeds the service limit, replace the con-rod.

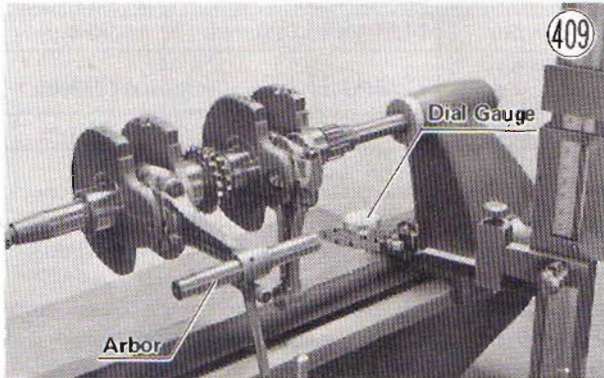

**Table 30 Con-rod Bend, Twist**

	Standard	Service Limit
Bend	under 0.05/100 mm	0.2 mm
Twist	under 0.15/100 mm	0.3 mm

### Con-rod bearing, crankshaft journal wear

Bearing wear is measured using a plastigauge (press gauge), which is inserted into the clearance to be measured. The plastigauge indicates the wear by the amount it is compressed and widened when the parts are assembled.

Remove the con-rods, cut strips of plastigauge to bearing width, and place a strip on the con-rod bearing half on each con-rod parallel to the crankshaft and so that the plastigauge will be compressed between the bearing and the crankshaft journal. Replace the con-rods, tightening the nuts with the specified torque (Pg. 175).

Remove the con-rods, and measure the plastigauge width to determine the bearing/journal wear. Replace the bearing halves if the wear has gone beyond the service limit.

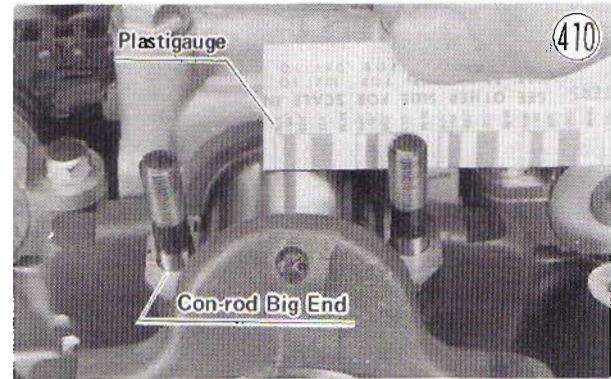

**Table 31 Con-rod Bearing/Journal Clearance**

Standard	Service Limit
0.041~0.071 mm	0.1 mm

Measure with a micrometer the diameter of the crankshaft journals on which the con-rods fit. If the diameter is less than the service limit or if either journal shows damage, replace the crankshaft.

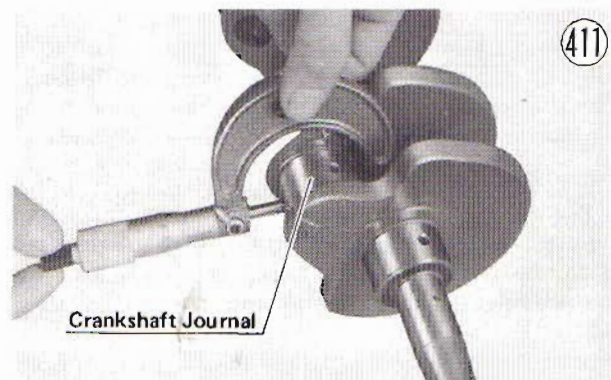

**Table 32 Crankshaft Journal (Con-rod) Diameter**

Standard	Service Limit
35.984~36.000 mm	35.94 mm

### Con-rod side clearance

Measure the side clearance of the con-rod with a thickness gauge as shown. Replace the crankshaft and

the con-rod if the clearance exceeds the service limit,



**Table 33 Con-rod Big End Side Clearance**

Standard	Service Limit
0.15~0.25 mm	0.45 mm

**Crankshaft runout**

Set the crankshaft in a flywheel alignment jig or on V blocks, and place a dial gauge to the points indicated. Turn the crankshaft slowly. The maximum difference in gauge readings is the crankshaft runout.

If the runout exceeds the service limit, replace the crankshaft.

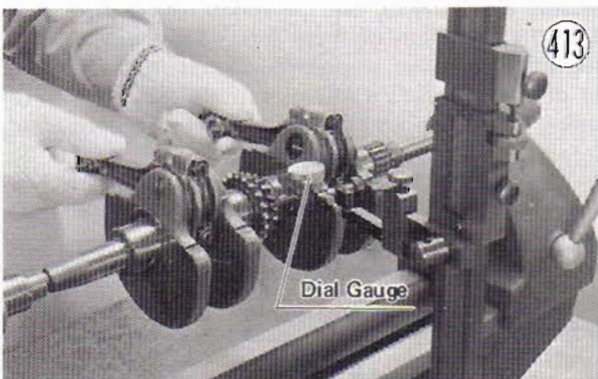

**Table 34 Crankshaft Runout**

Standard	Service Limit
under 0.02 mm	0.05 mm

**Crankshaft bearing/journal wear**

Remove the crankshaft, cut strips of plastigauge to bearing width, and place a strip on the half of each bearing parallel to the crankshaft and so that the plastigauge will be compressed between the bearing and the crankshaft journal. Install the crankshaft and the lower crankcase half in such a way that the crankshaft does not turn, tightening the bolts in the correct sequence with the specified amount of torque (Pg. 175).

Remove the crankshaft (making sure that the crankshaft does not turn at any time), and measure the plastigauge width to determine the bearing/journal wear. If either clearance exceeds the service limit, replace all four bearing halves.

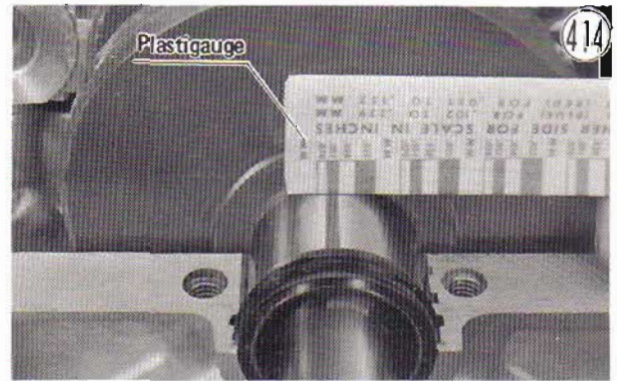

**Table 35 Crankshaft Bearing/Journal Clearance**

Standard	Service Limit
0.036~0.078 mm	0.11 mm

Measure the journals which wear on these bearings. If the micrometer reading is less than the service limit, replace the crankshaft.

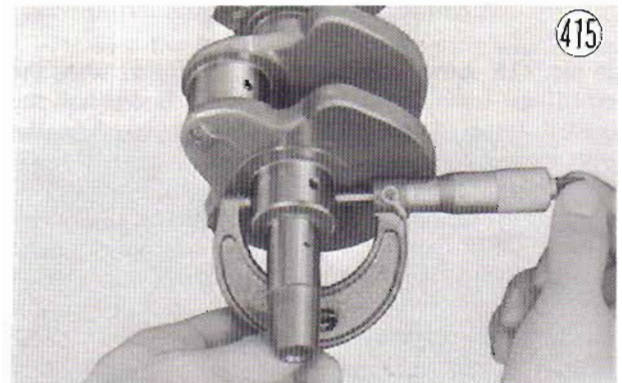

**Table 36 Crankshaft Journal (Not Con-rod) Diameter**

Standard	Service Limit
35.984~36.000 mm	35.94 mm

**Oil passage cleaning**

There is an oil passage running between the crankshaft journals on each side. Use compressed air to remove any foreign particles or residue that may have accumulated in these passages.

**BALANCER MECHANISM**

The balancer mechanism basically consists of two weights, which are chain-driven by the crankshaft. The following explanation covers how this mechanism reduce vibration.

The vibration on a 4-stroke, 2-cylinder engine is generally greater with larger engine displacement. This vibration is natural due to the mechanics of a reciprocating engine, but the proper addition of counterweights on the crankshaft can reduce this vibration. However, troublesome vibration remains unless some additional measure is taken.

Vibration Reduction with Crankshaft Counterweights only

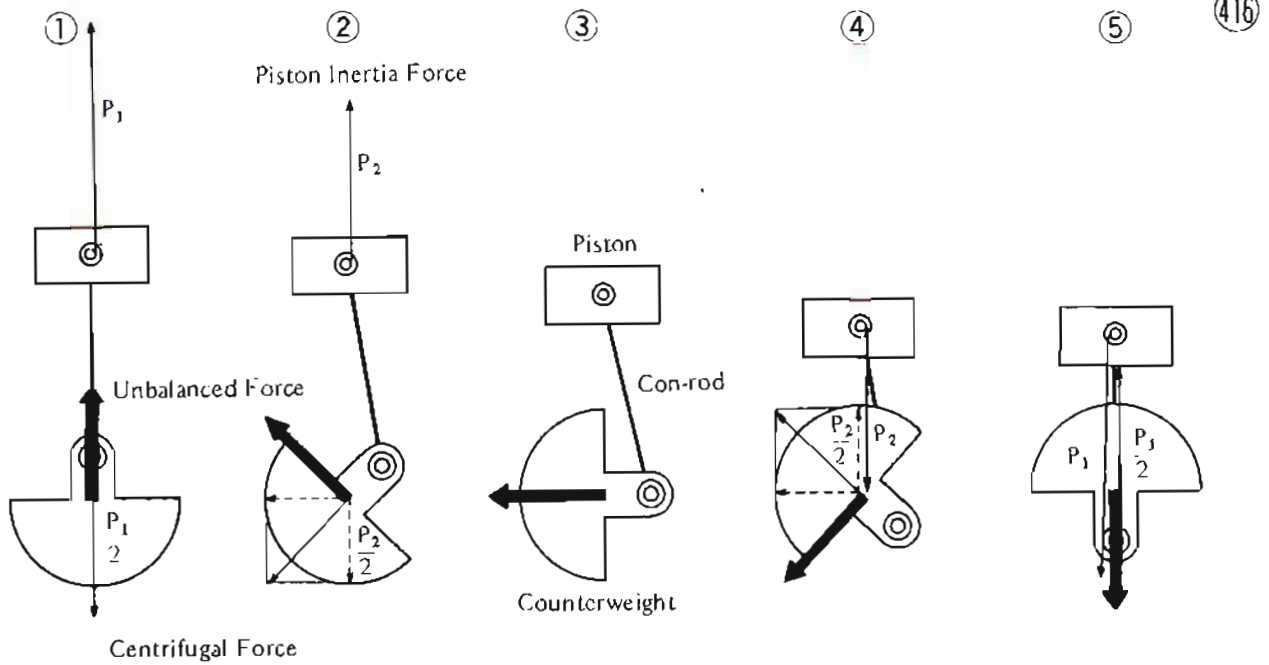

Fig. 416 shows the internal engine forces when the centrifugal force of the counterweights is one half the inertial force of the pistons. The arrows show the amount and direction of these forces.

As the crankshaft rotates clockwise, 1~5 in Fig. 416, one half of the inertial force of the pistons is negated by the vertical component of the centrifugal force of the counterweights. However, the horizontal component of the centrifugal force of the counterweights (brought about by having counterweights) is not negated by anything. The thick arrows indicate the resulting unbalanced force, which is the main cause of engine vibration.

The balancer mechanism includes two balancing weights having one half the centrifugal force of the counterweights. A balancing weight is installed at an equal distance on both sides of the crankshaft for rotation by a chain in such a way that the weights rotate in the direction opposite to the crankshaft counterweights.

Fig. 417 shows how this mechanism works at one crankshaft position. The centrifugal force of the balancer weights exert a pull on the engine to the lower right as the arrows in the figure show. On the other hand,

Balancer Mechanism

417

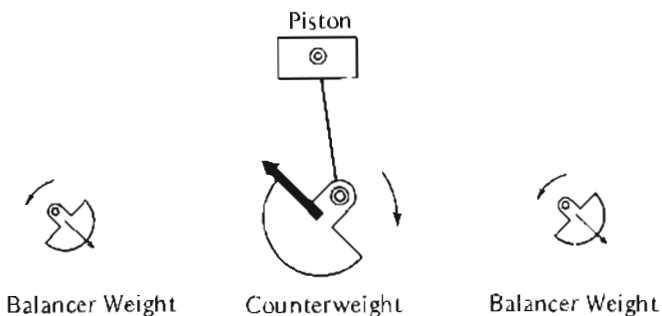

the crankshaft counterweights are exerting a pull on the engine to the upper left. The centrifugal force due to the two balancer weights equals the unbalanced force which results when only the crankshaft counterweights are installed, but the forces cancel each other since the directions of these forces are opposite. With the forces cancelled, engine vibration is greatly reduced. At other crankshaft positions as well, these two forces are equal and opposing such that they cancel each other, keeping the system always in balance.

The balancer weights, turning at the same rpm as the crankshaft, are chain-driven by a sprocket which is part of the crankshaft. The balancer chain is an endless-type for maximum durability and wears very slowly due to its ample lubrication. The chain drives the weights through a sprocket on each side of the mechanism. Each sprocket has four springs, which are wedged between the sprocket and the weights to protect the sprocket and chain from the severe torque during the combustion stroke. In the center of each spring is a pin, which prevents damage to the spring from excessive compression.

If balancer mechanism trouble develops, such as excessive shaft or chain wear, not only are the bearings and crankcase parts affected but the resulting power loss and engine vibration may adversely affect performance and overall engine life.

Balancer shaft, holder wear

Measure with a micrometer the diameter of each shaft where it wears on the holders, and measure with a cylinder gauge the inside diameter of each holder. Replace a shaft which has worn down on either side to less than the service limit. Replace any holder for which

the inside diameter exceeds the service limit.

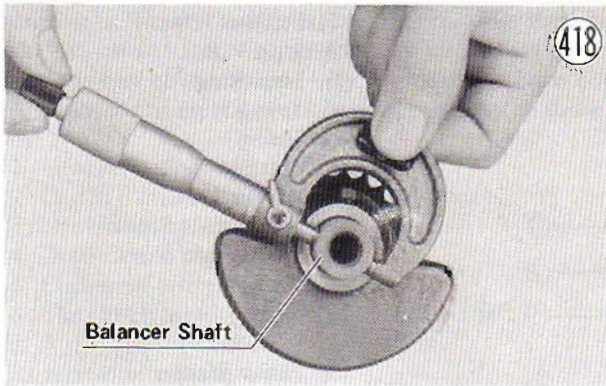

Table 37 Balancer Shaft, Holder Diameter

	Standard	Service Limit
Balancer Shaft	19.967~19.980 mm	19.93 mm
Holder I.D.	20.007~20.028 mm	20.08 mm

**Chain wear**

Remove the chain, hold it taut with a force of about 5 kg in some manner such as the one shown in Fig. 419, and measure a 20-link length. If the chain has lengthened beyond the service limit, replace it for a new one.

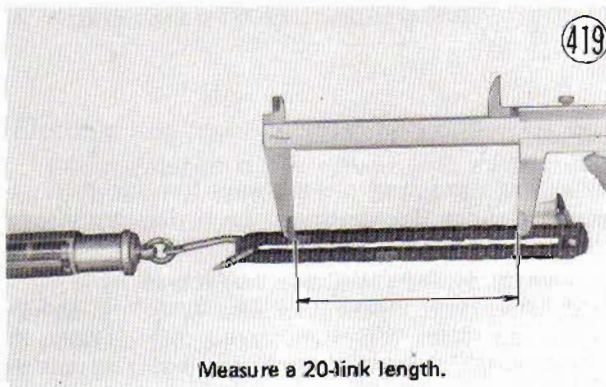

Table 38 Balancer Chain Length

Standard	Service Limit
160 mm	162.4 mm

When replacing a chain for a new one, inspect all the sprockets. If either of the balancer mechanism sprockets is damaged or overly worn, replace it. If the crankshaft sprocket is damaged or overly worn, replace the crankshaft.

**NOTE:** If the crankshaft is replaced, the crankshaft journal/con-rod clearance should be checked (Pg. 112).

**Chain guide wear**

Visually inspect the rubber part of each chain guide. If it is worn down or damaged, replace the guide.

Measure the thickness with a ruler. If the wear has exceeded the service limit, replace the guide.

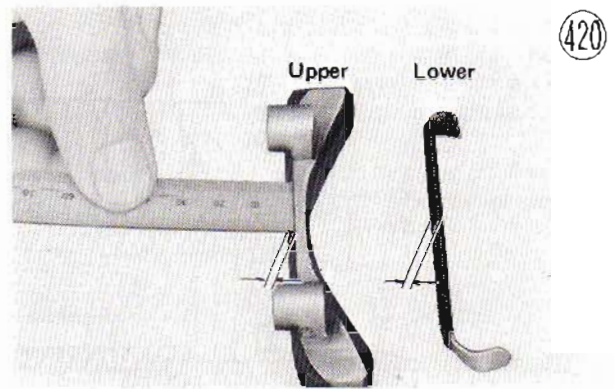

Table 39 Chain Guide Thickness

	Standard	Service Limit
Upper	2 mm	1 mm
Lower	2.5 mm	1 mm

**NOTE:** The designations upper and lower refer to the relative position of the chain guides when the engine is right side up.

**Spring free length**

Measure the free length of each spring with vernier calipers. Replace any spring which is shorter than the service limit.

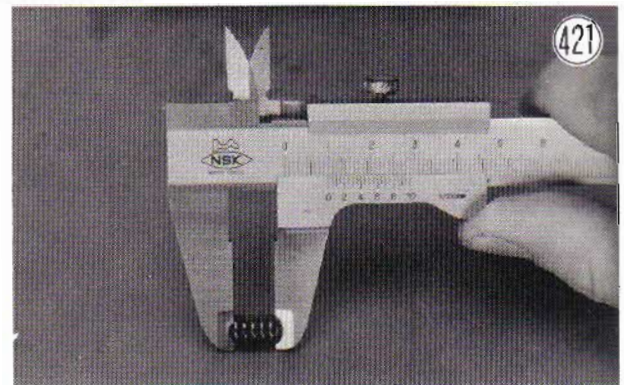

Table 40 Spring Free Length

Standard	Service Limit
9.8~10.4 mm	9 mm

**CLUTCH**

Fig. 422 shows the construction of the clutch, which is a wet, multi-plate type with 6 friction plates ③, 5 steel plates ④, and 6 steel rings ⑤. The friction plates are made of cork, used for its high coefficient of friction, bonded on a steel core, which provides durability and warp resistance. The clutch housing ② has a reduction sprocket on one side and contains springs to absorb shock from the drive train.

The clutch release mechanism is shown in Fig. 423. The clutch release outer worm gear is made of nylon and the inner one of steel. Assembled into the center of the release inner gear is the clutch adjusting screw, which pushes on the push rod and steel ball inside the drive shaft to release the clutch.

Clutch

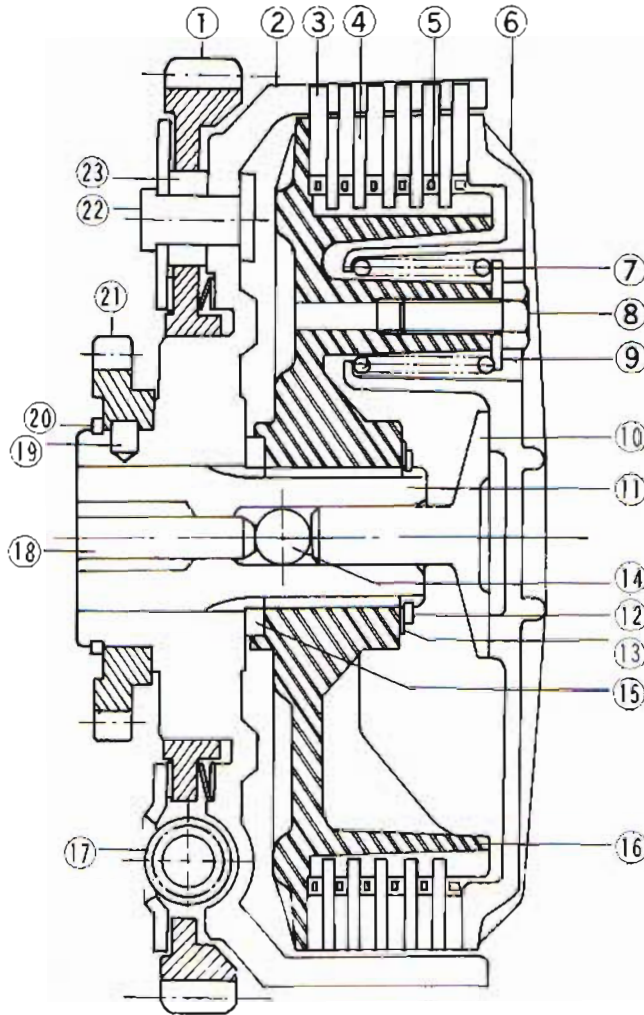

1. Clutch Housing Sprocket
2. Clutch Housing
3. Friction Plate
4. Steel Plate
5. Steel Ring
6. Spring Plate
7. Spring
8. Bolt
9. Washer
10. Spring Plate Pusher
11. Drive Shaft
12. Circlip
13. Shim(s)
14. Steel Ball
15. Thrust Washer
16. Clutch Hub
17. Shock Damper Spring
18. Push Rod
19. Pin
20. Circlip
21. Oil Pump Drive Gear
22. Rivet
23. Collar

422

Clutch Release Mechanism

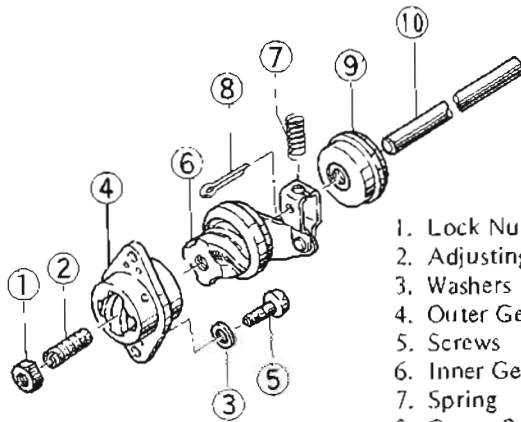

1. Lock Nut
2. Adjusting Screw
3. Washers
4. Outer Gear
5. Screws
6. Inner Gear
7. Spring
8. Cotter Pin
9. Oil Seal
10. Push Rod

423

The friction plates are connected to the clutch housing by tangs on the outer circumference of each plate, and, since the clutch housing is chain driven directly by a sprocket on the crankshaft, these plates are always turning any time the engine is running. The steel plates have a toothed inner circumference, which meshes with the splines in the clutch hub on the drive shaft so that the

drive shaft and steel plates always turn together. To improve clutch disengagement, steel rings are inserted between the friction and steel plates.

One end of each clutch spring forces against its washer and bolt, which threads into the clutch hub, and the other end forces against the spring plate. When the clutch is left engaged, the springs pressing against the spring plate force the spring plate, friction and steel plates, steel rings, and clutch hub tightly together so that the friction plates will drive the steel plates by virtue of their mutual friction and thereby transmit the power to the transmission drive shaft.

When the clutch lever is pulled to release (disengage) the clutch, the clutch cable turns the clutch release inner worm gear in towards the clutch. The clutch adjusting screw, assembled inside the clutch release inner worm gear, then pushes the push rod, which through the steel ball and spring plate pusher pushes the spring plate. Since the spring plate moves the same distance that the inner worm gear moves and the clutch hub remains stationary, the springs are compressed and the spring pressure is taken off the clutch plates. Because the plates are no longer pressed together, the power transmission from the crankshaft to the transmission drive shaft is interrupted. However, as the clutch lever is released, the clutch springs return the spring plate and once again force the spring plate, plate assembly,

and clutch hub tightly together.

A clutch that does not properly disengage will cause shifting difficulty and possible transmission damage. On the other hand, a slipping clutch will reduce power transmission efficiency and may overheat and burn out. A clutch that does not properly disengage may be caused by:

1. Excessive clutch lever play.
2. Clutch plates that are warped or too rough.
3. Uneven clutch spring tension.
4. Deteriorated engine oil.
5. Engine oil of too high a viscosity.
6. The clutch housing frozen on the drive shaft.
7. A defective clutch release mechanism.
8. Broken or missing steel rings.
9. An unevenly worn clutch hub or housing.

A slipping clutch may be caused by:

1. No clutch lever play.
2. Worn friction plates.
3. Weak clutch springs.
4. The clutch cable not sliding smoothly.
5. A defective clutch release mechanism.
6. An unevenly worn clutch hub or housing.

Clutch noise may be caused by:

1. Excessively worn primary chain and sprockets.
2. Damaged sprocket teeth.
3. Too much clearance between the friction plate tangs and the clutch housing.
4. Weak or damaged shock absorber spring(s).

**Clutch spring tension**

Clutch springs that have become weak will not return to their original length when disassembled from the clutch. Their condition can thereby be determined by measuring the free length with vernier calipers.

If any spring is shorter than the service limit, replace all the springs as a matched set to ensure even tension on the clutch plates.

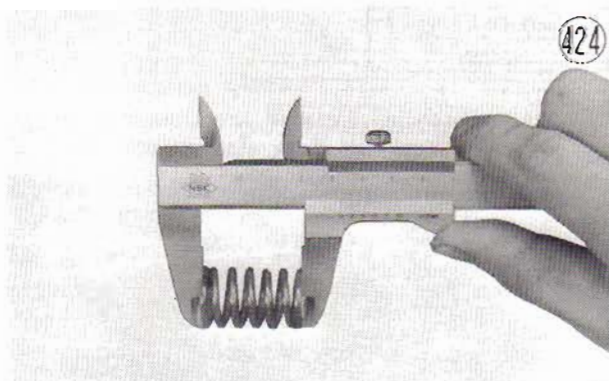

**Table 41 Clutch Spring Free Length**

Standard	Service Limit
33,8 mm	32,3 mm

**Friction plate wear, damage**

Visually inspect the friction plates to see whether or not they show any signs of heat seizure or have become rough or unevenly worn. Measure the thickness of the plates with vernier calipers.

If any plates show signs of damage, or if they have worn past the service limit, replace them for new ones.

**Friction Plate Measurement**

425



**Table 42 Friction Plate Thickness**

Standard	Service Limit
2,9~3,1 mm	2,5 mm

**Clutch plate warp**

Place each friction plate and each steel plate on a surface plate, and measure the gap between each clutch plate and the surface plate. This gap is the amount of clutch plate warp.

Replace any plates warped over the service limit.



**Table 43 Clutch Plate Warp**

	Standard	Service Limit
Friction Plate	under 0,15 mm	0,30 mm
Steel Plate	under 0,20 mm	0,40 mm

**Steel ring damage**

Visually inspect the steel rings. Replace any which are bent, broken, or otherwise damaged.

**Friction plate/clutch housing clearance**

Measure the clearance between the tangs on the friction plates and the fingers of the clutch housing. If this clearance is excessive, the clutch will be noisy.

If the clearance exceeds the service limit, replace the friction plates. Also, replace the clutch housing if it is unevenly or badly worn where the friction plates wear against it.

Friction Plate/Clutch Housing Clearance

427

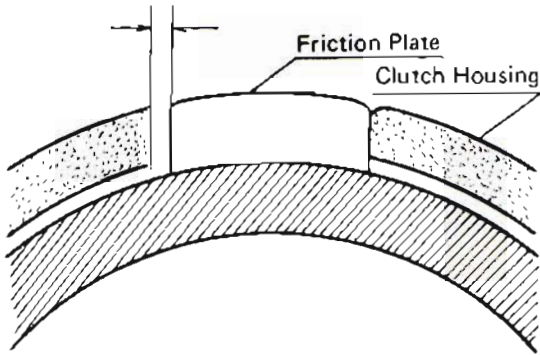
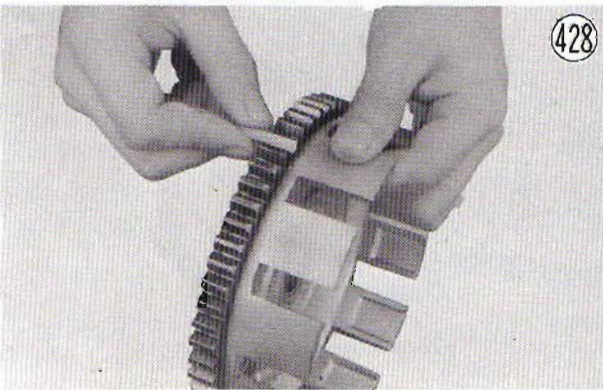

Table 44 Friction Plate/Clutch Housing Clearance

Standard	Service Limit
0.15~0.40 mm	0.60 mm

Clutch housing sprocket damage

Inspect the teeth on the clutch sprocket. Any light damage can be corrected with an oilstone, but the clutch housing must be replaced if the teeth are badly damaged. Damaged teeth on the clutch housing sprocket indicate that the primary chain, by which it is driven, may also be damaged. At the same time that the clutch housing sprocket is repaired or replaced, the primary chain should be inspected, and then replaced if necessary.



Clutch housing/drive shaft wear

Measure the diameter of the drive shaft with a micrometer, and measure the inside diameter of the clutch housing. Find the difference between the two readings to determine the clearance. Replace the clutch housing if the clearance exceeds the service limit.

Table 45 Clutch Housing/Drive Shaft Wear

Standard	Service Limit
0.020~0.062 mm	0.162 mm

Clutch hub damage

Inspect where the teeth on the steel plates wear against the splines of the clutch hub. If there are notches worn into the splines, replace the clutch hub.

Clutch release gear wear

Fit the outer and inner clutch release worm gears together, and push them back and forth in the direction of the shaft without turning them. If there is excessive play, replace them both. Also, replace them if either one is visibly damaged.

Lubrication

Lubricate the clutch release worm gears with grease.

PRIMARY CHAIN

The power transmission from the crankshaft to the drive shaft is chain-drive, utilizing a Hy-Vo (high velocity) chain. This Hy-Vo chain is a locker-joint type with a pin and locker construction. Some of the special features of the Hy-Vo chain are its capacity to transmit much power at high speed, its lack of susceptibility to heat seizure due to a construction which employs rolling rather than sliding friction, quiet operation even at high rpm, and low power loss.

Wear

A primary chain which has worn such that it is 1.4% or more longer than when new is no longer safe for use, and should be replaced. Inspect the wear by measuring the chain slack, and replace the chain if it has worn past the service limit. The replacement chain must be the Tsubakimoto Hy-Vo 3/8P-5/8W, 74-link chain.

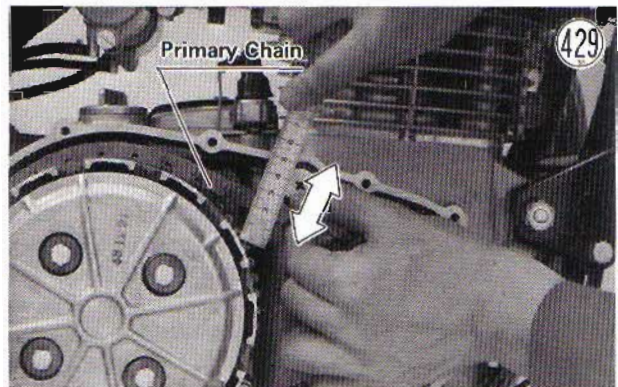
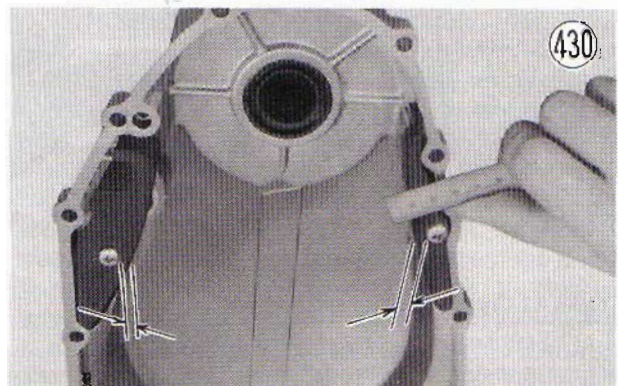

Table 46 Primary Chain Wear

Service Limit
20 mm

When a new chain is installed, check the chain guides, and replace for new ones if necessary.



**Table 47 Primary Chain Guide Thickness**

Standard	Service Limit
7.5 mm	3.5 mm

**NOTE:** When installing new chain guides, apply a non-permanent locking agent to the chain guide screws, and replace the chain guides.

**TRANSMISSION**

The transmission is a 5-speed, constant mesh, return shift type. Its cross section is shown in Fig. 434, and the external shift mechanism is shown in Fig. 435. For simplicity, the drive shaft gears in the following explanation are referred to as "D" (e.g., D1=drive shaft 1st gear) and the output shaft gears as "O".

Gears D3, O4, and O5 are all splined to and thus rotate along with their shaft. During gear changes these gears are moved sidewise on their shaft by the 3 shift forks, one for each gear. Gears D4, D5, O1, O2, and O3 rotate free of shaft rotation, but cannot move sidewise. Gears D1 and D2 are part of shaft rotation and are unable to move sidewise.

When the shift pedal 23 is raised or lowered, the shift shaft 22 turns, a pawl 25 on the external shift mechanism arm 26 catches on one of the shift drum pins 10, and the shift drum 7 turns. As the shift drum turns, the shift fork guide pins 27 (3), each riding in a groove in the shift drum, shift the position of one or another of the shift forks 6 19 20 in accordance with the winding of the grooves. The shift fork ears then determine the position of gears D3 1, O4 17, and/or O5 18. Refer to Figs. 431 to 438 for the gear train for neutral and each of the 5 gears.

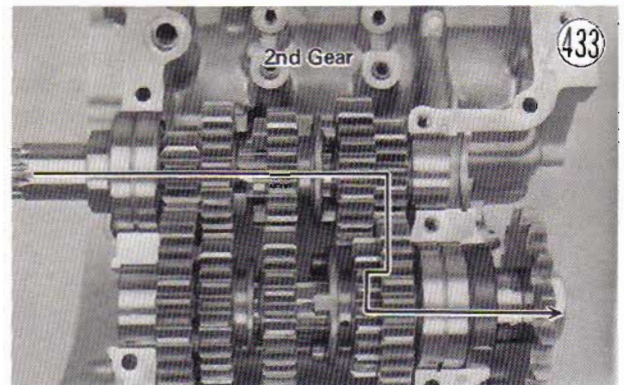
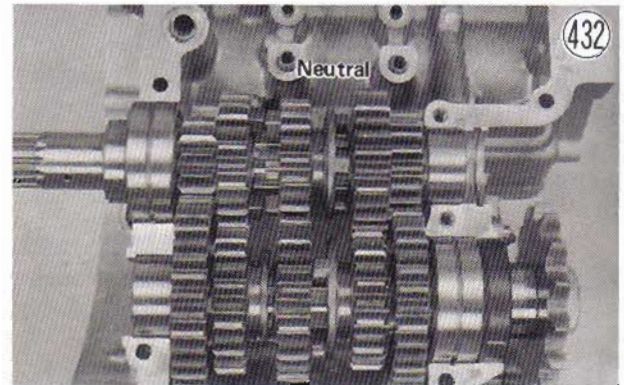
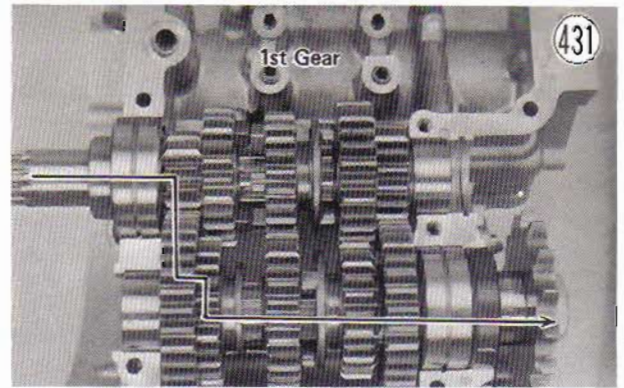

**Transmission Cross Section**

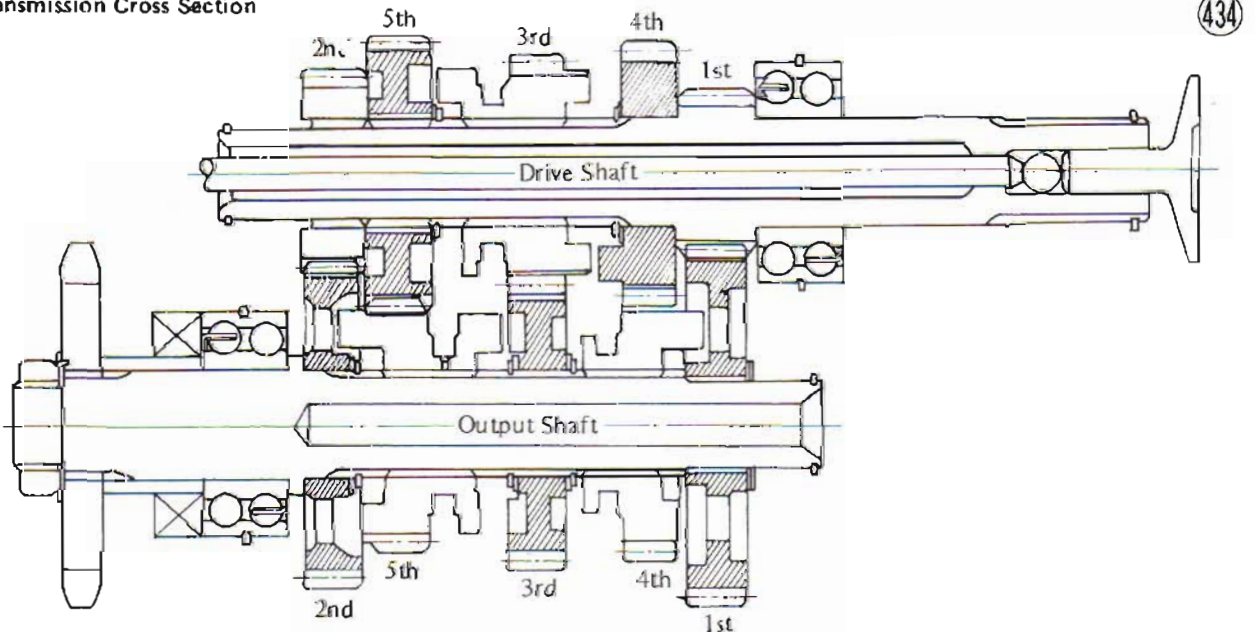

# 120 MAINTENANCE

## Shift Mechanism

1. Drive 3rd Gear
2. Shift Drum Positioning Bolt
3. Pin
4. Spring
5. Operating Plate
6. Shift Fork
7. Shift Drum
8. Shift Drum Stopper
9. Screw



10. Shift Drum Pin
11. Shift Drum Pin Plate
12. Lock Washer
13. Screw
14. Spring
15. Return Spring Pin
16. Return Spring
17. Output 4th Gear
18. Output 5th Gear
19. Shift Fork
20. Shift Fork
21. Shift Rod
22. Shift Shaft
23. Shift Pedal
24. Shift Pedal Bolt

25. Pawl
26. Shift Mechanism Arm
27. Guide Pin

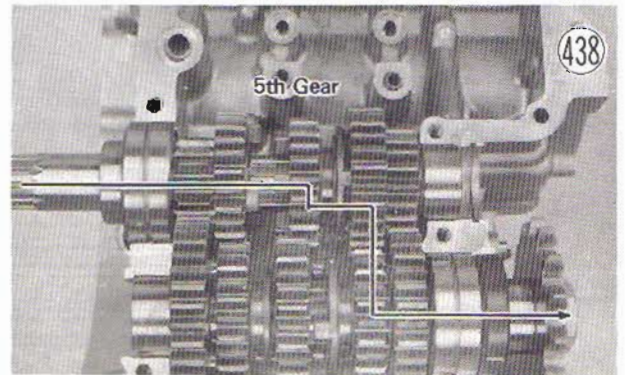
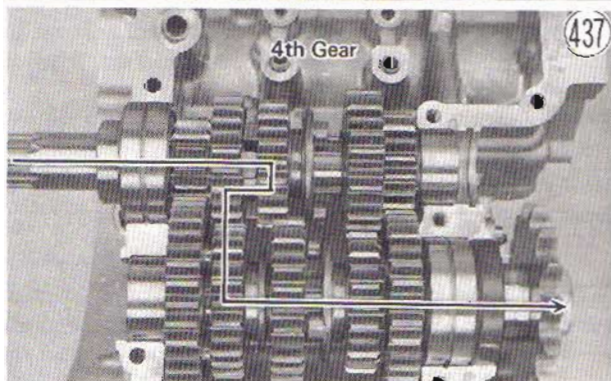
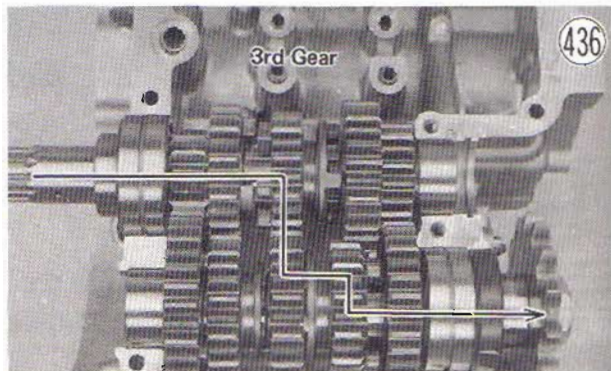
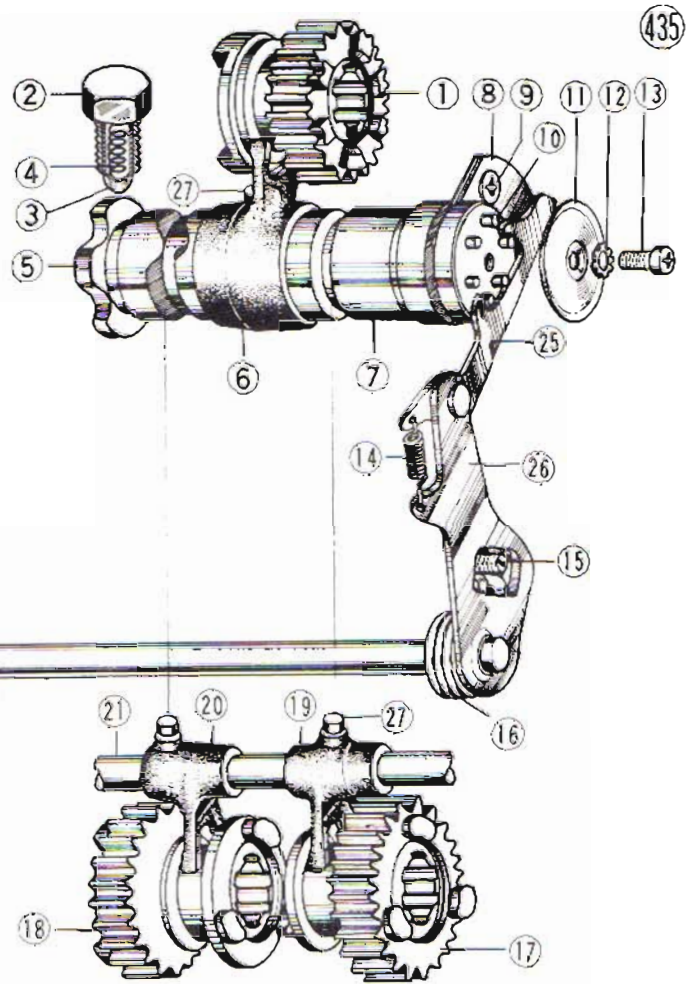

A spring (16) is fitted on the external shift mechanism to keep the shift arm pressed against the shift drum pins to ensure proper pawl and pin contact. When the shift pedal is released after shifting, the return spring (16), returns the pawl and shift pedal back to their original position. So that the transmission will remain where it was shifted, another spring, the shift drum positioning pin spring (4), pushes the shift drum positioning pin (3) into one of six positions on the shift drum operating plate (5). Five of these positions are equally spaced and correspond to the 5 gears. The other position is halfway

between the position for 1st and 2nd gears and corresponds to the half-stroke shift pedal movement from 1st or 2nd gear required to shift into neutral.

The return spring pin (13) on the side of the crankcase passes through a cutout on the shift mechanism. Each time that the shift pedal is operated, the pin limits the shift mechanism's range of movement, stopping the shift mechanism after the pawl on the shift mechanism arm has rotated the shift drum the proper amount for gear change. The return spring pin thus prevents the drum from being rotated too far.

A neutral indicator light is provided so that the rider can readily determine whether or not the transmission is in neutral. The neutral indicator switch, installed in the crankcase near the starter motor, consists of a spring loaded pin which comes into contact with a nub on the side of the shift drum whenever the transmission is in neutral. When the shift drum has shifted the transmission into neutral, the neutral indicator switch pin touching this nub completes the neutral indicator light circuit, which turns the neutral indicator light on.

Transmission or external shift mechanism damage, causing the transmission to misshift, overshift, and/or jump out of gear, brings about more damage to the transmission and also overrev damage to the engine itself. An improperly functioning transmission or external shift mechanism may be caused by the following:

1. Loose return spring pin
2. Broken or weakened return spring or shift drum positioning pin spring
3. Broken or weakened shift pawl spring
4. Damaged shift mechanism arm
5. Loose shift drum stopper
6. Bent or worn shift fork(s)
7. Worn shift fork groove on gear D3, O4, and/or O5
8. Worn shift fork guide pin(s)
9. Worn shift drum groove(s)
10. Worn or damaged gear dogs, gear dog holes, and/or gear dog recesses
11. Improperly functioning clutch or clutch release
12. Improper assembly or missing parts

Transmission noise results from worn or damaged shafts, gear hubs or teeth, bearings, etc.

**External shift mechanism inspection**

Inspect the shift pawl spring, shift pawls, and return spring. Replace any broken or otherwise damaged parts.

Measure the free length of the shift pawl spring. If it exceeds the service limit, replace it for a new one.

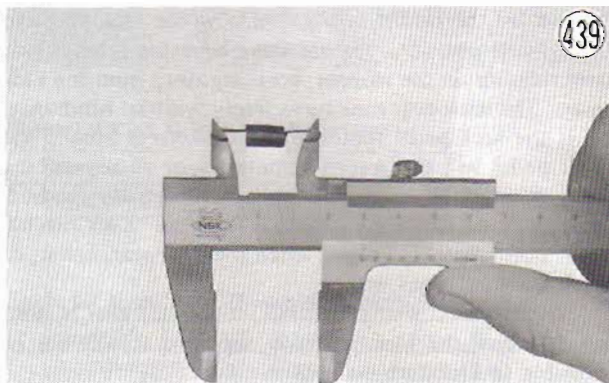

**Table 48 Shift Pawl Spring Free Length**

Standard	Service Limit
29.4 mm	31 mm

Check to see if the return spring pin is loose or not. If it is loose, remove it and apply a locking agent to the threads. Then screw it back in tightening its lock nut.

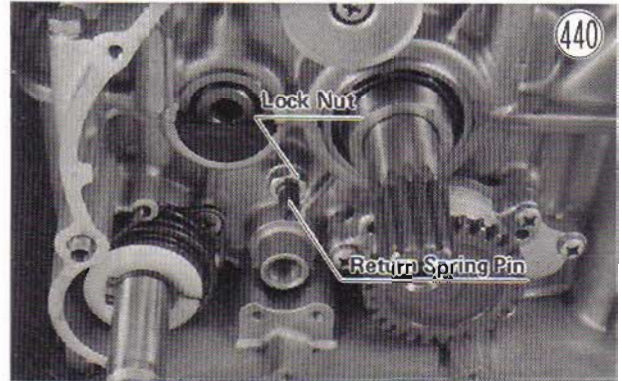

**Gear backlash**

Split the crankcase. Leaving the transmission in place, measure the backlash between gears O1 and D1, O2 and D2, O3 and D3, O4 and D4, and O5 and D5. To measure the backlash, set a dial gauge against the teeth of one gear, and move the gear back and forth while holding the other gear steady. The difference between the highest and the lowest gauge reading is the amount of backlash. Replace both gears wherever the amount of backlash exceeds the service limit.

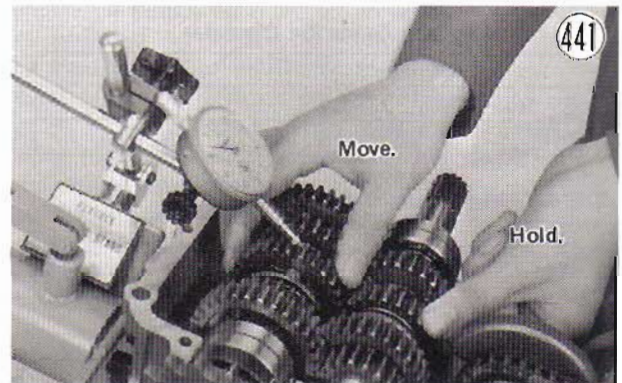

**Table 49 Gear Backlash**

Standard	Service Limit
0.06~0.23 mm	0.3 mm

**Shift fork bending**

Visually inspect the shift forks, and replace any fork that is bent. A bent fork could cause difficulty in shifting or allow the transmission when under power to jump out of gear.

**Shift fork/gear groove wear**

Measure the thickness of the ears of each shift fork, and measure the width of the shift fork groove on gears D3, O4, and O5. If the thickness of a shift fork ear is under the service limit, the shift fork must be replaced. If a gear shift fork groove is worn over the service limit, the gear must be replaced.

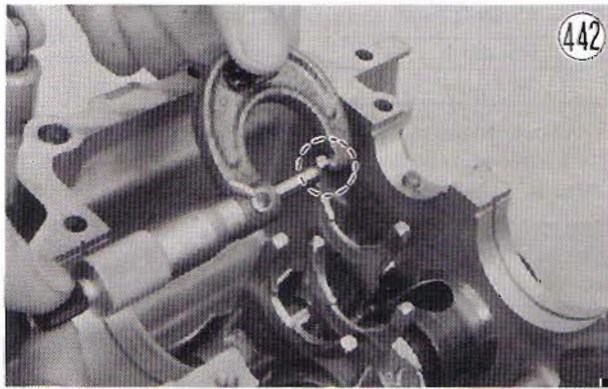
**Table 50 Shift Fork Thickness**

Standard	Service Limit
4.9~5.0 mm	4.7 mm

**Table 51 Gear Shift Fork Groove Width**

Standard	Service Limit
5.05~5.15 mm	5.25 mm

**Shift fork guide pin/shift drum groove wear**

Measure the diameter of each shift fork guide pin, and measure the width of each shift drum groove. Replace any shift fork on which the guide pin has worn past the service limit. If a shift drum groove is worn past the service limit, replace the shift drum.

**Table 52 Shift Fork Guide Pin Diameter**

	Standard	Service Limit
4th, 5th	7.9~8.0 mm	7.85 mm
3rd	7.985~8.000 mm	7.93 mm

**Table 53 Shift Drum Groove Width**

Standard	Service Limit
8.05~8.20 mm	8.23 mm

**Shift fork guide pin/shift drum groove clearance**

Measure the clearance between each shift fork guide pin and shift drum groove with a thickness gauge. Replace any shift fork with which the clearance exceeds the service limit.

**Table 54 Shift Fork Guide Pin/Shift Drum Groove Clearance**

	Standard	Service Limit
4th, 5th	0.05~0.30 mm	0.38 mm
3rd	0.05~0.22 mm	0.30 mm

**Gear dog, gear dog hole, gear dog recess damage**

Visually inspect the gear dogs, gear dog holes, and gear dog recesses. Replace any gears that have damaged or unevenly or excessively worn dogs, dog holes, or dog recesses.

**Gear/shaft wear**

Measure the diameter of each shaft and bush with a micrometer, and measure the inside diameter of each gear listed below. Find the difference between the two readings to figure clearance, and replace any gear where clearance exceeds the service limit.

**Table 55 Gear/Shaft, Gear/Bush Clearance**

	Standard	Service Limit
D4, D5, O2, O3	0.020~0.062 mm	0.162 mm
O1	0.027~0.061 mm	0.161 mm

**Ball bearing wear, damage**

Since the ball bearings are made to extremely close tolerances, the wear must be judged by feel rather than by measurement.

Clean each bearing in a high flash point solvent of some kind, dry it (do not spin it while it is dry), and oil it. Spin it by hand to check its condition. If it is noisy, does not spin smoothly, or has any rough spots, replace it.

**KICKSTARTER**

Kickstarter construction is shown in Fig. 443. The kick gear is connected to the primary sprocket on the crankshaft through the output shaft 1st gear, drive shaft 1st gear, clutch housing sprocket, and primary chain.

The kick gear (8), constructed with a ratchet on one side, is always meshed with the output shaft 1st gear and turns freely anytime the output shaft is turning. The ratchet gear (9), mounted on the splined portion of the kick shaft (3), always turns with the kick shaft and can be moved sidewise on the shaft. A spring (10) presses on the ratchet gear in the direction of the kick gear, but, when the kick pedal (1) is not being operated, an arm on the ratchet gear is caught on the stopper (2), which prevents the ratchet gear from meshing with the ratchet on the kick gear.

When the kick pedal is operated, the ratchet gear arm is freed from the stopper and the ratchet gear then meshes with the kick gear ratchet rotating the kick gear. The gear train of the kickstarter system then cranks the engine. As the engine starts, the primary sprocket through the gear train turns the kick gear. But, since the kick gear rotates in the direction of arrow "A" as shown in Fig. 443, the kick gear ratchet doesn't catch on the ratchet gear.

When the kick pedal is released, the kick shaft is turned by the return spring returning the kick pedal to its original position. At the same time the ratchet gear arm rides up on the stopper, breaking away from the kick gear. The kick gear now turns freely without hindrance.

If the kick pedal return spring weakens or breaks, the kick pedal will not return completely or at all, and the kick gear and ratchet gear will stay partially meshed, making noise while the engine is running. Kick mechanism noise may also result when the kick gear, collar, or kick shaft becomes worn.

If the ratchet gear of ratchet on the kick gear is worn or damaged, the kick gear will slip, and it will not be possible to kickstart the engine.

Kickstarter

443

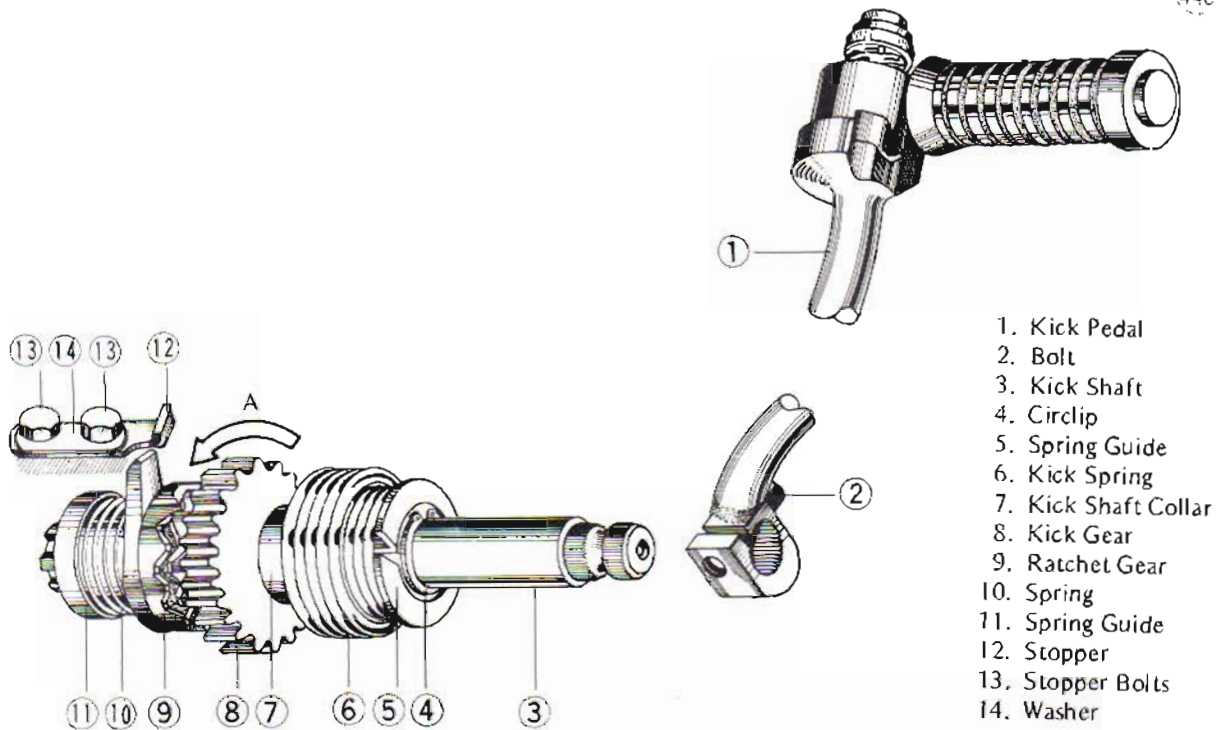

1. Kick Pedal
2. Bolt
3. Kick Shaft
4. Circlip
5. Spring Guide
6. Kick Spring
7. Kick Shaft Collar
8. Kick Gear
9. Ratchet Gear
10. Spring
11. Spring Guide
12. Stopper
13. Stopper Bolts
14. Washer

*Kick gear, shaft wear*

Measure the inside diameter of the kick gear, and replace the gear if the diameter is over the service limit. Visually inspect the ratchet portion of the kick gear. If there is any kind of damage, replace the kick gear.

Measure the kick shaft diameter at the kick gear, and replace it if it is under the service limit.

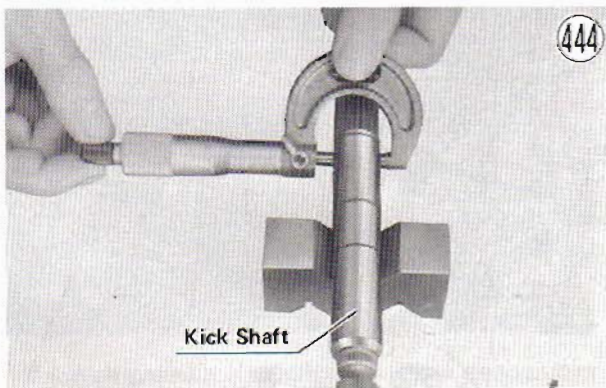

Table 56 Kick Gear Inside Diameter

Standard	Service Limit
20,000~20,021 mm	20,07 mm

Table 57 Kick Shaft Diameter at Kick Gear

Standard	Service Limit
19,959~20,000 mm	19,93 mm

ENGINE LUBRICATION

The engine lubrication system includes the oil screen, engine oil pump, oil filter, oil pressure relief valve, and oil passages. An oil pressure indicator switch is provided to warn in case of insufficient oil pressure, and an oil breather keeps crankcase pressure variations to a minimum. The discussion here concerns how these parts work together, how the oil reaches the various parts of the engine, and how to check the oil pressure. Details on the engine oil pump, oil filter, and oil breather are given in the sections (Pgs. 126~127) following engine lubrication.

Since the engine lubrication system is the wet sump type, there is always a supply of oil at the bottom of the engine in the crankcase. The oil is drawn through the wire screen into the oil pump as the pump rotors rotate, driven by a gear attached to the rear of the clutch housing. The screen removes any metal particles and other foreign matter of any size which could otherwise damage the oil pump. From the pump the oil passes through the oil filter element for filtration. If the element is badly clogged slowing the flow of oil through it, oil bypasses the element through a bypass valve in the filter. After passing through the filter the oil passes through the crankcase main oil passage to where it branches in four different lubrication routes.

One of these routes is to the crankshaft bearings, from which the oil then goes to the crankshaft journals at the con-rod big ends and to the starter motor crankshaft sprocket. Oil by the force of crankshaft rotation reaches the cylinder walls, pistons, and piston pins. The oil then drops and collects at the bottom of the crankcase to be used again.

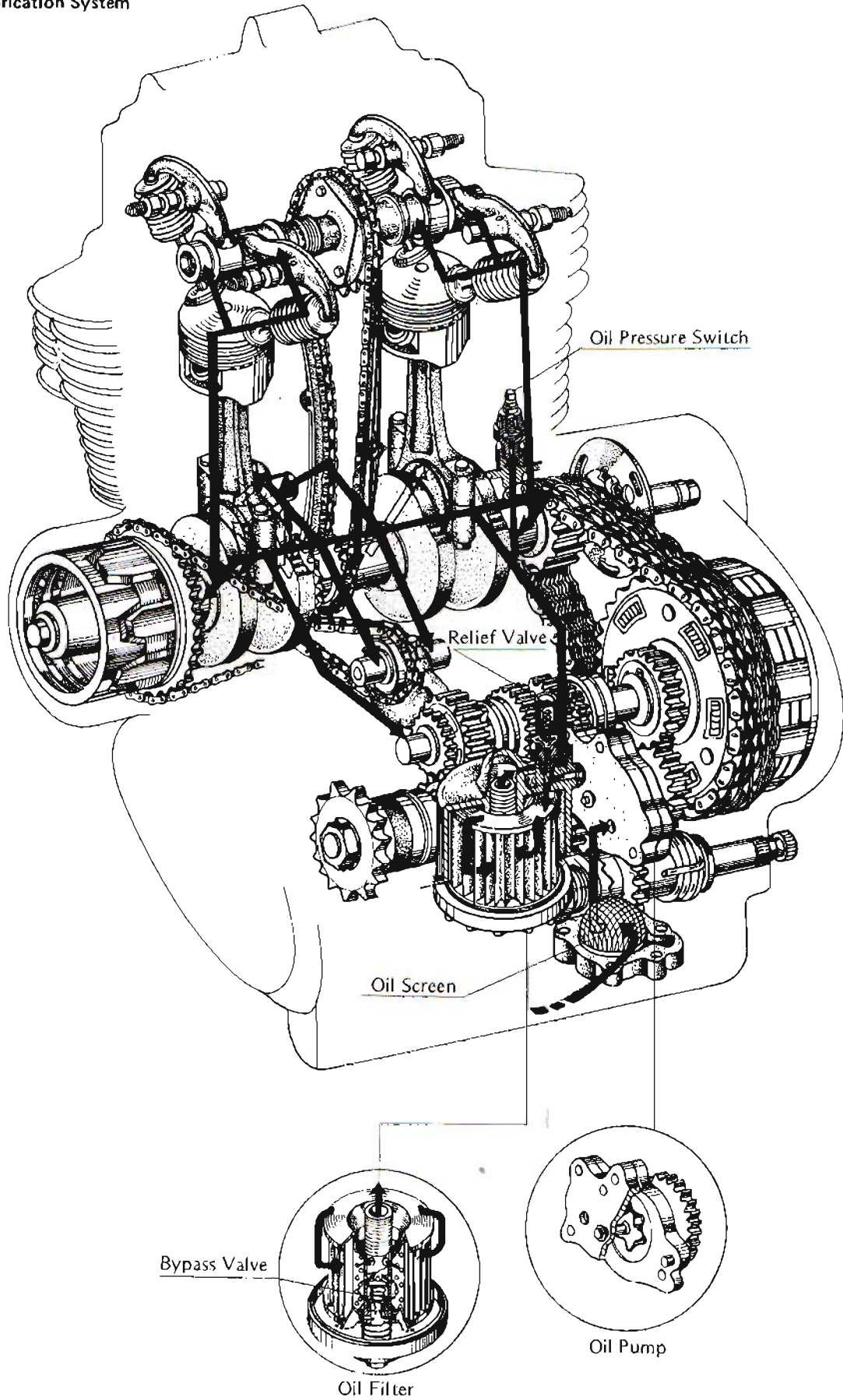

Another route leads to the balancer mechanism shafts. After shaft lubrication the oil drops and collects at the bottom of the crankcase for recirculation.

A third route for the oil is through the oil passage at each end of the cylinder block up to the top of the cylinder head. The oil reaches the camshaft journals, camshaft cams, and valve guides. The oil then drops through the camshaft chain opening back to the bottom of the crankcase.

A fourth route for the oil is to the transmission through a passage existing at one of the drive shaft bearings. Following lubrication the oil drops back down to the bottom of the crankcase.

Both the oil pressure indicator switch and the oil pressure relief valve are important for maintaining a constant oil pressure. The oil pressure indicator switch, mounted on the upper part of the crankcase, checks on the oil pressure of the oil in the main oil passage and lights the oil pressure warning light if the pressure falls below a safe value. If the oil pressure is insufficient, the oil pump is worn or malfunctioning or there is insufficient oil to the pump. On the other hand, if the oil pressure becomes excessive, such as when the engine is started (especially in cold weather), the relief valve reduces the oil pressure. The relief valve opens whenever a pressure of 5.2 kg/cm<sup>2</sup> (74 psi) presses on the valve spring.

**Oil pressure measurement**

Remove the oil pressure indicator switch from the crankcase, and connect the oil pressure gauge adapter (special tool) in its place. Fit the indicator switch and the oil pressure gauge on the adapter, and start the engine. The standard pressure is 4 kg/cm<sup>2</sup> (57 psi) when the engine is at 4,000 rpm and the engine oil temperature is at approximately 80°C (176°F).



If the oil pressure is significantly below the standard pressure, inspect the engine oil pump (Pg. 126). If the pump is not at fault, inspect the rest of the lubrication system.

- NOTES:** 1. Apply a non-permanent locking agent to the switch threads before installing it back on the crankcase.  
2. Warm up the engine before measuring the oil pressure.

**Oil pressure indicator switch inspection**

The switch should turn on the warning light whenever the ignition switch is on with the engine not running. If the light does not go on, disconnect the

lead from the switch, and use an ohmmeter to check for continuity between the switch terminal and the switch body. A reading of zero ohms indicates that the switch is not at fault and the trouble is either defective wiring or a burned-out indicator bulb. If the ohmmeter does not read zero ohms, the switch is defective.

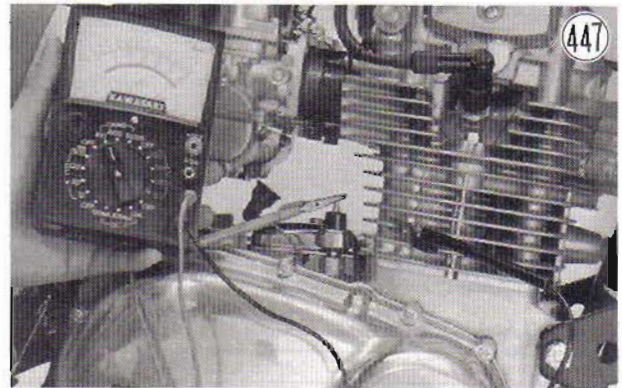

The switch should turn off the warning light whenever the engine speed rises above 1,500 rpm. If the light stays on, stop the engine, disconnect the lead from the switch, and connect the ohmmeter between the switch terminal and the engine (chassis ground). The meter should read zero ohms when the engine is off and infinity when the engine is running above 1,500 rpm. If the meter reads zero ohms when the engine is running above 1,500 rpm, stop the engine and measure the oil pressure (Pg. 125). If the pressure is near the standard value, replace the oil pressure indicator switch for a new one.

**NOTE:** When installing a new switch, use a non-permanent locking agent on the switch threads (Pg. 175, 177).

**Relief valve wear**

Measure the diameter of the valve piston and the inside diameter of the valve body. Subtract the valve piston diameter from the valve body inside diameter to determine the amount of valve wear. If the clearance exceeds the service limit, replace the valve piston. If the piston and the inside wall of the valve body are scratched, replace the relief valve.

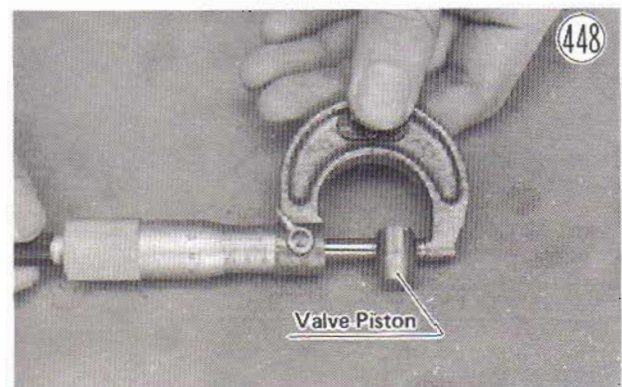

**Table 58 Relief Valve Wear**

Standard	Service Limit
0.020~0.103 mm	0.13 mm

## 126 MAINTENANCE

### Relief valve spring tension

Measure the valve spring free length with vernier calipers. If the length is less than the service limit, replace the spring.

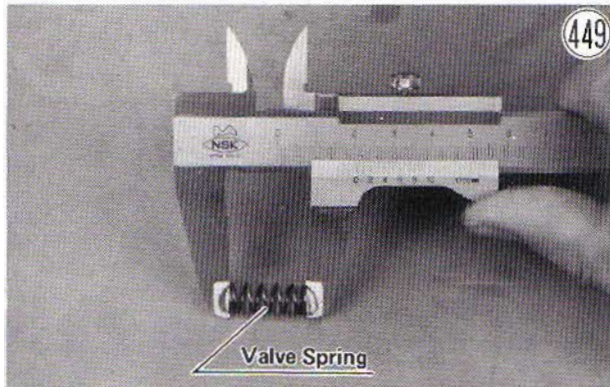

**Table 59 Valve Spring Free Length**

Standard	Service Limit
20.6 mm	19 mm

### Engine Oil Pump

The oil pump, installed in the right side of the lower crankcase half, is a simple trochoid type with an outer and an inner rotor. The gear on the pump is driven in direct proportion to engine rpm by a gear attached to the rear of the clutch housing.

If the oil pump becomes worn, it may no longer be able to supply oil to lubricate the engine adequately.

#### Outer rotor/inner rotor clearance

Measure the clearance between the outer rotor and inner rotor with a thickness gauge. If the clearance exceeds the service limit, replace the rotors.

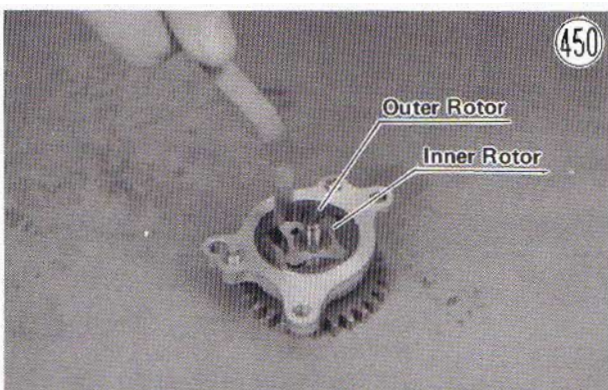
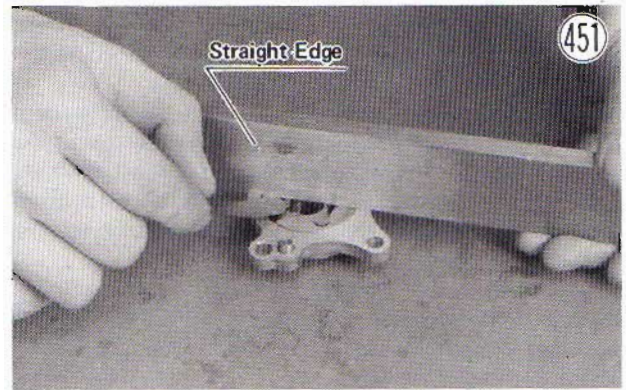

**Table 60 Outer Rotor/Inner Rotor Clearance**

Standard	Service Limit
0.025~0.115 mm	0.21 mm

#### Rotor side wear

Lay a straight edge on the oil pump body, and measure the clearance between the straight edge and the rotors with a thickness gauge. If the clearance exceeds the service limit, replace the rotors.

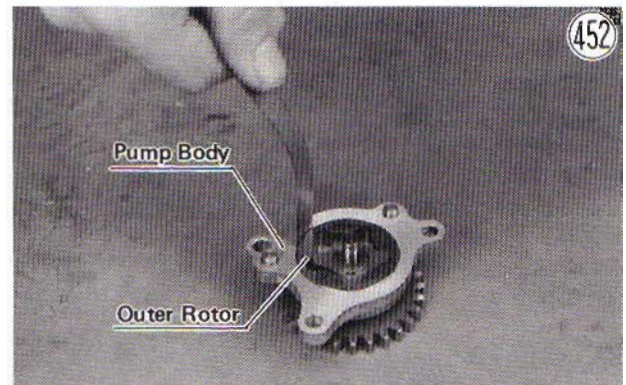

**Table 61 Rotor Side Wear**

Standard	Service Limit
0.03~0.09 mm	0.15 mm

#### Outer rotor/pump body clearance

Measure the clearance between the outer rotor and the pump body with a thickness gauge. If the clearance exceeds the service limit, replace either the pump body or the outer rotor depending on which is excessively worn.



**Table 62 Outer Rotor/Pump Body Clearance**

Standard	Service Limit
0.10~0.15 mm	0.25 mm

### Oil Filter

The oil filter, located in the lower part of the crankcase, cleanses the oil from the oil pump by filtration before the oil is used for lubrication.

As the filter element becomes dirty and clogged, its filtering effect is impaired. If it becomes so clogged that it seriously impedes oil flow, a pressure bypass valve in the center of the oil filter bolt opens so that sufficient oil will still reach the parts of the engine needing lubrication. When the filter becomes clogged such that the oil pressure difference between the inlet and outlet for the filter reaches 1.3~1.7 kg/cm<sup>2</sup> (18~24 psi), the oil on the inlet side pushing on the valve spring opens the valve, allowing oil to flow to the main oil passage bypassing filtration.

Oil Filter

453

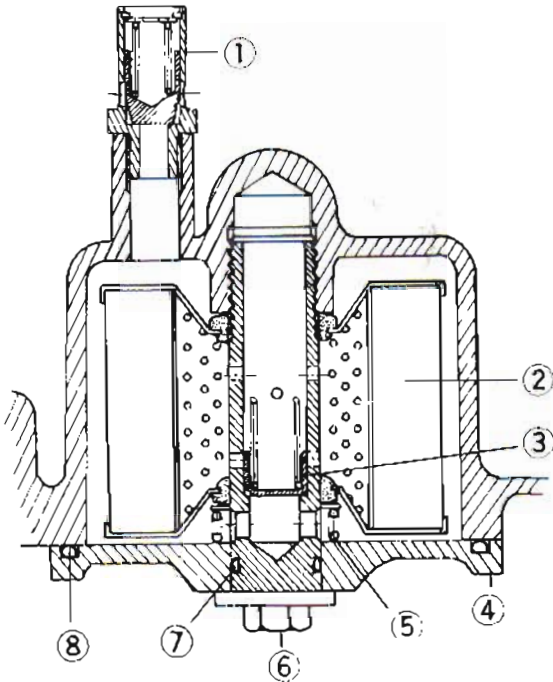

1. Relief Valve
2. Filter Element
3. Bypass Valve
4. Filter Base
5. Spring
6. Filter Bolt
7. O Ring
8. O Ring

Since any metal particles or other foreign matter in the oil reaching the crankshaft and transmission accelerates wear and shortens engine life, the oil filter should never be neglected.

Replace the filter element in accordance with the periodic maintenance chart (Pg. 172) since it quickly becomes clogged with metal filings from the engine and transmission breaking in. Subsequently, replace the element at every other oil change. When the filter is removed for element replacement, wash it in a high flash point solvent of some kind and check the condition of the O ring. If the O ring is worn or deteriorated, replace it to avoid oil leakage.

Oil Breather

The oil breather is located on the top of the cylinder head cover. The underside of the breather opens to the crankcase, while the upper part connects through the breather hose to the air cleaner. Its function is to minimize crankcase pressure variations caused by crankshaft and piston movement and to recycle blowby gas.

Gas blowby is the combustion chamber gas escaping past the rings into the crankcase. A small amount is unavoidable, but gas blowby increases as cylinder wall and piston ring wear progresses. If not efficiently removed, blowby gas will seriously contaminate the engine oil.

Recycling blowby gas means more efficient combustion, but the oil mist resulting from transmission gear movement must first be removed. The mixture of blowby gas and oil mist passes through a maze in the breather, which separates most of the oil from the gas. The oil which is separated from the gas returns to the bottom of the crankcase passing by the tachometer gear and camshaft chain. The gas together with a little oil is drawn through the breather hose into the air cleaner case. Here the remaining oil separates and passes through a hose to the outside, and the gas is drawn through the air cleaner element and carburetors into the engine again for combustion.

FUEL TANK

The fuel tank capacity is 14 liters, 3 liters of which form the reserve supply. A cap is attached to the top of the tank, and a fuel tap to the bottom at one side. An air vent is provided in the cap so that, when the tap is turned on, low pressure, which would hinder or prevent fuel flow to the carburetor, will not develop in the tank.

Fuel tap construction is shown in Fig. 454. The fuel tap has three positions: stop, on, and reserve. With the tap in the stop position, no fuel will flow through the tap; with the tap in the on position, fuel flows through the tap by way of the main pipe until only the reserve supply is left in the tank; with the tap in the reserve position, fuel flows through the tap from the bottom of the tank. The fuel tap contains a strainer and a sediment cup to filter out dirt and collect water.

Fuel Tap

454

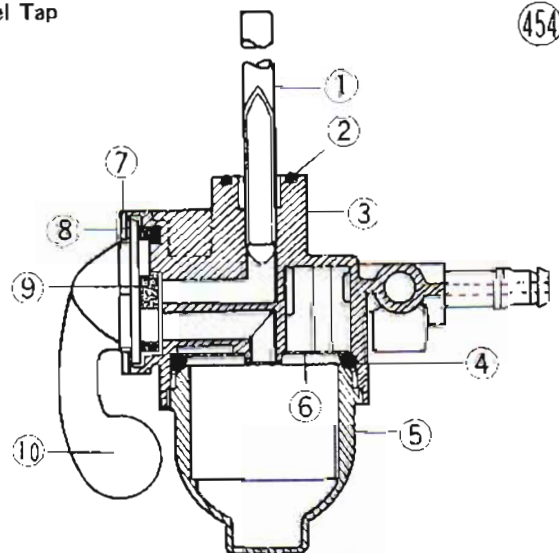

- |                 |                 |
|-----------------|-----------------|
| 1. Main Pipe    | 6. Strainer     |
| 2. O Ring       | 7. Plate        |
| 3. Body         | 8. Wave Washer  |
| 4. O Ring       | 9. Valve Gasket |
| 5. Sediment Cup | 10. Lever       |

### Inspection and cleaning

If fuel leaks from the cap or from around the fuel tap, the cap or tap O ring may be damaged. Visually inspect these parts, and replace if necessary.

Examine the air vent in the cap to see if it is obstructed. Use compressed air to clear an obstructed vent.

Periodically inspect and clean the fuel tap strainer and the sediment cup, using a high flash point solvent of some kind and a fine brush on the strainer. If the strainer is damaged, it must be replaced. If the sediment cup contains much water or dirt, the fuel tank and the carburetors may also need to be cleaned.

To clean out the fuel tank, disconnect the fuel hose, remove the fuel tap, and flush out the tank with a high flash point solvent of some kind.

To drain the carburetor float bowls, remove the plug at the bottom of each carburetor. For thorough cleaning, remove and disassemble the carburetors (Pg. 29).

## WHEELS

Wheel construction is shown in Figs. 456 and 457. The following sections, Pgs. 128 ~ 132, cover the tires, rim and spokes, axle, grease seals, and wheel bearings. For the brakes, see Pgs. 134 ~ 141.

## TIRES

The tires are designed to provide good traction and power transmission during acceleration and braking even under bad surface conditions when they are inflated to the correct pressure and not overloaded. The maximum recommended load in addition to vehicle weight is 136 kg.

If the tires are inflated to too high a pressure, riding becomes rough, the center portion of the tread wears quickly, and the tires are easily damaged.

If inflation pressure is too low, the shoulder portions wear quickly, the cord suffers damage, fuel consumption is high, and handling is poor. In addition, heat builds up at high speeds, and tire life is greatly shortened.

To ensure safe handling and stability, use only the recommended standard tires for replacement, inflating them to the standard pressure. However, for continuous high speed travel, increase the tire pressure from 0.2~0.4 kg/cm<sup>2</sup> (3 ~ 6 psi) in order to minimize heat buildup. Also, a certain variation from the standard pressure may be desired depending on road surface conditions (rain, ice, rough surface, etc.).

Table 63 Tires, Air Pressure (measured when cold)

	Make	Size	Air Pressure
Front	Yokohama Y982 Nylon	3.25S-18 4PR	1.9 kg/cm <sup>2</sup> (27 psi)
Rear	Yokohama Y985 Nylon	3.50S-18 4PR	2.0 kg/cm <sup>2</sup> (28 psi)

### Tire wear, damage

Tires must not be used until they are bald, or if they are cut or otherwise damaged. As the tire tread wears down, the tire becomes more susceptible to puncture and failure. 90% of tire failures occur during the last 10% of tire life.

Visually inspect the tire for cracks and cuts, replacing the tire in case of bad damage. Remove any imbedded stones or other foreign particles from the tread. Swelling or high spots indicate internal damage, requiring tire replacement unless the damage to the fabric is very minor.

Measure the depth of the tread with a depth gauge, and replace the tire if tread depth is less than the service limit.

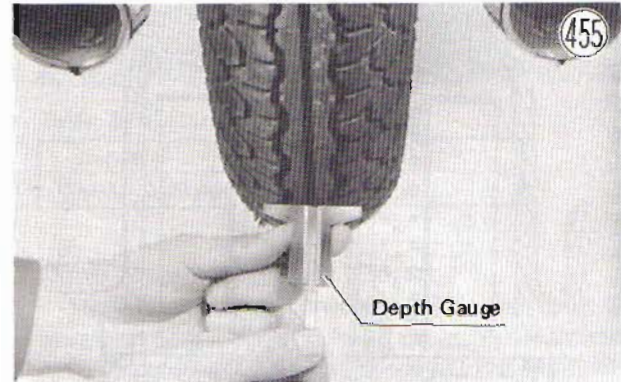

Table 64 Tire Tread Depth

	Standard	Service Limit	
		Normal speed	over 130 kph
Front	4.4 mm	1 mm	1 mm
Rear	6.3 mm	2 mm	3 mm

## RIM, SPOKES

The rim of each wheel is made of steel and is connected to the hub by the spokes. A rim band around the outside center of the rim keeps the tube from coming into direct contact with the rim and the spoke nipples.

The spokes are connected to the hub at a tangent and in different directions so that different spokes bear the brunt of the load during different conditions. With the spokes doing specialized work, the strength of the spokes can be used more effectively.

When the motorcycle is at rest (Fig. 458 A), the spokes above the axle are stretched and tense, while the spokes below the axle are slightly loose and do not provide support. During acceleration (B), the spokes running to the hub in the direction of rotation are stretched, while during deceleration or braking (C), the spokes running to the hub opposite to the direction of rotation are the ones that are stretched. In both cases B & C, the spokes that are not stretched (omitted from the diagram) are slightly loose and do not provide support. A damping action to the shock from the ground is achieved by flexing of the spokes since they are arranged in this cross pattern instead of running straight from the hub to the rim.

Since the spokes must withstand this repeated stress, it is important to take sufficient care that the spokes are not allowed to loosen and that they are tightened evenly. Loose or unevenly tightened spokes cause the rim to warp, increase the possibility of spoke breakage, and hasten ripple and spoke metal fatigue.

Front Wheel

456

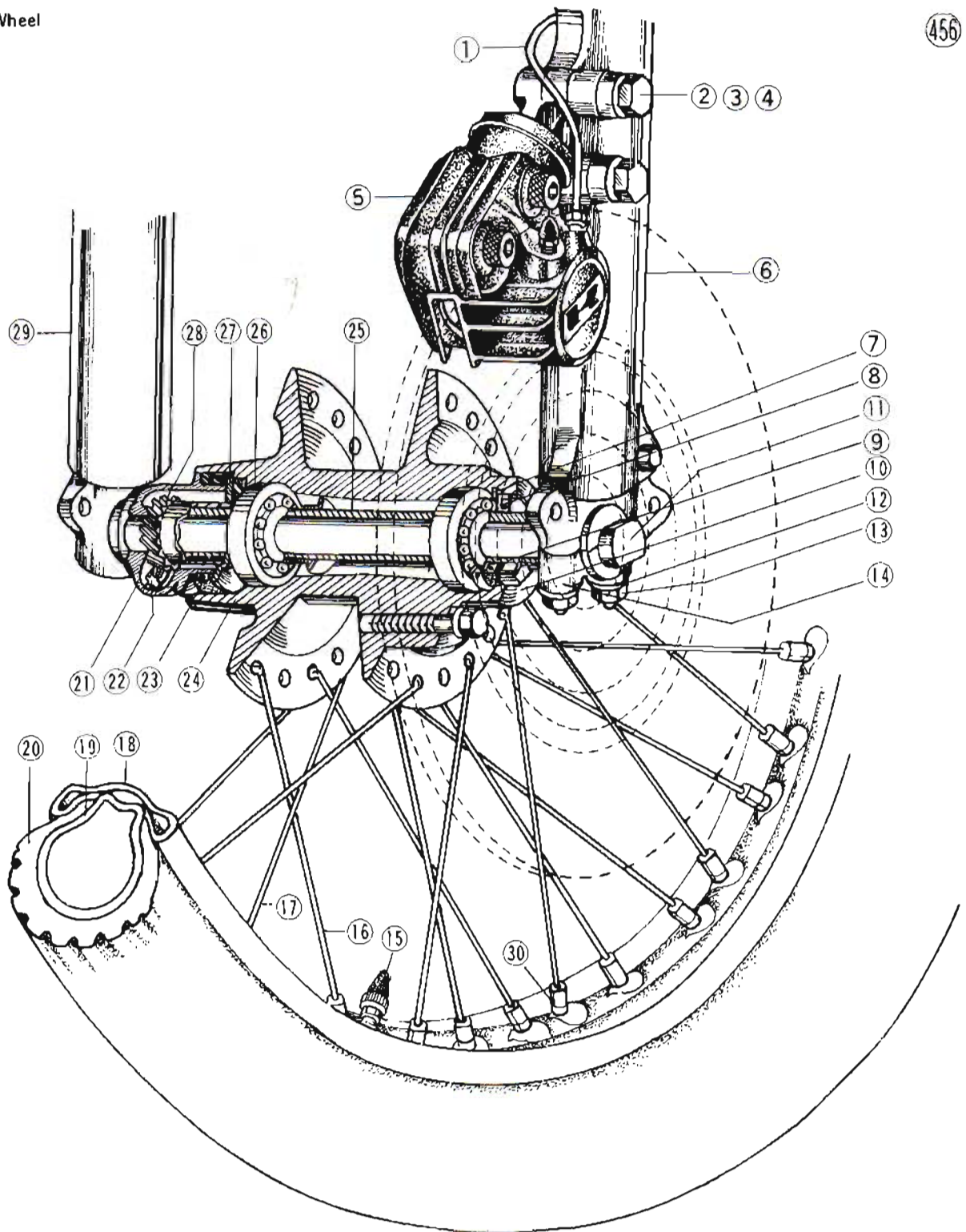

- |                              |                 |                                |
|------------------------------|-----------------|--------------------------------|
| 1. Brake Pipe                | 11. Axle        | 21. Speedometer Gear Housing   |
| 2. Bolt                      | 12. Lock Washer | 22. Speedometer Pinion         |
| 3. Lock Washer               | 13. Nut         | 23. Grease Seal                |
| 4. Washer                    | 14. Axle Clamp  | 24. Front Hub                  |
| 5. Caliper                   | 15. Valve Stem  | 25. Distance Collar            |
| 6. Left Front Shock Absorber | 16. Inner Spoke | 26. Bearing                    |
| 7. Circlip                   | 17. Outer Spoke | 27. Gear Drive                 |
| 8. Grease Seal               | 18. Rim         | 28. Speedometer Gear           |
| 9. Circlip                   | 19. Tube        | 29. Right Front Shock Absorber |
| 10. Cap                      | 20. Tire        | 30. Nipple                     |

# 130 MAINTENANCE

## Rear Wheel

### Brake Lining Wear Indicator 457

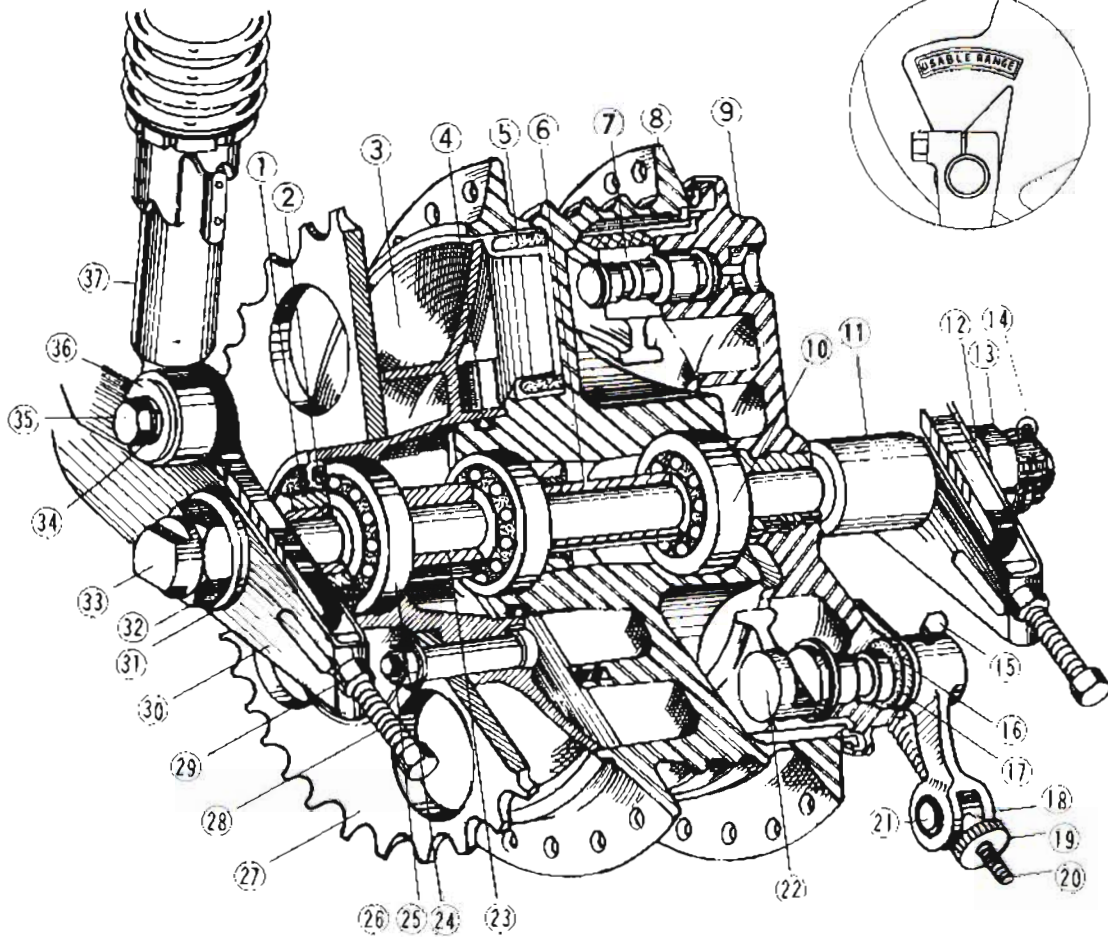

- |                        |                                 |                     |                         |
|------------------------|---------------------------------|---------------------|-------------------------|
| 1. Collar              | 11. Axle Sleeve                 | 20. Brake Rod       | 30. Chain Adjuster      |
| 2. Grease Seal         | 12. Washer                      | 21. Joint           | 31. Washer              |
| 3. Wheel Coupling      | 13. Axle Nut                    | 22. Camshaft        | 32. Coupling Sleeve Nut |
| 4. O Ring              | 14. Cotter Pin                  | 23. Coupling Sleeve | 33. Axle                |
| 5. Shock Damper Rubber | 15. Bolt                        | 24. Bearing         | 34. Lock Washer         |
| 6. Distance Collar     | 16. Brake Lining Wear Indicator | 25. Nut             | 35. Bolt                |
| 7. Brake Shoe          | 17. Gasket                      | 26. Double Washer   | 36. Washer              |
| 8. Rear Hub            | 18. Cam Lever                   | 27. Sprocket        | 37. Rear Shock Absorber |
| 9. Brake Panel         | 19. Adjusting Nut               | 28. Adjusting Bolt  |                         |
| 10. Bearing            |                                 | 29. Nut             |                         |

## Spoke Force

458

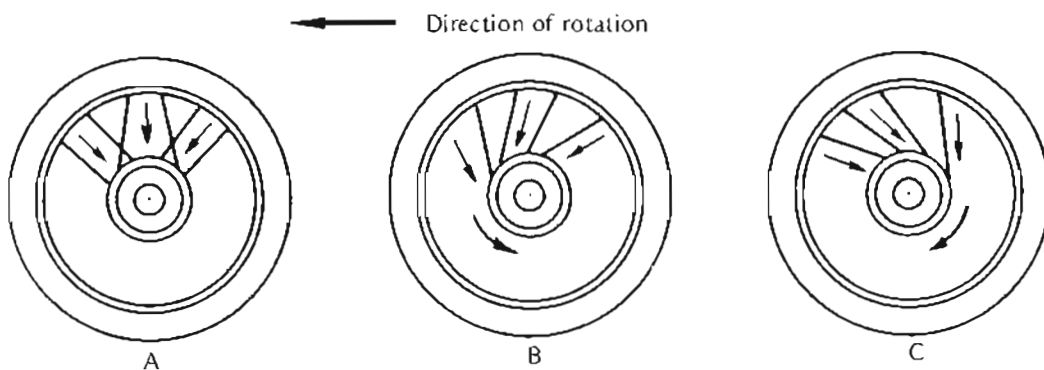

Table 65 Rim, Spoke Size

	Rim	Spokes	
		Inner	Outer
Front	1.85Bx18	#8x#9x174.5	#8x#9x174.0
Rear	1.85Bx18W	#8x#9x148.0	#8x#9x147.5

**NOTE:** The rim size in Table 65 is outer width by diameter, both in inches. The "W" means that the rim is welded. The spoke size is diameter number by length in millimeters. The two numbers for diameter size mean that each spoke has two diameters. To make the spoke more resistant to breakage, the diameter is greater near the hub.

**Spoke breakage**

If any spoke breaks, it should be replaced immediately. A missing spoke places an additional load on the other spokes, which will eventually cause other spokes to break.

Periodically check that all the spokes are tightened evenly since they stretch a certain amount during use. Standard spoke tightening torque is 25 ~ 30 kg-cm (22 ~ 26 in-lbs). Over or under tightening may cause breakage.

**Rim runout**

Set a dial gauge to the side of the rim, and rotate the wheel to measure axial runout. The difference between the highest and lowest dial reading is the amount of runout.

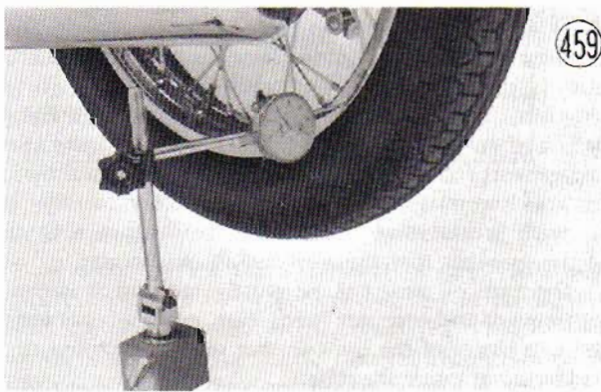

Set the dial gauge to the inner circumference of the rim, and rotate the wheel to measure radial runout. The difference between the highest and lowest dial reading is the amount of runout.

Table 66 Rim Runout

	Standard	Service Limit
Axial	under 1 mm	3 mm
Radial	under 1 mm	2 mm

A certain amount of rim warp (runout) can be corrected by recentering the rim; that is, loosen some spokes and tighten others to change the position of different parts of the rim. If the rim is badly bent, however, it should be replaced.

**AXLE**

A bent axle causes vibration, poor handling, and instability.

To measure axle runout, remove the axle, place it in V blocks that are 100 mm apart, and set a dial gauge to the axle at a point halfway between the blocks. Turn the axle to measure the runout. The amount of runout is the amount of dial variation.

If runout exceeds the service limit, straighten the axle or replace it. If the axle cannot be straightened to within tolerance, or if runout exceeds 0.7 mm, replace the axle.

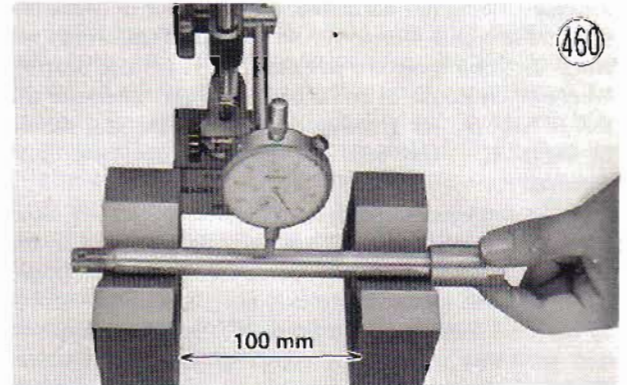

Table 67 Axle Runout/100 mm

	Standard	Service Limit
Front	0.1 mm	0.2 mm
Rear	0.05 mm	0.2 mm

**GREASE SEALS, WHEEL BEARINGS**

A grease seal is fitted in both sides of the front hub and in the left side of the rear hub. Each grease seal is a rubber ring equipped with a steel band on its outer circumference. The grease seal inner rib is held against the axle sleeve by a wire spring band. Since the grease seal not only seals in the wheel bearing grease but also keeps dirt and moisture from entering the hub, the use of a damaged grease seal will cause the wheel bearing to wear quickly.

A wheel bearing is fitted in both sides of each hub and in the rear wheel coupling. Since worn wheel bearings will cause play in the wheel, vibration, and instability, they should be cleaned, inspected, and greased periodically.

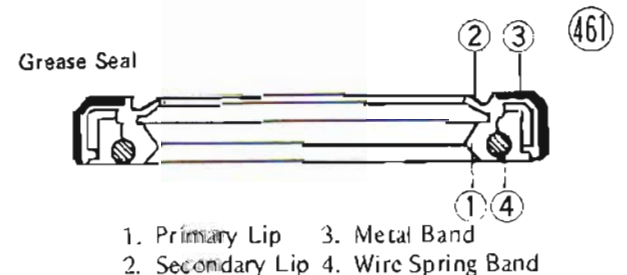

- 1. Primary Lip
- 2. Secondary Lip
- 3. Metal Band
- 4. Wire Spring Band

Table 68 Grease Seals, Wheel Bearings

	Front Wheel		Rear Wheel		
	Hub Left	Hub Right	Coupling	Hub Left	Hub Right
Bearing	#6302	#6302	#6205	#6303	#6303Z
Grease Seal	WTC22427	WTC40528	WTC35527	—	—

### Inspection and lubrication

If the grease seals are examined without removing the seals themselves, look for discoloration (indicating the rubber has deteriorated), hardening, damage to the internal ribbing, or other damage. If the seal or internal ribbing has hardened, the clearance between the seal and the axle sleeve will not be taken up, which will allow dirt and moisture to enter and reach the bearing. Whenever in doubt as to its condition and whenever the seal is removed for greasing the bearing, the seal should be replaced. The seals are generally damaged upon removal.

Since the wheel bearings are made to extremely close tolerances, the wear cannot normally be measured. Wash the bearing with a high flash point solvent of some kind, dry it (do not spin it while it is dry), and oil it. Spin it by hand to check its condition. If it is noisy, does not spin smoothly, or has any rough spots, it must be replaced. If the same bearing is to be used again, re-wash it with a high flash point solvent of some kind, dry it, and pack it with good quality bearing grease before installation. Turn the bearing around by hand a few times to make sure the grease is distributed uniformly inside the bearing, and wipe the old grease out of the hub before bearing installation. Clean and grease the wheel-bearings and the front hub gear housing (speedometer gear) in accordance with the periodic maintenance chart (Pg. 172).

### REAR WHEEL COUPLING

The rear wheel coupling connects the rear sprocket to the wheel. The forces that are transmitted between the rear sprocket and the rear hub are transmitted through rubber shock dampers in the coupling to absorb some of the shock resulting from sudden changes in torque due to acceleration or braking.

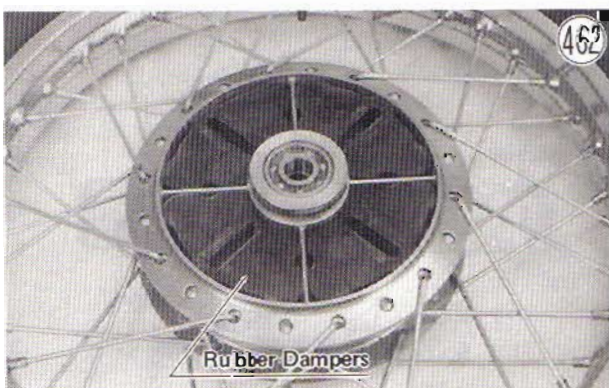

### Damper inspection

Remove the rear wheel coupling (Pg. 82), and inspect the rubber dampers.

Replace the dampers if any appear damaged or deteriorated.

### DRIVE CHAIN

The drive chain used to transmit the engine power to the rear wheel is the Enuma EK530SH-G 100 link chain. This chain is provided with a master link to facilitate removal and replacement. To minimize any chance of the master link dislodging, the master link is fitted with the closed end of the "U" pointed in the direction of chain rotation. See Fig. 463.

#### Direction of Chain Rotation

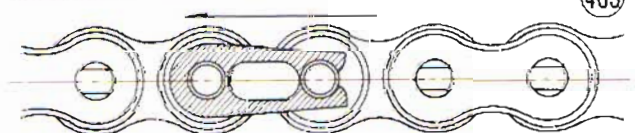

Chain construction is shown in Fig. 464. Most chain wear occurs between the pins and bushings, and between the bushings and rollers, rather than on the outside of the rollers. This wear causes the chain to lengthen. If the chain is left unadjusted, the lengthening will lead to noise, excessive wear, breakage, and disengagement from the sprockets. If the chain is allowed to wear too much, the distance from roller to roller is so much greater than the distance between each tooth of the sprocket that the wear rapidly accelerates.

The rate of wear can be greatly reduced, however, by frequent and adequate lubrication, especially between the side plates of the links so that oil can reach the pins and bushings inside the rollers.

#### Wear

When the chain has worn so much that it is more than 2% longer than when new, it is no longer safe for use and should be replaced. Whenever the chain is replaced, inspect both the engine and rear sprockets, and replace for new ones if necessary. Overworn sprockets will cause a new chain to wear quickly.

Since it is impractical to measure the entire length of the chain, determine the degree of wear by measuring a 20 link length of the chain. Stretch the chain taut either by using the chain adjuster, or by hanging a 10 kg weight on the chain. Measure the length of 20 links on a straight part of the chain from pin center of the 1st pin to pin center of the 21st pin. If the length is greater than the service limit, the chain should be replaced.

Drive Chain

464

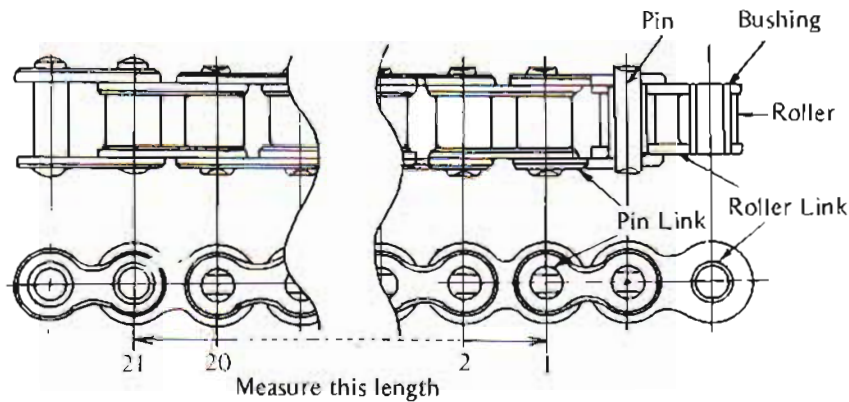

**NOTE:** The drive system was designed for use with the Enuma EK530SH-G 100 link chain. For maximum strength and safety, the Enuma EK530SH-G 100 link chain must be used for replacement.

The chain should be lubricated with a lubricant which will both prevent the exterior from rusting and also absorb shock and reduce friction in the interior of the chain. An effective, good quality lubricant specially formulated for chains is best for regular chain lubrication. If a special lubricant is not available, a heavy oil such as SAE 90 is preferred to a lighter oil because it will stay on the chain longer and provide better lubrication. Apply the oil to the sides of the rollers and between the side plates of the links so that oil will penetrate to the pins and bushings where most wear takes place. Wipe off any excess oil.

Dirt will cling to the oil and act as an abrasive, accelerating chain wear. Whenever the chain becomes particularly dirty, it must be cleaned in kerosene and then soaked in a heavy oil. Shake the chain while it is in the oil so that oil will penetrate to the inside of the rollers. If choosing to boil the chain in grease, better oil penetration to the interior is achieved, but care must be taken not to overheat the grease.



Table 69 Drive Chain Length

	Standard	Service Limit
20-link Length	317.5 mm	323 mm

Lubrication

In order for the chain to function safely and wear slowly, it should be properly lubricated in accordance with the periodic maintenance chart (Pg. 172). Lubrication is also necessary after riding through rain or on wet roads, or any time that the chain appears dry. Anytime that the motorcycle including the chain has been washed, the chain should be adequately lubricated on the spot in order to avoid rust.

SPROCKETS

There are two sprockets for the drive chain. A forward sprocket, or engine sprocket, is mounted on the end of the output shaft and is used to drive the chain. A rear sprocket is connected to the rear wheel hub through the rear wheel coupling and is driven by the chain to turn the rear wheel.

Sprockets that have become excessively worn cause noise with the chain and greatly accelerate chain and sprocket wear. The sprockets should be checked for wear any time that the chain is replaced. A warped rear sprocket destroys chain alignment such that the chain may break or jump from the sprockets when traveling at high speed. The sprockets should be checked for wear and the rear sprocket for warp any time that the chain is replaced.

Sprocket wear

Visually inspect the sprocket teeth. If they are worn as illustrated, replace the sprocket.

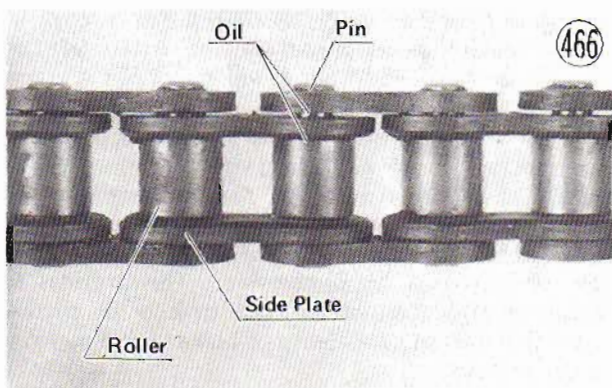

Sprocket Teeth

467

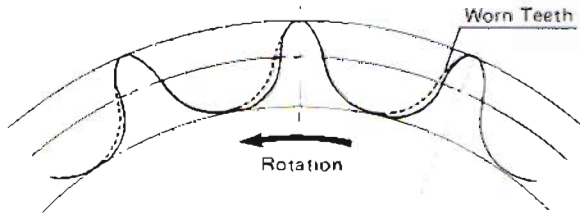

**NOTE:** If a sprocket requires replacement, the chain is probably worn also. Upon replacing a sprocket, inspect the chain.

Measure the diameter of the sprocket at the base of the teeth. If the sprocket is worn down to less than the service limit, replace the sprocket.

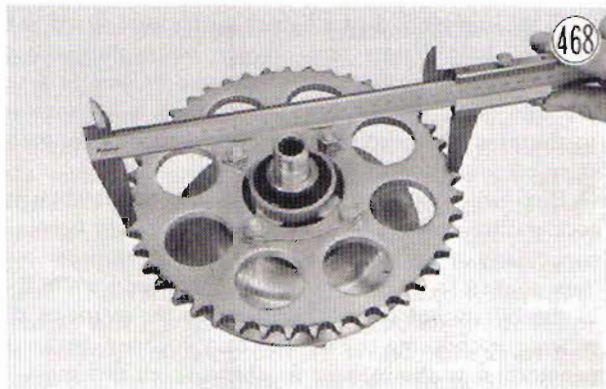

Table 70 Sprocket Diameter

	Standard	Service Limit
Engine	65.58~65.78 mm	64.8 mm
Rear	217.4 mm	215.5 mm

Rear sprocket warp

Elevate the rear wheel so that it will turn freely, and set a dial gauge against the rear sprocket near the teeth as shown in Fig. 469. Rotate the rear wheel. The difference between the highest and lowest dial gauge reading is the amount of runout (warp).

If the runout exceeds the service limit, replace the rear sprocket.



Table 71 Rear Sprocket Warp

Standard	Service Limit
under 0.3 mm	0.5 mm

DISC BRAKE

A hydraulic disc brake is used on the front wheel for its superior braking performance and high reliability. The major components of the disc brake are the brake lever, master cylinder, brake line, caliper assembly, and disc. The brake lever is pulled to pressurize the brake fluid to move a piston in the master cylinder. Fluid pressure operates the front brake light switch and is transmitted through the brake line to operate the caliper. The switch turns on the brake light, and the caliper grips the disc attached to the front wheel, slowing wheel rotation.

The brake fluid is an extra heavy duty type with a high boiling point to withstand the heat produced from friction of the caliper pads on the disc. Since the boiling point and thus the performance of the fluid would be reduced by contamination with water vapor or dirt from the air, the reservoir is sealed with a rubber diaphragm under the cap. This cap seal also prevents fluid evaporation and spillage should the motorcycle fall over. The fluid is further protected by rubber seals in the caliper assembly and at the master cylinder brake line fitting.

The master cylinder assembly includes the reservoir, piston, primary and secondary cups, non-return valve, check valve, and spring. The reservoir has two holes at the bottom: a relatively large supply port to supply fluid to the lines and a small relief port to admit excess fluid from the line. The primary and secondary cups stop the fluid from leaking back around the piston while the piston is moving forward to pressurize the line. The check valve stops fluid from suddenly returning from the brake line when the lever is released, and thereby smooths brake operation. The non-return valve is in the head of the piston; it stops backward fluid flow when the brake is applied, but when the brake lever is released, allows flow around the cup to fill the vacuum in front of the piston so that the piston can return easily.

The caliper assembly includes pad A, pad B, and the piston, which is inside the caliper cylinder. Through the caliper run two shafts, which also pass through the caliper holder to mount the assembly to the left fork shock absorber. When the piston forces pad A against the disc, the shaft portion of the caliper assembly slides through the holder such that pad B is also forced against the disc, both brake pads being kept parallel to the disc.

Unlike a drum-type brake, the components of the disc brake which perform the actual braking action, i.e., the disc and pads, are open to direct contact with the air flow past the motorcycle. This provides for excellent dissipation of the heat from brake friction, and minimizes any possibility of brake fade common to drum brakes.

Master Cylinder

(470)

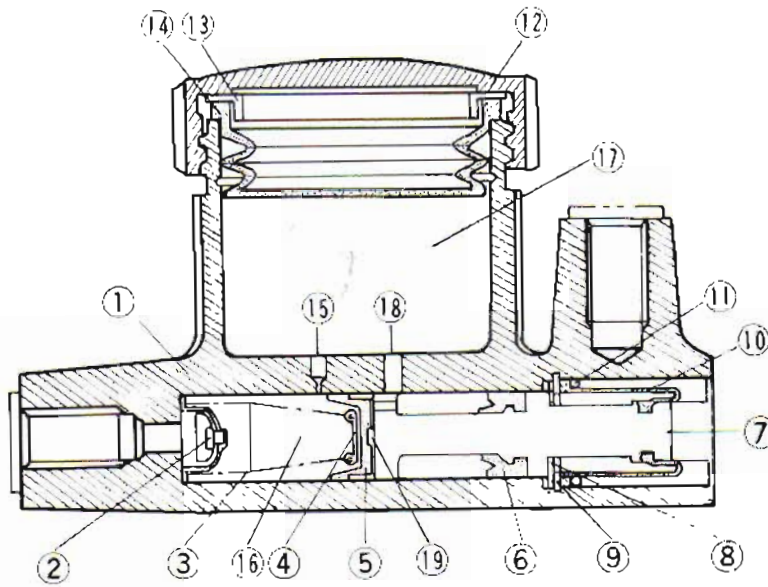

1. Master Cylinder Body
2. Check Valve
3. Spring
4. Spring Seal
5. Primary Cup
6. Secondary Cup
7. Piston
8. Stopper, Piston
9. Circlip
10. Dust Seal
11. Stopper, Dust Seal
12. Cap
13. Ring Plate
14. Diaphragm
15. Relief Port
16. Pressure Chamber
17. Reservoir
18. Supply Port
19. Non-return Valve

Caliper

(471)

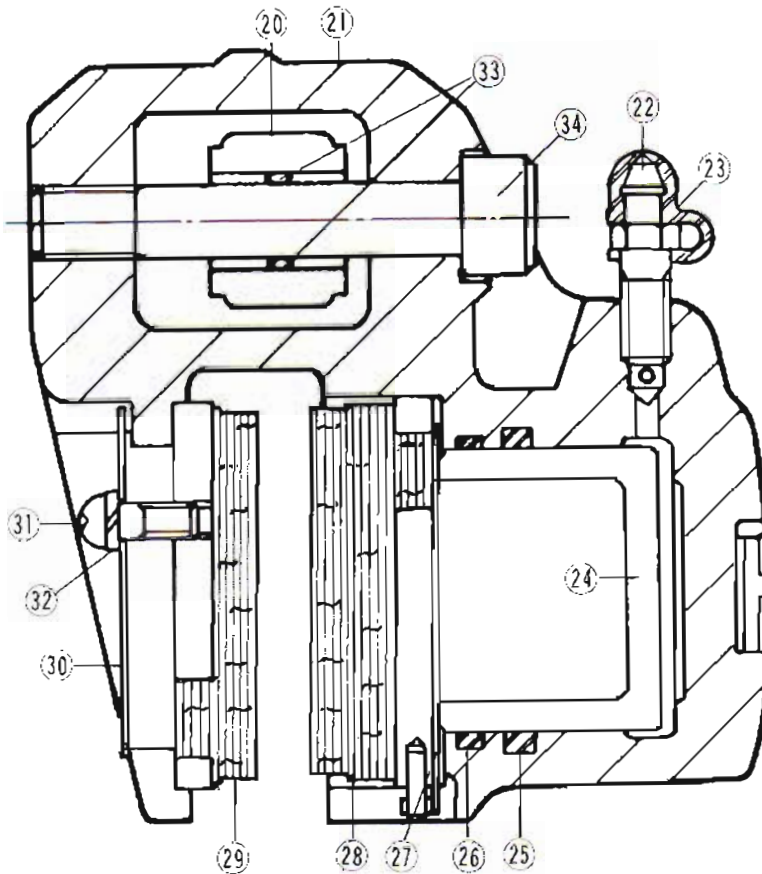

20. Holder
21. Caliper
22. Bleed Valve
23. Bleed Valve Cap
24. Piston
25. Fluid Seal
26. Piston Dust Seal
27. Anti-Squeak Shim
28. Pad A
29. Pad B
30. Metal Disc
31. Screw
32. Lock Washer
33. O Ring
34. Allen Bolt

When fluid pressure develops in the cylinder, the piston is pushed exerting pressure against the brake pad, which in turn presses against the brake disc. The pressurized fluid is prevented from leaking by a fluid seal fitted into the cylinder wall. The seal presses against the piston, and instead of sliding when the piston moves, the seal is only distorted, allowing no fluid leakage at all. When the brake lever is released and fluid pressure lowers, the elasticity of the seal returns the piston to its original position. After the brakes are used for a while and the pads wear slightly, the rubber seal will no longer be able to be distorted the additional amount that the piston travels. Instead, when piston travel forces the seal past its limit, the seal slips slightly on the piston, and then returns the piston to a new rest position not as far in. A small amount of fluid from the reservoir supplements the fluid in the brake line to compensate for the difference in piston position. Consequently, the length of the brake lever stroke remains unchanged, and the brake never needs adjustment.

The rubber seal and the cup at the head of the master cylinder piston are made of an fluid and heat resistant rubber composition for best performance and to prevent contamination of the brake fluid by rubber deterioration. For this reason only standard parts should be used.

**Rubber Seal**

472

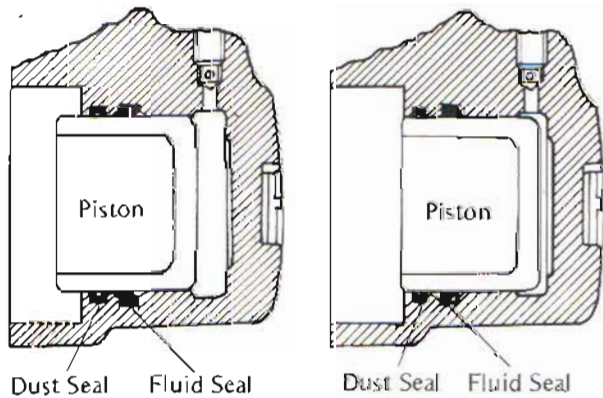

**Braking Stroke**

When the brake lever is pulled, the piston (7) in the master cylinder (1) is pushed and moves forward against the force of the return spring (3). At this time, the primary cup (5) at the head of the piston closes the small relief port (9), which connects the pressure chamber (16) and the reservoir (17). Until this port is fully closed, the brake fluid does not start being pressurized, in spite of the forward movement of the piston.

The pressure stroke starts as soon as the relief port is closed. The piston compresses the brake fluid, which is being used as the pressure medium, forcing it through the check valve (2) and out into the brake line. The pressure is transmitted in the line to the cylinder portion of the caliper assembly, where it forces the piston towards the disc. Pad A (28) at the end of the piston is forced against the disc, but, since the disc is immovable, further pressure cannot move the pad any farther.

Instead, the entire caliper assembly moves in the opposite direction such that pad B is also forced against the disc. In this manner, the disc is gripped between the two pads, and the resulting friction slows wheel rotation.

**Braking Release Stroke**

When the brake lever is released, the piston in the master cylinder is quickly returned toward its rest position by the spring (3), and brake fluid pressure in the line and in the caliper master cylinder drops. The elasticity of the fluid seal (5) in the cylinder then returns the piston. This leaves no pressure against either pad A or B so that slight friction against the disc pushes them both a hairbreadth away from the disc.

As the master cylinder piston moves back further, the brake fluid in the line (which still has some pressure) rushes to fill the low pressure area in front of the primary cup at the piston head. But the fluid is prevented from moving quickly by the check valve, and the low pressure area in front of the piston is not relieved. At this time, fluid from the reservoir flows through the large supply port (18) into the space between the primary and secondary cups (6), through the non-return valve (19), and passes around the edges of the primary cup to fill the vacuum. When the piston has returned to its rest position against the stopper (8), the small relief port is uncovered, and, as the brake fluid returns from the line through the check valve, excess fluid passes through the relief port into the reservoir until the brake line pressure returns to zero.

**Brake Fluid**

When the brake is applied, heat is generated by the friction between the disc and the brake pads. While much of this heat is immediately dissipated, some of it is transmitted to the brake fluid and may raise fluid temperature to as high as 150°C (300°F) during brake operation. This temperature could boil the brake fluid and cause a vapor lock in the lines unless fluid with a high boiling point is used and has been kept from being contaminated with dirt, moisture, or a different type of fluid. Poor quality or contaminated fluid can also deteriorate the rubber parts of the brake mechanism, although a special rubber is used to make them resistant to deterioration from contact with the recommended brake fluids.

**Brake Fluid Boiling Point**

473

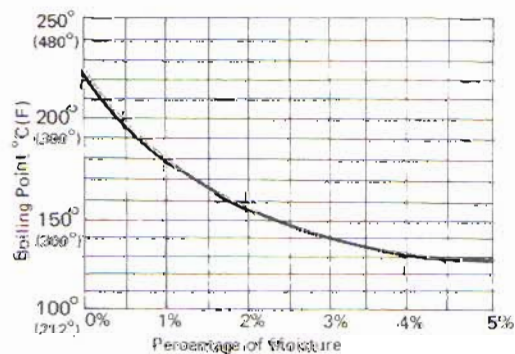

**WARNING**

When working with the disc brake, observe the precautions listed below.

1. Never reuse old brake fluid.
2. Do not use fluid from a container that has been left unsealed or that has been open a long time.
3. Do not mix two types of fluid for use in the brake. This lowers the brake fluid boiling point and could cause the brake to be ineffective. It may also cause the rubber brake parts to deteriorate. Recommended fluids are given in the table.

**NOTE:** The type of fluid originally used in the disc brake is not available in most areas, but it should be necessary to add very little fluid before the first brake fluid change. After changing the fluid, use only the same type thereafter.

**Table 72 Recommended Disc Brake Fluid**

Atlas Extra Heavy Duty Shell Super Heavy Duty Texaco Super Heavy Duty Wagner Lockheed Heavy Duty Girling Amber
--

The correct fluid will come in a can labeled D.O.T.3. Do not use fluid that does not have one of these markings.

4. Don't leave the reservoir cap off for any length of time to avoid moisture absorbing into the fluid.
5. Don't change the fluid in the rain or when a strong wind is blowing.
6. Except for the disc pads and disc, use only disc brake fluid, isopropyl alcohol, or ethyl alcohol for cleaning brake parts. Do not use any other fluid for cleaning these parts. Gasoline, motor oil, or any other petroleum distillate will cause deterioration of the rubber parts. Oil spilt on any part will be difficult to wash off completely and will eventually reach and break down the rubber used in the disc brake.
7. When handling the disc pads or disc, be careful that no disc brake fluid or any oil gets on them. Clean off any fluid or oil that inadvertently gets on the pads or disc with a high flash point solvent of some kind. Do not use one which will leave an oily residue. Replace the pads for new ones if they cannot be cleaned satisfactorily.
8. Brake fluid quickly ruins painted surfaces; any spilt fluid should be completely wiped up immediately.
9. If any of the brake line fittings or the bleed valve is opened at any time, **AIR MUST BE BLED FROM THE BRAKE.**
10. When installing or assembling the disc brake, tighten the disc brake fittings to the values given in Table 1. Improper torque may cause the brake to malfunction.

The graph of Fig. 473 shows how brake fluid contamination with moisture lowers the fluid boiling point. Although not shown in the graph, the boiling point also lowers as the fluid gets old, is contaminated with dirt, or if two different types of brake fluid are mixed.

**Changing the brake fluid**

The brake fluid should be changed in accordance with the periodic maintenance chart (Pg. 172) and whenever it becomes contaminated with dirt or water.

- Attach a clear plastic hose to the bleed valve on the caliper, and run the other end of the hose into a container.
- Open the bleed valve (counterclockwise to open), and pump the brake lever until all the fluid is drained from the line.
- Close the bleed valve, and fill the reservoir with fresh brake fluid.
- Open the bleed valve, squeeze the brake lever, close the valve with the lever held squeezed, and then quickly release the lever. Repeat this operation until the brake is filled and fluid starts coming out of the plastic hose. Replenish the fluid in the reservoir as often as necessary to keep it from running completely out.
- Bleed the air from the lines.

**Bleeding the brake**

The brake fluid has a very low compression coefficient so that almost all the movement of the brake lever is transmitted directly to the caliper for braking action. Air, however, is easily compressed. When air enters the brake lines, brake lever movement will be partially used in compressing the air. This will make the

lever feel spongy, and there will be a loss in braking power.

Bleed the air from the brake whenever brake lever action feels soft or spongy, after the brake fluid is changed, or whenever a brake line fitting has been loosened for any reason.

- Remove the reservoir cap, and check that there is plenty of fluid in the reservoir. The fluid level must be checked several times during the bleeding operation and replenished as necessary. If the fluid in the reservoir runs completely out any time during bleeding, the bleeding operation must be done over again from the beginning since air will have entered the line.
- With the reservoir cap off, slowly pump the brake lever several times until no air bubbles can be seen rising up through the fluid from the holes at the bottom of the reservoir. This bleeds the air from the master cylinder end of the line.

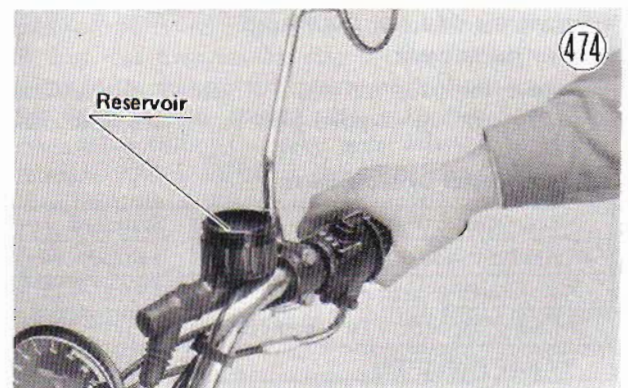

## 138 MAINTENANCE

- Replace the reservoir cap, and connect a clear plastic hose to the bleed valve at the caliper, running the other end of the hose into a container. Pump the brake lever a few times until it becomes hard and then, holding the lever squeezed, quickly open (turn counterclockwise) and close the bleed valve. Then, release the lever. Repeat this operation until no more air can be seen coming out into the plastic hose. Check the fluid level in the reservoir every so often, replenishing it as necessary.
- When air bleeding is finished, replace the rubber cap on the bleed valve, and check that the brake fluid is filled to the line marked in the reservoir (handlebar turned so that the reservoir is level).

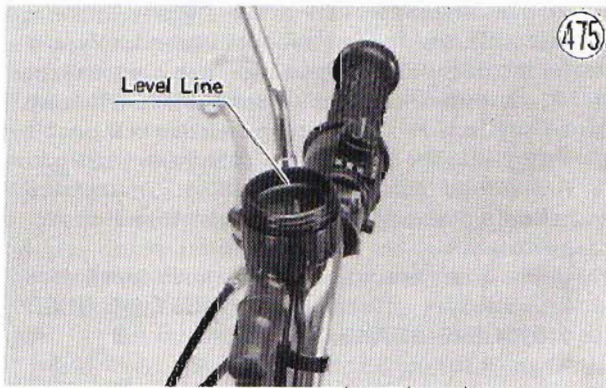

### Master cylinder parts wear

When master cylinder parts are worn or damaged, proper brake fluid pressure cannot be obtained in the line, and the brake will not hold.

If the small relief port becomes plugged, especially with a swollen or damaged primary cup, the brake pads will drag on the disc.

- Check that there are no scratches, rust or pitting on the inside of the master cylinder, and that it is not worn past the service limit.
- Check the piston for these same faults.
- Inspect the primary and secondary cups. If a cup is worn, damaged, softened (rotted), or swollen, replace it. When inserting the cup into the cylinder, see that it is slightly larger than the cylinder (standard values given in the table). If fluid leakage is noted at the brake lever, the cups should be replaced. (The secondary cup is part of the piston assembly. Replace the piston if the secondary cup requires replacement).
- Check that the spring is not damaged and is not shorter than the service limit.
- Replace the dust seal if damaged.

### Caliper parts wear

Inspect the pads for wear. If either pad is worn down through the stepped portion, replace both pads

Table 73 Master Cylinder Parts

Measurement	Standard	Service Limit
Cylinder inside diameter	14.000~14.043 mm	14.08 mm
Piston outside diameter	13.957~13.984 mm	13.90 mm
Primary, secondary cup diameter	14.65~15.15 mm	14.50 mm
Spring length (free)	51.0 mm	48.0 mm

as a set. If any grease or oil spills on the pads, wash it off with trichloroethylene or a high flash point solvent of some kind. Do not use one which will leave an oily residue. If the oil cannot be thoroughly cleaned off, replace the pads.

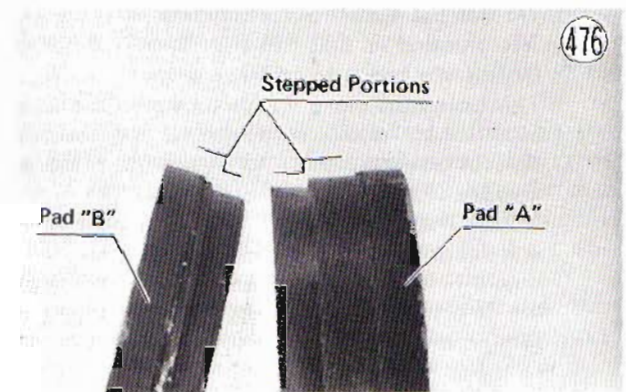

The fluid seal around the piston maintains the proper pad/disc clearance. If this seal is not satisfactory, one pad will wear more than the other, pad wear will increase, and constant pad drag on the disc will raise brake and brake fluid temperature.

Replace the fluid seal under any of the following conditions: (a) fluid leakage around pad A; (b) brakes overheat; (c) there is a large difference in A and B pad wear; (d) the seal is stuck to the piston. If the fluid seal is replaced, replace the dust seal as well. Also replace both seals every other time the pads are changed.

Replace the cylinder and piston if they are worn out of tolerance, badly scored, or rusty.

Check both seals and the O ring, and replace any that are cracked, worn, swollen or otherwise damaged.

Table 74 Caliper Parts

	Standard	Service Limit
Cylinder inside diameter	38.10~38.15 mm	38.17 mm
Piston outside diameter	37.97~38.02 mm	37.90 mm

### Brake line damage

The high pressure inside the brake line can cause fluid to leak or the hose to burst if the line is not properly maintained.

Bend and twist the rubber hose while examining it. Replace it if any cracks or bulges are noticed.

The metal pipe is made of plated steel, and will rust if the plating is damaged. Replace the pipe if it is rusted or cracked (especially check the fittings), or if the plating is badly scratched.

**Disc wear, warp**

Besides wearing down, the disc may warp. A warped disc will cause the brake pads to drag on the disc and wear down both the pads and disc quickly. Dragging will also cause overheating and poor braking efficiency. Poor braking can also be caused by oil on the disc. Oil on the disc must be cleaned off with trichloroethylene or a high flash point solvent of some kind. Do not use one which will leave an oily residue.

Jack up the motorcycle so that the front wheel is off the ground, and turn the handlebar fully to one side. Set up a dial gauge against the disc as illustrated, and measure disc runout. If runout exceeds the service limit, replace the disc.

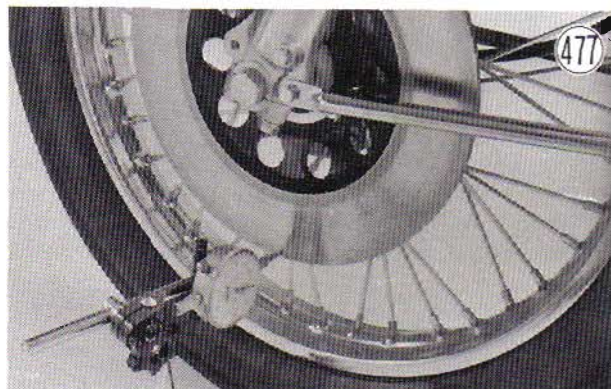

**Table 75 Disc Runout**

Standard	Service Limit
under 0.1 mm	0.3 mm

Measure the thickness of the disc at the point where it has worn the most. Replace the disc if it has worn past the service limit.

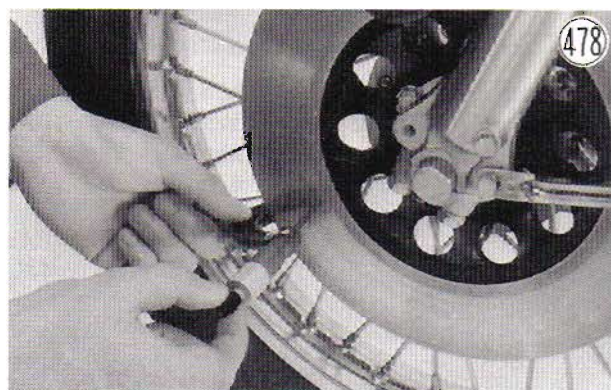

**Table 76 Disc Thickness**

Standard	Service Limit
6.95~7.05 mm	5.5 mm

**REAR BRAKE**

The rear wheel is equipped with a leading-trailing type of drum brake. "Leading-trailing" means that one of the two brake shoes leads, expanding against the drum in the direction of drum rotation, and the other shoe trails, expanding in the direction opposite drum rotation.

**Brake**

479

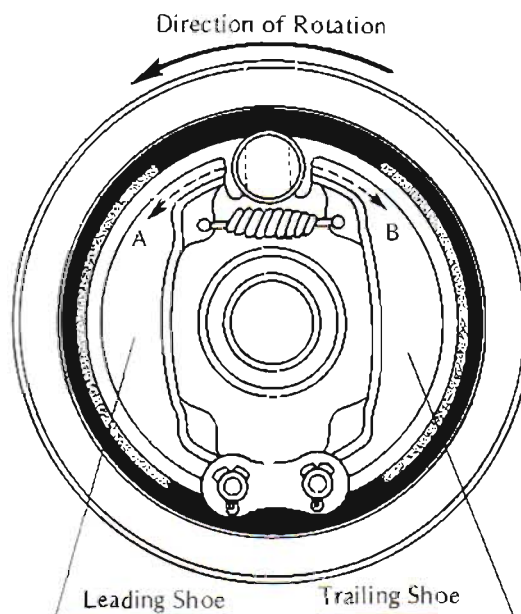

The force applied by the rider upon braking is transmitted into the interior of the brake by a camshaft. The force applied at the brake pedal is transmitted by a rod to the cam lever which then turns the camshaft. When the camshaft rotates, the large portion of the cam is forced between the two brake shoes. Since the shoes are only held together away from the drum by a spring, the cam, overcoming spring tension, pushes the shoes outward against the drum. The leading shoe rotates in direction "A", and the trailing shoe in direction "B" as shown in the diagram.

The friction between the linings and the drum, which decelerates the motorcycle, gradually wears down the brake shoe linings. On the outside of the brake panel is a brake lining wear indicator, which, as the brake is applied, moves in direct proportion to the distance that the brake shoe linings move to reach the brake drum. As the linings wear down, the lining surface has farther to travel before reaching the drum. The indicator accordingly travels farther until it finally points just to the left of the "U" in USABLE when the lining wear has reached the service limit.

Due to wear of the brake drum, shoe linings, and cam, periodic brake adjustment is required. However, if the brake parts become overworn, adjustment will not be sufficient to ensure safe brake operation. Not only can overworn parts crack (drum) and otherwise suffer damage as they lose their braking effectiveness, but, if the cam wears to the point where it turns nearly horizontal when the brake is fully applied, the brake may lock in the operated position, or brake pedal return may be very sluggish. All brake parts should be checked for wear in accordance with the periodic maintenance chart (Pg. 172).

**Brake drum wear**

Measure the inside diameter of the brake drum with calipers to determine wear. Since uneven drum wear will decrease braking effectiveness, take measurements at a

## 140 MAINTENANCE

minimum of two places. If the drum is worn unevenly or if it is scored, turn the drum down on a brake drum lathe or replace the hub. (Do not turn it down to the service limit, and do not turn it down if any diameter measurement exceeds the service limit). If any diameter measurement exceeds the service limit, replace the hub for a new one.

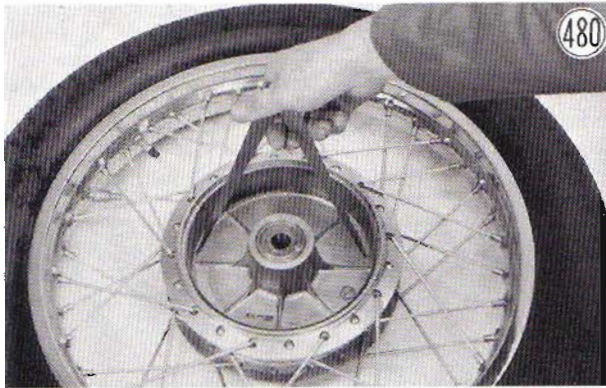
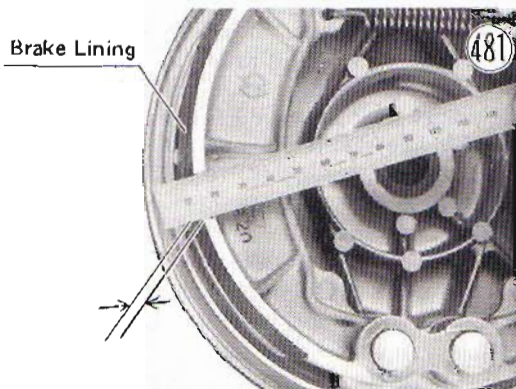

**Table 77 Brake Drum Inside Diameter**

Standard	Service Limit
180.0~180.2 mm	180.75 mm

### Brake shoe lining wear

Check the thickness of the brake linings, and replace both shoes as a set if the thickness at any point is less than the service limit. If the thickness of the brake linings is sufficient, check the linings for uneven wear, and file or sand down any high spots. With a wire brush, remove any foreign particles imbedded in the lining surface. Wash off any oil or grease with a high flash point solvent of some kind. Do not use one which will leave an oily residue. In case the linings are damaged or the surface cannot be restored by sanding and cleaning, the shoes must be replaced.

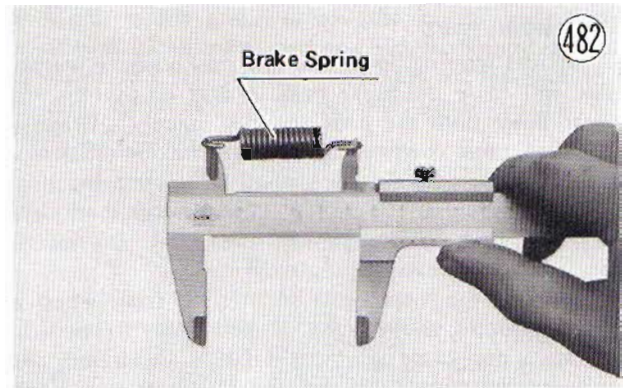

**Table 78 Brake Lining Thickness**

Standard	Service Limit
5.35~6.05 mm	2.5 mm

### Brake shoe spring tension

If the brake spring becomes stretched, it will not pull the shoes back away from the drum after the brake pedal is released, causing the shoes to drag on the drum. Remove the spring, and check its free length with vernier calipers. If it is stretched beyond the service limit, replace it for a new one.



**Table 79 Brake Spring Free Length**

Standard	Service Limit
56 mm	58 mm

### Camshaft, shaft hole wear

Excessive shaft to hole clearance will increase camshaft play and reduce braking efficiency.

Measure the shaft diameter with a micrometer, and replace it if it is worn down to less than the service limit.

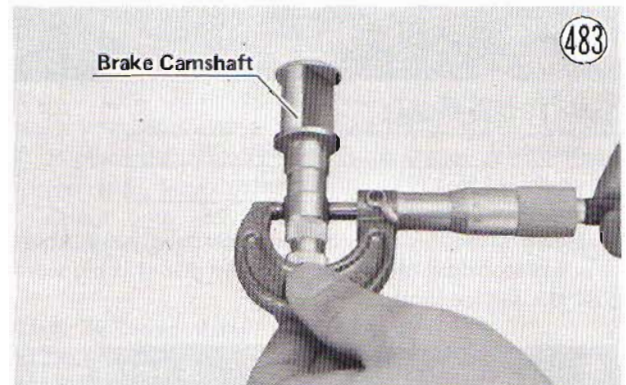

Measure the inside diameter of the camshaft hole, and replace the brake panel if the hole is worn past the service limit.

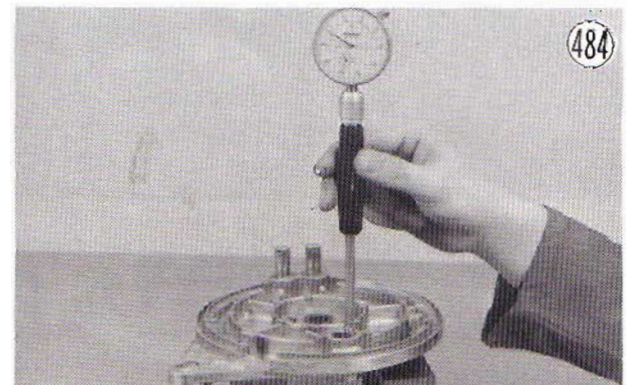
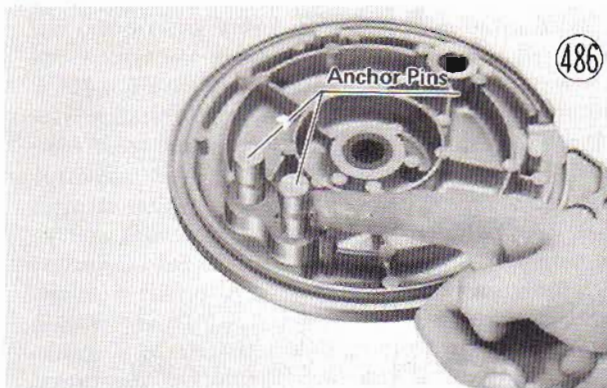
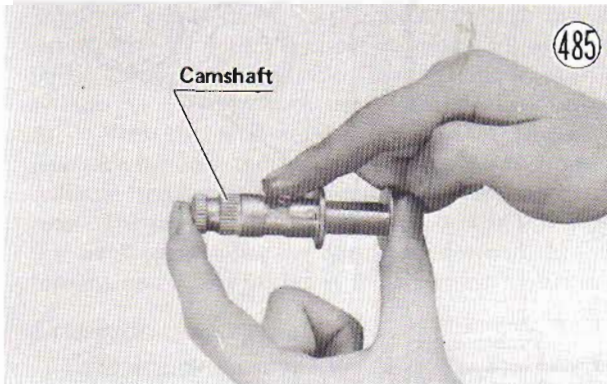

**Table 80 Brake Camshaft, Hole Diameter**

	Standard	Service Limit
Camshaft	16.957~16.984 mm	16.83 mm
Shaft Hole	17.000~17.027 mm	17.18 mm

**Lubrication**

Every time that the brake is disassembled, and in accordance with the periodic maintenance chart (Pg. 172), wipe out the old grease, and re-grease the brake pivot points. Apply grease to the brake shoe anchor pins, spring ends, and cam surface of the camshaft, and fill the camshaft groove with grease. Do not get any grease on the brake shoe linings, and wipe off any excess grease so that it will not get on the linings or drum after brake assembly.



**Steering Stem**

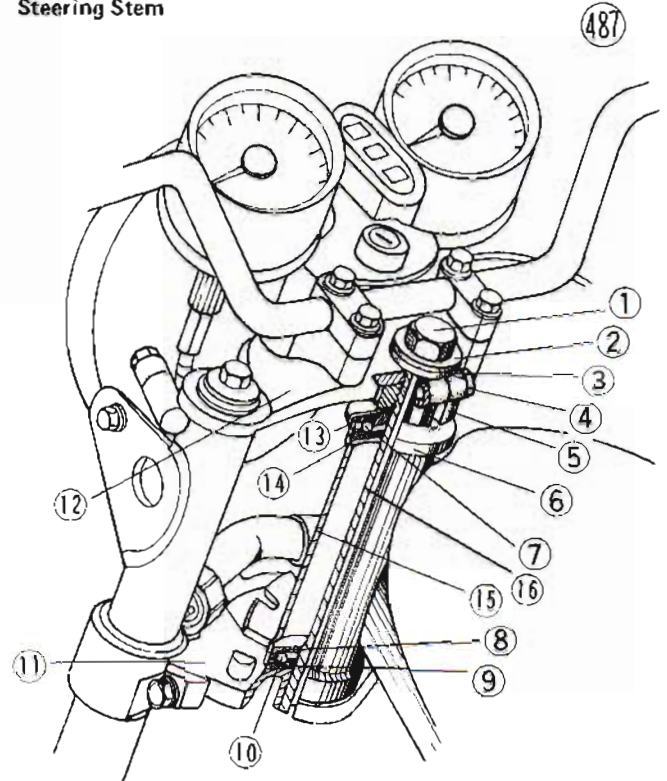

- |                           |                      |
|---------------------------|----------------------|
| 1. Stem Head Bolt         | 9. Lower Inner Race  |
| 2. Washer                 | 10. Steel Balls      |
| 3. Washer                 | 11. Stem Base        |
| 4. Stem Head Clamp Bolt   | 12. Stem Head        |
| 5. Steering Stem Lock Nut | 13. Upper Inner Race |
| 6. Steering Stem Cap      | 14. Upper Outer Race |
| 7. Steel Balls            | 15. Frame Head Pipe  |
| 8. Lower Outer Race       | 16. Steering Stem    |

**STEERING STEM**

The steering stem supports the handlebar and front fork shock absorbers, and turns inside the frame head pipe. Ball bearings in the upper and lower ends of the head pipe enable the steering stem to turn smoothly and easily.

The steering stem itself does not wear, but it may become bent. If it becomes bent, the steering will be stiff, and the bearings may become damaged.

The steering stem will require periodic adjustment as it becomes loose due to bearing wear. Overtightening during adjustment, however, will make the steering stiff and cause accelerated bearing wear. Lack of proper lubrication will also bring about the same results.

From overtightening or from a heavy shock to the steering stem, the bearing race surfaces may become dented. Damaged bearing races will cause the handlebar to jerk or catch when turned.

**Table 81 Bearing Ball Specifications**

	Size	Number
Upper & Lower	1/4"	19 each

**Steering stem warp**

Examine the steering stem, and replace it if it is bent.

**Bearing wear, damage**

Wipe the bearings clean of grease and dirt, and examine the races and balls. If the balls or races are worn, or if either race is dented, replace both races and all the balls for that bearing as a set.

**Bearing lubrication**

In accordance with the periodic maintenance chart (Pg. 172), and whenever the steering stem is disassembled, the steering stem bearings should be relubricated.

Wipe all the old grease off the races and balls, washing them in a high flash point solvent of some kind if necessary. Replace the bearing parts if they show wear or damage. Apply grease liberally to the upper and lower races, and stick the bearing balls in place with grease.

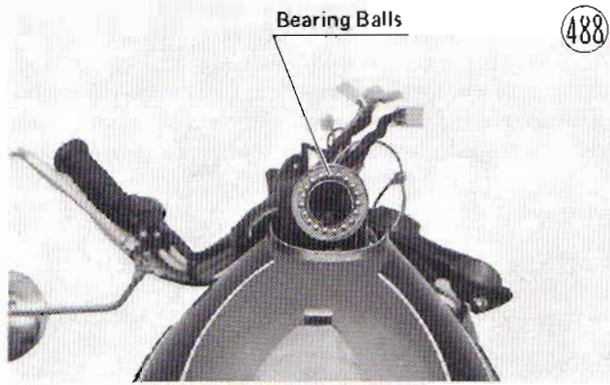

Bearing Balls

488

**FRONT FORK**

Front fork construction is shown in Fig. 490. It consists of two shock absorbers connected to the frame head pipe by the stem base and stem head bracket. It accomplishes shock absorption through spring action, air compression in the inner tube, and resistance to the flow of the oil forced into the cylinder by tube movement.

**Front Spring Force**

489

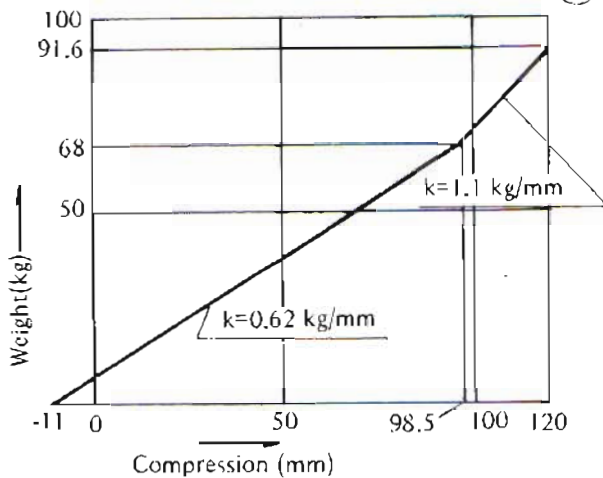

Each shock absorber is a telescopic tube including an inner tube 16, outer tube 17, cylinder 24, piston 18, collar 23, and cylinder base 25. The inner tube fits into the outer tube, altering its position in the outer tube as the tube arrangement absorbs shocks. The cylinder is fixed to the bottom of the outer tube and the piston (equipped with a piston ring 19) is secured to the top of the cylinder. The collar (coupled with a non-return valve 22), fixed in the lower end of the inner tube, forms the upper part of the lower chamber and together with the piston helps seal the upper chamber. The collar and cylinder base configuration functions to form an oil lock at the end of the compression stroke to prevent the inner tube from striking the bottom. Vertically arranged orifices (2) in the upper part of the cylinder bring about an oil lock at the end of the extension stroke to prevent the inner tube from striking the top.

Oil is prevented from leaking out by the oil seal 15, which is fitted at the upper end of the outer tube. A dust seal 13 on the outside of the tube keeps dirt and water from entering and damaging the oil seal and tube surface.

Front Fork

490

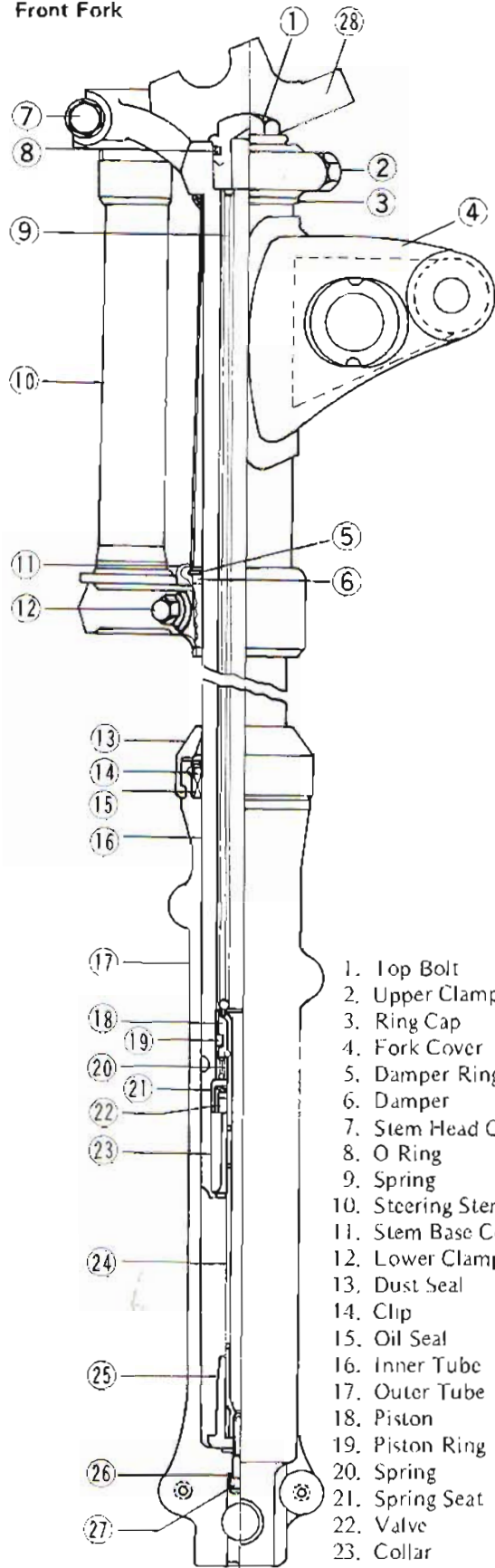

1. Top Bolt
2. Upper Clamp Bolt
3. Ring Cap
4. Fork Cover
5. Damper Ring
6. Damper
7. Stem Head Clamp Bolt
8. O Ring
9. Spring
10. Steering Stem
11. Stem Base Cover
12. Lower Clamp Bolt
13. Dust Seal
14. Clip
15. Oil Seal
16. Inner Tube
17. Outer Tube
18. Piston
19. Piston Ring
20. Spring
21. Spring Seat
22. Valve
23. Collar
24. Cylinder
25. Cylinder Base
26. Gasket
27. Allen Bolt
28. Stem Head

**Compression stroke**

Whenever a load is placed on the front fork and whenever the front wheel receives a shock, the inner tube (10) moves down inside the outer tube (11), compressing both the spring (1) and the air in the inner tube. At the same time, low pressure (suction) is created in an enlarging chamber (upper chamber) formed between the inner tube and the cylinder (8), and draws in oil from a diminishing chamber (lower chamber) formed between the outer tube and the cylinder. As the lower chamber shrinks in size with oil passing freely through the non-return valve (6) into the upper chamber, oil also passes freely through the cylinder lower orifices into the cylinder as the inner tube approaches the cylinder base (9). Near the end of the compression stroke, the clearance between the tapered-out cylinder base and the collar at the lower end of the inner tube approaches zero. The resulting resistance to the flow of oil through this small space slows the downward movement, finally forming an oil lock to finish the compression stroke.

**Extension stroke**

Following the compression stroke is the extension stroke, in which the inner tube is pushed back out by the compressed spring. As the tubes move apart, the upper chamber grows smaller, forcing the oil through the cylinder upper orifices since the oil cannot return the way it came through the non-return valve. These small holes resist the oil flow into the inner tube, damping fork extension. Near the end of the extension stroke both the cylinder spring and the arrangement of the cylinder upper orifices provide further resistance to extension. As the collar rises reducing the size of the upper chamber, one orifice is eliminated as an upper chamber outlet, which reduces the oil flow slowing extension. When the other orifice is eliminated, an oil lock forms, which finishes the extension stroke.

Either too much or too little oil in the shock absorbers will adversely affect shock damping. Too much oil or too heavy an oil makes action too stiff; too little oil or too light an oil makes the action soft, decreases damping potential, and may cause noise during fork movement.

Contaminated or deteriorated oil will also affect shock damping, and, in addition, will accelerate internal wear. The fork oil should be changed in accordance with the periodic maintenance chart (Pg. 172) or sooner if the oil appears dirty.

A bent, dented, scored, or the otherwise damaged inner tube will damage the oil seal, causing oil leakage. A badly bent inner tube may cause poor handling.

**Fork oil**

To check the fork oil level, first place a jack or stand under the engine so that the front wheel is raised off the ground. Remove the top bolt from the inner tube. Insert a rod down into the tube, and measure the distance from the top of the inner tube to the oil level. If the oil is below the correct level, add enough oil to bring it up to the proper level, taking care not to overfill.

**Compression Stroke**

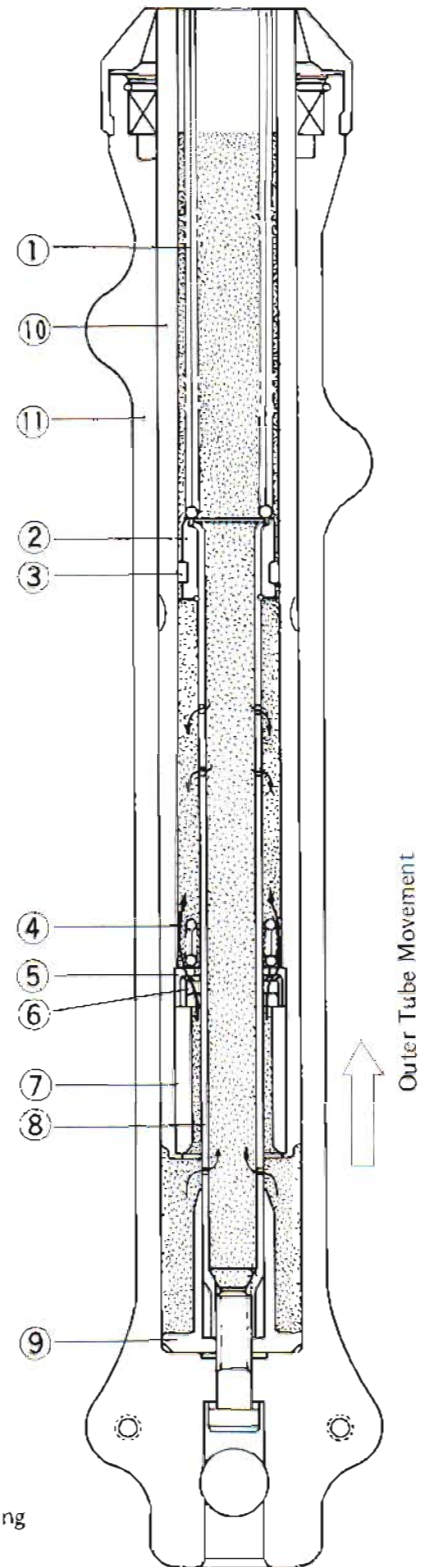

- 1. Spring
- 2. Piston
- 3. Piston Ring
- 4. Spring
- 5. Spring Seat
- 6. Valve
- 7. Collar
- 8. Cylinder
- 9. Cylinder Base
- 10. Inner tube
- 11. Outer tube

Extension Stroke

492

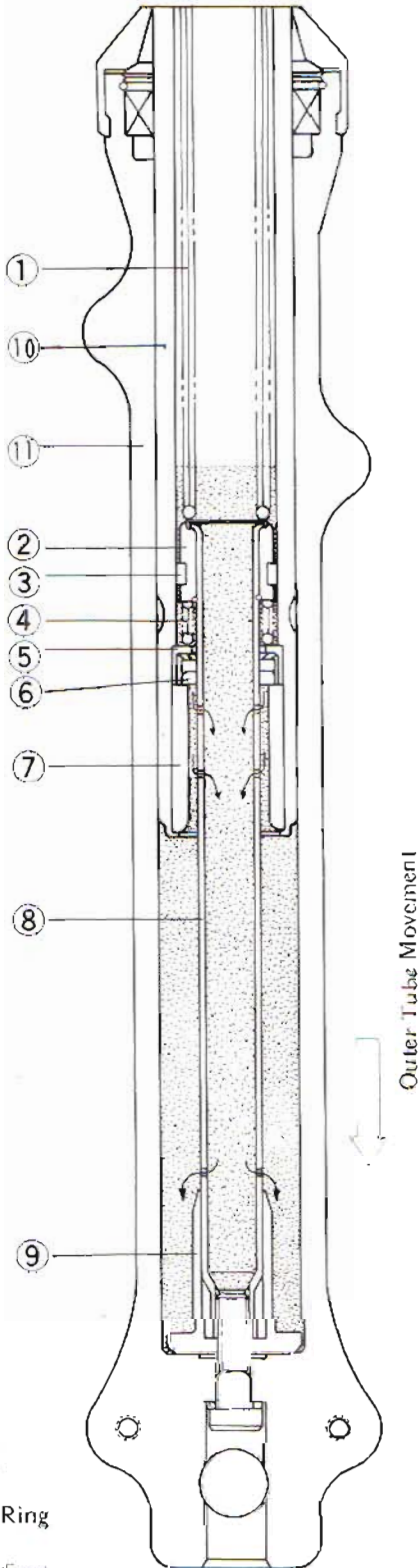

- 1. Spring
- 2. Piston
- 3. Piston Ring
- 4. Spring
- 5. Spring Seat
- 6. Valve
- 7. Collar
- 8. Cylinder
- 9. Cylinder Base
- 10. Inner tube
- 11. Outer tube



Table 82 Fork Oil

Type	Amount per side	Oil level from top of inner tube
SAE 5W/20	150~170 cc	340~360 mm

To drain out the old oil, remove the drain bolt from the lower end of the outer tube on each side. With the front wheel on the ground, push down on the handlebar a few times to pump out the oil. Replace the drain bolts, remove the top bolt from each side, and pour in the specified type and amount of oil. Then replace the top bolts, tightening them with 2.5 ~ 3.0 kg-m (18 ~ 22 ft-lbs) of torque.

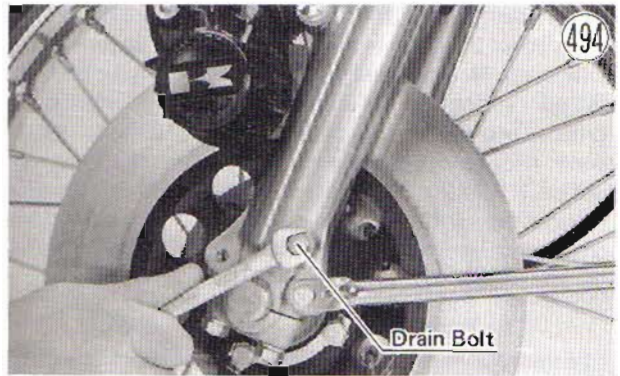

Spring tension

Since the spring becomes shorter as it weakens, check its free length to determine its condition. If the spring of either shock absorber is shorter than the service limit, it must be replaced. If the length of a replacement spring and that of the remaining spring vary greatly, the remaining spring should also be replaced in order to keep the shock absorbers balanced for motorcycle stability.

495

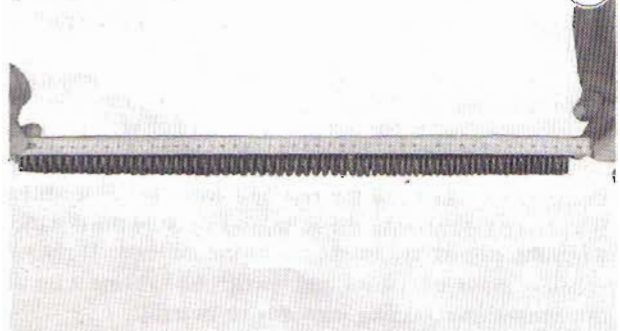

Table 83 Fork Spring Free Length

Standard	Service Limit
475 mm	465 mm

**Inner tube damage**

Visually inspect the inner tube, and repair any damage. If the damage is not repairable, replace the inner tube. Since damage to the inner tube damages the oil seal, replace the oil seal whenever the inner tube is repaired or replaced.

**REAR SHOCK ABSORBERS**

The rear shock absorbers serve to dampen shock transmitted to the frame and rider from the rear wheel. For this purpose they are connected between the frame and the rear end of the swing arm. Shock absorption is performed by the spring and by the resistance to the flow of oil inside each unit. Shock absorption is further aided by the use of rubber bushings in both the upper and lower shock absorber mountings.

Since the rear shock absorbers are sealed units which cannot be disassembled, only external checks of operation are necessary. With the shocks removed, compress each one and see that the compression stroke is smooth and that there is damping besides spring resistance to compression. When the unit is released, the spring should not suddenly snap it to full length. It should extend smoothly with notable damping. When the shock absorber is operated, there should be no oil leakage. If either shock absorber does not perform all of these operations satisfactorily, or if one unit feels weaker than the other, replace both shock absorbers as a set. If only one unit is replaced and the two are not balanced, motorcycle instability at high speeds may result.

Shock absorber spring force for the 5 different settings is shown in the graph.

Rear Spring Force

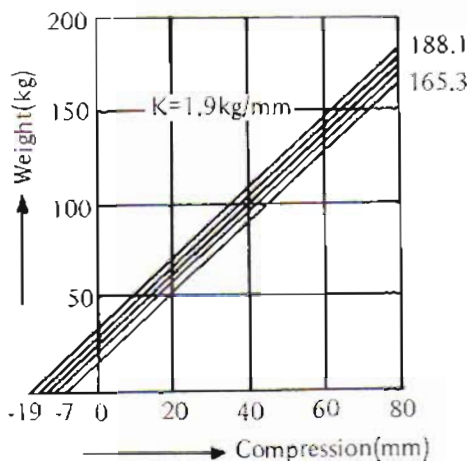

**Bushings**

Check the rubber bushings, and replace any that are worn, cracked, hardened, or otherwise damaged.

Rear Shock Absorber

497

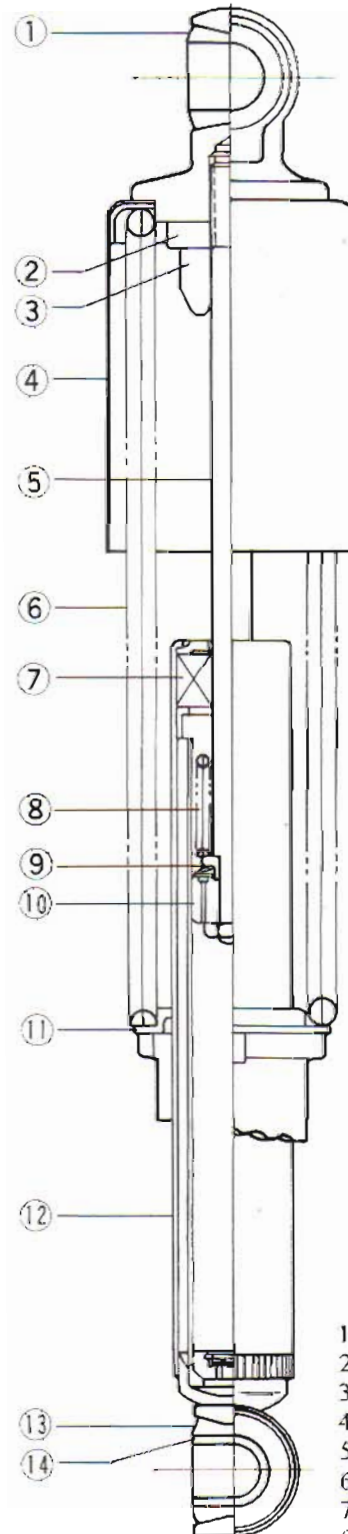

- 1. Rubber Bushing
- 2. Nut
- 3. Stopper Rubber
- 4. Cover
- 5. Piston Rod
- 6. Outer Spring
- 7. Oil Seal
- 8. Inner Spring
- 9. Check Valve
- 10. Piston
- 11. Spring Seat
- 12. Outer Shell
- 13. Rubber Bushing
- 14. Collar

496

**SWING ARM**

The swing arm is designed to work with the shock absorbers to dampen the shock to the frame from the rear wheel. The rear of the swing arm is connected to the frame by the rear shock absorbers, while the front end pivots on a shaft connected to the frame. When the rear wheel receives a shock, the swing arm, pivoting on its shaft, allows the wheel to move up and down in relation to the frame within the limits of the shock absorbers.

Wear takes place where the short sleeves and bushes rub together. If wear has progressed such that the swing arm has become loose, the motorcycle will be unstable, especially at high speeds. To minimize wear, the swing arm should be kept properly packed with grease.

A bent pivot shaft or twisted swing arm will also cause instability by throwing the rear wheel out of alignment.

*Sleeve, bush wear*

Measure the outside diameter of the sleeves at both ends with a micrometer. Replace both sleeves if the diameter of either is less than the service limit or if either shows visible damage.

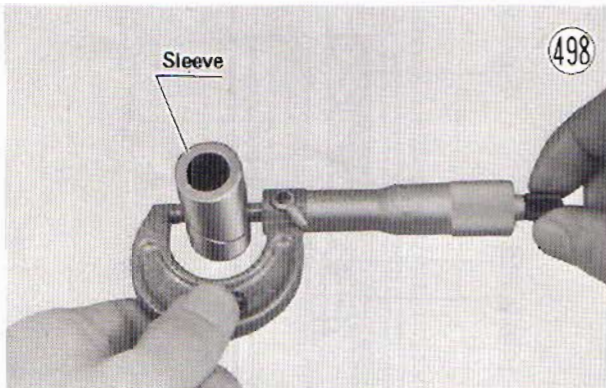

Measure the inside diameter of each bush with a cylinder gauge. Replace both bushes if the diameter of either exceeds the service limit. Also, replace both bushes if either shows visible damage.

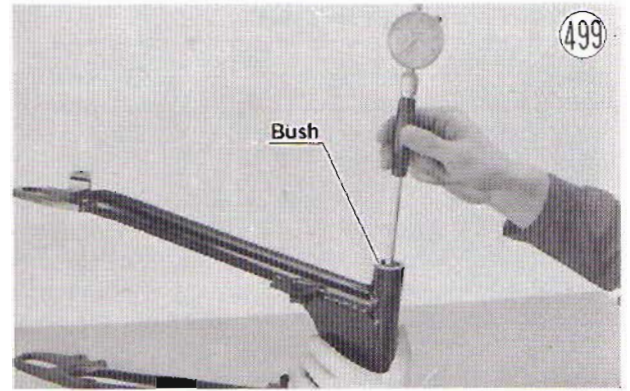
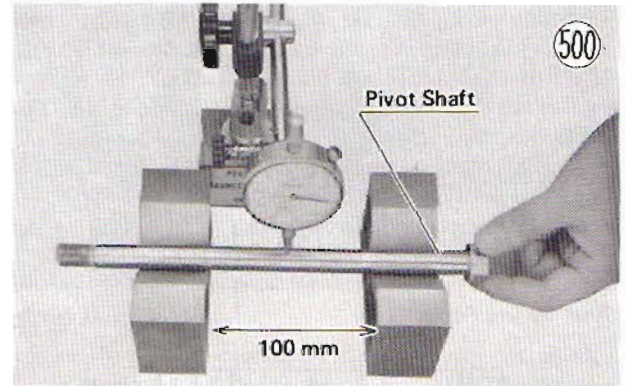

**Table 84 Swing Arm Sleeve, Bush Diameter**

	Standard	Service Limit
Sleeve outside dia.	21.979~22.000 mm	21.95 mm
Bush inside dia.	22.030~22.063 mm	22.26 mm

*Pivot shaft*

Check whether or not the pivot shaft is bent by placing it in two V blocks set 100 mm apart, setting a dial gauge to the shaft halfway between the blocks, and turning the shaft to get a variation in the dial gauge reading. If the shaft runout exceeds the service limit, straighten it. If it cannot be straightened, or if the runout exceeds 0.7 mm, replace the shaft.



**Swing Arm**

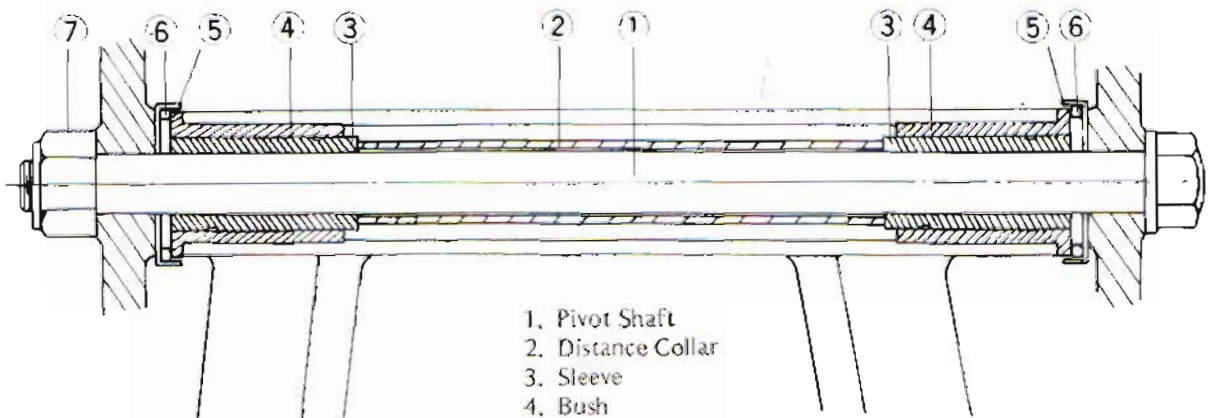

- 1. Pivot Shaft
- 2. Distance Collar
- 3. Sleeve
- 4. Bush
- 5. Cap
- 6. O Ring
- 7. Pivot Shaft Nut

Table 85 Pivot Shaft Runout/100 mm

Standard	Service Limit
under 0.1 mm	0.2 mm

**Lubrication**

There is a grease fitting on the swing arm for lubrication. Grease the swing arm with regular cup grease as a part of general lubrication (Pg. 173) with the frequency given in the periodic maintenance chart (Pg. 172). Force the grease into the fitting until it comes out at both sides of the swing arm, and wipe off any excess. If the grease does not come out, first check that the fitting is not clogged with dirt or old grease. If the fitting is clear but will still not take grease, remove the swing arm pivot shaft, sleeves and bushes, and clean out the old grease first.

**MUFFLERS**

The mufflers reduce exhaust noise and conduct the exhaust gases back away from the rider while keeping power loss to a minimum.

If there is any exhaust leakage where the mufflers connect to the cylinder head, or if the gaskets appear damaged, replace the gaskets. If either muffler is badly damaged, dented, cracked or rusted, replace it for a new one.

**Muffler**

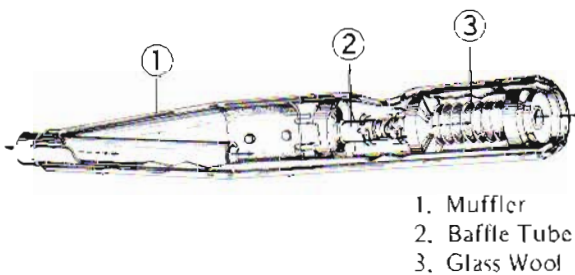

**DYNAMO**

The dynamo generates the current required by the electrical circuits. The generated current is a 3 phase alternating current (AC), which is changed to direct

**Dynamo Construction**

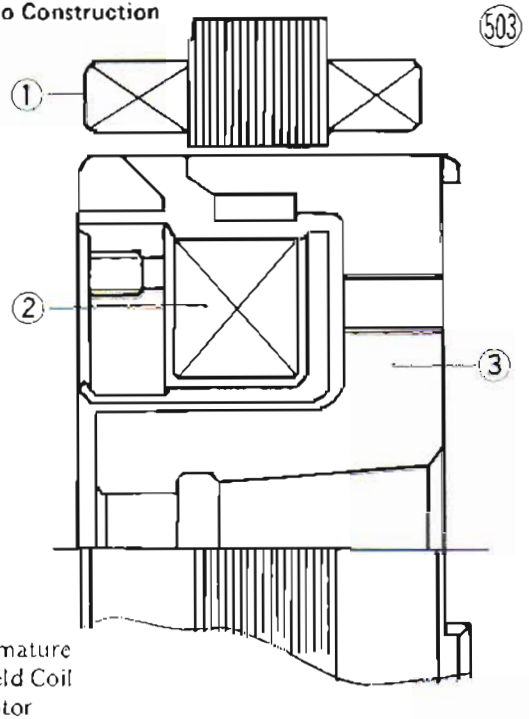

current (DC) by a rectifier and controlled by a 2 point regulator to supply an even voltage to the circuit components.

The dynamo consists of a stationary field coil and armature and a revolving rotor, all of which are separately mounted. The field coil and armature are both mounted in the dynamo cover, while the rotor is secured to the left end of the crankshaft and rotates at engine rpm.

When the ignition switch is turned on, current controlled by the regulator flows to the field coil, and the resulting magnetic field (that accompanies electron flow) is concentrated in the rotor. Then, when starting the engine, the kickstarter or starter motor turns the crankshaft, and magnetic lines of force cut through the armature windings (3) generating current. These windings are connected in a wye connection (Fig. 505) to produce a 3 phase alternating current (Fig. 506). Since the

**Dynamo Circuit**

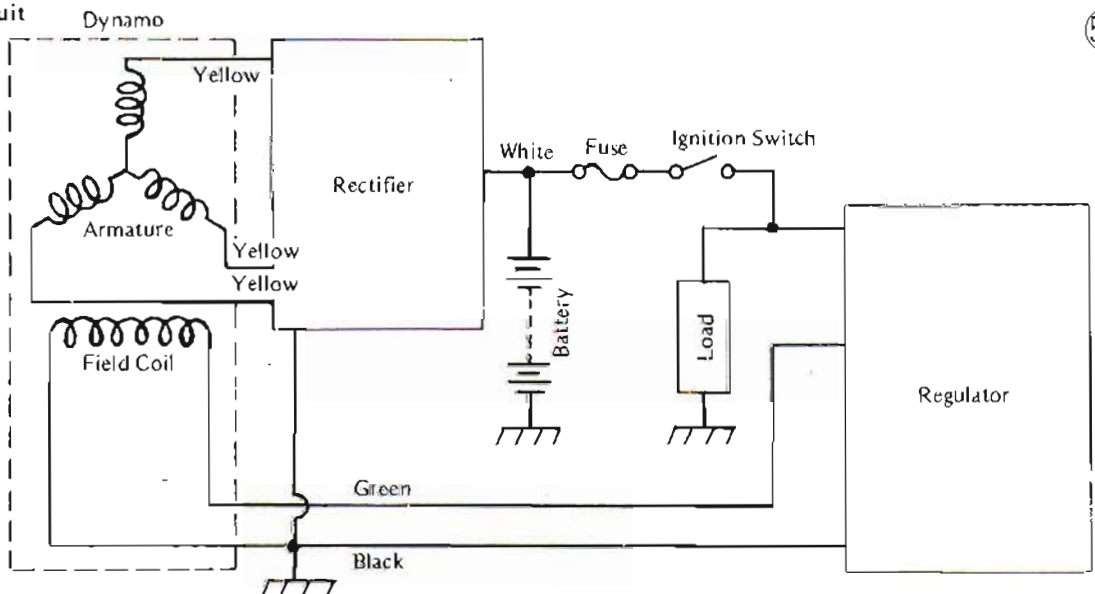

## 148 MAINTENANCE

voltages of these 3 phases overlap, there is a continuous, even supply of current for the circuit components.

### Wye Connection

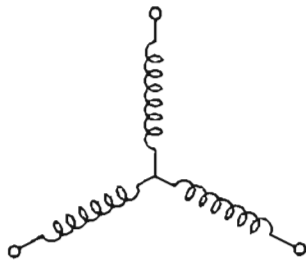

505

### Dynamo Current

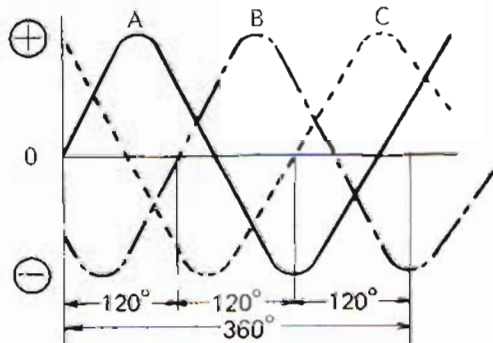

506

If the battery, rectifier, and regulator are all good but there is low voltage or insufficient charging current, the dynamo may be defective. A defective dynamo is due to either an electrical short or open in the field coil or armature. Either an electrical short or open will result in a low output or no output at all.

### Dynamo test

Before making this test, check the condition of the battery (Pg. 155) and rectifier (Pg. 150). If the battery voltage is less than 12 volts, charge the battery. Both the output voltage and output amperage is checked.

- Remove the left side cover and the headlight unit (Pg. 87), and disconnect the 6P connector, which is on the left side of the motorcycle, and the 9P connector,

which is in the headlight housing. This removes the load from the dynamo.

- Disconnect the rectifier white lead from the battery + lead.
- Set a multimeter to the 30 VDC range, and connect its + lead to the rectifier white lead and its - lead to chassis ground.



507

- Remove the right side cover, and disconnect the regulator green and brown leads from the regulator terminals marked F and I respectively. Connect the green and the brown leads together electrically.



508

**CAUTION:** When connecting the green and the brown leads, be certain that the connection does not get shorted to chassis ground. Also, do not leave these leads connected any longer than necessary; disconnect them after finishing the test.

### Dynamo Voltage Test

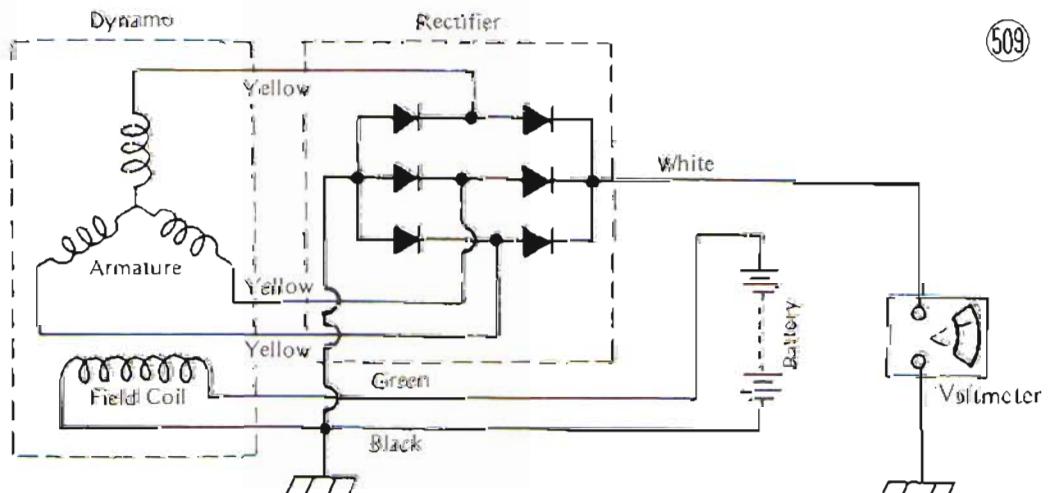

509

- Start the engine, run it at idling speed (1,100~1,300 rpm), and note the meter reading. The reading should be 14 VDC or more. A lower reading indicates the dynamo is defective.

**CAUTION:** When or after starting the engine, DO NOT allow the engine to run at a higher rpm (not above 2,000 rpm) in order not to damage the rectifier and other electrical components.

- Stop the engine, and connect a variable resistor (1Ω 200W) in series with the rectifier, one lead to the rectifier white lead and the other lead to chassis ground.
- Set the resistor at its highest resistance, and start the engine. While adjusting the resistor to keep the voltage at 14.5 VDC, gradually raise the engine speed up to 5,000 rpm.

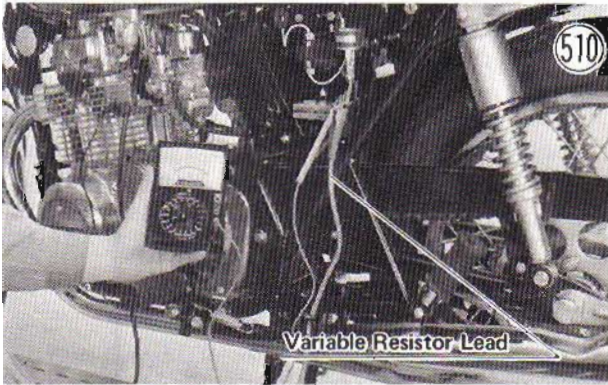

Dynamo Amperage Test 1

- Stop the engine, disconnect the multimeter lead which is connected to chassis ground, and disconnect the variable resistor lead which is connected to the rectifier white lead.
- Set the multimeter to the 30 ADC range, and connect the meter — lead to the variable resistor. This puts the rectifier, multimeter, and variable resistor in series.

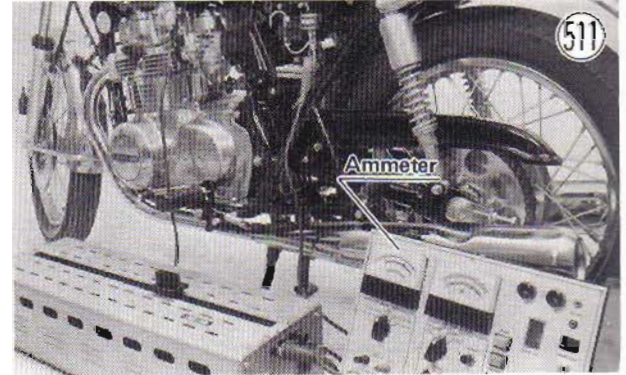

**CAUTION:** Make sure that all connections are firm. A loose connection allows the generator output voltage to increase instantly.

- Start the engine, run it at 5,000 rpm, and note the reading. The reading should be more than 13 ADC. A lower reading indicates that the dynamo is defective.
- Stop the engine, and disconnect the green and the brown leads.

If the dynamo was found to be defective, carry out the following checks to determine which part is defective.

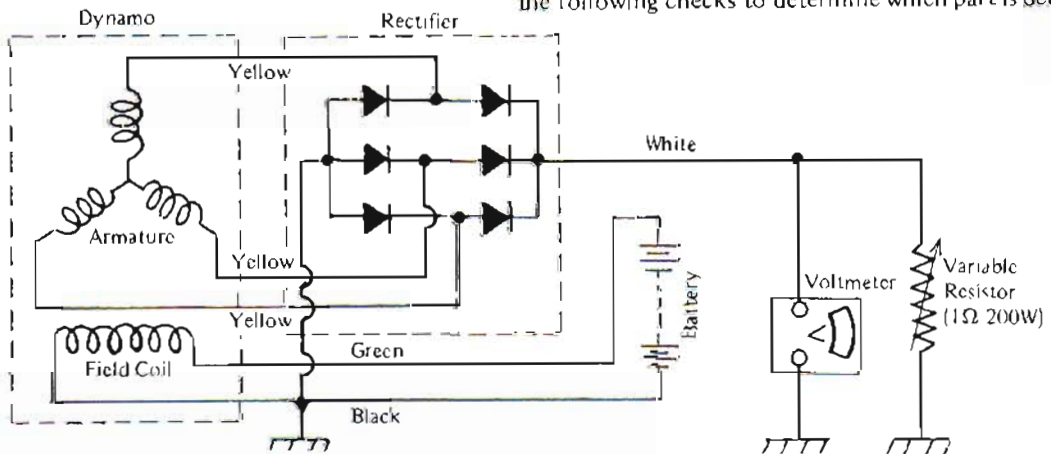

512

Dynamo Amperage Test 2

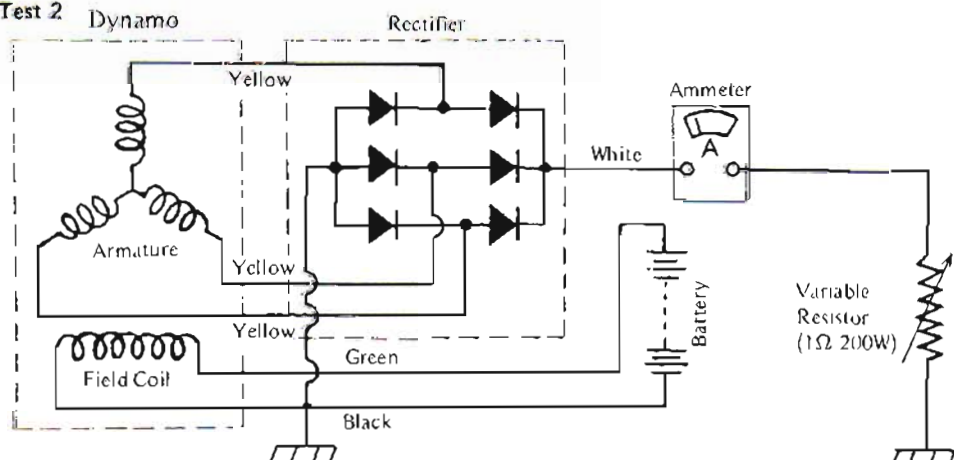

513

## 150 MAINTENANCE

- Disconnect the white plug on the left hand side below the regulator.
- Set the multimeter to the R x 1 range, and measure for continuity between each of the three armature yellow leads (3 measurements). The readings should be 0.4 ~ 0.6 ohms. If there is resistance or no meter reading (infinity) for any two armature leads, the armature has an open and must be replaced.



- Using the highest resistance range of the multimeter, measure the resistance between each of the three armature leads and chassis ground. There should be no meter reading. Any meter reading indicates a short, necessitating armature replacement.
- Disconnect the white plug on the right hand side below the regulator.
- Using the R x 1 range, measure the resistance between the field coil green lead and black lead. The resistance should be about 4.8 Ω. Less than this reading indicates a short in the coil, and a higher reading or no reading at all indicates an open. If the field coil is found to be open or shorted, replace the field coil for a new one.

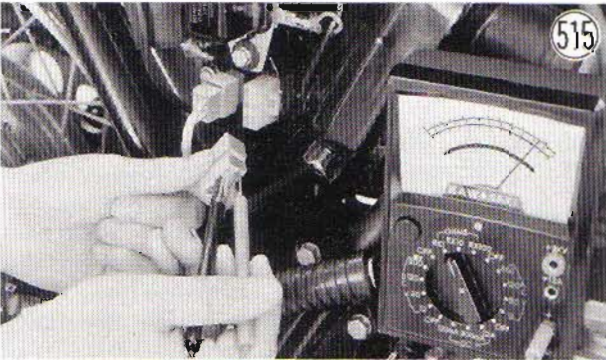

Rectifier Circuit

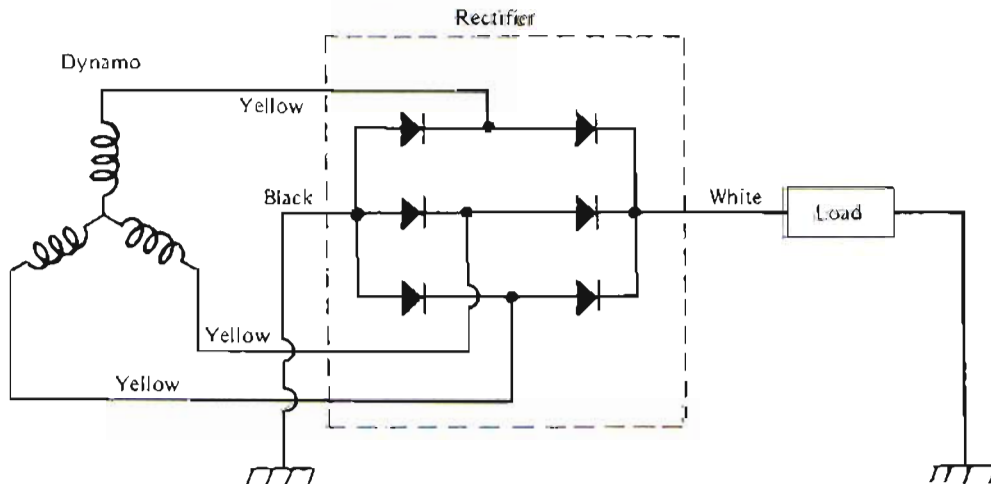

## RECTIFIER

The rectifier is used to change the alternating current (AC) from the dynamo to direct current (DC) for the battery charging, ignition, lighting, and other circuits. It contains six silicon diodes, two to rectify (change to DC) each of the three phases of the dynamo output. The diodes are connected in a bridge circuit arrangement for efficient, full-wave rectification.

The reason that a diode only permits direct current to flow in the part of the circuit in which it is connected is that a diode conducts appreciable current only in one direction. The current of electrons flows appreciably only from the - to the + side of the diode. However, a defective diode will conduct in both directions (a short) or not conduct at all (an open). If any of the diodes is shorted or open, the voltage from the rectifier will be below normal, and the battery may not charge adequately.

Diode

516

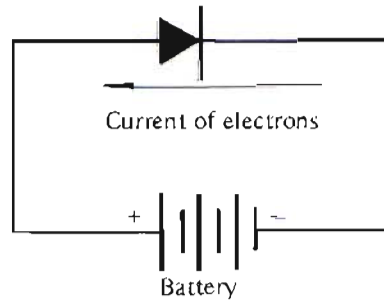

### Inspection

- With the engine off, remove the left side cover, disconnect the rectifier white lead from the battery + side, and disconnect the rectifier black lead.
- Remove the right side cover, and disconnect the white plug on the left hand side below the regulator.
- Using the R x 10 or R x 100 ohmmeter range, check the resistance in both directions between the white lead and each yellow lead, and between the black lead and each yellow lead. There is a total of 12 measurements. The resistance should be low in one direction and more than ten times as much in the other direction. If any

517

two leads are low or high in both directions, the rectifier is defective and must be replaced.



**NOTE:** The actual meter reading varies with the meter used and the individual rectifier, but, generally speaking, the lower reading should be within  $\frac{1}{3}$  scale of zero ohms.  
**CAUTION:** Be careful not to strike, scratch, or in any other way damage the rectifier. Such damage may cause the rectifier to short.

**REGULATOR**

When the field coil current is constant, the dynamo output voltage increases with an increase in engine rpm.

Field Coil Current, Dynamo Output Voltage/Engine rpm

(519)

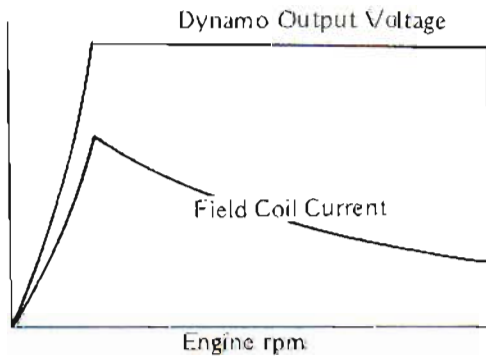

**Regulator Operation at Low Engine Speed**

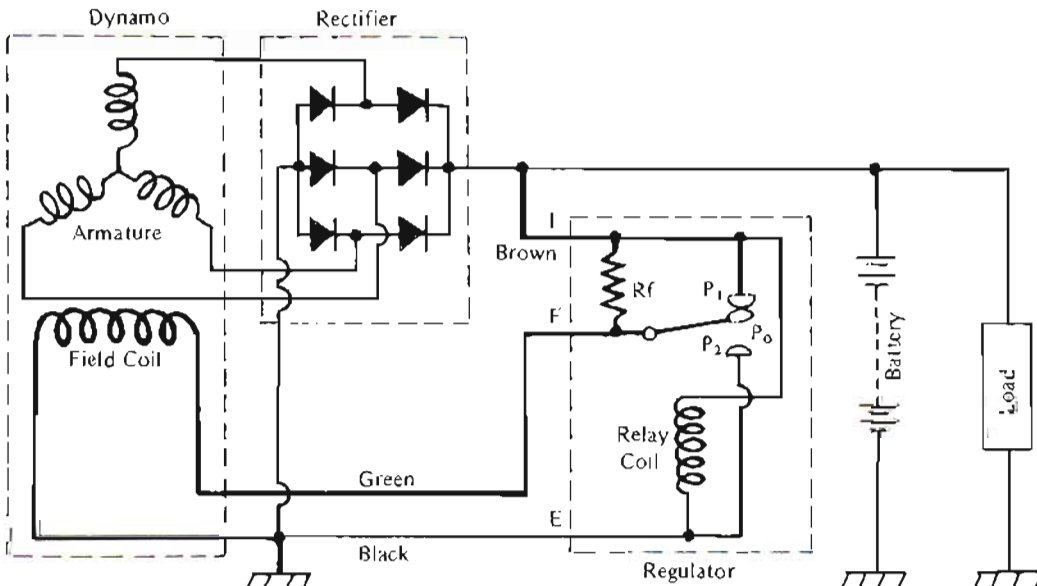

However, the voltage will become excessive at high engine rpm, burning out the lights and overcharging the battery unless the field current is reduced at higher rpm. The regulator is included in the circuit to reduce the field coil current at higher rpm, keeping the voltage between 14 ~ 15 V for all electrical equipment as shown in Fig. 519.

The regulator includes the armature, relay coil, resistance ( $R_f$ ), and three contact points ( $P_1$ ,  $P_0$ , &  $P_2$ ). Resistance  $R_f$  is in series with the field coil, while the relay coil is connected to chassis ground. Point  $P_0$  at the end of the armature is the movable contact point, which may be in contact with point  $P_1$ , in contact with no point, or in contact with point  $P_2$ .

At low rpm the dynamo output voltage magnetizes the relay coil only slightly, and point  $P_0$  is held against point  $P_1$  by spring force. At this time the field coil current,  $I_f$ , flows through chassis ground → field coil → terminal F → points  $P_0$  &  $P_1$  → terminal I. The regulator circuit here has only negligible resistance to current  $I_f$ .

At moderate rpm the dynamo output voltage magnetizes the relay coil enough that it pulls point  $P_0$  from  $P_1$ . At this time current  $I_f$  flows through chassis ground → field coil → terminal F → resistance  $R_f$  → terminal I.

**Regulator Construction**

(520)

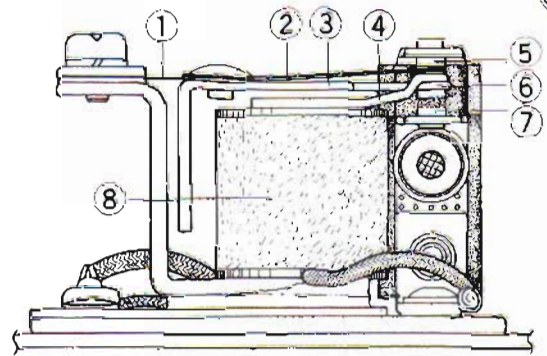

1. Spring 2. Spring 3. Armature 4. Adjuster Arm  
 5. Point  $P_1$  6. Point  $P_0$  7. Point  $P_2$  8. Relay Coil

(521)

Regulator Operation at Moderate Engine Speed

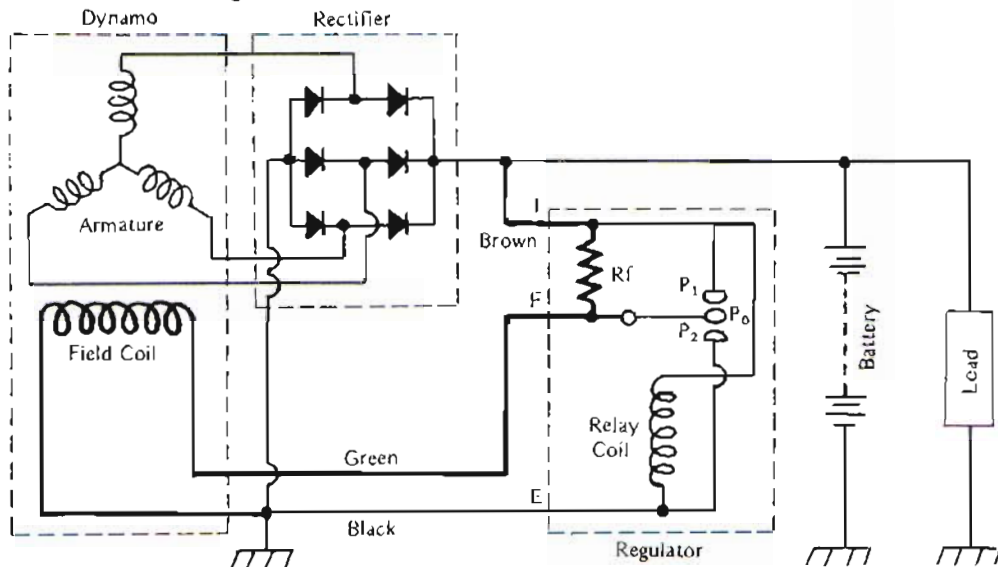

522

Regulator Operation at High Engine Speed

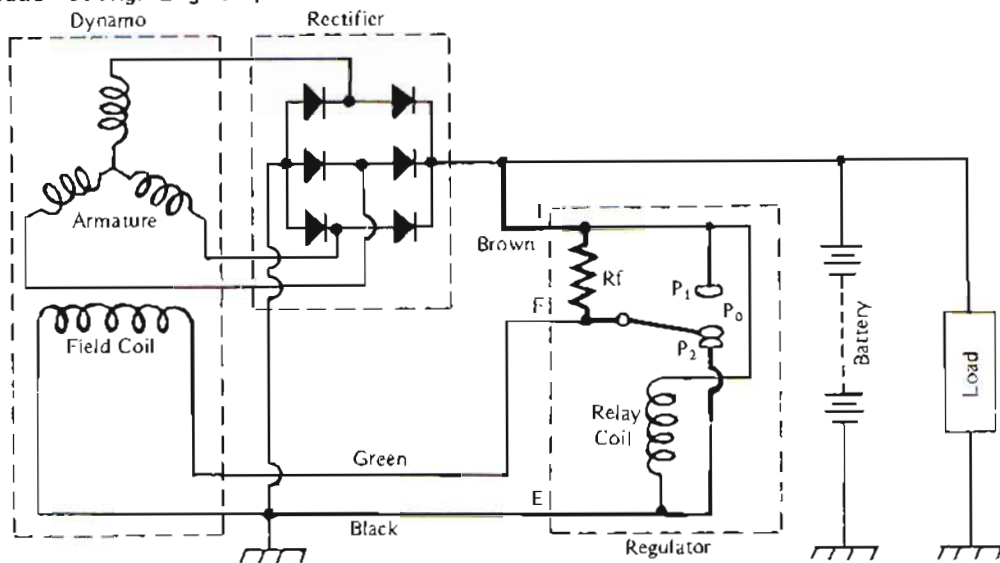

523

The regulator circuit now provides resistance  $R_f$  for current  $I_f$ , reducing current  $I_f$ . This reduces the dynamo output voltage from what it would be otherwise, keeping it still between 14~15 V.

At high rpm the dynamo output voltage magnetizes the relay coil sufficiently that it pulls point  $P_0$  in contact with point  $P_2$ . At this time no current flows to the field coil, and the dynamo output depends on residual magnetism in the rotor. Then, as the output voltage drops, the relay coil loses its magnetism such that point  $P_0$  separates from point  $P_2$ , and current again flows to the field coil.

Regulator testing

If the battery continually discharges or if it overcharges, the regulator may be defective. Symptoms of excessive voltage are: (a) distilled water must be added often to all battery cells and (b) lights burn out when running at high rpm.

Check the battery before making the following test; charge the battery if it has less than 12 V. If the battery is defective or discharged, the regulator will not function properly.

Regulator Controlled Dynamo Output Voltage

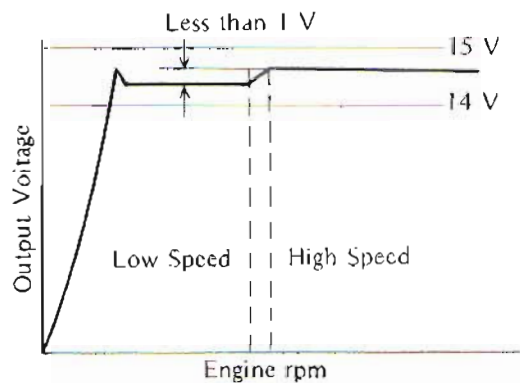

524

- Remove the left side cover and headlight unit (Pg. 87 ), and disconnect the 6P connector which is on the left side of the motorcycle and the 9P connector which is in the headlight housing. This removes the load from the dynamo.

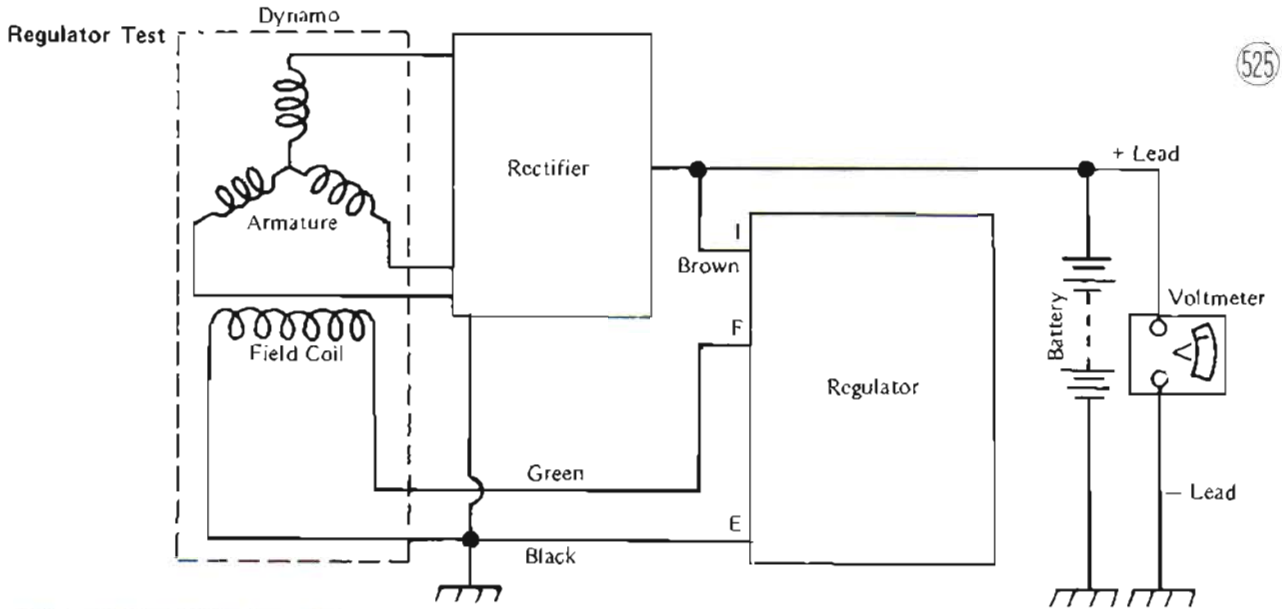

●Set a multimeter to the 30 VDC range, and connect the + meter lead to the battery + terminal and the - meter lead to the battery - terminal.

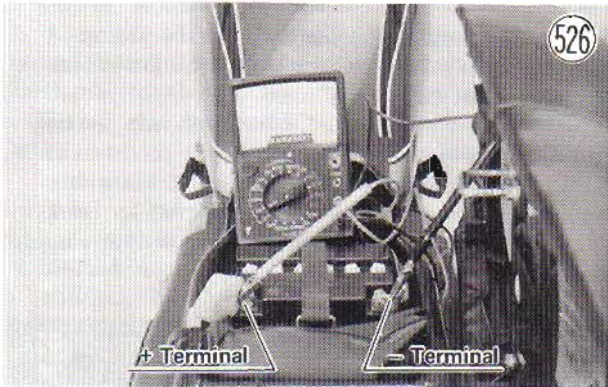

- Start the engine, hold the speed at 1,600 rpm, and note the meter reading. The reading should be between 14 ~ 15 V.
- Gradually increase engine speed (do not decrease it at any point), and check the meter reading when the engine speed has reached 4,000 rpm. The reading should be between 14 ~ 15 V.

**NOTE:** If in the above test the engine speed is decreased before the meter is read at 1,600 rpm or 4,000 rpm, return the engine rpm to idling and then again gradually increase the speed to 1,600 rpm or 4,000 rpm. Due to hysteresis, there is a difference in the voltage depending on whether the engine speed is increasing or decreasing.

If the voltage was between 14 ~ 15 V in both checks, the regulator is working satisfactorily. However, if the voltage was not 14 ~ 15 V in either one of the tests, carry out the following steps:

- NOTE:** The following steps are necessary only if regulator operation is faulty. Do not otherwise open the regulator cover. If the motorcycle is still under warranty, replace a faulty regulator; do not attempt to open or adjust it.
- Remove the right side cover, and disconnect the regulator leads, black, green, and brown, from the regulator terminals marked E, F, and I respectively.
  - Remove the regulator cover.
  - Set the multimeter to the R $\times$ 1 or R $\times$ 10 range, and measure the resistance in accordance with Table 86.



- If the points are fouled, clean them with clean paper or cloth, using an oil free solvent if necessary. To

Table 86 Regulator Resistance

Terminal	Point P <sub>0</sub>	Resistance	Remarks
F-I	Position 1	0 $\Omega$	If more than 0 $\Omega$ , points P <sub>0</sub> & P <sub>1</sub> are dirty or fouled.
	Position 2	about 9 $\Omega$	If no reading, resistor R <sub>f</sub> is open. If no resistance, there is a short.
F-E	Position 1	about 100 $\Omega$	If no reading, the relay coil is open. If no resistance, there is a short.
	Position 2	0 $\Omega$	If more than 0 $\Omega$ , points P <sub>0</sub> & P <sub>2</sub> are dirty or fouled.

Position 1 Points P<sub>0</sub> & P<sub>1</sub> are in contact by spring force.

Position 2 Points P<sub>0</sub> & P<sub>2</sub> are in contact by pressing on the armature with a finger.

## 154 MAINTENANCE

repair light damage, use emery cloth. If the points cannot be repaired so that there will be zero ohms resistance across them, replace the regulator for a new one. Also, if the resistance  $R_f$ , relay coil, or any other internal part is defective, replace the regulator for a new one.

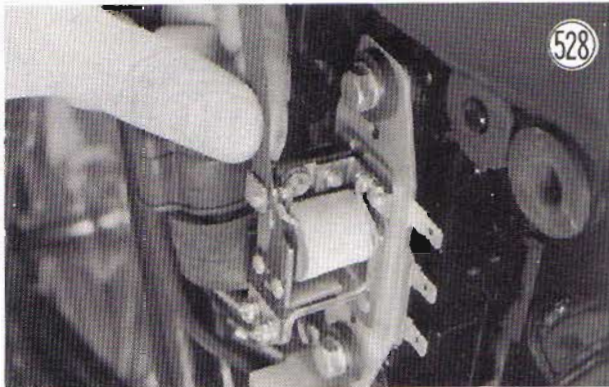

- Press down the armature, and inspect the armature gap with a thickness gauge. The gap should be 0.3 mm or more. If it is not, correct it by bending the holder for point  $P_2$ .

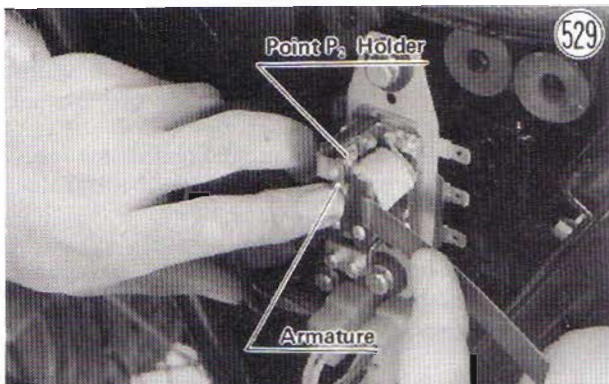

- Inspect the gap between points  $P_2$  and  $P_0$  with a thickness gauge. The gap should be 0.30~0.45 mm. If the gap is incorrect, adjust it by bending the holder for point  $P_1$ .

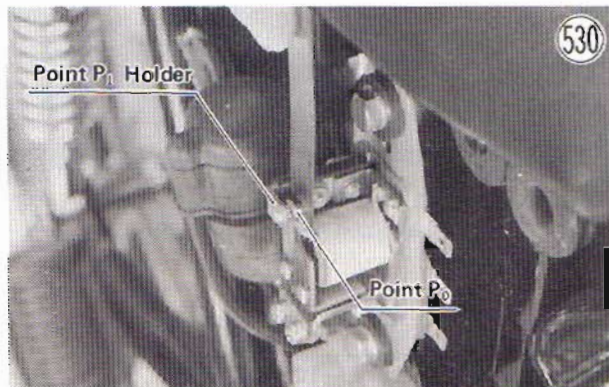

- Replace the regulator cover, and reconnect the leads (3) which were disconnected.
- Set the multimeter to the 30 VDC range, and connect the meter + lead to the battery + terminal and the meter - lead to the battery - terminal (Fig. 526).

- Start the engine, and note the voltage at various engine speeds.
- Turn off the ignition switch to stop the engine.
- If the voltage was abnormal, either too high or too low, adjust the regulator by bending the adjuster arm. Bending the arm up increases voltage, and bending the arm down decreases the voltage.

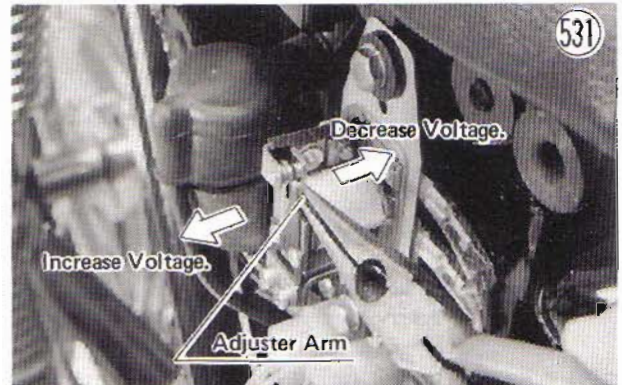

- Start the engine, and read the voltage with the engine below 2,000 rpm. The reading should be 14~15 V.
- Turn off the ignition switch to stop the engine.
- If the voltage was too low, bend the adjuster arm up; if the voltage was too high, bend the adjuster arm down.
- Start the engine, and read the voltage with the engine at 4,000 rpm. The reading should be 14~15 V.
- Turn off the ignition switch to stop the engine.
- If the voltage was too low, bend the holder for point  $P_2$  down; if the voltage was too high, bend the holder for point  $P_2$  up.

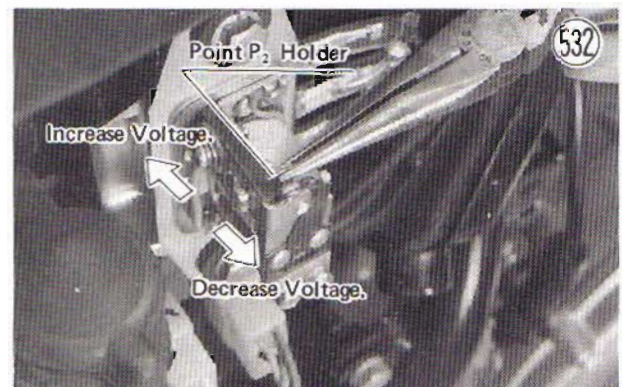

- Replace the regulator cover, and again check the voltage with the engine below 2,000 rpm and at 4,000 rpm. This recheck is necessary because the inner magnetic field is influenced by the metal cover, possibly changing regulator operation.
- If the voltage is still not correct, continue adjusting the regulator until the voltage is between 14~15 V.

## BATTERY

The battery supplies the current to the starter motor and serves as a back-up source of power to operate the electrical equipment whenever the engine is turning over too slowly for the dynamo to supply sufficient power.

With proper care, the battery can be expected to last a few years, but it may be completely ruined long before that if it is mistreated. Following a few simple rules will greatly extend the life of the battery.

1. When the level of the electrolyte in the battery is low, add only distilled water to each cell until the level is at the upper level line marked on the outside of the battery. Ordinary tap water is not a substitute for distilled water and will shorten the life of the battery. Distilled water comes in a sealed, non-metallic container; any other water is not distilled water.
2. Never add sulphuric acid solution to the battery. This will make the electrolyte solution too strong and will ruin the battery within a very short time.
3. Avoid quick-charging the battery. A quick-charge will damage the battery plates.
4. Never let a good battery stand for more than 30 days without giving it a supplemental charge, and never let a discharged battery stand without charging it. If a battery stands for any length of time, it slowly self-discharges. (Once it is discharged, the plates sulphate (turn white), and the battery will no longer take a charge.
5. Keep the battery well charged during cold weather so that the electrolyte does not freeze and crack open the battery. The more discharged the battery becomes, the more easily it freezes.
6. Always keep the battery vent hose free of obstruction, and make sure it does not get pinched or crimped shut. If battery gases cannot escape from this hose, they will explode the battery.
7. Always remove the battery from the motorcycle for charging it. If the battery is charged while still installed, battery electrolyte may spill and corrode the frame or other parts of the motorcycle.
8. **DON'T INSTALL THE BATTERY BACKWARDS.** The negative side is grounded.

**Electrolyte**

The electrolyte is dilute sulphuric acid. The standard specific gravity of the electrolyte used in warm climates in a fully charged battery is 1.260 at 20°C (68°F). In particularly cold regions a solution with a standard specific gravity of 1.280 is used. The water in this solution changes to a gaseous mixture due to chemical action in the battery and escapes, which concentrates the acid in a charged battery. Consequently, when the level of the electrolyte becomes low, only distilled water should be added. If sulphuric acid is added, the solution will become too strong for proper chemical action and will damage the plates. Metal from the damaged plates collects in the bottom of the battery. This sediment will eventually cause an internal short circuit.

The specific gravity of the electrolyte is measured with a hydrometer and is the most accurate indication of the condition of the battery. When using the hydrometer, read the electrolyte level at the bottom of the meniscus (curved surface of the fluid). Fig. 534 shows the relationship between the specific gravity of the solution at 20°C (68°F) and the percentage of battery charge. Since specific gravity varies with temperature, and since the temperature of the solution being checked is likely to be other than 20°C (68°F), the formula

**Hydrometer**

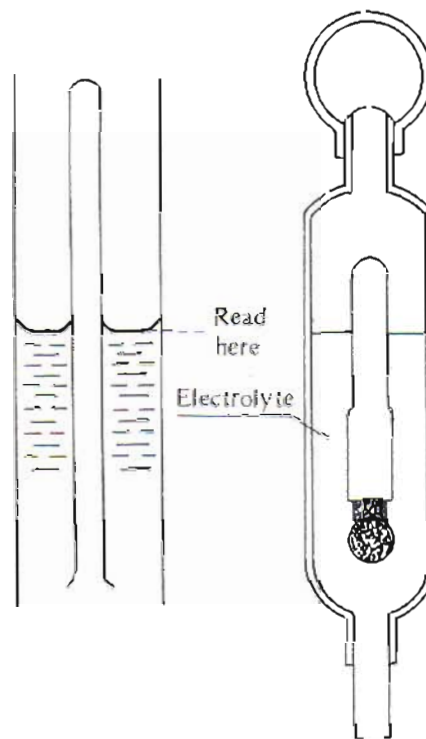

given below should be used to compute what the specific gravity would be if the temperature were 20°C (68°F). When the temperature goes up, the specific gravity goes down, and vice versa.

Celcius

$$S_{20} = S_t + [0.0007 (t - 20)]$$

Fahrenheit

$$S_{68} = S_t + [0.0004 (t - 68)]$$

$S_t$  = specific gravity at the present temperature

$S_{20}$  = specific gravity at 20°C

$S_{68}$  = specific gravity at 68°F

$t$  = present temperature of solution

Generally speaking, a battery should be charged if a specific gravity reading shows it to be discharged to 50% or less of full charge.

**Specific Gravity/Battery Charge Relationship**

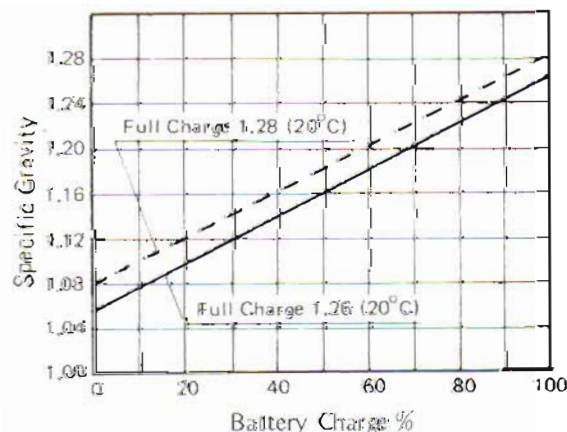

*Initial charge*

New batteries for Kawasaki motorcycles are dry charged and can be used directly after adding the electrolyte. However, the effect of the dry charge deteriorates somewhat during storage, especially if any air has entered the battery from imperfect sealing. Therefore, it is best to give the battery an initial charge before using it in order to ensure long battery life.

**CAUTION:** Because the battery gives off an explosive gas mixture of hydrogen and oxygen, keep any sparks or open flame away from the battery during charging.

- Pour a 1.260 (specific gravity at 20°C or 68°F) sulphuric acid solution into each cell of the battery up to the upper line.
- Let the battery stand for 30 minutes, adding more acid if the level drops during this time.

**NOTES:** 1. If the temperature of the solution is over 30°C (85°F), cool the solution before pouring it into the battery.

2. After pouring the acid into the battery, start charging the battery within 12 hours.

- Leaving the caps off the cells, connect the battery to a charger, set the charging rate at 1/10 the battery capacity, and charge it for 10 hours. For example, if the battery is rated at 12 AH, the charging rate would be 1.2 ampere. If a constant voltage charger is used, the voltage must be adjusted periodically to keep the current at a constant value.

**CAUTION:** If the temperature of the electrolyte rises above 45°C (115°F) during charging, reduce the charging rate to bring down the temperature, and increase the charging time proportionately.

- After charging, check the electrolyte level in each cell. If the level has dropped, add distilled water to bring it back to the upper line.
- Check the results of charging by measuring the specific gravity of each cell and by measuring battery voltage. Battery voltage of a 12 volt battery directly after the completion of charging should be 15 to 16 volts.

*Ordinary charge*

**CAUTION:** Because the battery gives off an explosive gas mixture of hydrogen and oxygen, keep any sparks or open flame away from the battery during charging.

- Clean off the battery using a solution of baking soda and water. Make especially sure that the terminals are clean.
- If the electrolyte level is low in any cell, fill to over

the lower line but not up to the upper line since the level rises during charging. Figure the charging rate to be between 1/10 and 3/10 of battery capacity. For example, the maximum charging rate for a 12 AH battery would be 3/10 x 12 which equals 3.6 amperes.

- Measure the specific gravity of the electrolyte, and use the graph, Fig. 534, to determine the percentage of discharge. Multiply the capacity of the battery by the percentage of discharge to find the amount of discharge in ampere-hours. Use this figure in the formula below to compute charging time.

$$\text{charging time (hours)} = \frac{\text{amount of discharge (AH)}}{\text{charging current (A)}} \times 1.2 \sim 1.5$$

- Remove the caps from all the cells, and begin charging the battery at the rate just calculated. If a constant voltage charger is used, the voltage will have to be adjusted periodically to maintain charging current at a constant value.

**CAUTION:** If the temperature of the electrolyte rises above 45°C (115°F) during charging, reduce the charging rate to bring down the temperature, and increase charging time proportionately.

- After charging, check the electrolyte level in each cell. If the level has dropped, add distilled water to bring it back up to the upper line.
- Check charging results by measuring the specific gravity of each cell and by measuring battery voltage. Battery voltage of a 12 volt battery directly after the completion of charging should be 15 to 16 volts. If the voltage is lower than this, the battery is not completely charged or can no longer take a full charge.

*Test charging*

When the battery is suspected of being defective, first inspect the points noted in the chart below. The battery can be tested by charging it by the ordinary charge. If it will take a charge so that the voltage and specific gravity come up to normal, it may be considered good except in the following cases:

- ★ If the voltage suddenly jumps to over 13 volts just after the start of charging, the plates are probably sulphated. A good battery will rise to 12 volts immediately and then gradually go up to 12.5 ~ 13 volts in about 30 to 60 minutes after charging is started.
- ★ If one cell produces no gas or has a very low specific gravity, it is probably shorted.
- ★ If there does not appear to be enough sediment to

Table 87 Battery Troubleshooting Guide

	Good Battery	Suspect Battery	Action
Plates	(+) chocolate color (-) gray	white (sulphated); + plates broken or corroded	Replace
Sediment	none, or small amount	sediment up to plates, causing short	Replace
Voltage	above 12 volts	below 12 volts	Test charge
Electrolyte level	above plates	below top of plates	Fill and test charge
Specific gravity	above 1.200 in all cells; no two cells more than 0.020 different.	below 1.100, or difference of more than 0.020 between two cells	test charge

short the plates, but one cell has a low specific gravity after the battery is fully charged, the trouble may be just that there is insufficient acid in that cell. In this case only, sulphuric acid solution may be added to correct the specific gravity.

★ If a fully charged battery not in use loses its charge after 2 to 7 days, or if the specific gravity drops markedly, the battery is defective. The self-discharge rate of a good battery is only about 1% per day.

**IGNITION SYSTEM**

The ignition system, shown in Fig. 535, consists of the battery, contact breaker, condenser, ignition coil, and two spark plugs (Pg. 159). The battery supplies the current for the primary circuit, which includes the contact breaker points, condenser, and the primary winding of the ignition coil. When the points suddenly open with the ignition switch turned on, a surge of electrons is produced in the secondary circuit, which includes the ignition coil secondary winding and the two spark plugs. For this system to function properly, all ignition parts must be in good order, the ignition timing correctly set, the ignition and engine stop switches not shorted, and all wiring in good condition (no shorts or breaks, and no loose or tarnished connections).

With the ignition switch on and the points closed, current flows in the primary circuit, including the ignition coil primary winding where the magnetic field (which accompanies electron flow) is concentrated (due to the winding). When the points open, this circuit is broken stopping the electron flow and collapsing the magnetic field. As this field collapses, magnetic flux cuts through the secondary winding inducing current in the winding. The voltage of this current, dependent on the number of turns in the secondary winding and the speed of the drop in the primary winding voltage, is much greater than the voltage in the primary winding. It is this high voltage that causes a spark to jump across the spark plug electrodes. Since a greater ratio of secondary winding turns over primary winding turns and a sharper drop of primary winding voltage increase the secondary winding voltage that is produced, a certain ratio of turns in the ignition coil has been chosen and a certain voltage drop sharpness (determined by condenser and breaker point performance) has been designed in the ignition system such that a spark of sufficient but not excessive strength will be produced.

Ordinarily in a 4-stroke engine, a spark jumps across the spark plug electrodes only every other time that the piston for that spark plug rises (once every 720°

of crankshaft rotation) because between each compression stroke, in which a fuel/air mixture ready for combustion is in the cylinder, there is an exhaust stroke, in which the piston rises only to push out the burned gases. However, even if a spark does jump across the electrodes during the exhaust stroke, there is no effect since there is no compression and no fuel to burn. Therefore, to eliminate any need for a distributor (thus simplifying the system, making it more reliable), the system is constructed so that both spark plugs fire every time both pistons rise (once every 360° of crankshaft rotation) although one piston is on the compression stroke and the other on the exhaust stroke.

The contact breaker consists of one fixed and one movable contact point. The movable point is pivoted, and the heel on one end is held against the cam surface on the timing advancer by a single leaf spring. As the crankshaft rotates, the heel rides on the cam surface, and, as the crankshaft reaches the position where ignition takes place, the high spot on the cam surface pushes out on the heel, which opens the points. As the heel wears down, the point gap narrows, affecting ignition timing. Consequently, the ignition timing must be periodically adjusted to compensate for heel wear.

The condenser is connected in parallel across the contact breaker points and serves to prevent current from arcing across the points as they open. Arcing across the points would reduce the sharpness of the voltage drop in the primary winding, thus weakening the spark plug spark, and also damage the surface of the points. When the points are first opening, the condenser absorbs a certain amount of current, giving the points time to open far enough apart to where current will not arc across. However, if the condenser shorts, the current will simply flow through the condenser whenever the points open. When the condenser is otherwise defective, the current will not be prevented from arcing across the points at the time of ignition, resulting in poor spark plug performance and burned and pitted points.

Because the two spark plugs are connected in series, the current through one spark plug must go also through the other. Consequently, if a spark will not jump across the electrodes on one spark plug (due to dirty electrodes, faulty plug lead, etc.), no spark will jump across the electrodes on the other plug as well.

*Contact breaker inspection*

When the points become dirty, pitted, or burned, or if the spring weakens, the points will not make the

Ignition Circuit

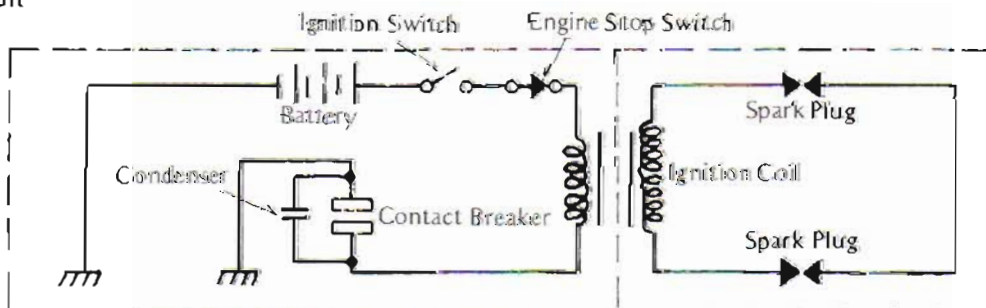

## 158 MAINTENANCE

contact necessary to produce a good spark, resulting in unstable idling, misfiring, or the engine not running at all. Inspect the contact breaker in accordance with the periodic maintenance chart (Pg. 172), and repair or replace if necessary.

Clean the points with clean paper or cloth or using an oil-free solvent. A business card soaked in trichloroethylene can be used to remove traces of oil. To repair light damage, use emery cloth or an oilstone. If the points are badly worn down or damaged, or if the spring is weak, replace the contact breaker.

Whenever the contact breaker is inspected or replaced, apply a small amount of grease to the felt to lubricate the cam in order to minimize wear of the contact breaker heel. Be careful not to apply so much grease that it can drop off or be thrown onto the points, which will cause the points to foul and burn.

### Condenser inspection

The condenser can usually be considered to be

#### Condenser Test

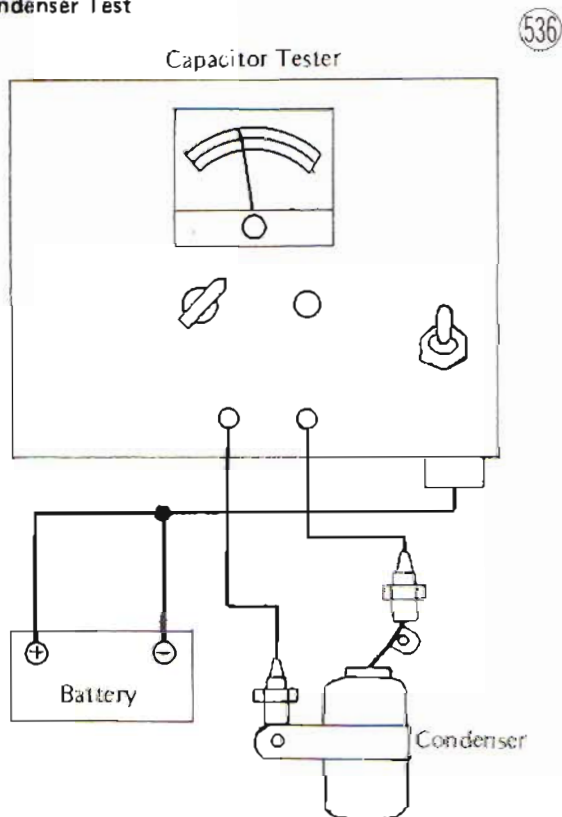

defective if a long spark is seen arcing across the points as they open or if the points are burned or pitted for no apparent reason. Replace the condenser any time it appears defective and whenever the contact breaker is replaced.

**NOTE:** For checking with a capacitor tester, condenser specifications are:  $0.22 \pm 0.02 \mu\text{fd}$ , 1,000 WVDC.

### Ignition coil inspection

The most accurate test for determining the condition of the ignition coil is made with the Kawasaki electrotester. The ignition coil must be connected to the tester in accordance to the tester directions and should produce at least a 5 mm spark. Since an electrotester other than the Kawasaki electrotester may produce a different arcing distance, the Kawasaki electrotester is recommended for a reliable result.

If an electrotester is not available, the coil can be checked for a broken or a badly shorted winding with an ohmmeter. However, an ohmmeter cannot detect layer shorts and shorts resulting from insulation breakdown under high voltage.

To measure the primary winding resistance, set the ohmmeter to the Rx1 range, and connect one ohmmeter lead to the red/yellow lead and the other to the blue lead from the ignition coil. The resistance should be  $3.8 \sim 4.2 \Omega$ . To measure the secondary winding resistance, set the ohmmeter to the Rx100 range, and connect one ohmmeter lead to one of the spark plug leads and the other ohmmeter lead to the remaining spark plug lead. The resistance should be about  $13\text{K}\Omega$ .



#### Ignition Coil Test

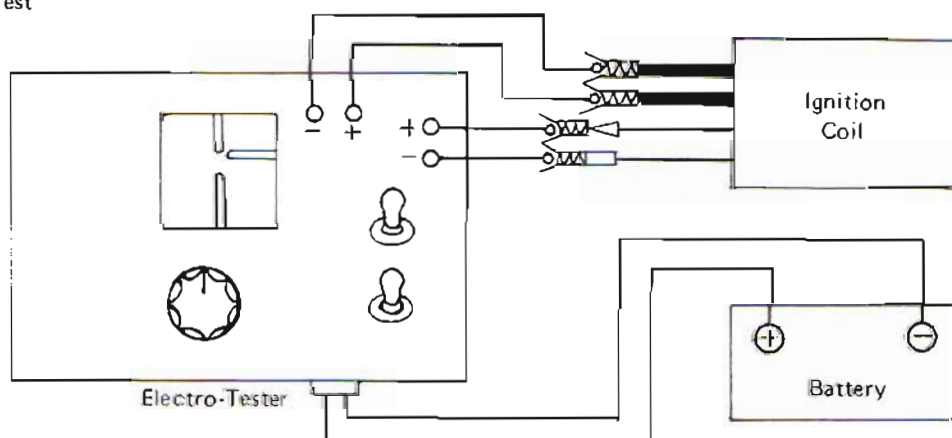



If the coil does not produce an adequate spark, or if either the primary or secondary winding does not have the correct resistance, replace the ignition coil.

Check with the highest ohmmeter range for continuity between the red/yellow lead and the coil core and between the plug leads and the coil core. If there is any reading, the coil is shorted and must be replaced. Also, replace the ignition coil if either spark plug lead shows visible damage.

### TIMING ADVANCER

The timing advancer is a device that advances the ignition timing (makes the spark plugs fire sooner) as engine rpm rises. It consists of two weights and two springs connected to the timing cam that opens the contact breaker points. The more that the engine speed rises, the more that the weights are thrown out against spring tension, turning the cam in the direction of crankshaft rotation and causing the points to open sooner.

If the mechanism is damaged, has weak or broken spring(s), or does not move smoothly, the ignition timing will not advance smoothly or it may stick in one position. This will result in incorrect timing at certain engine speeds, causing poor engine performance. Failure to advance at all will cause poor high speed performance, and excessive advance will cause knocking and poor low speed performance.

Ignition Timing/Engine rpm Relationship

540

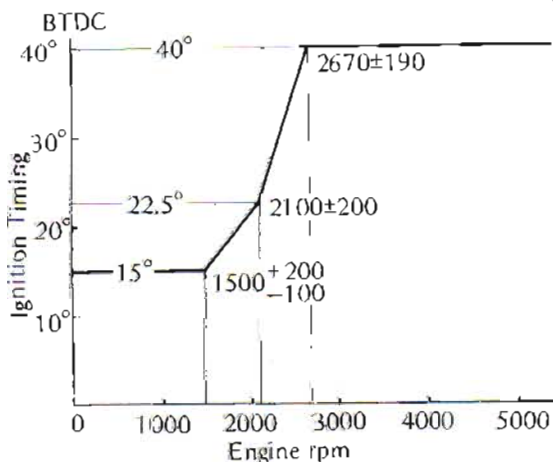

### Inspection and lubrication

Remove the timing advancer (Pg. 47 ), and check that the mechanism moves smoothly by hand and that no parts are visually worn or damaged. Wipe the advancer clean, apply oil to it, and fill the groove in the advancer body with grease.

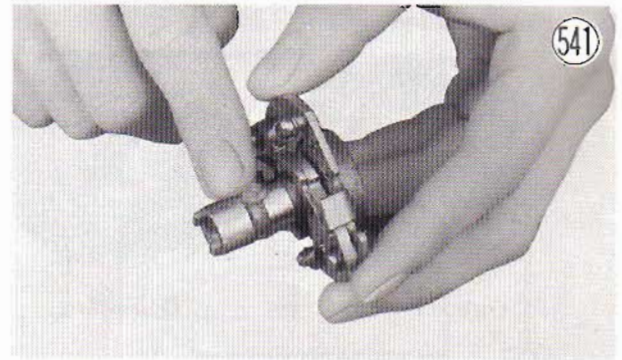

Replace the advancer (Pg. 48 ), adjust the timing (Pg. 12 ), and check it with a strobe light for both low and high speed operation (Pg. 13 ). If the timing differs from that which is shown in the graph (Fig. 540), replace the timing advancer for a new one.

### SPARK PLUGS

The spark plugs ignite the fuel/air mixture in the combustion chambers. To do this effectively and at the proper time, the correct spark plugs must be used, and the spark plugs must be kept clean and adjusted.

#### Spark Plug

542

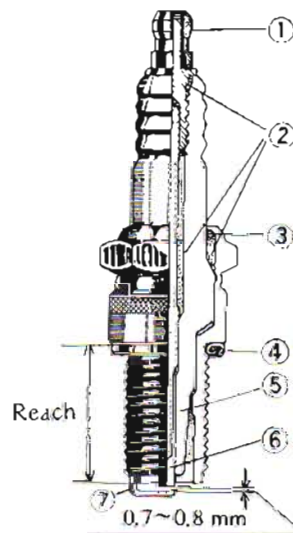

1. Terminal
2. Cement
3. Wire Ring
4. Gasket
5. Insulator
6. Center Electrode
7. Side Electrode

Tests have shown the NGK B-8ES or ND W24ES set to a 0.7~0.8 mm gap to be the best plug for general use. But since spark plug requirements change with ignition and carburetion adjustments and with riding conditions, this plug may have to be replaced for one of the next higher or lower heat range. Whether or not a spark plug of a different heat range should be used is generally determined upon removing and inspecting the plug.

When a plug of the correct heat range is being used, the electrodes will stay hot enough to keep all the carbon burned off but cool enough to keep from damaging the engine and the plug itself. This temperature is about 400~800°C (750~1450°F) and can be judged by noting the condition and color of the ceramic insulator around the center electrode. If the ceramic is clean and of a light brown color, the plug is burning at the right temperature.

Spark Plug Condition

543



Carbon Fouling



Oil Fouling

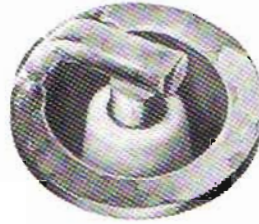

Normal Operation

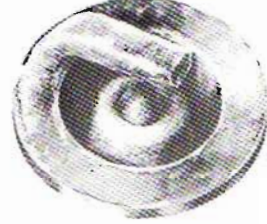

Overheating

A spark plug for higher operating temperatures is used for racing and other high speed applications. Such a plug is designed for better cooling efficiency so that it will not overheat and thus is often called a "colder" plug. If a spark plug with too high a heat range is used—that is, a "cold" plug that cools itself too well—the plug will stay too cool to burn off the carbon, and the carbon will collect on the electrodes and the ceramic insulator. If enough of this carbon collects, it may prevent a spark from jumping across the gap, or it may short the spark out by bridging across the electrodes or by conducting along the outside of the ceramic. Carbon build-up on the plug can also cause the electrodes to heat up red-hot, which will cause preignition, indicated by knocking, which in turn may eventually burn a hole in the top of the piston.

A spark plug in the lower heat range is used when engine temperature is comparatively low such as for constant city use or during the break-in period when the motorcycle is not operated at high speed. Such a plug is designed to hold the heat and thus is often referred to as a "hotter" plug. If a "hot" plug is used for racing or other high speed use, the plug will be too hot, causing engine overheating and preignition.

Inspection and replacement

Remove each plug and inspect the ceramic insulator. If the insulator is clean and has a light brown color, the correct plug is being used. If it is fouled black, change to the "hotter" NGK B-7ES. If the ceramic is burned white and the electrodes are burned, replace the plug with the "colder" NGK B-9ES. However, if the spark plug still fouls or overheats after changing to a hotter or colder plug, the cause of the trouble may be other than the spark plug such as faulty carburetion or ignition timing.

**CAUTION:** When the type of riding changes—for example, a change to faster riding after the break-in period is over—the spark plugs should be inspected and changed if necessary. The NGK B-7ES plug in particular can damage the engine if used for high speed riding.

Clean the electrodes and the ceramic insulator around the center electrode by scraping off any deposits and cleaning the plug in a high flash point solvent of some kind. If the gap has widened, reset it to the standard 0.7 ~ 0.8 mm gap. If the electrodes are badly worn down or burned, replace the plug. A plug must also be replaced any time there is visible damage such as cracked ceramic or damaged threads.

**NOTE:** If the spark plugs are replaced by any other than the recommended NGK B-7ES, B-8ES (standard) or B-9ES, make sure that the replacement plugs have

the same:

- (1) thread pitch
- (2) reach (length of threaded portion must be 19 mm)
- (3) diameter (diameter at threads must be 14 mm)
- (4) electrode configuration (standard, not projected insulator or racing)

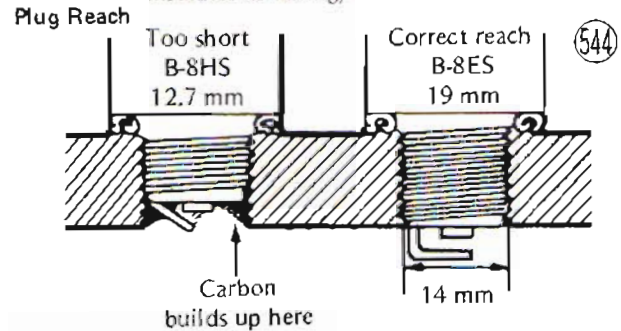

544

If a plug with the wrong thread pitch or thread diameter is used, the cylinder head will be damaged. If a plug with too long or short a reach is used, carbon will build up around the plug or plug hole threads, possibly causing engine damage and making the old plug difficult to remove or the new one difficult to install.

STARTER MOTOR CIRCUIT

The starter motor circuit includes the starter button (switch), starter relay, battery, and starter motor. When the ignition switch is on and the starter button is pushed, a small amount of current flows through the switch and the relay coil. This current magnetizes the relay core, which then pulls the armature to it, closing the relay contacts. The closed contacts complete a circuit for the starter motor, and the motor turns. The reason for using a relay instead of using the switch to turn on the starter motor directly is that the starter motor requires much current — enough that relatively thick wire is necessary to carry the current to the starter motor. Because it is not practical to put a heavy switch on the handlebar and have large wires running to it, the starter switch is made to carry just the light relay coil current, and heavy contacts inside the relay carry the starter motor current.

**NOTE:** Because of the large amount of current, never keep the starter button pushed any time that the starter motor will not turn over, or the current may burn out the starter motor windings.

The starter motor is installed with a sprocket and chain arrangement to transmit starter motor rotation to the crankshaft. In place of the solenoid used in automobiles, a clutch (Pg. 163) disengages the starter motor once the engine starts.

**Starter Motor Circuit**

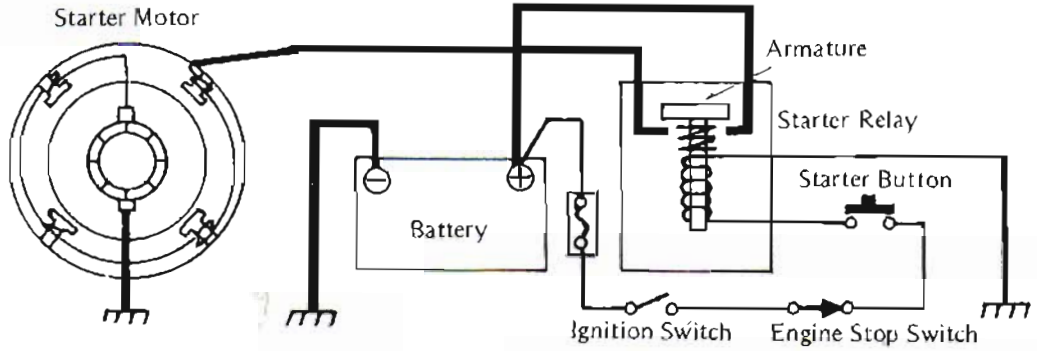

Fig. 547 shows starter motor construction. The field coils are wound around four cores, forming the yoke, and the armature windings are connected to the commutator and receive their current through the brushes. If the brushes are not making good contact, no starter motor current will flow at all since the field coils and armature windings are connected in series, and the motor will not turn over. A short or open in a coil or winding may also cause the motor to be inoperative. Particles from brush wear may be another cause of starter motor failure; these particles may get onto the bearing at the rear of the motor, causing heat seizure.

Gears are provided at the output side of the starter motor. These gears reduce the rotational speed of the armature to give more power to the output shaft.

**Carbon brushes**

Worn brushes or weak springs will cause poor brush contact.

Measure the length of the brushes, and replace both if either one is worn down to less than the service limit.

**Table 88 Starter Motor Brush Length**

Standard	Service Limit
11.0~12.5 mm	6 mm

**Starter Motor Construction**

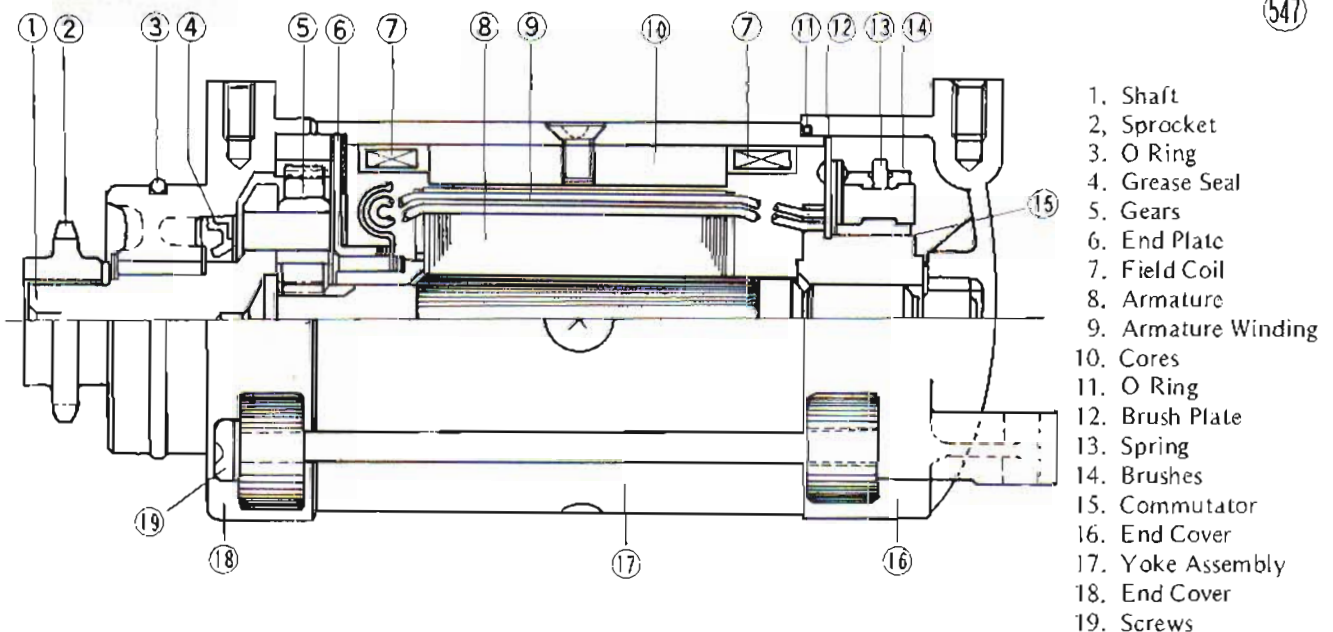

1. Shaft
2. Sprocket
3. O Ring
4. Grease Seal
5. Gears
6. End Plate
7. Field Coil
8. Armature
9. Armature Winding
10. Cores
11. O Ring
12. Brush Plate
13. Spring
14. Brushes
15. Commutator
16. End Cover
17. Yoke Assembly
18. End Cover
19. Screws

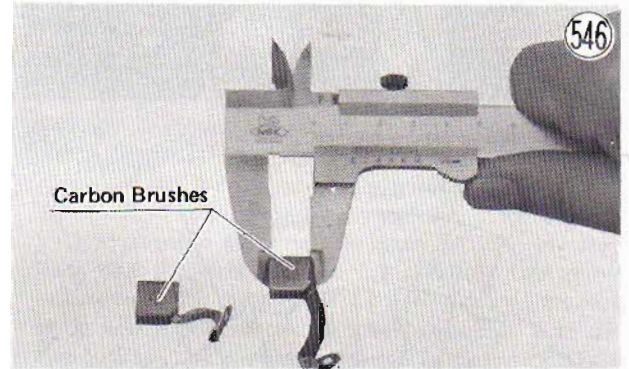

Spring tension should be 495~605 grams but a spring can be considered serviceable if it will snap the brush firmly into place.

**Commutator**

A dirty or damaged commutator will result in poor brush contact and cause the brushes to wear down quickly. In addition, particles from brush wear accumulating between commutator segments may cause partial shorts.

Correct the commutator surface if necessary with fine emery cloth, and clean out the grooves as illustrated. Determine as accurately as possible the depth

## 162 MAINTENANCE

of the grooves between commutator segments. Replace the armature for a new one if the groove depth is less than the service limit.

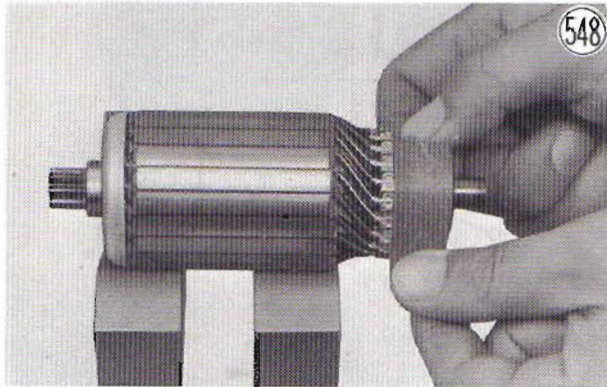

Commutator

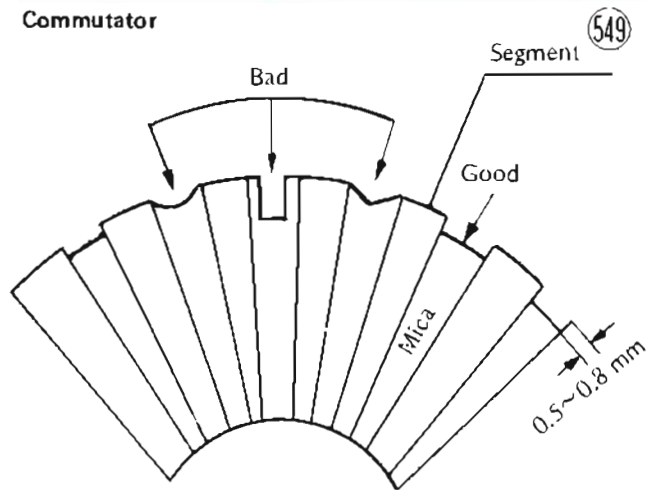
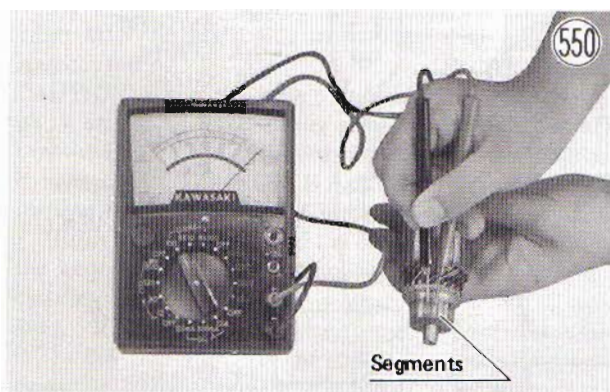

Table 89 Commutator Groove Depth

Standard	Service Limit
0.5~0.8 mm	0.2 mm

Using the R x 1 ohmmeter range, measure the resistance between each two commutator segments. If there is a high resistance or no reading between any two segments, a winding is open and the armature must be replaced.



Using the highest ohmmeter range, measure the resistance between the commutator and the shaft. If there is any reading at all, the armature has a short and must be replaced.

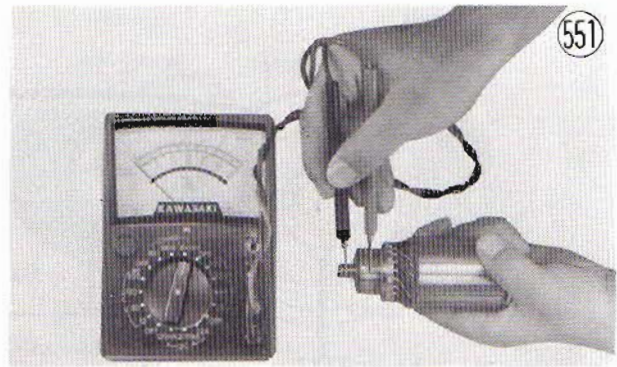

Even if the foregoing checks show the armature to be good, it may be defective in some manner not readily detectable with an ohmmeter. If all other starter motor and starter motor circuit components check good, but the starter motor still does not turn over or only turns over weakly, replace the armature for a new one.

### Field coils

Using the R x 1 ohmmeter range, measure the resistance between the + side carbon brush and the starter motor lead. If there is not close to zero ohms, the field coils have an open and the yoke assembly must be replaced.

### Field Coil Test

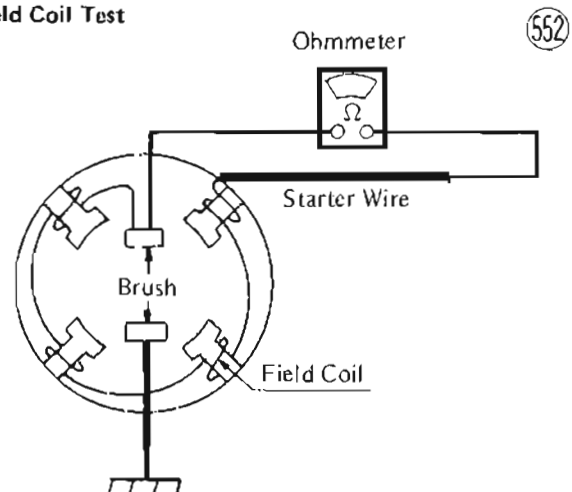

Using the highest ohmmeter range, measure the resistance between the + side carbon brush and the yoke (housing). If there is any meter reading, the coils are shorted to ground and the yoke assembly must be replaced.

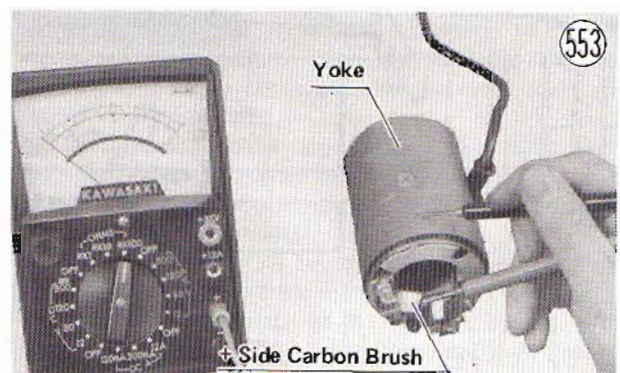

**Starter Relay Contact Test**

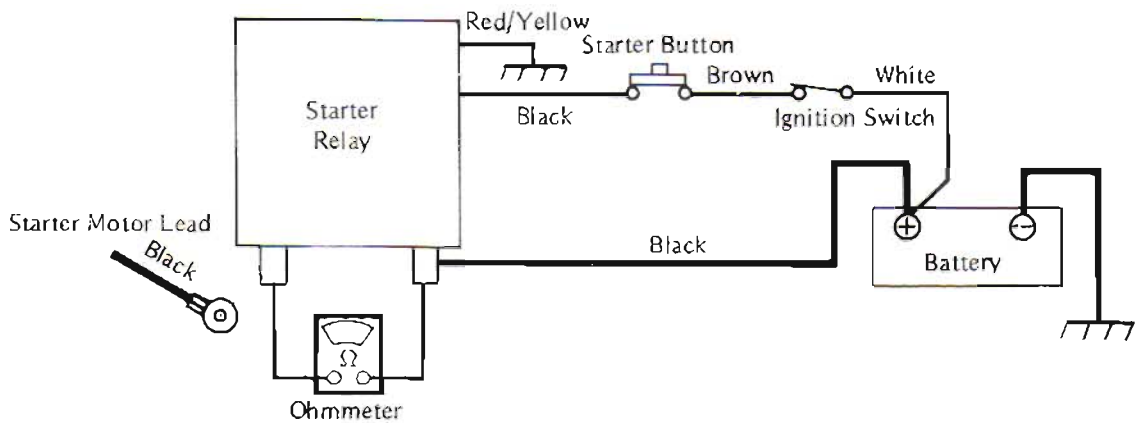

554

**Starter relay**

Disconnect the starter motor lead from the starter relay, and connect an ohmmeter set to the R x 1 range across the relay terminals. Push the starter button, and see if the meter reads zero ohms. If the relay makes a single clicking sound and the meter reads zero, the relay is good. If the relay clicks but the meter does not read zero, the relay is defective and must be replaced.

If the relay does not click at all, disconnect the other two leads (black and yellow/red), and measure the resistance across them. If the resistance is not close to zero ohms, the relay is defective.



555

However, if there is zero ohms resistance, the relay may be good; check that there is actually voltage to the relay before deciding that the relay is defective. To check for the voltage, first turn the meter to 30 VDC, connect the - meter lead to the yellow/red lead which was disconnected from the relay, and connect the + meter lead to the black lead. When the starter button is pushed, the meter should read battery voltage. If it does not, there is wiring trouble. If the meter does not read battery voltage but the relay does not click, the relay is defective.

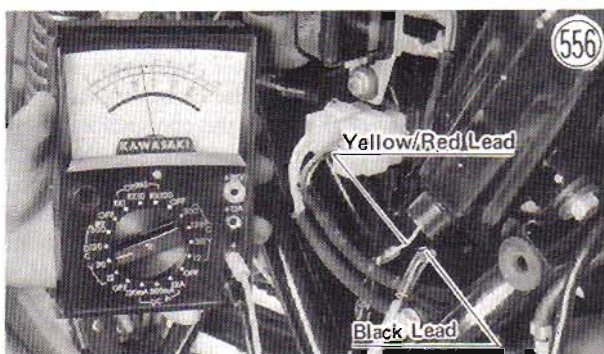

556

**STARTER MOTOR CLUTCH, CHAIN**

Fig. 557 shows starter motor clutch construction. The clutch body is fixed to the crankshaft through the rotor. When the starter clutch sprocket rotates in the direction of the arrow, each of the three rollers is wedged into the more narrow space between the clutch body and the starter clutch sprocket hub (the portion jutting out from the sprocket), thereby locking the clutch body and starter clutch sprocket together. With these two locked, starter motor rotation is transmitted to the crankshaft through the starter chain, starter clutch sprocket, rollers, clutch body, and rotor.

When the engine starts, at first friction with the starter clutch sprocket (and at higher speeds, inertia) moves the rollers back against the tension of their springs so that they no longer serve as wedges locking the clutch body and starter clutch sprocket together. In this manner, the engine rotates freely without forcing the starter motor to turn with it.

**Starter Motor Clutch**

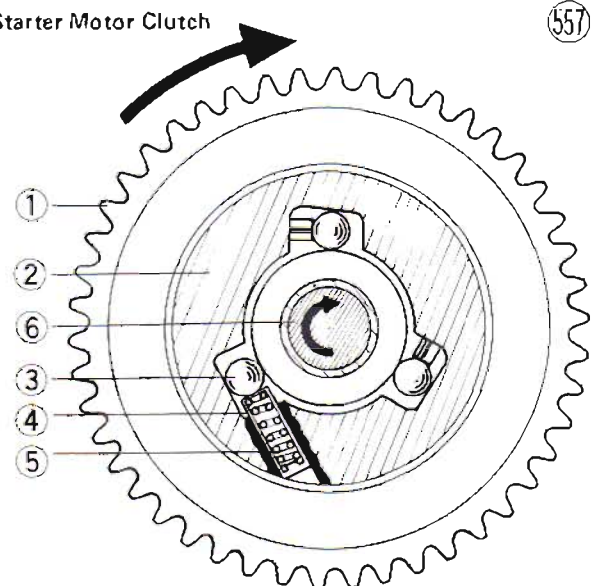

557

- 1. Sprocket
- 2. Starter Clutch
- 3. Roller
- 4. Spring Cap
- 5. Spring
- 6. Crankshaft

If the rollers or the starter clutch sprocket hub becomes damaged or worn, the rollers may lock in

## 164 MAINTENANCE

place so that the starter motor will not disengage when the engine starts. On the other hand, roller or sprocket hub damage could prevent the clutch from engaging properly, causing the starter motor to run freely without transmitting the rotation to the crankshaft or to make noise while transmitting rotation.

### Clutch inspection

Remove the dynamo cover, and turn the rotor by hand. When turning the rotor counterclockwise, the starter clutch sprocket should turn with the rotor, but, when turning the rotor clockwise, the sprocket should not turn. If the clutch does not operate as it should or if it makes noise, disassemble the starter motor clutch (Pg. 44), examine each part visually, and replace any worn or damaged parts.

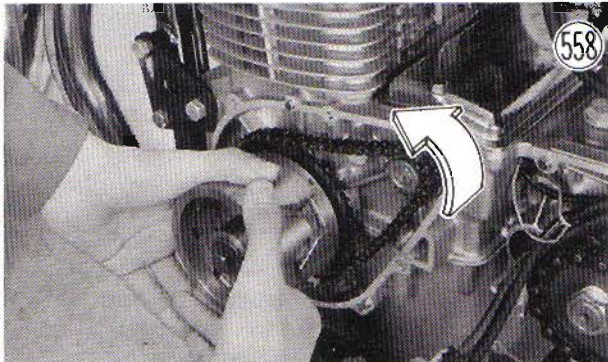

### Starter chain inspection

Remove the starter chain (Pg. 45), hold the chain taut with a force of about 5 kg in some manner such as the one shown in Fig. 559, and measure a 20-link length. If the chain has lengthened beyond the service limit, replace it for a new one.

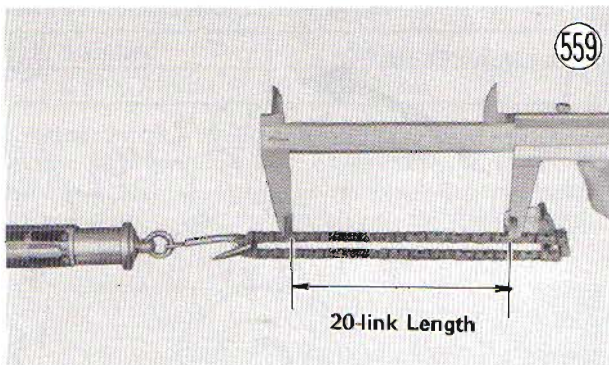

Table 90 Starter Chain Length

Standard	Service Limit
155.5 mm	157.8 mm

## IGNITION SWITCH

The ignition switch has three positions: off, on, and park. In the off position, all circuits are turned off and the key can be removed from the switch. In the on position, the motorcycle can be started, all electrical equipment can be used, the headlight, tail light, and meter illuminating lights are lit, and the key is held in the switch so that it can not be removed. In the park position, the tail light goes on so that the motorcycle

can be more safely stopped along the road at night, all other electrical circuits are cut off, and the key can be removed from the switch.

### Testing the switch

Table 91 shows the internal connections of the ignition switch for each switch position. To check the switch, disconnect the lead plug from the switch, and use an ohmmeter to verify that there is continuity (zero ohms) between all the connections that are listed in the table for each switch position, and that there is no continuity between the leads that are not connected. If the switch has an open or short, replace the switch for a new one.

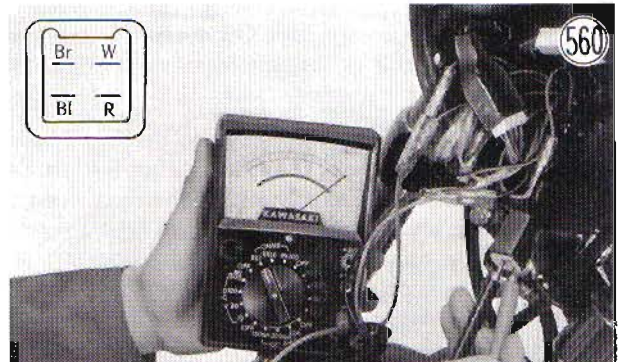

Table 91 Ignition Switch Connections

LEAD	BAT	IG	TL 1	TL 2
OFF				
ON	●	●	●	●
Park	●			●
COLOR	White	Brown	Blue	Red

## HEADLIGHT CIRCUIT

The headlight circuit is shown in Fig. 561. When the ignition switch is turned on, the headlight circuit is completed, turning on the headlight, tail light, and meter illumination lights. The dimmer switch is used to select high or low beam. When the headlight is on high beam, the high beam indicator light also is lit.

The same bulb is used for both the tail and the brake light, but the bulb has a separate filament for each light. The tail light filament is controlled by the headlight circuit, which is explained here. The brake light filament is controlled by the brake light circuit, which is explained in the following section.

### Headlight trouble

If the headlight does not light, check to see if the bulb has burned out. If the bulb has burned out, the sealed beam unit must be replaced. If the bulb is good, check the dimmer switch. Table 92 shows the connections in the dimmer switch for both high and low beam. Disconnect the leads to the dimmer switch, and use an ohmmeter to see that only the connections shown in the table have continuity (zero ohms). If the switch has an open or a short, it can be disassembled for repair. The contact surfaces may be cleaned, but no internal parts are available for replacement. If any parts are not repairable, the switch must be replaced as a unit. However, if the dimmer switch is good, check the ignition

Headlight Circuit

561

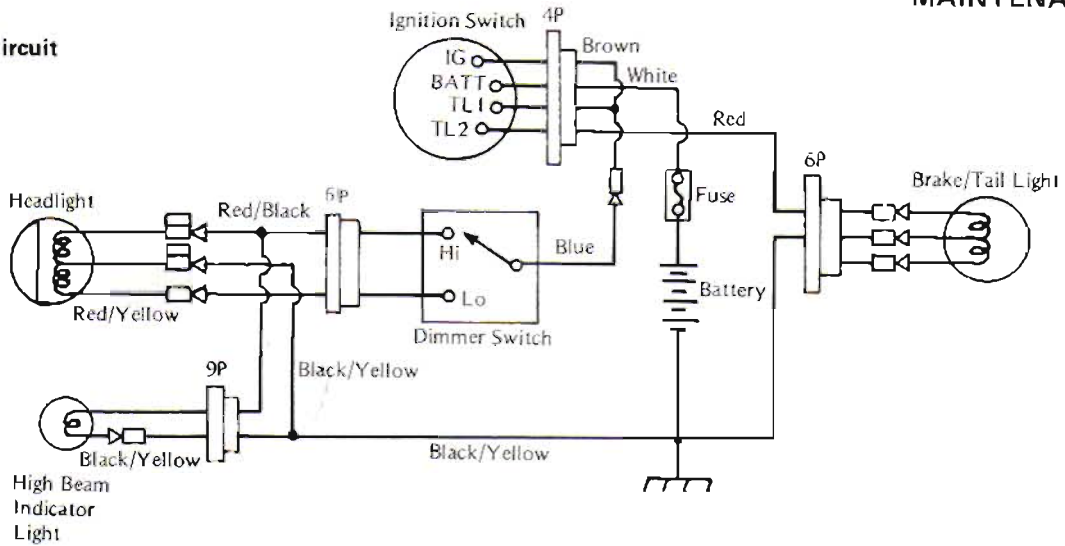

switch, the wiring, and the dynamo.

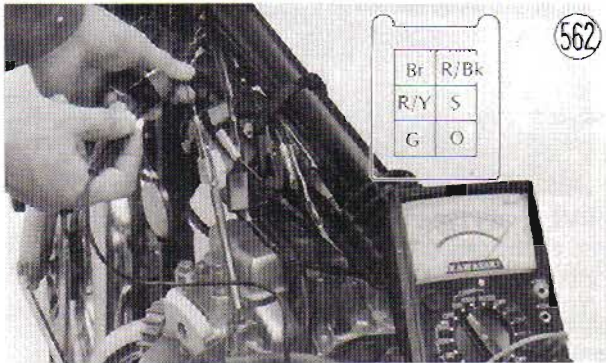

562

Table 92 Dimmer Switch Connections

Color	R/Y	Blue	R/Bk
High Beam		●	●
Low Beam	●	●	

If the headlight lights but does not light brightly, the trouble may be that the headlight is of the improper wattage or that the dynamo is not putting out sufficient current. However, the trouble may be also caused by a short or a component drawing too much current in some other part of the electrical system.

Tail light trouble

If the tail light does not go on when the ignition switch is turned on, the filament is probably burned out. However, if the bulb is good, check the wiring, ignition switch, fuse, and battery.

BRAKE LIGHT CIRCUIT

The brake light circuit is shown in Fig. 563. When the ignition switch is turned on, the brake light goes on whenever the circuit is closed by either the front or rear brake light switch. The same bulb is used for both the brake and tail lights as explained in the preceding section.

The front brake light switch, a fluid pressure switch mounted on the front brake line, is actuated when the front brake lever is pulled. The rear brake light switch, a plunger type of switch, is actuated when pulled on by a spring attached to the rear brake pedal. The front brake light switch does not require any adjustment, but the rear switch must be adjusted by changing its position higher or lower in the mounting bracket so that the brake light goes on after a certain amount of brake pedal travel when the brake pedal is applied (Pg. 19 ). Neither switch can be disassembled for repair; a switch must be replaced as a unit if defective.

Brake Light Circuit

563

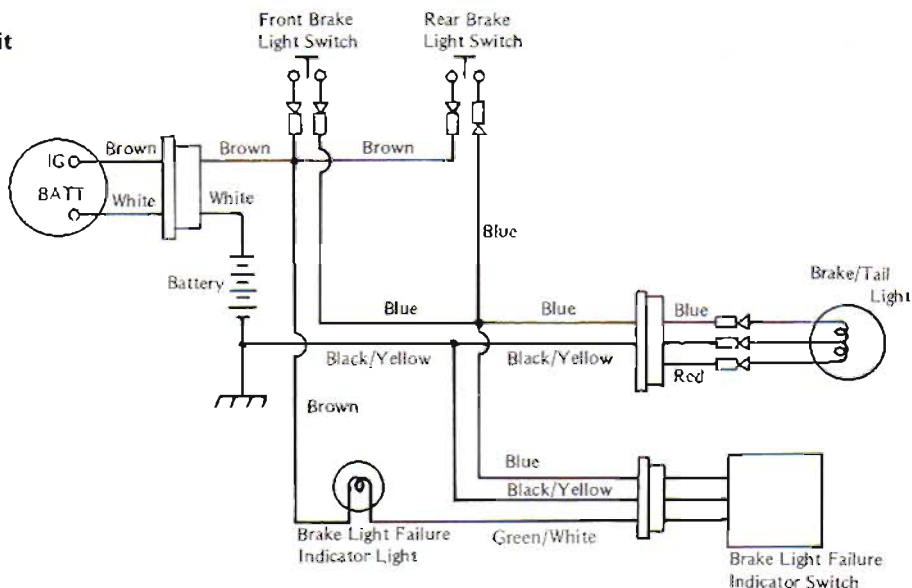

The brake light failure indicator switch is in the brake light circuit as a warning device to indicate during vehicle operation whether or not the brake light is functioning properly. Brake light failure may be due to a burned out bulb or some other failure in the brake light circuit.

**Brake light circuit trouble**

Brake light circuit inspection involves the front brake light switch, rear brake light switch, brake light, brake light failure indicator switch, brake light failure indicator light, and wiring.

**[I] Front brake light switch inspection**

- Disconnect the front brake light switch leads.
- Set an ohmmeter to the R x 1 range, connect the meter to the switch terminals, and determine whether or not there is continuity whenever the front brake lever is squeezed. If there is no continuity, replace the switch.



**NOTE (when the front brake light switch is replaced for a new one):**

1. If brake fluid spills when the switch is replaced, painted or chromed surfaces may become damaged. If any fluid spills on the fender or elsewhere, wipe it up immediately.
2. Apply a small amount of a non-permanent locking agent such as Kawasaki Liquid Lock-K to the switch threads before mounting the switch. However, so that no Lock-K will get mixed in with the brake fluid, do not apply any on the lower fourth of the threads.
3. After the switch has been installed, air bleed the front brake lines.

**[II] Rear brake light switch inspection**

- Disconnect the rear brake light switch leads.
- Inspect in the same way that the front brake light

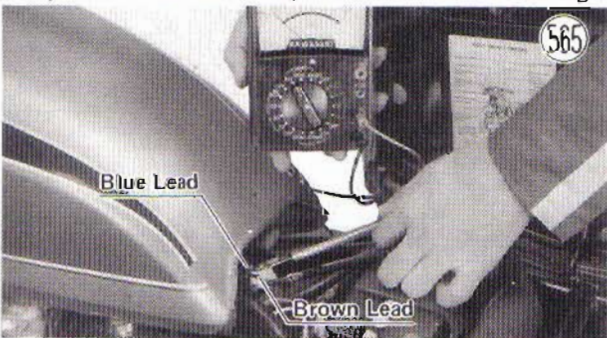

**Table 93 Indicator Light Operation**

Brakes	Components	Brake Light	Indicator Light
Brake Being Applied	All Normal	On	On
	Brake Light Burned Out	Off	On
Brake Not Applied	All Normal	Off	Off
	Brake Light Burned Out	Off	Flashes

switch was inspected. If there is no continuity whenever the rear brake pedal is depressed, replace the switch.

**[III] Brake light failure indicator switch inspection**

- Turn on the ignition switch, and apply the brakes. At this time the indicator light should go on.
- With the brake applied, remove the brake light bulb. At this time the indicator light should still be lit.
- With the brake applied and the bulb removed as in the previous step, release the brake. The indicator light should flash at a rate of 70~170 times a minute. If the above conditions are met, the brake light failure indicator switch is functioning properly.

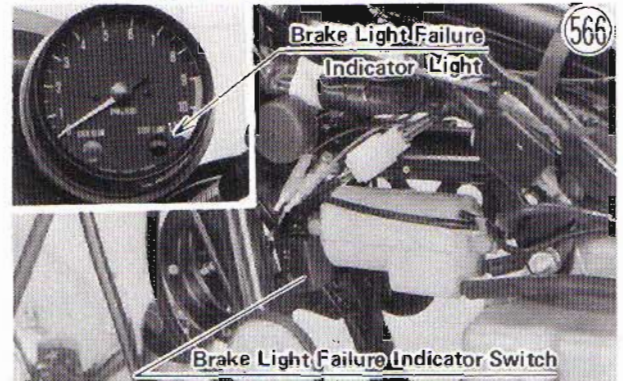

**[IV] Brake light circuit inspection**

(in all the measurements the - meter lead goes to chassis ground)

- (1) Even though the brake light lights, the indicator light does not go on:
  - Measure battery voltage.
  - Turn on the ignition switch.
  - Set a voltmeter to the 30 VDC range, and connect the meter to the blue indicator switch lead and to ground without disconnecting the indicator switch. If the voltage is less than battery voltage, the wiring is defective.



- Measure the voltage between the green/white indicator switch lead and ground. If the voltage is less than battery voltage, the indicator light is burned out; if the voltage is the same as battery voltage, the indicator switch is defective.

- (2) The brake light is burned out, and, with neither brake applied, the indicator light doesn't flash:
  - a. the indicator light lights without flashing

- Measure battery voltage.
- Turn on the ignition switch.
- Set a voltmeter to the 30 VDC range, and measure the voltage between the blue indicator switch lead and ground. If the voltage is less than battery voltage, the indicator switch is defective; if the voltage is the same as the battery voltage, either the front or the rear brake light switch is defective.
- b. the indicator light does not light
- Measure battery voltage.
- Turn on the ignition switch.
- Set a voltmeter to the 30 VDC range, and measure the voltage between the green/white indicator switch lead and ground. If the voltage is less than battery voltage, the indicator light is burned out; if the voltage is the same as battery voltage, the indicator switch is defective.
- (3) Although the brake light is not burned out, the indicator light either lights even when neither brake is being applied or flashes:
  - a. the indicator light does not go off when the brake is released
  - If the brake light also won't go off when the brake is released, the brake light switch is defective; if it doesn't light, the indicator switch is defective.
  - b. the indicator light flashes
  - Measure the battery voltage.
  - Turn on the ignition switch.
  - Set a voltmeter to the 30 VDC range, and connect the meter to the blue indicator switch lead and to ground. Apply one of the brakes, and note the voltage. If the voltage is less than battery voltage, the wiring is defective; if the voltage is the same as battery voltage, the indicator switch is defective.

**TURN SIGNALS**

A wiring diagram of the turn signal circuit is shown in Fig. 569. When the ignition switch is on and the turn signal switch is turned to R or L, a ground is provided for the circuit so current can flow. Current to the right or left turn signals flows through the closed contacts and the resistance wire inside the turn signal relay, and the turn signals go on. The resistance wire quickly heats up, expands, and allows a spring to pull the contacts open. When the contacts have opened, the circuit is broken, the turn signals go off, and the

**Turn Signal Circuit**

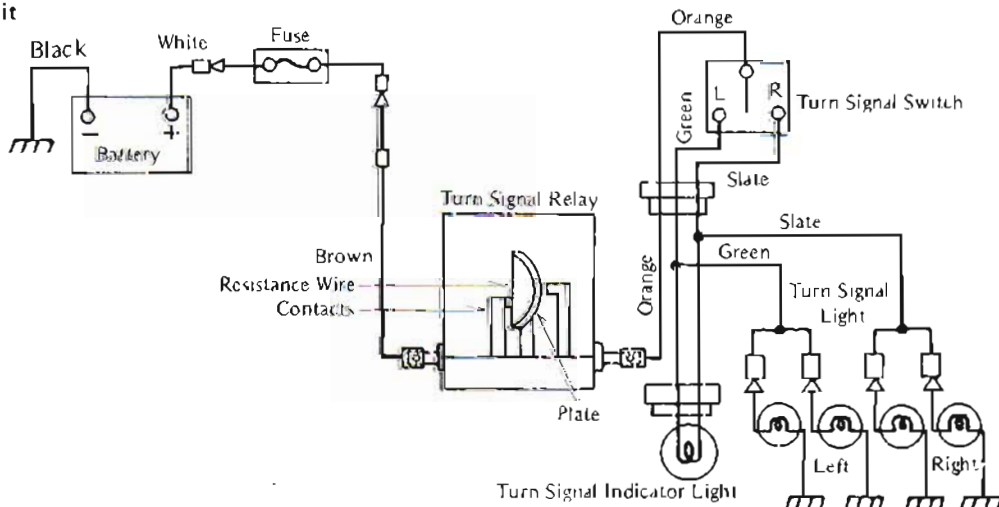

resistance wire cools and contracts, closing the contacts so that the cycle can begin again. The indicator light in the turn signal circuit flashes on and off with the turn signals to indicate that they are working properly.

Since the turn signal relay is designed to operate correctly only when two turn signals (one front and one rear) and the turn signal indicator light are properly connected in the circuit, trouble may result from a burned out bulb, a bulb of incorrect wattage, loose wiring, as well as from a defect in the relay itself. In general, if the trouble with the circuit is common to both right and left turn signals, it is probably caused by a defective turn signal relay, although it may be due to a bad switch, wiring, or battery. If the trouble is with only one side—either right or left—then the relay is not at fault since the same relay is used for both sides.

**Turn signal trouble**

- (1) Neither right nor left turn signals come on at all:
  - Check that battery voltage is normal.
  - Unplug the relay leads and use an ohmmeter to check that there is continuity (close to zero ohms) between the relay terminals. If there is no ohmmeter reading, or if there is several ohms resistance, replace the relay for a new one.



- If the relay checks good, turn the meter to the 30 VDC range, connect the + meter lead to the brown lead that was disconnected from the relay, and connect the - meter lead to the orange lead. With the ignition switch on, first switch the turn signal switch to the R and then to the L position. The meter should register battery voltage at either position. If it does not, the fuse, ignition switch,

## 168 MAINTENANCE

or wiring is at fault. If battery voltage is read on the meter but the turn signals will still not work when the relay is reconnected, then recheck all wiring connections.

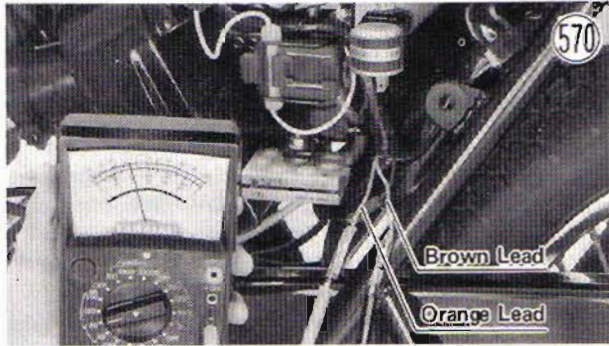

- (2) Both right or both left turn signals come on and stay on or flash too slowly:
  - Check that battery voltage is not low.
  - Check that all wiring connections are good.
  - Check that the turn signal bulbs and indicator bulb are of the correct wattage.
  - If all of the above check good, replace the relay.
- (3) A single light on one side comes on and stays on:
  - Either the light that does not come on is burned out or of the incorrect wattage, or the wiring is broken or improperly connected.
- (4) Neither light on one side comes on:
  - Unless both lights for that side are burned out, the trouble is with the turn signal switch.
- (5) Flashing rate is too fast:
  - If this occurs on both the right and left sides, check that the battery is not being overcharged (indicating a defective regulator). If the dynamo and the battery voltage are normal, replace the turn signal relay.
  - If this occurs on only one side, one or both of the turn signal bulbs are of too high a wattage.

### HORN

The horn circuit and construction are shown in Fig. 571. When the horn button is pressed with the ignition switch on, the horn is grounded to complete the horn circuit. Current then flows through the horn contacts and horn coil, magnetizing the iron core. The magnetized iron core pulls on the armature and diaphragm assembly, the movement of which pushes open the contacts, interrupting the current flow. Since the core now loses its magnetism, the armature and diaphragm assembly springs back to its original position, closing the contacts. This cycle repeats until the horn button is released. Since each cycle takes only a fraction of a second, the diaphragm moves fast enough to produce sound.

The contacts wear down after long use, requiring adjustment from time to time (Pg. 21). If the horn itself is determined to be at fault and adjustment fails to correct the trouble, the contacts or some other component in the horn is defective. The horn cannot be disassembled and must be replaced if defective.

#### Horn trouble

- Check that battery voltage is normal.
- Disconnect the leads to the horn, and connect to the horn leads a multimeter set to the R x 1 range

### Horn Construction

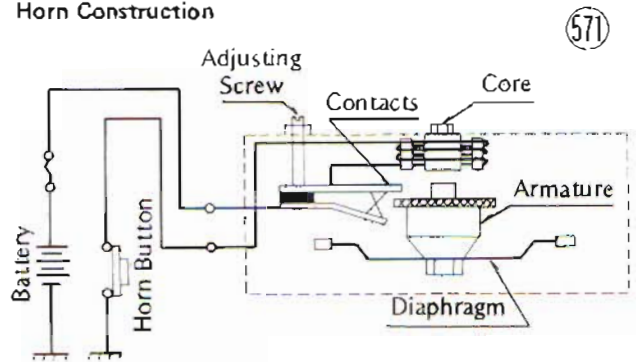

to check for continuity (close to zero ohms). If the reading is several ohms or if there is no reading at all, replace the horn.

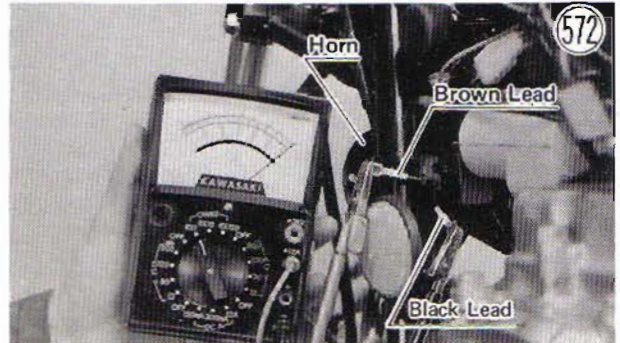

- If the reading is very close to zero, set the multimeter to the 30 VDC range, and connect the meter to the leads that were disconnected from the horn. The + meter lead goes to the brown lead, and the - meter lead goes to the black lead. With the ignition switch on, press the horn button. The meter should register battery voltage. If it does not, the fuse, ignition switch, or the wiring is at fault.
- If the meter does show battery voltage, indicating that the horn trouble lies within the horn itself, and adjustment fails to correct the trouble, replace the horn.

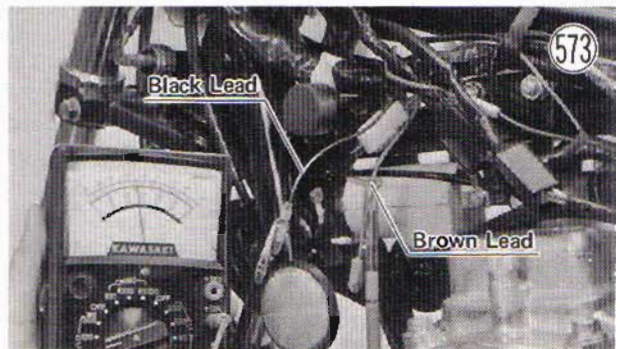

**NOTE:** Do not loosen the armature mounting since doing so would alter the armature position such that the horn would probably have to be replaced.

### SPEEDOMETER, TACHOMETER

The speedometer and the tachometer are sealed units which cannot be disassembled. If either fails to work satisfactorily, it must be replaced as a complete unit.

The speedometer and tachometer illumination lights and the indicator lights are independent and can be removed for replacement if necessary.

# Appendix

## SPECIAL TOOLS

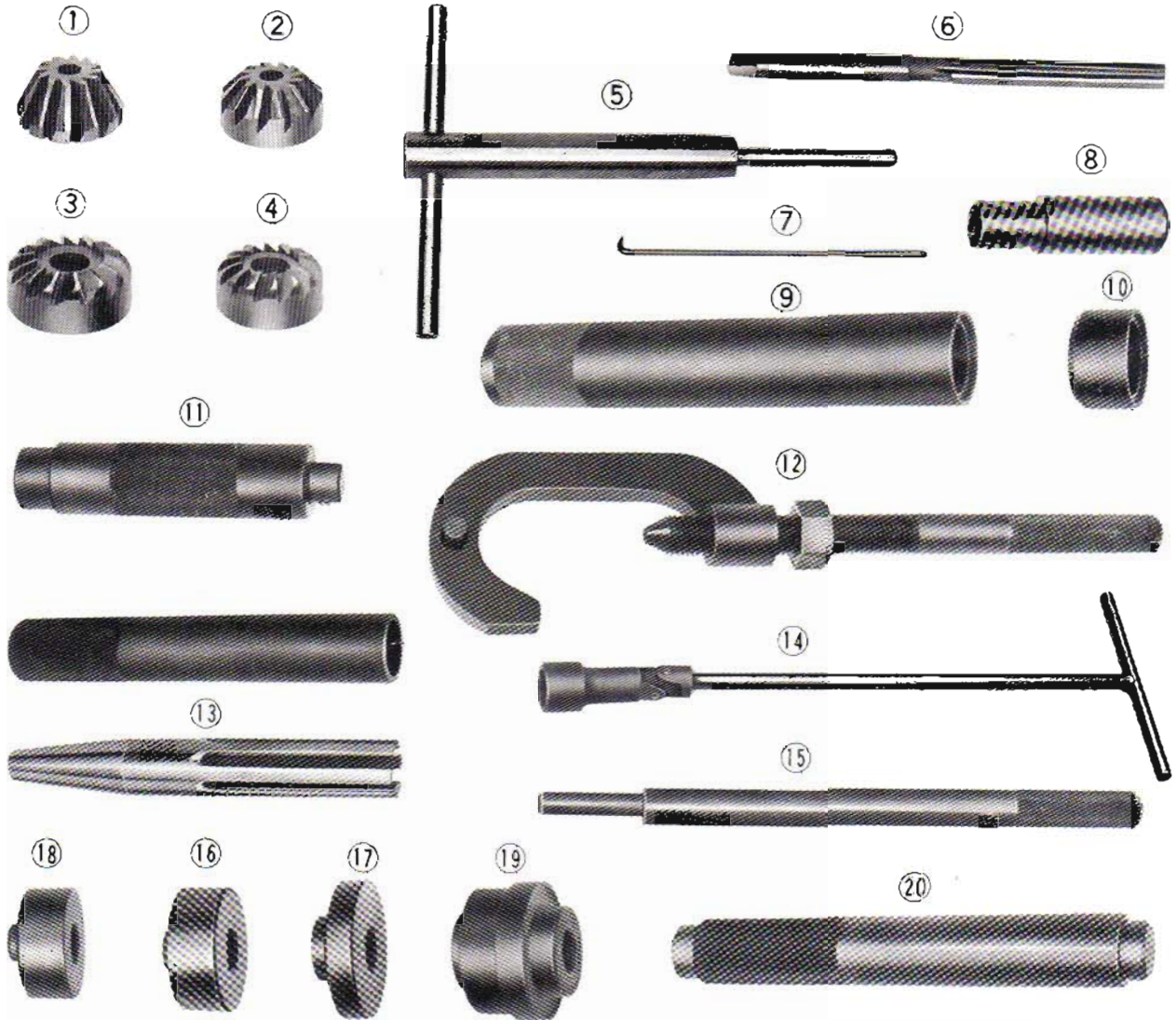

REF. NO.	TOOL NO.	DESCRIPTION
1	57001-101	VALVE SEAT CUTTER 30°
2	57001-102	VALVE SEAT CUTTER 45°
3	57001-360	INLET VALVE SEAT CUTTER 75°
4	57001-361	EXHAUST VALVE SEAT CUTTER 75°
5	57001-106	VALVE SEAT CUTTER HOLDER
6	57001-162	VALVE GUIDE REAMER
7	56019-111	MASTER CYLINDER STOPPER REMOVER
8	56019-110	MASTER CYLINDER RING DRIVER
9	57001-137	STEM BEARING DRIVER
10	57001-294	STEM BEARING DRIVER ADAPTER
11	57001-139	BEARING DRIVER HOLDER
12	56019-040	ENGINE SPROCKET HOLDER
13	57001-380	TRANSMISSION CIRCLIP DRIVER
14	57001-110	SPARK PLUG WRENCH
15	57001-163	VALVE GUIDE ARBOR
16	57001-288	WHEEL BEARING DRIVER "A"
17	57001-289	WHEEL BEARING DRIVER "B"
18	57001-290	WHEEL BEARING DRIVER "C"
19	57001-138	STEM CUP DRIVER
20	57001-285	SHIFT DRUM BEARING DRIVER

170 APPENDIX

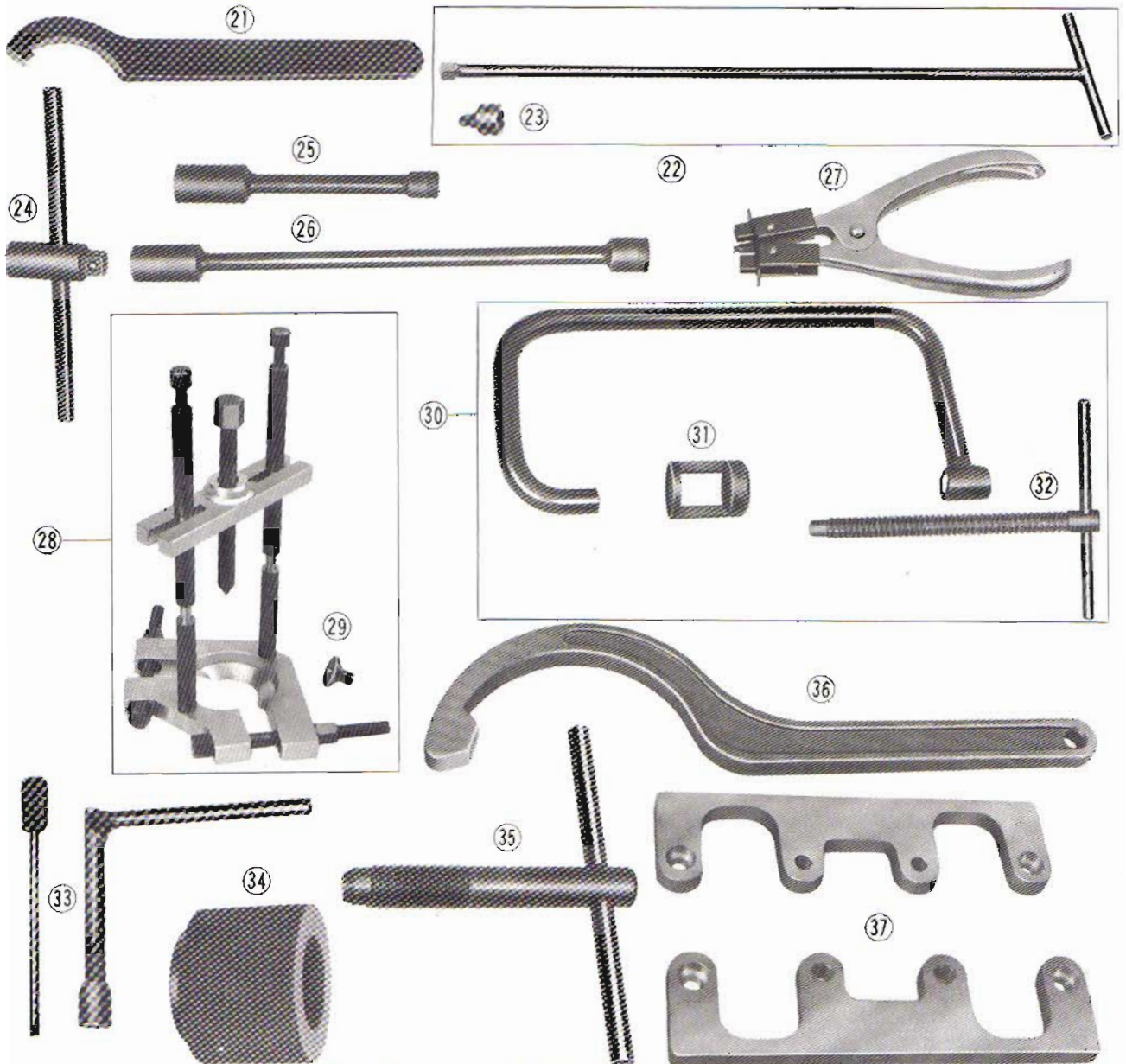

REF.NO.	TOOL NO.	DESCRIPTION
21	57001-134	STEM NUT WRENCH
22	57001-179	FRONT FORK CYLINDER HOLDER ASSEMBLY
23	57001-181	FRONT FORK CYLINDER HOLDER ADAPTER
24	57001-370	CYLINDER HEAD BOLT WRENCH HANDLE
25	57001-371	CYLINDER HEAD BOLT WRENCH SOCKET 10 mm
26	57001-372	CYLINDER HEAD BOLT WRENCH SOCKET 13 mm
27	57001-115	PISTON RING PLIERS
28	57001-158	STEM BEARING PULLER
29	57001-166	STEM BEARING ADAPTER
30	57001-241	VALVE SPRING COMPRESSOR ASSEMBLY
31	57001-242	VALVE SPRING COMPRESSOR ADAPTER
32	57001-244	VALVE SPRING COMPRESSOR CENTER SHAFT
33	57001-167	BALANCE ADJUSTER
34	57001-191	FRONT FORK OIL SEAL DRIVER
35	57001-254	DYNAMO ROTOR PULLER
36	57001-255	DYNAMO ROTOR HOLDER
37	57001-165	CYLINDER HEAD HOLDING PLATE

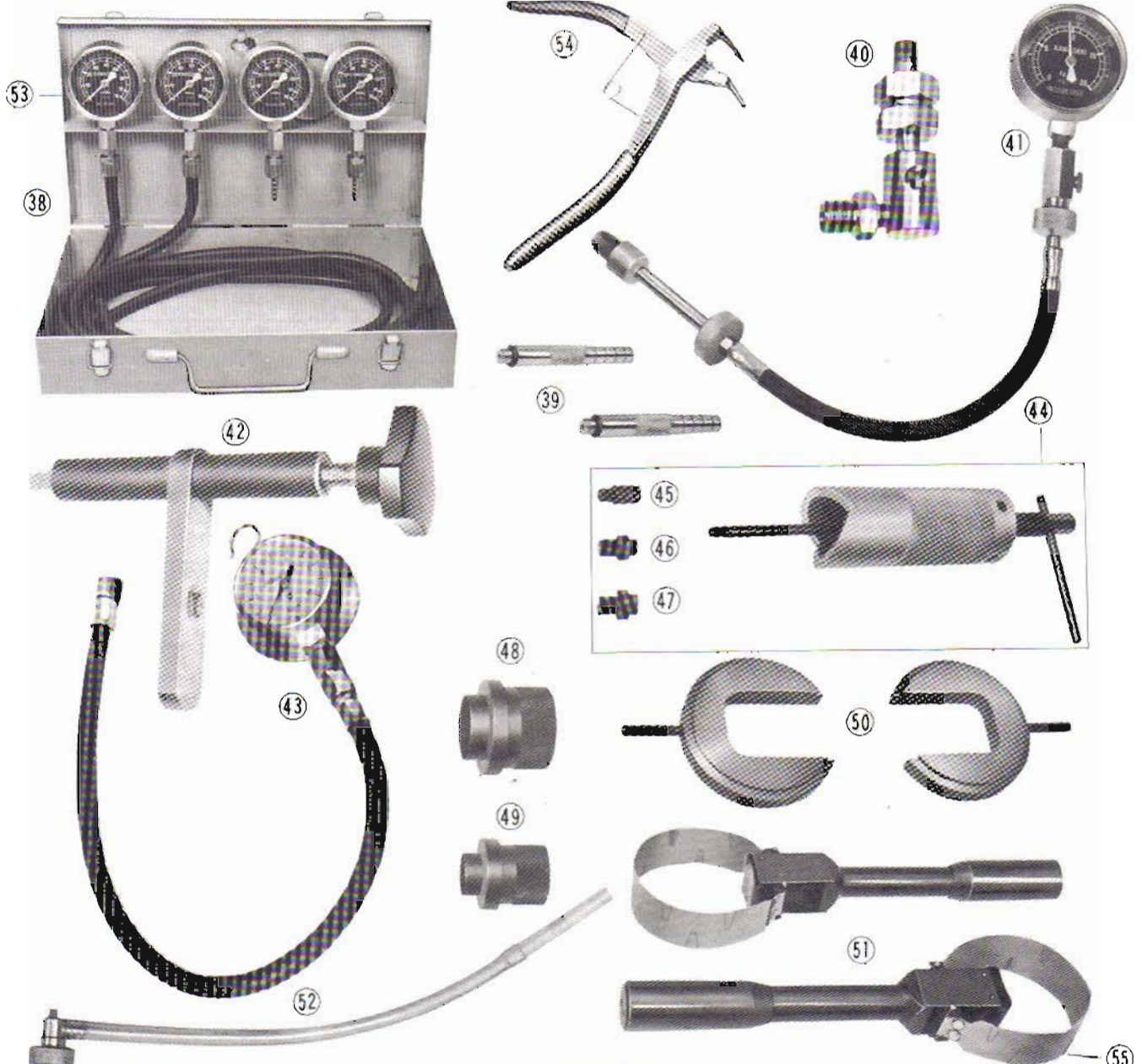

REF.NO.	TOOL NO.	DESCRIPTION
38	57001-127	VACUUM GAUGE
39	57001-401	VACUUM GAUGE ADAPTER
40	57001-400	OIL PRESSURE GAUGE ADAPTER
41	57001-123	COMPRESSION GAUGE
42	57001-350	VALVE CLEARANCE ADJUSTER
43	57001-164	OIL PRESSURE GAUGE
44	57001-910	PISTON PIN PULLER ASSEMBLY
45	57001-912	PISTON PIN PULLER ADAPTER "A"
46	57001-913	PISTON PIN PULLER ADAPTER "B"
47	57001-914	PISTON PIN PULLER ADAPTER "C"
48	57001-265	KICK SHAFT OIL SEAL GUIDE
49	57001-264	SHIFT SHAFT OIL SEAL GUIDE
50	57001-340	PISTON BASE
51	57001-921	PISTON RING COMPRESSOR ASSEMBLY
52	57001-208	FUEL LEVEL GAUGE
53	57001-226	VACUUM GAUGE
54	57001-154	RETAINING RING PLIERS
55	57001-924	PISTON COMPRESSOR ADAPTER "A"

## 172 APPENDIX

## PERIODIC MAINTENANCE

Operation \ Frequency	After initial 800 km	After initial 3,000 km	Every subsequent 3,000 km	Every subsequent 6,000 km	See Page
Change engine oil	•	•	•		173
Replace oil filter element	•	•		•	126
Adjust brakes	•	•	•		17
Adjust drive chain	•	•	•		19
Check, adjust clutch	•	•	•		11, 117
Check, adjust carburetors	•	•	•		9~11
Check spoke tightness and rim runout	•	•	•		131
Tighten nuts and bolts	•	•	•		—
Clean fuel lines	•	•	•		173
Clean, set spark plugs	•	•	•		12, 160
Adjust camshaft chain	•	•	•		15
Check steering play	•			•	16
Check valve clearance	•			•	14
Adjust points, check timing	•	•	•		12
Clean air cleaner element		•	•		96
Carry out general lubrication		•	•		173
Check tire wear		•	•		128
Check drive chain wear		•	•		132
Lubricate drive chain	Every 800 km				133
Check brake wear	Every 6,000 km				138~140
Check front fork oil level	Every 6,000 km				143
Change air cleaner element	Every 10,000 km				96
Change front fork oil	Every 10,000 km				144
Change brake fluid	Every year or 10,000 km				137
Regrease wheel bearings	Every 2 years or 20,000 km				132
Regrease speedometer gear housing	Every 2 years or 20,000 km				132
Regrease brake camshaft	Every 2 years or 20,000 km				141
Lubricate steering stem bearings	Every 2 years or 20,000 km				141

## Engine Oil Change

The engine oil and oil filter are changed as follows:

- Warm up the engine thoroughly, and then stop the engine.
- Set the motorcycle up on its center stand, place an oil pan beneath the engine, and remove the engine drain plug and oil filter.
- Wipe off the drain plug removing any steel filings which may be clinging to it (the drain plug is magnetic).
- After the oil has completely drained out, screw the drain plug back in. Proper torque for the drain plug is 2.0~2.5 kg-m (14.5~18 ft-lbs).
- Replace the oil filter for a new one if necessary, and check that it is properly assembled (Pg. 27).
- Install the oil filter tightening its bolt with 1.5~2.0 kg-m (11~14.5 ft-lbs) of torque.
- Pour in 3 l of SE or SD class SAE 10W40, 10W50, or 20W50 motor oil.

**NOTE:** After the engine has been run and then stopped for a few minutes, the oil level should come to between the upper and lower marks.

## Fuel Line Cleaning

Water or dirt anywhere in the fuel system can cause starting difficulty, poor running, and lack of power. Clean out the lines as follows:

- Turn the fuel tap to STOP. Unscrew the sediment cup at the bottom of the tap, and clean out the water and dirt from it. Clean any dirt out of the fuel tap strainer.

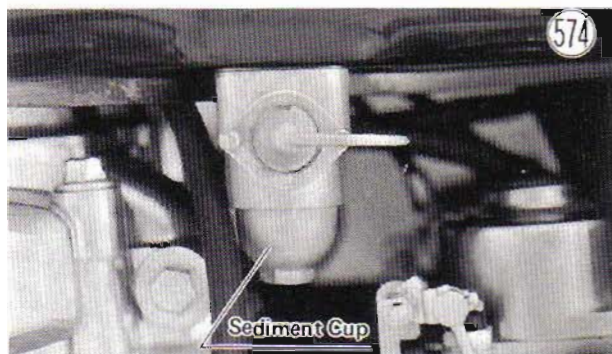

- If there was water inside the sediment cup, there may also be some in the fuel tank. Holding a container under the fuel tap, turn the tap to RES to drain the tank until gasoline only comes out, and then close the tap.
- Remove the plug from the side of each carburetor float bowl to drain the bowls.

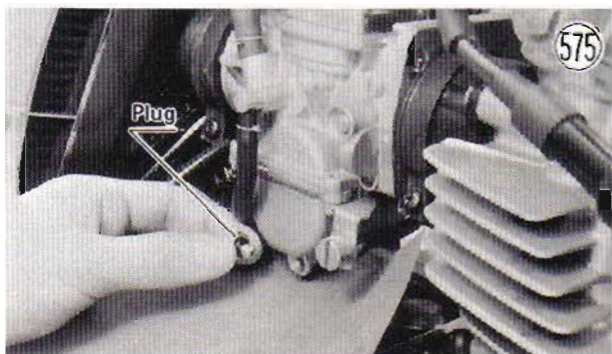

- Replace the plugs and the sediment cup. Make sure

that the O ring is in the tap and that the strainer is not damaged during installation.

## General Lubrication

Lubrication of exposed parts subject to rust with either SAE 30 motor oil or regular grease should be carried out periodically and whenever the vehicle has been operated under wet or rainy conditions. Before lubricating each part, clean off any rusty spots with rust remover. Badly rusted nuts, bolts, etc. should be replaced for new ones.

- Lubricate the clutch cable and the throttle cables as shown in the figure.

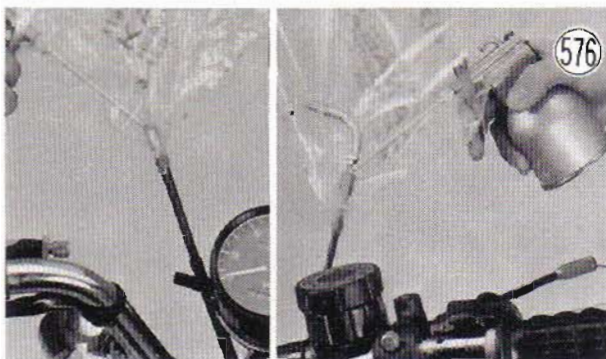

- Lubricate the clutch lever pivot and the exposed portion of the clutch inner cable.
- Wipe off excess lubricant.

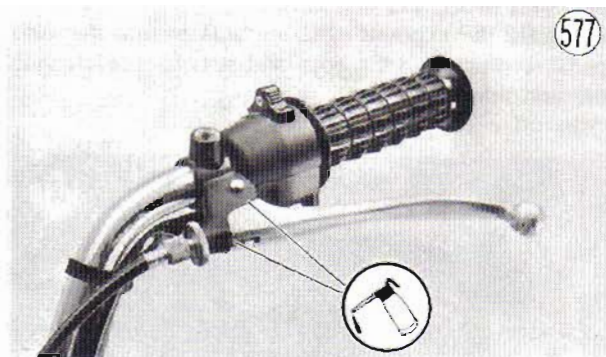

- Lubricate the brake lever pivot.
- Wipe off excess lubricant.

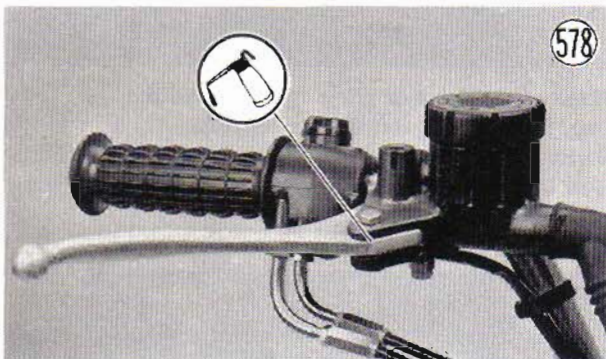

- Wipe clean the throttle grip inner surface and the handlebar where the throttle grip fits.
- Apply grease to the handlebar where the throttle grip turns.
- Apply a light coat of grease to the exposed portion of the throttle grip inner cables and their catches in the throttle grip.
- Fit the throttle cables into the throttle grip.



- Force grease into the fitting until it comes out at both sides of the swing arm, and wipe off any excess.

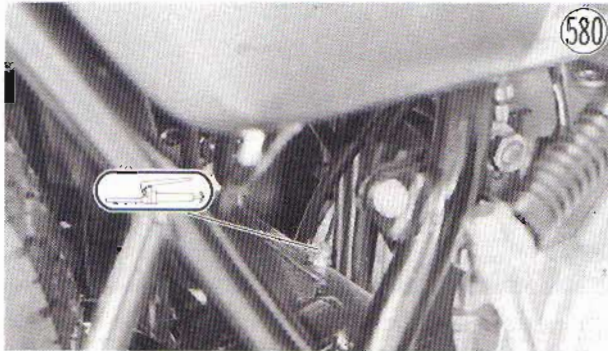

- Wipe off any dirt or grime from around the left foot peg, shift pedal, and side stand.
- Lubricate the exposed metal surfaces around the shift pedal serration and the bolts and nuts for the left foot peg and side stand.
- Wipe off excess lubricant.

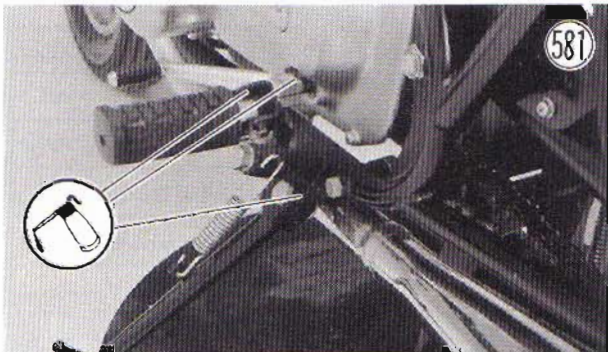

- Wipe off any dirt or grime from around the right foot peg, brake pedal, and kickstarter pedal.
- Lubricate the exposed metal surfaces around the bolts and nuts for the right foot peg, brake pedal, and kickstarter pedal.
- Wipe off excess lubricant.

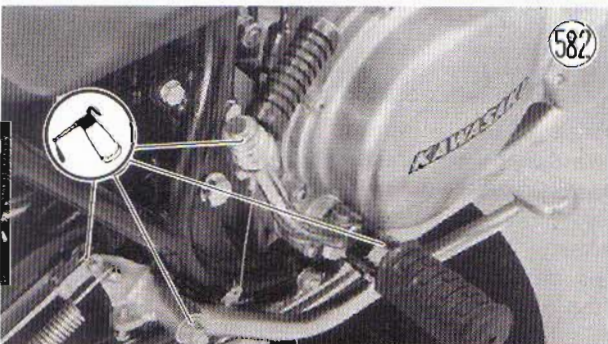

- Oil lightly the end of each drive chain adjuster, the camshaft serration, and the end of the brake rod.
- Wipe off excess oil.

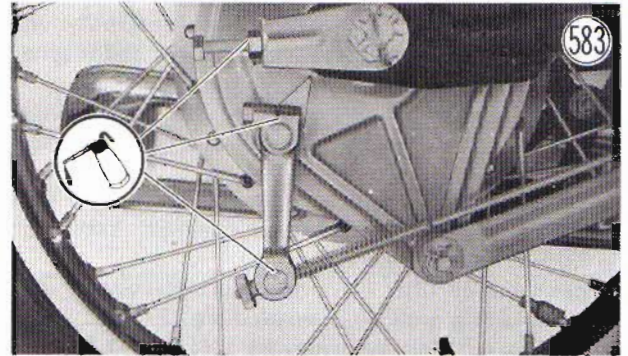

- Lubricate the center stand pivot.

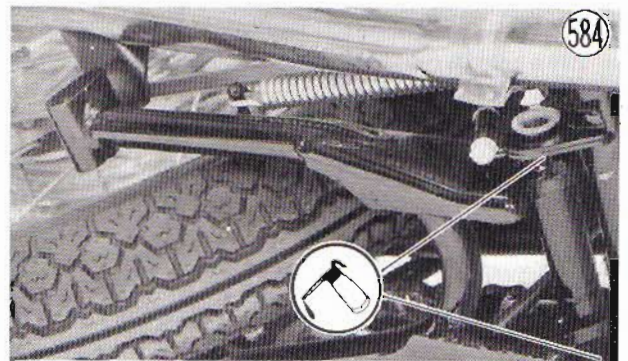

- Oil lightly the carburetor link mechanism and the choke link mechanism.

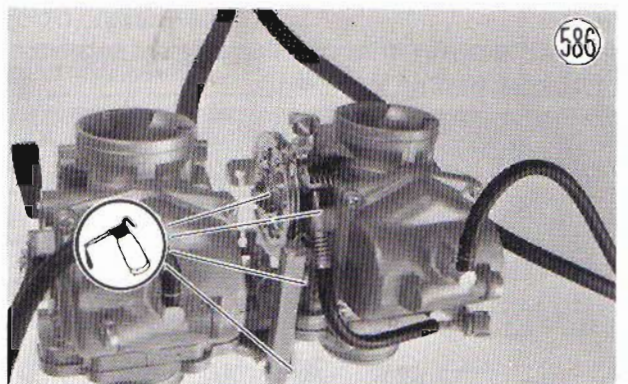
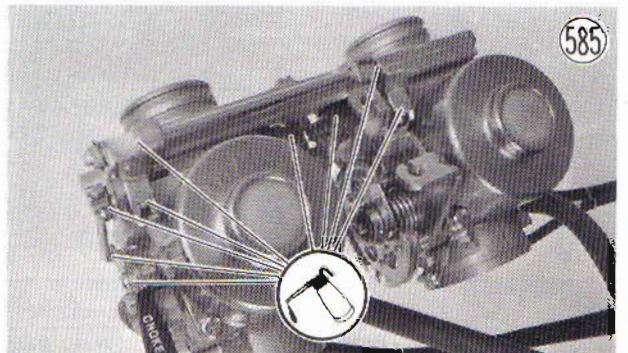

## TORQUE TABLE

Tighten all bolts and nuts to the proper torque using an accurate torque wrench. A bolt or nut if insufficiently tightened may become damaged or fall out, possibly resulting in damage to the motor-cycle and injury to the rider. A bolt or nut which is over-tightened may become damaged, strip an internal screw, or break and then fall out.

The following table lists the tightening torque for the major bolts and nuts:

	Metric	English	See Pg.
Engine drain plug	2.0~2.5 kg-m	14.5~18 ft-lbs	26, 50
Oil filter bolt	1.5~2.0 kg-m	11~14.5 ft-lbs	26, 27, 50
Engine mounting bolts (3)	3.5~4.3 kg-m	<b>25</b> ~31 ft-lbs	24
Engine mounting bracket bolts, front (3)	2.2~2.6 kg-m	16~19 ft-lbs	24
Engine mounting bracket bolts, rear (2)	1.6~2.0 kg-m	11.5~14.5 ft-lbs	—
Breather cover bolts 8 <sup>φ</sup> (4)	1.8~2.0 kg-m	13~14.5 ft-lbs	25, 31,
Cylinder head cover nuts 8 <sup>φ</sup> (8)	2.5~3.0 kg-m	18~22 ft-lbs	31, 69
Cylinder head bolts 8 <sup>φ</sup> (2)	2.5~3.0 kg-m	18~22 ft-lbs	37, 69
Cylinder head bolts 6 <sup>φ</sup> (2)	1.1~1.3 kg-m	95~113 in-lbs	37, 69
Camshaft sprocket bolts 6 <sup>φ</sup> (2)	1.4~1.6 kg-m	10~11.5 ft-lbs	33, 69
Rocker shaft nuts (4)	2.5~3.0 kg-m	18~22 ft-lbs	15
Dynamo rotor bolt 10 <sup>φ</sup>	6.5~7.0 kg-m	47~51 ft-lbs	44, 59
Starter clutch Allen bolts 8 <sup>φ</sup> (3)	3.3~3.7 kg-m	24~27 ft-lbs	45
Dynamo field coil Allen bolts 6 <sup>φ</sup> (3)	0.7~0.8 kg-m	61~69 in-lbs	42
Dynamo armature Allen bolts 6 <sup>φ</sup> (3)	0.7~0.8 kg-m	61~69 in-lbs	42, 43
Engine sprocket nut	12~15 kg-m	87~108 ft-lbs	52, 62
Crankcase bolts 8 <sup>φ</sup> (4)	2.5~3.0 kg-m	18~22 ft-lbs	58
Crankcase bolts 6 <sup>φ</sup> (16)	0.8~1.0 kg-m	69~87 in-lbs	58
Balancer holder bolts 6 <sup>φ</sup> (8)	1.1~1.3 kg-m	95~113 in-lbs	65
* Balancer weight bolts 6 <sup>φ</sup> (2)	1.4~1.6 kg-m	10~11.5 in-lbs	65
Crankshaft bearing cap bolts 8 <sup>φ</sup> (4)	2.5~3.0 kg-m	18~22 ft-lbs	65
Con-rod nuts 8 <sup>φ</sup> (4)	3.3~3.7 kg-m	24~27 ft-lbs	70
Timing advancer bolt	2.3~2.7 kg-m	16.5~19.5 ft-lbs	48, 59
Neutral indicator switch	1.5~2.0 kg-m	11~14.5 ft-lbs	53
Oil pressure indicator switch	1.3~1.5 kg-m	95~130 in-lbs	125
Front axle clamp nuts (2)	1.8~2.0 kg-m	13~14.5 ft-lbs	71
Front axle nut	10~13 kg-m	72~94 ft-lbs	71
Front fork top bolts (2)	2.5~3.0 kg-m	18~22 ft-lbs	88
Shock absorber upper clamp bolts (2)	1.6~1.8 kg-m	12~13 ft-lbs	88, 91
Shock absorber lower clamp bolts (2)	2.0~3.0 kg-m	14.5~ <b>22</b> ft-lbs	16, 91
Stem head clamp bolt	<b>1.6</b> ~1.8 kg-m	12~13 ft-lbs	16, 91
Stem head bolt	<b>5.5</b> kg-m	40 ft-lbs	16, 91
Handlebar clamp bolts (4)	1.1~1.5 kg-m	95~130 in-lbs	84
Rear axle nut	13~16 kg-m	94~116 ft-lbs	20, 73
Torque link nuts (2)	2.7~3.0 kg-m	19.5~22 ft-lbs	20, 73, 93
Rear sprocket nuts (4)	3.5~4.3 kg-m	25~31 ft-lbs	82
Rear shock absorber bolts (2)	2.7~3.3 kg-m	19.5~24 ft-lbs	93, 95
Rear shock absorber cap nuts (2)	2.7~3.3 kg-m	19.5~24 ft-lbs	95
Swing arm pivot shaft nut	10~13 kg-m	72~94 ft-lbs	93
Steering stem lock nut	2.7~3.0 kg-m	19.5~22 ft-lbs	91
Disc brake parts	—	—	77

## 176 APPENDIX

The table below, relating tightening torque to thread diameter and pitch, lists the basic torque for the bolts and nuts used on Kawasaki Motorcycles. However, the actual torque that is necessary may vary among bolts and nuts with the same thread diameter and pitch. The bolts and nuts listed on Pg. 175 vary to a greater or lesser extent from what is given in this table. Refer to this table for only the bolts and nuts not included in the table on Pg. 175. All of these values are for use with dry solvent cleaned threads.

### Coarse threads

dia (mm)	pitch (mm)	kg-m	ft-lbs
5	0.90	0.35 ~ 0.48	2.5 ~ 3.5
6	1.00	0.63 ~ 0.88	4.5 ~ 6.5
8	1.25	1.6 ~ 2.2	11.5 ~ 16.0
10	1.50	3.1 ~ 4.2	22 ~ 30
12	1.75	5.4 ~ 7.5	39 ~ 54
14	2.00	8.3 ~ 11.5	60 ~ 83
16	2.00	13 ~ 18	94 ~ 130
18	2.50	18 ~ 25	130 ~ 181
20	2.50	26 ~ 35	188 ~ 253

### Fine threads

dia (mm)	pitch (mm)	kg-m	ft-lbs
5	0.50	0.35 ~ 0.48	2.5 ~ 3.5
6	0.75	0.55 ~ 0.77	4.0 ~ 5.5
8	1.00	1.4 ~ 1.9	10 ~ 13
10	1.25	2.6 ~ 3.5	18.5 ~ 25
12	1.50	4.5 ~ 6.2	33 ~ 45
14	1.50	7.4 ~ 10.2	54 ~ 74
16	1.50	11.5 ~ 16	83 ~ 116
18	1.50	17 ~ 23	123 ~ 166
20	1.50	23 ~ 33	166 ~ 239

## PARTS REQUIRING USE OF A NON-PERMANENT LOCKING AGENT

Part	Q'ty	See Pg.
Camschaft Sprocket Bolts	2	33, 36, 69
Carburetor Mounting Screws	4	29
Clutch Release Mounting Screws	2	51
Dynamo Rotor Bolt	1	44,59
Dynamo Field Coil Allen Bolts	3	42
Dynamo Armature Allen Bolts	3	42, 43
Starter Motor Retaining Bolts	2	46, 59
Starter Motor Chain Guide Screws	2	42, 43
Starter Motor Clutch Allen Bolts	3	45
Balancer Chain Guide Screws	2	65
Drive Chain Guide Screws	4	51
Primary Chain Guide Screws	2	119
Balancer Weight Bolts	2	65
Neutral Indicator Switch	1	53
Oil Pressure Relief Valve	1	63
External Shift Mechanism Stopper Screws	2	53, 58
External Shift Mechanism Return Spring Pin	1	121
Sump Plate Screws	4	57
Front Fork Bottom Allen Bolts	2	90
Oil Pressure Switch	1	125
Pad B Mounting Screw	1	77
Front Brake Light Switch	1	166

## RECOMMENDED LOCKING AGENTS

1. KAWASAKI LIQUID LOCK-K
2. NON-PERMANENT LOCTITE

## TROUBLESHOOTING GUIDE

**Engine Doesn't Start; Starting Difficulty****Starter motor not rotating**

- Starter motor defective
- Battery voltage low
- Relay not contacting or operating
- Starter button not contacting
- Wiring open or shorted
- Ignition switch defective
- Engine stop switch defective
- Fuse blown

**Starter motor rotating but engine doesn't start**

- Starter motor clutch defective

**Engine won't turn over**

- Valve seizure
- Cylinder, piston seizure
- Con-rod small end seizure
- Con-rod big end seizure
- Transmission gear or bearing seizure
- Camshaft seizure
- Kickstarter return spring broken
- Kick ratchet gear not engaging

**No fuel flow**

- No fuel in tank
- Fuel tap turned off
- Tank cap air vent obstructed
- Fuel tap clogged
- Fuel line clogged
- Float valve clogged
- Starter jet clogged

**Engine flooded**

- Float level too high
- Float valve worn or stuck open
- Starting technique faulty  
(When flooded, kick with the throttle fully open to allow more air to reach the engine.)

**No spark; spark weak**

- Battery voltage low
- Spark plug dirty, defective, or maladjusted
- Spark plug cap or high tension wiring defective
- Spark plug cap shorted or not in good contact
- Contact breaker points dirty or damaged
- Condenser defective
- Ignition coil defective
- Ignition or engine stop switch shorted
- Wiring shorted or open

**Compression low**

- Cylinder, piston worn
- Piston rings bad (worn, weak, broken, or sticking)
- Piston ring clearance excessive
- Cylinder head gasket damaged
- Cylinder head not sufficiently tightened down
- Cylinder head warped
- Spark plug loose
- Valve sticking
- Valve not closing
- Valve spring broken or weak
- Valve not seating properly (valve bent, warped, or worn)

**Poor Running at Low Speed****Spark weak**

- Spark plug dirty, defective, or maladjusted

- Spark plug cap or high tension wiring defective
- Spark plug cap shorted or not in good contact
- Contact breaker points dirty or damaged
- Condenser defective
- Ignition coil defective

**Fuel/air mixture incorrect**

- Pilot screw(s) and/or throttle stop screw maladjusted
- Pilot jet, slow jet, or air passage clogged
- Air cleaner clogged, poorly sealed, or missing
- Starter plunger stuck open
- Carburetor linkage not right
- Float level too high or too low
- Fuel tank air vent obstructed
- Carburetor intake ducts loose

**Compression low**

- Cylinder, piston worn
- Piston rings bad (worn, weak, broken or sticking)
- Piston ring clearance excessive
- Cylinder head gasket damaged
- Cylinder head not sufficiently tightened down
- Cylinder head warped
- Spark plug loose
- Valve sticking
- Valve not closing
- Valve spring broken or weak
- Valve not seating properly (valve bent, warped, or worn)

**Other**

- Ignition timing maladjusted
- Timing not advancing (spring broken or stretched)
- Engine oil viscosity too high

**Poor Running or No Power at High Speed****Firing incorrect**

- Spark plug dirty, defective, or maladjusted
- Spark plug cap or high tension wiring defective
- Spark plug cap shorted or not in good contact
- Contact breaker points dirty or damaged
- Condenser defective
- Ignition coil defective
- Ignition timing maladjusted
- Contact breaker spring weak

**Fuel/air mixture incorrect**

- Main jet clogged or wrong size
- Jet needle or needle jet worn
- Float level too high or too low
- Needle jet bleed hole clogged
- Air cleaner clogged, poorly sealed, or missing
- Starter plunger stuck open
- Water or foreign matter in fuel
- Carburetor intake ducts loose
- Fuel tank air vent obstructed

**Compression low**

- Cylinder, piston worn
- Piston rings bad (worn, weak, broken, or sticking)
- Piston ring clearance excessive
- Cylinder head gasket damaged
- Cylinder head not sufficiently tightened down
- Cylinder head warped
- Spark plug loose
- Valve sticking
- Valve not closing

Valve spring broken or weak  
Valve not seating properly (valve bent, warped, or worn)

**Knocking**

Ignition timing maladjusted  
Carbon built up in combustion chamber  
Fuel poor quality or incorrect

**Miscellaneous**

Throttle valve won't fully open  
Ignition timing maladjusted  
Timing not advancing  
Balancer mechanism malfunctioning  
Brakes dragging  
Clutch slipping  
Overheating  
Engine oil level too high  
Engine oil viscosity too high

**Overheating****Firing incorrect**

Spark plug dirty, damaged, or maladjusted  
Ignition timing maladjusted

**Fuel/air mixture incorrect**

Main jet clogged  
Float level too low  
Carburetor intake ducts loose  
Air cleaner clogged

**Compression high**

Carbon built up in combustion chamber

**Engine load faulty**

Clutch slipping  
Engine oil level too high  
Brakes dragging

**Lubrication inadequate**

Engine oil level too low

**Clutch Operation Faulty****Clutch slipping**

No clutch lever play  
Friction plates worn or warped  
Steel plates worn or warped  
Clutch springs weak  
Clutch cable maladjusted  
Clutch inner cable catching  
Clutch release mechanism defective  
Clutch hub or housing unevenly worn

**Clutch not disengaging properly**

Clutch lever play excessive  
Clutch plates warped or too rough  
Clutch spring tension uneven  
Engine oil deteriorated  
Engine oil of too high a viscosity  
Clutch housing frozen on drive shaft  
Clutch release mechanism defective

**Gear Shifting Faulty****Doesn't go into gear; shift pedal doesn't return**

Clutch not disengaging  
Shift fork(s) bent or seized  
Shift return spring weak or broken  
External shift mechanism pawl broken  
Shift return spring pin loose

External shift mechanism arm spring broken

**Jumps out of gear**

Shift fork(s) worn  
Gear groove(s) worn  
Gear dogs, dog holes, and/or dog recesses worn  
Shift drum groove(s) worn  
Shift drum positioning pin spring weak or broken  
Shift fork pin(s) worn  
External shift mechanism arm spring or pawl worn  
Drive shaft, output shaft, and/or gear splines worn

**Overshifts**

Shift return spring pin loose

**Abnormal Engine Noise****Knocking**

Ignition timing maladjusted  
Carbon built up in combustion chamber  
Fuel poor quality or incorrect  
Overheating

**Piston slap**

Cylinder/piston clearance excessive  
Cylinder, piston worn  
Con-rod bent  
Piston pin, piston holes worn

**Valve noise**

Valve clearance incorrect  
Valve spring broken or weak  
Camshaft bearings worn

**Other noise**

Con-rod small end clearance excessive  
Con-rod big end clearance excessive  
Piston ring(s) worn, broken, or stuck  
Piston seizure damage  
Cylinder head gasket leaking  
Exhaust pipe leaking at cylinder head connection  
Crankshaft runout excessive  
Engine mounts loose  
Crankshaft bearings worn  
Primary chain, chain guides worn  
Starter motor chain, chain guides worn  
Balancer chain, chain guides worn  
Camshaft chain tensioner defective  
Camshaft chain, sprocket, guides worn  
Camshaft chain requires adjustment  
Balancer mechanism springs weak or broken

**Abnormal Drive Train Noise****Clutch noise**

Clutch housing/friction plate clearance excessive

**Transmission noise**

Bearings worn  
Transmission gears worn or chipped  
Metal chips jammed in gear teeth  
Engine oil insufficient or too thin  
Kick ratchet gear not properly disengaging from kick gear

**Drive chain noise**

Chain worn  
Rear and/or engine sprocket(s) worn  
Chain lubrication insufficient  
Rear wheel misaligned

**Abnormal Frame Noise****Front fork shock absorber noise**

- Oil insufficient or too thin
- Spring weak or broken

**Rear shock absorber noise**

- Shock absorber defective

**Front brake noise**

- Pad B loose
- Pad surface glazed
- Disc warped
- Caliper seal defective
- Cylinder damaged

**Rear brake noise**

- Brake linings overworn or worn unevenly
- Drum worn unevenly or scored
- Brake spring weak or broken
- Foreign matter in hub
- Brake not properly adjusted

**Other noise**

- Brackets, nuts, bolts, etc. not properly mounted or tightened

**Oil Pressure Indicator Light Goes On**

- Engine oil pump defective
- Engine oil screen clogged
- Engine oil level too low
- Camshaft journals worn
- Crankshaft bearings worn
- Oil pressure indicator light switch defective
- Wiring defective

**Exhaust Smoke****White smoke**

- Piston oil ring worn
- Cylinder worn
- Valve guide worn
- Engine oil level too high

**Black smoke**

- Air cleaner clogged
- Main jet too large or fallen off
- Starter plunger stuck open
- Float level too high

**Brown smoke**

- Main jet too small
- Float level too low
- Carburetor intake ducts loose

**Handling and/or Stability Unsatisfactory****Handlebar hard to turn**

- Steering stem lock nut too tight
- Bearing balls damaged
- Race(s) dented or worn
- Steering stem lubrication inadequate
- Steering stem bent
- Tire air pressure too low

**Handlebar shakes or excessively vibrates**

- Tire(s) worn
- Swing arm bushing damaged
- Rim(s) warped, or not balanced
- Front, rear axle runout excessive
- Spokes loose
- Wheel bearing(s) worn
- Handlebar clamps loose

**Handlebar pulls to one side**

- Frame bent
- Wheel misalignment
- Swing arm bent or twisted
- Swing arm pivot shaft runout excessive
- Steering stem bent
- Front fork shock absorber(s) bent
- Right/left front fork shock absorber oil level uneven
- Right/left rear shock absorbers unbalanced

**Shock absorption unsatisfactory**

- Too hard:
  - Front fork oil excessive
  - Front fork oil viscosity too high
  - Tire air pressure too high
  - Rear suspension maladjusted
- Too soft:
  - Front fork oil insufficient and/or leaking
  - Front fork oil viscosity too low
  - Front fork, rear shock absorber spring(s) weak
  - Rear shock absorber oil leaking

**Brakes Don't Hold****Front wheel**

- Air in the brake line
- Pad or disc worn
- Brake fluid leak
- Brake fluid deteriorated
- Primary or secondary cup defective
- Master cylinder scratched inside

**Rear wheel**

- Brake maladjusted
- Brake lining or drum worn
- Overheated
- Water on brake drum
- Brake cam, camshaft worn
- Oil on brake linings

**Battery Discharged**

- Battery faulty (e.g., plates sulphated, shorted through sedimentation, electrolyte level too low)
- Battery leads making poor contact
- Rectifier defective
- Ignition switch defective
- Regulator defective
- Armature coil open or short
- Wiring faulty

**Battery Overcharged**

- Regulator defective or wiring open
- Dynamo defective
- Battery defective

**NOTE:** This is not an exhaustive list, giving every possible cause for each problem listed. It is meant simply as a rough guide to assist the troubleshooting for some of the more common difficulties. Electrical troubleshooting is not covered here due to its complexity. For electrical problems, refer to the appropriate heading in the Maintenance Section.

# KZ400 Wiring Diagram (US Model)

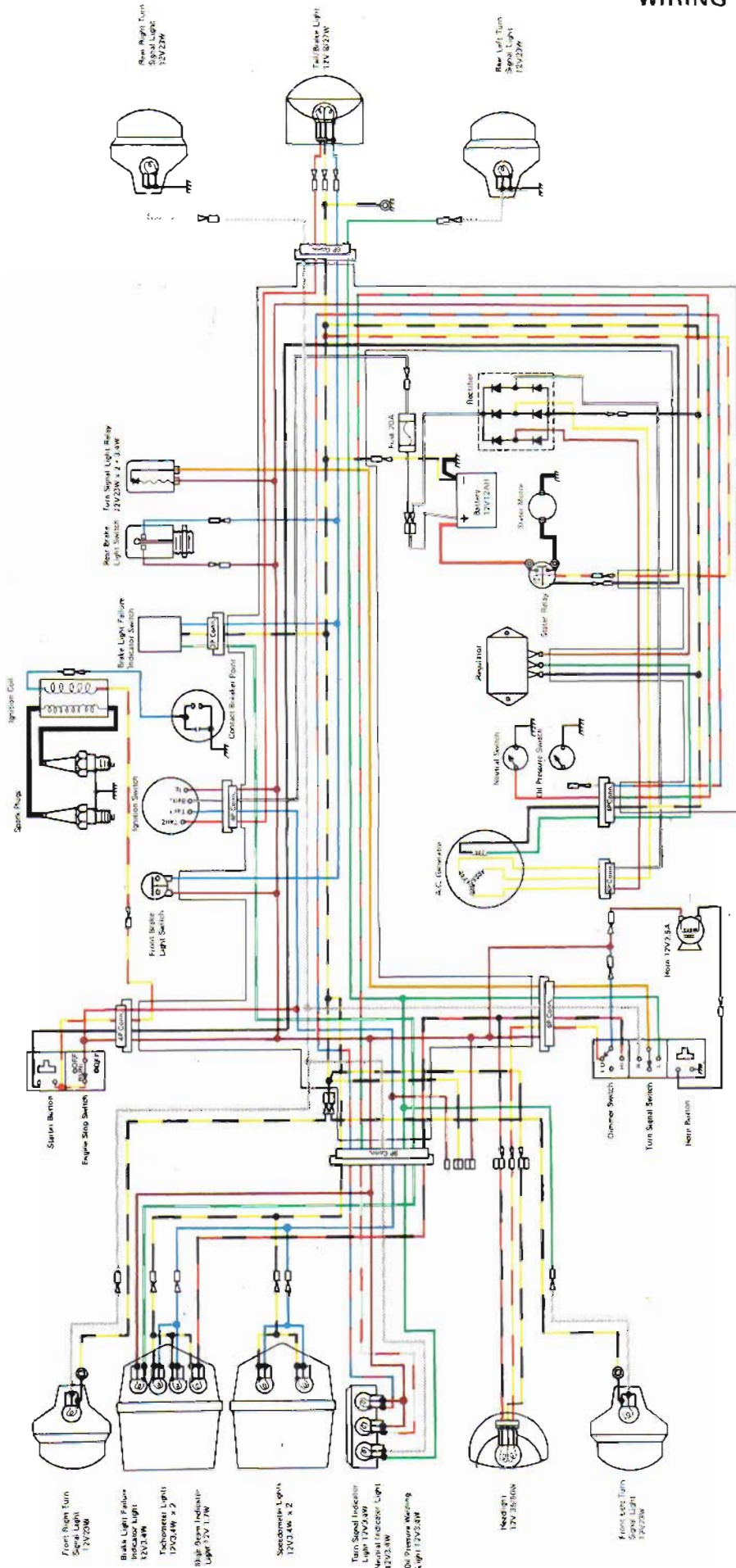

Right Hand Side Switch Connections

Starter Button	Ignition Stop Switch
OFF	OFF
IGN	IGN
Comp	Comp
12V	12V
Blk	Blk
Grn	Grn
Red	Red
Wh	Wh

Left Hand Side Switch Connections

Turn Signal Switch	Turn Signal Switch
L	L
R	R
Blk	Blk
Grn	Grn
Red	Red
Wh	Wh

Front Panel Switch Connections

Turn Signal Switch	Turn Signal Switch
L	L
R	R
Blk	Blk
Grn	Grn
Red	Red
Wh	Wh



# Index

- Air cleaner ..... 96  
 Air cleaner element ..... 26, 96  
 Axle, front ..... 71, 131  
 Axle, rear ..... 73, 131  
  
 Balancer chain ..... 64~66, 115  
 Balancer mechanism ..... 64~66, 113~115  
 Battery ..... 154~157  
 Brake, front ..... 17, 134~139  
 Brake, rear ..... 17~19, 139~141  
 Brake fluid ..... 136~138  
 Brake light circuit ..... 165~167  
 Brake light failure indicator ..... 166~167  
 Brake light switch, front ..... 19, 165  
 Brake light switch, rear ..... 19, 165  
 Brake lining ..... 73~75, 140  
 Brake lining wear indicator ..... 18, 75  
  
 Cable, clutch ..... 84~85  
 Cable, speedometer ..... 86  
 Cable, tachometer ..... 86  
 Cables, throttle ..... 9, 85~86  
 Chain, balancer ..... 64~66, 115  
 Chain, camshaft ..... 15~16, 66~70, 103~104  
 Chain, drive ..... 19~20, 81~82, 132~133  
 Chain, primary ..... 48~50, 78~119  
 Chain, starter motor ..... 45, 163~164  
 Chain guide, balancer ..... 64~66, 115  
 Chain guide, camshaft ..... 70~71, 103~104  
 Chain guide, primary ..... 48~50, 118~119  
 Caliper ..... 77~78, 138  
 Camshaft ..... 32~34, 102~103  
 Camshaft chain ..... 15~16, 66~70, 103~104  
 Camshaft chain guide, front ..... 70, 103~104  
 Camshaft chain guide, rear ..... 70~71, 103~104  
 Carburetors ..... 9~11, 27~29, 96~102  
 Clutch ..... 11~12, 48~50, 115~118  
 Clutch cable ..... 84~85  
 Clutch release ..... 50~51  
 Condenser ..... 47, 158  
 Con-rods ..... 70, 111~113  
 Contact breaker ..... 47, 157~158  
 Coupling ..... 82~83, 132  
 Crankshaft ..... 66~70, 111~113  
 Cylinder block ..... 39~40, 108~111  
 Cylinder head ..... 34~37, 104~108  
  
 Disc ..... 77, 139  
 Disc brake ..... 76~81, 134~139  
 Drive chain ..... 19~20, 81~82, 132~133  
 Drive shaft ..... 61  
 Dynamo ..... 147~150  
 Dynamo armature ..... 43, 147~150  
 Dynamo field coil ..... 41~42, 147~150  
 Dynamo rotor ..... 44~45  
  
 Engine ..... 22~26  
 Engine lubrication ..... 123~127  
 Engine oil change ..... 173  
 Engine oil pump ..... 53, 126  
 External shift mechanism ..... 53~55, 121  
  
 Front brake lever ..... 17  
 Front fork ..... 87~90, 142~145  
 Front hub ..... 71~72  
 Front wheel ..... 71~72  
 Fuel line cleaning ..... 173  
 Fuel tank ..... 27, 127~128  
 Fuel tap ..... 127~128  
  
 General lubrication ..... 173~174  
 Grease seals ..... 131~132  
  
 Handlebar ..... 83~84  
 Headlight ..... 20~21, 87, 164~165  
 Headlight circuit ..... 164~165  
 Headlight unit ..... 87  
 Horn ..... 21, 168  
 Horn circuit ..... 168  
  
 Ignition coil ..... 47, 158~159  
 Ignition switch ..... 87, 164  
 Ignition system ..... 157~159  
 Ignition timing ..... 12~14  
 Indicator lights ..... 87, 168  
 Introduction to disassembly ..... 22  
  
 Kickstarter ..... 62~63, 122~123  
  
 Lubrication, engine ..... 123~127  
 Lubrication, general ..... 173~174  
  
 Master cylinder ..... 78~81, 138  
 Mufflers ..... 27, 147  
  
 Neutral indicator switch ..... 52~53  
  
 Oil breather ..... 127  
 Oil filter ..... 26~27, 126~127  
 Oil pressure indicator switch ..... 125  
 Oil pressure relief valve ..... 63~64  
 Oil pump ..... 53, 126  
 Output shaft, transmission ..... 61~62  
  
 Pad ..... 77, 138  
 Performance curves ..... 7~8  
 Periodic maintenance ..... 172~174  
 Pistons ..... 40~41, 108~111  
 Piston rings ..... 40~41, 111  
 Point gap ..... 12, 14  
 Points requiring use of a non-permanent  
     locking agent ..... 177  
 Primary chain ..... 48~50, 118~119  
  
 Rear brake ..... 17~19, 73~75, 139~141  
 Rear shock absorbers ..... 20, 95, 145

## 184 INDEX

- Rear hub ..... 75
- Rear wheel ..... 72~75
- Rectifier ..... 150~151
- Regulator ..... 151~154
- Relief valve ..... 63~64
- Rim ..... 76, 128~131
- Rocker arms ..... 29~31, 104
- Rocker shafts ..... 29~31, 104
  
- Shaft, balancer ..... 65, 114~115
- Shaft, camshaft ..... 32~34, 102~103
- Shaft, crankshaft ..... 66~70, 111~113
- Shaft, drive ..... 61
- Shaft, output ..... 61~62
- Shaft, rocker arm ..... 29~31, 104
- Shift drum ..... 59~61, 121~122
- Spark plugs ..... 12, 159~160
- Special tools ..... 169~171
- Specification ..... 5~6
- Speedometer ..... 86, 168
- Speedometer cable ..... 86
- Speedometer gear housing ..... 71, 132
- Spokes ..... 128~131
- Sprocket, camshaft ..... 104
- Sprocket, engine ..... 51~52
- Sprocket, primary ..... 48~50
- Sprocket, rear ..... 82~83
- Sprocket, starter motor ..... 45
- Sprockets ..... 133~134
- Starter motor ..... 45~47, 160~163
- Starter motor circuit ..... 160~163
- Starter motor chain ..... 45, 163~164
- Starter motor clutch ..... 44~45, 163~164
- Starter plunger unit ..... 29
- Starter relay ..... 163
- Steering ..... 16~17
- Steering stem ..... 90~92, 141~142
- Steering stem bearing ..... 92~93
- Swing arm ..... 93~95, 146~147
  
- Tachometer ..... 86, 168
- Tachometer cable ..... 86
- Throttle cables ..... 9, 85~86
- Timing advancer ..... 47~48, 159
- Tires ..... 75~76, 128
- Torque table ..... 175~176
- Transmission ..... 55~62, 119~122
- Troubleshooting guide ..... 178~180
- Tube, tire ..... 75~86
- Turn signal relay ..... 167~168
- Turn signals ..... 167~168
  
- Valve clearance ..... 14~15
- Valve guide ..... 37~39, 105
- Valves ..... 37~39, 104~108
- Valve seat ..... 105
  
- Wheel balance ..... 17
- Wheel bearings ..... 131~132
- Wheel, front ..... 71~72
- Wheel, rear ..... 72~75
- Wheels ..... 128~132
- Wiring diagram ..... 181

**KAWASAKI**  
HEAVY INDUSTRIES, LTD.  
ENGINE & MOTORCYCLE GROUP

Part No. 99997-710

Printed in Japan